

Böhringer, Christoph; Löschel, Andreas

Working Paper

Measuring Sustainable Development: The Use of Computable General Equilibrium Models

ZEW Discussion Papers, No. 04-14

Provided in Cooperation with:

ZEW - Leibniz Centre for European Economic Research

Suggested Citation: Böhringer, Christoph; Löschel, Andreas (2004) : Measuring Sustainable Development: The Use of Computable General Equilibrium Models, ZEW Discussion Papers, No. 04-14, Zentrum für Europäische Wirtschaftsforschung (ZEW), Mannheim

This Version is available at:

<https://hdl.handle.net/10419/24066>

Standard-Nutzungsbedingungen:

Die Dokumente auf EconStor dürfen zu eigenen wissenschaftlichen Zwecken und zum Privatgebrauch gespeichert und kopiert werden.

Sie dürfen die Dokumente nicht für öffentliche oder kommerzielle Zwecke vervielfältigen, öffentlich ausstellen, öffentlich zugänglich machen, vertreiben oder anderweitig nutzen.

Sofern die Verfasser die Dokumente unter Open-Content-Lizenzen (insbesondere CC-Lizenzen) zur Verfügung gestellt haben sollten, gelten abweichend von diesen Nutzungsbedingungen die in der dort genannten Lizenz gewährten Nutzungsrechte.

Terms of use:

Documents in EconStor may be saved and copied for your personal and scholarly purposes.

You are not to copy documents for public or commercial purposes, to exhibit the documents publicly, to make them publicly available on the internet, or to distribute or otherwise use the documents in public.

If the documents have been made available under an Open Content Licence (especially Creative Commons Licences), you may exercise further usage rights as specified in the indicated licence.

Discussion Paper No. 04-14

**Measuring Sustainable Development:
The Use of
Computable General Equilibrium Models**

Christoph Böhringer and Andreas Löschel

ZEW

Zentrum für Europäische
Wirtschaftsforschung GmbH

Centre for European
Economic Research

Discussion Paper No. 04-14

**Measuring Sustainable Development:
The Use of
Computable General Equilibrium Models**

Christoph Böhringer and Andreas Löschel

Download this ZEW Discussion Paper from our ftp server:

<ftp://ftp.zew.de/pub/zew-docs/dp/dp0414.pdf>

Die Discussion Papers dienen einer möglichst schnellen Verbreitung von neueren Forschungsarbeiten des ZEW. Die Beiträge liegen in alleiniger Verantwortung der Autoren und stellen nicht notwendigerweise die Meinung des ZEW dar.

Discussion Papers are intended to make results of ZEW research promptly available to other economists in order to encourage discussion and suggestions for revisions. The authors are solely responsible for the contents which do not necessarily represent the opinion of the ZEW.

Nontechnical Summary

In 1987, the report of the World Commission on Environment and Development (Brundtland Commission) defined *Sustainable Development* (SD) as “development, which meets the needs of the present without compromising the ability of future generations to meet their own needs”. *Sustainable Development* has meanwhile become one of the most prominent catchwords on the world’s policy agenda. Nearly all governments and multinational firms have committed themselves to the overall concept of *Sustainable Development*. Taking a lead role, the European Union (EU) requires *Sustainability Impact Assessment* (SIA) in terms of a “careful assessment of the full effects of [any larger] policy proposal ... [that] ... must include estimates of its economic, environmental and societal inputs inside and outside the EU” (EC, 2001).

Yet, *Sustainable Development*, which is not just about environment, but also about economy and society, has proven hard to define and rather susceptible for ambiguities. Furthermore, the three dimensions of *Sustainable Development*, i.e. environmental quality, economic performance (gross efficiency) and equity concerns are inherently intertwined and subject to trade-offs. Accomplishing one objective frequently means backpedaling on another. The quantification of trade-offs calls for the use of numerical model techniques in order to assess systematically and rigorously the interference of the many forces that interact in the economy thereby affecting potential *Sustainable Development* indicators.

In general, there is no specific model, which fits all requirements for comprehensive *Sustainability Impact Assessment*, but rather a package of models (or methods) depending on the policy measure or issue to be assessed and the availability of data. However, when it comes to providing a flexible backbone tool for *Sustainability Impact Assessment*, the current paper tries to make a good case for the use of computable general equilibrium (CGE) models. We argue that computable general equilibrium models can incorporate several key sustainability indicators in a single micro-consistent framework, thereby allowing for a systematic quantitative trade-off analysis between environmental quality, economic performance and income distribution. Furthermore, the computable general equilibrium approach provides an open framework for linkages to sector-specific models, important relationships to other disciplines adopting an integrated assessment approach or the incorporation of new economic research strings. This flexibility makes computable general equilibrium models a central tool for *Sustainability Impact Assessment*.

Measuring Sustainable Development: The Use of Computable General Equilibrium Models

Christoph Böhringer and Andreas Löschel
Centre for European Economic Research (ZEW), Mannheim
P.O. Box 10 34 43, D-68034 Mannheim, Germany

Abstract: This paper advocates computable general equilibrium models as a methodological tool that is particularly suitable for measuring the impacts of policy interference on the three dimensions of *sustainable development*, i.e. environmental quality, economic performance (gross efficiency) and equity. These dimensions are inherently intertwined and subject to trade-offs. Computable general equilibrium models can incorporate various important *sustainable development* indicators in a single consistent framework and allow for a systematic quantitative trade-off analysis.

JEL classification: D58

Keywords: computable general equilibrium modeling (CGE), sustainability impact assessment (SIA), sustainable development (SD)

Acknowledgements: Financial support by the European Commission (DG Research) under the projects *Methodologies for Integrating Impact Assessment in the Field of Sustainable Development* (MinimaSud), *Transition to Sustainable Economic Structures* (TranSust) and *Indicators and Quantitative Tools for Improving the Process of Sustainability Impact Assessment* (I.Q. TOOLS) is gratefully acknowledged. Regarding any remaining inadequacies, the usual caveat applies.

1 INTRODUCTION

In 1987, the report of the World Commission on Environment and Development (WCED or Brundtland Commission) defined *Sustainable Development* (hereafter: *SD*) as “development, which meets the needs of the present without compromising the ability of future generations to meet their own needs” (WCED, 1987). In June 1992, the Rio Earth Summit concluded that “the right to development must be fulfilled so as to equitably meet developmental and environmental needs of present and future generations” (UNCED, 1992a, Principle 3). *SD* has meanwhile become one of the most prominent catchwords on the world’s policy agenda. Nearly all governments and multinational firms have committed themselves to the overall concept of *SD*.

The ubiquity of *SD* as a yardstick for human activities is reflected in the growing importance of *Sustainability Impact Assessment* (hereafter: *SIA*) of governmental policies. Initially, the assessment of *SD* impacts concentrated on trade policy reforms (see, e.g., Kirkpatrick and Lee, 1999, for the *SIA* of WTO’s Millennium Round proposal). More recently, *SIA* has been extended to other policy areas. Taking a lead role, the European Union (EU) meanwhile requires “careful assessment of the full effects of [any larger] policy proposal ... [that] ... must include estimates of its economic, environmental and societal inputs inside and outside the EU” (EC, 2001). The argument behind is that *SIA* can improve the *SD* coherence of policy initiatives across various areas by identifying spillovers and inter-linkages.

However, *SD*, which is not just about environment, but also about economy and society, has proven hard to define and rather susceptible for ambiguities. One reason for this is that *SD* explicitly incorporates an (normative) equity dimension, which is “*so hopelessly subjective that it cannot be analyzed scientifically*” (Young, 1994). Another reason is that the scope of the concept seems prohibitively comprehensive and therefore complex to make it operational in concrete practice.

Acknowledging the huge inherent difficulties to come up with pragmatic approaches to the concept of *SD* and the need for *SIA*, the scientific community has focused in a first step on the identification of appropriate indicators. These efforts included the development of qualitative tools (e.g. electronic checklists such as IA^{STAR}, see <http://iaplus.jrc.es>) that can provide useful orientation for policy decision makers. Yet, qualitative approaches are unable to commensurate different impacts. This constitutes a major shortcoming, since the three dimensions of *SD*, i.e. environmental quality, economic performance (gross efficiency) and equity concerns are inherently intertwined and subject to trade-offs. Accomplishing one objective frequently means backpedaling on another. Therefore, research activities on *SIA* increasingly aim at developing

quantitative tools for trade-off-analysis along the *SD* dimensions. Since economics is the study of trade-offs, there is plenty for economists to contribute in order to make the concept of *SD* operational. One important contribution of (environmental) economics over the last decade has been the thorough assessment of external costs, in particular for energy transformation and transport activities, as a prerequisite towards “getting the prices right” (see, e.g., EC, 1999; Friedrich and Bickel, 2001). Given external cost estimates, two aspects of *SD*, namely economic performance (gross efficiency) and environmental quality, can be merged to a comprehensive net efficiency dimension. Furthermore, while economics has little to say on equity *per se*, the sound economic quantification of distributional effects for different agents and trade-offs between equity and efficiency objectives is a prerequisite for any rational policy debate.

The quantification of trade-offs calls for the use of numerical model techniques in order to assess systematically and rigorously the interference of the many forces that interact in the economy thereby affecting potential *SD* indicators. Compared to (stylized) analytical models, the numerical approach facilitates the analysis of complex (non-linear) system interactions and the impact assessment of structural policy changes. In the end, the decisions how to resolve potential trade-offs must be taken on the basis of societal values and political decisions. However, model-based analysis puts decision making on an informed basis concerning sustainable development rather than on fuzzy or contradictory hunches.

A major challenge in building quantitative *SIA* tools is the policy makers’ demand for comprehensive coverage of potentially important policy impacts. *SIA* tools must identify “the chain of significant cause-effect links from the ... [policy] measures ... through to any sustainability impact” and produce “comparable indicators of the magnitude and dimensions of each sustainability impact” (EC, 2003a) as an input into policy formulation and implementation. Obviously, quantitative *SIA* does not only require an adequate reduction of complex real-world relationships but – as a pre-requisite – the translation of potentially vague policy proposals into a concrete policy impetus that can be “processed” within an analytical model.

There is a wide range of quantitative models for assessing the causal chains between a proposed policy change and its potential economic, environmental and social impacts. Models mainly differ with respect to the emphasis placed on (i) sectoral details versus economy-wide scope, (ii) econometric foundation of functional relationships, and (iii) the richness of behavioral assumptions for economic agents. Referring to criterion (i), there is a widespread distinction between bottom-up sector-level models and top-down macroeconomic models. Referring to criterion (ii), models can be classified as either econometrically estimated when driving equations are based on econometric techniques using mostly time-series data or as calibrated

when parameters of functional forms are simply selected to fit a single empirical observation. Referring to criterion (iii), models may be distinguished between micro-/macro-founded approaches and simple accounting frameworks.

While such a taxonomy of models can be useful, it has its limits. For example, the common dichotomy between top-down economy-wide models and bottom-up sectoral models is in general not of theoretical nature (i.e. due to controversial theoretical underpinnings) but simply relate to the level of aggregation and the scope of *ceteris paribus* assumptions. In fact, there have been various model developments merging bottom-up approaches and top-down models within one consistent framework (see, e.g., Böhringer, 1998). Furthermore, among top-down models there is often an exaggerated divide between econometric demand-driven Keynesian models and computable general equilibrium (CGE) models. Popular arguments against the informational value of CGE models include that these models must be calibrated (and thus lack empirical evidence) and can neither reflect disequilibria (such as unemployment or under-utilization of production capacities) nor transitional dynamics. In turn, econometric Keynesian models are often accused of a lack of micro-foundation. These claims ignore substantial developments during the last two decades to overcome such policy-relevant shortcomings.

In general, there is no specific model, which fits all requirements for comprehensive *SIA*, but rather a package of models (or methods) depending on the policy measure or issue to be assessed and the availability of data. However, when it comes to providing a flexible backbone tool for *SIA*, the current paper tries to make a good case for the use of CGE models (see also Böhringer, forthcoming). We argue that CGE models can incorporate several key sustainability (meta-) indicators in a single micro-consistent framework, thereby allowing for a systematic quantitative trade-off analysis between environmental quality, economic performance and income distribution. Furthermore, the CGE approach provides an open framework for linkages to sector-specific models, important relationships to other disciplines adopting an integrated assessment approach or the incorporation of new economic research strings. This flexibility makes CGE models a central tool for *SIA*.

The structure of the paper is as follows. Section 2 addresses the definition of *SD* indicators as a prerequisite for *SIA*. We focus on two highly policy-relevant indicator lists (UN, 2001; EC, 2003b), distinguishing between (i) indicators that are covered by our stylized core CGE model (as laid out in section 3), (ii) indicators that are in the scope of more or less straightforward extensions of our core CGE model, and (iii) indicators that are rather difficult to address in quantitative (CGE) analysis. Section 3 provides a non-technical introduction into a standard multi-sector, multi-region CGE model of global trade and energy use that we consider as a

possible backbone for (more) comprehensive quantitative *SIA*. Section 4 illustrates some selected extensions of this core modeling framework that allow for appropriate treatment of potentially important impacts triggered by specific policy proposals. Section 5 outlines possible model linkages. Section 6 concludes.

Two major caveats apply: First, we do not cover competing or complementary quantitative modeling approaches to *SIA*, i.e. we do not provide a cross-comparison of model-specific strengths and weaknesses. Second, our exclusive focus on quantitative (CGE-based) analysis should not exaggerate the role numerical approaches can play in *SIA*. Policy decisions are the outcome of a broader participatory process where stakeholders and other interested parties communicate a wide range of values, perceptions and judgements to policy makers (Tamborra, 2002). Quantitative analysis – if available at all – can at best strengthen or weaken policy arguments, putting decision making on a more informed basis.

2 INDICATORS FOR SUSTAINABLE DEVELOPMENT

Monitoring progress towards *SD* requires in the first place the identification of operational indicators that provide manageable units of information on economic, environmental and social (including institutional) conditions. The crucial role of *SD* indicators has been prominently emphasized by the *United Nations Conference on Environment and Development* (UNCED), held in Rio de Janeiro in 1992, that calls on individual countries as well as international governmental and non-governmental organizations to “develop and identify indicators of sustainable development in order to improve the information basis for decision-making at all levels” (UNCED, 1992b, Agenda 21, Chapter 40). Since then, much work has been devoted on indicators for measuring *SD*. The *Compendium of Sustainable Development Indicator Initiatives* lists more than 500 sustainable indicator efforts (Parris and Kates, 2003). Here, we focus on two policy-relevant systems of sustainable indicators that have been developed by the *United Nations Commission on Sustainable Development* (CSD – section 2.1) and the *European Commission* (EC – section 2.2) for use by countries on a national level. Reflecting the purpose of the paper, the exposition of the indicator systems below (Tables 1 and 2) includes our subjective and preliminary assessment which individual indicators may be captured within a CGE modeling framework.

2.1 United Nations Commission on Sustainable Development (CSD)

The United Nations *Commission on Sustainable Development* (CSD), established in 1992 to ensure effective follow-up of the UNCED, focused its work to date mainly on the development and testing of indicators that could be readily used in planning, policy formulation, and evaluation at the national level. The initial work program on *Indicators of Sustainable Development* resulted in a list of 134 indicators, which covers social, environmental, economic, and institutional aspects of *SD*. After voluntary national testing (within 22 countries) and expert group consultation, a reduced and revised set of 58 “core indicators” categorized within 15 themes and 38 sub-themes (see Table 1) for monitoring the progress towards *SD* was released (UN, 2001).

2.2 European Commission (EC)

Efforts by the European Community to integrate environmental objectives into the different fields of policy-making date back to the early 1970s as manifested e.g. within the first Environmental Action Plan (EAP, 1973). The Amsterdam Treaty, signed in 1997, codified environmental policy integration as a central EU policy element within Article 6: “... environmental protection requirements must be integrated into the definition and implementation of the Community policies ... in particular with a view to promoting sustainable development” and furthermore re-enforced Article 2, which defines *SD* as a fundamental objective for the European Community.

Table 1: CSD theme indicator framework (UN, 2001)

Theme	Sub-theme	Indicator	CORE	EXTENDED
Economic				
Economic Structure	Economic Performance	1. GDP per Capita	X	
		2. Investment Share in GDP		X
	Trade	3. Balance of Trade in Goods and Services	X	
	Financial Status	4. Debt to GNP Ratio		X
		5. Total ODA Given or Received as a Percent of GNP		X
Consumption and Production Patterns	Material Consumption	6. Intensity of Material Use	X	
	Energy Use	7. Annual Energy Consumption per Capita	X	
		8. Share of Consumption of Renewable Energy Resources		X
		9. Intensity of Energy Use		X
		10. Generation of Industrial and Municipal Solid Waste		X
	Waste Generation and Management	11. Generation of Hazardous Waste		X
		12. Management of Radioactive Waste		
		13. Waste Recycling and Reuse		X
	Transportation	14. Distance Traveled per Capita by Mode of Transport		X
	Environmental			
Atmosphere	Climate Change	15. Emissions of Greenhouse Gases	X	
	Ozone Layer Depletion	16. Consumption of Ozone Depleting Substances		X
	Air Quality	17. Ambient Concentration of Air Pollutants in Urban Areas		X
Land	Agriculture	18. Arable and Permanent Crop Land Area		X
		19. Use of Fertilizers		X
		20. Use of Agricultural Pesticides		X
	Forests	21. Forest Area as a Percent of Land Area		X
		22. Wood Harvesting Intensity		X
	Desertification	23. Land Affected by Desertification		X
	Urbanization	24. Area of Urban Formal and Informal Settlements		
Oceans, Seas and Coasts	Coastal Zone	25. Algae Concentration in Coastal Waters		
		26. Percent of Total Population Living in Coastal Areas		
	Fisheries	27. Annual Catch by Major Species		
Fresh Water	Water Quantity	28. Ann. Withdrawal of Ground & Surface Water as % of Total Avail.		X
	Water Quality	29. BOD in Water Bodies		X
		30. Concentration of Faecal Coliform in Freshwater		
Biodiversity	Ecosystem	31. Area of Selected Key Ecosystems		
		32. Protected Area as a % of Total Area		
	Species	33. Abundance of Selected Key Species		
Social				
Equity	Poverty	34. Percent of Population Living below Poverty Line		X
		35. Gini Index of Income Inequality		X
		36. Unemployment Rate		X
	Gender Equality	37. Ratio of Average Female Wage to Male Wage		X
Health	Nutritional Status	38. Nutritional Status of Children		
	Mortality	39. Mortality Rate Under 5 Years Old		
		40. Life Expectancy at Birth		
	Sanitation	41. Percent of Population with Adequate Sewage Disposal Facilities		
	Drinking Water	42. Population with Access to Safe Drinking Water		
	Healthcare Delivery	43. Perc. of Population with Access to Primary Health Care Facilities		
		44. Immunization Against Infectious Childhood Diseases		
		45. Contraceptive Prevalence Rate		
Education	Education Level	46. Children Reaching Grade 5 of Primary Education		
		47. Adult Secondary Education Achievement Level		
	Literacy	48. Adult Literacy Rate		
Housing	Living Conditions	49. Floor Area per Person		
Security	Crime	50. Number of Recorded Crimes per 100,000		
Population	Population Change	51. Population Growth Rate		
		52. Population of Urban Formal and Informal Settlements		
Institutional				
Institutional Framework	Strategic Impl. of SD	53. National Sustainable Development Strategy		
	International Cooperation	54. Implementation of Ratified Global Agreements		
Institutional Capacity	Information Access	55. Number of Internet Subscribers per 1000 Inhabitants		
	Comm. Infrastructure	56. Main Telephone Lines per 1000 Inhabitants		
	Science & Tech.	57. Expenditure on Research and Development as a Percent of GDP		X
	Disaster Prep. & Resp.	58. Economic and Human Loss Due to Natural Disasters		

X Incorporation of the indicator in the core and extended CGE model, respectively.

The Gothenburg Summit in 2001 came up with the definition of an *European Union Strategy for Sustainable Development* that combines the commitment to improved environmental performance (Helsinki European Council 1999) with the objective “to become the most competitive and dynamic knowledge-based economy in the world capable of sustainable economic growth with more and better jobs and greater social cohesion” (Lisbon European Council 2000). An annual stocktaking of the progress towards *SD* – due at each spring summit – was agreed upon. The first progress report was prepared for the Barcelona Summit in 2002, featuring 76 structural indicators. The subsequent report in 2003 then included 107 indicators. Since the large number of indicators made it rather difficult to draw a clear picture on *SD* progress (EC, 2003b) the Spring Report 2004 has been scheduled to report on only 14 structural indicators thereby balancing the importance of employment, innovation and research, economic reform, social cohesion and the environment (see Table 2).

Table 2: EC structural indicators proposed for Spring Report 2004 (EC, 2003b)

EC	Indicator	CSD correspondence	CORE EXTENDED
I.	GDP per capita	(1)	X
II.	Labor productivity		X
III.	Employment rate	(36)	X
IV.	Employment rate of older workers		X
V.	Spending on human resources (public exp. on education)	(46-47)	
VI.	Research and Development expenditure	(57)	X
VII.	Information Technology expenditure	(55-56)	X
VIII.	Financial market integration (conv. of bank lending rates)		X
IX.	At risk-of-poverty rate	(34)	X
X.	Long-term unemployment		X
XI.	Dispersion of regional employment rates		X
XII.	Greenhouse gases emissions	(15)	X
XIII.	Energy intensity of the economy	(7-9)	X
XIV.	Volume of transport	(14)	X

X Incorporation of indicator in the core and extended CGE model, respectively.

3 THE CGE BACK-BONE TO (SUSTAINABLE) IMPACT ANALYSIS

Among numerical methods, computable general equilibrium (CGE) models are widely employed by various national and international organizations (EU Commission, IMF, World Bank, OECD, etc.), research centers, and universities for economic policy analysis at the sector-level as well as the economy-wide level. CGE models build upon general equilibrium theory that combines behavioral assumptions on rational economic agents with the analysis of equilibrium conditions. They provide counterfactual (ex-ante) comparisons, assessing the outcomes with reform in place with what would have happened had it not been undertaken (or undertaken in a different way). The main virtue of the CGE approach is its comprehensive micro-consistent representation of price-dependent market interactions. The simultaneous explanation of the origin and spending of the agents' income makes it possible to address both economy-wide efficiency as well as distributional impacts of policy interference. This has made CGE models a standard tool for the quantitative analysis of policy interference in many domains including fiscal policy, trade policy, and environmental policy. For survey articles see e.g. Bhattacharyya (1996), Bergman (1990), Borges (1986), Conrad (1999, 2001), Klepper et al. (1994) and Shoven and Whalley (1992).

In section 3.1, we lay out the generic structure of a multi-sector, multi-region CGE framework of global trade and energy use. We consider a multi-region framework as indispensable for *SIA* of major policy initiatives in a world that is increasingly integrated through trade. Policy interference in open economies not only cause adjustment of domestic production and consumption patterns but also influence international prices via changes in exports and imports. The changes in international prices, i.e. the terms of trade, imply a *secondary* benefit or burden, which can significantly alter the impacts of the *primary* domestic policy. Likewise, countries, which do not undertake policy reforms will nevertheless be affected through international spillovers. In addition to the consistent representation of trade links, the detailed representation of energy flows captures a major segment of the environmental *SD* dimension, i.e. energy usage and air quality. Combustion of fossil fuels is a driving force of global warming through the release of CO₂ and cause serious regional and transboundary pollution through emissions/imissions of SO_x and NO_x. The comprehensive scope of multi-region, multi-sector CGE models explains why such models play a dominant role in the assessment of trade policy impacts (see e.g. Lee and Kirckpatrick, 2001; Francois and Reinert, 1997) and climate policy analysis (see e.g. Böhringer and Löschel, 2002). In section 3.2, we sketch the central steps involved in applied CGE analysis that readily transfer to *SIA* of policy reforms and address the issue of model parameterization.

3.1 The Core Model

Figure 1 provides a diagrammatic structure of the standard multi-sector multi-region trade model with energy flows as often used for comparative-static impact analysis of trade and environmental or energy policies. Primary factors of a region r include labor \bar{L}_r , capital \bar{K}_r and resources $\bar{Q}_{ff,r}$ of fossil fuels ff (crude oil, coal, and gas). The specific resource used in the production of crude oil, coal and gas results in upward sloping supply schedules. Production Y_{ir} of commodities i in region r , other than primary fossil fuels, is captured by aggregate production functions which characterize technology through substitution possibilities between various inputs. Nested constant elasticity of substitution (CES) cost functions with several levels are employed to specify the KLEM substitution possibilities in domestic production sectors between capital (K), labor (L), energy (E) and non-energy intermediate inputs, i.e. material (M). Depending on data availability, the economy can be disaggregated into as many as several hundred producing sectors (see, e.g., U.S. Department of Commerce, 1993).

Final demand C_{ir} in each region is determined by utility maximization of a representative agent RA_r subject to a budget constraint. Total income of the representative agent consists of his factor income. Final demand is given as a CES composite which combines consumption of an energy aggregate with a non-energy consumption bundle. The substitution patterns within the non-energy consumption bundle as well as the energy aggregate are described by nested CES functions. Emissions are associated with fossil fuel consumption in production, investment, and final demand.

All goods used on the domestic market in intermediate and final demand correspond to a CES composite A_{ir} of the domestically produced variety and a CES import aggregate M_{ir} of the same variety from the other regions, the so-called Armington good (Armington, 1969). Domestic production either enters the formation of the Armington good or is exported to satisfy the import demand of other regions. The balance of payment constraint, which is warranted through flexible exchange rates, incorporates the benchmark trade deficit or surplus for each region.

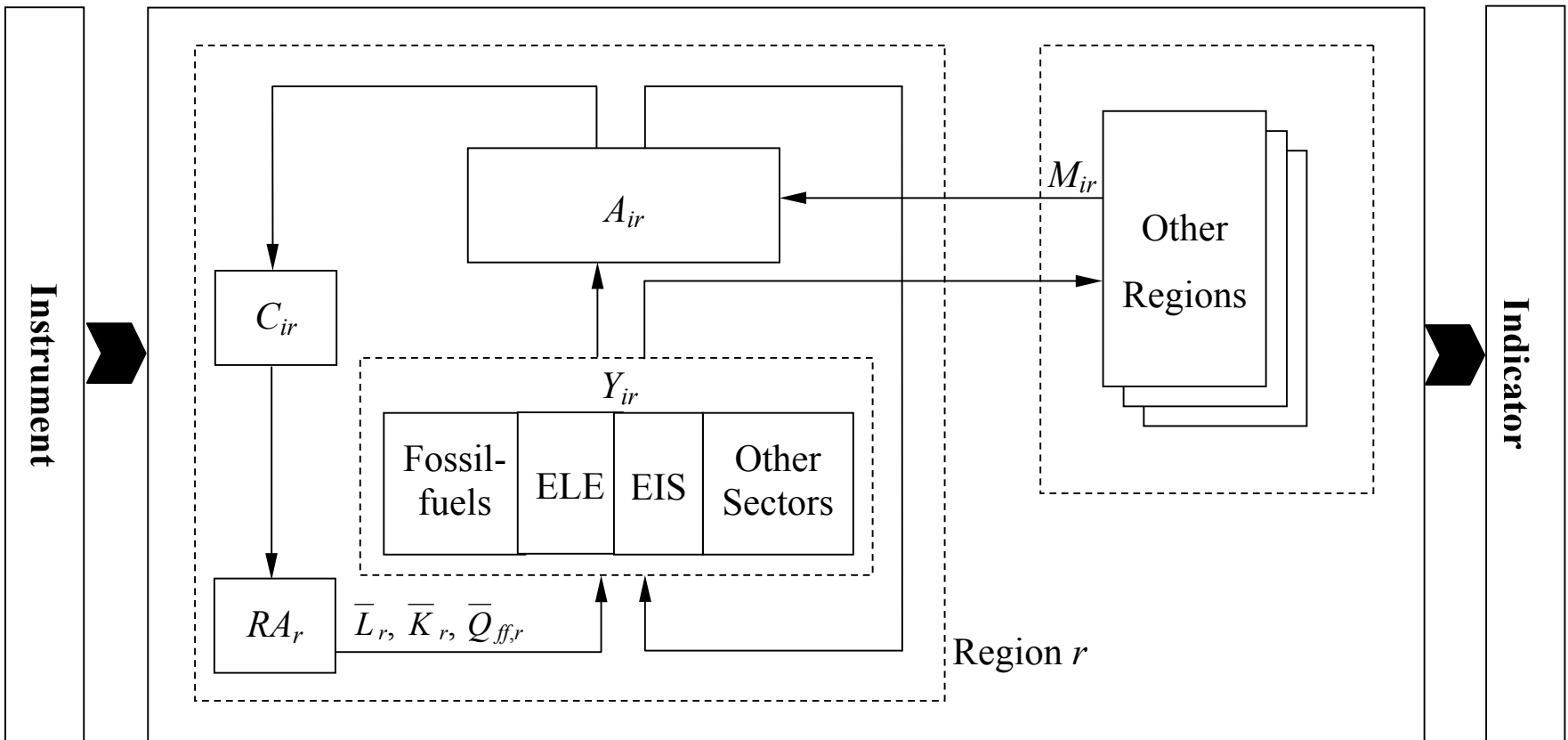

Figure 1: CGE core model for SIA

**Core
CGE
Model**

3.2 Central Steps in CGE-based SIA

The use of quantitative models for measuring *SD* impacts of policy reforms requires the specification of indicators, instruments, and analytical chains. First, measurable sustainability indices covering the *SD* concerns of interest have to be defined and instruments that may promote sustainability in different domains have to be identified. Then, the complete path from the application of the instrument to the impact on the sustainability indicator has to be modeled. Finally, policy explorations have to be carried out and implications on the sustainability indicators have to be assessed.

Our core (generic) CGE model of global trade and energy use can be applied for quantitative trade-off analysis along the three dimension of sustainability since it allows the representation of the entire chain from policy interference to implied changes in major *SD* indicators (predominantly economic and environmental impacts). A wide range of policy measures that are subject to *SIA* is readily available in the core modeling framework such as environmental policies (e.g. emission permits and taxes), fiscal measures (e.g. structural adjustments, tax reforms) or trade policies (e.g. trade liberalization).

Our core CGE model focuses on traditional economic performance indicators (CSD 1, 3, 6, 7, 9; EC I-III, XIII) and environmental impacts in terms of emissions from fossil fuel combustion, most notably CO₂ (CSD 15; EC XII). The analytical chain from instruments to impacts on *SD* indicators can be illustrated for the imposition of carbon taxes. Carbon (or energy) taxes raise marginal costs of production due to abatement expenditure and tax payments, which leads to higher market prices. The higher domestic price attracts imports and lowers exports of energy-intensive goods (CSD 3). Firms substitute labor, material and capital for the taxed energy input for keeping adjustment costs low. Consumers reduce their consumption of energy alike. The reduced energy consumption (CSD 7, 9; EC XIII) and fossil fuel use results in reductions in CO₂ emissions, the main greenhouse gas (CSD 15; EC XII). Labor demand benefits from the positive substitution effect (CSD 36; EC II, III). Material use (CSD 6) also tends to increase. However, there is also a negative output effect due to increased prices and reduced domestic production (CSD 1; EC I) that results from the new distortions in intermediate and final consumption.

The central steps involved in constructing and using CGE models for policy impact analysis are summarized in Figure 2. Initially, the policy issue must be carefully studied to decide on the appropriate model design as well as the required data. The second step involves the use of economic theory (at best, the draft of a simple analytical maquette model) in order

to lay out key economic mechanisms that may drive the results in the more complex numerical model (causal chain). Data work, model formulation and implementation then delivers the framework for numerical policy analysis. This step also involves the set-up of alternative policy instruments and strategies that induce changes vis-à-vis the reference situation (scenario definition). In determining results of policy simulations, the choice and parameterization of functional forms are crucial. The procedure most commonly used to select parameter values is known as calibration (see Mansur and Whalley, 1984). Calibration of the free parameters of functional forms requires a consistent one year's data (or a single observation represented as an average over a number of years), together with exogenous elasticities that are usually taken from literature surveys. Benchmark data is typically delivered in value terms. In order to obtain separate price and quantity observations, the common convenient procedure is to choose units for goods and factors so that they have a price of unity in the benchmark equilibrium. The calibration is a deterministic procedure and does not allow for statistical test of the model specification. The one consistency check that must necessarily hold before one can proceed with policy analysis is the replication of the initial benchmark: the calibrated model must be capable of generating the base-year (benchmark) equilibrium as a model solution without computational work. Within the policy simulations single parameters or exogenous variables are changed and a new (counterfactual) equilibrium is computed. Comparison of the counterfactual and the benchmark equilibrium then provides information on the policy-induced changes of economic variables such as employment, production, consumption, relative prices, etc. Finally, the model results must be interpreted based on sound economic theory. In that, theoretical analysis and numerical work are complementary. As theoretical models must be highly stylized to keep analytical tractability, their direct contribution to actual policy analysis remains limited. Numerical methods are required to account for policy-relevant complexities but must be accompanied by theoretical analysis to detect potential (programming) errors and to reduce the black-box character of quantitative simulations.

The extent to which policy instruments alter sustainable development indicators depends crucially on the responsiveness of supply and demand with respect to price changes (i.e. elasticities). Due to the reliance on exogenous elasticity values and a single base-year observation, comprehensive sensitivity analysis on key elasticities and possibly alternative assumptions on economic incentives should be performed before concrete policy recommendations are derived. A deliberate sensitivity analysis helps to identify robust

insights on the complex relationships between assumptions (inputs) and results (outputs), i.e. sort out the relative importance of a priori uncertainties.

Figure 2: Steps in CGE analysis (Böhringer, 1996)

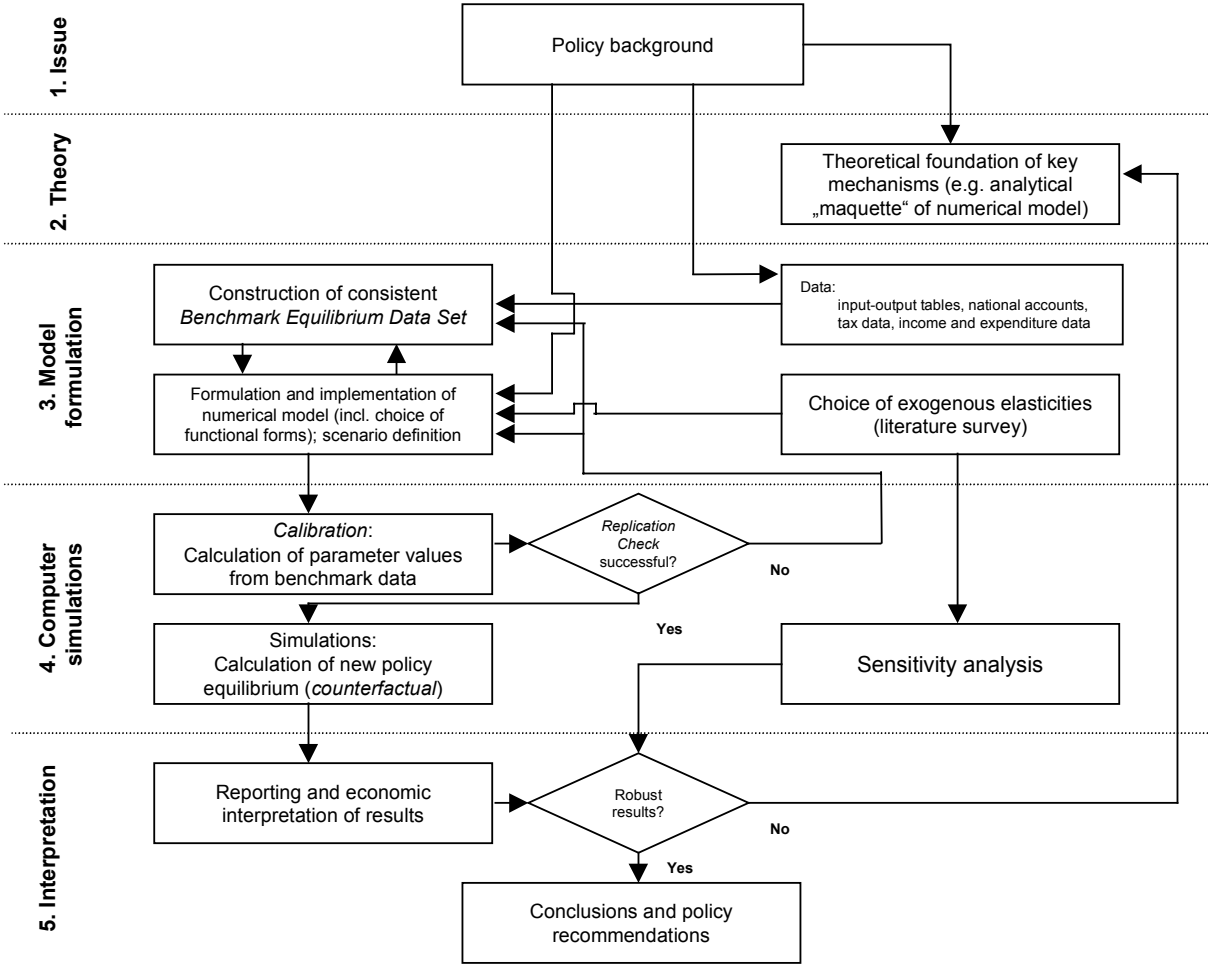

4 CORE MODEL EXTENSIONS

Our core model covers only a few indicators for *SIA* (see column “core” in Tables 1 and 2). In this section, we illustrate some extensions of the core model that widen its scope and policy relevance with respect to *SIA*. There are various other developments of the CGE methodology targeted to specific aspects for *SIA* that are not covered here.

As to environmental impacts, our core model focuses on carbon dioxide from fossil fuel use, since it constitutes the largest contribution to global warming. However, there are potentially important non-CO2 greenhouse gases (GHG) as well as other detrimental emissions that should be included in a broader *SIA*. Real world economies are characterized

by initial market distortions such as taxes (subsidies) and imperfections on goods and factor markets. The existence of market distortions can substantially alter the impacts of policy interference. A further important extension of the core model is the addition of dynamics in order to investigate the adjustment path of economies during the transition towards some *SD* targets in the future. Policy-induced technological change may also have substantial implications for the relative attractiveness of alternative policy initiatives. Finally, our core model considers distributional analysis across regions but lacks a disaggregation of the representative agent into heterogeneous households or different generations.

4.1 Air (CSD 15-17; EC XII)

In our core model carbon emissions are directly linked to fossil fuel inputs in production or consumption. Carbon emission abatement can take place either through reduction of good output or substitution of non-polluting inputs for polluting inputs (fuel switching and fuel savings). However, other GHG emissions, ozone depleting substances or air pollutants cannot be directly linked in fixed proportions to input or output activities in economic sectors.

Approaches to endogenize non-CO₂ pollution control in CGE models include: (i) the creation of clean-up sectors (“end-of-pipe” abatement activities) separately from the technology associated with the production of the good output that use capital, labor and other inputs to provide abatement services which are demanded by emitting sectors as an additional input (Conrad and Schröder, 1991) and (ii) modeling the GHG directly as an input into production. To introduce GHG control, the production function is parameterized in consistence with technological based marginal abatement cost curves of control options (Hyman et al., 2003).

4.2 Initial Taxes and Revenue Recycling

It is well known that the way revenues from environmental regulation (e.g. emission taxes or auctioned tradable permits) are used has major impacts on the social costs of the environmental policies (see, e.g., Goulder, 1995). When revenues are employed to reduce existing tax distortions, environmental regulation presents an opportunity to simultaneously improve environmental quality and offset at least part of the adjustment burden by reducing the costs of the tax system.

In our core model, revenues are recycled lump-sum to the representative agent in each

region and initial tax distortions are not explicitly considered. It is straightforward to incorporate a governmental sector that collects taxes (e.g. production taxes or subsidies, intermediate input taxes, consumption taxes, tariffs, which are used to finance the public good provision and public transfers. Additional income from environmental taxes or emission levies such as carbon taxes on industrial and final fossil fuel use may then be used within a revenue-neutral (equal-yield) tax reform (see e.g. Goulder 1995, Böhringer et al., 1997).

4.3 Imperfect Competition on Factor and Goods Markets

Involuntary unemployment (CSD 36; EC III, IV)

Persistent unemployment at high levels is a central impediment to *SD* in many countries. Thus, a major requirement to new policy initiatives is that unemployment problems will at least not be worsened. A convenient shortcut to replace the competitive labor market in our core model is the specification of a „wage curve“ (Blanchflower and Oswald, 1994). The wage curve reflects empirical evidence on the inverse relationship between the level of wages and the rate of unemployment. In such a model, the wage curve, together with labor demand, determines the level of involuntary unemployment (see, e.g., Böhringer et al., 2003a).

Imperfectly competitive goods markets

The core model is based on perfectly competitive goods markets. However, there is a widespread suspicion that such a setting misses important industrial organization effects of policy interference such as changes in economies of scale or price mark-ups. In order to account for these effects, the core model can be extended to feature imperfectly competitive supply behavior and increasing returns to scale (see Böhringer and Löschel, forthcoming). Relaxing the assumption of perfect competition, allocation effects emerge from increased competition and the exploitation of scale economies (so-called pro-competitive effects): Market enlargement increases competition between firms that enforces lower prices. It can also lead to higher production and the use of economies of scale. Increased competition from the greater substitutability of products within the enlarged market is another source for rationalization gains under imperfect competition.

4.4 Dynamic Specification (CSD 2)

Key issues in *SD* policy involve interference over longer time periods. Examples include

GHG abatement strategies to cope with global warming or direct regulation of energy technologies such as an administered phase-out of nuclear power or a phase-in of renewable energies. A dynamic framework is essential to capture the adjustment path of physical and human capital stocks for such exogenous policy changes. Furthermore, it allows to address issues of resource depletion, stock pollution and economic growth which are central to the *SD* debate. On the consumption side, dynamics involve the representation of the savings behavior of households. On the production side, dynamics involve the description of investment decisions (including resource exploration and extraction strategies) of firms. There are two basic approaches to handle dynamics: (i) the dynamic-recursive framework based on myopic expectations, and (ii) the fully intertemporal setting with perfect foresight.

Adopting a dynamic-recursive approach the static core model is solved for a sequence of temporary equilibria with consumers allocating income between present and future consumption (through savings) at each point in time. Savings is based on the expected return assuming myopic predictions (i. e. the households assume prices to remain constant). On the production side of the economy there are also myopic expectations assumed. Equilibrium ensures the saving-investment equality. The path for the economy is a set of connected equilibria where the current period's saving augments capital in the next period. Capital stocks are updated as an intermediate calculation between periods.

Following the intertemporal approach the static model is casted into an intertemporal setting where consumption and investment decisions are based on rational expectations of future prices (Lau et al., 2002). This assures that the effects of policy interference on savings and investments are consistently taken into account. The intertemporal framework reveals effects of policy changes on intertemporal consumption and investment (savings) decisions, permits measurement of transition costs (inter-sectoral adjustments) and rates of resource depletion as well as long-term growth effects, which can be significant relative to long-term gains.

4.5 Technological Change (CSD 2, 8, 57; EC V-VII)

For the measurement of sustainability, an appropriate incorporation of technological change may be of paramount importance (see EMF, 1996). In our core model (as in most existing CGE models), technological change is considered to be a non-economic, exogenous variable. Economic activities and policies have then no impact on research, development, and diffusion of new technologies. Changes in technologies are solely the result of price substitution along a

given production isoquant (described by price elasticities) and shifts of the isoquant through changes in factor demand. Existing technologies are gradually replaced in CGE models as relative prices of alternative technologies change.

Only more recently, CGE models took into account the empirical evidence that technological change is to an important degree endogenous, i.e. responding to socio-economic (policy) variables like prices, investment in R&D, or cumulative production (see Löschel, 2002 for an overview). As, e.g., environmental policy implicitly or explicitly increases the price of energy, firms invest in R&D with the intention of producing profitable new (energy efficient) products and processes. Goulder and Schneider (1999) construct a dynamic CGE model in which firms in each sector employ physical capital and knowledge capital to produce output. Knowledge accumulation (expenditure on R&D activities) reduces the input requirements for the industries. But the accumulation of knowledge is costly. In addition, the investment in R&D may provide spillovers, or positive technological externalities. In the same manner, spillovers from, e.g., IT expenditures could be modeled.

4.6 Equity (CSD 34-37; EC III, IV, IX-XI)

As mentioned before, the quantification of social aspects in CGE models featuring a single representative household per region is limited. To assess the distributional impacts of policies, a disaggregation of the household sector into several types of households is required. Jorgenson and Wilcoxon (1993) subdivided the household sector into demographic groups that differ by characteristics such as family size, age of head, region of residence, race and urban and rural location and considered 1344 different household types based on these criteria.

From a dynamic perspective the analysis of distribution issues may require an extension towards overlapping generations (OLG) models, where households are heterogeneous by age, i.e. agents are distinguished by date of birth. There are various examples of single-country CGE models with overlapping generations. Keuschnigg and Kohler (1994) use a Blanchard type approach where different generations are alive each period and each generation has the same constant death probability independent of age (perpetual youth approach) to study intergenerational effects of fiscal policy. Rasmussen and Rutherford (forthcoming) employ a multi-sector OLG model of the Auerbach-Kotlikoff type to investigate the impacts of an environmental tax reform at the single country-level. However, an OLG framework with multiple regions, sectors *and* households (generations) still poses considerable computational

challenge and requires severe trade-offs with the level of remaining details that can be captured in the model.

5 FURTHER EXTENSIONS: MODEL LINKAGES

Inherently, the strength of rather aggregate, economy-wide CGE models in capturing sustainability effects of policy initiatives at the level of different regions, sectors and households cause deficiencies when it comes to more narrow specific or small-scale impact assessment. There are many complementary quantitative models that feature substantially more details of technological conditions (e.g. engineering bottom-up energy system models), socio-economic household behaviour (e.g. micro-simulation models) or natural science relationships (e.g. climate models, water stress models, land-use models).

This raises the question to which extent and in which manner different models can be linked towards a more comprehensive coverage of SIA requirements. In principle, there are two basic approaches for model linkages which are loosely termed as soft-link vis-à-vis hard-link (see, e.g., Böhringer 1996). Roughly speaking, the soft-link approach involves combination of two or more models that have been developed independently from another and can be run stand-alone. Due to the heterogeneity in complexity and accounting methods across different models, the soft-link approach stands out for substantial problems in achieving overall consistency and convergence of iterative solution approaches. On the other hand, it allows to maintain detailed information embodied within the various (often interdisciplinary) models without requiring comprehensive central expertise. Furthermore, linkages can be based on established models rather than requiring modeling work from scratch. These rather pragmatic advantages may outweigh to some degree pending deficiencies in overall consistency. The hard-link approach puts strong emphasis on internal consistency and therefore makes use of a single integrated modeling framework (e.g. our core CGE model presented in section 3). Information from other models are directly “coded” into the core model. This means that data and functional relationships from other models must be condensed and synthesized in a way compatible to the structure of the core model.

In modeling practise, most examples of soft-links between top-down CGE models and bottom-up approaches refer to energy-economy model systems (see, e.g., Bergman and Lundgren, 1990). There are various large-scale detailed sectoral models for energy (CSD 7-9; EC XIII) and transport (CSD 14; EC XIV) that may be soft-linked to CGE models to cover a

wider range of sustainability indicators such as PRIMES (EC, 1995) and POLES (EC, 1996), or REMOVE (van Herbruggen, 2002).

Beyond soft-linked energy-economy model systems, integrated assessment models (IAM) seek to combine knowledge from multiple disciplines in an analytic framework to assess the effects of different policy options. The IAM framework typically features broad system linkages and feedbacks, particularly between socio-economic and biophysical processes. For example, within the IMAGE model system (IMAGE-Team, 2001), a CGE sub-model and a population sub-model feed basic information on economic and demographic developments for several world regions into other linked sub-models such as a land-cover model (which calculates global land-use and land-cover changes including changes in agricultural land (CSD 18), forests (CSD 21), and desertification (CSD 23)). Another prominent example is the MIT Integrated Global System Model (IGSM) consisting of a set of coupled sub-models of economic development and associated emissions, natural biogeochemical cycles, climate, and natural ecosystems (Prinn et al., 1998). There, a CGE model is applied to “predict” emissions used subsequently as an input in the atmospheric chemistry model and the climate model. To date most of the potential feedbacks between the socio-economic and biophysical systems are not formally modeled. Instead, the sub-models use the results of the economic model as exogenous parameters. In other words, there is only a one-way soft link between economic variables and their relationship with biophysical variables. Exceptions with two-way (hard-) links where biophysical variables (such as air quality) affect consumer welfare, labor productivity or capital depreciation include Nordhaus (1994) and Vennemo (1997).

Hard linkages stand out for the direct integration of bottom-up information within top-down (CGE) models. As illustrated initially by Böhringer (1998) in a static stylized CGE model, the bottom-up representation of certain segments within the top-down model is straightforward. In practical application to energy regulation (e.g. Böhringer et al., 2003b and 2003c), the bottom-up representation of major power supply options enhances the transparency and “credibility” of simulated technological responses in electricity production that are triggered by specific nuclear phase-out policies. A similar procedure has been employed in the development of CGE models for integrated assessment of the costs and benefits from climate change policies: Complex relationships in the climate system have first been simplified through appropriate aggregation, i.e. reduced forms of more elaborated climate models (Nordhaus and Yang, 1996; Nordhaus and Boyer, 2000).

Bottom-up indicators may also be directly incorporated into multi-sector, multi-region

CGE models through exogenous coefficients or estimated “meta”-functions. A prominent example is the representation of complex abatement options for non-CO₂ greenhouse gases which are not modeled in detail. Instead, exogenous marginal abatement cost curves for non-CO₂ greenhouse gases based on sophisticated bottom-up analysis are employed (Hayhoe et al., 1999; Reilly et al., 1999). Fæhn and Holmøy (2003) link consumption of material goods to solid waste generation for deposition (CSD 10-11). Xie and Saltzman (2000) use an environmentally extended social accounting matrix to identify three general types of pollution (waste water, smog dust, and solid waste) and include the respective pollution-abatement sectors (CSD 10, 13). Strutt and Anderson (2000) use a comprehensive environmental input-output data set complemented by case studies to project anticipated changes in technology in order to assemble a matrix of environmental coefficients over time. Based on these coefficients they estimate the environmental impact per unit of economic activity in each sector and project environmental outcomes for water use (CSD 28), water pollution (CSD 29) and air pollution (CSD 15-16; EC XII). The water pollution content of the effluent is provided by four measures: biological oxygen demand, chemical oxygen demand, dissolved solids, and suspended solids. Berck et al. (1991) provide an overview of the use of CGE models to assess water regulation which becomes an increasingly important policy issue in drier regions. A major modeling challenge concerns the appropriate representation of water supply and demand (Hertel, 1999). Decaluwe et al. (1997) have addressed this issue in the context of an CGE model of the Moroccan economy in which they investigate the implications of water pricing policies. Supply responses of groundwater and surface water (collected by dams) are modeled stochastically. In contrast, Robinson and Gehlhar (1995) developed a CGE model of Egypt in which land and water are combined in a linear fashion in the sectoral production function.

Complementary model information that can be hard-linked to CGE models may substantially improve the applicability of the CGE approach for problem-tailored SIA in various policy fields such as land use, desertification, agriculture or water management. Difficulties might arise in the reconciliation of top-down and bottom-up data stemming from different data sources. Due to different accounting methods (e.g., different depreciation rules) substantial data adjustments may be necessary before a consistent data base for the hard-linked model is available.

6 CONCLUDING REMARKS

The objective of a sustainable future needs a comprehensive methodology to perform *SIA* quantitatively. An issue that can not be clearly measured will be difficult to improve. In this paper, we tried to sustain the view that CGE models can serve as a useful tools for assessing the impacts of policy interference on environmental quality, economic performance and equity. CGE models can incorporate various important *SD* indicators in a single consistent framework and allow for a systematic quantitative tradeoff analysis.

REFERENCES

- Armington, P. A. (1969), A Theory of Demand for Products Distinguished by Place of Production, *IMF Staff Papers*, 16 (1), 159–178.
- Bhattacharyya, S. C. (1996), Applied General Equilibrium Models for Energy Studies: A Survey, *Energy Economics*, 18, 145-164.
- Berck, P., S. Robinson, and G. Goldman (1991), The use of computable general equilibrium models to assess water policies, in: A. Dinar and D. Zilberman (ed.), *The economics and management of water and drainage in agriculture*, Boston, MA: Kluwer Academic Publishers.
- Bergman, L. (1990), The Development of Computable General Equilibrium Modeling, in: L. Bergman, D. W. Jorgenson and E. Zalai (eds.), *General Equilibrium Modeling and Economic Policy Analysis*, Cambridge, 3-30.
- Bergman, L. and S. Lundgren (1990), General Equilibrium Approaches to Energy Policy Analysis in Sweden, in: L. Bergman, D. W. Jorgenson and E. Zalai (eds.), *General Equilibrium Modeling and Economic Policy Analysis*, Oxford: Basil Blackwell, 351-382.
- Blanchflower, D. G. and A. J. Oswald (1994), *The Wage Curve*. Cambridge, MA: MIT Press.
- Böhringer, C. (1996), *Allgemeine Gleichgewichtsmodelle als Instrument der energie- und umweltpolitischen Analyse. Theoretische Grundlagen und Empirische Anwendung*, Dissertationsschrift, Frankfurt: Peter Lang.
- Böhringer, C. (1998), The Synthesis of Bottom-Up and Top-Down in Energy Policy Modeling, *Energy Economics* 20 (3), 233-248.
- Böhringer, C. (forthcoming), Sustainability Impact Analysis: The Use of Computable General Equilibrium Models, *Économie Internationale*.

- Böhringer, C. und A. Löschel (2002), Economic Impacts of Carbon Abatement Strategies, in: C. Böhringer, M. Finus and C. Vogt, *Controlling Global Warming, Perspectives from Economics, Game Theory and Public Choice*, Cheltenham: Edward Elgar, 98-172.
- Böhringer, C. and A. Löschel (eds.) (forthcoming), *Climate Change Policy and Global Trade*, ZEW Economic Studies, Heidelberg: Physica.
- Böhringer, C., K. Conrad and A. Löschel (2003a), Carbon Taxes and Joint Implementation – An Applied CGE Analysis for Germany and India, *Environmental and Resource Economics*, 24 (1), 49-76.
- Böhringer, C., T. Hoffmann and A. Löschel (2003b), Dismantling Nuclear Power in Europe: Macroeconomic and Environmental Impacts, *ZEW Discussion Paper 03-15*, Mannheim.
- Böhringer, C., A. Müller and M. Wickart (2003c), Economic Impacts of a Premature Nuclear Phase-Out in Switzerland, *Swiss Journal of Economics and Statistics*, 139 (4), 461-505.
- Böhringer, C., T. F. Rutherford, A. Pahlke, U. Fahl and A. Voß (1997), Volkswirtschaftliche Effekte einer Umstrukturierung des deutschen Steuersystems unter besonderer Berücksichtigung von Umweltsteuern, Stuttgart.
- Borges, A. (1986), Applied General Equilibrium Models: An Assessment of their Usefulness for Policy Analysis, *OECD Economic Studies*, 7, 7-43.
- Conrad, K. (1999), Computable General Equilibrium Models for Environmental Economics and Policy Analysis, in: J.C.J.M. van den Bergh (ed.): *Handbook of Environmental and Resource Economics*, Cheltenham, Edward Elgar, 1061-1087.
- Conrad, K. (2001), Computable General Equilibrium Models in Environmental and Resource Economics, in: T. Tietenberg and H. Folmer (eds.): *The International Yearbook of Environmental and Resource Economics 2002/2003*, 66-114.
- Conrad, K. and M. Schröder (1991), An Evaluation of Taxes on Air Pollutant Emissions: An Applied General Equilibrium Approach, *Swiss Journal of Economics and Statistics*, 127 (2), 199-224.
- Decaluwe, B., A. Patry, and L. Savard (1997), When Water is No Longer a Gift From Heaven: A CGE Model of the Moroccan Economy, Paper presented at the DIAL/PARADI Conference on CGE Modeling in Developing Economies, Paris, 4.-5.9.1997.
- EAP (Environmental Action Programme) (1973), *First Environmental Action Plan*, 1973-

- 1977, published in OJ C 112, 20.12.1973.
- EC (European Commission) (1995), *PRIMES*, DG XII, EUR 16713, Brussels.
- EC (European Commission) (1996), *POLES 2.2*, DG XII, EUR 17358, Brussels.
- EC (European Commission) (1999), *EXTERNE: Externalities of Energy*, Vol. 1-10, Brussels 1995/99 (<http://www.ExternE.info>).
- EC (European Commission) (2001), *A Sustainable Europe for a Better World: A European Union Strategy for Sustainable Development*, Commission's proposal to the Gothenburg European Council, COM(2001)264 final, Brussels, 15.5.2001.
- EC (European Commission) (2003a), *Sustainability Impact Assessment of Trade Agreements – Making Trade Sustainable?*, Background Paper, DG Trade Seminar, Brussels, 6-7.2.2003.
- EC (European Commission) (2003b), *Structural Indicators*, Communication from the Commission, COM(2003)585 final, Brussels, 8.10.2003.
- EMF (Energy Modeling Forum) (1996), *Markets for Energy Efficiency, EMF Report 13*, Volume I, Stanford University, Stanford, CA.
- Fæhn T. and E. Holmøy (2003), Trade liberalisation and effects on pollutive emissions to air and deposits of solid waste. A general equilibrium assessment for Norway, *Economic Modelling*, 20, 703-727.
- Francois, J. F. and K. A. Reinert (eds.) (1997), *Applied Methods for Trade Policy Analysis: A Handbook*, New York: Cambridge University Press.
- Friedrich, R. and P. Bickel (eds.) (2001), *Environmental External Costs of Transport*, Berlin: Springer.
- Goulder, L. H. (1995), Effects of Carbon Taxes in an Economy with Prior Tax Distortions: An Intertemporal General Equilibrium Analysis, *Journal of Environmental Economics and Management*, 29, 271-297.
- Goulder, L. H. and S. Schneider (1999), Induced Technological Change, Crowding Out, and the Attractiveness of CO₂ Emissions Abatement, *Resource and Environmental Economics*, 21 (3-4), 211-253.
- Hayhoe, K., A. Jain, H. Pitcher, C. MacCracken, M. Gibbs, D. Wuebbles, R. Harvey, and D. Kruger (1999), Costs of Multigreenhouse Gas Reduction Targets for the USA, *Science*, 286, 905-906.
- Hertel, T. W. (1999), *Applied General Equilibrium Analysis of Agricultural and Resource Policies*, Staff Paper 99-2, Department of Agricultural Economics, Purdue University.

- Hyman, R. C., J. M. Reilly, M. H. Babiker, A. De Masin, and H. D. Jacoby (2003), Modeling Non-CO2 Greenhouse Gas Abatement, *Environmental Modeling and Assessment*, 8 (3), 175-186.
- IMAGE-Team (2001), The IMAGE 2.2 implementation of the SRES scenarios. A comprehensive analysis of emissions, climate change and impacts in the 21st. Century, *RIVM CD-ROM publication 481508018*, National Institute for Public Health and the Environment, Bilthoven, the Netherlands.
- Jorgenson, D. W. and P. J. Wilcoxon (1993), Reducing US Carbon Emissions: An Econometric General Equilibrium Assessment, *Resource and Energy Economics*, 15, 7-25.
- Keuschnigg, C. and W. Kohler (1994), Modeling Intertemporal General Equilibrium: An Application to Austrian Commercial Policy, *Empirical Economics*, 19, 131-164.
- Kirkpatrick, C. and N. Lee (1999), *WTO New Round Sustainability Assessment Study, Phase Two Main Report* (Manchester Study), Institute for Development Policy and Management and Environmental Impact Assessment Centre, University of Manchester (<http://www.idpm.man.ac.uk/sia-trade>).
- Klepper, G., J.-O. Lorz, F. Stähler, R. Thiele and M. Wiebelt (1994), Empirische allgemeine Gleichgewichtsmodelle – Struktur und Anwendungsmöglichkeiten, *Jahrbücher für Nationalökonomie und Statistik*, 213, 513-544.
- Lau, M. I., A. Pahlke and T. F. Rutherford (2002), Approximating Infinite-horizon Models in a Complementarity Format: A Primer in Dynamic General Equilibrium Analysis, *Journal of Economic Dynamics and Control*, 26, 577-609.
- Lee, N. and C. Kirkpatrick (2001), Methodologies for Sustainability Impact Assessments of Proposals for New Trade Agreements, *Journal of Environmental Assessment Policy and Management*, 3 (3), 395-412.
- Löschel, A. (2002), Technological Change in Economic Models of Environmental Policy: A Survey, *Ecological Economics*, 43, 105-126.
- Mansur, A. and J. Whalley (1984), Numerical Specification of Applied General Equilibrium Models: Estimation, Calibration, and Data, in: H. E. Scarf. and J. B. Shoven (eds.), *Applied General Equilibrium Analysis*, New York: Cambridge University Press, 69-127.
- Nordhaus, W. D. (1994), Rolling the “DICE”: An Optimal Transition Path for Controlling Greenhouse Gases, *Resource and Energy Economics*, 15, 27-50.

- Nordhaus, W. D. and J. Boyer (2000), *Warming the World: Economic Models of Global Warming*, Boston, MA: MIT Press.
- Nordhaus, W. D. and Z. Yang (1996), A Regional Dynamic General-Equilibrium Model of Alternative Climate-Change Strategies, *American Economic Review*, 86, 741-765.
- Parris, T. M. and R. W. Kates (2003), Characterizing and Measuring Sustainable Development, *Annual Review of Environment and Resources*, 28, 559-586.
- Prinn, R., H. Jacoby, A. Sokolov, C. Wang, X. Xiao, Z. Yang, R. Eckaus, P. Stone, D. Ellerman, J. Melillo, J. Fitzmaurice, D. Kicklighter, G. Holian, and Y. Liu May (1998), Integrated Global System Model for climate policy assessment: Feedbacks and sensitivity studies, *Climatic Change*, 41 (3/4), 469-546).
- Rasmussen, T. N. and T.F. Rutherford (forthcoming), Modeling Overlapping Generations in a Complementarity Format, *Journal of Economic Dynamics and Control*.
- Reilly, J., R. Prinn, J. Harmisch, J. Fitzmaurice, H. Jacoby, D. Kicklighter, J. Melillo, P. Stone, A. Sokolov, and C. Wang (1999), Multiple Gas Assessment of the Kyoto Protocol, *Nature*, 401, 549-555.
- Robinson, S. and C. Gehlhar (1995), Land, Water and Agriculture in Egypt: The Economy-wide Impact of Policy Reform, IFPRI TMD Discussion Paper 1, Washington, D.C.
- Shoven, J. B. and J. Whalley (1992), *Applying General Equilibrium*, Cambridge, Cambridge University Press.
- Strutt, A. and K. Anderson (2000), Will Trade Liberalization Harm the Environment? The Case of Indonesia to 2020, *Environmental and Resource Economics*, 17, 203–232.
- Tamborra, M (2002), Socio-Economic Tools For Sustainability Impact Assessment - The Contribution of EU Research To Sustainable Development, European Communities, Office for Official Publications of the European Communities, Luxembourg.
- UN (United Nations) (2001) *Indicators of Sustainable Development: Guidelines and Methodologies*, New York.
- UNCED (The United Nations Conference on Environment and Development, Earth Summit) (1992a), *Rio Declaration on Environment and Development*, Rio de Janeiro, 3.–14.6.1992.
- UNCED (The United Nations Conference on Environment and Development, Earth Summit) (1992b), *Agenda 21*, Rio de Janeiro, 3.–14.6.1992.
- U.S. Department of Commerce (1993), Input-Output Table of the U.S. Economy, 1987, Bureau of Economic Analysis, Washington, DC.

- Van Herbruggen, B. (2002), *In Depth Description of the TREMOVE Model*, Transport & Mobility Leuven, March 2002, Leuven.
- Vennemo, H. (1997), A Dynamic Applied General Equilibrium Model with Environmental Feedbacks, *Economic Modeling*, 14, 99-154.
- WCED (World Commission on Environment and Development, The Brundtland Commission) (1987), *Our Common Future*, Oxford: Oxford University Press.
- Xie, J. and S. Saltzman (2000), Environmental Policy Analysis: An Environmental Computable General-Equilibrium Approach for Developing Countries, *Journal of Policy Modeling*, 22(4), 453–489.
- Young, H. P. (1994), *Equity in Theory and Practice*, Princeton, N.J.: Princeton University Press.