

Naimzada, Ahmad; Tramontana, Fabio

Working Paper

Double route to chaos in an heterogeneous triopoly game

Quaderni di Dipartimento, No. 149

Provided in Cooperation with:

University of Pavia, Department of Economics and Quantitative Methods (EPMQ)

Suggested Citation: Naimzada, Ahmad; Tramontana, Fabio (2011) : Double route to chaos in an heterogeneous triopoly game, Quaderni di Dipartimento, No. 149, Università degli Studi di Pavia, Dipartimento di Economia Politica e Metodi Quantitativi (EPMQ), Pavia

This Version is available at:

<https://hdl.handle.net/10419/95262>

Standard-Nutzungsbedingungen:

Die Dokumente auf EconStor dürfen zu eigenen wissenschaftlichen Zwecken und zum Privatgebrauch gespeichert und kopiert werden.

Sie dürfen die Dokumente nicht für öffentliche oder kommerzielle Zwecke vervielfältigen, öffentlich ausstellen, öffentlich zugänglich machen, vertreiben oder anderweitig nutzen.

Sofern die Verfasser die Dokumente unter Open-Content-Lizenzen (insbesondere CC-Lizenzen) zur Verfügung gestellt haben sollten, gelten abweichend von diesen Nutzungsbedingungen die in der dort genannten Lizenz gewährten Nutzungsrechte.

Terms of use:

Documents in EconStor may be saved and copied for your personal and scholarly purposes.

You are not to copy documents for public or commercial purposes, to exhibit the documents publicly, to make them publicly available on the internet, or to distribute or otherwise use the documents in public.

If the documents have been made available under an Open Content Licence (especially Creative Commons Licences), you may exercise further usage rights as specified in the indicated licence.

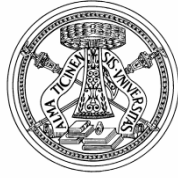

Quaderni di Dipartimento

**Double route to chaos in an heterogeneous
triopoly game**

Ahmad Naimzada
(Università di Milano-Bicocca)

Fabio Tramontana
(Università di Pavia)

149 (06-11)

Dipartimento di economia politica
e metodi quantitativi
Università degli studi di Pavia
Via San Felice, 5
I-27100 Pavia

Giugno 2011

Double route to chaos in an heterogeneous triopoly game

Ahmad Naimzada
University of Milano-Bicocca

Fabio Tramontana
University of Pavia
Department of Economics and Quantitative Methods
Via S.Felice 7, 27100 Pavia, Italy
fabio.tramontana@unipv.it

June 27, 2011

Abstract

We move from a triopoly game with heterogeneous players (E.M.Elabbassy et al., 2009. Analysis of nonlinear triopoly game with heterogeneous players. Computers and Mathematics with Applications 57, 488-499). We remove the nonlinearity from the cost function and introduce it in the demand function. We also introduce a different decisional mechanism for one of the three competitors. A double route to complex dynamics is shown to exist, together with the possibility of multistability of different attractors, requiring a global analysis of the dynamical system.

keywords: Triopoly game; Heterogeneous players; Global analysis

1 Introduction

Oligopoly is the market structure in which the consequences of the bounded rationality of economic agents are more evident. In this kind of markets a higher level of rationality is required in order to make the best choice. In fact, firms do not only have to know the shape of the demand function, but they also have to be able to foresee the output choices of the competitors, because they are in a situation of *strategic interdependence* caused by the influence of each single firm on the market price. In the literature, a lot of papers are devoted to the development and the analysis of the simplest oligopolistic case: duopoly. Both homogeneous and heterogeneous firms cases are considered¹ (see [1-6] for

¹In this branch of literature the terms *homogeneous* and *heterogeneous* refer to the decisional mechanism adopted by the firms.

a few papers on homogeneous duopolies, [7] for a recent survey and [8-12] for heterogeneous ones). The authors of these papers underscore the complicated (and complex) dynamics that may emerge whenever firms have some degree of bounded rationality. A more complicated case is the case of triopoly. Differently with respect to duopolies, the case with three firms is not present in the literature as well. One of the main reasons behind this low number of triopoly papers, lies on the complexity of the models describing the dynamics of the quantities that must be at least three-dimensional. Only under some particular restriction it is still possible to analytically study this kind of models. For example, it is almost always possible to deal with the equations governing the dynamics of homogeneous triopolies (see [13-17] for some examples), at least for what concerns the local stability of Nash equilibria. More difficult to study, but more realistic, is the case with three heterogeneous firms. In such a case the study must be necessarily performed by instruments both analytic and numeric. The development of quite powerful computers, permits now to be able to handle this case (see [18-20]).

To the best of our knowledge, in the triopoly games already studied, the only road to complexity is a cascade of period doubling bifurcations, leading to chaos². Such a case only produce realistic disequilibrium dynamics for the combinations of parameters for which a chaotic attractor is reached. In fact, it appears quite unrealistic in the long period the persistence of periodic dynamics. Even if the firms are assumed to be boundedly rational, it seems reasonable that they are able to recognize a periodic path, modifying as a consequence their decisional process. In heterogeneous duopoly games like [10-12] the possibility that the Nash equilibrium loses stability via flip bifurcation, is always accompanied with the possibility to observe a Neimark-Sacher bifurcation, for some values of the parameters. This is, in our opinion, a quite realistic scenario in which, after the bifurcation, orbits display a quasiperiodic motion, that require an higher degree of rationality for the firms in order to be recognized. In [11,12] the double route to complex dynamics seems to be somehow related with the assumption of isoelastic demand function. In the present model we analyze an heterogeneous triopoly model taking [19] as a benchmark. We adopt the following alternative assumptions with respect to [19]:

- We adopt a microfounded isoelastic demand function (see Puu [1]) and linear costs, instead of a linear demand function and quadratic costs;
- We assume a different decisional mechanism for one of the three players: instead of the adaptive player we introduce a firm that approximates the demand function linearly around the last realized couple of quantity and market price (see [5,22,23])

We show that these assumptions permit to obtain the double route to chaos already founded in some heterogeneous duopoly. Moreover, we numerically found multistability of different coexistent attractors, and we perform a global analysis through numerical simulations in order to identify the basins of attraction

²With the exception of a working paper of one of the authors [21].

of the attractors, that is the initial conditions leading to one attractor or the other. The paper is organized as follows: in Section 2 we introduce the model whose Nash equilibrium is obtained in Section 3 together with its local stability. Section 4 is devoted to the close examination of the Flip bifurcation of the Nash equilibrium. Section 5 concerns the Neimark-Sacher bifurcation of the Nash equilibrium, while in Section 6 we show the ambiguous role of the marginal costs. Multistability and some numerical global analysis are in Section 7. Section 8 concludes.

2 The model

Let us consider a market populated by three firms producing homogeneous goods. The demand function is isoelastic, implying the hypothesis of Codd-Douglas utility function of the consumers (see Puu [1]):

$$p = f(Q) = \frac{1}{Q} = \frac{1}{q_1 + q_2 + q_3}, \quad (1)$$

where Q is the total supply and q_i , $i = 1, 2, 3$ represents the level of production of the i -th triopolist. The cost function is linear:

$$C_i(q_i) = c_i q_i, \quad (2)$$

where c_i for $i = 1$ to 3 are the constant marginal costs.

The first player does not know the shape of the demand function and at each time period t it builds a *conjectured demand function* through the local knowledge of the real demand function (1). In particular, the firm observes the current market price $p(t)$ and the corresponding total supplied quantity $Q(t)$. By using market experiments, the player is able to linearly approximate the demand function around the point $(Q(t), p(t))$. In other words, it obtains the slope of the demand function in that point and, in the absence of other information, it conjectures the linearity of the demand function that must pass through the point corresponding to the current market price and quantity (see [5,21,22]). Given this assumption, the first player defines the conjectured demand for the following period $t + 1$:

$$p_1^e(t + 1) = p(t) + f'(Q(t))(Q^e(t + 1) - Q(t)), \quad (3)$$

where $f'(Q(t))$ is the inverse demand function, and $Q^e(t + 1)$ represents the aggregate conjectured production for time $t + 1$. By using the demand function we obtain:

$$p_1^e(t + 1) = f(Q(t)) + f'(Q(t))(q_1(t + 1) + q_2^e(t + 1) + q_3^e(t + 1) - Q(t)) \quad (4)$$

Concerning the expectations about the rivals' outputs, we use the cournotian hypothesis of static expectations, then the expected quantities for the next

period are the same supplied in the current one. By using this assumption in (4) we have:

$$p_1^e(t+1) = f(Q(t)) + f'(Q(t))(q_1(t+1) - q_1(t)) \quad (5)$$

The choice of $q_1(t+1)$ is made in order to maximize the expected profit:

$$q_1(t+1) = \operatorname{argmax}_{q_1(t+1)} \pi_1^e(t+1) = \operatorname{argmax}_{q_1(t+1)} [p_1^e(t+1)q_1(t+1) - c_1q_1(t+1)] \quad (6)$$

The first order condition is the following:

$$\frac{\partial \pi_1^e(t+1)}{\partial q_1(t+1)} = f(Q(t)) + 2q_1(t+1)f'(Q(t)) - q_1(t)f'(Q(t)) - c_1 = 0 \quad (7)$$

It is easy to verify the second order condition. So, the evolution of the output of the first player is given the following first order nonlinear difference equation:

$$q_1(t+1) = \frac{q_1(t)}{2} + \frac{c_1 - f(Q(t))}{2f'(Q(t))} \quad (8)$$

that is:

$$q_1(t+1) = \frac{2q_1(t) + q_2(t) + q_3(t) - c_1(q_1(t) + q_2(t) + q_3(t))^2}{2} \quad (9)$$

The second player knows the shape of the demand function but it has to conjecture the choices of the other two players. We assume that it also is a *naïve* player, that is it uses static expectations like the first player and then it maximize the expected profit given by:

$$q_2(t+1) = \operatorname{argmax}_{q_2(t+1)} \pi_2^e(t+1) = \operatorname{argmax}_{q_2(t+1)} [p_2^e(t+1)q_2(t+1) - c_2q_2(t+1)] \quad (10)$$

By using the demand function (1) and static expectations we obtain:

$$q_2(t+1) = \operatorname{argmax}_{q_2(t+1)} \pi_2^e(t+1) = \operatorname{argmax}_{q_2(t+1)} \left[\frac{q_2(t+1)}{q_1(t) + q_2(t+1) + q_3(t)} - c_2q_2(t+1) \right] \quad (11)$$

that permits to derive the dynamic equation:

$$q_2(t+1) = \sqrt{\frac{q_1(t) + q_3(t)}{c_2}} - q_1(t) - q_3(t) \quad (12)$$

The third player adopts the so-called *myopic* adjustment mechanism (see Dixit [24]), that is:

$$q_3(t+1) = q_3(t) + \alpha q_3(t) \phi_3(Q(t)), \quad (13)$$

where $\phi_3(Q(t))$ is the marginal profit of the third triopolist, that is:

$$\phi_3(Q(t)) = \phi_3(q_1(t) + q_2(t) + q_3(t)) = \frac{\partial \pi_3(q_1(t) + q_2(t) + q_3(t))}{\partial q_3(t)} = \frac{q_1(t) + q_2(t)}{(q_1(t) + q_2(t) + q_3(t))^2} - c_3, \quad (14)$$

In other words, the third firm increases/decreases its output according to the information given by the marginal profit of the last period. The positive parameter α represents the speed of adjustment. By substituting (14) in (13) we finally obtain the dynamic equation:

$$q_3(t+1) = q_3(t) + \alpha q_3(t) + \left[\frac{q_1(t) + q_2(t)}{(q_1(t) + q_2(t) + q_3(t))^2} - c_3 \right] \quad (15)$$

If we use x, y, z instead of q_1, q_2, q_3 in (9),(12) and (15) we have that the dynamics of the firms' outputs are given by the following discrete time dynamical system:

$$(x', y', z') = T(x, y, z) : \begin{cases} x' = \frac{2x + y + z - c_1(x + y + z)^2}{2} \\ y' = \sqrt{\frac{x+z}{c_2}} - x - z \\ z' = z + \alpha z \left[-c_3 + \frac{x+y}{(x+y+z)^2} \right] \end{cases} \quad (16)$$

where $'$ denotes the unit-time advancement operator.

3 Nash Equilibrium stability

In order to analyze the relationship between the stationary state of the dynamical system (16) and the Nash equilibrium, we must seek the equilibrium point as the solution of the following algebraic system:

$$\begin{cases} \frac{y^* + z^* - c_1(x^* + y^* + z^*)^2}{2} = 0 \\ \sqrt{\frac{x^* + z^*}{c_2}} - x^* - y^* - z^* = 0 \\ z^* \left[-c_3 + \frac{x^* + y^*}{(x^* + y^* + z^*)^2} \right] = 0 \end{cases} \quad (17)$$

which is obtained by setting $x' = x = x^*$, $y' = y = y^*$ and $z' = z = z^*$ in (16). The algebraic system (17) is solved by the origin O and by the point:

$$E : \left(\frac{2(c_2 + c_3 - c_1)}{(c_1 + c_2 + c_3)^2}; \frac{2(c_1 + c_3 - c_2)}{(c_1 + c_2 + c_3)^2}; \frac{2(c_1 + c_2 - c_3)}{(c_1 + c_2 + c_3)^2} \right). \quad (18)$$

We do not consider the origin O because our map is not defined in such a point. It is possible to prove (see [5,23]) that E is the only other stationary state of the system. It is the Nash Equilibrium of the static game. We note that such equilibrium is the same equilibrium obtained by Puu [13] in an equivalent triopoly setting. The Jacobian matrix of the map T is the following:

$$J(x, y, z) : \begin{bmatrix} 1 - b(x + y + z) & \frac{1}{2} [1 - 2c_1(x + y + z)] & \frac{1}{2} [1 - 2c_1(x + y + z)] \\ \left(\frac{x+z}{c_2} \right)^{-\frac{1}{2}} \frac{1}{2c_2} - 1 & 0 & \left(\frac{x+z}{c_2} \right)^{-\frac{1}{2}} \frac{1}{2c_2} - 1 \\ \alpha z \left[\frac{z-x-y}{(x+y+z)^3} \right] & \alpha z \left[\frac{z-x-y}{(x+y+z)^3} \right] & 1 - \alpha c_3 + \alpha(x + y) \left[\frac{x+y-z}{(x+y+z)^3} \right] \end{bmatrix}$$

In order to analyze the local stability of the Nash equilibrium, you need to evaluate the Jacobian matrix at the Nash equilibrium and calculate the eigenvalues. Unfortunately, it is not possible to find them analytically. We can still say something through numerical simulations. After several numerical computations, we have found that a generic two-dimensional bifurcation diagram in the (α, c_3) parameters' plane, is always qualitatively similar to the one represented in Fig. 1.

————— FIG. 1 HERE —————

Fig. 1 is representative of the ways by which the Nash equilibrium becomes unstable. We can see a double route to instability: by period doubling or by Neimark-Sacker bifurcation.

4 Flip bifurcation

The first one is via period-doubling bifurcation (also called Flip bifurcation). This kind of local bifurcation is not new in the literature on both homogeneous and heterogeneous triopolies (see [1-20]). It occurs when moving the value of a parameter, one of the eigenvalues of the Jacobian matrix calculated at the Nash equilibrium, becomes lower than -1 , while the other two are still lower than 1 in absolute value. A 2-cycle appears and it attracts all the orbits previously attracted by the fixed point. The bifurcation diagram at Fig.2 shows that this is what happens by increasing the value of the speed of reaction parameter α , keeping fixed the marginal costs at $c_1 = 0.5$, $c_2 = 0.55$ and $c_3 = 0.15$ (the direction A in Fig.1).

————— FIG. 2 HERE —————

The bifurcation diagram also shows that if we keep increasing the value of α a cascade of period doubling bifurcations occurs (see the bifurcation diagram in Fig. 2a). This is a typical route to chaos, as it is confirmed but the maximal Lyapunov exponent, in Fig. 2b. A chaotic attractor in the three-dimensional phase plane is showed in Fig. 3b.

————— FIG. 3 HERE —————

5 Neimark-Sacker bifurcation

Another route to complicated dynamics occurs whenever the Nash equilibrium undergoes a Neimark-Sacker bifurcation (NS bifurcation henceforth). This happens when, increasing the value of α the system enters in the yellow region of the parameters plane in Fig. 1. Fig. 4a shows the locally attractive closed invariant curve that is created after the local bifurcation. Differently from the flip bifurcation case, now the dynamics are quasi-periodic. A further increasing

in the value of α may lead to chaotic dynamics (as proved by the numerical computation of the maximal Lyapunov exponent in Fig.5b). The annular chaotic attractor is showed in Fig. 4b. The double route to chaos (via NS and via flip bifurcation) is new with respect to [19] and also respect to the other triopoly games. This is an important feature from an economic point of view, because it means that firms may face both periodic and quasi-periodic dynamics. While the former can be recognized by a rational enough firm, the latter are very hard to detect by looking at the time series of the quantities. This means that immediately after the NS bifurcation the system displays complicated dynamics, differently from what happens after the period doubling bifurcation in which a periodic attractor appears.

————— FIG. 4 AND 5 HERE —————

6 The role of the marginal costs

The two-dimensional bifurcation diagram in Fig.1 permits us to also say something about the role played by the marginal costs. We can see the this role is ambiguous, especially for high values of the speed of adjustment. In fact, it is possible to have a situation in which for low values of the marginal cost the Nash equilibrium is unstable and the orbits converge to a chaotic attractor or a closed invariant curve. For intermediate values of α the Nash equilibrium is locally stable but increasing again the marginal cost it loses stability via flip bifurcation and then, with higher values of α the Nash equilibrium becomes locally stable again (see the bifurcation diagram in Fig.6).

————— FIG. 6 HERE —————

Note the qualitatively nothing would change in Fig.1 by using c_1 or c_2 instead of c_3 .

7 Global Analysis

In this section we present the main novelty of this model with respect to the other heterogeneous triopolies already studied in the literature. Until now we limited our analysis to the local stability of the Nash equilibrium. We have also shown that the positivity of the Nash equilibrium implies that the other fixed points are locally unstable. This is also what happens in the other triopolies studied so far. The Nash equilibrium, or the attractor originating from its loss of stability, was not only locally attracting but to it are asymptotically directed all the feasible trajectories (i.e. those that are not divergent). This is not what happens in our triopoly game. In fact, we can find sets of parameters leading to a bistability of different attractors. Fig. 7b shows the locally stable Nash equilibrium coexisting with a locally stable 3-cycle whose points are located

around it. From the bifurcation diagram of Fig. 7a we can see that the 3-cycle becomes unstable by increasing the value of α , giving rise to a higher periodicity cycles, and even to a chaotic attractor. Nevertheless the Nash Equilibrium still remains locally stable.

————— FIG. 7 HERE —————

This is not only a new feature interesting from a mathematical point of view. Coexistence has a lot of economic consequences. The two coexisting attractors are characterized by quite different levels of variance of the quantities produced by the triopolists. In one case what will happen in the future is much more predictable with respect to the other one. Initial conditions assume a crucial importance in determining to which attractor the system will asymptotically converge. So, besides the local analysis of the Nash equilibrium, we need to perform some kind of global analysis. In Fig. 8 we can see three different sections of the basins of attractions in a situation of coexistence between the locally stable NE (whose basin of attraction is made up by blue points) and a locally stable 3-cycle (whose basin of attraction is in red). The structure of the basins appear quite complicated and this is probably a consequence of the non-invertibility of the map (16).

————— FIG. 8 HERE —————

The shapes of the basins of attractions when the Nash Equilibrium coexists with a chaotic attractor (Fig. 9) are complicated as well. This permit us to conclude that this heterogeneous triopoly is characterized by an higher degree of unpredictability with respect to other similar models present in the literature.

————— FIG. 9 HERE —————

8 Conclusions

A triopoly game with heterogeneous players is analyzed in this paper. Nonlinearities are present both in the demand function and in the decisional mechanism adopted by the firms. We have numerically proved the existence of two different route to complex dynamics: through a flip bifurcation and through Neimark-Sacher bifurcation of the Nash equilibrium. Another important feature of this model is the arising, for some parameters' constellation, of multistability between two different attractors. We have numerically performed some global analysis show how complicated can be the basins of attractions.

References

- [1] T. Puu, Chaos in duopoly pricing, *Chaos Solitons Fractals* 1 (1991) 573-581.
- [2] M. Kopel, Simple and complex adjustment dynamics in Cournot duopoly models, *Chaos Solitons Fractals* 7 (1996) 2031-2048.
- [3] H.N. Agiza, On the analysis of stability, bifurcation, chaos and chaos control of Kopel map, *Chaos Solitons Fractals* 10 (1999) 1909-1916.
- [4] G.I. Bischi, M. Kopel, Equilibrium selection in a nonlinear duopoly game with adaptive expectations, *J. Econ. Behav. Organ.* 46 (2001) 73-100.
- [5] A. Naimzada, L. Sbragia, Oligopoly games with nonlinear demand and cost functions: two boundedly rational adjustment processes, *Chaos Solitons Fractals* 29 (2006) 707-722.
- [6] F. Tramontana, L. Gardini, T. Puu, Cournot duopoly when the competitors operate multiple production plants, *J. Econ. Dynam. Contr.* 33 (2009) 250-265.
- [7] G.I. Bischi, C. Chiarella, M. Kopel, F. Szidarovsky, *Nonlinear Oligopolies: Stability and Bifurcations*, first ed., Springer-Verlag, New York, 2009.
- [8] H.N. Agiza, A.A. Elsadany, Nonlinear dynamics in the Cournot duopoly game with heterogeneous players, *Physica A* 320 (2003) 512-524.
- [9] H.N. Agiza, A.A. Elsadany, Chaotic dynamics in nonlinear duopoly game with heterogeneous players, *Appl. Math. Comput.* 149 (2004) 843-860.
- [10] J. Zhang, Q. Da, Y. Wang, Analysis of nonlinear duopoly game with heterogeneous players, *Econ. Modelling* 24 (2007) 138-148.
- [11] N. Angelini, R. Dieci, F. Nardini, Bifurcation analysis of a dynamic duopoly model with heterogeneous costs and behavioural rules, *Math. Comput. Simul.* 79 (2009) 3179-3196.
- [12] F. Tramontana, Heterogeneous duopoly with isoelastic demand function, *Econ. Modelling* 27 (2010) 350-357.
- [13] T. Puu, Complex dynamics with three oligopolists, *Chaos Solitons Fractals* 7 (1996) 2075-2081.
- [14] H.N. Agiza, Explicit stability zones for Cournot games with 3 and 4 competitors, *Chaos Solitons Fractals* 9 (1998) 1955-1966.
- [15] H.N. Agiza, G.I. Bischi, M. Kopel, Multistability in a dynamic Cournot game with three oligopolists, *Math. Comput. Simul.* 51 (1999) 63-90.
- [16] A. Agliari, L. Gardini, T. Puu, The dynamics of a triopoly Cournot game, *Chaos Solitons Fractals* 11 (2000) 2531-2560.

- [17] H. Richter, A. Stolk, Control of the triple chaotic attractor in a Cournot triopoly model, *Chaos Solitons Fractals* 20 (2004) 409-413.
- [18] E.M. Elabbasy, H.N. Agiza, A.A. Elsadany, H. EL-Metwally, The dynamics of triopoly game with heterogeneous players, *Int. J. Nonlinear Sci.* 3 (2007) 83-90.
- [19] E.M. Elabbasy, H.N. Agiza, A.A. Elsadany, Analysis of nonlinear triopoly game with heterogeneous players, *Comp. Math. Appl.* 57 (2009) 488-499.
- [20] W. Ji, Chaos and control of game model based on heterogeneous expectations in electric power triopoly, *Discrete Dynamics in Nature and Society*, Volume 2009 (2009), Article ID 469564, 8 pages.
- [21] A.A. Elsadany, F. Tramontana, Heterogeneous triopoly game with isoelastic demand function. Mimeo.
- [22] J. Tuinstra, A price adjustment process in a model of monopolistic competition, *Int. Game Theory Rev.* 6 (2004) 417-442.
- [23] G.I. Bischi, A. Naimzada, L. Sbragia, Oligopoly games with local monopolistic approximation, *J. Econ. Behav. Organ.* 62 (2007) 371-388.
- [24] A. Dixit, Comparative statics for oligopoly, *Int. Econ. Rev.* 27 (1986) 107-122.

FIGURES

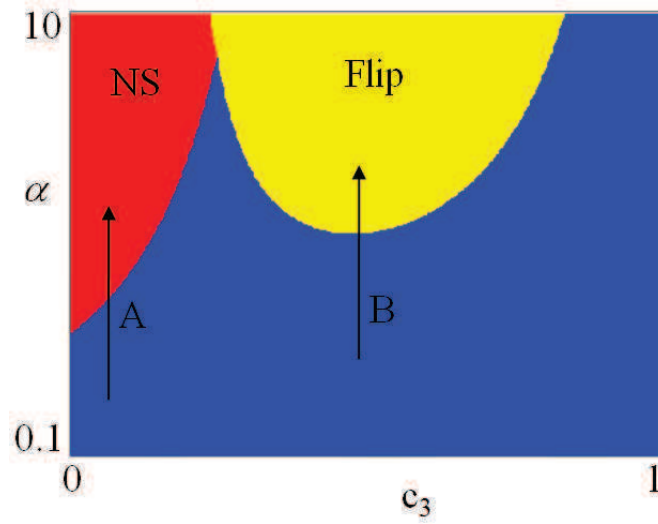

Figure 1: Two-dimensional bifurcation diagram in the (c_2, α) parameters plane. The value of c_1 is fixed to 0.5, while $c_2 = 0.55$. In the blue region the Nash Equilibrium is locally stable. In the red region of eigenvalue is lower than -1, while in the yellow region a couple of complex and conjugated eigenvalues has a modulus higher than 1.

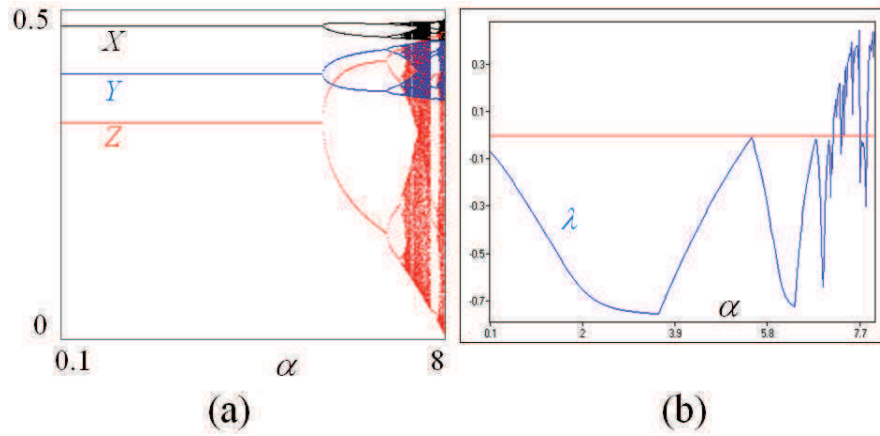

Figure 2: In (a) one-dimensional bifurcation diagram with respect to the parameter α . The fixed parameters are: $c_1 = 0.4$, $c_2 = 0.55$ and $c_3 = 0.6$. In (b) the corresponding maximum Lyapunov exponent, displaying a chaotic behavior for high values of α .

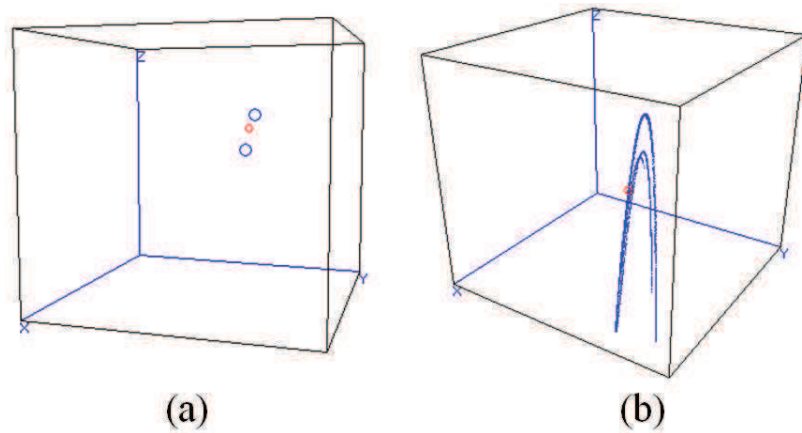

Figure 3: In (a) a 2-cycle obtained with $\alpha = 6.5$. The chaotic attractor in (b) is obtained by using $\alpha = 8$.

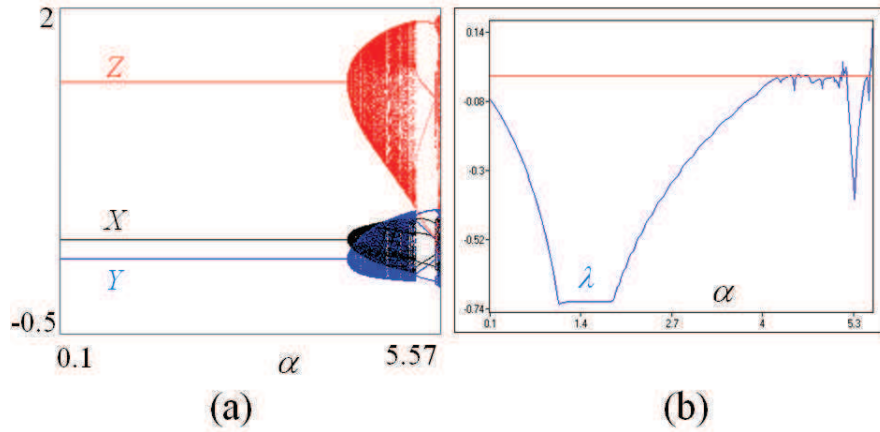

Figure 4: In (a) one-dimensional bifurcation diagram with respect to the parameter α . The fixed parameters are: $c_1 = 0.4$, $c_2 = 0.55$ and $c_3 = 0.1$. In (b) the corresponding maximum Lyapunov exponent, displaying a chaotic behavior for high values of α .

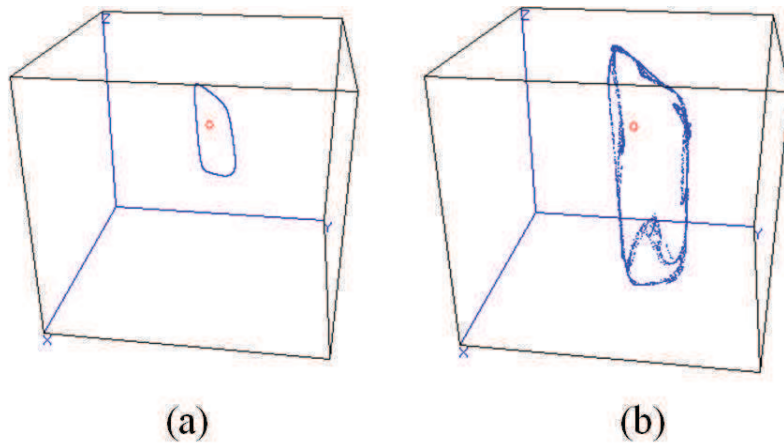

Figure 5: In (a) an attracting closed invariant curve obtained with $\alpha = 4.476$. The annular chaotic attractor in (b) is obtained by using $\alpha = 5.57$.

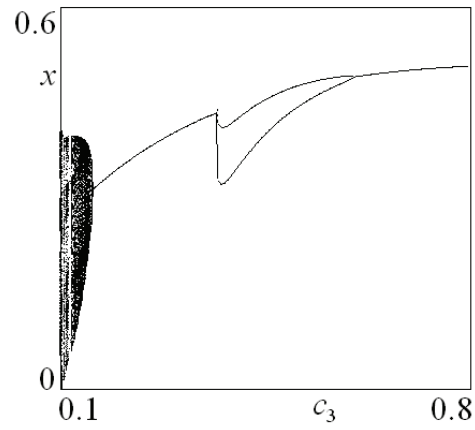

Figure 6: One-dimensional bifurcation diagram obtained by varying the marginal cost c_3 and keeping fixed the other parameters at the values $c_1 = 0.5$, $c_2 = 0.55$ and $\alpha = 0.55$.

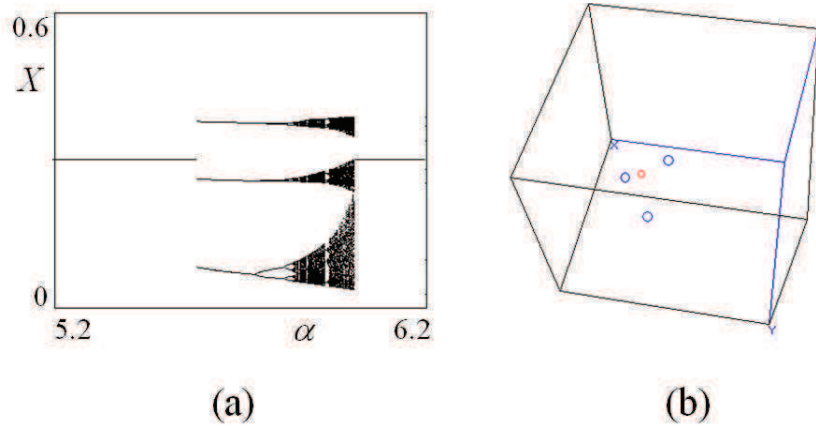

Figure 7: In (a) one-dimensional bifurcation diagram with $c_1 = 0.5$, $c_2 = 0.55$ and $c_3 = 0.2$. α varies between 5.2 and 6.2. The sudden jump from the fixed point to a 3-cycle is caused by the initial conditions that enter the basin of attraction of the 3-cycle. In (b) the Nash Equilibrium coexisting with a locally stable 3-cycle at $\alpha = 5.66$.

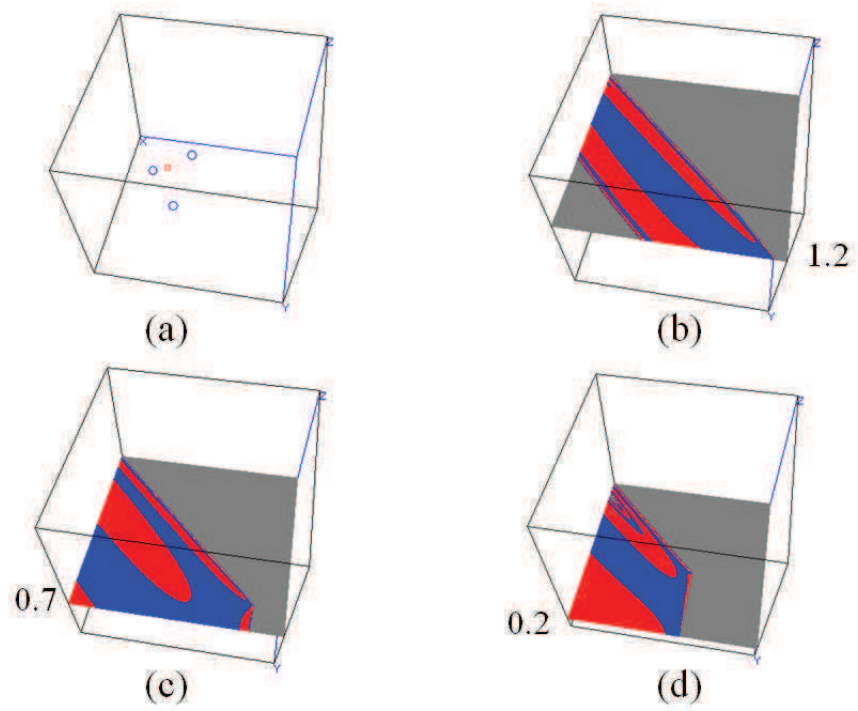

Figure 8: 4 different sections of the basins attraction of the coexisting Nash Equilibrium (basin in blue) and 3-cycle (basin in red). In grey the basin of attraction of diverging trajectories.

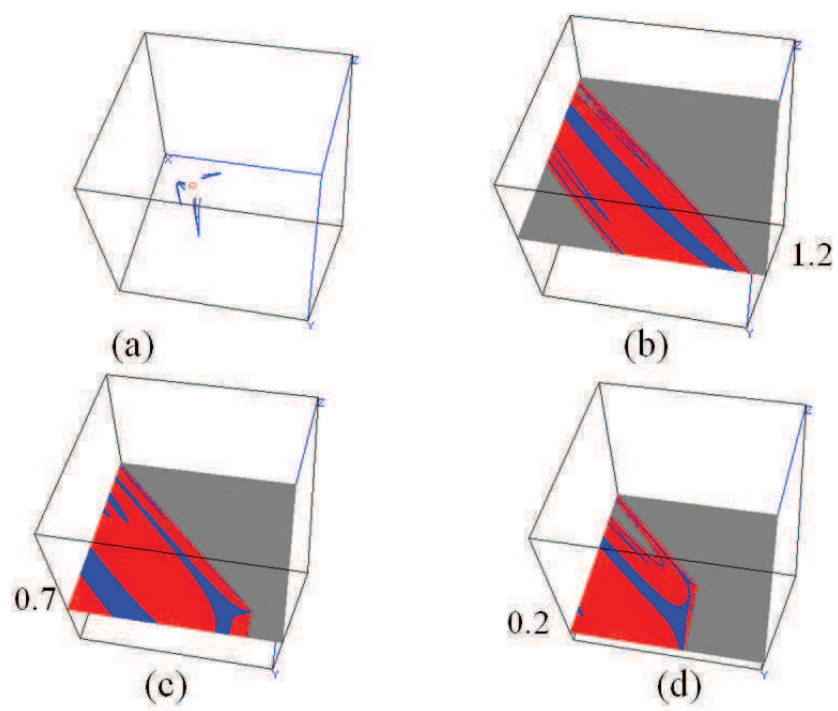

Figure 9: 4 different sections of the basins attraction of the coexisting Nash Equilibrium (basin in blue) and 3-pieces chaotic attractor (basin in red). In grey the basin of attraction of diverging trajectories.