

Kellner, Christian; Thordal-Le Quement, Mark

Working Paper

Mode of ambiguous communication

Bonn Econ Discussion Papers, No. 10/2013

Provided in Cooperation with:

Bonn Graduate School of Economics (BGSE), University of Bonn

Suggested Citation: Kellner, Christian; Thordal-Le Quement, Mark (2013) : Mode of ambiguous communication, Bonn Econ Discussion Papers, No. 10/2013, University of Bonn, Bonn Graduate School of Economics (BGSE), Bonn

This Version is available at:

<https://hdl.handle.net/10419/92983>

Standard-Nutzungsbedingungen:

Die Dokumente auf EconStor dürfen zu eigenen wissenschaftlichen Zwecken und zum Privatgebrauch gespeichert und kopiert werden.

Sie dürfen die Dokumente nicht für öffentliche oder kommerzielle Zwecke vervielfältigen, öffentlich ausstellen, öffentlich zugänglich machen, vertreiben oder anderweitig nutzen.

Sofern die Verfasser die Dokumente unter Open-Content-Lizenzen (insbesondere CC-Lizenzen) zur Verfügung gestellt haben sollten, gelten abweichend von diesen Nutzungsbedingungen die in der dort genannten Lizenz gewährten Nutzungsrechte.

Terms of use:

Documents in EconStor may be saved and copied for your personal and scholarly purposes.

You are not to copy documents for public or commercial purposes, to exhibit the documents publicly, to make them publicly available on the internet, or to distribute or otherwise use the documents in public.

If the documents have been made available under an Open Content Licence (especially Creative Commons Licences), you may exercise further usage rights as specified in the indicated licence.

Bonn Econ Discussion Papers

Discussion Paper 10/2013

Mode of Ambiguous Communication

by

Christian Kellner, Mark T. Le Quement

November 2013



Bonn
Graduate
School of
Economics

Bonn Graduate School of Economics
Department of Economics
University of Bonn
Kaiserstrasse 1
D-53113 Bonn

Financial support by the
Deutsche Forschungsgemeinschaft (DFG)
through the
Bonn Graduate School of Economics (BGSE)
is gratefully acknowledged.

Deutsche Post World Net is a sponsor of the BGSE.

Modes of ambiguous communication*

Christian Kellner and Mark T. Le Quement
University of Bonn

Abstract

We study cheap talk communication in a simple two actions-two states model featuring ambiguous priors. First, we find that in equilibrium, S typically mixes between messages triggering different behavior by R while R himself mixes after some message. Technically, the mixing performed by S is equivalent to mixing over classical partitional strategies. We interpret mixing by respectively S or R as embodying two different modes of ambiguous communication. Second, we find that for sufficiently high ambiguity, more than two messages are often necessary to implement the optimal decision rule of S, though only two actions are available to R. If only two messages are available and S faces his preference twin, he may be unable to implement his optimal decision rule and influential communication may be altogether impossible. We remark that these results would not emerge in an expected utility environment. Third, we find that there often exist influential equilibria that do not implement the optimal decision rule of S, which is not the case in the absence of ambiguity. Fourth, we show that the addition of a little ambiguity may generate influential communication that is unambiguously advantageous to S. Fifth, we consider a smooth version of our model and find that some of our key findings extend to this setting.

Keywords: cheap talk, ambiguity.

JEL classification: D81, D83.

*We thank M. Lang, D. Krähmer, D. Szalay, S. Litterscheid, F. Ketelaar, I. Deimen as well as participants of the RUD 2013 Paris conference and the Bonn microeconomics seminar for helpful comments and suggestions.

“When I use a word,” Humpty Dumpty said, in a rather scornful tone, “it means just what I choose it to mean - nothing more nor less.”. “The question is,” said Alice, “whether you can make words mean so many different things.”. (Alice in Wonderland, Lewis Carroll)

1 Introduction

Ambiguity is an integral part of many situations of advice and typically simultaneously appears in two forms that reflect the ambiguity of the very term "ambiguity". It is present on the one hand in the prior distribution of states and on the other hand in the mode of communication of the sender.

Advice often takes place under knightean uncertainty about the prior distribution of the state of the world. In a medical advice context, the distribution of particular diseases across ethnic groups may be unclear. In a financial advice context, the underlying process governing the state of the economy may be unknown.

Ambiguity also often appears in the language of the sender in the form of messages that are subject to a multiplicity of interpretations rather than simply vague. A statement is vague if it has a unique unspecific meaning that all agree on, while a statement is ambiguous if different individuals are likely to derive different precise meanings from it. Vague and ambiguous statements thus differ on two dimensions: the precision of the beliefs that they induce and the likelihood of ex post disagreement between different receivers. Ambiguous sentences abound in everyday language. A mentor asked to provide a recommendation letter may for example choose to write "I cannot recommend X enough.", which can be interpreted in two mutually contradictory ways. Necker cubes (see below) capture visually the notion of multiple interpretations. A Necker cube representation is compatible with two different configurations of a simple cube. Some individuals primarily see the one configuration, others rather see the other, while some see both immediately.

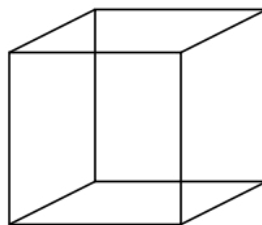

We see two starting points for research on communication and ambiguity. First, the common presence of Knightian uncertainty in situations of advice justifies examining a model of advice featuring Knightian or "subjective" uncertainty. Second, the ubiquity of ambiguous language begs for a theoretical explanation. Existing models of strategic communication, even when explicitly purporting to study ambiguous communication, analyse vagueness. (see for example Alesina and Cukierman (1990), Aragonès and Neeman (2000), Callander and Wilson (2008), Tomz and Van Houweling (2009)).

We argue that the two above mentioned aspects are naturally addressed simultaneously. Our insight is that ambiguous language arises spontaneously in a subjectively uncertain world populated by ambiguity averse agents. We examine a simple binary model of advice in which the distribution of the state of the world is subject to Knightian uncertainty, i.e. ambiguous. We characterize the set of influential equilibria and discuss how key features of these relate to common notions of ambiguous language. We briefly overview our main findings in what follows.

A first preliminary finding is that agents favour randomization for a subset of inconclusive or intermediate signal realizations. This originates in ambiguity averse agents' desire to hedge in the face of ambiguity and is a typical feature of this family of models.

We first focus on the class of equilibria that implement S 's optimal decision rule (so-called S -optimal equilibria), which is the only class featuring influential communication under no ambiguity. A first important finding is that in every S -optimal equilibrium, S randomizes between equilibrium messages that trigger strictly different beliefs and different (mixed or pure) actions by R . The randomization performed by S may furthermore be echoed by randomization on the side of R after certain messages.

We attach three comments on the randomization operated by S . First, in the classical Crawford and Sobel model, any partitional equilibrium can be reinterpreted as an equilibrium in which S mixes between messages, but such mixing only involves messages that cause identical beliefs and identical actions. The involved mixing is therefore immaterial, as opposed to the mixing that appears in the S -optimal equilibria of our model, which can in contrast not be disposed of. Second, the mixing performed by S in an S -optimal equilibrium can be reinterpreted as mixing over a set of classical partitional communication strategies, upon observation of his private signal. Third, the randomization performed by S in S -optimal equilibria differs from that arising within the "noisy

talk" model of Blume, Board and Kawamura (2007) to the extent that it is voluntary. We expand on this point in the literature review.

We add some remarks on a possible interpretation of the randomization performed by S or by R in S -optimal equilibria. We find that the two types of randomization relate to two common modes of ambiguous communication. When S mixes between messages triggering different responses, this bears some similarity to the choice of versatile formulations that might be perceived differently by different individuals, just as a Necker cube might be perceived differently by different individuals. When instead S sends a message that gives rise to randomization by R , this is somewhat equivalent to S taking an agnostic stance, abstaining from recommending a pure action and instead stating that "the optimal pure action of R depends on the prior beliefs applied". These two modes of ambiguous communication constitute two different versions of the "multiplicity of interpretations" that is the essence of ambiguous language. One could distinguish between perceptual and introspective ambiguity: While the first form of ambiguity arises in the process of perception of the language, the second arises in the process of deriving the implications of the perceived language.

Our second main finding is a technical observation that considerably simplifies our analysis of the set of S -optimal equilibria. We show that in characterizing key comparative statics of the set of S -optimal equilibria, whether regarding the effect of preference misalignment or the effect of restrictions on the message space, we may focus on so-called z -equilibria. In these, S 's communication strategy is described by three simple thresholds and associated mixing probabilities computed on the basis of the two agents' preference parameters.

Our third main finding considers the relevance of the message space cardinality for the existence of S -optimal equilibria. While it is trivial that no more than three messages are ever useful, a key question is whether two are sufficient, given that the action set is after all of cardinality two. We find that under high ambiguity, the availability of a third message is far from being inconsequential. The use of three messages is necessary to guarantee the existence of an S -optimal equilibrium if R has strongly misaligned preferences. More surprisingly, if S is restricted to using only two messages, there sometimes arises what we term a "Doppelgänger Paradox": there exists no S -optimal equilibrium even if R and S have exactly the same preferences. Furthermore, when the latter paradox arises, an S -optimal equilibrium may instead exist if R is instead moderately biased.

Our fourth main finding is that there typically now also exist equilibria featuring influential communication that do not implement the optimal decision rule of S . This is not the case in the absence of ambiguity.

Our fifth result regards the effect of the addition of a little ambiguity, starting from no ambiguity. We demonstrate that this can generate the possibility of influential communication and be unambiguously beneficial to S .

We conclude our analysis by examining a smooth version of our model. The main difference is that the optimal decision rule of agents now features mixing that varies continuously as a function of the available information. Results are otherwise very reminiscent of the Max-Min model. Equilibria feature randomization across messages as in the Max-Min model and can be interpreted as randomization over classical partitioned communication strategies. The use of more messages, as in the previous model, can be beneficial for S . As in the Max-Min model, if restricted to using only two messages, S may prefer to face a biased receiver rather than his alter ego.

Literature review Our contribution lies at the intersection on the literatures on respectively cheap talk communication and ambiguity. The first was initiated by the seminal model of Crawford and Sobel (1982). The equilibrium randomization over messages inducing different beliefs featured in our model bears a relation to the noisy communication studied in Board, Blume and Kawamura (2007). In the latter model, an emitted message may be randomly swapped with another during the transmission process. The authors show that this exogenous randomization in communication may be welfare beneficial, as it improves the truthelling incentives of the sender. If the sender, however, had access to non noisy messages, he would strictly favour these over noisy messages. The exogenously imposed randomization featured in the "noisy talk" model thus contrasts with the endogenous randomization characterizing our model. Blume and Board (2010, 2012) offer a further exploration of the concepts introduced in Blume, Board and Kawamura (2007).

Our paper also relates to the literature of ambiguity. We model ambiguity based on the Max-Min model (Gilboa (1987), Gilboa and Schmeidler (1989)) and the Smooth Ambiguity model (Klibanoff et al. (2005)), which nests the Max-Min Model as a limit case. It is well-known that no common practice on updating of ambiguity averse preferences has yet emerged. We refer to Siniscalchi (2011) as well as Hanany and Klibanoff (2007, 2009) for a discussion of this issue. Recently, ambiguity has been brought to strategic settings by a number of authors. The contributions of Azrieli

and Teper (2011), Bade (2010) as well as Riedel and Sass (2011) define general equilibrium concepts under ambiguity. A large array of papers study more specific applications to finance, tournaments or contract theory. Somewhat more related contributions include a number of studies of mechanism design under ambiguity (Bose and Renou (2011), Di Tillio et al. (2011)). The latter contributions, in applying the Revelation Principle, analyze a messaging game in the presence of ambiguity.

2 The Max-Min model

2.1 The model

The following section introduces the game G , the considered strategies as well as the equilibrium concept invoked.

There are two agents, a sender S and a receiver R . The state of the world $\omega \in \Omega = \{A, B\}$ has a subjectively uncertain distribution $\{1 - P_j(B), P_j(B)\}$, for $j \in \{l, h\}$, where for both agents, $P_h(B)$ is the maximal prior weight assigned to state B and $P_l(B)$ is the minimal prior weight assigned to state B . We assume that $P_h(B) = \frac{1}{2} + e$ and $P_l(B) = \frac{1}{2} - e$, for some $e \in (0, \frac{1}{2})$. We sometimes explicitly denote priors by $P_h^e(B)$ and $P_l^e(B)$ to mark the dependence on e . R can choose among two actions a and b .

The preferences of each agent $i \in \{S, R\}$ are described by a parameter $q_i \in (0, 1)$. Given a state and a given action, payoffs to agent $i \in \{S, R\}$ are given by $\pi_i(b, A) = -q_i$, $\pi_i(a, B) = -(1 - q_i)$, while $\pi_i(a, A) = \pi_i(b, B) = 0$. The parameter q_i thus denotes an agent's relative aversion to type I and type II errors. Defining $E(\pi_i(j) \mid I, P_k(B))$ as the expected payoff of action j for agent i given information I and prior $P_k(B)$:

$$\begin{aligned} E(\pi_i(b) \mid I, P_k(B)) &= -q_i P(A \mid I, P_k(B)) \\ E(\pi_i(a) \mid I, P_k(B)) &= -(1 - q_i) P(B \mid I, P_k(B)), \end{aligned}$$

meaning that for a given prior $P_k(B)$ and a given information set I , an ambiguity neutral agent i favours action b iff $P(B \mid I, P_k(B)) \geq q_i$ and otherwise strictly favours action a . An ambiguity neutral agent thus always strictly prefers a pure action, given his information, except in the knife-edge case where $q_i = P(B \mid I, P_k(B))$. The preference parameter q_S and q_R are public information and $q_R < q_S$.

A jury trial environment matches the basic features of this model. Jurors, whatever their exact sensibilities, agree that a guilty defendant should be convicted while an innocent defendant should be acquitted. They however differ as to their exact threshold of reasonable doubt. Letting B stand for the guilty state, our assumptions on preferences imply that S is less eager to convict than R .

Preferences given ambiguous beliefs The agent chooses the mixed action $\rho = (\rho_a, \rho_b)$ that maximizes the minimal expected payoff over all possible priors. I.e. the agent chooses the mixed action ρ_R^* s.t.

$$\rho^* = \arg \max_{\rho \in \Delta_{ab}} \min_{P_k(B) \in [P_l(B), P_h(B)]} \sum_{j \in \{a, b\}} \rho_j E(\pi_i(j) | I, P_k(B)),$$

where Δ_{ab} is the set of all distributions over the action space $\{a, b\}$. Let $P_j(B | I)$ denote the conditional probability of state B given information I , when applying prior $P_j(B)$. It is easily seen that the optimal decision rule of an agent with preference parameter q is given as follows. First, choose a for sure if $P_h(B | I) < q$. Secondly, randomize with probability $\{q, 1 - q\}$ over respectively a and b if $P_l(B | I) \leq q \leq P_h(B | I)$. Finally, choose b for sure if $q \leq P_l(B | I)$.

Information structure S receives a signal σ which is drawn from a state dependent continuous distribution $F_\omega(\sigma)$ with density function $f_\omega(\sigma)$. $F_A(\sigma)$ and $F_B(\sigma)$ are s.t. $\frac{f_B(\sigma)}{f_A(\sigma)}$ is strictly increasing in σ , thus satisfying MLRP. It follows that if $\frac{f_B(\sigma)}{f_A(\sigma)}$ is sufficiently low for low values of σ while $\frac{f_B(\sigma)}{f_A(\sigma)}$ is sufficiently large for large values of σ , there exist, for each agent $i \in \{S, R\}$, thresholds $t_i^1(q_i)$, $t_i^2(q_i) \in (l, u)$, $t_i^1(q_i) < t_i^2(q_i)$, s.t. the following is true: for $\sigma < t_i^1(q_i)$, agent i strictly favours a , for $\sigma \in (t_i^1(q_i), t_i^2(q_i))$, agent i strictly favours randomizing by choosing a with probability q_i , and for $\sigma > t_i^2(q_i)$, agent i strictly favours action b . It is immediate that $t_R^1(q_S) < t_S^1(q_S)$ and $t_R^2(q_R) < t_S^2(q_S)$ given that $q_R < q_S$.

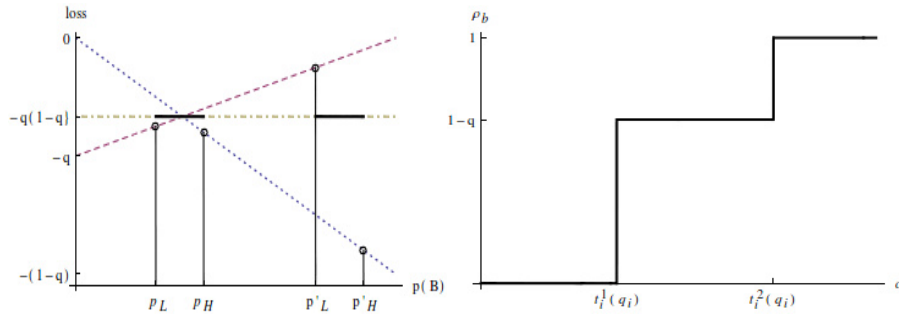

Figures 1a and 1b: the optimal decision rule in the Max-Min model.

In Figure 1.a., the decreasing (increasing) line shows the expected utility of action a (b) as a function of the prior probability of state B . The horizontal dot-dashed line shows the expected utility of the randomization policy $(q, 1 - q)$ as a function of the prior probability assigned to state B . If the interval of priors considered is (p_L, p_H) , it is clear that the Max-Min policy is the randomization policy $(q, 1 - q)$. On the other hand, if the interval of priors considered is (p'_L, p'_H) , the Max-Min policy is to always choose action b . Figure 1.b. shows the optimal decision rule of an agent with preference parameter q as a function of the received signal σ .

Communication protocol and equilibrium S can communicate costlessly with R by emitting a message $m \in M$, where M is a set of cardinality $n \geq 3$ in which individual messages are numbered m_1, \dots, m_n . A communication strategy δ_S of S specifies, for each information set I of S , a distribution over messages belonging to M .

The timing of the game G is given as follows:

0. Nature draws a state ω ,
1. Nature draws a signal according to F_ω ,
2. S issues a message,
3. R chooses an action.

A decision strategy δ_R of R specifies a distribution $(\delta_R(a, m), 1 - \delta_R(a, m))$ over actions (a, b) for each possible message in M . A Weak Perfect Bayesian equilibrium E of the game G is given by: 1) a communication strategy δ_S of S , 2) a decision strategy δ_R of R and 3) a system of beliefs satisfying the following two requirements. First, δ_S and δ_R are sequentially rational given the system of beliefs. Secondly, for each prior $\tilde{P}(B)$ in the set of possible priors and each message $m \in M$, posterior beliefs are derived by Bayes' rule whenever possible. Let the belief function $\tau(m, \tilde{P}(B))$ specify the probability assigned by R to state B upon reception of a message m , when applying the prior distribution $\tilde{P}(B)$.

Sequential rationality of δ_R implies that R chooses action a given m if and only if $\tau(m, P_h(B)) < q_R$, chooses a with probability q_R iff $\tau(m, P_l(B)) \leq q_R \leq \tau(m, P_h(B))$ and chooses action b otherwise. Let $E(\pi_S | m, \delta_R, P_k(B), I)$ denote the expected payoff of S under the prior $P_k(B)$ at information set I , if R uses the decision strategy δ_R . Sequential rationality of δ_S implies that at any information set

If the strategy δ_S specifies the distribution $\vartheta^* = (\vartheta_1^*, \dots, \vartheta_n^*)$ over messages in M , then

$$\vartheta^* = \arg \max_{\vartheta \in \Delta_M} \min_{P_k(B) \in [P_l(B), P_h(B)]} \sum_{r=1, \dots, n} \vartheta_r E(\pi_S | m_r, \delta_R, P_k(B)), \quad (1)$$

where Δ_M is the set of all distributions over M . We do not define any out of equilibrium beliefs. Indeed, by a standard argument, for any equilibrium in which only a strict subset of the messages contained in M is emitted with strictly positive probability, there exists an outcome equivalent equilibrium in which all messages in M are emitted with strictly positive probability. We say that an equilibrium is influential if there exist two different messages m and m' that are sent with strictly positive probability and s.t. $\delta_R(a, m) \neq \delta_R(a, m')$. We say that two equilibria are outcome equivalent if they induce, at every information set of S , the same distribution over actions of R . Note that two outcome equivalent equilibria may differ as to the communication strategy used by S .

2.2 Main analysis

We start by a brief characterization of the set of influential communication equilibria in the absence of ambiguity.

Remark 1 *If $e = 0$ (No ambiguity) and if there exists an equilibrium with influential communication, the following equilibrium exists. S emits m_1 if he favours a , m_2 if he favours b . R chooses action a after m_1 and action b after m_2 .*

Proof: omitted.

Equilibrium behavior in the absence of ambiguity is thus very simple. If there exists an equilibrium with influential communication, then it implements S 's optimal decision rule, which is furthermore deterministic. S simply announces truthfully his favoured action and his recommendation is followed. Note that this equilibrium only exists if R is willing to take action a after message m_1 , which requires that q_R is not excessively low.

In what follows, we perform a general analysis of the set of influential equilibria of the game, in the presence of a positive amount of ambiguity. The set of influential equilibria now consists of two separate subsets, those that implement S 's optimal decision rule and those that do not. We call the first set S -optimal equilibria (SOE) and the latter non S -optimal equilibria (NSOE).

We first state a Lemma that applies to all influential equilibria and that implies that we may restrict ourselves without loss of generality to influential equilibria in which no more than 3 messages are used with positive probability on the equilibrium path. The intuition for the result resides in the fact that the best response of R to his beliefs can only take three possible forms: a for sure, b for sure or mixing over $\{a, b\}$ with probabilities $\{q_R, 1 - q_R\}$.

Lemma 1 *For every influential equilibrium, there is an outcome equivalent equilibrium in which no more than three messages are sent with positive probability.*

Proof: See Appendix A.

We now focus on the class of S -optimal equilibria. Note first, as simple observation, that there exists no S -optimal equilibrium in which S does not randomize between equilibrium messages.

Lemma 2 *There exists no S -optimal equilibrium in which S never randomizes between messages.*

The proof of the result is immediate. We know that S , for intermediate signal realizations, favours mixing over $\{a, b\}$ with probabilities $\{q_S, 1 - q_S\}$. In a putative S -optimal equilibrium in which S would never randomize over messages, one of his equilibrium messages would have to trigger mixing by R over $\{a, b\}$ with probabilities $\{q_S, 1 - q_S\}$. Yet we know that if R mixes, he does so with probabilities $\{q_R, 1 - q_R\}$. Such an equilibrium could thus not possibly implement S 's favoured decision rule.

Exhaustively characterizing the set of S -optimal equilibria of the game is both daunting and unnecessary for our purposes. In what follows, we introduce a simple subclass of the class of S -optimal equilibria, before subsequently establishing in Proposition 1 a sense in which we may restrict ourselves to this subclass without loss of generality.

Definition 1 *z -equilibrium*

In a z -equilibrium, there are messages m_1, m_2, m_3 in M s.t. S emits m_1 if $\sigma < t_S^1(q_S)$ and m_2 if $\sigma > t_S^2(q_S)$. There is a $z \in [t_S^1(q_S), t_S^2(q_S)]$ s.t. if $\sigma \in [t_S^1(q_S), z)$, S emits m_1 with probability $\frac{q_S - q_R}{1 - q_R}$ and m_3 with probability $\frac{1 - q_S}{1 - q_R}$, while if $\sigma \in [z, t_S^2(q_S)]$, S emits m_1 with probability q_S and m_2 with probability $1 - q_S$.

In a z -equilibrium, R chooses a after m_1 and b after m_2 . After m_3 , R chooses a with probability q_R .

Z-equilibria are S-optimal equilibria that feature a simple communication strategy which is entirely described by the three thresholds $\{t_S^1(q_S), z, t_S^2(q_S)\}$ and a set of mixing probabilities. A z-equilibrium in which $z = t_S^1(q_S)$ implies the emission with positive probability of exactly two messages, while any remaining z-equilibrium implies that three messages are emitted with positive probability.

The following proposition clarifies the exact relation between the set of S-optimal equilibria and the set of z-equilibria. Proposition 1 shows that in studying the set of S-optimal equilibria, we may without loss of generality limit ourselves to the set of z-equilibria.

Proposition 1 *S-optimal equilibria and z-equilibria*

- a) *Given q_S, q_R , if there exists an S-optimal equilibrium, then there exists a z-equilibrium.*
- b) *There exists an S-optimal equilibrium in which only two messages are sent with positive probability if and only if there exists a z-equilibrium in which only two messages are sent with positive probability, i.e. if and only if the z-equilibrium given by $z = t_S^1(q_S)$ exists.*

Proof: See Appendix B for a proof of Point a). The proof of Point b) is trivial and therefore omitted.

We wish to characterize the comparative statics of the set of S-optimal equilibria. Key questions are: 1) What are the lowest and highest levels of q_R compatible with the existence of an S-optimal equilibrium and how do these thresholds vary as a function of the ambiguity level e ? 2) Are strictly more than two messages sometimes necessary to allow S to implement his optimal decision rule? I.e., are there parameter values for which an S-optimal equilibrium exists if and only if strictly more than two messages are available?

The above Proposition implies that, in seeking to characterize the key comparative statics properties of S-optimal equilibria, we may restrict ourselves to the subset of z-equilibria. Given Point a) of Proposition 1, there is a close relation between the two sets. For a given q_S , the set of values of q_R for which there exists some z-equilibrium coincides with the set of values of q_R for which there exists an S-optimal equilibrium. Point b) of Proposition 1 helps us to characterize the role of the message space cardinality by establishing that if there exists no z-equilibrium using only two messages (i.e. with $z = t_S^1(q_S)$), then there exists no S-optimal equilibrium using only two messages. Thus, if we can find parameter values for which there exists no z-equilibrium with

$z = t_S^1(q_S)$ while there exists a z -equilibrium with $z > t_S^1(q_S)$, we have shown that an S -optimal equilibrium exists if and only if strictly more than two messages are available.

Our next proposition offers a first characterization of the comparative statics of the set of S -optimal equilibria. Before stating our result, we introduce a useful condition on the distribution of signals:

$$\frac{\frac{F_B(\sigma)}{F_A(\sigma)}}{\frac{\partial(\frac{F_B(\sigma)}{F_A(\sigma)})}{\partial\sigma}} > \frac{\frac{f_B(\sigma)}{f_A(\sigma)}}{\frac{\partial(\frac{f_B(\sigma)}{f_A(\sigma)})}{\partial\sigma}}, \forall \sigma. \quad (2)$$

From now on, we assume that (2) holds. We add a Lemma regarding condition (2), showing that it is satisfied in the following two canonical cases.

Lemma 3 *a) Suppose that f_B and f_A are two normal distributions with identical variance ξ^2 and means μ_A, μ_B , with $\mu_A < \mu_B$. Then (2) is satisfied.*

b) Suppose that f_B and f_A are two linear distributions defined over the same bounded interval and that f_B increases in σ while f_A decreases in σ . Then (2) is satisfied.

Proof: See in Appendix D.

Proposition 2 Message space cardinality and S -optimal equilibria.

Given q_S , there are positive constants $e_1(q_S), e_2(q_S), e_3(q_S)$ satisfying

$$\frac{1}{2} > e_3(q_S) > e_1(q_S) > 0$$

s.t. the following is true:

i. Suppose that three messages are available. Given q_S and e , there exists $\underline{q}_R(q_S, e, 3) < q_S$ s.t. there exists an S -optimal equilibrium iff $q_R \in [\underline{q}_R(q_S, e, 3), q_S]$.

ii. Suppose that only two messages are available.

ii.a) There is a positive constant $e_3(q_S)$ s.t. if $e > e_3(q_S)$, there exists no S -optimal equilibrium for any q_R while instead if $e \leq e_3(q_S)$, there exist strictly positive thresholds $\underline{q}_R(q_S, e, 2)$ & $\bar{q}_R(q_S, e, 2)$ satisfying $\underline{q}_R(q_S, e, 2) < \bar{q}_R(q_S, e, 2) \leq q_S$ s.t. there exists an S -optimal equilibrium iff $q_R \in [\underline{q}_R(q_S, e, 2), \bar{q}_R(q_S, e, 2)]$.

ii.b) Lower bound. There is a positive constant $e_1(q_S) < e_3(q_S)$ s.t. $\underline{q}_R(q_S, e, 2) = \underline{q}_R(q_S, e, 3)$ if $e \leq e_1(q_S)$ while instead $\underline{q}_R(q_S, e, 2) > \underline{q}_R(q_S, e, 3)$ if $e \in (e_1(q_S), e_3(q_S)]$.

ii.c) Upper bound. There is a positive constant $e_2(q_S) \leq e_3(q_S)$ s.t. $\bar{q}_R(q_S, e, 2) = q_S$ if $e \leq e_2(q_S)$ while instead $\bar{q}_R(q_S, e, 2) < q_S$ for $e \in (e_2(q_S), e_3(q_S)]$.

Proof: see in Appendix C.

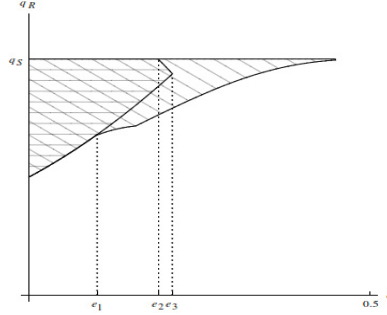

Figure 2.

Figure 2 above illustrates Proposition 2. It considers the case of $f_B(\sigma) = 2\sigma$, $f_A(\sigma) = 2 - 2\sigma$ and $q_S = .66$. The horizontally striped area indicates pairs (e, q_R) for which there exists an S -optimal equilibrium if only two messages are available. The diagonally striped area indicates pairs (e, q_R) for which there exists an S -optimal equilibrium if three messages are available.

Point i. shows that the behavior of the model is standard and simple, if three messages are available to S . When it comes to implementing the optimal decision rule of S , if no restriction is imposed on the cardinality of the message space, the conditions on q_R are in line with intuition concerning the negative impact of preference misalignment. There is a minimal receiver type $\underline{q}_R(q_S, e, 3)$ below which the S -optimal decision cannot be implemented and above which the S -optimal rule can be implemented. In the absence of any restriction on language, S can in particular always implement his optimal decision rule when facing his preference twin, i.e. his Doppelgänger.

Point ii. shows that the absence of a third message hurts S in terms of his ability to implement his optimal decision rule, whenever ambiguity is sufficiently high. Point ii.a. shows that for a given q_S and e smaller than some constant $e_3(q_S)$, there is a closed interval $[\underline{q}_R(q_S, e, 2), \bar{q}_R(q_S, e, 2)]$ of values of q_R s.t. an S -optimal equilibrium exists iff q_R belongs to this interval. If instead e is larger than the constant $e_3(q_S)$, there exists no S -optimal equilibrium if only two messages are available, whatever q_R . Point ii.b. shows that the lower bound $\underline{q}_R(q_S, e, 2)$ is strictly higher than $\underline{q}_R(q_S, e, 3)$ if e is larger than some constant $e_1(q_S) < e_3(q_S)$. Thus, if ambiguity is high enough and R has strongly misaligned preferences, the availability of a third messages is crucial in allowing S

to perfectly "manipulate" R . Point ii.c. shows an equivalent (albeit less categorical) result for the upper bound $\bar{q}_R(q_S, e, 2)$.

A salient aspect of our characterization is that for e larger than some constant $e_2(q_S) \leq e_3(q_S)$, there may exist no S -optimal equilibrium for $q_S = q_R$. We call this phenomenon "Doppelgänger Paradox".

In order to interpret our results, we now go back to the set of z -equilibria. We use the new notation $t_S^1(q_S, e), t_S^2(q_S, e)$ for the thresholds $t_S^1(q_S)$ and $t_S^2(q_S)$, thus explicitly marking the dependence of these objects on the ambiguity level e . In what follows, remember that the threshold z , in a z -equilibrium, is a priori restricted to belong to the interval $[t_S^1(q_S, e), t_S^2(q_S, e)]$.

Suppose that the level of ambiguity is high, so that that even if q_R is rather low, there is a common hedging interval $[t_S^1(q_S, e), t_R^2(q_R, e)]$ where both S and R find it optimal to randomize (though with different probabilities), i.e.

$$t_R^1(q_R, e) < t_S^1(q_S, e) < t_R^2(q_R, e) < t_S^2(q_S, e)$$

Recall that the only putative z -equilibrium profile that necessitates only two messages is defined by $z = t_S^1(q_S, e)$. It is intuitive that such an equilibrium will fail to exist if q_R is sufficiently low. Indeed, in such a putative equilibrium, R will not choose action a with probability one after message m_1 if q_R is sufficiently low.

In the above situation where the $z = t_S^1(q_S, e)$ equilibrium fails to exist, let us consider instead z -equilibria in which S makes use of 3 messages, i.e. z -equilibria with $z > t_S^1(q_S, e)$. Let us choose a z sufficiently small that S now sends m_3 only when his signal belongs to the common hedging interval $[t_S^1(q_S, e), t_R^2(q_R, e)]$, so that mixing is indeed optimal for R given m_3 . As compared to the 2-messages equilibrium considered above (defined by $z = t_S^1(q_S, e)$), the advantage is that the message m_1 is now used with a smaller probability for an interval of rather high signal realizations. In the previous equilibrium scenario given by $z = t_S^1(q_S, e)$, m_1 was used with probability q_S in the interval $[t_S^1(q_S, e), z)$ while it is now used only with probability $\frac{q_S - q_R}{1 - q_R}$ in that same interval. By using m_1 less often in this particular interval, m_1 now becomes a stronger indication of low signal realizations, so that it now may be optimal for R to choose a after m_1 . If this is so, then S now succeeds in implementing his favorite decision rule by optimally setting $z > t_S^1(q_S, e)$ rather than $z = t_S^1(q_S, e)$. This argument, in a nutshell, shows how the use of the third message m_3 can be helpful for S , when ambiguity is high and q_R is sufficiently low.

Suppose now instead that the level of ambiguity is low. Assume furthermore that q_R is very low, so that the regions where both players prefer mixing will not overlap. Here, whenever S wants to randomize, R already wants to choose b with probability one. Hence, in a z -equilibrium with $z > t_S^1(q_S, e)$, R 's reaction to m_3 must be identical to his reaction to m_2 (choose b for sure), so that using m_3 cannot be helpful. In this case, a z -equilibrium using three messages can never implement the S -optimal rule if the two-message z -equilibrium cannot. This argument, in a nutshell, shows how the availability of a third message is of no use to S , when ambiguity is low and q_R is rather low.

A further property of the set of z -equilibrium is that for given q_R, q_S and e , there often exists a continuum of such equilibria (see Proposition 8 in Appendix C). This feature originates in the fact that there are two different ways to ensure the optimal hedging behavior by R for intermediate signal realizations: either mix between m_1 and m_2 , where each of these triggers a pure action (resp a and b), or mix between m_1 and m_3 , where m_3 triggers randomization by R . Many different combinations of these two ways will ensure that R indeed acts as desired by S and thus implements the latter's optimal decision rule.

We add three remarks on the "Doppelgänger Paradox" that may arise in our model when S is restricted to using only two messages.

If $q_R = q_S$, one would expect that there exists a simple z -equilibrium given by $z = t_S^1(q_S, e)$, thus making the message space restriction inconsequential. The intuition for this would run as follows. In such a putative equilibrium, R chooses a for sure after message m_1 and b for sure after m_2 . S simply randomizes optimally between m_1 and m_2 whenever his signal belongs to the hedging interval $[t_S^1(q_S, e), t_S^2(q_S, e)]$ and otherwise chooses m_1 or m_2 . R , recognizing that his optimal decision rule coincides with that of S , should be willing to stick to the postulated equilibrium behavior, recognizing that it leads to the implementation of his own best decision rule. This intuition is however wrong, as we now explain. Under the updating rule assumed, R considers the received message as a natural signal and simply applies his own optimal (ambiguity averse) decision rule to this signal. The fact that in the z -equilibrium given by $z = t_S^1(q_S, e)$, S has already acted in a way that maximized his own (ambiguity averse) preferences is immaterial. R recognizes that if he knew what S knows, he should act according to his putative equilibrium strategy. But he does not know what S knows, but something much less precise. R does not know whether a given recommendation for a pure action was emitted at an information set where

S favours a pure action or at an information set where S favours randomization over actions. Consequently, his best action given the message sent to him does not coincide with that favoured by S . This insight indicates that beyond the misalignment of interests encoded in preference types, there remains an intrinsic difference in interests between S and R that originates in the different positions allocated to these within the game.

One might argue that a similar "Doppelgänger paradox" would arise in an expected utility framework. In the canonical Crawford and Sobel environment, a limitation on language would after all also prohibit S from implementing his first best decision rule even in the absence of any interest misalignment. This argument, though generally valid, does not apply to our very simple environment. Assume our binary environment and simply eliminate the uncertainty about priors. Suppose that the optimal decision rules of S and R would be identical to those given in our environment, i.e. take action a for low signal realizations, b for high realizations and randomize for intermediate signals. In such a setting, the above mentioned deviation incentive of an unbiased R , in a putative z -equilibrium given by $z = t_S^1(q_S, e)$, would not arise anymore. R would be satisfied to take action a after m_1 and action b after m_2 , in the knowledge that each message might have been emitted either when S favours a pure action or when he instead favours randomization. The restriction to only two messages is thus not enough to generate the result. The presence of ambiguity as well as ambiguity aversion is crucial to the emergence of the Doppelgänger paradox. A second difference w.r.t. the expected utility environment resides in the comparative statics of the two models. In an expected utility environment, an increase in R 's bias would not be helpful, if the restriction on the cardinality of the message space were maintained. This is in contrast the case in the present environment. (see Figure 2.c)

The above counterintuitive result depends crucially on the updating rule assumed on the receiver side. Following Hanany and Klibanoff (2007), one might instead let the set of priors considered and updated by R be a function of the information set at which he is located. Consider again the putative z -equilibrium given by $z = t_S^1(q_S, e)$ and assume that $q_R = q_S$. The reason why R deviates under the assumed updating rule is that for some of his priors, message m_2 implies that action a is ex post optimal (see subsection 3.1). Instead, one might assume an updating rule specifying that after message m_2 , R selectively ignores or eliminates priors leading him to favor action a , while the updating rule is otherwise identical to the one that we have assumed. Under such a modified updating rule, R would not want to deviate after m_2 and the putative equilibrium given by $z = t_S^1(q_S, e)$ would indeed exist. Such an updating rule is introduced in Hanany and Klibanoff

(2007) with the aim of reestablishing dynamically consistent behavior and appears relevant here. The idea is to let R update in a way that accounts for the fact that S has already randomized over signals in order to hedge against uncertainty, so that additional randomization is counterproductive, conditional on the available signal (which only S observes). One might similarly consider different updating rules for S with the same aim of alleviating the Doppelgänger problem, but we leave this issue aside.

We now provide a characterization of the set of non S -optimal equilibria. Recall that this set is empty in the absence of ambiguity. We introduce the decision rules D_1 and D_2 . In D_1 , action a is chosen with probability q_R if $\sigma < t_S^2(q_S)$ and with probability zero if $\sigma \geq t_S^2(q_S)$. In D_2 , action a is chosen with probability 1 if $\sigma < t_S^1(q_S)$, with probability q_S if $\sigma \in [t_S^1(q_S), t_S^2(q_S)]$ and with probability q_R if $\sigma > t_S^2(q_S)$.

Decision rules D_1 and D_2 differ as to where the deviation from the S -optimal decision rule takes place. In D_1 , the deviation is starkest for $\sigma < t_S^1(q_S)$ as R randomizes while S would want a to be taken for sure. For $\sigma \in [t_S^1(q_S), t_S^2(q_S)]$, R 's behavior also deviates from S 's favoured behaviour, although S would also favour randomizing over both actions, but with a smaller probability attached to b . Finally, for $\sigma > t_S^2(q_S)$, the implemented decision rule coincides with S 's optimal decision rule. In D_2 , the deviation from S 's optimal decision rule only occurs for $\sigma > t_S^2(q_S)$, in a way that is somewhat paradoxical, because the deviation from S 's optimal decision rule for this set of signals is wasteful for both players.

Proposition 3 Non S -optimal equilibria

- a) Any influential NSOE implements decision rule D_1 or D_2 .
- b) If there exists any NSOE implementing D_1 , then the following NSOE exists. S emits m_1 if $\sigma < t_S^2(q_S)$ and m_2 if $\sigma \geq t_S^2(q_S)$. R chooses action a with probability q_R after m_1 and b with probability one after m_2 .
- c) If there exists any NSOE implementing D_2 , then the following NSOE exists. S emits m_1 if $\sigma < t_S^1(q_S)$, m_1 with probability $\frac{q_S - q_R}{1 - q_R}$ and m_2 with remaining probability if $\sigma \in [t_S^1(q_S), t_S^2(q_S)]$ and m_2 for sure if $\sigma \geq t_S^2(q_S)$. R chooses action a for sure after m_1 and with probability q_R after m_2 .
- d) For given q_S and e , there exist positive thresholds $\underline{q}_R^1(q_S, e)$ & $\bar{q}_R^1(q_S, e)$ satisfying $\underline{q}_R^1(q_S, e) < \bar{q}_R^1(q_S, e) \leq q_S$ s.t. an NSOE implementing D_1 exists iff $q_R \in [\underline{q}_R^1(q_S, e), \bar{q}_R^1(q_S, e)]$. For e sufficiently low, $\bar{q}_R^1(q_S, e) < q_S$.

e) For given q_S and e , if there exists an NSOE implementing D_2 for a given $q_R \leq q_S$, then there exists such an equilibrium for all $q'_R \in (q_R, q_S]$. For e sufficiently low, there exists no equilibrium implementing D_2 .

Proof: See Appendix E.

When ambiguity is low, for an equilibrium implementing decision rule D_1 , existence conditions are not summarized by a lower bound $\underline{q}_R^1(q_S, e)$ on q_R s.t. for any value of q_R belonging to the interval $[\underline{q}_R^1(q_S, e), q_S]$, such an equilibrium exists. Indeed, there is also an upper bound $\bar{q}_R^1(q_S, e) < q_S$ s.t. an equilibrium implementing D_1 exists only if $q_R \leq \bar{q}_R^1(q_S, e)$. Under low ambiguity, for an NSOE implementing D_1 to exist, the preference misalignment between R and S should neither be too large nor too small.

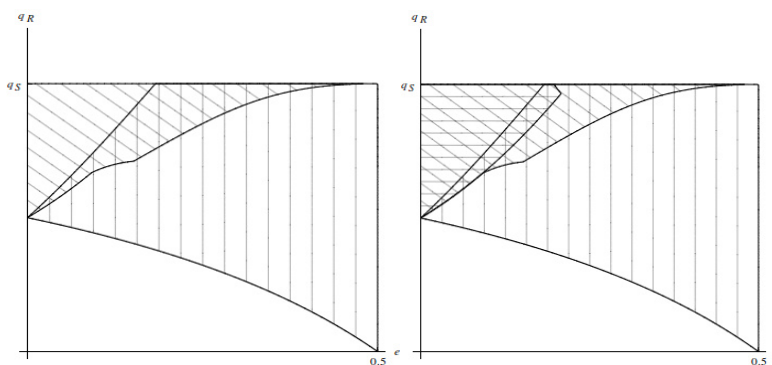

Figures 3.a and 3.b.

Figures 3.a and 3.b above consider the same parameter values as Figure 2. I.e. we assume $f_B(\sigma) = 2\sigma$, $f_A(\sigma) = 2 - 2\sigma$ and $q_S = .66$. Figure 3.a depicts, for every possible pair (e, q_R) , the complete set of decision rules that can be implemented if three messages are available. The vertically striped area indicates pairs (e, q_R) for which there exists an equilibrium implementing decision rule D_1 . The diagonally striped area indicates pairs (e, q_R) for which there exists an S -optimal equilibrium, if three messages are available. Note that for the chosen parameters, there exists no pair (e, q_R) for which there exists an equilibrium implementing decision rule D_2 . Figure 3.b simply adds the horizontally striped area, which indicates pairs (e, q_R) for which there exists an S -optimal equilibrium if only two messages are available.

Figure 3.b allows us to say more about the Doppelgänger problem that arises in our game. Here, if S faces his preference twin, there is a small interval of intermediate values of e (approximately $[\.18, \.22]$) s.t. the following is true: 1) If S is allowed to use only two messages, there

exists no equilibrium with influential communication. 2) If S is instead allowed to use three messages, there exists an equilibrium with influential communication, more specifically an S -optimal equilibrium. The above finding constitutes a clear departure from the classical expected utility environment. Consider the general class of models in which 1) the signals of S as well as the action space are one dimensional and 2) both S and R 's optimal action is monotonically increasing in S 's signal. In any such model, if the cardinality of the message space is at least two, we postulate that there always exists an equilibrium featuring influential communication if S faces his alter ego. To be sure, decreasing the cardinality of the message space of course decreases the maximal amount of achievable information transmission, but it never entirely prohibits influential communication, as long as at least two messages are available. The cardinality of the message space thus matters only in a weak sense. The classical Crawford and Sobel setup would display this property. In contrast, in Figure 4, going from a message space cardinality of three to only two renders any influential communication impossible, if ambiguity is intermediate and $q_R = q_S$. In our model, the cardinality of the message space can thus matter in a strong sense.

2.3 Adding a little ambiguity

Proposition 2 falls short of characterizing the exact comparative statics of our model wr.t. e and the next proposition provides more detail on this issue. A question that naturally arises is whether the addition of a little ambiguity can be helpful for S or R . We first show that adding a little ambiguity in the environment is not helpful, in so far as S 's ability to implement his optimal decision rule is concerned, whether or not he is restricted to only two messages. We secondly show that on the other hand, the addition of a little ambiguity may allow for the establishment of influential communication through the emergence of an equilibrium implementing decision rule D_1 . Figure 4 illustrates our findings.

Proposition 4 Adding ambiguity (I)

- i.a. S-optimal equilibria (2 or 3 messages). For any $e \leq e_1(q_S)$, $q_R(q_S, e, 3)$ is weakly increasing in e .*
- i.b. S-optimal equilibria (2 messages). For any $e \leq e_3(q_S)$, $q_R(q_S, e, 2)$ is weakly increasing in e and $\bar{q}_R(q_S, e, 2)$ is weakly decreasing in e .*
- ii. Equilibria implementing decision rule D_1 . For any e , $q_R^1(q_S, e)$ is weakly decreasing in e and $\bar{q}_R^1(q_S, e)$ is weakly increasing in e .*

Proof: See in Appendix F.

We furthermore compare babbling under no-ambiguity to the D_1 equilibrium scenario arising under small ambiguity. We do so by comparing the expected payoff obtained by agent i in the babbling equilibrium under no-ambiguity to the expected payoff obtained by i in the D_1 equilibrium under a given ambiguity level e , under his most adverse prior. In order to prove that agent i unilaterally favours the second scenario, we thus simply need to establish that for each $j \in \{l, h\}$ and $i \in \{S, R\}$, given e

$$\underbrace{-(1 - P_j^e(B)) [F_A(t_S^2(e)(1 - q_R) + (1 - F_A(t_S^2(e))))] q_i - P_j^e(B) F_B(t_S^2(e)) q_R (1 - q_i)}_{\text{payoff of } i \text{ in equilibrium } D_1 \text{ under prior } P_j^e(B)} > \underbrace{-\frac{1}{2} \min \{q_i, 1 - q_i\}}_{\text{payoff of } i \text{ if } e=0 \text{ (babbling)}}. \quad (3)$$

Proposition 5 Adding Ambiguity (II)

Assume that $q_S < \frac{1}{2}$. There exists $e^* > 0$ s.t. for any $e \in (0, e^*)$, there is some $\underline{q}_R^1(q_S, e) < \underline{q}_R(q_S, 0, 3)$ s.t. for $q_R \in [\underline{q}_R^1(q_S, e), \underline{q}_R(q_S, 0, 3)]$ the two following statements are simultaneously true:

- a) There exists no S -optimal equilibrium while there exists an equilibrium implementing D_1 .
- b) In an equilibrium implementing D_1 , S obtains an expected utility that is strictly larger than his expected utility in the babbling equilibrium for $e = 0$, for any prior $P_j(B) \in [P_l^e(B), P_h^e(B)]$. In other words, (3) holds for $i = S, \forall j \in \{l, h\}$.

Proof: See Appendix F.

Our proposition shows that for e small enough and q_R sufficiently close to $\underline{q}_R(q_S, 0, 3)$, the addition of some ambiguity indeed not only generates the possibility of influential communication but also delivers an unambiguous increase in utility for S . For R , this conclusion does not apply: he may well loose, under both priors, from the transition to positive ambiguity and influential communication. Figure 4 below illustrates the proposition. The diagonally striped area indicates parameters for which there exists an equilibrium implementing the S -optimal decision rule. The vertically striped area denotes parameter values for which decision rule D_1 is implementable. The plain grey area denotes parameters for which the addition of ambiguity generates the possibility of influential communication which furthermore unambiguously improves the payoff of S .

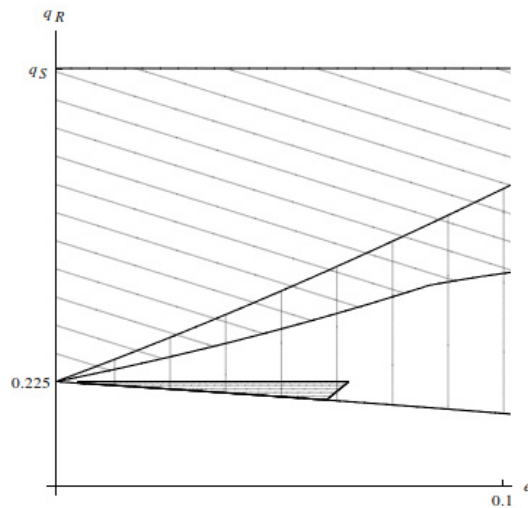

Figure 4: adding a little ambiguity.

2.4 Some remarks on z -equilibria

Given the centrality of z -equilibria to our analysis, we close our analysis of the Max-Min model with some technical as well as more interpretative remarks concerning the set of z -equilibria.

We first comment on technical aspects of z -equilibria, relating these to existing results in the cheap talk literature. A main feature of z -equilibria is the randomization undertaken by S between messages that trigger strictly different beliefs and different (mixed or pure) actions by R . This feature originates in S 's desire to hedge for intermediate signal realizations. Though in the classical Crawford and Sobel model, any equilibrium can in fact be reinterpreted as an equilibrium in which S mixes between messages, such mixing only involves messages that cause identical beliefs and identical actions. The mixing that appears in the Crawford and Sobel model is thus in a sense immaterial, while this is not the case in a z -equilibrium. Note that S 's communication strategy in a z -equilibrium can be reinterpreted as mixing by S over a set of classical partitional communication strategies, after he has received his signal. Let

$$\{l_0 = 0, (m_1), l_1, (m_2), l_2, \dots, l_{n-1}, (m_n), l_n = 1\}$$

denote a partitional communication strategy defined by a set of thresholds $\{l_1 = 0, \dots, l_n = 1\}$ such that S sends message m_i for sure between thresholds l_{i-1} and l_i . Define the following four

partitioned strategies.

$$\begin{aligned}
\alpha_1 & : \{0, (m_1), z, (m_2), 1\}, \\
\alpha_2 & : \{0, (m_1), t_S^2(q_S), (m_2), 1\}, \\
\alpha_3 & : \{0, (m_1), t_S^1(q_S), (m_3), z, (m_2), 1\}, \\
\alpha_4 & : \{0, (m_1), t_S^1(q_S), (m_3), z, (m_1), t_S^2(q_S), (m_2), 1\}.
\end{aligned}$$

Consider for example a z -equilibrium in which $z \in (t_S^1(q_S), t_S^2(q_S))$. The strategy of S is equivalent to S randomizing, after receiving his signal, over the partitioned communication strategies $\alpha_1, \alpha_2, \alpha_3$ and α_4 with respective probabilities $\left(\frac{q_S - q_R}{1 - q_R}\right) (1 - q_S)$, $\left(\frac{q_S - q_R}{1 - q_R}\right) q_S$, $\left(\frac{1 - q_S}{1 - q_R}\right) (1 - q_S)$ and $\left(\frac{1 - q_S}{1 - q_R}\right) q_S$.

As a final remark on the randomization performed by S , note that in contrast to the "noisy talk" model of Blume, Board and Kawamura (2007), randomization is desired by S here, while in the latter a sender would avoid it if he could. We close our discussion of randomization with a comment on the randomization performed by R . While this is also a new feature wr.t. to the classical Crawford and Sobel model, it follows immediately from the desire to hedge that comes with ambiguity aversion.

Another interesting feature of z -equilibria is that these typically feature three equilibrium messages although the action space only contains two pure actions. This originates in two features of the game. First, given ambiguity aversion, agents' optimal decision rules involve three types of behavior, either a or b or mixing. Secondly, this is a common value model. S and R 's optimal actions are similar for many signal realizations. They both favour a when the signal is very low, b when it is very high, and hedging when the signal is intermediate. Being able to convey whether the signal is low, high, or instead intermediate, can thus naturally be helpful.

We now relate z -equilibria to common notions of ambiguous language. We first introduce the concept of Necker messages.

Definition 2 *Necker messages*

Let \tilde{M} be a set of messages in which, for every distribution $p = (p_1, \dots, p_n)$ defined over M and every $p_0 \in [0, 1]$, there exists a message $\tilde{m}(p_0, p)$ s.t. if $\tilde{m}(p_0, p)$ is sent, R observes m_i with probability $(1 - p_0)p_i$, $\forall i \in \{1, \dots, n\}$, while he observes $\tilde{m}(p_0, p)$ with probability p_0 . Any element of \tilde{M} is a Necker message and we call \tilde{M} the Necker set.

A Necker message is thus undetectable by R if $p_0 = 0$, in the sense that it always appears to R in the form of some standard message belonging to the standard message set M . In contrast, if $p_0 > 0$, the Necker message is detected, i.e. recognized as such, with a strictly positive probability.

Two different aspects of z -equilibria relate to our definition of ambiguity. The first form of ambiguity featured in a z -equilibrium is of a semantic nature. In a given z -equilibrium where $z > t_S^1(q_S)$, m_3 may be interpreted as "whether a or b is optimal for you depends on which prior beliefs you apply". The meaning of message m_3 is thus ambiguous or agnostic to the extent that the different priors that R may make use of correspond to different interpretations or implications of m_3 . The second form of ambiguity featured in a z -equilibrium is of a perceptual nature. The randomization over messages appearing in z -equilibria can be interpreted as the emission of versatile statements, i.e. statements that may be perceived differently by different persons.

We now bring this abstract description to a concrete trial jury setting featuring messages or sentences whose literal meaning matches the Bayesian meaning that they come to endorse in an equilibrium of the game. A defendant may be innocent (A) or guilty (B) and may be acquitted (a) or convicted (b). Now, suppose that three standard messages or sentences τ_1, τ_2, τ_3 are available to S :

τ_1 : "I think that she is not guilty"

τ_2 : "I think that she is guilty."

τ_3 : "I do not have enough information to recommend the one or the other decision"

Suppose furthermore that the Necker message or sentence τ_4 is available to S :

τ_4 : "I do not think that she is guilty".

When received by R , τ_4 is mistaken for τ_1 with probability q_S and mistaken for τ_3 with probability $1 - q_S$. Note that τ_4 is an undetectable Necker message. Many people would consider τ_1 ("I think she is not guilty") and τ_4 ("I do not think she is guilty") as literally synonymous. However, some people would rather consider τ_3 ("I do not have enough information to recommend the one or the other decision") and τ_4 as literally synonymous. In this latter literal interpretation of τ_4 , S simply denies being fully convinced that conviction is the right course of action.

Now, a z -equilibrium in which $z = t_S^2$ would correspond to the following equilibrium in our trial jury game. S sends τ_1 (i.e. says "I think she is not guilty") if $\sigma < t_S^1(q_S)$ and sends τ_2 (i.e.

says "I think she is guilty") if $\sigma > t_S^2(q_S)$. Finally, if $\sigma \in [t_S^1(q_S), t_S^2(q_S)]$, S sends τ_4 (i.e. says "I do not think she is guilty") which is heard/perceived by R as τ_1 ("I think she is not guilty") with probability q_S and heard as τ_3 ("I do not have enough information to recommend the one or the other decision") with probability $1 - q_S$. After hearing τ_1 (τ_2), R chooses a (b) with probability 1 while after hearing τ_3 , R chooses a with probability q_R .

For the skeptical reader who believes that Necker messages should always have a positive probability of being detected, note that we can accommodate this within the framework of this example. Suppose thus that the Necker sentence τ_4 is actually detected with a small probability $\varepsilon > 0$, while if undetected it is mistaken for τ_1 with probability $\left(\frac{q_S - q_R}{(1-\varepsilon)(1-q_R)}\right)$ and mistaken for τ_3 with probability $\left(1 - \frac{q_S - q_R}{(1-q_R)(1-\varepsilon)}\right)$. Now, a z -equilibrium in which $z = t_S^2$ would involve the same communication strategy as described in the previous paragraph. In such a scenario, if R hears either τ_3 or τ_4 , he reacts identically: Since τ_3 can be heard if and only if the Necker message τ_4 has been sent, τ_3 necessarily triggers the same beliefs as τ_4 . After hearing τ_1 (τ_2), R chooses a (b) with probability 1 while after hearing τ_3 or τ_4 , R chooses a with probability q_R .

It is immediate that one could provide the same sort of interpretation for other z -equilibria with $z < t_S^2$. When the degenerate z -equilibrium with $z = t_S^1$ exists, for example, it is immediate that there exists an equilibrium where S uses an undetectable Necker message whenever $\sigma \in [t_S^1(q_S), t_S^2(q_S)]$.

3 The Smooth Ambiguity model

3.1 The model

We now analyze the Smooth Ambiguity version of the statistical decision model.

Prior beliefs The state of the world $\omega \in \Omega = \{A, B\}$ has an ambiguous prior distribution $\{1 - P_j(B), P_j(B)\}$, for $j \in \{h, l\}$. Two prior distributions $P_h(B)$ and $P_l(B)$ are considered possible, where $P_h(B) > P_l(B)$. The two priors $P_h(B)$ and $P_l(B)$ constitute the first order beliefs of agents. Agents share second order beliefs μ_h and μ_l , where μ_j denotes the probability attached to prior $P_j(B)$.

Belief updating Given information I , agent i simultaneously updates his first and second order beliefs. He updates first order beliefs by generating a posterior distribution for each prior

distribution (so-called prior by prior updating). He updates his second order beliefs by updating his distribution over priors. Let $P_j(B|I)$ denote the updated prior $P_j(B)$ given information I . Let $\hat{\mu}_j(I)$ denote the updated weight μ_j attached to prior $P_j(B)$ given I . Now, given information I , the following holds:

$$\frac{P_j(B|I)}{1 - P_j(B|I)} = \frac{P_j(B)}{1 - P_j(B)} \frac{P(I|B)}{P(I|A)}$$

and

$$\frac{\hat{\mu}_j(I)}{1 - \hat{\mu}_j(I)} = \frac{\mu_j}{1 - \mu_j} \frac{P_l(B)}{P_h(B)} \frac{\left(\frac{P(I|B)}{P(I|A)}\right) + (1 - P_l(B))}{\left(\frac{P(I|B)}{P(I|A)}\right) + (1 - P_h(B))}$$

It follows that only four statistics, namely the likelihood ratio $\frac{P(I|B)}{P(I|A)}$, $P_h(B)$, $P_l(B)$ and μ_h , are sufficient to compute $P_h(B|I)$, $P_l(B|I)$ and $\hat{\mu}_h(I)$, given prior I .

Preferences given ambiguous beliefs Payoffs given state and action are defined as in our previous section on the Max-Min model. Suppose beliefs are given by $P_h(B)$, $P_l(B)$ and μ_h . Suppose that the agent plays a mixed strategy according to which he chooses action b with probability β and action a with remaining probability. Then, his corresponding loss is given by the following expression:

$$\begin{aligned} & \sum_{j \in \{l, h\}} \mu_j \phi(E(\pi_i | \beta, P_j(B))) \\ &= \sum_{j \in \{l, h\}} \mu_j \phi(-(1 - P_j(B))\beta q_i - P_j(B)(1 - \beta)(1 - q_i)), \end{aligned}$$

where $\phi(u)$ is a concave function of u defined on the interval $[-1, 0]$.

For every agent i , given event η and beliefs given by $P_h(B)$, $P_l(B)$ and μ_h , let $\beta_i\left(\frac{P(\eta|B)}{P(\eta|A)}, q_i\right)$ denote the probability with which i chooses action b when applying his optimal decision rule. For notational simplicity, we sometimes abusively write $\beta_i(\eta, q_i)$. We focus on environments, as given by a choice of ϕ , a signal structure and a value of q_s , that satisfy the following: For every $i \in \{S, R\}$, there are thresholds $Q_1(q_i) > 0$ and $Q_2(q_i) > 0$ s.t.

$$\begin{aligned} \beta_i\left(\frac{P(\eta|B)}{P(\eta|A)}, q_i\right) &= 0 \text{ if } \frac{P(\eta|B)}{P(\eta|A)} < Q_1(q_i), \\ \beta_i\left(\frac{P(\eta|B)}{P(\eta|A)}, q_i\right) &\in (0, 1) \frac{\partial \beta_i\left(\frac{P(\eta|B)}{P(\eta|A)}, q_i\right)}{\partial \left(\frac{P(\eta|B)}{P(\eta|A)}\right)} > 0 \text{ if } \frac{P(\eta|B)}{P(\eta|A)} \in [Q_1(q_i), Q_2(q_i)], \\ \beta_i\left(\frac{P(\eta|B)}{P(\eta|A)}, q_i\right) &= 1 \text{ if } \frac{P(\eta|B)}{P(\eta|A)} > Q_2(q_i). \end{aligned}$$

In what follows, we assume that the conditional distributions F_A and F_B are defined over the interval $[0, 1]$ and that the information structure is s.t. $\beta_i \left(\frac{P(\sigma=0|B)}{P(\sigma=0|A)}, q_i \right) = 0$ and $\beta_i \left(\frac{P(\sigma=1|B)}{P(\sigma=1|A)}, q_i \right) = 1$, for $i \in \{S, R\}$.

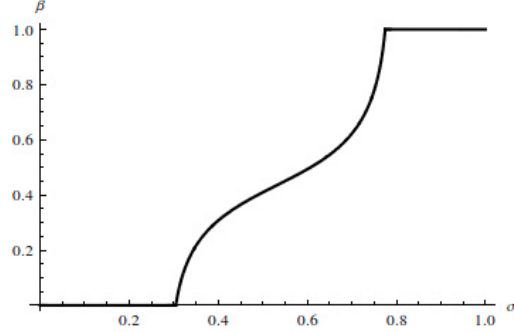

Figure 5: the optimal decision rule in the smooth ambiguity model.

Figure 5 shows a typical example of the optimal decision rule of an agent with preference parameter q as a function of the received signal σ . Notice the smooth change in the optimal randomization policy as a function of the signal, as opposed to the Max-Min case.

Note that as ambiguity aversion tends to infinity, the model converges to the Max-Min model while if ambiguity aversion tends to zero, the model tends to the expected utility model.

Communication protocol and equilibrium S can communicate costlessly with R by emitting a message $m \in M$, where $M = \{m_1, \dots, m_N\}$, for some finite $N \geq 3$. The timing of the game G is given as in the previous section on the Max-Min model. Sequential rationality of δ_R implies that R simply follows the optimal policy $\beta_R \left(\frac{P(m|B)}{P(m|A)}, q_R \right)$ given a likelihood ratio attached to message m , given beliefs derived by Bayesian prior by prior updating. Clearly, if an equilibrium is s.t. S induces his optimal randomization at every information set, then S has no incentive to deviate from his equilibrium strategy. Beliefs of R in a putative equilibrium, are formed by the application of prior by prior updating, assuming that S uses his equilibrium communication strategy.

3.2 Analysis

In what follows, we focus on a class of equilibria that implements S 's optimal decision rule. A monotone partitional communication strategy of S is described by a set of N thresholds as well

as a set of mixing functions of S , one mixing function for each interval of thresholds. Formally, a monotone N -partitions equilibrium is described by the following sender and receiver strategies.

Definition 3 Monotone N -Partitions equilibrium

Sender Communication Strategy There are N thresholds $0 = t_0^N < t_1^N < \dots < t_{N-1}^N < t_N^N = 1$. Thresholds t_1^N and t_{N-1}^N satisfy:

$$\begin{aligned} t_1^N &= \max_{\sigma \in [0,1], \beta_S(\sigma, q_S)=0} \sigma, \\ t_{N-1}^N &= \min_{\sigma \in [0,1], \beta_S(\sigma, q_S)=1} \sigma. \end{aligned}$$

Let the mixing function $\rho_{i,i+1}^N(m_j, \sigma)$ denote the probability with which S sends message m_j given that $\sigma \in [t_i^N, t_{i+1}^N]$. We have

$$\begin{aligned} \rho_{0,1}^N(m_1, \sigma) &= 1 \text{ if } \sigma \in [0, t_1^N], \\ \rho_{N-1,N}^N(m_{N-1}, \sigma) &= 1 \text{ if } \sigma \in [t_{N-1}^N, t_N^N], \\ \rho_{i,i+1}^N(m_i, \sigma) + \rho_{i,i+1}^N(m_{i+1}, \sigma) &= 1, \forall i \in \{1, \dots, N-2\}. \end{aligned}$$

For every $i \in \{1, \dots, N-1\}$ and every $\sigma \in [t_i^N, t_{i+1}^N]$,

$$\beta_S(t_i^N, q_S) = \beta_R(m_i, q_R)$$

and

$$\rho_{i,i+1}^N(m_i, \sigma) \beta_R(m_i, q_R) + \rho_{i,i+1}^N(m_{i+1}, \sigma) \beta_R(m_{i+1}, q_R) = \beta_S(\sigma, q_S).$$

Receiver Strategy For every message m_i , R best responds by choosing his optimal mix over actions, given updated beliefs. For any message $m_i \in \{m_2, \dots, m_{N-2}\}$,

$$\beta_R\left(\frac{P(m_i | B)}{P(m_i | A)}, q_R\right) \in (0, 1).$$

Also,

$$\beta_R\left(\frac{P(m_1 | B)}{P(m_1 | A)}, q_R\right) = 0 \text{ and } \beta_R\left(\frac{P(m_{N-1} | B)}{P(m_{N-1} | A)}, q_R\right) = 1.$$

We add a few comments on our definition. Note that for $\sigma \in [t_i^N, t_{i+1}^N]$, only messages m_i and m_{i+1} are sent by S with positive probability. Note also that the definition of the communication strategy of S implies that for every $i \in \{1, \dots, N-2\}$:

$$\rho_{i,i+1}^N(m_i, \sigma) = \frac{\beta_S(t_{i+1}^N, q_S) - \beta_S(\sigma, q_S)}{\beta_S(t_{i+1}^N, q_S) - \beta_S(t_i^N, q_S)} \quad (4)$$

and

$$\frac{P(m_i|B)}{P(m_i|A)} = \frac{\int_{t_{i-1}^N}^{t_i^N} \rho_{i,i+1}^N(m_i, \sigma) f_B(\sigma) d\sigma + \int_{t_i^N}^{t_{i+1}^N} \rho_{i,i+1}^N(m_{i+1}, \sigma) f_B(\sigma) d\sigma}{\int_{t_{i-1}^N}^{t_i^N} \rho_{i,i+1}^N(m_i, \sigma) f_A(\sigma) d\sigma + \int_{t_i^N}^{t_{i+1}^N} \rho_{i,i+1}^N(m_{i+1}, \sigma) f_A(\sigma) d\sigma}.$$

Note by the way that (4), given our assumptions on S 's communication strategy, is equivalent to

$$\rho_{i,i+1}^N(m_{i+1}, \sigma) = \frac{\beta_S(\sigma, q_S) - \beta_S(t_i^N, q_S)}{\beta_S(t_{i+1}^N, q_S) - \beta_S(t_i^N, q_S)}.$$

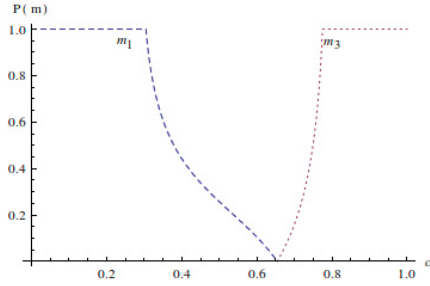

Figure 6: a 4-partitional equilibrium.

Figure 6 above assumes constant relative ambiguity aversion with ambiguity aversion parameter $\alpha = 15$ and considers the information structure given by $f_B(\sigma) = 2\sigma$, $f_A(\sigma) = 2 - 2\sigma$. Furthermore, $q_S = .55$, $\mu_h = \frac{1}{2}$, $e = \frac{1}{4}$. The figure represents a putative monotone 4-partitional equilibrium. S sends m_1 for sure in the first partition interval of signal values, starting from the left. In the second interval, S sends m_1 with the probability indicated by the drawn probability function, and otherwise sends m_2 . In the third interval, S emits m_3 with the probability indicated by the drawn probability function and otherwise sends m_2 . In the fourth interval, S emits m_3 for sure.

In what follows, we focus on two special cases of monotone partitional equilibria given by respectively 3- and 4-partitions equilibria. Note that only a unique set of thresholds given by

$$\left\{ t_0^3 = 0, t_1^3 = \max_{\sigma \in [0,1], \beta_S(\sigma, q_S)=0} \sigma, t_2^3 = \min_{\sigma \in [0,1], \beta_S(\sigma, q_S)=1} \sigma, t_3^3 = 1 \right\} \quad (5)$$

may constitute a monotone 3-partitions equilibrium. On the other hand, in a monotone 4-partitions equilibrium, only the values of thresholds $t_0^4, t_1^4, t_3^4, t_4^4$ are fixed a priori.

We start with a preliminary result (Lemma 4) showing that there exists an S -optimal equilibrium in which only two messages are used if and only if the monotone 3-partitions equilibrium

exists. Proposition 6 provides a complete characterization of pairs (q_S, q_R) for which the monotone 3-partitions equilibrium exists. Proposition 7 shows that the set of pairs (q_S, q_R) for which there exists a monotone 4-partitions equilibrium is a weak superset of the set of pairs for which there exists a monotone 3-partitions equilibrium. The proposition identifies conditions such that the former set is indeed a strict superset of the latter. When this is the case, an implication is that more complex language, i.e. the use of more messages, is helpful in allowing S to implement his optimal decision rule. Denote, in what follows, by $\frac{P(m_i|B, E_3)}{P(m_i|A, E_3)}$ the likelihood ratio implied by message m_i in the unique monotone 3-partitions equilibrium E_3 .

Lemma 4 *There exists an S -optimal equilibrium in which only two messages are used if and only if the monotone 3-partitions equilibrium exists.*

Proof: Trivial and therefore omitted.

Proposition 6 Monotone 3-Partitions equilibria.

a. If q_S is s.t.

$$\frac{P(m_1|B, E_3)}{P(m_1|A, E_3)} < Q_1(q_S), \quad (6)$$

then there exist $\underline{q}_R^3(q_S) < q_S$ and $\bar{q}_R^3(q_S) \leq q_S$, with $\underline{q}_R^3(q_S) < \bar{q}_R^3(q_S)$, s.t. the monotone 3-partitions equilibrium exists iff $q_R \in [\underline{q}_R^3(q_S), \bar{q}_R^3(q_S)]$. If (6) is not satisfied, there exists no q_R s.t. the monotone 3-partitions equilibrium exists. Furthermore, $\underline{q}_R^3(q_S)$ is s.t.

$$\frac{P(m_1|B, E_3)}{P(m_1|A, E_3)} = Q_1(\underline{q}_R^3(q_S))$$

b. If q_S is s.t.

$$Q_2(q_S) \leq \frac{P(m_2|B, E_3)}{P(m_2|A, E_3)}, \quad (7)$$

then $\bar{q}_R^3(q_S) = q_S$ while otherwise $\bar{q}_R^3(q_S) < q_S$.

Proof: See Appendix G.

Part a. provides conditions on q_S such that there exists a non empty interval of values of q_R for which the monotone 3-partitions equilibrium exists. Part b., on the other hand, provides a further condition on q_S such that for any value of q_R above a given lower bound and below q_S , the monotone 3-partitions equilibrium exists. In other words, if S is forced to use only two messages,

it may be the case (if 7 does not hold) that S favours facing a misaligned receiver rather than his alter ego. This replicates the result obtained in the Max-Min model.

Our next proposition considers values of q_S for which, for a given corresponding interval of values of q_R , the monotone 3-partitions equilibrium exists. This appears in condition (8) below, which simply repeats condition (6). Note that condition (8) exclusively depends on the value of q_S . Denote, in what follows, by $\frac{P(m_i|B,E_4,\tilde{t}_2^4)}{P(m_i|A,E_4,\tilde{t}_2^4)}$ the likelihood ratio implied by message m_i in a given monotone 4-partitions equilibrium E_4 , when t_2^4 takes the value \tilde{t}_2^4 .

Proposition 7 Monotone 4-Partitions equilibria.

a. If q_S is s.t.

$$\frac{P(m_1|B,E_3)}{P(m_1|A,E_3)} < Q_1(q_S), \quad (8)$$

there exist $\underline{q}_R^4(q_S) \leq \underline{q}_R^3(q_S)$ and $\bar{q}_R^4(q_S) \geq \bar{q}_R^3(q_S)$ s.t. a monotone 4-partitions equilibrium exists iff $q_R \in [\underline{q}_R^4(q_S), \bar{q}_R^4(q_S)]$.

b. If q_S is s.t.

$$\frac{P(m_2|B,E_3)}{P(m_2|A,E_3)} < Q_2(q_S), \quad (9)$$

so that $\bar{q}_R^3(q_S) < q_S$, then $\bar{q}_R^4(q_S) > \bar{q}_R^3(q_S)$. Otherwise $\bar{q}_R^4(q_S) = \bar{q}_R^3(q_S) = q_S$.

c. If there exists $t_2^4 \in [t_1^4, t_3^4]$ s.t.

$$\beta_R \left(\frac{P(m_2|B,E_4,t_2^4)}{P(m_2|A,E_4,t_2^4)}, \underline{q}_R^3(q_S) \right) = \beta_S \left(\frac{f_B(t_2^4)}{f_A(t_2^4)}, q_S \right), \quad (10)$$

then $\underline{q}_R^4(q_S) < \underline{q}_R^3(q_S)$. Otherwise $\underline{q}_R^4(q_S) = \underline{q}_R^3(q_S)$.

Proof: See Appendix H.

Point a. shows that if, for a given value of q_S , there exists an interval of values of q_R for which the monotone 3-partitions equilibrium exists, then there also exists an interval of values of q_R for which a monotone 4-partitions equilibrium exists. Furthermore, this interval is a weak superset of the interval of values of q_R for which the monotone 3-partitions equilibrium exists. Now, points b. and c. establish circumstances under which, for the considered values of q_S , the interval of values of q_R compatible with the existence of a monotone 4-partitions equilibrium is a strict superset of the interval of values compatible with the existence of the monotone 3-partitions equilibrium. Point b. compares the upper bound $\bar{q}_R^4(q_S)$ with the upper bound $\bar{q}_R^3(q_S)$. It has the following

interpretation: If S , conditional on being forced to use a monotone 3-partitional communication strategy, favours facing a misaligned receiver rather than his alter ego, then $\bar{q}_R^4(q_S) > \bar{q}_R^3(q_S)$. Point c. compares the lower bound $\underline{q}_R^4(q_S)$ with the lower bound $\underline{q}_R^3(q_S)$. Here, the idea is that by using 3 rather than 2 messages, S manages to restrict his use of the message m_1 to low signal realizations and thus improves the capacity of message m_1 to persuade R to take action a .

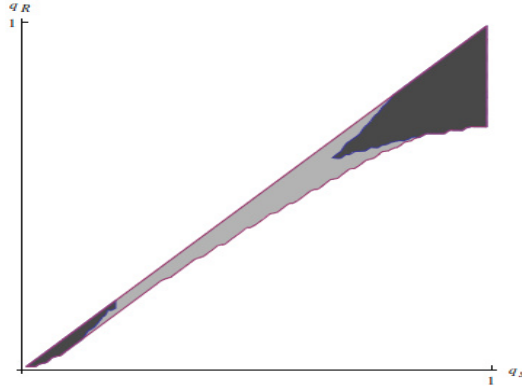

Figure 7: 3- and 4-partitions equilibria.

Figure 7 above assumes constant relative ambiguity aversion with ambiguity aversion parameter $\alpha = 15$ and considers the information structure given by $f_B(\sigma) = 2\sigma$, $f_A(\sigma) = 2 - 2\sigma$. Also, $\mu_h = \frac{1}{2}$, $e = \frac{1}{4}$. The black region identifies all possible pairs (q_S, q_R) for which there exists a monotone 3-partitions equilibrium. The union of the black and the shaded regions identifies all possible pairs (q_S, q_R) for which there exists a monotone 4-partitions equilibrium. Values of q_S may be divided into three different subsets. For values belonging to the first subset, which corresponds to extreme values of q_S , $\underline{q}_R^4(q_S) = \underline{q}_R^3(q_S)$ and $\bar{q}_R^4(q_S) = \bar{q}_R^3(q_S)$. In other words, allowing for four partitions instead of three does not help implementing S 's optimal decision rule. For values belonging to the second set, either $\underline{q}_R^4(q_S) < \underline{q}_R^3(q_S)$ or $\bar{q}_R^4(q_S) > \bar{q}_R^3(q_S)$ or both. In this case, allowing for four partitions instead of three may help implementing S 's optimal decision rule. This corresponds to the characterization given in Proposition 7. Finally, for values belonging to the third set, which corresponds to central values of q_S , there never exists a monotone 3-partitions equilibrium while there exists a monotone 4-partitions equilibrium if q_R belongs to the right interval $[\underline{q}_R^4(q_S), \bar{q}_R^4(q_S)]$, with $\underline{q}_R^4(q_S) < \bar{q}_R^4(q_S)$. Note that this final set of values of q_S is not considered in Proposition 7, i.e. this feature does not correspond to any of our theoretical results.

Note that we do not know whether there may exist monotone N -partitions equilibria featuring $N > 4$ whenever there exists no monotone 4-partitions equilibria. We conjecture that this may be the case, and that increasing the number of partitions generally helps S implement his optimal decision rule, up to some upper bound \bar{N} .

We add a note on a different result that can be shown. If S faces his preference twin, there exists a communication strategy making use of a *finite* number of messages that implements the optimal decision rule of S .

4 Conclusion

Our analysis shows that ambiguous modes of communication arise naturally when communication takes place among agents facing subjective uncertainty. We identify two modes of ambiguous communication, respectively versatile and agnostic communication. For intermediate signal values that generate a desire to hedge, these two modes of communication correspond to two different ways of allocating the randomization task among agents. From a formal perspective, the key new feature of equilibria, in both models that we examine, is that S often randomizes between messages that trigger different actions by R . Besides this key insight, we have established a set of properties of the simple binary cheap talk model within an ambiguous environment. These properties relate to the comparative statics effect of interest misalignment, language complexity as well ambiguity itself.

5 Appendix A: Proof of Lemma 1

Step 1 In a given influential equilibrium E , equilibrium messages can be gathered in three categories. Those that lead to action a being taken by R , those that lead to hedging with probabilities $(q, 1 - q)$ and those that lead to action b being chosen by R . Call these sets C_a , C_h and C_b .

Step 2 Construct an equilibrium \tilde{E} , in which S now sends a unique message m_a when he would have sent a message belonging to C_a in equilibrium E , sends a unique message m_h when he would have sent a message belonging to C_h in equilibrium E , and sends unique message m_b when he would have sent a message belonging to C_b in equilibrium E . Given that the equilibrium E exists, it is clear that R , in \tilde{E} , will weakly prefer a after m_a , hedging after m_h and b after m_b . Now, it is clear that if R follows this decision rule, S has no incentive to deviate in the equilibrium \tilde{E} .

Step 3 It follows that any influential equilibrium where strictly more than three messages are sent with positive probability, there exists an outcome equivalent influential equilibrium in which no more than three messages are used. ■

6 Appendix B: Proof of Proposition 1

6.1 Point a)

Step 1 A given z -equilibrium determines the Bayesian probabilities $P_j(B | m_1, z)$ and $P_j(B | m_3, z)$, where the subscript j indicates that we apply the prior $P_j(B)$.

Step 2 In what follows, we abusively abandon the reference to q_S and denote $t_S^1(q_S), t_S^2(q_S)$ as t_S^1, t_S^2 . Now, consider a putative S -optimal equilibrium featuring a communication strategy δ_S that is not a z -communication strategy. According to such a strategy, S partitions the interval (t_S^1, t_S^2) differently than in a z -equilibrium, each partition defining whether S randomizes over m_1 or m_3 or over m_1 or m_2 , however with the same mixing probabilities as above. For a given $j \in \{h, l\}$, the communication strategy δ_S determines $P_j(B | m_1, \delta_S)$ and $P_j(B | m_3, \delta_S)$. For a given $z \in (t_S^1, t_S^2)$, assume that δ_S is s.t. $P_j(B | m_1, \delta_S) = P_j(B | m_1, z)$. In steps 3-5, we show that this implies that in turn $P_j(B | m_3, \delta_S) \geq P_j(B | m_3, z)$.

Step 3 For a given z -strategy:

$$\frac{P_j(B, m_1, z)}{P_j(A, m_1, z)} = \frac{P_j(B)}{1 - P_j(B)} \frac{F_B(t_S^1) + \left(\frac{q_S - q_R}{1 - q_R}\right) (F_B(z) - F_B(t_S^1)) + q_S (F_B(t_S^2) - F_B(z))}{F_A(t_S^1) + \left(\frac{q_S - q_R}{1 - q_R}\right) (F_A(z) - F_A(t_S^1)) + q_S (F_A(t_S^2) - F_A(z))},$$

$$\frac{P_j(B, m_3, z)}{P_j(A, m_3, z)} = \frac{P_j(B)}{1 - P_j(B)} \frac{(F_B(z) - F_B(t_S^1))}{(F_A(z) - F_A(t_S^1))}.$$

Step 4 For a given z -strategy and a given δ_S , denote by $\underline{x}^1, \bar{x}^1, \underline{x}^2, \bar{x}^2, \dots, \underline{x}^n, \bar{x}^n$ the upper and lower bounds of the subintervals to the left of z where S 's behavior changes when transiting from the z -strategy to δ_S . Similarly, denote by $\underline{y}^1, \bar{y}^1, \underline{y}^2, \bar{y}^2, \dots, \underline{y}^m, \bar{y}^m$ the upper and lower bounds of the subintervals to the right of z where S 's behavior changes when transiting from the z -strategy to δ_S . Assume that there are n intervals in which S ' behavior changes to the left of z and m intervals in which it changes to the right of z .

Define

$$\begin{aligned}
I &= : F_B(t_S^1) + \left(\frac{q_S - q_R}{1 - q_R} \right) \left(F_B(z) - F_B(t_S^1) \right) + q_S \left(F_B(t_S^2) - F_B(z) \right), \\
J &= : F_A(t_S^1) + \left(\frac{q_S - q_R}{1 - q_R} \right) \left(F_A(z) - F_A(t_S^1) \right) + q_S \left(F_A(t_S^2) - F_A(z) \right), \\
C &= : F_B(z) - F_B(t_S^1), \\
D &= : F_A(z) - F_A(t_S^1).
\end{aligned}$$

Note that:

$$\begin{aligned}
& \frac{P_j(B, m_1, \delta_S)}{P_j(A, m_1, \delta_S)} \\
&= \frac{P_j(B) \left[I + \left(\frac{q_R(1-q_S)}{1-q_R} \right) \sum_{i=1}^n \left(F_B(\bar{x}^i) - F_B(\underline{x}^i) \right) - \left(\frac{q_R(1-q_S)}{1-q_R} \right) \sum_{i=1}^m \left(F_B(\bar{y}^i) - F_B(\underline{y}^i) \right) \right]}{1 - P_j(B) \left[J + \left(\frac{q_R(1-q_S)}{1-q_R} \right) \sum_{i=1}^n \left(F_B(\bar{x}^i) - F_B(\underline{x}^i) \right) - \left(\frac{q_R(1-q_S)}{1-q_R} \right) \sum_{i=1}^m \left(F_B(\bar{y}^i) - F_B(\underline{y}^i) \right) \right]}, \\
& \frac{P_j(B, m_3, \delta_S)}{P_j(A, m_3, \delta_S)} \\
&= \frac{P_j(B) \left[C - \left(\frac{(1-q_S)}{1-q_R} \right) \sum_{i=1}^n \left(F_B(\bar{x}^i) - F_B(\underline{x}^i) \right) + \left(\frac{(1-q_S)}{1-q_R} \right) \sum_{i=1}^m \left(F_B(\bar{y}^i) - F_B(\underline{y}^i) \right) \right]}{1 - P_j(B) \left[D - \left(\frac{(1-q_S)}{1-q_R} \right) \sum_{i=1}^n \left(F_B(\bar{x}^i) - F_B(\underline{x}^i) \right) + \left(\frac{(1-q_S)}{1-q_R} \right) \sum_{i=1}^m \left(F_B(\bar{y}^i) - F_B(\underline{y}^i) \right) \right]}.
\end{aligned}$$

Define

$$\begin{aligned}
Q_1 &= : \left(\frac{q_R(1-q_S)}{1-q_R} \right) \sum_{i=1}^n \left(F_B(\bar{x}^i) - F_B(\underline{x}^i) \right) - \left(\frac{q_R(1-q_S)}{1-q_R} \right) \sum_{i=1}^m \left(F_B(\bar{y}^i) - F_B(\underline{y}^i) \right), \\
Q_2 &= : \left(\frac{q_R(1-q_S)}{1-q_R} \right) \sum_{i=1}^n \left(F_B(\bar{x}^i) - F_B(\underline{x}^i) \right) - \left(\frac{q_R(1-q_S)}{1-q_R} \right) \sum_{i=1}^m \left(F_B(\bar{y}^i) - F_B(\underline{y}^i) \right).
\end{aligned}$$

Using the above introduced notation, one may thus rewrite:

$$\frac{P_j(B, m_1, \delta_S)}{P_j(A, m_1, \delta_S)} = \frac{P_j(B) \left[I + Q_1 \right]}{1 - P_j(B) \left[J + Q_2 \right]}$$

and

$$\frac{P_j(B, m_3, \delta_S)}{P_j(A, m_3, \delta_S)} = \frac{P_j(B) \left[I - \frac{1}{q_R} Q_1 \right]}{1 - P_j(B) \left[J - \frac{1}{q_R} Q_2 \right]}.$$

Step 5 Assuming that $\frac{P_j(B, m_1, z)}{P_j(B, m_1, \delta_S)} = \frac{P_j(B, m_1, \delta_S)}{P_j(B, m_1, \delta_S)}$ now implies two possibilities. Either,

$$(Q_1 = 0) \cap (Q_2 = 0) \tag{11}$$

or

$$\frac{Q_1}{Q_2} = \frac{P_j(B, m_1, z)}{P_j(A, m_1, z)}. \quad (12)$$

Call (11) and (12) respectively Cases 1 and 2. In Case 1, it follows trivially that $\frac{P_j(B, m_3, \delta_S)}{P_j(A, m_3, \delta_S)} = \frac{P_j(B, m_3)}{P_j(A, m_3)}$ given that

$$\frac{P_j(B, m_3, \delta_S)}{P_j(A, m_3, \delta_S)} = \frac{P_j(B)}{1 - P_j(B)} \frac{I - \frac{1}{q_R} Q_1}{J - \frac{1}{q_R} Q_2} = \frac{P_j(B)}{1 - P_j(B)} \frac{I - 0}{J - 0}.$$

In Case 2, on the other hand, it follows that $\frac{P_j(B, m_3, \delta_S)}{P_j(A, m_3, \delta_S)} > \frac{P_j(B, m_3, z)}{P_j(A, m_3, z)}$. The reason follows. Note that for any five positive constants B, C, D, E and α :

$$\frac{B - \alpha D}{C - \alpha E} > \frac{B}{C} \Leftrightarrow \frac{D}{E} < \frac{B}{C}.$$

Relating this to Case 2, the crucial fact is that we know that by definition, in any z -equilibrium

$$\frac{Q_1}{Q_2} = \frac{P_j(B, m_1, z)}{P_j(A, m_1, z)} < \frac{P_j(B, m_3, z)}{P_j(A, m_3, z)} = \frac{I}{J'}$$

This in turn implies that

$$\frac{I - \frac{1}{q_R} Q_1}{J - \frac{1}{q_R} Q_2} < \frac{I}{J} \quad (13)$$

Now, note that (13) is equivalent to

$$\begin{aligned} \frac{P_j(B)}{1 - P_j(B)} \frac{I - \frac{1}{q_R} Q_1}{J - \frac{1}{q_R} Q_2} &< \frac{P_j(B)}{1 - P_j(B)} \frac{I}{J} \Leftrightarrow \\ \frac{P_j(B, m_3, z)}{P_j(A, m_3, z)} &< \frac{P_j(B, m_3, \delta_S)}{P_j(A, m_3, \delta_S)}. \end{aligned}$$

Step 6 Note that for any value $P_j(B | m_1, \delta_S)$ that can be generated in an S -optimal equilibrium featuring an arbitrary strategy δ_S , there exists some z -strategy s.t. $P_j(B | m_1, z) = P_j(B | m_1, \delta_S)$. Indeed, note that, denoting by $P_j(B | m_1, z)$ the posterior generated by m_1 in the z -equilibrium, the function $P_j(B | m_1, z)$ is continuous in z on the interval $[t_S^1, t_S^2]$. Furthermore, $P_j(B | m_1, t_S^1)$ is trivially weakly larger than any value that may be taken by $P_j(B | m_1)$ in any equilibrium implementing the optimal decision rule of S . Similarly, $P_j(B | m_1, t_S^2)$ is trivially weakly smaller than any value that may be taken by $P_j(B | m_1)$ in any equilibrium implementing the optimal decision

rule of S . It follows that any value on the interval $[P_j(B | m_1, t_S^2), P_j(B | m_1, t_S^1)]$ may be achieved through some $z \in [t_S^1, t_S^2]$.

Step 7 Suppose a given arbitrary S -optimal equilibrium featuring the communication strategy δ_S . It follows that the following constraints hold:

$$\begin{aligned} P_h(B | m_1, \delta_S) &< q_R, \\ P_l(B | m_3, \delta_S) &< q_R \leq P_h(B | m_3, \delta_S), \\ q_R &\leq P_l(B | m_2, \delta_S). \end{aligned}$$

Now, first, from step 6, we know that there exists some z^* s.t that $P_h(B | m_1, z^*) = P_h(B | m_1, \delta_S)$. Secondly, we know from steps 1-5 that for such a z^* , $P_l(B | m_3, z^*) < P_l(B | m_3, \delta_S)$. Finally, it is trivially true that for such a z^* , $q_R \leq P_h(B | m_3, z^*)$ and $q_R \leq P_l(B | m_2, z^*)$. It follows that if there exists some arbitrary equilibrium implementing the optimal decision rule of S , then there exists a z -equilibrium. ■

7 Appendix C: Proof of Proposition 2

Our proof of Proposition 2 is articulated into three main parts. We start by stating Proposition 8 below. In the first subsection of our proof, we characterize constraints ensuring the existence of a given z -equilibrium for a fixed level of ambiguity. In the second part of our proof of Proposition 2, corresponding to the second subsection of our proof, we vary the level of ambiguity and summarize existence conditions in two main cases corresponding to respectively low and high ambiguity. In the third part of our proof, corresponding to the third subsection, we directly relate our findings to Proposition 2.

Proposition 8 *A characterization of the set of z -equilibria*

Assume that (2) is satisfied. Given q_S , there exists a threshold $e_1(q_S) > 0$ s.t.:

a) If $e < e_1(q_S)$, then for any $z \geq t_S^1(q_S, e)$, there exist thresholds $\{q_{\underline{R}}(z), \bar{q}_R(z)\}$ satisfying $q_{\underline{R}}(z) < \bar{q}_R(z) \leq q_S$ s.t. the z -equilibrium exists iff $q_R \in [q_{\underline{R}}(z), \bar{q}_R(z)]$. For any $z \geq t_S^1(q_S, e)$, the lower bound $q_{\underline{R}}(z)$ is continuous in z (except at $z = t_S^1(q_S, e)$) and strictly increasing in z . For any $z \geq t_S^1(q_S, e)$, the upper bound $\bar{q}_R(z)$ is continuous in z and weakly increasing in z and $\bar{q}_R(t_S^2(q_S, e)) = q_S$.

b) If $e \geq e_1(q_S)$, then there exists $\tilde{z} \in [t_S^1(q_S, e), t_S^2(q_S, e)]$ such that the following is true: 1) If $z < \tilde{z}$, there the z -equilibrium does not exist, $\forall q_R$. 2) If $z \geq \tilde{z}$, there exist thresholds $\{q_{\underline{R}}(z), \bar{q}_R(z)\}$

satisfying $\underline{q}_R(z) < \bar{q}_R(z)$ s.t. the z -equilibrium exists iff $q_R \in [\underline{q}_R(z), \bar{q}_R(z)]$. Furthermore, there is a $z^* \in (\tilde{z}, t_S^2(q_S, e)]$ s.t. for any $z \in [\tilde{z}, z^*]$ the lower bound $\underline{q}_R(z)$ is continuous in z and strictly decreasing in z , while for $z \in (z^*, t_S^2(q_S, e)]$, the lower bound $\underline{q}_R(z)$ is continuous in z and strictly increasing in z . For any $z \geq \tilde{z}$, the upper bound $\bar{q}_R(z)$ is continuous in z and weakly increasing in z and $\bar{q}_R(t_S^2(q_S, e)) = q_S$.

7.1 A preliminary analysis of constraints

Step 1 In a z -equilibrium, we denote the Bayesian conditional probability determined by message m_i , under prior P_j^e , by $P_j(B | m_1, z, q_R, q_S, e)$. Note that the z -equilibrium exists iff

$$P_h(B | m_1, z, q_R, q_S, e) \leq q_R, \quad (14)$$

$$P_l(B | m_3, z, q_R, q_S, e) \leq q_R \quad (15)$$

$$q_R \leq P_h(B | m_3, z, q_R, q_S, e). \quad (16)$$

$$q_R \leq P_l(B | m_2, z, q_R, q_S, e). \quad (17)$$

Note that (16) is trivially always true because by definition, $q_S \leq P_h(B | m_3, z, q_R, q_S, e)$. We thus focus on the remaining three inequalities.

Step 2 In steps 2 to 7, we shall focus on the inequality (14) and study the function

$$g(q_R) := P_h(B | m_1, z, q_R, q_S, e) - q_R, \quad (18)$$

for $q_R \in [0, q_S]$, for any fixed $z \in [t_S^1, t_S^2]$, and analyze the implicit function of z that it defines. Note that condition (14) holds if and only if $g(q_R) \leq 0$. In remaining steps, we provide a treatment of inequalities (15) and (17).

Step 3 Note that

$$\frac{P_h(B, m_1, z, q_R, q_S, e)}{P_h(A, m_1, z, q_R, q_S, e)} = \frac{P_h(B) F_B(t_S^1) + \left(\frac{q_S - q_R}{1 - q_R}\right) (F_B(z) - F_B(t_S^1)) + q_S (F_B(t_S^2) - F_B(z))}{1 - P_h(B) F_A(t_S^1) + \left(\frac{q_S - q_R}{1 - q_R}\right) (F_A(z) - F_A(t_S^1)) + q_S (F_A(t_S^2) - F_A(z))}.$$

Step 4 For any given $z \in [t_S^1, t_S^2]$, note that

$$\frac{P_h(B, m_1, z, 0, q_S, e)}{P_h(A, m_1, z, 0, q_S, e)} > 0 \Leftrightarrow g(0) > 0.$$

On the other hand, it may or may not be the case that

$$\frac{P_h(B, m_1, z, q_S, q_S, e)}{P_h(A, m_1, z, q_S, q_S, e)} < \frac{q_S}{1 - q_S} \Leftrightarrow g(q_S) < 0.$$

Step 5 For given q_R and $\tilde{q}_R \in (q_R, q_S]$,

$$\frac{P_h(B, m_1, z, q_R, q_S, e)}{P_h(A, m_1, z, q_R, q_S, e)} < \frac{q_R}{1 - q_R} \Rightarrow \frac{P_h(B, m_1, z, q_R, q_S, e)}{P_h(A, m_1, z, q_R, q_S, e)} < \frac{\tilde{q}_R}{1 - \tilde{q}_R}.$$

We now prove the above statement. Note first that $q_R < q_S$ implies that $t_R^1 < t_S^1$, which in turn implies that

$$\frac{P_h(B)}{1 - P_h(B)} \frac{F_B(z) - F_B(t_S^1)}{F_A(z) - F_A(t_S^1)} > \frac{q_R}{1 - q_R}. \quad (19)$$

Note secondly that

$$\frac{\partial \left(\frac{q_S - q_R}{1 - q_R} \right)}{\partial q_R} < 0, \quad \forall q_R \in (0, q_S) \quad (20)$$

It follows from (19) and (20) that if

$$\frac{P_h(B)}{1 - P_h(B)} \frac{F_B(t_S^1) + \left(\frac{q_S - q_R}{1 - q_R} \right) (F_B(z) - F_B(t_S^1)) + q_S (F_B(t_S^2) - F_B(z))}{F_A(t_S^1) + \left(\frac{q_S - q_R}{1 - q_R} \right) (F_A(z) - F_A(t_S^1)) + q_S (F_A(t_S^2) - F_A(z))} < \frac{q_R}{1 - q_R},$$

then a fortiori for $\tilde{q}_R \in (q_R, q_S]$

$$\frac{P_h(B)}{1 - P_h(B)} \frac{F_B(t_S^1) + \left(\frac{q_S - \tilde{q}_R}{1 - \tilde{q}_R} \right) (F_B(z) - F_B(t_S^1)) + q_S (F_B(t_S^2) - F_B(z))}{F_A(t_S^1) + \left(\frac{q_S - \tilde{q}_R}{1 - \tilde{q}_R} \right) (F_A(z) - F_A(t_S^1)) + q_S (F_A(t_S^2) - F_A(z))} < \frac{q_R}{1 - q_R} < \frac{\tilde{q}_R}{1 - \tilde{q}_R}.$$

Step 6 We now know four facts about the function $g(q_R) = P_h(B | m_1, z, q_R, q_S, e) - q_R$. First, $g(0) > 0$. Second either $g(q_S) < 0$ or $g(q_S) \geq 0$. Third, for $q_R < q_S$, if $g(q_R) < 0$, then $g(q_R) < 0$ for $q_R \in (q_R, q_S]$. Fourth, $g(q_R)$ is trivially continuous in q_R , for any $q_R \in (0, 1)$. It follows that we can distinguish two cases. If $g(q_S) < 0$ (Case 1), a single crossing condition holds and that there exists a unique $\underline{q}_R^1(z) \in (0, q_S)$ s.t $g(q_R) \leq 0$ iff $q_R \in [\underline{q}_R^1(z), q_S]$, i.e. s.t. (14) holds iff $q_R \in [\underline{q}_R^1(z), q_S]$. If on the other hand, $g(q_S) \geq 0$ (Case 2), then $g(q_R) \geq 0, \forall q_R \in (0, q_S)$. It follows that (14) holds iff $q_R \geq q_S$.

Step 7 It follows from the above steps that the equality

$$\frac{P_h(B, m_1, z, q_R, q_S, e)}{P_h(A, m_1, z, q_R, q_S, e)} = \frac{q_R}{1 - q_R}$$

defines an implicit function $\Psi(z, q_S, e)$, continuous in z and q_S , which indicates, for every pair (z, q_S) , the unique value of q_R s.t. the above equality holds. We now wish to establish whether

$\Psi(z, q_S, e)$ is decreasing or increasing in z . To answer this question, note the following two facts.

First:

$$\frac{\partial \left(\frac{P_h(B, m_1, z, q_R, q_S, e)}{P_h(A, m_1, z, q_R, q_S, e)} \right)}{\partial z} = \frac{P_h(B)}{1 - P_h(B)} \frac{-f_B(z) [F_B(t_S^2) - F_B(z)] + f_A(z) [F_B(t_S^2) - F_B(z)]}{(P_h(A, m_1, z, q_R, q_S))^2} < 0.$$

This is true, because the above inequality is equivalent to the condition that

$$\frac{f_B(z)}{f_A(z)} < \frac{F_B(t_S^2) - F_B(z)}{F_A(t_S^2) - F_A(z)},$$

which is always true. Second, it follows from the fact that $\frac{\partial \left(\frac{q_S - q_R}{1 - q_R} \right)}{\partial q_R} < 0, \forall q_S, \forall q_R < q_S$ that

$$\frac{\partial \left(\frac{P_h(B, m_1, z, q_R, q_S, e)}{P_h(A, m_1, z, q_R, q_S, e)} \right)}{\partial q_R} > 0.$$

It follows from the above that the implicit function $\Psi(z, q_S, Y)$ is strictly decreasing in z .

Step 8 This step focuses on the inequality (15). Note that

$$\frac{P_l(B, m_3, z, q_R, q_S, e)}{P_l(A, m_3, z, q_R, q_S, e)} = \frac{P_l(B)}{1 - P_l(B)} \frac{F_B(z) - F_B(t_S^1)}{F_A(z) - F_A(t_S^1)} < \frac{q_S}{1 - q_S}.$$

It follows immediately that there is a $\underline{q}_R^2(z) \in (0, q_S)$ s.t (15) holds iff $q_R \in [\underline{q}_R^2(z), q_S]$. Note furthermore, for further notice, that it is trivially true that $\forall z$

$$\frac{\partial \left(\frac{P_l(B, m_3, z, q_R, q_S, e)}{P_l(A, m_3, z, q_R, q_S, e)} \right)}{\partial z} > 0.$$

Step 9 Given the results provided in steps 2 to 7, it follows that for any z , there exists a $\underline{q}_R(z) = \max \left\{ \underline{q}_R^1(z), \underline{q}_R^2(z) \right\} \in (0, q_S]$ s.t. (14) and (15) hold simultaneously if and only if $q_R > \underline{q}_R(z)$. Recall indeed that condition (14) holds if and only if, for given z , $q_R \geq \Psi(z, q_S, Y)$ while (15) holds if and only if $q_R \geq P_l(B | m_3, z, q_R, q_S, e)$.

Step 10 We now focus on conditions ensuring that (17) is true, i.e. ensuring that $q_R \leq P_l(B | m_2, z, q_R, q_S, e)$. Note that for any z , $P_l(B | m_2, z, q_R, q_S, e)$ is independent of q_R . It follows that there is some upper bound $\bar{q}_R(z)$ s.t. (17) holds if and only if $q_R < \bar{q}_R(z)$. We summarize the four following facts about the function $P_l(B | m_2, z, q_R, q_S, e)$: it is continuous in z and monotonously increasing in z (Fact A), it is independent of q_R (Fact B), $P_l(B | m_2, t_S^2, q_R, q_S, e) > q_S$ (Fact C) and finally $P_l(B | m_2, z, q_R, q_S, e) > P_l(B | m_3, z, q_R, q_S, e), \forall z$ (Fact D). ■

7.2 Low vs high ambiguity

Step 1 We make use of the following measure of ambiguity in what follows

$$Y(e) = \frac{\frac{P_h^e(B)}{1-P_h^e(B)}}{\frac{P_l^e(B)}{1-P_l^e(B)}} = \left(\frac{\frac{1}{2} + e}{\frac{1}{2} - e} \right)^2$$

If ambiguity is entirely absent, then $Y(e) = 1$. On the other hand, as ambiguity increases, $Y(e)$ tends to infinity. Note that for each e , there is a unique corresponding value of $Y(e)$. In what follows, we abusively ignore the dependence of t_S^1 and t_S^2 on the values of q_S and instead explicitly indicate the dependence of t_S^1 and t_S^2 on the ambiguity level e by denoting them as $t_S^1(Y)$ and $t_S^2(Y)$. Note that we slightly abuse notation and generally use Y instead of e in what follows, which is unproblematic to the extent that for each e , there is a unique corresponding value of $Y(e)$. We shall prove comparative statics properties of the four constraints stated in step 1 of the preceding subsection by analyzing how changes in e affect the relationship between the functions $P_l(B | m_3, z, q_R, q_S, Y)$, $P_l(B | m_2, z, q_R, q_S, Y)$ and $\Psi(z, q_S, Y)$. We will mostly focus on the relative value of these functions at $z = t_S^1(Y)$, which plays a crucial role.

Step 2 Note that:

$$\begin{aligned} \frac{P_l(B, m_3, t_S^1(Y), q_R, q_S, Y)}{P_l(A, m_3, t_S^1(Y), q_R, q_S, Y)} &= \frac{P_l^Y(B) f_B(t_S^1(Y))}{1 - P_l^Y(B) f_A(t_S^1(Y))} \\ \frac{\Psi(t_S^1(Y), q_S, Y)}{1 - \Psi(t_S^1(Y), q_S, Y)} &= \frac{P_h^Y(B) F_B(t_S^1(Y)) + q_S (F_B(t_S^2(Y)) - F_B(t_S^1(Y)))}{1 - P_h^Y(B) F_A(t_S^1(Y)) + q_S (F_A(t_S^2(Y)) - F_A(t_S^1(Y)))} \\ &= \frac{P_h(B, m_1, t_S^1(Y), q_R, q_S, Y)}{P_h(A, m_1, t_S^1(Y), q_R, q_S, Y)}. \end{aligned}$$

The salient fact here is that the function $\Psi(t_S^1(Y), q_S, Y)$ has a very simple form for $z = t_S^1(Y)$.

Step 3 In this step, we prove that there is an $Y_0 > 1$ s.t. for $Y < Y_0$

$$\frac{f_B(t_S^1(Y))}{f_A(t_S^1(Y))} > \frac{F_B(t_S^1(Y)) + q_S (F_B(t_S^2(Y)) - F_B(t_S^1(Y)))}{F_A(t_S^1(Y)) + q_S (F_A(t_S^2(Y)) - F_A(t_S^1(Y)))}$$

while the inequality holds with the sign $<$ if $Y > Y_0$ and holds as an equality for $Y = Y_0$.

Note first the following facts. **Fact 1** is given as follows:

$$\frac{f_B(t_S^1(1))}{f_A(t_S^1(1))} > \frac{F_B(t_S^1(1)) + q_S (F_B(t_S^2(1)) - F_B(t_S^1(1)))}{F_A(t_S^1(1)) + q_S (F_A(t_S^2(1)) - F_A(t_S^1(1)))} = \frac{F_B(t_S^1(1))}{F_B(t_S^1(1))}$$

Note furthermore that (call this **Fact 2**) $\lim_{Y \rightarrow \infty} t_S^1(Y) = l$ so that

$$\lim_{Y \rightarrow \infty} \frac{f_B(t_S^1(Y))}{f_A(t_S^1(Y))} < \lim_{Y \rightarrow \infty} \frac{F_B(t_S^1(Y)) + q_S (F_B(t_S^2(Y)) - F_B(t_S^1(Y)))}{F_A(t_S^1(Y)) + q_S (F_A(t_S^2(Y)) - F_A(t_S^1(Y)))} = \frac{F_B(t_S^2(Y)) - F_B(t_S^1(Y))}{F_A(t_S^2(Y)) - F_A(t_S^1(Y))}$$

Note also that (call this **Fact 3**) if for a given Y

$$\frac{F_B(t_S^1(Y)) + q_S (F_B(t_S^2(Y)) - F_B(t_S^1(Y)))}{F_A(t_S^1(Y)) + q_S (F_A(t_S^2(Y)) - F_A(t_S^1(Y)))} > \frac{f_B(t_S^1(Y))}{f_A(t_S^1(Y))}, \quad (21)$$

then for any $Y' > Y$

$$\frac{F_B(t_S^1(Y)) + q_S (F_B(t_S^2(Y')) - F_B(t_S^1(Y')))}{F_A(t_S^1(Y')) + q_S (F_A(t_S^2(Y')) - F_A(t_S^1(Y')))} > \frac{f_B(t_S^1(Y))}{f_A(t_S^1(Y))} > \frac{f_B(t_S^1(Y'))}{f_A(t_S^1(Y'))}$$

To see that **Fact 3** is true, note the following three points. First,

$$\frac{F_B(t_S^1(Y)) + q_S (F_B(t_S^2(Y)) - F_B(t_S^1(Y)))}{F_A(t_S^1(Y)) + q_S (F_A(t_S^2(Y)) - F_A(t_S^1(Y)))} = \frac{(1 - q_S) F_B(t_S^1(Y)) + q_S F_B(t_S^2(Y))}{(1 - q_S) F_A(t_S^1(Y)) + q_S F_A(t_S^2(Y))}$$

Second, given that $t_S^1(Y') < t_S^1(Y)$ and $\frac{f_B(t_S^1(Y))}{f_A(t_S^1(Y))}$ is decreasing in Y over $[1, +\infty)$, if (21) is true, then it is true that

$$\frac{(F_B(t_S^1(Y)) - F_B(t_S^1(Y')))}{(F_A(t_S^1(Y)) - F_A(t_S^1(Y')))} < \frac{(1 - q_S) F_B(t_S^1(Y)) + q_S F_B(t_S^2(Y))}{(1 - q_S) F_A(t_S^1(Y)) + q_S F_A(t_S^2(Y))}'$$

which in turn implies

$$\begin{aligned} & \frac{(1 - q_S) F_B(t_S^1(Y')) + q_S F_B(t_S^2(Y))}{(1 - q_S) F_A(t_S^1(Y')) + q_S F_A(t_S^2(Y))} \\ = & \frac{(1 - q_S) F_B(t_S^1(Y)) - (1 - q_S) (F_B(t_S^1(Y)) - F_B(t_S^1(Y')) + q_S F_B(t_S^2(Y)))}{(1 - q_S) F_A(t_S^1(Y)) - (1 - q_S) (F_A(t_S^1(Y)) - F_A(t_S^1(Y')) + q_S F_A(t_S^2(Y)))} \\ > & \frac{(1 - q_S) F_B(t_S^1(Y)) + q_S F_B(t_S^2(Y))}{(1 - q_S) F_A(t_S^1(Y)) + q_S F_A(t_S^2(Y))} \end{aligned}$$

Third, note that given that $t_S^2(Y') > t_S^2(Y)$ and that $\frac{f_B(t_S^1(Y))}{f_A(t_S^1(Y))}$ is monotonously decreasing in Y over $[1, +\infty)$, if (21) is true, then it is true that

$$\frac{F_B(t_S^2(Y')) - F_B(t_S^2(Y))}{F_B(t_S^2(Y')) - F_B(t_S^2(Y))} > \frac{(1 - q_S) F_B(t_S^1(Y)) + q_S F_B(t_S^2(Y))}{(1 - q_S) F_B(t_S^1(Y)) + q_S F_B(t_S^2(Y))}'$$

which in turn implies

$$\begin{aligned}
& \frac{(1 - q_S) F_B(t_S^1(Y')) + q_S F_B(t_S^2(Y'))}{(1 - q_S) F_A(t_S^1(Y')) + q_S F_A(t_S^2(Y'))} \\
= & \frac{(1 - q_S) F_B(t_S^1(Y')) + q_S F_B(t_S^2(Y)) + q_S (F_B(t_S^2(Y')) - F_B(t_S^2(Y)))}{(1 - q_S) F_A(t_S^1(Y')) + q_S F_A(t_S^2(Y)) + q_S (F_A(t_S^2(Y')) - F_A(t_S^2(Y)))} \\
> & \frac{(1 - q_S) F_B(t_S^1(Y')) + q_S F_B(t_S^2(Y))}{(1 - q_S) F_A(t_S^1(Y')) + q_S F_A(t_S^2(Y))}
\end{aligned}$$

It follows from the above three points that if (21) is true, then it is true that

$$\frac{(1 - q_S) F_B(t_S^1(Y')) + q_S F_B(t_S^2(Y'))}{(1 - q_S) F_A(t_S^1(Y')) + q_S F_A(t_S^2(Y'))} > \frac{(1 - q_S) F_B(t_S^1(Y)) + q_S F_B(t_S^2(Y))}{(1 - q_S) F_A(t_S^1(Y)) + q_S F_A(t_S^2(Y))} > \frac{f_B(t_S^1(Y))}{f_A(t_S^1(Y))} > \frac{f_B(t_S^1(Y'))}{f_A(t_S^1(Y'))},$$

which concludes the proof of Fact 3 given above.

Finally, note that both $\frac{F_B(t_S^1(Y)) + q_S (F_B(t_S^2(Y)) - F_B(t_S^1(Y)))}{F_A(t_S^1(Y)) + q_S (F_A(t_S^2(Y)) - F_A(t_S^1(Y)))}$ and $\frac{f_B(t_S^1(Y))}{f_A(t_S^1(Y))}$ are continuous functions of Y on the interval $[1, +\infty)$ (call this **Fact 4**). It follows from facts 1, 2, 3 and 4 that a single crossing condition holds and that there exists a constant

$$Y_0 = \frac{\frac{f_B(t_S^1(Y))}{f_A(t_S^1(Y))}}{\frac{F_B(t_S^1(Y)) + q_S (F_B(t_S^2(Y)) - F_B(t_S^1(Y)))}{F_A(t_S^1(Y)) + q_S (F_A(t_S^2(Y)) - F_A(t_S^1(Y)))}} > 1$$

s.t. the function $\frac{f_B(t_S^1(Y))}{f_A(t_S^1(Y))}$ crosses $\frac{F_B(t_S^1(Y)) + q_S (F_B(t_S^2(Y)) - F_B(t_S^1(Y)))}{F_A(t_S^1(Y)) + q_S (F_A(t_S^2(Y)) - F_A(t_S^1(Y)))}$ from above at $Y = Y_0$.

Step 4 It is shown in Appendix D that if (2) is true, then

$$\frac{\partial \left(\frac{F_B(t_S^1(e))}{F_A(t_S^1(e))} \left(\frac{\frac{1}{2} + e}{\frac{1}{2} - e} \right) \right)}{\partial e} \geq 0. \text{ (Fact F.1)} \tag{22}$$

Step 5 We now show that the ratio

$$\frac{\frac{f_B(t_S^1(Y))}{f_A(t_S^1(Y))} \frac{P_l^Y(B)}{1 - P_l^Y(B)}}{\frac{F_B(t_S^1(Y)) + q_S (F_B(t_S^2(Y)) - F_B(t_S^1(Y)))}{F_A(t_S^1(Y)) + q_S (F_A(t_S^2(Y)) - F_A(t_S^1(Y)))} \frac{P_h^Y(B)}{1 - P_h^Y(B)}}$$

is increasing in Y if condition (2) is respected. We know that the numerator is decreasing in e (equivalently, Y), so we simply show that the denominator is decreasing in e . This corresponds to Fact F.2 which is proved in Appendix D.

Step 6 Given Steps 3, 4 and 5, it is clear that there is a constant $Y_1 > 0$, with $Y_1 < Y_0$ s.t. if $Y < Y_1$

$$\frac{P_l(B, m_3, t_S^1(Y), q_R, q_S, Y)}{P_l(A, m_3, t_S^1(Y), q_R, q_S, Y)} > \frac{\Psi(t_S^1(Y), q_S, Y)}{1 - \Psi(t_S^1(Y), q_S, Y)},$$

while the inequality is reversed if $Y > Y_1$ and holds as an equality for $Y = Y_1$.

Step 7 This corresponds to point a) in Proposition 8. For $Y < Y_1$, it follows that $P_l(B | m_3, z, q_R, q_S, Y) > \Psi(z, q_S, Y), \forall z \in [t_S^1(Y), t_S^2(Y)]$. Now, recall facts A,B,C and D stated about the function $P_l(B | m_2, z, q_R, q_S, Y)$. It follows that for any $z \geq t_S^1(Y)$, inequality (25) holds. It follows that for any $Y < Y_1, \frac{\partial q_R(z)}{\partial z} > 0, \forall z > t_S^1(Y)$. Note that there is a discontinuity in the function $q_R(z)$ at $z = t_S^1(Y)$. Indeed,

$$q_R(t_S^1(Y)) = \Psi(t_S^1(Y), q_S, Y) < P_l(B | m_3, t_S^1(Y), q_R, q_S, Y)$$

while for $z > t_S^1(Y), q_R(z) = P_l(B | m_3, z, q_R, q_S, Y)$. Also, it follows that for any $z \geq t_S^1(Y), \bar{q}_R(z)$ is weakly increasing in z .

Step 8 This corresponds to point b) in Proposition 8. Assume $Y > Y_1$. Two cases must here be considered, which we call respectively case I and II. In case I:

$$\frac{P_l(B, m_3, t_S^1(Y), q_R, q_S, Y)}{P_l(A, m_3, t_S^1(Y), q_R, q_S, Y)} < \frac{\Psi(t_S^1(Y), q_S, Y)}{1 - \Psi(t_S^1(Y), q_S, Y)} \quad (23)$$

and

$$\frac{P_l(B, m_3, t_S^2(Y), q_R, q_S, Y)}{P_l(A, m_3, t_S^2(Y), q_R, q_S, Y)} > \frac{\Psi(t_S^2(Y), q_S, Y)}{1 - \Psi(t_S^2(Y), q_S, Y)}. \quad (24)$$

In case II, (23) holds as well while (24) is reversed. We consider Case I in what follows. Recall that $\frac{\partial(\Psi(z, q_S, Y))}{\partial z} < 0$ while $\frac{\partial(\frac{P_l(B, m_3, z, q_R, q_S, Y)}{P_l(A, m_3, z, q_R, q_S, Y)})}{\partial z} > 0$, for any z . It follows that there is a $z^* \in [t_S^1(Y), t_S^2(Y)]$ s.t. $P_l(B | m_3, z, q_R, q_S, Y) < \Psi(z, q_S, Y), \forall z \in [t_S^1(Y), z^*]$ while $P_l(B | m_3, z, q_R, q_S, Y) > \Psi(z, q_S, Y), \forall z \in (z^*, t_S^2(Y)]$.

Now, recall the four following facts about the function $P_l(B | m_2, z, q_R, q_S, Y)$: it is continuous in z and monotonously increasing in z (Fact A), it is independent of q_R (Fact B), $P_l(B | m_2, t_S^2(Y), q_R, q_S, Y) > q_S$ (Fact C) and finally $P_l(B | m_2, z, q_R, q_S, Y) > P_l(B | m_3, z, q_R, q_S, Y), \forall z$ (Fact D). It follows that there is some $\tilde{z} \geq t_S^1(Y)$ s.t. for any $z \geq \tilde{z}$,

$$P_l(B | m_2, z, q_R, q_S, Y) > \max \{P_h(B | m_1, z, q_R, q_S, Y), P_l(B | m_3, z, q_R, q_S, Y)\}. \quad (25)$$

We may conclude that for $Y > Y_1$, there is a $z^* > \tilde{z}$ s.t. $\frac{\partial q_R(z)}{\partial z} < 0$ for $\tilde{z} \leq z < z^*$ and $\frac{\partial q_R(z)}{\partial z} > 0$ for $z > z^*$. Also, it follows that for any $z \geq \tilde{z}, \bar{q}_R(z)$ is weakly increasing in z .

We consider Case II in what follows. Here, it follows that $P_l(B | m_3, z, q_R, q_S, Y) < \Psi(z, q_S, Y), \forall z \in [t_S^1(Y), t_S^2(Y)]$. Now, recall facts A,B,C and D stated about the function $P_l(B | m_2, z, q_R, q_S, Y)$. It follows immediately that there is some $\tilde{z} \geq t_S^1(Y)$ s.t. for any $z \geq \tilde{z}$, inequality (25) holds. It follows that, $\frac{\partial q_R(z)}{\partial z} < 0$ for any $z > \tilde{z}$. Also, it follows that for any $z \geq \tilde{z}, \bar{q}_R(z)$ is weakly increasing in z . ■

7.3 Relating Proposition 8 to Proposition 2

Step 1 This proves Point i of Proposition 2 on the basis of Proposition 8. Suppose $Y < Y_1 = Y(e_1(q_S))$. Then for any $q_R < \underline{q}_R(t_S^1(Y))$, there is no z-equilibrium. For $q_R \in [\underline{q}_R(t_S^1(Y)), \bar{q}_R(t_S^1(Y))]$, the z-equilibrium given by $z = t_S^1(Y)$ exists. For $q_R > \bar{q}_R(t_S^1(Y))$, the z-equilibrium given by $z = t_S^2(Y)$ exists. Suppose $Y \geq Y_1(e_1(q_S))$. Then for any $q_R < \underline{q}_R(z^*)$, there is no z-equilibrium. For any $q_R \in [\underline{q}_R(z^*), \bar{q}_R(t_S^2(Y))]$, the z-equilibrium given by $z = z^*$ exists. For any $q_R \in [\bar{q}_R(t_S^2(Y)), q_S]$, the z-equilibrium given by $z = t_S^2(Y)$ exists.

Step 2 This proves Points ii.a) of Proposition 2 on the basis of Proposition 8. We here exclusively consider z-equilibrium for which $z = t_S^1(e)$. Recall the three constraints stated in the beginning of the first subsection of this Appendix. The constraint that $q_R < P_l(B | m_2, z = t_S^1(e), q_R, q_S, e)$ corresponds to the inequality (17). Constraint (14) determines the requirement that

$$q_R > \Psi(t_S^1(e), q_S, e) = P_h(B | m_1, t_S^1(e), q_R, q_S, e)$$

Constraint (15) is clearly irrelevant for the case of $z = t_S^1(e)$ and only relevant for the case of $z > t_S^1(e)$. It requires that

$$q_R > P_l(B | m_3, t_S^1(e), q_R, q_S, e)$$

So, for any e , an S-optimal equilibrium using only two messages exists for some values of q_R iff

$$\frac{P_h(B, m_1, t_S^1(e), q_R, q_S, e)}{P_h(A, m_1, t_S^1(e), q_R, q_S, e)} < \min \left\{ q_S, \frac{P_l(B, m_2, z = t_S^1(e), q_R, q_S, e)}{P_l(A, m_2, z = t_S^1(e), q_R, q_S, e)} \right\}.$$

We also know that for $e = 0$,

$$\frac{P_h(B, m_1, t_S^1(e), q_R, q_S, e)}{P_h(A, m_1, t_S^1(e), q_R, q_S, e)} < q_S < \frac{P_l(B, m_2, z = t_S^1(e), q_R, q_S, e)}{P_l(A, m_2, z = t_S^1(e), q_R, q_S, e)}.$$

Secondly, we know that under our assumptions:

$$\frac{\partial \left(\frac{P_h(B, m_1, t_S^1(e), q_R, q_S, e)}{P_h(A, m_1, t_S^1(e), q_R, q_S, e)} \right)}{\partial e} > 0, \forall e.$$

Third, we could similarly prove that under our assumptions

$$\frac{\partial \left(\frac{P_l(B, m_2, z = t_S^1(e), q_R, q_S, e)}{P_l(A, m_2, z = t_S^1(e), q_R, q_S, e)} \right)}{\partial e} < 0, \forall e.$$

It follows that there exists an $e_3(q_S) > 0$ such that

$$\frac{P_h(B, m_1, t_S^1(e), q_R, q_S, e)}{P_h(A, m_1, t_S^1(e), q_R, q_S, e)} > \min \left\{ \frac{P_l(B, m_2, z = t_S^1(e), q_R, q_S, e)}{P_l(A, m_2, z = t_S^1(e), q_R, q_S, e)}, q_S \right\},$$

while the inequality holds in the opposite direction for $e < e_3(q_S)$. It follows that there exists an $e_3(q_S) > 0$ s.t. for $e \in (0, e_3(q_S))$, there exists a non empty interval of values of q_R for which there exists an S -optimal equilibrium with two messages while for $e > e_3(q_S)$, there exists no value of q_R for which there exists an S -optimal equilibrium with two messages.

Step 3 This step proves Points ii.b) and ii.c) of Proposition 2 on the basis of Proposition 8. We know the following three facts. First, there is some $e_1(q_S)$ s.t.

$$\frac{P_h(B, m_1, t_S^1(e), q_R, q_S, e)}{P_h(A, m_1, t_S^1(e), q_R, q_S, e)} = \frac{P_l(B, m_3, t_S^1(e), q_R, q_S, e)}{P_l(A, m_3, t_S^1(e), q_R, q_S, e)}.$$

Second,

$$\frac{P_l(B, m_3, t_S^1(e), q_R, q_S, e)}{P_l(A, m_3, t_S^1(e), q_R, q_S, e)} < \frac{P_l(B, m_2, z = t_S^1(e), q_R, q_S, e)}{P_l(A, m_2, z = t_S^1(e), q_R, q_S, e)}.$$

Third,

$$\frac{\partial \left(\frac{P_l(B, m_2, z = t_S^1(e), q_R, q_S, e)}{P_l(A, m_2, z = t_S^1(e), q_R, q_S, e)} \right)}{\partial e} < 0, \forall e.$$

It follows immediately that $e_1(q_S) < e_3(q_S)$. This shows that the lower bound on the interval of values compatible with the existence of an S -optimal equilibrium using only two messages is equal to the lower bound under three messages as long as $e < e_1(q_S)$, while it is strictly larger if $e \in [e_1(q_S), e_3(q_S)]$. Finally, as to the upper bound on the interval of values of q_R compatible with the existence of an S -optimal equilibrium using two messages, note simply that it is trivially true that there is some $e_2(q_S)$ s.t. for $e > e_2(q_S)$

$$\frac{P_l(B, m_2, z = t_S^1(e), q_R, q_S, e)}{P_l(A, m_2, z = t_S^1(e), q_R, q_S, e)} < q_S.$$

while the inequality is reversed if $e < e_2(q_S)$. Note however that e_2 could be situated anywhere w.r.t. $e_1(q_S)$ and $e_3(q_S)$. ■

8 Appendix D: Lemmas and Facts

8.1 Proof of Lemma 3

Step 1 We prove only Point a). The proof of Point b) follows the same steps, but is substantially simpler. Note that

$$\frac{\frac{F_B(\sigma)}{F_A(\sigma)}}{\frac{\partial \left(\frac{F_B(\sigma)}{F_A(\sigma)} \right)}{\partial \sigma}} > \frac{\frac{f_B(\sigma)}{f_A(\sigma)}}{\frac{\partial \left(\frac{f_B(\sigma)}{f_A(\sigma)} \right)}{\partial \sigma}}, \forall \sigma \Leftrightarrow \frac{\partial \left(\frac{F_B(\sigma)}{F_A(\sigma)} \right)}{\frac{F_B(\sigma)}{F_A(\sigma)}} < \frac{\partial \left(\frac{f_B(\sigma)}{f_A(\sigma)} \right)}{\frac{f_B(\sigma)}{f_A(\sigma)}}, \forall \sigma \Leftrightarrow \quad (26)$$

$$\frac{\partial \left(\log \left(\frac{F_B(\sigma)}{F_A(\sigma)} \right) \right)}{\partial \sigma} < \frac{\partial \left(\log \left(\frac{f_B(\sigma)}{f_A(\sigma)} \right) \right)}{\partial \sigma}, \forall \sigma \Leftrightarrow \quad (27)$$

$$\frac{\partial \left(\log \left(\frac{f_A(\sigma)}{F_A(\sigma)} \right) \right)}{\partial \sigma} < \frac{\partial \left(\log \left(\frac{f_B(\sigma)}{F_B(\sigma)} \right) \right)}{\partial \sigma}, \forall \sigma. \quad (28)$$

Let $f_{\mu, \zeta}(\sigma)$ and $F_{\mu, \zeta}(\sigma)$ denote respectively the p.d.f. and the c.d.f. of a normal distribution with mean μ and variance ζ^2 . Now, it is clear that condition (28) is satisfied if

$$\frac{\partial^2 \left(\log \left(\frac{f_{\mu, \zeta}(\sigma)}{F_{\mu, \zeta}(\sigma)} \right) \right)}{\partial \mu \partial \sigma} < 0, \forall \sigma, \mu, \zeta.$$

Step 2 Let ϕ and Φ stand for respectively the p.d.f and the c.d.f of the standard normal distribution. Note that

$$f_{\mu, \sigma} = \frac{1}{\sigma \sqrt{2\pi}} e^{-(x-\mu)^2 / (2\zeta^2)} = \frac{1}{\zeta} \phi \left(\frac{x-\mu}{\zeta} \right); F_{\mu, \sigma} = \Phi \left(\frac{x-\mu}{\zeta} \right).$$

Now,

$$\begin{aligned} \frac{\partial^2 \left(\log \left(\frac{f_{\mu, \zeta}(\sigma)}{F_{\mu, \zeta}(\sigma)} \right) \right)}{\partial \mu \partial \sigma} &= \frac{\partial^2 \left(\log \left(\frac{\frac{1}{\zeta} \phi \left(\frac{x-\mu}{\zeta} \right)}{\Phi \left(\frac{x-\mu}{\zeta} \right)} \right) \right)}{\partial \mu \partial x} \\ &= \frac{\partial^2 \left(\log \left(\frac{1}{\zeta} \right) \right)}{\partial \mu \partial x} + \frac{\partial^2 \left(\log \left(\frac{\phi \left(\frac{x-\mu}{\zeta} \right)}{\Phi \left(\frac{x-\mu}{\zeta} \right)} \right) \right)}{\partial \mu \partial x} \\ &= \frac{\partial^2 \left(\log \left(\frac{\phi \left(\frac{x-\mu}{\zeta} \right)}{\Phi \left(\frac{x-\mu}{\zeta} \right)} \right) \right)}{\partial \mu \partial x}. \end{aligned}$$

Now, define a new random variable given by $X = \frac{x-\mu}{\xi}$. Then

$$\begin{aligned} \frac{\partial^2 \left(\log \left(\frac{\phi \left(\frac{x-\mu}{\xi} \right)}{\Phi \left(\frac{x-\mu}{\xi} \right)} \right) \right)}{\partial \mu \partial x} &= \frac{\partial \left(\frac{\partial \left(\log \left(\frac{\phi(X)}{\Phi(X)} \right) \right) \frac{\partial X}{\partial x}}{\partial \mu} \right)}{\partial \mu} \\ &= \frac{\partial \left(\frac{\partial \left(\log \left(\frac{\phi(X)}{\Phi(X)} \right) \right) \frac{1}{\xi}}{\partial \mu} \right)}{\partial \mu} \\ &= \frac{\partial^2 \left(\log \left(\frac{\phi(X)}{\Phi(X)} \right) \right) \frac{1}{\xi} \frac{\partial X}{\partial \mu}}{\partial^2 X} \\ &= - \frac{\partial^2 \left(\log \left(\frac{\phi(X)}{\Phi(X)} \right) \right) \frac{1}{\xi^2}}{\partial^2 X}. \end{aligned}$$

It follows that the sign of $\frac{\partial^2 \left(\log \left(\frac{\phi \left(\frac{x-\mu}{\xi} \right)}{\Phi \left(\frac{x-\mu}{\xi} \right)} \right) \right)}{\partial \mu \partial x}$ depends on the sign of

$$\frac{\partial^2 \left(\log \left(\frac{\phi(X)}{\Phi(X)} \right) \right)}{\partial^2 X}. \quad (29)$$

Step 3 We now study the sign of the expression (29). Note that

$$\frac{\partial^2 \left(\log \left(\frac{\phi(X)}{\Phi(X)} \right) \right)}{\partial^2 X} = \frac{\partial^2 (\log \phi(X))}{\partial^2 X} - \frac{\partial^2 (\log \Phi(X))}{\partial^2 X}.$$

Recall that

$$\begin{aligned} \frac{\partial^2 (\log \phi(X))}{\partial^2 X} &= \frac{\partial^2 \left(\log \left(\frac{1}{\sqrt{2\pi}} e^{-X^2/(2)} \right) \right)}{\partial^2 X} \\ &= -1. \end{aligned}$$

It follows that

$$\begin{aligned} \frac{\partial^2 \left(\log \left(\frac{\phi(X)}{\Phi(X)} \right) \right)}{\partial^2 X} &= -1 - \frac{\partial^2 (\log \Phi(X))}{\partial^2 X} \\ &= -1 - \frac{\partial \left(\frac{\phi(X)}{\Phi(X)} \right)}{\partial X}. \end{aligned}$$

Now, we know two facts about $\frac{\partial \left(\frac{\phi(X)}{\Phi(X)} \right)}{\partial X}$ from the Hayashi (2010) Addendum to Hayashi (2000).

First

$$\frac{\partial^2 \left(\frac{\phi(X)}{\Phi(X)} \right)}{\partial^2 X} > 0,$$

i.e. $\frac{\partial(\log \Phi(X))}{\partial X}$ is increasing in X , given that the ratio $\frac{\phi(X)}{\Phi(X)}$ is convex. Furthermore, $\frac{\phi(X)}{\Phi(X)}$ asymptotes to $-X$, which means that

$$\lim_{X \rightarrow -\infty} \frac{\partial \left(\frac{\phi(X)}{\Phi(X)} \right)}{\partial X} = -1.$$

It follows that

$$\frac{\partial^2 \left(\log \left(\frac{\phi(X)}{\Phi(X)} \right) \right)}{\partial^2 X} > 0, \forall X$$

and that

$$\frac{\partial^2 \left(\log \left(\frac{\phi \left(\frac{x-\mu}{\xi} \right)}{\Phi \left(\frac{x-\mu}{\xi} \right)} \right) \right)}{\partial \mu \partial x} < 0, \forall x, \mu, \xi.$$

This concludes the proof of our Lemma. ■

8.2 Statement and Proof of Lemma 5

$$\frac{\frac{1-F_B(\sigma)}{1-F_A(\sigma)}}{\frac{\partial \left(\frac{1-F_B(\sigma)}{1-F_A(\sigma)} \right)}{\partial \sigma}} > \frac{\frac{f_B(\sigma)}{f_A(\sigma)}}{\frac{\partial \left(\frac{f_B(\sigma)}{f_A(\sigma)} \right)}{\partial \sigma}}, \forall \sigma, \forall \sigma. \quad (30)$$

The condition is satisfied in the following canonical cases.

Lemma 5 a) Suppose that f_B and f_A are two normal distributions with identical variance ξ^2 and means μ_A, μ_B , with $\mu_A < \mu_B$. Then (30) is satisfied.

b) Suppose that f_B and f_A are two linear distributions defined over the same bounded interval and that f_B increases in σ while f_A decreases in σ . Then (30) is satisfied.

We here prove Point a) of the Lemma. Point b) follows similar steps.

$$\frac{\frac{1-F_B(\sigma)}{1-F_A(\sigma)}}{\frac{\partial \left(\frac{1-F_B(\sigma)}{1-F_A(\sigma)} \right)}{\partial \sigma}} > \frac{\frac{f_B(\sigma)}{f_A(\sigma)}}{\frac{\partial \left(\frac{f_B(\sigma)}{f_A(\sigma)} \right)}{\partial \sigma}}, \forall \sigma \Leftrightarrow \frac{\frac{\partial \left(\frac{F_B(\sigma)}{F_A(\sigma)} \right)}{\partial \sigma}}{\frac{F_B(\sigma)}{F_A(\sigma)}} < \frac{\frac{\partial \left(\frac{f_B(\sigma)}{f_A(\sigma)} \right)}{\partial \sigma}}{\frac{f_B(\sigma)}{f_A(\sigma)}}, \forall \sigma \Leftrightarrow \quad (31)$$

$$\frac{\partial \left(\log \left(\frac{1-F_B(\sigma)}{1-F_A(\sigma)} \right) \right)}{\partial \sigma} < \frac{\partial \left(\log \left(\frac{f_B(\sigma)}{f_A(\sigma)} \right) \right)}{\partial \sigma}, \forall \sigma \Leftrightarrow \quad (32)$$

$$\frac{\partial \left(\log \left(\frac{f_A(\sigma)}{1-F_A(\sigma)} \right) \right)}{\partial \sigma} < \frac{\partial \left(\log \left(\frac{f_B(\sigma)}{1-F_B(\sigma)} \right) \right)}{\partial \sigma}, \forall \sigma. \quad (33)$$

The proof follows the same step as the proof of Lemma 3. A change appears in the following step:

$$\begin{aligned} \frac{\partial^2 \left(\log \left(\frac{\phi(X)}{1-\Phi(X)} \right) \right)}{\partial^2 X} &= -1 - \frac{\partial^2 (\log(1 - \Phi(X)))}{\partial^2 X} \\ &= -1 - \frac{\partial \left(-\frac{\phi(X)}{1-\Phi(X)} \right)}{\partial X}. \end{aligned}$$

Using the Hayashi (2010) Addendum to Hayashi (2000), it is then easily shown that it is always true, under our assumptions, that

$$\frac{\partial \left(-\frac{\phi(X)}{1-\Phi(X)} \right)}{\partial X} > -1.$$

Indeed, the function $\frac{\phi(X)}{1-\Phi(X)}$, which is commonly called the inverse Mills ratio, is monotonically increasing in X , convex and asymptotes to X . ■

8.3 Statement and proof of Fact F.1

We here show that if (2) is true, then

$$\frac{\partial \left(\frac{F_B(t_S^1(e))}{F_A(t_S^1(e))} \left(\frac{\frac{1}{2}+e}{\frac{1}{2}-e} \right) \right)}{\partial e} \geq 0. \quad (34)$$

This constitutes Fact F.1.

We revert to the notation $t_S^i(e)$ rather than $t_S^i(Y)$, the two being equivalent, given that any level of e corresponds to a unique value of Y . The above inequality plays a key role in the derivations executed in the next step. Note that

$$\frac{\partial \left(\left(\frac{\frac{1}{2}+e}{\frac{1}{2}-e} \right) \frac{F_B(t_S^2(e))}{F_A(t_S^2(e))} \right)}{\partial e} = \frac{\partial \left(\frac{\frac{1}{2}+e}{\frac{1}{2}-e} \right)}{\partial e} \frac{F_B(t_S^1(e))}{F_A(t_S^1(e))} + \left(\frac{\frac{1}{2}+e}{\frac{1}{2}-e} \right) \frac{\partial \left(\frac{F_B(t_S^1(e))}{F_A(t_S^1(e))} \right)}{\partial e}.$$

Also

$$\left(\frac{\frac{1}{2}+e}{\frac{1}{2}-e} \right) \frac{f_B(t_S^1(e))}{f_A(t_S^1(e))} = \frac{q_S}{1-q_S} \Leftrightarrow \frac{\partial t_S^1(e)}{\partial e} = - \frac{\frac{\partial \left(\frac{\frac{1}{2}+e}{\frac{1}{2}-e} \right)}{\partial e} \frac{f_B(t_S^1(e))}{f_A(t_S^1(e))}}{\left(\frac{\frac{1}{2}+e}{\frac{1}{2}-e} \right) \frac{\partial \left(\frac{f_B(t_S^1(e))}{f_A(t_S^1(e))} \right)}{\partial t_S^1(e)}}.$$

Now, it follows that:

$$\begin{aligned}
\frac{\partial \left(\left(\frac{\frac{1}{2}+e}{\frac{1}{2}-e} \right) \frac{F_B(t_S^1(e))}{F_A(t_S^1(e))} \right)}{\partial e} &= \frac{\partial \left(\frac{\frac{1}{2}+e}{\frac{1}{2}-e} \right) F_B(t_S^1(e))}{\partial e F_A(t_S^1(e))} + \left(\frac{\frac{1}{2}+e}{\frac{1}{2}-e} \right) \frac{\partial \left(\frac{F_B(t_S^1(e))}{F_A(t_S^1(e))} \right)}{\partial t_S^1(e)} \frac{\partial t_S^1(e)}{\partial e} \\
&= \frac{\partial \left(\frac{\frac{1}{2}+e}{\frac{1}{2}-e} \right) F_B(t_S^1(e))}{\partial e F_A(t_S^1(e))} + \left(\frac{\frac{1}{2}+e}{\frac{1}{2}-e} \right) \frac{\partial \left(\frac{F_B(t_S^1(e))}{F_A(t_S^1(e))} \right)}{\partial t_S^1(e)} \left(- \frac{\frac{\partial \left(\frac{\frac{1}{2}+e}{\frac{1}{2}-e} \right) f_B(t_S^1(e))}{\partial e} f_A(t_S^1(e))}{\left(\frac{\frac{1}{2}+e}{\frac{1}{2}-e} \right) \frac{\partial \left(\frac{f_B(t_S^1(e))}{f_A(t_S^1(e))} \right)}{\partial t_S^1(e)}} \right) \\
&= \frac{\partial \left(\frac{\frac{1}{2}+e}{\frac{1}{2}-e} \right)}{\partial e} \left(\frac{F_B(t_S^1(e))}{F_A(t_S^1(e))} - \frac{\partial \left(\frac{F_B(t_S^1(e))}{F_A(t_S^1(e))} \right)}{\partial t_S^1(e)} \frac{f_B(t_S^1(e))}{\frac{\partial \left(\frac{f_B(t_S^1(e))}{f_A(t_S^1(e))} \right)}{\partial t_S^1(e)}} \right).
\end{aligned}$$

Note that $\frac{\partial \left(\frac{\frac{1}{2}+e}{\frac{1}{2}-e} \right)}{\partial e} > 0, \forall e \in (0, \frac{1}{2})$. ■

8.4 Statement and proof of Fact F.2

We here show that

$$\frac{F_B(t_S^1(e)) + q_S (F_B(t_S^2(e)) - F_B(t_S^1(e)))}{F_A(t_S^1(e)) + q_S (F_A(t_S^2(e)) - F_A(t_S^1(e)))} \left(\frac{\frac{1}{2}+e}{\frac{1}{2}-e} \right)$$

is increasing in e . This constitutes Fact F.2.

If we ignore the dependence of $t_S^2(e)$ on e and instead keep it fixed as we change e , we have:

$$\begin{aligned}
& \frac{\partial \left(\frac{(1-q_S)F_B(t_S^1(e)) + q_S F_B(t_S^2(e))}{(1-q_S)F_A(t_S^1(e)) + q_S F_A(t_S^2(e))} \left(\frac{\frac{1}{2}+e}{\frac{1}{2}-e} \right) \right)}{\partial e} \\
&= \frac{\left(\begin{aligned} & \left((1-q_S) \frac{\partial \left(F_B(t_S^1(e)) \left(\frac{\frac{1}{2}+e}{\frac{1}{2}-e} \right) \right)}{\partial e} \right) \left((1-q_S)F_A(t_S^1(e)) + q_S F_A(t_S^2(e)) \right) \\ & - \left(\frac{\frac{1}{2}+e}{\frac{1}{2}-e} \right) \left((1-q_S)F_B(t_S^1(e)) + q_S F_B(t_S^2(e)) \right) \left((1-q_S) \frac{\partial (F_A(t_S^1(e)))}{\partial e} \right) \end{aligned} \right)}{\left((1-q_S)F_A(t_S^1(e)) + q_S F_A(t_S^2(e)) \right)^2} \\
&= \frac{\left(\begin{aligned} & (1-q_S)^2 \left(\frac{\partial \left(F_B(t_S^1(e)) \left(\frac{\frac{1}{2}+e}{\frac{1}{2}-e} \right) \right)}{\partial e} F_A(t_S^1(e)) - \frac{\partial (F_A(t_S^1(e)))}{\partial e} \left(\frac{\frac{1}{2}+e}{\frac{1}{2}-e} \right) F_B(t_S^1(e)) \right) \\ & + (1-q_S)q_S \left(\frac{\partial \left(F_B(t_S^1(e)) \left(\frac{\frac{1}{2}+e}{\frac{1}{2}-e} \right) \right)}{\partial e} F_A(t_S^2(e)) - \frac{\partial (F_A(t_S^1(e)))}{\partial e} \left(\frac{\frac{1}{2}+e}{\frac{1}{2}-e} \right) F_B(t_S^2(e)) \right) \end{aligned} \right)}{\left((1-q_S)F_A(t_S^1(e)) + q_S F_A(t_S^2(e)) \right)^2}.
\end{aligned}$$

Note now that for $T \in \{t_S^1(e), t_S^2(e)\}$:

$$\begin{aligned}
\frac{\partial \left(F_B(t_S^1(e)) \left(\frac{\frac{1}{2}+e}{\frac{1}{2}-e} \right) \right)}{\partial e} F_A(T) - \frac{\partial (F_A(t_S^1(e)))}{\partial e} \left(\frac{\frac{1}{2}+e}{\frac{1}{2}-e} \right) F_B(T) &> 0 \Leftrightarrow \\
\frac{F_B(T)}{F_A(T)} &> \frac{-\frac{\partial \left(F_B(t_S^1(e)) \left(\frac{\frac{1}{2}+e}{\frac{1}{2}-e} \right) \right)}{\partial e}}{-\frac{\partial (F_A(t_S^1(e)))}{\partial e} \left(\frac{\frac{1}{2}+e}{\frac{1}{2}-e} \right)}.
\end{aligned} \tag{35}$$

Now, note that

$$\begin{aligned}
& \frac{\partial \left(F_B(t_S^1(e)) \left(\frac{\frac{1}{2}+e}{\frac{1}{2}-e} \right) \right)}{\partial e} F_A(t_S^1(e)) - \frac{\partial (F_A(t_S^1(e)))}{\partial e} \left(\frac{\frac{1}{2}+e}{\frac{1}{2}-e} \right) F_B(t_S^1(e)) \\
&= \frac{\partial \left(\frac{F_B(t_S^1(Y)) \frac{\frac{1}{2}+e}{\frac{1}{2}-e}}{F_A(t_S^1(Y)) \frac{\frac{1}{2}-e}{\frac{1}{2}+e}} \right)}{\partial e}.
\end{aligned} \tag{36}$$

We know that under condition (2), expression (36) is positive. It follows, given that $\frac{F_B(t_S^2(e))}{F_A(t_S^2(e))} > \frac{F_B(t_S^1(e))}{F_A(t_S^1(e))}$, that if (36) is positive, then (35) is positive as well when setting $T = t_S^2(e)$. In other words, if (2) is satisfied, then if $\tilde{e} > e$, we have now shown that

$$\frac{F_B(t_S^1(e)) + q_S (F_B(t_S^2(e)) - F_B(t_S^1(e)))}{F_A(t_S^1(e)) + q_S (F_A(t_S^2(e)) - F_A(t_S^1(e)))} \left(\frac{\frac{1}{2}+e}{\frac{1}{2}-e} \right) < \frac{F_B(t_S^1(\tilde{e})) + q_S (F_B(t_S^2(e)) - F_B(t_S^1(\tilde{e})))}{F_A(t_S^1(\tilde{e})) + q_S (F_A(t_S^2(e)) - F_A(t_S^1(\tilde{e})))} \left(\frac{\frac{1}{2}+\tilde{e}}{\frac{1}{2}-\tilde{e}} \right).$$

It is furthermore clear that

$$\frac{F_B(t_S^1(\tilde{e})) + q_S (F_B(t_S^2(e)) - F_B(t_S^1(\tilde{e})))}{F_A(t_S^1(\tilde{e})) + q_S (F_A(t_S^2(e)) - F_A(t_S^1(\tilde{e})))} \left(\frac{1}{2} + \tilde{e} \right) < \frac{F_B(t_S^1(\tilde{e})) + q_S (F_B(t_S^2(\tilde{e})) - F_B(t_S^1(\tilde{e})))}{F_A(t_S^1(\tilde{e})) + q_S (F_A(t_S^2(\tilde{e})) - F_A(t_S^1(\tilde{e})))} \left(\frac{1}{2} + \tilde{e} \right).$$

We may thus conclude that

$$\frac{F_B(t_S^1(e)) + q_S (F_B(t_S^2(e)) - F_B(t_S^1(e)))}{F_A(t_S^1(e)) + q_S (F_A(t_S^2(e)) - F_A(t_S^1(e)))} \left(\frac{1}{2} + e \right)$$

is increasing in e . ■

8.5 Statement an proof of Fact F.3

We here show that

$$\frac{\partial \left(r_l(e) \frac{F_B(t_S^2(e))}{F_A(t_S^2(e))} \right)}{\partial e} < 0.$$

This constitutes Fact F.3.

Note that

$$\frac{\partial \left(r_l(e) \frac{F_B(t_S^2(e))}{F_A(t_S^2(e))} \right)}{\partial e} = \frac{\partial r_l(e)}{\partial e} \frac{F_B(t_S^2(e))}{F_A(t_S^2(e))} + r_l(e) \frac{\partial \left(\frac{F_B(t_S^2(e))}{F_A(t_S^2(e))} \right)}{\partial e}.$$

Note that

$$r_l(e) \frac{f_B(t_S^2(e))}{f_A(t_S^2(e))} = \frac{q_S}{1 - q_S} \Leftrightarrow \frac{\partial t_S^2(e)}{\partial e} = - \frac{\frac{\partial r_l(e)}{\partial e} \frac{f_B(t_S^2(e))}{f_A(t_S^2(e))}}{r_l(e) \frac{\partial \left(\frac{f_B(t_S^2(e))}{f_A(t_S^2(e))} \right)}{\partial t_S^2(e)}}$$

Now, it follows that:

$$\begin{aligned} \frac{\partial \left(r_l(e) \frac{F_B(t_S^2(e))}{F_A(t_S^2(e))} \right)}{\partial e} &= \frac{\partial r_l(e)}{\partial e} \frac{F_B(t_S^2(e))}{F_A(t_S^2(e))} + r_l(e) \frac{\partial \left(\frac{F_B(t_S^2(e))}{F_A(t_S^2(e))} \right)}{\partial t_S^2(e)} \frac{\partial t_S^2(e)}{\partial e} \\ &= \frac{\partial r_l(e)}{\partial e} \frac{F_B(t_S^2(e))}{F_A(t_S^2(e))} + r_l(e) \frac{\partial \left(\frac{F_B(t_S^2(e))}{F_A(t_S^2(e))} \right)}{\partial t_S^2(e)} \left(- \frac{\frac{\partial r_l(e)}{\partial e} \frac{f_B(t_S^2(e))}{f_A(t_S^2(e))}}{r_l(e) \frac{\partial \left(\frac{f_B(t_S^2(e))}{f_A(t_S^2(e))} \right)}{\partial t_S^2(e)}} \right) \\ &= \underbrace{\frac{\partial r_l(e)}{\partial e}}_{<0} \underbrace{\left(\frac{F_B(t_S^2(e))}{F_A(t_S^2(e))} - \frac{\partial \left(\frac{F_B(t_S^2(e))}{F_A(t_S^2(e))} \right)}{\partial t_S^2(e)} \frac{f_B(t_S^2(e))}{f_A(t_S^2(e))} \right)}_{>0 \text{ by Lemma 5}} \end{aligned}$$

Note that $\frac{\partial r_l(e)}{\partial e} < 0, \forall e \in (0, \frac{1}{2})$. ■

8.6 Statement and proof of Fact F.4

We here show that

$$\frac{\partial \left(r_l(e) \frac{1-F_B(t_S^2(e))}{1-F_A(t_S^2(e))} \right)}{\partial e} < 0$$

This constitutes Fact F.4.

$$\begin{aligned} \frac{\partial \left(r_l(e) \frac{1-F_B(t_S^2(e))}{1-F_A(t_S^2(e))} \right)}{\partial e} &= \frac{\partial r_l(e)}{\partial e} \frac{1-F_B(t_S^2(e))}{1-F_A(t_S^2(e))} + r_l(e) \frac{\partial \left(\frac{1-F_B(t_S^2(e))}{1-F_A(t_S^2(e))} \right)}{\partial t_S^2(e)} \frac{\partial t_S^2(e)}{\partial e} \\ &= \frac{\partial r_l(e)}{\partial e} \frac{1-F_B(t_S^2(e))}{1-F_A(t_S^2(e))} + r_l(e) \frac{\partial \left(\frac{1-F_B(t_S^2(e))}{1-F_A(t_S^2(e))} \right)}{\partial t_S^2(e)} \left(-\frac{\frac{\partial r_l(e)}{\partial e} \frac{f_B(t_S^2(e))}{f_A(t_S^2(e))}}{r_l(e) \frac{\partial \left(\frac{f_B(t_S^2(e))}{f_A(t_S^2(e))} \right)}{\partial t_S^2(e)}} \right) \\ &= \underbrace{\frac{\partial r_l(e)}{\partial e}}_{<0} \underbrace{\left(\frac{1-F_B(t_S^2(e))}{1-F_A(t_S^2(e))} - \frac{\partial \left(\frac{1-F_B(t_S^2(e))}{1-F_A(t_S^2(e))} \right)}{\partial t_S^2(e)} \frac{\frac{f_B(t_S^2(e))}{f_A(t_S^2(e))}}{\frac{\partial \left(\frac{f_B(t_S^2(e))}{f_A(t_S^2(e))} \right)}{\partial t_S^2(e)}} \right)}_{<0 \text{ by Lemma 5}} \end{aligned}$$

■

9 Appendix E: Proof of Proposition 3

Point a) Suppose an influential equilibrium that is not S -optimal. In a given influential equilibrium E , let C_j^E denote the set of equilibrium messages that give rise to action $j \in \{a, b, h\}$ by R , where h refers to the optimal hedging strategy in which R plays action a with probability q_R . In what follows, we slightly abuse notation by dropping the explicit reference to the equilibrium under consideration and simply writing C_j . Influential equilibria can be gathered into four types. Either, in a given equilibrium, C_a, C_b and C_h are non-empty (call this Case 1). Or C_a, C_b are non-empty and C_h is empty (Case 2). Or C_a and C_h are non-empty while C_b is empty (Case 3). Or C_b and C_h are non-empty while C_a is empty (Case 4).

In Cases 1 and 2, the equilibrium must implement S' optimal decision rule, as S otherwise trivially has a strict incentive to deviate at some information set.

Case 3 may correspond to an equilibrium scenario. In such a case, S must behave as follows in order to have no strict incentive to deviate. If $s < t_S^1$, he emits for sure a message belonging to C_a . If $s \in [t_S^1, t_S^2]$, he emits a message belonging to C_a with probability $\frac{1-q_S}{1-q_R}$ and a message belonging to C_h with the remaining probability. If $s > t_S^2$, he emits a message belonging to C_h for sure.

Case 4 may also correspond to an equilibrium scenario. In order for S not to have a strict incentive to deviate, it must be that S issues a message belonging to C_h whenever $s < t_S^2$ and issues a message belonging to C_b when $s > t_S^2$.

Point b) Suppose there exists an equilibrium E implementing the decision rule D_1 . This equilibrium defines two non-empty sets C_b and C_h , where the latter are defined as in Point a) above. Suppose now a putative equilibrium \hat{E} in which the communication strategy is given as follows. At every information at which S sends a message belonging to C_h in E , S now sends m_1 . Furthermore, at every information set at which S sends a message belonging to C_b in E , S now sends message m_2 . It is trivially true that if E is an equilibrium, then \hat{E} is also an equilibrium.

Point c) Suppose there exists an equilibrium E implementing the decision rule D_2 . This equilibrium defines two and only two non-empty sets C_a and C_h , where the latter are defined as in Point a) above. Suppose now a putative equilibrium \hat{E} in which the communication strategy is given as follows. At every information at which S sends a message belonging to C_a in E , S now sends m_1 . Furthermore, at every information set at which S sends a message belonging to C_h in E , S now sends message m_2 . It is trivially true that if E is an equilibrium, then \hat{E} is also an equilibrium.

Point d) Step 1 An equilibrium implementing decision rule D_1 exists iff:

$$\frac{P_l(B)}{1 - P_l(B)} \frac{F_B(t_S^2)}{F_A(t_S^2)} < q_R \leq \frac{P_h(B)}{1 - P_h(B)} \frac{F_B(t_S^2)}{F_A(t_S^2)}$$

and

$$q_R \leq \frac{P_l(B)}{1 - P_l(B)} \frac{1 - F_B(t_S^2)}{1 - F_A(t_S^2)}.$$

Clearly, note that

$$\frac{P_l(B)}{1 - P_l(B)} \frac{F_B(t_S^2)}{F_A(t_S^2)} < q_S < \frac{P_l(B)}{1 - P_l(B)} \frac{1 - F_B(t_S^2)}{1 - F_A(t_S^2)}.$$

Furthermore, note that if e is sufficiently small,

$$q_S > \frac{P_h(B)}{1 - P_h(B)} \frac{F_B(t_S^2)}{F_A(t_S^2)}.$$

Step 2 Define

$$G(q_S, q_R) = \frac{(F_B(1) - F_B(t_S^2)) + \left(\frac{1-q_S}{1-q_R}\right) (F_B(t_S^2) - F_B(t_S^1))}{(F_A(1) - F_A(t_S^2)) + \left(\frac{1-q_S}{1-q_R}\right) (F_A(t_S^2) - F_A(t_S^1))}.$$

An equilibrium implementing decision rule D_2 exists iff:

$$\frac{P_h(B)}{1 - P_h(B)} \frac{F_B(t_S^1) + \left(\frac{q_S - q_R}{1 - q_R}\right) (F_B(t_S^2) - F_B(t_S^1))}{F_A(t_S^1) + \left(\frac{q_S - q_R}{1 - q_R}\right) (F_A(t_S^2) - F_A(t_S^1))} < q_R,$$

and

$$\frac{P_l(B)}{1 - P_l(B)} G(q_S, q_R) < q_R < \frac{P_h(B)}{1 - P_h(B)} G(q_S, q_R).$$

Note that

$$\frac{P_h(B)}{1 - P_h(B)} G(q_S, q_R) > q_S.$$

Now, note that for e sufficiently small, clearly

$$\frac{P_l(B)}{1 - P_l(B)} G(q_S, q_S) > q_S.$$

■

10 Appendix F: Proof of Propositions 4 and 5

10.1 Proof of Proposition 4

Step 1 As to Point i.a, note that for $e \leq e_1(q_S)$, it is always true that

$$\underline{q}_R(q_S, e, 3) = \Psi(t_S^1(e), q_S, e).$$

and recall that $\Psi(t_S^1(e), q_S, e)$ is increasing in e .

Step 2 As to Point i.b, note that for $e \leq e_3(q_S)$, it is always true that

$$\underline{q}_R(q_S, e, 2) = \Psi(t_S^1(e), q_S, e).$$

Note also that if $e_2(q_S) < e_3(q_S)$, then for $e \leq e_2(q_S)$

$$\bar{q}_R(q_S, e, 2) = q_S,$$

while for $e \in (e_2(q_S), e_3(q_S)]$

$$\bar{q}_R(q_S, e, 2) = P_l(B \mid m_2, t_S^1(e), q_R, q_S, e).$$

Furthermore, $P_l(B \mid m_2, t_S^1(e), q_R, q_S, e)$ is decreasing in e .

Step 3 This proves Point ii. Recall that an equilibrium implementing decision rule D_1 exists iff:

$$\frac{P_l(B)}{1 - P_l(B)} \frac{F_B(t_S^2)}{F_A(t_S^2)} < q_R \leq \frac{P_h(B)}{1 - P_h(B)} \frac{F_B(t_S^2)}{F_A(t_S^2)}$$

and

$$q_R \leq \frac{P_l(B)}{1 - P_l(B)} \frac{1 - F_B(t_S^2)}{1 - F_A(t_S^2)}.$$

Now, note the following three facts. First, it is immediate that

$$\frac{\partial \left(\frac{P_h(B)}{1 - P_h(B)} \frac{F_B(t_S^2)}{F_A(t_S^2)} \right)}{\partial e} > 0.$$

Second, Fact F3. states that

$$\frac{\partial \left(\frac{P_l(B)}{1 - P_l(B)} \frac{F_B(t_S^2)}{F_A(t_S^2)} \right)}{\partial e} < 0.$$

Third, Fact F4. states that

$$\frac{\partial \left(\frac{P_l(B)}{1 - P_l(B)} \frac{1 - F_B(t_S^2(e))}{1 - F_A(t_S^2(e))} \right)}{\partial e} > 0.$$

■

10.2 Proof of Proposition 5

Step 1 The proof of point a) follows trivially from proposition 4 and is therefore omitted.

Step 2 The next steps prove Point b). Define

$$\Pi_0(e, q_i, j) = -P_j^e(B)q_i.$$

$$\Pi_1(e, q_i, q_R, j) = -(1 - P_j^e(B)) [F_A(t_S^2(e))(1 - q_R) + (1 - F_A(t_S^2(e)))] q_i - P_j^e(B)F_B(t_S^2(e))q_R(1 - q_i).$$

In order to prove that agent i unilaterally favours the equilibrium implementing decision rule D_1 under positive ambiguity e to the babbling equilibrium under no-ambiguity, we simply need to establish that for each $j \in \{l, h\}$, given e ,

$$\Pi_0(0, q_i, h) = \Pi_0(0, q_i, l) < \Pi_1(e, q_i, q_R, j).$$

Step 3 First, clearly, for any $q_R < q_S$,

$$\Pi_1(0, q_S, q_R, l) - \Pi_0(0, q_S, l) =: \Delta(0, q_S, q_R, l) > 0.$$

Now, clearly, the expression

$$|\Pi_1(0, q_S, q_R, l) - \Pi_1(e, q_S, q_R, l)|$$

is continuous in e and tends to 0 as e tends to 0. It follows for every $q_R < q_S$, there is an $e^*(q_R) > 0$ s.t. for any $e < e^*(q_R)$

$$\Pi_0(0, q_S, l) < \Pi_1(e, q_S, q_R, l).$$

We furthermore know that $\Pi_1(e, q_S, q_R, l)$ is continuous in q_R , for any e, q_S . It follows that we may find some $e_l > 0$ s.t. for any $e \in (0, e_l)$, there is some $q_R^l(e, q_S) < \underline{q}_R(q_S, e, 3)$ s.t. for $q_R \in [q_R^l(e, q_S), \underline{q}_R(q_S, e, 3)]$,

$$\Pi_1(e, q_S, q_R, l) > \Pi_0(0, q_S, l).$$

Step 4 We focus in the next steps on identifying conditions under which $\Pi_0(0, q_S, h) < \Pi_1(e, q_S, q_R, h)$. We now establish two facts. The first fact is that for $e \in (0, \frac{1}{2})$,

$$\Pi_0(0, q_S, h) < \Pi_0(e, q_S, h).$$

The second fact follows. By definition, given that $\lim_{e \rightarrow 0} t_S^1(e) = \lim_{e \rightarrow 0} t_S^2(e)$, there exists $e_h > 0$ s.t. for $e \in (0, e_h)$,

$$\Pi_1(e, q_S, \underline{q}_R(q_S, e, 3), h) > \Pi_0(e, q_S, h).$$

We furthermore know that $\Pi_1(e, q_S, q_R, h)$ is continuous in q_R , for any e, q_S . This immediately implies that for every $e \in (0, e_h)$, there is some $q_R^h(e, q_S) < \underline{q}_R(q_S, e, 3)$ s.t. for $q_R \in [q_R^h(e, q_S), \underline{q}_R(q_S, e, 3)]$

$$\Pi_1(e, q_S, q_R, l) > \Pi_0(e, q_S, h) > \Pi_0(0, q_S, h).$$

Step 5 We know from Proposition 4 that for any e , there exists $q_R^1(e, q_S) < \underline{q}_R(q_S, e, 3)$ s.t. for $q_R \in [q_R^1(e, q_S), \underline{q}_R(q_S, e, 3)]$, there exists an equilibrium implementing decision rule D_1 .

Step 6 It follows from preceding steps that for $e \in (0, \min \{e_l, e_h\})$, there is some

$$\hat{q}_R(e, q_S) = \max \left\{ q_R^1(e, q_S), q_R^l(e, q_S), q_R^h(e, q_S) \right\} < \underline{q}_R(q_S, e, 3)$$

s.t for $q_R \in [\hat{q}_R(e, q_S), \underline{q}_R(q_S, e, 3)]$, there exists an equilibrium implementing decision rule D_1 and furthermore

$$\min \{ \Pi_1(e, q_S, q_R, l), \Pi_1(e, q_S, q_R, h) \} > \Pi_0(0, q_S, h).$$

■

11 Appendix G: Proof of Proposition 6

Step 1 By definition, the monotone 3-partitions E_3 equilibrium exists iff

$$\frac{P(m_1 | B, E_3)}{P(m_1 | A, E_3)} < Q_1(q_R) \quad (37)$$

and

$$\frac{P(m_2 | B, E_3)}{P(m_2 | A, E_3)} \geq Q_2(q_R). \quad (38)$$

Step 2 Note that for a given q_S

$$\frac{P(m_1 | B, E_3)}{P(m_1 | A, E_3)} < \frac{P(m_2 | B, E_3)}{P(m_2 | A, E_3)}$$

To see this, note first that by the MLRP property,

$$\frac{\int_{t_0^3}^{t_1^3} f_B(\sigma) d\sigma}{\int_{t_0^3}^{t_1^3} f_A(\sigma) d\sigma} < \frac{\int_{t_2^3}^{t_3^3} f_B(\sigma) d\sigma}{\int_{t_2^3}^{t_3^3} f_A(\sigma) d\sigma}$$

and note secondly that

$$\frac{\int_{t_1^3}^{t_2^3} \left(\frac{\beta_S(\sigma) - \beta_S(t_1^3)}{\beta_S(t_2^3) - \beta_S(t_1^3)} \right) f_B(\sigma) d\sigma}{\int_{t_1^3}^{t_2^3} \left(\frac{\beta_S(\sigma) - \beta_S(t_1^3)}{\beta_S(t_2^3) - \beta_S(t_1^3)} \right) f_A(\sigma) d\sigma} < \frac{\int_{t_1^3}^{t_2^3} \left(\frac{\beta_S(t_2^3) - \beta_S(\sigma)}{\beta_S(t_2^3) - \beta_S(t_1^3)} \right) f_B(\sigma) d\sigma}{\int_{t_1^3}^{t_2^3} \left(\frac{\beta_S(t_2^3) - \beta_S(\sigma)}{\beta_S(t_2^3) - \beta_S(t_1^3)} \right) f_A(\sigma) d\sigma}$$

The latter inequality follows directly from Theorem 1 in Wijsman (1985) given that the ratios $\frac{f_B(\sigma)}{f_A(\sigma)}$ and

$$\frac{\left(\frac{\beta_S(\sigma) - \beta_S(t_1^3)}{\beta_S(t_2^3) - \beta_S(t_1^3)} \right)}{\left(\frac{\beta_S(t_2^3) - \beta_S(\sigma)}{\beta_S(t_2^3) - \beta_S(t_1^3)} \right)}$$

are both monotonically increasing in σ , for $\sigma \in [t_1^3, t_2^3]$. Note also that

$$\frac{\partial Q_j(q_i)}{\partial q_i} \geq 0, \forall i \in \{S, R\}, \forall j \in \{1, 2\}.$$

Step 3 It follows from the facts collected in step 2 that

$$\frac{P(m_1 | B, E_3)}{P(m_1 | A, E_3)} \geq Q_1(q_S) \Rightarrow \frac{P(m_1 | B, E_3)}{P(m_1 | A, E_3)} > Q_1(q_R).$$

Step 4 Given that

$$\frac{P(m_1 | B, E_3)}{P(m_1 | A, E_3)} \leq Q_1(q_S), \quad (39)$$

it follows that there is some $\underline{q}_R^3(q_S) < q_S$ s.t. $\frac{P(m_1 | B, E_3)}{P(m_1 | A, E_3)} = Q_1(\underline{q}_R^3(q_S))$. This ends the proof of Point a.

Step 5 This proves Point b. Note that $\frac{P(m_2 | B, E_3)}{P(m_2 | A, E_3)}$ may be larger or smaller than $Q_2(q_S)$. If $\frac{P(m_2 | B, E_3)}{P(m_2 | A, E_3)} \geq Q_2(q_S)$, it follows that $\frac{P(m_2 | B, E_3)}{P(m_2 | A, E_3)} > Q_2(q_R), \forall q_R < q_S$, so that $\bar{q}_R^3(q_S) = q_S$. On the other hand, if $\frac{P(m_2 | B, E_3)}{P(m_2 | A, E_3)} < Q_2(q_S)$, it follows immediately that $\frac{P(m_2 | B, E_3)}{P(m_2 | A, E_3)} = Q_2(\bar{q}_R^3(q_S))$ and that $\bar{q}_R^3(q_S) < q_S$. ■

12 Appendix H: proof of Proposition 7

Step 1 The monotone 4-partitions E_4 equilibrium exists iff

$$\frac{P(m_1 | B, E_4(t_2^4))}{P(m_1 | A, E_4(t_2^4))} \leq Q_1(q_R) < Q_1(q_S) \quad (40)$$

and

$$\frac{P(m_3 | B, E_4(t_2^4))}{P(m_3 | A, E_4(t_2^4))} \geq Q_2(q_R) \quad (41)$$

and

$$\beta_R \left(\frac{P(m_2 | B, E_4, t_2^4)}{P(m_2 | A, E_4, t_2^4)} \right) = \beta_S \left(\frac{f_B(t_2^4)}{f_A(t_2^4)} \right). \quad (42)$$

Note that the inequality $Q_1(q_R) < Q_1(q_S)$ holds by definition.

Step 2 This step establishes simple comparative statics properties of key likelihood ratios. It can be shown, using Theorem 1 in Wijsman (1985), that

$$\frac{\partial \left(\frac{P(m_i | B, E_4(t_2^4))}{P(m_i | A, E_4(t_2^4))} \right)}{\partial t_2^4} > 0, \forall t_2^4 \in [t_1^4, t_3^4], \forall i \in \{1, 2, 3\}. \quad (43)$$

Note also that

$$\frac{P(m_1 | B, E_4(t_3^4))}{P(m_1 | A, E_4(t_3^4))} = \frac{P(m_1 | B, E_3)}{P(m_1 | A, E_3)}; \quad \frac{P(m_3 | B, E_4(t_1^4))}{P(m_3 | A, E_4(t_1^4))} = \frac{P(m_2 | B, E_3)}{P(m_2 | A, E_3)}.$$

Finally, for any $t_2^4 \in [t_1^4, t_3^4]$, by Theorem 1 in Wijsman (1985)

$$\frac{P(m_1 | B, E_4(t_2^4))}{P(m_1 | A, E_4(t_2^4))} < \frac{P(m_2 | B, E_4(t_2^4))}{P(m_2 | A, E_4(t_2^4))} < \frac{P(m_3 | B, E_4(t_2^4))}{P(m_3 | A, E_4(t_2^4))}.$$

Step 3 This step establishes key properties of the functions β_R and β_S . Given that $\beta_R(\cdot, q_R)$ is increasing in its first argument, it follows from (43) that

$$\frac{\partial \beta_R \left(\frac{P(m_2 | B, E_4(t_2^4))}{P(m_2 | A, E_4(t_2^4))}, q_R \right)}{\partial t_2^4} > 0, \quad \forall t_2^4 \in [t_1^4, t_3^4].$$

Recall that

$$\frac{\partial \beta_S \left(\frac{f_B(t_2^4)}{f_A(t_2^4)}, q_S \right)}{\partial t_2^4} > 0, \quad \forall t_2^4 \in [t_1^4, t_3^4]; \quad \beta_S \left(\frac{f_B(t_1^4)}{f_A(t_1^4)}, q_S \right) = 0; \quad \beta_S \left(\frac{f_B(t_3^4)}{f_A(t_3^4)}, q_S \right) = 1.$$

Recall also that $\forall t_2^4 \in [t_1^4, t_3^4], \forall q_R \in (0, 1)$

$$\frac{\partial \beta_R \left(\frac{P(m_2 | B, E_4(t_2^4))}{P(m_2 | A, E_4(t_2^4))}, q_R \right)}{\partial q_R} \leq 0.$$

It follows that there is a $q_R(q_S) < q_S$ s.t. for $q_R > q_R(q_S)$,

$$\beta_R \left(\frac{P(m_2 | B, E_4(t_3^4))}{P(m_2 | A, E_4(t_3^4))}, q_R \right) < 1.$$

while for $q_R \leq q_R(q_S)$, the inequality is replaced by an equality. It is trivially seen that $\underline{q}_R^3(q_S) < q_R(q_S) < \bar{q}_R^3(q_S)$. This follows from the fact that

$$\frac{P(m_1 | B, E_3)}{P(m_1 | A, E_3)} < \frac{P(m_2 | B, E_4(t_3^4))}{P(m_2 | A, E_4(t_3^4))} < \frac{P(m_2 | B, E_3)}{P(m_2 | A, E_3)} < \frac{P(m_3 | B, E_4(t_3^4))}{P(m_3 | A, E_4(t_3^4))}.$$

We may now conclude that there always exists some $\tilde{t}_2^4 \in [t_1^4, t_3^4]$ s.t.

$$\beta_R \left(\frac{P(m_2 | B, E_4(\tilde{t}_2^4))}{P(m_2 | A, E_4(\tilde{t}_2^4))}, q_R \right) = \beta_S \left(\frac{f_B(\tilde{t}_2^4)}{f_A(\tilde{t}_2^4)}, q_S \right). \quad (44)$$

The latter statement may be refined as follows. There exists some $q_R(q_S) < q_S$ s.t. for $q_R > q_R(q_S)$, there exists some $\tilde{t}_2^4 \in [t_1^4, t_3^4]$ s.t. the above (44) holds. For $q_R \leq q_R(q_S)$, (44) is guaranteed to hold at $\tilde{t}_2^4 = t_3^4$.

Step 4 This step and the next step establish properties of $\bar{q}_R^4(q_S)$. Suppose that $q_R > q_R(q_S)$. We know by step 3 that there exists a $t_2^4 \in [t_1^4, t_3^4]$ s.t. $\beta_R \left(\frac{P(m_2|B, E_4(t_2^4))}{P(m_2|A, E_4(t_2^4))}, q_R \right) = \beta_S \left(\frac{f_B(t_2^4)}{f_A(t_2^4)}, q_S \right)$. Suppose furthermore that q_S is s.t.

$$\frac{P(m_2|B, E_3)}{P(m_2|A, E_3)} \geq Q_2(q_S), \quad (45)$$

so that $\bar{q}_R^3(q_S) = q_S$. In a putative monotone 4-partitions equilibrium given by $\tilde{t}_2^4 \neq t_3^4$ s.t. (44) holds, it is true by step 2 that:

$$\left(\frac{P(m_1|B, E_4(\tilde{t}_2^4))}{P(m_1|A, E_4(\tilde{t}_2^4))} < \frac{P(m_1|B, E_3)}{P(m_1|A, E_3)} \right) \cap \left(\frac{P(m_3|B, E_4(\tilde{t}_2^4))}{P(m_3|A, E_4(\tilde{t}_2^4))} > \frac{P(m_2|B, E_3)}{P(m_2|A, E_3)} \right). \quad (46)$$

It follows that for any q_R s.t. $q_R(q_S) \leq q_R \leq \bar{q}_R^3(q_S) = q_S$,

$$\frac{P(m_1|B, E_4(\tilde{t}_2^4))}{P(m_1|A, E_4(\tilde{t}_2^4))} \leq Q_1(q_R) < Q_2(q_R) \leq \frac{P(m_3|B, E_4(\tilde{t}_2^4))}{P(m_3|A, E_4(\tilde{t}_2^4))}. \quad (47)$$

We have now proven that if (45) holds, there exists a 4-partitions equilibrium for any q_R s.t. $q_R(q_S) \leq q_R \leq \bar{q}_R^3(q_S) = q_S$.

Step 5 Suppose that $q_R > q_R(q_S)$. Suppose now that q_S is s.t.

$$\frac{P(m_2|B, E_3)}{P(m_2|A, E_3)} < Q_2(q_S),$$

so that $\bar{q}_R^3(q_S) < q_S$. For any q_R s.t. $q_R(q_S) \leq q_R \leq \bar{q}_R^3(q_S)$, we know that there exists a $\tilde{t}_2^4 \in [t_1^4, t_3^4]$ s.t. (44) holds. For such a \tilde{t}_2^4 , (47) holds as well. It follows that there exists a monotone 4-partitions equilibrium for any q_R s.t. $q_R(q_S) \leq q_R \leq \bar{q}_R^3(q_S)$.

We now focus on values of q_R s.t. $q_R > \bar{q}_R^3(q_S)$, in order to prove that $\bar{q}_R^4(q_S) > \bar{q}_R^3(q_S)$. We know by step 3 that there exists $t_2^4 \in [t_1^4, t_3^4]$ s.t.

$$\beta_R \left(\frac{P(m_2|B, E_4(t_2^4))}{P(m_2|A, E_4(t_2^4))}, \bar{q}_R^3(q_S) \right) = \beta_S \left(\frac{f_B(t_2^4)}{f_A(t_2^4)}, q_S \right).$$

This implies that there exists some $\varepsilon^* > 0$ s.t for any $\varepsilon \in (0, \varepsilon^*]$, there exists a $t_2^4(\varepsilon) \in [t_1^4, t_3^4]$ s.t.

$$\beta_R \left(\frac{P(m_2|B, E_4(t_2^4(\varepsilon)))}{P(m_2|A, E_4(t_2^4(\varepsilon)))}, \bar{q}_R^3(q_S) + \varepsilon \right) = \beta_S \left(\frac{f_B(t_2^4(\varepsilon))}{f_A(t_2^4(\varepsilon))}, q_S \right).$$

For any $\varepsilon \in (0, \varepsilon^*]$, clearly

$$\frac{P(m_3 | B, E_4(t_2^4(\varepsilon)))}{P(m_3 | A, E_4(t_2^4(\varepsilon)))} > \frac{P(m_2 | B, E_3)}{P(m_2 | A, E_3)}.$$

It also clear, given that $\frac{\partial \beta_R(\cdot, q_R)}{\partial q_R} < 0$, that

$$\frac{\partial t_2^4(\varepsilon)}{\partial \varepsilon} < 0; \quad \frac{\partial \left(\frac{P(m_3 | B, E_4(t_2^4(\varepsilon)))}{P(m_3 | A, E_4(t_2^4(\varepsilon)))} \right)}{\partial \varepsilon} < 0.$$

We know furthermore from the proof of Proposition 6 that

$$Q_2(\bar{q}_R^3(q_S)) = \frac{P(m_2 | B, E_3)}{P(m_2 | A, E_3)}.$$

Using the fact that $\frac{\partial Q_2(q_R)}{\partial q_R} > 0, \forall q_R$, it follows that there is some $\varepsilon^{**} \in (0, \varepsilon^*)$ s.t.

$$\begin{aligned} Q_2(\bar{q}_R^3(q_S) + \varepsilon^{**}) &= \frac{P(m_3 | B, E_4(t_2^4(\varepsilon^{**})))}{P(m_3 | A, E_4(t_2^4(\varepsilon^{**})))}, \\ Q_2(\bar{q}_R^3(q_S) + \varepsilon) &< \frac{P(m_3 | B, E_4(t_2^4(\varepsilon^{**})))}{P(m_3 | A, E_4(t_2^4(\varepsilon^{**})))}, \forall \varepsilon \in (0, \varepsilon^{**}). \end{aligned}$$

It follows that for any $\varepsilon \in (0, \varepsilon^{**})$

$$\frac{P(m_3 | B, E_4(t_2^4(\varepsilon)))}{P(m_3 | A, E_4(t_2^4(\varepsilon)))} > \frac{P(m_3 | B, E_4(t_2^4(\varepsilon^{**})))}{P(m_3 | A, E_4(t_2^4(\varepsilon^{**})))} > Q_2(\bar{q}_R^3(q_S) + \varepsilon).$$

Furthermore, recall that it is trivially true that for any $\varepsilon \in (0, \varepsilon^{**})$

$$\frac{P(m_1 | B, E_4(t_2^4(\varepsilon)))}{P(m_1 | A, E_4(t_2^4(\varepsilon)))} < \frac{P(m_1 | B, E_3)}{P(m_1 | A, E_3)} \leq Q_1(\bar{q}_R^3(q_S)) < Q_1(\bar{q}_R^3(q_S) + \varepsilon).$$

It follows that there is some threshold $\bar{q}_R^4(q_S)$ satisfying $\bar{q}_R^4(q_S) > \bar{q}_R^3(q_S)$ s.t. for any q_R s.t. $\bar{q}_R^3(q_S) \leq q_R \leq \bar{q}_R^4(q_S)$.

Step 6 This step establishes properties of $q_R^4(q_S)$. For any q_R s.t. $\bar{q}_R^3(q_S) \leq q_R \leq q_R(q_S)$, we know that $\beta_R \left(\frac{P(m_2 | B, E_4(t_3^4))}{P(m_2 | A, E_4(t_3^4))}, q_R \right) = \beta_S \left(\frac{f_B(t_3^4)}{f_A(t_3^4)}, q_S \right)$. Note that

$$\frac{P(m_1 | B, E_4(t_3^4))}{P(m_1 | A, E_4(t_3^4))} = \frac{P(m_1 | B, E_3)}{P(m_1 | A, E_3)} \cap \frac{P(m_3 | B, E_4(t_3^4))}{P(m_3 | A, E_4(t_3^4))} > \frac{P(m_2 | B, E_3)}{P(m_2 | A, E_3)}. \quad (48)$$

It follows that for any q_R s.t. $\underline{q}_R^3(q_S) \leq q_R \leq q_R(q_S)$, (47) trivially holds for $\tilde{t}_2^4 = t_3^4$ so that there exists a monotone 4-partitions equilibrium. We now focus on values of q_R s.t. $q_R < \underline{q}_R^3(q_S)$. Suppose that there exists no $t_2^4 \in [t_1^4, t_3^4]$ s.t.

$$\beta_R \left(\frac{P(m_2 | B, E_4(t_2^4))}{P(m_2 | A, E_4(t_2^4))}, \underline{q}_R^3(q_S) \right) = \beta_S \left(\frac{f_B(t_2^4)}{f_A(t_2^4)}, q_S \right). \quad (49)$$

Then, it follows that for any $q_R < \underline{q}_R^3(q_S)$, there exist no 4-partitions equilibrium. Suppose now instead that there exists a $t_2^4 \in [t_1^4, t_3^4]$ s.t.(49) holds. It follows that there is some $\varepsilon^* > 0$ s.t for any $\varepsilon \in (0, \varepsilon^*]$, there exists a $t_2^4(\varepsilon) \in [t_1^4, t_3^4]$ s.t.

$$\beta_R \left(\frac{P(m_2 | B, E_4(t_2^4(\varepsilon)))}{P(m_2 | A, E_4(t_2^4(\varepsilon)))}, \underline{q}_R^3(q_S) - \varepsilon \right) = \beta_S \left(\frac{f_B(t_2^4(\varepsilon))}{f_A(t_2^4(\varepsilon))}, q_S \right).$$

Now, for any $\varepsilon \in (0, \varepsilon^*)$, we know from step 2 that

$$\frac{P(m_1 | B, E_4(t_2^4(\varepsilon)))}{P(m_1 | A, E_4(t_2^4(\varepsilon)))} < \frac{P(m_1 | B, E_3)}{P(m_1 | A, E_3)}.$$

It is furthermore clear, given that $\frac{\partial \beta_R(\cdot, q_R)}{\partial q_R} < 0$, that

$$\frac{\partial t_2^4(\varepsilon)}{\partial \varepsilon} > 0; \quad \frac{\partial \left(\frac{P(m_1 | B, E_4(t_2^4(\varepsilon)))}{P(m_1 | A, E_4(t_2^4(\varepsilon)))} \right)}{\partial \varepsilon} > 0.$$

We also know from the proof of Proposition 6 that by definition

$$Q_1 \left(\underline{q}_R^3(q_S) \right) = \frac{P(m_1 | B, E_3)}{P(m_1 | A, E_3)}.$$

Using the fact that $\frac{\partial Q_1(q_R)}{\partial q_R} > 0, \forall q_R$, it follows that there is some $\varepsilon^{**} \in (0, \varepsilon^*)$ s.t.

$$\begin{aligned} Q_1 \left(\underline{q}_R^3(q_S) - \varepsilon^{**} \right) &= \frac{P(m_3 | B, E_4(t_2^4(\varepsilon^{**})))}{P(m_3 | A, E_4(t_2^4(\varepsilon^{**})))}, \\ Q_1 \left(\underline{q}_R^3(q_S) - \varepsilon \right) &> \frac{P(m_3 | B, E_4(t_2^4(\varepsilon^{**})))}{P(m_3 | A, E_4(t_2^4(\varepsilon^{**})))}, \forall \varepsilon \in (0, \varepsilon^{**}). \end{aligned}$$

It follows that for any $\varepsilon \in (0, \varepsilon^{**})$

$$Q_1 \left(\underline{q}_R^3(q_S) - \varepsilon \right) > \frac{P(m_1 | B, E_4(t_2^4(\varepsilon^{**})))}{P(m_1 | A, E_4(t_2^4(\varepsilon^{**})))} > \frac{P(m_1 | B, E_4(t_2^4(\varepsilon)))}{P(m_1 | A, E_4(t_2^4(\varepsilon)))}.$$

Furthermore, recall that it is trivially true that for any $\varepsilon \in (0, \varepsilon^{**})$

$$Q_2(\bar{q}_R^3(q_S) - \varepsilon) < Q_2(\bar{q}_R^3(q_S)) \leq \frac{P(m_2|B, E_3)}{P(m_2|A, E_3)} \leq \frac{P(m_3|B, E_4(t_2^4(\varepsilon)))}{P(m_3|A, E_4(t_2^4(\varepsilon)))}.$$

It follows that if and only if (49) holds, there exists a threshold $\underline{q}_R^4(q_S)$ satisfying $\underline{q}_R^4(q_S) < \bar{q}_R^3(q_S)$ s.t. there exists a monotone 4-partitions equilibrium if $q_R \in [\underline{q}_R^4(q_S), \bar{q}_R^3(q_S)]$ and there exists no monotone 4-partitions equilibrium if $q_R < \underline{q}_R^4(q_S)$. ■

References

- [1] Alesina, A. and Cukierman, A., 1990, The Politics of Ambiguity, *The Quarterly Journal of Economics*, 105(4)
- [2] Aragonès, E. and Neeman, Z., 2000, Strategic Ambiguity in Electoral Competition, *Journal of Theoretical Politics*, 12(2)
- [3] Azrieli, Y. and Teper, R., 2011, Uncertainty aversion and equilibrium existence in games with incomplete information, *Games and Economic Behavior*, 73(2)
- [4] Bade, S., 2010, Ambiguous Act Equilibria, Working Paper, mimeo
- [5] Blume, A. and Board, O., 2012, Language Barriers, *Econometrica* (forthcoming)
- [6] Blume, A. and Board, O., 2010, Intentional Vagueness, mimeo
- [7] Blume, A. and Board, O. and Kawamura, K., 2007, Noisy Talk, *Theoretical Economics*, 2(4)
- [8] Bose, S. and Renou, L., 2011, Mechanism Design and Ambiguous Communication Devices, mimeo
- [9] Callander, S. and Wilson, C.H., 2008, Context-dependent voting and political ambiguity, *Journal of Public Economics* 92(3)
- [10] Crawford V. and Sobel, J., 1982, Strategic Information Transmission, *Econometrica*, 50(6)
- [11] Di Tillio, A., Kos, N. and Messner, M., 2011, The Design of Ambiguous mechanisms, mimeo
- [12] Gilboa, I., 1987, Expected utility with purely subjective non-additive probabilities, *Journal of Mathematical Economics*, 16(1)

- [13] Gilboa, I. and Schmeidler, D., 1989, Maxmin expected utility with a non-unique prior, *Journal of Mathematical Economics*, 18(2)
- [14] Hanany, E., & Klibanoff, P., 2007, Updating preferences with multiple priors, *Theoretical Economics*, 2(3)
- [15] Hanany, E., & Klibanoff, P., 2009, Updating ambiguity averse preferences, *The BE Journal of Theoretical Economics*, 9(1)
- [16] Hayashi, F., 2010, 2010, Proof of 7.2.14 on p. 466, Online Addendum
- [17] Hayashi, F., 2000, *Econometrics*, Princeton University Press
- [18] Klibanoff, P., Marinacci, M. and Mukerji, S., 2005, A smooth model of decision making under ambiguity , *Econometrica*, 73(6)
- [19] Riedel, F. and Sass, L., 2011, The strategic use of Ambiguity, mimeo
- [20] Siniscalchi, M., 2011, Dynamic choice under ambiguity, *Theoretical Economics* 6(3).
- [21] Tomz, M. and Van Houweling, R. P., 2009, The Electoral Implications of Candidate Ambiguity, *American Political Science Review*, 103(1)
- [22] Wijsman, R. A., 1985, A Useful Inequality on Ratios of Integrals, With Application to Maximum Likelihood Estimation, *Journal of the American Statistical Association*, 80(390)