

Billand, Pascal; Bravard, Christophe; Kamphorst, Jurjen; Sarangi, Sudipta

**Working Paper**

## Confirming Information Flows in Networks

Tinbergen Institute Discussion Paper, No. 12-019/1

**Provided in Cooperation with:**

Tinbergen Institute, Amsterdam and Rotterdam

*Suggested Citation:* Billand, Pascal; Bravard, Christophe; Kamphorst, Jurjen; Sarangi, Sudipta (2012) : Confirming Information Flows in Networks, Tinbergen Institute Discussion Paper, No. 12-019/1, Tinbergen Institute, Amsterdam and Rotterdam, <https://nbn-resolving.de/urn:nbn:nl:ui:15-1765/31779>

This Version is available at:

<https://hdl.handle.net/10419/87439>

**Standard-Nutzungsbedingungen:**

Die Dokumente auf EconStor dürfen zu eigenen wissenschaftlichen Zwecken und zum Privatgebrauch gespeichert und kopiert werden.

Sie dürfen die Dokumente nicht für öffentliche oder kommerzielle Zwecke vervielfältigen, öffentlich ausstellen, öffentlich zugänglich machen, vertreiben oder anderweitig nutzen.

Sofern die Verfasser die Dokumente unter Open-Content-Lizenzen (insbesondere CC-Lizenzen) zur Verfügung gestellt haben sollten, gelten abweichend von diesen Nutzungsbedingungen die in der dort genannten Lizenz gewährten Nutzungsrechte.

**Terms of use:**

*Documents in EconStor may be saved and copied for your personal and scholarly purposes.*

*You are not to copy documents for public or commercial purposes, to exhibit the documents publicly, to make them publicly available on the internet, or to distribute or otherwise use the documents in public.*

*If the documents have been made available under an Open Content Licence (especially Creative Commons Licences), you may exercise further usage rights as specified in the indicated licence.*

TI 2012-019/1

Tinbergen Institute Discussion Paper



# Confirming Information Flows in Networks

*Pascal Billand*<sup>1</sup>

*Christophe Bravard*<sup>1</sup>

*Jurjen Kamphorst*<sup>2</sup>

*Sudipta Sarangi*<sup>3</sup>

<sup>1</sup> *Université de Lyon, Université Jean Monnet, Saint-Étienne, CNRS, GATE;*

<sup>2</sup> *Erasmus School of Economics, Erasmus University Rotterdam, and Tinbergen Institute;*

<sup>3</sup> *DIW Berlin, Louisiana State University.*

Tinbergen Institute is the graduate school and research institute in economics of Erasmus University Rotterdam, the University of Amsterdam and VU University Amsterdam.

More TI discussion papers can be downloaded at <http://www.tinbergen.nl>

Tinbergen Institute has two locations:

Tinbergen Institute Amsterdam  
Gustav Mahlerplein 117  
1082 MS Amsterdam  
The Netherlands  
Tel.: +31(0)20 525 1600

Tinbergen Institute Rotterdam  
Burg. Oudlaan 50  
3062 PA Rotterdam  
The Netherlands  
Tel.: +31(0)10 408 8900  
Fax: +31(0)10 408 9031

Duisenberg school of finance is a collaboration of the Dutch financial sector and universities, with the ambition to support innovative research and offer top quality academic education in core areas of finance.

DSF research papers can be downloaded at: <http://www.dsf.nl/>

Duisenberg school of finance  
Gustav Mahlerplein 117  
1082 MS Amsterdam  
The Netherlands  
Tel.: +31(0)20 525 8579

# Confirming Information Flows in Networks\*

Pascal Billand, Christophe Bravard<sup>†</sup>, Jurjen Kamphorst<sup>‡</sup>, Sudipta Sarangi<sup>§</sup>

February 29, 2012

## Abstract

Social networks, be it on the internet or in real life, facilitate information flows. We model this by giving agents incentives to link with others and receive information through those links. In many networks agents will value confirmation of the information they receive from others. Our paper analyzes the impact such a need for confirmation has on the social networks which are formed. We first study the existence of Nash equilibria and then characterize the set of strict Nash networks. Next, we characterize the set of strictly efficient networks and discuss the relationship between strictly efficient networks and strict Nash networks.

*JEL Classification: C72, D85.*

*Key Words: connections model, confirmation, two-way flow models.*

## 1 Introduction

Social networks are purveyors of information where members of networks use their direct and indirect connections to gather information from others. A very substantial literature

---

\*We thank Matt Jackson and Herve Moulin for useful suggestions. We also thank seminar participants at Indiana University, Rice, Vanderbilt, SING 2011 and PET 2011 meetings for helpful comments.

<sup>†</sup>Université de Lyon, Lyon, F-69003, France ; Université Jean Monnet, Saint-Etienne, F-42000, France; CNRS, GATE Lyon St Etienne, Saint-Etienne, F-42000, France. email: pascal.billand@univ-st-etienne.fr, christophe.bravard@univ-st-etienne.fr.

<sup>‡</sup>Erasmus School of Economics and Tinbergen Institute. email: kamphorst@ese.eur.nl.

<sup>§</sup>DIW Berlin and Department of Economics, Louisiana State University, Baton Rouge, LA 70803, USA. email: sarangi@lsu.edu.

covers different aspects of this topic with one of the classics being Granovetter [8] who studies transmission of information about job opportunities. Learning from one’s neighbors is studied by Bala and Goyal [1] while Goyal and Galeotti [6] examine how information (modeled as a public good) is gathered in the network. In situations where the information acquired through the network is used in making decisions, the reliability of this information matters, creating a need for the confirmation of information. The focus of our paper is precisely on this issue - how does the need to confirm information affect network formation? This need already echoed in the *Book of Deuteronomy* which states that “On the testimony of two or three witnesses a man [who has done an evil deed] shall be put to death, but no one shall be put to death on the testimony of only one witness” (17:6). Such confirmation is a key part of our judicial system where it is often necessary to have multiple witnesses who can corroborate a piece of evidence.<sup>1</sup> While confirming information is important in legal circles, researchers also have a need for confirming information. When writing a survey paper, one often reads the original source as well as other interpretations of the same work in order to write a better scholarly piece. While attending a conference we often talk to different researchers about the same paper to enhance our understanding of it. One can also find other examples. For the sake of credibility journalists typically attempt to confirm information in several different ways. Government agencies also usually need to confirm information prior to acting on it.<sup>2</sup>

In this paper we model the desire for confirmation by allowing for the possibility of both *unconfirmed* and *confirmed* information. Agents in the model form a network to acquire information by creating links with each other. Our objective is to identify stable networks using the concepts of (strict) Nash network and (strict) bilateral rational network when agents make decisions based on the benefits and costs of links. We establish when such equilibrium networks exist and how they differ from efficient networks, *i.e.*, networks that maximize aggregate payoffs.

Formally, we consider a setting where each agent, modeled as a node in the network, is a

---

<sup>1</sup>There is a large body of work in law and psychology that examines the accuracy of witness testimony and suggests that it depends on a number of factors like memory, age as well as the process of obtaining the testimony. For an early perspective on this see Morgan [17] and for more recent work see Wells and Olson [19].

<sup>2</sup>All these cases require corroboration of information, that is using additional information to validate already obtained information. In other words, agents look for other information to support and reconconfirm (or to challenge or rebut) information they have found. There is an extensive literature on this subject (see for instance Miranda, Vercellesi and Bruno [16], and Jick [13]).

source of benefits that others can tap via the formation of costly links. We assume that a link with another agent allows access to the benefits available to the latter through her own (direct and indirect) links. In the model the costs of link formation are incurred only by the agent who sponsors the link and the links formed by the agents define a social network. Information that is obtained through one path, or sequence of links is said to be unconfirmed, while information that is obtained through at least one other distinct path in the network is said to be confirmed. In our setting information obtained through two distinct paths (or confirmed information) is worth more to an agent than that obtained through a direct or a single set of links (unconfirmed information).<sup>3</sup> Consequently, the payoff obtained by each agent in a social network depends on (i) the number of confirmed resources she obtains from other agents, (ii) the number of unconfirmed resources she obtains from other agents, and (iii) the number of links she sponsors and so the costs she incurs. It is worth noting that our formulation introduces heterogeneity endogenously in the model by allowing for the value of information to depend on the network structure.<sup>4</sup>

Our analysis of network formation in this model provides a number of interesting insights. First, we show that Nash networks in pure strategies may not exist under a general payoff function that incorporates the three elements mentioned above. However, we find that a Nash network always exists if the function which captures the costs of sponsoring links is convex. Second, we characterize strict Nash networks. We show that connected<sup>5</sup> strict Nash networks have simple architectures: they are minimally confirmed networks or center sponsored stars.<sup>6</sup> Then, we show that non-connected strict Nash networks contain wheels<sup>7</sup> and at most one subnetwork which is either empty, or connected. Third, we examine situations where

---

<sup>3</sup>In computer science there is also a body of literature that considers distinct paths in routing applications (see for instance Lee and Gerla [15] and Tsirigos and Haas [18]). Although this phenomenon called multipath routing is not used to confirm information it increases the payoffs of players at higher costs by lowering delay, providing better security or improving fault tolerance. Thus our formal model can also be used to study situations where there is an explicit need for redundancy or alternate paths.

<sup>4</sup>The typical approach for introducing heterogeneity in the standard model has been through different exogenously given values and costs of links. See for instance Galeotti, Goyal and Kamphorst [7], and Billand, Bravard and Sarangi [5].

<sup>5</sup>A network is connected if there is a path between every pair of agents.

<sup>6</sup>A minimally confirmed network is a network where each player obtains confirmed resources from every other player and if a link is removed from this network, then at least one player loses some confirmed resources. A center sponsored star is a network where a player  $i$  sponsors a link with each other player while other players do not sponsor any links.

<sup>7</sup>In a wheel each player forms and receives one link.

pair of players make bilateral deviations in order to make a Pareto improvement in their payoffs. We show that these bilateral deviations allow to obtain connected networks as non-empty equilibrium networks. Fourth, we study strict efficient networks. Since it is difficult to characterize strict efficient networks with a general payoff function we restrict our attention to the cases where the payoff function is linear. We show that a strict efficient network is either a minimal unconfirmed network, or a minimal network that is cyclic. Finally, we discuss the implications of a decay assumption in our framework.

Our paper is inspired by the Nash networks model of Bala and Goyal [2] and here we focus on the two-way flow version of their connections model (in the following we refer to this model as the standard model). In Bala and Goyal’s model a set of agents simultaneously decide who they wish to link with which in turn determines the network structure.<sup>8</sup> As in our model links are established as long as the agent initiating the link pays for it. Moreover, each agent obtains the information of agents she is directly or indirectly connected to. The difference between our paper and the work of Bala and Goyal lies in the fact that players do not obtain additional payoff from the confirmation of resources in the standard model. Thus, our paper can also be viewed as an extension of the standard model of Bala and Goyal [2]. When confirming information is prohibitively expensive, then we will obtain unconfirmed equilibrium networks which will correspond with the results of Bala and Goyal. But we also find that the introduction of the confirmation assumption creates other interesting possibilities – we find strict Nash networks which are neither empty, nor connected. Moreover, we show that the confirmation assumption may lead to equilibrium networks where players are asymmetric with regard to the resources they obtain, a kind of asymmetry that never arises in the standard model.

A number of variations of the standard model have also been developed in which there are some benefits from having different paths. However, all of these rely on link imperfections of some type or the other. One of these considers the possibility that links can fail with an exogenously given probability. See for instance Bala and Goyal [3] who introduce the basic model and Haller and Sarangi [9] who allow for exogenously given heterogeneity in this model. Since links can fail, the incentive for alternate paths in this model is a type of insurance against link failure that provides an access to the same information. In another

---

<sup>8</sup>Unlike the model of Jackson and Wolinsky [11], there are no consent issues here.

class of models introduced by Bala and Goyal [2] and generalized by Hojman and Szeidl [10] the value of information acquired from agents that are farther away in the network decreases in value.<sup>9</sup> Under certain situations this creates an incentive to establish an alternative path to an agent with whom a player is already linked. Note that in decay models the loss of information through the network is “continuous” with distance, while in our model the loss of information may be considered “discontinuous”. The major difference between our model and decay models is that in these models the shortest path acts as the purveyor of information, while in our model distinct paths are crucial. This has consequences for the set of strict Nash networks: decay models have core-periphery or star type architectures, while the confirmation requirement allows for a much bigger set of architectures to be strict Nash.

The paper is organized as follows. In section 2 we present the model setup. In section 3 we characterize strict Nash networks and we provide a condition which ensures the existence of Nash networks in pure strategies. In section 4 we discuss the role played by decay in a model with a confirmation assumption.

## 2 Model setup

This model is based on the two-way flow connection model initiated by Bala and Goyal [2].

**Networks definitions.** We begin by giving the formal definition of a directed network. A network  $\mathbf{g}$  is an ordered pair of disjoint sets  $(N, A)$  such that  $A$  is a subset of the set  $N \times N$  of ordered pairs of  $N$ . The set  $N$ , with  $|N| \geq 3$ , is the set of vertices which will be identified with the players and  $A = A(\mathbf{g})$  is the set of arcs which will be identified with the relations or links between the players. We assume that there is no arc from a player  $i$  to herself. An ordered pair  $(i, j) \in A(\mathbf{g})$  is said to be an arc directed from  $i$  to  $j$  and is denoted  $ij$ . In such a case  $i$  is said to be the sponsor of  $ij$  and  $j$  the recipient of  $ij$ . Let  $A_i(\mathbf{g}) = \{kj \in A(\mathbf{g}) : k = i\}$  be the set of arcs sponsored by player  $i$  in  $\mathbf{g}$  and let  $A_{-i}(\mathbf{g}) = A(\mathbf{g}) \setminus A_i(\mathbf{g})$  be the set of arcs sponsored by players  $j \neq i$  in  $\mathbf{g}$ . The set of arcs of  $\mathbf{g}$  can be written as  $A(\mathbf{g}) = A_i(\mathbf{g}) \cup A_{-i}(\mathbf{g})$ .

---

<sup>9</sup>Bala and Goyal [2] give a characterization of the equilibrium networks of diameters 2 and 3. This characterization is extended to equilibrium networks of all diameters by De Jaegher and Kamphorst [12]. Billand, Bravard and Sarangi [4] deal with the implications of exogenous heterogeneity in the presence of decay. Note that in models that allow for link imperfections and exogenously given heterogeneity, in equilibrium the set of Nash networks is quite large. This is not the case when heterogeneity occurs endogeneously as in our case.



To simplify the notation, we write  $A_i(\mathbf{g}) \cup \{i j\} = A_i(\mathbf{g}) + i j$  and  $A_i(\mathbf{g}) \setminus \{i j\} = A_i(\mathbf{g}) - i j$ . For consistency, we write  $A(\mathbf{g}) \cup \{i j\} = A(\mathbf{g}) + i j$  and  $A(\mathbf{g}) \setminus \{i j\} = A(\mathbf{g}) - i j$ . We denote by  $\mathbf{g}^{ij}$  the network  $(N, A(\mathbf{g}) + i j)$ , and  $\mathbf{g}^{-ij}$  the network  $(N, A(\mathbf{g}) - i j)$ . We say that  $\overline{ij} \in A(\mathbf{g})$  if and only if  $ij \in A(\mathbf{g})$ , or  $ji \in A(\mathbf{g})$ . Let  $\mathcal{G}$  be the set of directed networks with  $N$  as the set of vertices.

Let  $V_i(A(\mathbf{g})) = \{j \in N \setminus \{i\} : ij \in A_i(\mathbf{g}) \text{ or } ji \in A_j(\mathbf{g})\}$  be the set of players with whom  $i$  is directly linked in  $\mathbf{g}$ . If  $|V_i(A(\mathbf{g}))| \geq 3$ , then player  $i$  is called a *key player* in  $\mathbf{g}$ .

For a directed network,  $\mathbf{g}$ , a *chain*  $C_{i_0, i_\ell}(\mathbf{g})$  in  $\mathbf{g}$  between player  $i_0$  and player  $i_\ell$  is an alternating sequence of players and arcs:  $i_0, x_1, i_1, x_2, \dots, x_\ell, i_\ell$  in which all players are distinct and each arc  $x_m$  is either  $i_{m-1}i_m$  or  $i_m i_{m-1}$ .<sup>10</sup> We denote by  $N(C_{i_0, i_\ell}(\mathbf{g}))$  the set of players contained in the chain  $C_{i_0, i_\ell}(\mathbf{g})$ . Let  $C_{i_0, i_\ell}(\mathbf{g})$  and  $C'_{i_0, i_\ell}(\mathbf{g})$  be two different chains between  $i_0$  and  $i_\ell$  in  $\mathbf{g}$ . These chains are independent if  $N(C_{i_0, i_\ell}(\mathbf{g})) \cap N(C'_{i_0, i_\ell}(\mathbf{g})) = \{i_0, i_\ell\}$ . Let  $X_{i_0, i_\ell}(\mathbf{g}) = \{C_{i_0, i_\ell}^1(\mathbf{g}), \dots, C_{i_0, i_\ell}^m(\mathbf{g})\}$  be a set of independent chains between  $i_0$  and  $i_\ell$  in  $\mathbf{g}$ . The set of sets of independent chains between  $i_0$  and  $i_\ell$  in  $\mathbf{g}$  is denoted by  $\mathcal{X}_{i_0, i_\ell}(\mathbf{g})$ . Let  $\mathcal{C}_{i_0, i_\ell}^I(\mathbf{g}) \in \mathcal{X}_{i_0, i_\ell}(\mathbf{g})$  be a set of independent chains between  $i_0$  and  $i_\ell$  in  $\mathbf{g}$  such that  $|\mathcal{C}_{i_0, i_\ell}^I(\mathbf{g})| \geq |X_{i_0, i_\ell}(\mathbf{g})|$  for all  $X_{i_0, i_\ell} \in \mathcal{X}_{i_0, i_\ell}$ . Let  $N_i(A(\mathbf{g}))$  be the set of players  $j \in N \setminus \{i\}$  such that there is a chain between  $i$  and  $j$  in  $\mathbf{g}$ . If there exists a chain between  $i$  and  $j$  in  $\mathbf{g}$ , then  $i$  and  $j$  are said to be connected in  $\mathbf{g}$ . A *cycle* consists of a chain together with an arc between the terminal player and the initial one of the chain. A *wheel* is a cycle where each player sponsors one arc and receives one arc.

A network  $\mathbf{g}$  is *connected* if each player  $i \in N$  is connected with each other player  $j \in N \setminus \{i\}$ . A network  $\mathbf{g}$  is *minimally unconfirmed* if for any arc  $ij \in A(\mathbf{g})$  there exists a pair of players  $k, \ell$  who are connected in  $\mathbf{g}$ , while they are not connected in  $\mathbf{g}^{-ij}$ . In other words, players  $k$  and  $\ell$  are connected in  $\mathbf{g}$  with the arc  $ij$ , while they are not connected without this arc. A network  $\mathbf{g}$  is *confirmed*, if for all players  $i \in N$  and  $j \in N \setminus \{i\}$ , we have  $|\mathcal{C}_{i, j}^I(\mathbf{g})| \geq 2$ . A network  $\mathbf{g}$  is *minimally confirmed*, if for any arc  $ij \in A(\mathbf{g})$  there exists a pair of players  $k, \ell$  such that  $|\mathcal{C}_{k, \ell}^I(\mathbf{g})| = 2$  while  $|\mathcal{C}_{k, \ell}^I(\mathbf{g}^{-ij})| = 1$ . In other words, players  $k$  and  $\ell$  obtains resources from each other from two independent chains in  $\mathbf{g}$  while they obtain resources from each other from one chain when the arc  $ij$  is removed. A *sub-network* of  $\mathbf{g} = (N, A)$ , say  $\mathbf{g}_{|X}$ , is a network where the set of vertices,  $X$ , is a subset of  $N$  and an arc  $ij$  belongs to  $A(\mathbf{g}_{|X})$  if and only if  $ij$

---

<sup>10</sup>Chain is called path in some papers.

belongs to  $A(\mathbf{g})$ . A maximal connected sub-network of  $\mathbf{g}$  is a *component*. Let  $\mathcal{W}(\mathbf{g})$  be the set of players who belong to components which are wheels in  $\mathbf{g}$  and let  $\mathbf{g}_{|_{N \setminus \mathcal{W}}}$  be the sub-network induced by the players in  $N \setminus \mathcal{W}(\mathbf{g})$  in  $\mathbf{g}$ . It is obvious that if  $\mathbf{g}_{|_W}$  is a wheel of  $\mathbf{g}$ , then we have  $W(\mathbf{g}) \subset \mathcal{W}(\mathbf{g})$ . A *star* is a network where a player, say  $i$ , is involved in an arc with all other players while other players are involved only in the arc with  $i$ . A *center sponsored star* is a network where there is a player who sponsors an arc with all other players while other players do not form any arc. A *periphery sponsored star* is a network where a player receives an arc from each other player and where there are no other arcs. A network  $\mathbf{g}$  is a *minimal cycle network* if it is minimally confirmed and contains  $n$  arcs. A network  $\mathbf{g}$  is a *base network* if there does not exist a network  $\mathbf{g}'$  such that

1.  $N_i^C(\mathbf{g}') = N_i^C(\mathbf{g})$ ,  $N_i^U(\mathbf{g}') = N_i^U(\mathbf{g})$ , for all players  $i \in N$ ;
2. There exists a player  $i$  such that  $|A_i(\mathbf{g}')| < |A_i(\mathbf{g})|$  and for all players  $j \in N \setminus \{i\}$ ,  $A_j(\mathbf{g}') = A_j(\mathbf{g})$ .

It is clear that a base network is minimally connected.

A network  $\mathbf{g}$  is a *minimal base network* if there does not exist any base network  $\mathbf{g}'$  such that

1.  $N_i^C(\mathbf{g}') = N_i^C(\mathbf{g})$ ,  $N_i^U(\mathbf{g}') = N_i^U(\mathbf{g})$ , for all players  $i \in N$ ;
2.  $|A(\mathbf{g}')| < |A(\mathbf{g})|$ .

A bipartite network is a network whose vertices can be divided into two disjoint sets  $X_1$  and  $X_2$  such that every arc connects a vertex in  $X_1$  to one in  $X_2$ . Finally, a player who sponsors and receives no arcs is called an isolated player.

We now illustrate some network architectures.

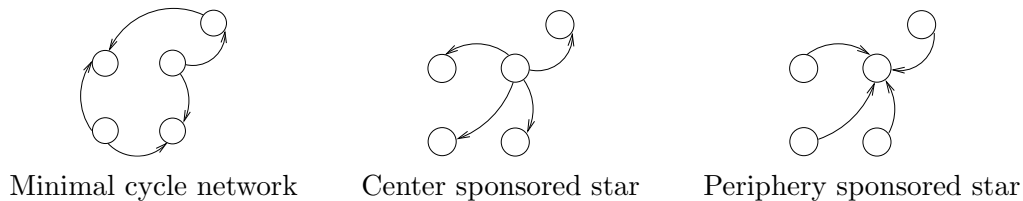

Figure 1: Networks architectures

In Figure 2, network  $\mathbf{g}^1$  is not a base network since the arc 5 4 is not needed. Network  $\mathbf{g}^2$  is a base network and  $\mathbf{g}^3$  is a minimal base network.

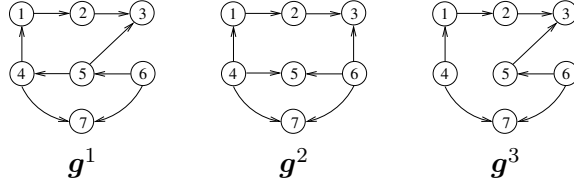

Figure 2: Base and minimal base networks

**Strategies of players.** Let  $G_i = \{ij : j \in N \setminus \{i\}\}$  be the set of arcs that player  $i$  can form with other players. In our context, each player  $i \in N$  chooses a strategy which consists in forming arcs:  $A_i(\mathbf{g}) \in 2^{G_i}$ . In this paper, we only use pure strategies. It is worth noting that the set of arcs between distinct players of network  $\mathbf{g}$  is  $A(\mathbf{g}) = \bigcup_{i \in N} A_i(\mathbf{g})$ . Given a network  $\mathbf{g} \in \mathcal{G}$ ,  $A_{-i}(\mathbf{g}) = \bigcup_{j \in N \setminus \{i\}} A_j(\mathbf{g})$  denotes the strategies profile played by all players except  $i$ .

**Payoffs.** To complete the definition of the normal-form game of network formation, we specify the payoffs. When two players are connected, they gain access to each other's information. More precisely, if two players are connected via several independent chains, they access each other's information and they can be certain that the information is correct. This is called *confirmed access* or *confirmed connection*. However, if they are not connected via several independent chains, they cannot be certain of the information received. This reduces the value of the information. We call this *unconfirmed access* or *unconfirmed connection*. We assume that each player  $i$  prefers to obtain confirmed information instead of unconfirmed information. We define the confirmed players set as

$$N_i^C(A(\mathbf{g})) = \{j \in N \setminus \{i\} : |C_{i,j}^I(\mathbf{g})| \geq 2\},^{11}$$

and the unconfirmed players set as

$$N_i^U(A(\mathbf{g})) = \{j \in N \setminus \{i\} : |C_{i,j}^I(\mathbf{g})| = 1\}.$$

Obviously, we have  $j \in N_i^C(A(\mathbf{g}))$  implies  $i \in N_j^C(A(\mathbf{g}))$  and  $j \in N_i^U(A(\mathbf{g}))$  implies  $i \in N_j^U(A(\mathbf{g}))$ . An equivalent confirmation set (ECS) is a set of players where each player of this

<sup>11</sup>It is worth noting that in a component which contains only two players, say  $i$  and  $j$ , these players cannot receive confirmed resources from each other since there is only one chain between them.

set obtains confirmed information from each other player of this set. A maximal equivalent confirmation set (MECS) is a ECS which is not a subset of another ECS. Formally, we define the set of equivalent confirmation sets as follows:  $E(\mathbf{g}) = \{X \subset N : i \in X, j \in X \Rightarrow j \in N_i^C(\mathbf{g})\}$ . Likewise, the set of maximal equivalent confirmation sets is:  $E^M(\mathbf{g}) = \{X \in E(\mathbf{g}) : \text{there is no } X' \in E(\mathbf{g}), X \subset X'\}$ . Let  $M(\mathbf{g}) = \{j \in N : j \in X \cap X' \text{ with } X, X' \in E^M(\mathbf{g})\}$  be the set of players who belong simultaneously to several MECS. We illustrate the construction of these sets through the following example.

**Example 1** In network  $\mathbf{g}$  drawn in Figure 1, we have  $E^M(\mathbf{g}) = \{A, B, C, D, E\}$ ,  $M(\mathbf{g}) = \{1, 3, 5, 6\}$ .

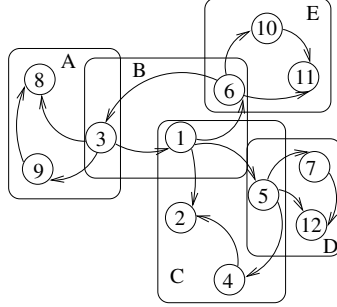

Now we come to the (dis)incentives for players to sponsor arcs: each arc is costly to form for its initiator.

We now formally define the payoff function of each player  $i$ . Let  $f_1, f_2, f_3$  be increasing functions. We assume that for all  $x, x' > 0$  and  $y \leq x'$ ,  $f_1(x + y) + f_2(x' - y) > f_1(x) + f_2(x')$ . The payoff function of each player  $i$ , given a network  $\mathbf{g}$ , is:

$$\pi_i(A(\mathbf{g})) = f_1(|N_i^C(A(\mathbf{g}))|) + f_2(|N_i^U(A(\mathbf{g}))|) - f_3(|A_i(\mathbf{g})|). \quad (1)$$

The assumption, called (A1) in the following, on  $f_1(x + y) + f_2(x' - y) > f_1(x) + f_2(x')$  implies that the payoff of agent  $i$  increases when simultaneously the number of confirmed resources obtained by  $i$  increases by  $y$ , and the number of unconfirmed resources obtained by  $i$  decreases by  $y$ . Moreover, since  $f_3$  is increasing, the payoff function of player  $i$  decreases with the number of arcs she forms, given  $|N_i^C(A(\mathbf{g}))|$  and  $|N_i^U(A(\mathbf{g}))|$ .

In the following, some results are established for the linear payoff function:

$$\pi_i^L(A(\mathbf{g})) = V^C |N_i^C(A(\mathbf{g}))| + V^U |N_i^U(A(\mathbf{g}))| - c|A_i(\mathbf{g})|, \quad (2)$$

with  $V^C > V^U > 0$ , and  $c > 0$ .

**Strict Nash networks, strict bilateral rational networks and efficient networks.**

The strategy  $A_i(\mathbf{g})$  is said to be a best response of player  $i$  against the strategy  $A_{-i}(\mathbf{g})$  if:

$$\pi_i(A_i(\mathbf{g}), A_{-i}(\mathbf{g})) \geq \pi_i(A', A_{-i}(\mathbf{g})), \text{ for all } A' \in 2^{G_i}. \quad (3)$$

The set of all of player  $i$ 's best responses to  $A_{-i}(\mathbf{g})$  is denoted by  $\mathcal{BR}_i(A_{-i}(\mathbf{g}))$ . A network  $\mathbf{g}$  is said to be a Nash network if  $A_i(\mathbf{g}) \in \mathcal{BR}_i(A_{-i}(\mathbf{g}))$  for each player  $i \in N$ . We define a strict best response and a strict Nash network by replacing ' $\geq$ ' by '>' and by setting  $A' \in 2^{G_i} \setminus \{A_i(\mathbf{g})\}$ .

To capture the possibility of strict bilateral deviation in our setting, we use *strict bilateral rational networks* which are a slight variation of stable equilibrium networks introduced by Kim and Wong [14]. A strict bilateral rational network is a strict Nash network where given all other players strategies, no pair of players can propose a joint change in their own strategies that strictly improves both players' payoff. This assumption is intuitively reasonable and can be regard as a minimal assumption that captures the cooperative or lobbying behavior of players. Moreover, each player should not have any incentive to modify unilaterally her strategy, that is each player plays a strict best response.

We now define this solution formally. Let  $A_{-ij}(\mathbf{g}) = \bigcup_{\ell \in N \setminus \{i,j\}} A_\ell(\mathbf{g})$  denotes the strategies profile played by all players except  $i$  and  $j$ . The pair of strategies  $A_{ij}(\mathbf{g}) = (A_i(\mathbf{g}), A_j(\mathbf{g}))$ <sup>12</sup> is said to be a strictly bilateral best response of players  $i$  and  $j$  against the strategy  $A_{-ij}(\mathbf{g})$  if there is no pair of strategies  $A'_{ij} \in 2^{G_i} \times 2^{G_j} \setminus A_{ij}(\mathbf{g})$ , such that

$$(\pi_i(A_{ij}(\mathbf{g}), A_{-ij}(\mathbf{g})), \pi_j(A_{ij}(\mathbf{g}), A_{-ij}(\mathbf{g}))) \leq (\pi_i(A'_{ij}, A_{-ij}(\mathbf{g})), \pi_j(A'_{ij}, A_{-ij}(\mathbf{g}))). \quad (4)$$

---

<sup>12</sup> $A_{ij}(\mathbf{g})$  can be interpreted as  $A_i(\mathbf{g}) \cup A_j(\mathbf{g})$ .

Equation 4 captures the idea that no pair of agents can make a joint deviation to make a weakly Pareto improvement for themselves. The set of all bilateral best responses of players  $i$  and  $j$  to  $A_{-i}(\mathbf{g})$  is denoted by  $\mathcal{BBR}_{ij}(A_{-ij})$ . A network  $\mathbf{g}$  is said to be a strict bilateral rational network if  $(A_i(\mathbf{g}), A_j(\mathbf{g})) \in \mathcal{BBR}_{ij}(A_{-ij})$  for each pair of players  $(i, j) \in N \times N$  and if  $A_i(\mathbf{g}) \in \mathcal{BR}_i(A_{-i}(\mathbf{g}))$ . Clearly, strict bilateral rational networks are a simple refinement concept for the strict Nash networks based on bilateral rationality.

We now define the total payoff function as  $W(\mathbf{g}) = \sum_{i \in N} \pi_i(A(\mathbf{g}))$ . An *efficient network*  $\mathbf{g}$  is a network such that  $W(\mathbf{g}) \geq W(\mathbf{g}')$ , for all  $\mathbf{g}' \in \mathcal{G}$ . We define a strict efficient network by replacing ' $\geq$ ' by '>', and ' $\mathcal{G}$ ' by ' $\mathcal{G} \setminus \{\mathbf{g}\}$ '.

## 3 Confirmation Model Analysis

### 3.1 Nash networks

We show that there does not always exist a Nash network in pure strategies. Then we provide a condition on the function which captures the role played by the cost of setting arcs in the payoff of the players. This condition ensures the existence of Nash networks in pure strategies. The function  $f_3$  is convex if  $f_3(x+1) - f_3(x) \geq f_3(x) - f_3(x-1)$ , for all  $x \in \{1, \dots, n-2\}$ .

**Proposition 1** *Suppose that payoff function is given by equation 1. Then, there does not always exist a Nash network. Suppose that payoff function is given by equation 1 and  $f_3$  is convex. Then a Nash network will always exist.*

**Proof** First, we show through an example that if the payoff function is given by equation 1, then there does not always exist a Nash network. Suppose  $N = \{1, 2, 3\}$  and  $f_1(0) = f_2(0) = f_3(0) = 0$ ,  $f_1(2) = 7$ ,  $f_2(1) = 5$ ,  $f_2(2) = 5.5$ ,  $f_3(1) = 4$  and  $f_3(2) = 5$ .<sup>13</sup> We show that no network can be Nash. Clearly a Nash network has at most 3 arcs. The empty network is not Nash since  $f_1(0) + f_2(2) - f_3(2) = 0.5 > 0 = f_1(0) + f_2(0) - f_3(0)$ . A network with one arc is not Nash since for the player who is not involved in the arc, we have:  $f_1(0) + f_2(2) - f_3(1) = 1.5 > 0 = f_1(0) + f_2(0) - f_3(0)$ , that is she has an incentive to

---

<sup>13</sup>It is worth noting that  $f_1(1)$  cannot appear in this model. Moreover,  $f_2(3)$  and  $f_3(3)$  cannot appear in our example.

form an arc with one of the players. No network with two arcs can be Nash. More precisely, in such a network either a player receives two arcs, or such a player does not exist. In the former case, we have:  $f_1(2) + f_2(0) - f_3(2) = 2 > 1.5 = f_1(0) + f_2(2) - f_3(1)$ , and each player who sponsors an arc has an incentive to add an arc. In the latter case, we have:  $f_1(0) + f_2(1) - f_3(0) = 5 > 1.5 = f_1(0) + f_2(2) - f_3(1)$ , and one of the players who has sponsored an arc has an incentive to remove it. No network with three arcs can be Nash. More precisely, in such a network there is at least one player who sponsors exactly one arc. This player is better off deleting this arc as  $f_1(2) + f_2(0) - f_3(1) = 7 - 4 = 3 < 5.5 = f_1(0) + f_2(2) - f_3(0)$ .

We now show that there always exists a Nash network when  $f_3$  is convex. We will show that if the empty network and the periphery sponsored stars are not Nash networks, then a wheel is a Nash network.

Let us begin with the empty network  $\mathbf{g}^e$ . In  $\mathbf{g}^e$  each player obtains a payoff equal to  $f_1(0) + f_2(0) - f_3(0)$ . There are two cases: either  $\mathbf{g}^e$  is Nash and the proof is complete, or it is not. In the latter case, players have an incentive to form arcs. It follows that there exists  $x$ ,  $1 \leq x \leq n - 1$ , such that  $f_1(0) + f_2(x) - f_3(x) > f_1(0) + f_2(0) - f_3(0)$ . Since  $f_2$  and  $f_3$  are strictly increasing, we have  $f_1(0) + f_2(n - 1) - f_3(1) > f_1(0) + f_2(x) - f_3(x)$  for some  $x$ ,  $1 \leq x \leq n - 1$ . In such a situation, players in a periphery sponsored star,  $\mathbf{g}^{ps}$ , have no incentive to remove arcs. There are two cases: either  $\mathbf{g}^{ps}$  is Nash and the proof is complete, or it is not. In the latter case, players have an incentive to form arcs in  $\mathbf{g}^{ps}$ . Consequently, we have:  $f_1(x + 1) + f_2(n - x - 2) - f_3(1 + x) > f_1(0) + f_2(n - 1) - f_3(1)$ , for some  $x$ ,  $1 \leq x \leq n - 2$ , that is  $f_1(x + 1) + f_2(n - x - 2) - (f_1(0) + f_2(n - 1)) > f_3(1 + x) - f_3(1)$ , for some  $x$ ,  $1 \leq x \leq n - 2$ . We show that if  $\mathbf{g}^e$  and  $\mathbf{g}^{ps}$  are not Nash networks, then a wheel is a Nash network. Indeed, we have  $f_1(n - 1) + f_2(0) - (f_1(0) + f_2(n - 1)) \geq f_1(x + 1) + f_2(n - x - 2) - (f_1(0) + f_2(n - 1)) > f_3(1 + x) - f_3(1) \geq f_3(1) - f_3(0)$ , for  $1 \leq x \leq n - 2$ . The first inequality comes from assumption A1, and the last inequality comes from the convexity of  $f_3$ . It follows that  $f_1(n - 1) + f_2(0) - f_3(1) > f_1(0) + f_2(n - 1) - f_3(0)$ , that is no player in a wheel has an incentive to remove her arc. It follows that a wheel is a Nash network.  $\square$

The intuition of the proof of the proposition is as follows. If the empty network is not Nash, then each player has an incentive to form at least one arc. There are two cases (a) If each player accept to maintain one arc when she obtains confirmed resources from all other

players, then the wheel is Nash. (b) If in the wheel players prefer to remove her link and obtain unconfirmed resources, then the periphery sponsored star is Nash.

Our second result highlights a general property of Nash networks: in equilibrium there do not exist superfluous arcs.

**Proposition 2** *Suppose that payoff function is given by equation 1 and  $\mathbf{g}$  is a Nash network. Then,  $\mathbf{g}$  is a base network.*

**Proof** Let  $\mathbf{g}$  be a Nash network. To introduce a contradiction, suppose  $\mathbf{g}$  is not a base network. Then, there is a costly arc, say  $ij$  which can be deleted by player  $i$  such that the resulting network allows player  $i$  to obtain the same total resources. This implies that player  $i$  has a strict incentive to remove the link  $ij$ . Consequently,  $\mathbf{g}$  is not a Nash network, a contradiction.  $\square$

The proof of the next proposition is given in the appendix.

**Proposition 3** *Suppose that payoff function is given by equation 1. Then, there exist  $f_1, f_2, f_3$  such that any minimally unconfirmed network is a Nash network.*

Proposition 3 illustrates that the set of Nash networks is very large.<sup>14</sup> However, a Nash network in which a player, say  $i$ , has multiple best responses is likely to be unstable since  $i$  may decide to switch to another payoff equivalent strategy. This motivates the examination of strict Nash networks. Consequently, we pursue the analysis by the characterization of strict Nash networks.

## 3.2 Strict Nash networks

First, we need to present five lemmas. The first one is a technical lemma. It shows that there is no player in a strict Nash network  $\mathbf{g}$  who belongs simultaneously to several MECS. To prove this lemma, we need to construct from  $\mathbf{g}$  a bipartite network called  $\mathbf{g}^M$ . The set of vertices of  $\mathbf{g}^M$  is  $M(\mathbf{g}) \cup E^M(\mathbf{g})$ . There is a link between  $i \in M(\mathbf{g})$  and  $X(\mathbf{g}) \in E^M(\mathbf{g})$  if  $i$  belongs to  $X(\mathbf{g})$  in  $\mathbf{g}^M$ .<sup>15</sup> In the next example, we illustrate the construction of the network  $\mathbf{g}^M$  from  $\mathbf{g}$ .

<sup>14</sup>Bala and Goyal [2] shows that the number of Nash networks increases rapidly with the number of players in the standard framework. In our framework, the number of Nash networks is larger than in the standard framework.

<sup>15</sup>In  $\mathbf{g}^M$  the direction of the links plays no role. Consequently, we use “link” instead of “arc” for network  $\mathbf{g}^M$ .



**Example 2** We construct from network  $\mathbf{g}$  in Figure 2.a, the network  $\mathbf{g}^M$  associated with  $\mathbf{g}$  in Figure 2.b.

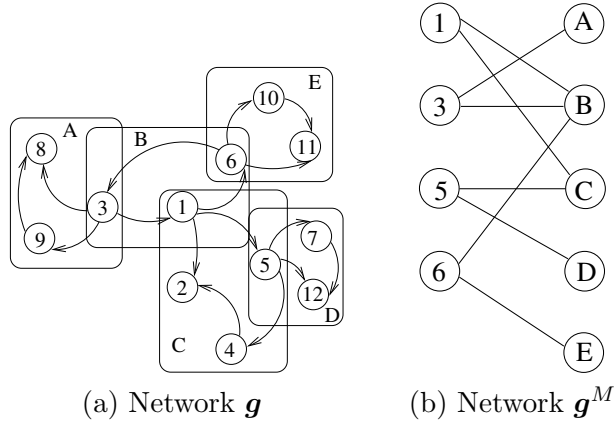

Figure 3: Construction of  $\mathbf{g}^M$

Notice that by construction the network  $\mathbf{g}^M$  contains no cycle, otherwise the set  $E^M(\mathbf{g})$  is not well defined.

**Lemma 1** Suppose that payoff function is given by equation 1 and  $\mathbf{g}$  is a strict Nash network. Then,  $M(\mathbf{g}) = \emptyset$ .

**Proof** We prove the lemma in two steps. First, we establish that each MECS has at most one link in  $\mathbf{g}^M$ . Second, we use this result to show that  $M(\mathbf{g}) = \emptyset$ .

1. We establish that each MECS has at most one link in  $\mathbf{g}^M$ . To introduce a contradiction suppose that there is a MECS, say  $X(\mathbf{g})$ , who has two links in  $\mathbf{g}^M$ . In the following, we focus on the component, say  $\mathcal{Z}(\mathbf{g})$ , which contains  $X(\mathbf{g})$  in  $\mathbf{g}^M$ . We know that  $\mathbf{g}^M$  is acyclic, so  $\mathcal{Z}(\mathbf{g})$  is acyclic. Consequently, there are two vertices in  $\mathcal{Z}(\mathbf{g})$  which have only one link. Moreover, by construction, each vertex in  $M(\mathbf{g})$  which belongs to  $\mathcal{Z}(\mathbf{g})$  has links with at least two vertices in  $\mathcal{Z}(\mathbf{g})$ . It follows that there are two vertices in  $E^M(\mathbf{g})$  which have only one link in  $\mathcal{Z}(\mathbf{g})$ . We conclude that there exist two MECS which belong to  $\mathcal{Z}(\mathbf{g})$ , say  $X_m(\mathbf{g}) \in E^M(\mathbf{g})$  and  $X'_m(\mathbf{g}) \in E^M(\mathbf{g})$ , which contains only one player who belongs to  $M(\mathbf{g})$ . We denote by  $i_m$  the unique player in  $M(\mathbf{g})$  who belongs to  $X_m(\mathbf{g})$  and by  $i'_m$  the unique player in  $M(\mathbf{g})$  who belongs to  $X'_m(\mathbf{g})$ . Since a MECS contains at

least 3 players,  $X_m(\mathbf{g})$  contains at least two players, say  $j \notin M(\mathbf{g})$  and  $k \notin M(\mathbf{g})$ , such that  $jk \in A(\mathbf{g})$ . By using the same arguments  $X'_m(\mathbf{g})$  contains two players  $j' \notin M(\mathbf{g})$  and  $k' \notin M(\mathbf{g})$  such that  $j'k' \in A(\mathbf{g})$ .

We now show that players  $j$  and  $j'$  cannot play simultaneously a strict best response in  $\mathbf{g}$ . We define  $\mathbf{g}'$  as the network such that  $A(\mathbf{g}') = A(\mathbf{g}) + jk' - jk$ . Likewise, we define  $\mathbf{g}''$  as the network such that  $A(\mathbf{g}'') = A(\mathbf{g}) + j'k - j'k'$ .

Let  $x < |X_m(\mathbf{g})| - 1$  be the number of confirmed resources that player  $j$  obtains when she removes her arc with player  $k$  in  $\mathbf{g}$  and let  $x' < |X'_m(\mathbf{g})| - 1$  be the number of confirmed resources that player  $j'$  obtains when she removes her arc with player  $k'$  in  $\mathbf{g}$ . Likewise, let  $y$  be the number of confirmed resources that player  $j$  obtains in  $\mathbf{g}'$  from players who belong neither to  $X_m(\mathbf{g})$ , nor to  $X'_m(\mathbf{g})$  (it is also the number of confirmed resources that player  $j'$  obtains in  $\mathbf{g}''$  from players who belong neither to  $X_m(\mathbf{g})$ , nor to  $X'_m(\mathbf{g})$ ).

Let  $K$  be the number of players from whom player  $j$  obtains unconfirmed resources and who do not belong to  $X'_m(\mathbf{g})$  (it is also the number of players from whom player  $j'$  obtains unconfirmed resources and who do not belong to  $X_m(\mathbf{g})$ ).

Suppose that player  $j$  replaces the arc  $jk$  by the arc  $jk'$ . We have:

$$\begin{aligned} \Delta_j &= \pi_j(A(\mathbf{g}')) - \pi_j(A(\mathbf{g})) = f_1(x + y + |X'_m|) + f_2(K + (|X_m| - 1 - x - y)) \\ &\quad - f_1(|X_m| - 1) - f_2(K + |X'_m|). \end{aligned}$$

We obtain:

$$0 > \Delta_j \geq f_1(|X'_m|) + f_2(K + |X_m| - 1) - f_1(|X_m| - 1) - f_2(K + |X'_m|). \quad (5)$$

The first inequality comes from the strict Nash property of  $\mathbf{g}$  and the second inequality comes from the assumption (A1) made on the payoff function.

Suppose that player  $j'$  replaces the arc  $j'k'$  by the arc  $j'k$ . We have:

$$\begin{aligned}
\Delta_{j'} &= \pi_{j'}(A(\mathbf{g}')) - \pi_{j'}(A(\mathbf{g})) = f_2(K + (|X'_m(\mathbf{g})| - 1 - x' - y)) \\
&\quad + f_1(x' + y + |X_m(\mathbf{g})|) \\
&\quad - f_1(|X'_m(\mathbf{g})| - 1) - f_2(K + |X_m(\mathbf{g})|).
\end{aligned}$$

We obtain:

$$0 > \Delta_{j'} \geq f_1(|X_m(\mathbf{g})|) + f_2(K + |X'_m(\mathbf{g})| - 1) - f_1(|X'_m(\mathbf{g})| - 1) - f_2(K + |X_m(\mathbf{g})|). \quad (6)$$

The first inequality comes from the strict Nash property of  $\mathbf{g}$  and the second inequality comes from the assumption (A1) made on the payoff function. By Assumption (A1), we have  $f_1(|X'_m(\mathbf{g})|) + f_2(K + (|X_m(\mathbf{g})| - 1)) > f_1(|X'_m(\mathbf{g})| - 1) + f_2(K + (|X_m(\mathbf{g})|))$  and  $f_1(|X_m(\mathbf{g})|) + f_2(K + (|X'_m(\mathbf{g})| - 1)) > f_1(|X_m(\mathbf{g})| - 1) + f_2(K + (|X'_m(\mathbf{g})|))$ . It follows that equations 5 and 6 are not compatible. A contradiction.

2. We show that  $M(\mathbf{g}) = \emptyset$ . Suppose  $\mathbf{g}$  is a strict Nash network and  $i \in M(\mathbf{g})$ . We call  $X$  and  $X'$  two MECS which contain  $i$ . Since a MECS has at most one link in  $\mathbf{g}^M$ , players  $i \in M(\mathbf{g})$  are not connected in  $\mathbf{g}^M$ . Hence, there is no player  $j \in M(\mathbf{g})$  who belongs to  $X$  or  $X'$ . Since each MECS contains at least 3 players, there are two players  $j \notin M(\mathbf{g})$  and  $k \notin M(\mathbf{g})$  in  $X$  and two players  $j' \notin M(\mathbf{g})$  and  $k' \notin M(\mathbf{g})$  in  $X'$  such that  $jk \in A(\mathbf{g})$  and  $j'k' \in A(\mathbf{g})$ . Hence, we can use the arguments given in the proof of the previous point to show that it is not possible that player  $j$  does not have any incentive to replace the arc  $jk$  by the arc  $jk'$  and that simultaneously player  $j'$  does not have any incentive to replace the arc  $j'k'$  by the arc  $j'k$ . Consequently,  $\mathbf{g}$  is not a strict Nash network, a contradiction.

□

In the second lemma, we provide some properties of players who belong to MECS in strict Nash networks. The proof of this lemma is given in Appendix.

**Lemma 2** *Let  $\mathbf{g}$  be a strict Nash network and let  $X$  be a MECS in  $\mathbf{g}$ . Suppose  $i \in X$ ,  $j \notin X$  and  $\overline{ij} \in A(\mathbf{g})$ . Then, (a) no player  $k \in X$  sponsors an arc with  $i$  in  $\mathbf{g}$ , (b)  $ij \in A(\mathbf{g})$ , and (c)  $V_j(\mathbf{g}) = \{i\}$ .*

In the third lemma, we establish that in strict Nash networks players who belongs to MECS cannot both form several arcs and receive ones. The proof of this lemma is given in Appendix.

**Lemma 3** *Suppose that payoff function is given by equation 1 and  $\mathbf{g}$  is a strict Nash network. Let  $X$  be a MECS of  $\mathbf{g}$ . If  $i \in X$  and  $i$  is a key player, then  $i$  is the sponsor of all the arcs she is involved in.*

In Lemma 4, we establish that there are no arcs between players who belong to a MECS and players who does not belong to this MECS. The proof of this lemma is given in Appendix.

**Lemma 4** *Suppose that payoff function is given by equation 1 and  $\mathbf{g}$  is a non-empty strict Nash network. No player  $i$  in a MECS  $X$  forms an arc with a player  $j \notin X$ .*

Lemma 5 provides architectural properties of strict Nash networks. In particular, it highlights that non-empty strict Nash networks may be non-connected. The proof of this lemma is given in Appendix.

**Lemma 5** *Suppose that payoff function is given by equation 1 and  $\mathbf{g}$  is a non-empty strict Nash network. Then,  $\mathbf{g}$  is either connected, or it contains wheels and a sub-network  $\mathbf{g}_{|N \setminus W}$  where  $\mathbf{g}_{|N \setminus W}$  is either empty, or connected.*

We now provide some intuition of this result. First, we provide arguments which imply that a non-empty strict Nash network which contains no wheel is connected. Lemma 3 plays an important role to establish this result. Indeed, in a MECS which is not a wheel there is a player, say  $i$ , who has formed at least two arcs. This player cannot receive any arcs by Lemma 3. It follows that a player which is not connected with player  $i$ , say  $j$ , can imitate her strategy, and obtain the same payoff as  $i$ . Likewise, if a player, say  $i'$ , is not connected in  $\mathbf{g}$  with a player who belongs to a minimally unconfirmed sub-network and who have formed a link in  $\mathbf{g}$ , say  $j'$ , then player  $i'$  obtains a payoff higher than the payoff obtained by  $j'$  in  $\mathbf{g}$  when she forms no arc except the arc  $i'j'$ . Consequently, in a non-empty and non-connected network which contains no wheels  $\mathbf{g}$ , there always exist two players, say  $\ell$  and  $\ell'$ , who can obtain a payoff greater or equal to the payoff of the other by modifying her strategy. It follows that if  $\pi_\ell(A(\mathbf{g})) \geq \pi_{\ell'}(A(\mathbf{g}))$ , then player  $\ell'$  has an incentive to change her strategy, and if  $\pi_\ell(A(\mathbf{g})) \leq \pi_{\ell'}(A(\mathbf{g}))$ , then player  $\ell$  has an incentive to change her strategy. Therefore, a non-empty and non-connected network

$\mathbf{g}$  which contains no wheel cannot be a strict Nash network.

Let us provide arguments about the fact that a network  $\mathbf{g}$  which contains several wheels may be strict Nash. Indeed, in such a network each player who belongs to a wheel receives one arc. It follows that a player, say  $i$ , who is not connected with players in the wheel cannot obtain the same payoff as players in a wheel. Indeed, player  $i$  must form two arcs with players in a wheel to obtain confirmed resources from them while players in a wheel has formed only one arc in  $\mathbf{g}$ .

We now introduce the two main propositions about the characterization of strict Nash networks. Proposition 4 provides the architectures of connected strict Nash networks, while Proposition 5 provides the architectures of non-connected strict Nash networks.

**Proposition 4** *Suppose that payoff function is given by equation 1 and  $\mathbf{g}$  is a connected strict Nash network. Then,  $\mathbf{g}$  is (a) a minimally confirmed network where all key players are the sponsors of all arcs they are involved in, or (b) a center sponsored star.*

**Proof** Let  $\mathbf{g}$  be a connected strict Nash network. By Lemma 2 and 4 either (1)  $\mathbf{g}$  contains a MECS, say  $X$ , and all players belong to  $X$ , or (2)  $\mathbf{g}$  does not contain any MECS. We deal successively with these two cases.

1. Suppose  $\mathbf{g}$  contains a MECS, say  $X$  and all players belong to  $X$ . We show that  $\mathbf{g}$ , which is a confirmed network, is a minimal confirmed network where all key players are the sponsors of all arcs they are involved in. Suppose  $\mathbf{g}$  is a confirmed network which is not a minimal confirmed network. Then, there is a, costly, arc which can be deleted such that the resulting network is still confirmed connected. This implies that the sponsor of the arc is better off deleting the arc, hence  $\mathbf{g}$  is not a strict Nash network, a contradiction. Finally, by Lemma 3, we know that in a minimally confirmed strict Nash network, all key players are the sponsors of all arcs they are involved in.
2. The proof given here is inspired by the proof given by Bala and Goyal (Proposition 4.2, pg 1204, [2]). Suppose  $\mathbf{g}$  does not contain any MECS. It follows that  $\mathbf{g}$  contains no cycle. Since  $\mathbf{g}$  is connected, it is minimally unconfirmed. Moreover, if  $\overline{ij} \in A(\mathbf{g})$ , then there is no player  $k$  such that  $ki \in A(\mathbf{g})$  (or  $kj \in A(\mathbf{g})$ ), since  $k$  can replace the arc  $ki$  by  $kj$  ( $kj$  by  $ki$ ) and obtains the same payoff as in  $\mathbf{g}$ . It follows that if  $ji \in A(\mathbf{g})$ , then  $j$  has formed arcs with all players in  $V_j(A(\mathbf{g}))$ . Moreover, no player, except  $j$  can form arcs

with players in  $V_j(A(\mathbf{g}))$ . Consequently, player  $j$  forms arcs with all players in  $N \setminus \{j\}$  in  $\mathbf{g}$  since this network is minimally unconfirmed. It follows that  $\mathbf{g}$  is a center sponsored star.

To sum up, the only connected networks candidates to be strict Nash networks are minimally confirmed networks and center sponsored stars.  $\square$

We now highlight through an example that the payoff of several players may be asymmetric in a strict Nash network. Recall that in the standard model only one player, the central player in the center sponsored star, obtained a payoff different from the others in a non-empty strict Nash network.

**Example 3** Suppose that  $N = \{1, \dots, 7\}$  and the payoff function is given by equation 2. Moreover, suppose that  $V^C = 100$ ,  $V^U = 1$  and  $c = 10$ . Then, network  $\mathbf{g}$  in Figure 4 is a strict Nash network. In this network, all players obtain the same gross profit but players 4 and 6 incur the costs of 3 arcs, players 1 and 2 incur the costs of 1 arc and players 5 and 7 incur no cost at all.

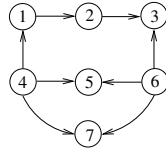

Figure 4: Network  $\mathbf{g}$

The presence of key players in our model is an interesting finding. It is similar to the role played by the central player in a center-sponsored star in the model of unconfirmed information (Bala and Goyal [2]): she incurs the cost of forming links and allows other players to be connected.

**Proposition 5** *Suppose that payoff function is given by equation 1 and  $\mathbf{g}$  is a non-empty and non-connected strict Nash network. Then,  $\mathbf{g}$  contains  $x$ ,  $x \geq 1$ , wheels and a sub-network  $\mathbf{g}_{|N \setminus \mathcal{W}}$ . Moreover,  $\mathbf{g}_{|N \setminus \mathcal{W}}$  is empty, or a minimally confirmed network where all key players are the sponsors of all arcs they are involved in.*

**Proof** Let  $\mathbf{g}$  be a non-empty and non-connected strict Nash network. We know by Lemma 5 that there is a unique sub-network,  $\mathbf{g}_{|N \setminus \mathcal{W}}$ , which is either empty, or connected. By using the

same arguments as in Proposition 4 we obtain the result:  $\mathbf{g}_{|N \setminus \mathcal{W}}$  is empty, or a center sponsored star, or a minimally confirmed network. We now show that  $\mathbf{g}_{|N \setminus \mathcal{W}}$  is not a center sponsored star. To introduce a contradiction, suppose a strict Nash network  $\mathbf{g}$  which contains both a wheel  $\mathbf{g}_{|W}$ , with  $W(\mathbf{g}) \subset \mathcal{W}(\mathbf{g})$  and a center sponsored star  $\mathbf{g}_{|N \setminus \mathcal{W}}$ . Let  $i \in N \setminus \mathcal{W}(\mathbf{g})$  be the player who forms arcs in  $\mathbf{g}_{|N \setminus \mathcal{W}}$ , let  $j \in N \setminus (\mathcal{W}(\mathbf{g}) \cup \{i\})$  be a player in the center sponsored star and let  $\ell \in W$ . By construction,  $|W(\mathbf{g})| \geq 3$ . Finally, we set  $A(\mathbf{g}') = A(\mathbf{g}) - ij + i\ell$ . We have  $\pi_i(A(\mathbf{g})) = f_1(0) + f_2(|N \setminus \mathcal{W}(\mathbf{g})| - 1) - f_3(|N \setminus \mathcal{W}(\mathbf{g})| - 1) < f_1(0) + f_2(|N \setminus \mathcal{W}(\mathbf{g})| - 2 + |W(\mathbf{g})|) - f_3(|N \setminus \mathcal{W}(\mathbf{g})| - 1) = \pi_i(A(\mathbf{g}'))$ . The inequality comes from the strict increasing property of  $f_2$ . It follows that player  $i$  does not play a strict best response and  $\mathbf{g}$  is not a strict Nash network, a contradiction. □

We provide an intuition about the fact that it is not possible that a strict Nash network  $\mathbf{g}$  contains two key players, say  $i$  and  $j$ , who belong to two distinct MECS, respectively  $X$  and  $Y$ . If such key players exist, then each of them is able to imitate the strategy played by the other. Consequently, if  $\pi_i(A_i(\mathbf{g}), A_{-i}(\mathbf{g})) \leq \pi_j(A_j(\mathbf{g}), A_{-j}(\mathbf{g}))$ , then player  $i$  obtains a higher payoff when she imitates the strategy of player  $j$ . Indeed, we have  $\pi_i(A_j(\mathbf{g}), A_{-i}(\mathbf{g})) > \pi_j(A_j(\mathbf{g}), A_{-j}(\mathbf{g})) \geq \pi_i(A_i(\mathbf{g}), A_{-i}(\mathbf{g}))$ .

We now examine an example which highlights a result (due to Lemma 5) concerning the role played by the assumption on the confirmation of information owned by the players. In contrast with the standard model designed by Bala and Goyal [2], non-empty strict Nash networks are not always connected. In other words, the introduction of the confirmation assumption may lead to strict Nash networks which are neither empty, nor connected.

**Example 4** Suppose the payoff function is given by equation 1 and  $V^C = 5$ ,  $V^U = 0.25$ ,  $c = 9$ . Suppose  $N = \{1, \dots, 6\}$  and let  $\mathbf{g}$  be such that  $A(\mathbf{g}) = \{12, 23, 31, 45, 56, 64\}$ . Then,  $\mathbf{g}$  is a non-empty strict Nash network which is not connected.

### 3.3 Strict bilateral rational networks

We begin with a lemma which shows that any acyclic component of a strict bilateral network is a center sponsored star. The proof is an adaptation of the proof given by Bala and Goyal

([2], Proposition 4.2, pg 1204).

**Lemma 6** *Suppose that payoff function is given by equation 1 and  $\mathbf{g}$  is a non-empty strict bilateral rational network. Suppose that  $\mathbf{g}_{|X}$  is an acyclic connected component of  $\mathbf{g}$ . Then,  $\mathbf{g}_{|X}$  is a center sponsored star.*

**Proof** Let  $\mathbf{g}$  be a non-empty strict bilateral rational network and let  $\mathbf{g}_{|X}$  be an acyclic connected component of  $\mathbf{g}$ . Since  $\mathbf{g}$  is a strict bilateral rational network, it is a strict Nash network. Consequently,  $\mathbf{g}_{|X}$  is minimally unconfirmed. To introduce a contradiction, suppose that  $\mathbf{g}_{|X}$  is not a center sponsored star. Suppose that player  $i$  has formed an arc with player  $j$ . No player  $\ell$  forms an arc with player  $j$  or player  $i$  in  $\mathbf{g}$ , otherwise player  $\ell$  can replace her arc  $\ell j$  (or  $\ell i$ ) by the arc  $\ell i$  (respectively  $\ell j$ ) and all players obtain the same payoff as in  $\mathbf{g}$ . Consequently,  $\mathbf{g}$  is not a strict bilateral rational network, a contradiction.  $\square$

Next lemma establishes that a strict bilateral rational network is connected. The proof of this lemma is given in Appendix.

**Lemma 7** *Suppose that payoff function is given by equation 1 and  $\mathbf{g}$  is a non-empty strict bilateral rational network. Then,  $\mathbf{g}$  is connected.*

Let us provide an intuition of this result. We showed previously that if a strict Nash network is non-connected, then there exists a component which is a wheel (see Proposition 5). We focus on the situation where a strict Nash network,  $\mathbf{g}$  contains two wheels. Let player  $i$  belongs to one wheel while player  $j$  belongs to the other one. In that case, players  $i$  and  $j$  can simultaneously improve their payoff if  $i$  replaces the arc she has formed in  $\mathbf{g}$  by an arc to the player who receives the arc of  $j$  in  $\mathbf{g}$  and if  $j$  replaces the arc she has formed in  $\mathbf{g}$  by an arc to the player who receives the arc of  $i$  in  $\mathbf{g}$ .

Since a strict bilateral rational network is a strict Nash network, Lemmas 4 and 5 are satisfied for strict bilateral rational networks. Hence we have the two following lemmas.

**Lemma 8** *Suppose that payoff function is given by equation 1 and  $\mathbf{g}$  is a strict bilateral rational network. Let  $X$  be a MECS of  $\mathbf{g}$ . If  $i \in X$  and  $i$  is a key player, then  $i$  is the sponsor of all arcs she is involved in.*



**Lemma 9** *Suppose that payoff function is given by equation 1 and  $\mathbf{g}$  is a non-empty strict bilateral rational network. No player  $i$  in a MECS  $X$  forms an arc with a player  $j \notin X$ .*

These lemmas allow us to provide the main proposition concerning strict bilateral rational networks.

**Proposition 6** *Suppose that payoff function is given by equation 1 and  $\mathbf{g}$  is a non-empty strict bilateral rational network. Then,  $\mathbf{g}$  is a center sponsored star, or a minimal cycle, or a minimally confirmed network which contains at least two key players and where all key players form arcs with the same players.*

**Proof** Let  $\mathbf{g}$  be a non-empty strict bilateral rational network.

Suppose  $\mathbf{g}$  is acyclic. Then, by Lemma 7 it is connected and by Lemma 6, it is a center sponsored star.

Suppose  $\mathbf{g}$  contains a MECS. By Lemma 7, we know that  $\mathbf{g}$  is connected and by Lemma 9 we know that there is no arc between a player who belongs to a MECS, say  $T_1(\mathbf{g})$ , and a player who does not belong to  $T_1(\mathbf{g})$ . It follows that  $\mathbf{g}$  is a minimally confirmed network. We show that if  $\mathbf{g}$  is not a minimal cycle, then (i) there exist several key players and (ii) these key players sponsor arcs with the same players.

First, we show that there are several key players in  $\mathbf{g}$ . Suppose that  $\mathbf{g}$  is a minimally confirmed network which is not a minimal cycle. Since  $\mathbf{g}$  is not a minimal cycle, there exists a player, say  $i_0$ , who is involved in at least 3 arcs in  $\mathbf{g}$ . By Lemma 8,  $i_0$  sponsors all these arcs. We now show that there exists another player, say  $j_0$ , who is involved in at least 3 arcs in  $\mathbf{g}$ . Let  $\{i_1, i_2, i_3\} \subset V_{i_0}$ . Since  $\mathbf{g}$  is a minimally confirmed network, there exist two independent chains between  $i_1$  and  $i_2$ :  $C_{i_1 i_2}^1(\mathbf{g}) = i_1, i_0 i_1, i_0, i_0 i_2, i_2$  and  $C_{i_1 i_2}^2(\mathbf{g})$ . Likewise there exist two independent chains between  $i_1$  and  $i_3$ :  $C_{i_1 i_3}^1(\mathbf{g}) = i_1, i_0 i_1, i_0, i_0 i_3, i_3$  and  $C_{i_1 i_3}^2(\mathbf{g})$ . There always exists a player, say  $j_0 \in N \setminus \{i_1\}$ , who belongs simultaneously to  $C_{i_1 i_2}^2(\mathbf{g})$  and  $C_{i_1 i_3}^2(\mathbf{g})$  otherwise player  $i_0$  obtains confirmed resources from  $i_1$  through  $i_2$  and  $i_3$  and  $\mathbf{g}$  is not a minimally confirmed network (the arc  $i_0 i_1$  is not needed). Likewise, it is worth noting that  $j_0 \notin \{i_2, i_3\}$  otherwise  $\mathbf{g}$  is not a minimally confirmed network. It follows that  $j_0$  is involved in 3 arcs: an arc which belongs to a chain  $C_{i_1 j_0}(\mathbf{g})$ , an arc which belongs to a chain  $C_{i_2 j_0}(\mathbf{g})$  and an arc which belongs to a chain  $C_{i_3 j_0}(\mathbf{g})$ . By Lemma 8, player  $j_0$  sponsors all her arcs in  $\mathbf{g}$ .

Second, we show that key players sponsor arcs with the same players. To introduce a con-

tradition, suppose that player  $i_0$  and  $j_0$  do not sponsor arcs with the same players. Since  $\mathbf{g}$  is a minimally confirmed network, there exists a chain between  $i_0$  and  $j_0$ , say  $C_{i_0, j_0}(\mathbf{g}) = i_0, i_0 j_1, j_1, \overline{j_1 j_2}, \dots, j_{m-1}, \overline{j_m j_{m-1}}, j_m, j_0 j_m, j_0$  where  $j_1 \neq j_m$ . Suppose players  $i_0$  and  $j_0$  modify their strategies: player  $i_0$  replaces the arc  $i_0 j_1$  by  $i_0 j_m$  and player  $j_0$  replaces the arc  $j_0 j_m$  by  $j_0 j_1$ . Then, we obtain the network  $\mathbf{g}'$  such that  $A(\mathbf{g}') = A(\mathbf{g}) + i_0 j_m - i_0 j_1 + j_0 j_1 - j_0 j_m$ . Players  $i_0$  and  $j_0$  obtain the same payoff in  $\mathbf{g}$  and in  $\mathbf{g}'$ : they obtain the same resources and incur the same costs in  $\mathbf{g}'$  and in  $\mathbf{g}$ . Consequently,  $\mathbf{g}$  is not a strict bilateral rational network, a contradiction.  $\square$

Strict bilateral rational networks allow to make a refinement among strict Nash networks. Indeed, the strict Nash network drawn in Figure 4 is not a strict bilateral rational network since the key players, players 4 and 6, do not sponsor arcs with the same players. We now illustrate through an example a strict bilateral rational network which is a minimal confirmed network and contains key players.

**Example 5** Suppose that  $N = \{1, \dots, 5\}$  and the payoff function is given by equation 2. Moreover, suppose that  $V^C = 100$ ,  $V^U = 1$  and  $c = 10$ . Then, network  $\mathbf{g}$  in Figure 5 is a strict bilateral rational network.

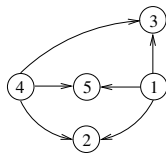

Figure 5: Network  $\mathbf{g}$

**Efficient networks.** We now turn to the issue of efficiency. Bala and Goyal showed that in the standard model, in general, an efficient network needs not to be either connected or empty (see example pg. 1205). The authors provide a partial characterization of efficient networks in this standard model. More precisely, they provide a condition which allows to obtain minimally connected networks and empty network as the only candidates to be efficient networks (Proposition 4.3, pg. 1205, [2]). They also show that, in the standard case, minimally connected networks and the empty network are the only candidates to be efficient networks

when the payoff function is linear.

In this section, we deal with efficient networks when a confirmation assumption is introduced.

**Proposition 7** *Suppose that payoff function is given by equation 1,  $f_3$  is linear and  $\mathbf{g}$  is an efficient network. Then,  $\mathbf{g}$  is a minimal base network. Moreover, if  $f_2(x+1) - f_2(x) > f_3(y+1) - f_3(y)$ , for all  $x, y \in \{0, \dots, n-2\}$ , then an efficient network is connected. Suppose in addition that  $f_1(x+1) + f_2(y-1) - (f_1(x) + f_2(y)) > f_3(z+1) - f_3(z)$ , for all  $x, z \in \{0, \dots, n-2\}$  and for all  $y \in \{1, \dots, n-2\}$ , then an efficient network is a minimally confirmed network.*

**Proof** We prove successively the three parts of the proposition.

Suppose  $\mathbf{g}$  is not a minimal base network. Then, there is a costly arc, say  $ij$  which can be deleted such that the resulting network allows to obtain the same total resources. By linearity of  $f_3$ , the distribution of links across players does not play any role on the total payoff of the players. It follows that total payoff increases when  $ij$  is deleting. Hence  $\mathbf{g}$  is not an efficient network, a contradiction.

Suppose  $f_2(x+1) - f_2(x) > f_3(y+1) - f_3(y)$ , for all  $x, y \in \{0, \dots, n-2\}$ . Then we use the same arguments as Bala and Goyal ([2], Proposition 4.3 pg. 1205): connectedness follows from the hypothesis that an additional arc to an unobserved agent is preferred by individual agents; since information flow is two-way, such an arc generates positive externalities in addition and therefore increases social welfare.

Suppose  $f_2(x+1) - f_2(x) > f_3(y+1) - f_3(y)$ , for all  $x, y \in \{0, \dots, n-2\}$  and  $f_1(x+1) + f_2(y-1) - (f_1(x) + f_2(y)) > f_3(z+1) - f_3(z)$ , for all  $x, z \in \{0, \dots, n-2\}$  and for all  $y \in \{1, \dots, n-2\}$ . The first condition implies that an efficient network is connected. The second condition implies that each player accepts to support a costly additional arc in order to obtain confirmed resources. Since these confirmed resources generates positive externalities for other players, the social welfare increases.  $\square$

We now characterize efficient networks when the payoff function is linear. At this point, we introduce a remark. In each minimally unconfirmed network, there are  $n-1$  arcs and each player obtains the unconfirmed information of each other. Hence, the total payoff obtained in such networks is  $(n-1)(nV^U - c)$  when the payoff function is linear. Likewise, in each minimal cycle there are  $n$  arcs and each player obtains the confirmed information of each other. Hence, the total payoff obtained in such networks is  $n((n-1)V^C - c)$  when the payoff function is

linear.

**Proposition 8** *Suppose that payoff function is given by equation 2 and the empty network is not efficient. Let  $\mathbf{g}$  be an efficient network. Then,  $\mathbf{g}$  is either a minimal unconfirmed network, or a minimal cycle network. Moreover, if  $n(n-1)(V^C - V^U) < c$ , then  $\mathbf{g}$  is a minimal unconfirmed network; and if  $n(n-1)(V^C - V^U) > c$ , then  $\mathbf{g}$  is a minimal cycle network.*

**Proof** Let  $\mathbf{g}$  be an efficient network. Firstly, we show that  $\mathbf{g}$  is either connected or empty. We know by Proposition 7 that an efficient network is minimal. To introduce a contradiction, suppose that  $\mathbf{g}$  is non-empty and non connected. There are two cases: either  $\mathbf{g}$  contains a cycle, or  $\mathbf{g}$  does not contain any cycle.

1. Suppose that  $\mathbf{g}$  contains a cycle, and so a MECS. We show that there is no player who does not belong to the MECS and who is directly connected with a player in the MECS in  $\mathbf{g}$ . To introduce a contradiction, suppose a MECS  $T_1(\mathbf{g})$  in  $\mathbf{g}$  which contains players  $i$  and  $j$ , with  $ij \in A(\mathbf{g})$  and let player  $\ell \notin T_1(\mathbf{g})$  such that  $i\ell \in A(\mathbf{g})$ . We define the network  $\mathbf{g}'$  as follows  $A(\mathbf{g}') = A(\mathbf{g}) - ij + \ell j$ . We have

$$W(\mathbf{g}') - W(\mathbf{g}) = 2|T_1(\mathbf{g})|(V^C - V^U) > 0.$$

Consequently,  $\mathbf{g}$  is not efficient, a contradiction. We now show that there does not exist a player  $\ell$  who is not connected to the MECS in  $\mathbf{g}$ . Again, let players  $i$  and  $j$  belong to the MECS  $T_1(\mathbf{g})$  with  $ij \in A(\mathbf{g})$ . Since  $\mathbf{g}$  is efficient, we have:

$$|T_1(\mathbf{g})|(|T_1(\mathbf{g})| - 1)V^C - |T_1(\mathbf{g})|c \geq 0 \Rightarrow (|T_1(\mathbf{g})| - 1)V^C - c \geq 0.$$

Since  $\mathbf{g}$  is not connected, there exists a player  $\ell$  who is not connected with player  $i$ . Let  $\mathbf{g}'$  be a network such that  $A(\mathbf{g}') = A(\mathbf{g}) - ij + i\ell + \ell j$ . We have

$$0 \leq (|T_1(\mathbf{g})| - 1)V^C - c < (2|T_1(\mathbf{g})| - 1)V^C - c = (|T_1(\mathbf{g})|^2 - (|T_1(\mathbf{g})| - 1)^2)V^C - c \leq W(\mathbf{g}') - W(\mathbf{g}).$$

It follows that  $\mathbf{g}$  is not efficient, a contradiction.

2. Suppose that  $\mathbf{g}$  contains no cycle. Since  $\mathbf{g}$  is non-empty, there is a component  $\mathbf{g}|_X$ ,  $|X| \geq 2$ , in  $\mathbf{g}$ . We suppose that players  $i$  and  $j$  belong to  $X$  with  $ij \in A(\mathbf{g})$ . Since  $\mathbf{g}$  is efficient, we

have

$$|X|(|X| - 1)V^U - (|X| - 1)c \geq 0 \Rightarrow |X|V^U - c \geq 0$$

Since  $\mathbf{g}$  is not connected, there is a player  $\ell \notin X$  who is not connected with  $i$ . Let  $\mathbf{g}''$  be a network such that  $A(\mathbf{g}'') = A(\mathbf{g}) + i\ell$ . We have

$$0 \leq |X|V^U - c < 2|X|V^U - c \leq W(\mathbf{g}'') - W(\mathbf{g}).$$

It follows that  $\mathbf{g}$  is not efficient, a contradiction.

Let  $\mathbf{g}$  be a non-empty network. Clearly,  $\mathbf{g}$  cannot contain more than  $n$  arcs since with  $n$  arcs it is possible to construct a minimal cycle network which allows to confirmed all the resources. Moreover,  $\mathbf{g}$  cannot contain less than  $n - 1$  arcs since it is connected.

In a minimal cycle network, the total payoff is  $n(n - 1)V^C - nc$ . Moreover, with  $n - 1$  arcs it is possible to construct a minimal unconfirmed network which allows to obtain unconfirmed information from all the players. In the latter network, the total payoff is  $n(n - 1)V^U - (n - 1)c$ . It follows that if  $n(n - 1)(V^C - V^U) < c$ , then  $\mathbf{g}$  is a minimal unconfirmed network, and if  $n(n - 1)(V^C - V^U) > c$ , then  $\mathbf{g}$  is a minimal cycle network.

□

We now examine the relationship between strict Nash networks and efficient networks when the payoff function is linear. Firstly, we establish through an example that strict Nash networks and efficient networks do not always coincide.

**Example 6** Suppose that the payoff function is given by equation 2 and  $V^C < c$ ,  $nV^U > c$  and  $V^C - V^U < c/[n(n - 1)]$ . Center sponsored stars are efficient networks. Indeed, the total payoff obtained in center sponsored stars is greater than (i) the total payoff obtained in the empty network:  $(n - 1)(nV^U - c) > 0$  since  $nV^U > c$ ; and (ii) the total payoff obtained in minimal cycles:  $(n - 1)(nV^U - c) > n((n - 1)V^C - c)$  since  $V^C - V^U < c/[n(n - 1)]$ . However, a center sponsored star is not a strict Nash network since the player who sponsors the arcs has no incentive to maintain them due to  $V^U < c$ . Finally, since center sponsored stars are not strict Nash networks, they cannot be strict bilateral rational networks.

Secondly, we provide conditions which ensure the coincidence of strict Nash networks and efficient networks when the payoff function is linear.

**Proposition 9** *Suppose that payoff function is given by equation 2.*

1. *If a minimal cycle network,  $\mathbf{g}^{mc}$ , is a strict Nash network, then  $\mathbf{g}^{mc}$  is an efficient network.*
2. *If the empty network,  $\mathbf{g}^e$ , is a strict efficient network, then  $\mathbf{g}^e$  is a strict Nash network.*
3. *Suppose  $V^U > c$  and  $V^C - V^U < c/[n(n-1)]$ . Then a center sponsored star is both a strict Nash network and an efficient network.*

**Proof** We begin with an initial observation. Consider a network  $\mathbf{g}$ . First, note that each arc in  $\mathbf{g}$  creates positive externalities. More precisely, for a given arc  $ij \in A(\mathbf{g})$ , no player, except  $i$ , can be harmed by this arc: it costs them nothing while it may add to their unconfirmed resources or upgrade their unconfirmed resources to confirmed resources. Part 1 and Part 2 of the proposition follows this observation. We now prove part 3 of the proposition.

Suppose that  $V^U > c$  and  $V^C - V^U < c/[n(n-1)]$ . Let  $\mathbf{g}^s$  be a center sponsored star where player  $j$  is the sponsor of the arcs. First, we show that player  $j$  has no incentive to remove any of her arcs in  $\mathbf{g}^s$ . If player  $j$  removes  $x$  arcs in  $\mathbf{g}^s$ , she obtains a marginal payoff equal to  $A_1 = x(c - V^U)$ .  $A_1$  is negative since  $V^U > c$ . Second, we show that it is inefficient to add arcs in  $\mathbf{g}^s$ . To introduce a contradiction, suppose that some arcs are added in  $\mathbf{g}^s$ . Then the incremental payoff associated to each of them is bounded above by  $n(n-1)(V^C - V^U) - c$ . By assumption  $n(n-1)(V^C - V^U) - c < 0$ , and we obtain a contradiction. We conclude by using the initial observation.  $\square$

## 4 Decay and Confirmation Networks

In the payoff functions used till now, we exploit the assumption that unconfirmed resources obtained through indirect arcs have the same value as that obtained through direct arcs. This assumption is strong; in general, there will be lowering of reliability, as resources is transmitted through a series of players. More precisely, if player  $i$  obtains unconfirmed resources from player  $j$  through a long sequence of intermediate players, then she should have a greater incentive to confirm information than if she obtains unconfirmed resources from player  $j$  through fewer intermediaries. Formally this is akin to requiring confirmation in Jackson and Wolinky's [11] "connections" model. To formalize this idea, define the distance  $d_{\mathbf{g}}(i, j)$  between players  $i$  and

$j$  to be the number of arcs along the shortest chain between  $i$  and  $j$  in  $\mathbf{g}$ . We denote the number of non-confirmed players at distance  $m$  from  $i$  in the network  $\mathbf{g}$  by  $n_i^m(A(\mathbf{g}))$ . The payoff of player  $i$  in  $\mathbf{g}$  is given by:<sup>16</sup>

$$\pi_i(A(\mathbf{g})) = |N_i^C(A(\mathbf{g}))| + \sum_{w=1}^{n-1} \alpha_w n_i^w(A(\mathbf{g})) - c|A_i(\mathbf{g})|. \quad (7)$$

The positive weights  $\alpha_1, \alpha_2, \dots, \alpha_{n-1}$  measure the relative importance of neighbors at different distances. We assume that  $1 > \alpha_1 \geq \alpha_2 \geq \dots \geq \alpha_{n-1}$ , so that more distant players yield less benefits. Since  $1 > \alpha_1$  each player prefers to obtain confirmed resources instead of unconfirmed ones given the number of arcs she forms. Note that the payoff function given by Equation 1 assumes that resources obtained through the network become more valuable on confirmation. However, the architecture of the network does not affect the reliability of the resources transmitted through it. By contrast, the payoff function given by Equation 7 says that unconfirmed resources obtained through many intermediary players is worth less than resources obtained through fewer intermediary players. In other words, the architecture of the network plays a role in the reliability of the resources transmitted through it. We now briefly sum up the impact of the introduction of a decay assumption in our confirmation model on equilibrium architectures.<sup>17</sup> First, under Equation 7 we can obtain a result similar to Proposition 4. In other words non-empty acyclic strict Nash networks are minimally unconfirmed networks, i.e., they are minimally connected. The intuition is the same in that linking is costly and hence leads to minimally unconfirmed networks.

Moreover, using continuity we can construct a situation similar to Example 4 where strict Nash networks are not always connected. This happens when costs of linking are high relative to confirmed information. Then it is possible to construct scenarios consisting of unconfirmed networks that are minimal. Of course when the costs of linking are lower than the benefits of a direct arc, strict Nash networks will always be connected. In fact it is easy to identify conditions that make stars strict Nash. Moreover, if  $c < \min\{\alpha_1, 1 - \alpha_2\}$ , then strict Nash networks are minimally confirmed networks. Basically if  $c < 1 - \alpha_2$ , then it is worthwhile to

---

<sup>16</sup>This function is inspired by the payoff function given by Hojman and Szeidl [10]. This payoff function generalizes the payoff function with decay introduced by Bala and Goyal [2].

<sup>17</sup>Detailed proofs for this section can be found in the working paper version at [http://bus.lsu.edu/McMillin/Working\\_Papers/pap12\\_02.pdf](http://bus.lsu.edu/McMillin/Working_Papers/pap12_02.pdf).

initiate a arc to a player who is two steps away (decay creates strong incentives to avoid long chains) allowing for confirmation. Similar results hold for bilaterally rational networks.

## Appendix

**Proof of Proposition 3.** We define three properties concerning the functions  $f_1$ ,  $f_2$  and  $f_3$ .

- (P1) for all  $x \in \{1, \dots, n-1\}$  and  $z \in \{0, \dots, n-2\}$  we have:

$$f_1(x) + f_2(n-1-x) - [f_1(0) + f_2(n-1)] < f_3(z+1) - f_3(z).$$

- (P2) for all  $x \in \{1, \dots, n-1\}$ ,  $z \in \{0, \dots, n-1\}$ , with  $x < x'$ ,  $z \leq z'$  and  $x' - x > z' - z$ , we have:

$$f_1(x) + f_2(n-1-x') - [f_1(0) + f_2(n-1)] < f_3(z') - f_3(z).$$

- (P3) We have for all  $x \in \{0, \dots, n-2\}$ :

$$f_2(x+1) - f_2(x) > f_3(x+1) - f_3(x).$$

Suppose that payoff function is given by equation 1 and  $f_1$ ,  $f_2$ ,  $f_3$  satisfy P1, P2 and P3.<sup>18</sup> To introduce a contradiction, suppose a minimally unconfirmed network  $\mathbf{g}$  which is not a Nash network. Since  $\mathbf{g}$  is a minimally unconfirmed network, it is obvious that  $\mathbf{g}$  is a base network where each player obtains  $n-1$  unconfirmed resources from others. Since  $\mathbf{g}$  is not a Nash network there exists a player, say  $i$ , who has a strict incentive to modify her strategy. Let  $E_i$  be the alternative strategy chosen by player  $i$ . There exist three kinds of alternative strategies for player  $i$  in  $\mathbf{g}$ : (a)  $|E_i| = |A_i(\mathbf{g})|$ , with  $E_i \neq A_i(\mathbf{g})$ , (b)  $|E_i| < |A_i(\mathbf{g})|$ , (c)  $|E_i| > |A_i(\mathbf{g})|$ . We deal successively with these three cases.

- (a) Suppose  $|E_i| = |A_i(\mathbf{g})|$ , with  $E_i \neq A_i(\mathbf{g})$ . There are two situations which can arise concerning the resources that player  $i$  obtains in  $\mathbf{g}'$  with  $A(\mathbf{g}') = E_i \cup A_{-i}(\mathbf{g})$ .
- Player  $i$  does not obtain confirmed resources in  $\mathbf{g}'$ . Since player  $i$  obtains  $n-1$  unconfirmed resources in  $\mathbf{g}$ , she obtains a number of unconfirmed resources smaller or equal in  $\mathbf{g}'$  than in  $\mathbf{g}$ . Moreover, player  $i$  incurs the same costs in  $\mathbf{g}$  and in  $\mathbf{g}'$ . Consequently, player  $i$  obtains a

---

<sup>18</sup>Let  $N = \{1, \dots, 9\}$  and  $f_1(x) = 2.1x + 3$ ,  $f_2(x) = 2x$ , and  $f_3(x) = x$ . These functions satisfy P1, P2 and P3.



payoff in  $\mathbf{g}'$  which is smaller or equal to the payoff she obtains in  $\mathbf{g}$ .

- Player  $i$  obtains  $x$ ,  $x > 0$ , confirmed resources in  $\mathbf{g}'$ . Since  $\mathbf{g}$  is a base network, player  $i$  obtains in  $\mathbf{g}'$  a number of unconfirmed resources equal to  $n - 1 - x'$  with  $x' > x$ . Moreover, player  $i$  incurs the same costs in network  $\mathbf{g}$  and in network  $\mathbf{g}'$ . We conclude by P2 that  $\pi_i(\mathbf{g}') - \pi_i(\mathbf{g}) = f_1(x) + f_2(n - 1 - x') - (f_1(0) + f_2(n - 1)) < 0$ .

To sum up, if  $|E_i| = |A_i(\mathbf{g})|$ , with  $E_i \neq A_i(\mathbf{g})$ , then  $E_i$  cannot strictly improve the payoff of player  $i$ .

(b) Suppose  $|E_i| < |A_i(\mathbf{g})|$ . There are two situations which can arise concerning the resources that player  $i$  obtains in  $\mathbf{g}'$  with  $A(\mathbf{g}') = E_i \cup A_{-i}(\mathbf{g})$ .

- Player  $i$  does not obtain confirmed resources in  $\mathbf{g}'$ . Since  $\mathbf{g}$  is a base network and player  $i$  forms  $|E_i| < |A_i(\mathbf{g})|$  arcs, she obtains in  $\mathbf{g}'$  a number of unconfirmed resources  $n - 1 - x'$  with  $x' \geq |A_i(\mathbf{g})| - |E_i|$ . By P3 and the fact that  $f_2$  and  $f_3$  are increasing, we have  $\pi_i(\mathbf{g}') = f_1(0) + f_2(n - 1 - x') - f_3(|E_i|) < f_1(0) + f_2(n - 1) - f_3(|A_i(\mathbf{g})|) = \pi_i(\mathbf{g})$ .

- Player  $i$  obtains  $x$ ,  $x > 0$ , confirmed resources in  $\mathbf{g}'$ . Since  $\mathbf{g}$  is a base network, player  $i$  obtains in  $\mathbf{g}'$  a number of unconfirmed resources equal to  $n - 1 - x'$ , with  $x' > x$  and  $x' - x > |A_i(\mathbf{g})| - |E_i|$ . Consequently, by P2 we have  $\pi_i(\mathbf{g}') = f_1(x) + f_2(n - 1 - x') - f_3(|E_i|) < f_1(0) + f_2(n - 1) - f_3(|A_i(\mathbf{g})|) = \pi_i(\mathbf{g})$ .

To sum up, if  $|E_i| < |A_i(\mathbf{g})|$ , then  $E_i$  cannot strictly improve the payoff of player  $i$ .

(c) Suppose  $|E_i| > |A_i(\mathbf{g})|$ . There are two situations which can arise concerning the resources that player  $i$  obtains in  $\mathbf{g}'$  with  $A(\mathbf{g}') = E_i \cup A_{-i}(\mathbf{g})$ .

- Player  $i$  does not obtain confirmed resources in  $\mathbf{g}'$ . Player  $i$  does not obtain more unconfirmed resources in network  $\mathbf{g}'$  than in network  $\mathbf{g}$ . Moreover, player  $i$  incurs higher costs in  $\mathbf{g}'$  than in  $\mathbf{g}$ . Consequently,  $E_i$  does not improve the payoff of player  $i$ .

- Player  $i$  obtains  $x$ ,  $x > 0$ , confirmed resources in  $\mathbf{g}'$ . Since player  $i$  obtains  $n - 1$  unconfirmed resources in  $\mathbf{g}$ , she obtains at most  $n - 1 - x$  unconfirmed resources in  $\mathbf{g}'$ . By P1 and the fact that  $f_3$  is increasing, we have  $\pi_i(\mathbf{g}') \leq f_1(x) + f_2(n - 1 - x) - f_3(|E_i|) < f_1(0) + f_2(n - 1) - f_3(|A_i(\mathbf{g})|) = \pi_i(\mathbf{g})$ .

To sum up, if  $|E_i| > |A_i(\mathbf{g})|$ , then  $E_i$  cannot strictly improve the payoff of player  $i$ . It follows that there does not exist any alternative strategy which allows to strictly improve the payoff of player  $i$ , a contradiction.  $\square$

**Proof of Lemma 2.** Let  $\mathbf{g}$  be a strict Nash network and let  $X$  be a MECS in  $\mathbf{g}$ . Suppose

$i \in X, j \notin X$ . We prove successively the three parts of the Lemma.

1. To introduce a contradiction suppose there is  $k \in X$  such that  $ki \in A(\mathbf{g})$ . By construction, player  $k$  does not obtain confirmed resources from player  $j$  otherwise  $X$  is not a MECS. If player  $k$  replaces the arc  $ki$  by the arc  $kj$ , she increases the number of confirmed resources by 1, and decreases the number of unconfirmed resources by 1. Therefore, player  $k$  does not play a strict best response in  $\mathbf{g}$  by Assumption (A1) and  $\mathbf{g}$  is not a strict Nash network, a contradiction.
2. To introduce a contradiction suppose that  $ji \in A(\mathbf{g})$ . Since  $i \in X$ , there is a player  $k$  such that  $k \in X$ . If player  $j \notin X$  replaces the arc  $ji$  by  $jk$ , then she obtains the same payoff as in  $\mathbf{g}$ . Consequently,  $j$  does not play a strict best response in  $\mathbf{g}$  and  $\mathbf{g}$  is not a strict Nash network, a contradiction.
3. To introduce a contradiction, suppose that there is a player  $j' \in V_j(\mathbf{g}) \setminus \{i\}$ . Clearly, there is no other chain between  $i$  and  $j'$  in  $\mathbf{g}$  than the chain  $i, \overline{ij}, j$ , otherwise  $i \in M(\mathbf{g})$  which is impossible by Lemma 1. Consequently, if player  $i$  replaces the arc  $ij$  by the arc  $ij'$ , then she obtains the same payoff as in  $\mathbf{g}$ . It follows that  $i$  does not play a strict best response in  $\mathbf{g}$  and  $\mathbf{g}$  is not a strict Nash network, a contradiction.

□

**Proof of Lemma 3.** Let  $\mathbf{g}$  be a strict Nash network. Let  $X$  be a MECS of  $\mathbf{g}$  and let  $i$  be a key player who belongs to  $X$ . Suppose player  $i$  sponsors an arc with a player  $k \notin X$ , then  $i$  has sponsored all the arcs in which she is involved by Lemma 2 (a).

Suppose now that player  $i$  is not linked with a player  $k \notin X$ . To introduce a contradiction, suppose  $i$  does not sponsor all her arcs. Then there are three distinct players, say  $j, j_1$  and  $j_2$  in  $X$ , such that  $\overline{ij}, \overline{ij_1}, \overline{ij_2} \in A(\mathbf{g})$ , where at least one of these arcs is not sponsored by player  $i$ . Without loss of generality we suppose that  $ji \in A(\mathbf{g})$ . We will show that player  $j$  has an incentive to replace the arc  $ji$  by the arc  $jj_1$ . Let  $\mathbf{g}'$  be the network such that  $A(\mathbf{g}') = A(\mathbf{g}) + jj_1 - ji$ .

First, we show that  $N_j^C(A(\mathbf{g})) \subset N_j^C(A(\mathbf{g}'))$ . To establish this result, (i) we first show that if  $k \in N_j^C(A(\mathbf{g})) \setminus N_j^C(A(\mathbf{g}'))$ , then there is a chain between  $j$  and  $k$  which does not contain any player  $j' \in V_i(\mathbf{g}) \setminus \{j\}$ . (ii) Then, we establish that in such a case, there are two independent chains between  $j$  and  $k$  in  $\mathbf{g}'$  which contradicts the assumption concerning the existence of a

player  $k$  who belongs to  $N_j^C(A(\mathbf{g})) \setminus N_j^C(A(\mathbf{g}'))$ .

(i) Suppose  $k \in N_j^C(A(\mathbf{g})) \setminus N_j^C(A(\mathbf{g}'))$ . Then, the resources of  $k$  are confirmed in  $\mathbf{g}$  by player  $j$  thanks to a chain, say  $C_{j,k}^1(\mathbf{g})$ , which contains player  $i$ . This chain also contains a player, say  $j_1 \in V_i(\mathbf{g}) \setminus \{j\}$ . We establish that there is a chain between  $j$  and  $k$  in  $\mathbf{g}$  independent from  $C_{j,k}^1(\mathbf{g})$ , say  $C_{j,k}^2(\mathbf{g})$ , which does not contain any player  $j' \in V_i(\mathbf{g}) \setminus \{j\}$ . To introduce a contradiction, suppose that such a chain does not exist, that is  $C_{j,k}^2(\mathbf{g})$  contains a player, say  $j_2 \in V_i(\mathbf{g}) \setminus \{j, j_1\}$ . In such a situation, players  $i, j_1, k, j_2$ , and  $j$  belong to a cycle in  $\mathbf{g}$ . It follows that player  $i$  (or player  $j_2$ ) has no incentive to maintain the arc  $ij_2$  (or the arc  $j_2i$ ) in  $\mathbf{g}$  and  $\mathbf{g}$  is not a strict Nash network, a contradiction.

To sum up, we know that (a) there is a chain  $C_{j,k}^2(\mathbf{g})$  which does not contain any player  $j' \in V_i(\mathbf{g}) \setminus \{j\}$ , (b) the chain  $C_{j,k}^1(\mathbf{g})$  contains player  $i$ , and (c)  $C_{j,k}^1(\mathbf{g})$  and  $C_{j,k}^2(\mathbf{g})$  are independent.

(ii) We now show that there are two independent chains between  $j$  and  $k$  in  $\mathbf{g}'$ . There are two cases: either  $C_{j,k}^1(\mathbf{g})$  contains player  $j_1$ , or  $C_{j,k}^1(\mathbf{g})$  does not contain player  $j_1$ . If  $C_{j,k}^1(\mathbf{g})$  contains player  $j_1$ :  $C_{j,k}^1(\mathbf{g}) = j, j_1, i, \overline{ij_1}, j_1, \dots, k$  in  $\mathbf{g}$ , then there is a chain between  $j$  and  $k$  in  $\mathbf{g}'$ :  $C_{j,k}^1(\mathbf{g}') = j, j_1, j_1, \dots, k$  in  $\mathbf{g}'$ . Clearly,  $C_{j,k}^1(\mathbf{g}')$  and  $C_{j,k}^2(\mathbf{g})$  are independent, so  $k \in N_j^C(\mathbf{g}')$ , that is  $k \notin N_j^C(\mathbf{g}) \setminus N_j^C(\mathbf{g}')$ : a contradiction. If  $C_{j,k}^1(\mathbf{g})$  does not contain player  $j_1$ , then it contains a player, say  $j_2$ , in  $V_i(\mathbf{g})$ :  $C_{j,k}^1(\mathbf{g}) = j, j_2, i, \overline{ij_2}, j_2, \dots, k$  in  $\mathbf{g}$ . In such a case, there is a chain between  $k$  and  $j$  in  $\mathbf{g}'$ :  $C_{j,k}^1(\mathbf{g}') = j, j_2, j_2, \overline{j_2i}, i, \overline{ij_2}, j_2, \dots, k$ .  $C_{j,k}^1(\mathbf{g}')$  and  $C_{j,k}^2(\mathbf{g})$  are independent since  $j_2 \in V_i(\mathbf{g})$ , and so  $j_2 \notin C_{j,k}^2(\mathbf{g})$ . Consequently,  $k \in N_j^C(A(\mathbf{g}'))$ , that is  $k \notin N_j^C(\mathbf{g}) \setminus N_j^C(\mathbf{g}')$ : a contradiction.

Second, since  $\overline{ij_1} \in A(\mathbf{g}) \cap A(\mathbf{g}')$ , we have  $N_j^U(A(\mathbf{g})) \subset N_j^U(A(\mathbf{g}'))$ .

Third, as the costs of each arc are the same, this implies that  $j$  is indifferent between sponsoring  $ji$  and  $jj_1$ . Since  $N_j^C(A(\mathbf{g})) \subset N_j^C(A(\mathbf{g}'))$ , it follows that player  $j$  does not play a strict best response in  $\mathbf{g}$ . This concludes the proof.  $\square$

**Proof of Lemma 4.** Let  $\mathbf{g}$  be a non empty strict Nash network which contains a MECS  $X$ . To introduce a contradiction suppose that a key player  $i \in X$  is linked with  $j \notin X$ . Since  $i$  belongs to a MECS, there exist  $i_1$  and  $i_2$  such that  $\overline{ii_1}, \overline{i_2i_1} \in A(\mathbf{g})$ . By Lemma 2,  $V_j(\mathbf{g}) = \{i\}$ ,  $ij \in A(\mathbf{g})$  and  $ii_1 \in A(\mathbf{g})$ . Let  $K$  be the number of resources of unconfirmed players that each player who belongs to  $X$  obtains in  $\mathbf{g}$ . Since  $\mathbf{g}$  is a strict Nash network player  $j$  has no

incentive to form an arc with player  $i_1$ . It follows that

$$\pi_j(A(\mathbf{g})) = f_1(0) + f_2(|X| + K - 1) - f_3(0) > f_1(|X|) + f_2(K - 1) - f_3(1) = \pi_j(A(\mathbf{g}) + j i_1) \quad (8)$$

There are two cases: either  $i_1 i_2 \in A(\mathbf{g})$ , or  $i_2 i_1 \in A(\mathbf{g})$ . We deal successively with the two cases.

1. Suppose  $i_1 i_2 \in A(\mathbf{g})$ . Player  $i_1$  cannot sponsor more than one arc otherwise she is a key player and she cannot receive an arc from player  $i$  by Lemma 3.

Since  $\mathbf{g}$  is a strict Nash network, player  $i_1$  has no incentive to remove her arc. We have:

$$\pi_{i_1}(A(\mathbf{g})) = f_1(|X| - 1) + f_2(K) - f_3(1) > f_1(0) + f_2(|X| + K - 1) - f_3(0) = \pi_j(A(\mathbf{g}) - i_1 i_2). \quad (9)$$

Due to A1, inequalities 8 and 9 are not compatible, a contradiction.

2. Suppose  $i_2 i_1 \in A(\mathbf{g})$ . There are two situations.

- Suppose that  $|V_{i_1}| = 2$ , that is  $V_{i_1} = \{i, i_2\}$ . Then, we have:

$$\pi_{i_2}(A(\mathbf{g})) = f_1(|X| - 1) + f_2(K) - f_3(|A_{i_2}|) = \pi_{i_2}(A(\mathbf{g}) - i_2 i_1 + i_2 j). \quad (10)$$

Consequently, player  $i_2$  does not play a strict best response and  $\mathbf{g}$  is not a strict Nash network, a contradiction.

- Suppose that  $|V_{i_1}| > 2$ . Then, player  $i_1$  is a key player and she cannot receive any arc by Lemma 3, a contradiction.

□

**Proof of Lemma 5.** Let  $\mathbf{g}$  be a non-empty strict Nash network.

1. First, we consider situations where  $\mathbf{g}$  contains no wheel. To introduce a contradiction suppose that  $\mathbf{g}$  is not connected. There are two situations, (i) either  $\mathbf{g}$  contains no cycle, or (ii)  $\mathbf{g}$  contains a cycle (which is not a wheel).
  - (i) Suppose  $\mathbf{g}$  contains no cycle. Since  $\mathbf{g}$  is non-empty, there are two players  $i$  and  $j$  such that  $ij \in A(\mathbf{g})$ . Since  $\mathbf{g}$  is not connected there are players  $\ell \in N \setminus \{i\}$  such that  $\ell \notin N_i^U(A(\mathbf{g}))$ . Either (i.a)  $|A_\ell(\mathbf{g})| = 0$  for all  $\ell \notin N_i^U(A(\mathbf{g}))$ , or (i.b) there exists a player  $\ell \notin N_i^U(A(\mathbf{g}))$  such that  $|A_\ell(\mathbf{g})| > 0$ .

(i.a) Suppose  $|A_\ell(\mathbf{g})| = 0$  for all  $\ell \notin N_i^U(A(\mathbf{g}))$ , that is, players  $\ell \notin N_i^U(A(\mathbf{g}))$  are isolated players in  $\mathbf{g}$ . Then there are two cases:  $\pi_i(A_i(\mathbf{g}), A_{-i}(\mathbf{g})) \leq \pi_\ell(A_\ell(\mathbf{g}), A_{-\ell}(\mathbf{g}))$  or  $\pi_i(A_i(\mathbf{g}), A_{-i}(\mathbf{g})) \geq \pi_\ell(A_\ell(\mathbf{g}), A_{-\ell}(\mathbf{g}))$ . In the first case, player  $i$  has an incentive to remove all her arcs and  $\mathbf{g}$  is not a strict Nash network. In the second case, let network  $\mathbf{g}'$  be such that  $A_\ell(\mathbf{g}') = \{\ell i\}$  and  $A_j(\mathbf{g}') = A_j(\mathbf{g})$  for all  $j \in N \setminus \{\ell\}$ . We have  $\pi_\ell(A(\mathbf{g}')) = f_1(0) + f_2(|N_i^U(A(\mathbf{g})) + 1|) - f_3(1) > f_1(0) + f_2(|N_i^U(A(\mathbf{g}))|) - f_3(1) \geq f_1(0) + f_2(|N_i^U(A(\mathbf{g}))|) - f_3(|A_i(\mathbf{g})|) = \pi_i(A(\mathbf{g})) \geq \pi_\ell(A(\mathbf{g}))$ . Consequently, player  $\ell$  does not play a strict best response and  $\mathbf{g}$  is not a strict Nash network.

(i.b) Suppose there is a player  $\ell \notin N_i^U(A(\mathbf{g}))$  such that  $|A_\ell(\mathbf{g})| > 0$ . Since  $\mathbf{g}$  contains no cycle there exist a player  $i'$ , with  $i \in N_{i'}^U(\mathbf{g})$ , and a player  $\ell'$ , with  $\ell \in N_{\ell'}(\mathbf{g})$ , who receive no arcs in  $\mathbf{g}$ . In the following we deal with players  $i'$  and  $\ell'$ . Wlog suppose that  $\pi_{i'}(A_{i'}(\mathbf{g}), A_{-i'}(\mathbf{g})) \geq \pi_{\ell'}(A_{\ell'}(\mathbf{g}), A_{-\ell'}(\mathbf{g}))$ . By the same reasoning as in the second case of point (i.a) above, we can check that player  $\ell'$  does not play a strict best response and  $\mathbf{g}$  is not a strict Nash network.

(ii) Suppose  $\mathbf{g}$  contains a cycle (which is not a wheel). Since there is a cycle, there is a MECS, say  $X$ . Moreover, since  $\mathbf{g}$  contains no wheel, the considered cycle contains a player, say  $i$ , who has formed arcs with at least two players. By Lemma 3,  $i$  receives no arcs. Since  $\mathbf{g}$  is not connected there is a player  $\ell \in N \setminus \{i\}$  such that  $i$  and  $\ell$  are not connected in  $\mathbf{g}$ . Either (ii.a)  $|A_\ell(\mathbf{g})| = 0$  for all  $\ell \notin N_i(A(\mathbf{g}))$ , where  $N_i(A(\mathbf{g})) = N_i^U(A(\mathbf{g})) \cup N_i^C(A(\mathbf{g}))$ , or (ii.b) there exists players  $\ell \notin N_i(A(\mathbf{g}))$  such that  $|A_\ell(\mathbf{g})| > 0$ . (ii.a)  $|A_\ell(\mathbf{g})| = 0$  for all  $\ell \notin N_i(A(\mathbf{g}))$ . By the same type of reasoning as in point (i.a) above we can check that player  $i$  or each player  $\ell \notin N_i(A(\mathbf{g}))$  do not play a strict best response and  $\mathbf{g}$  is not a strict Nash network.

(ii.b) Suppose there exist players  $\ell \notin N_i(A(\mathbf{g}))$  such that  $|A_\ell(\mathbf{g})| > 0$ . Either some of these players belong to a cycle (ii.b.1), or none of them belongs to a cycle (ii.b.2).

(ii.b.1) Suppose there exist players  $\ell \notin N_i(A(\mathbf{g}))$  such that  $|A_\ell(\mathbf{g})| > 0$  who belong to a cycle. In such a case, we choose a player  $\ell$  who is not connected with  $i$  in  $\mathbf{g}$ , who belongs to a cycle and who has formed arcs with at least two players. Note that  $\ell$  receives no arcs by Lemma 3. Suppose wlog that  $\pi_i(A(\mathbf{g})) \geq \pi_\ell(A(\mathbf{g}))$ . Let  $\mathbf{g}''$  be the network such that  $A_\ell(\mathbf{g}'') = A_i(\mathbf{g})$  and  $A_j(\mathbf{g}'') = A_j(\mathbf{g})$  for all  $j \in N \setminus \{\ell\}$ . We have  $\pi_\ell(A(\mathbf{g}'')) = f_1(|N_i^C(A(\mathbf{g}))| + 1) + f_2(|N_i^U(A(\mathbf{g}))|) - f_3(|A_i(\mathbf{g})|) > f_1(|N_i^C(A(\mathbf{g}))|) +$

$f_2(|N_i^U(A(\mathbf{g}))|) - f_3(|A_i(\mathbf{g})|) = \pi_i(A(\mathbf{g})) \geq \pi_\ell(A(\mathbf{g}))$ , hence player  $\ell$  does not play a strict best response, and  $\mathbf{g}$  is not a strict Nash network.

(ii.b.2) Suppose now that no player  $\ell$ ,  $\ell \notin N_i(A(\mathbf{g}))$  and  $|A_\ell(\mathbf{g})| > 0$ , belongs to a cycle. We consider such a player  $\ell$ . If  $\pi_i(A(\mathbf{g})) \geq \pi_\ell(A(\mathbf{g}))$ , then by the same reasoning as in the case (ii.b.1), we can check that player  $\ell$  does not play a strict best response and  $\mathbf{g}$  is not a strict Nash network. If  $\pi_i(A(\mathbf{g})) \leq \pi_\ell(A(\mathbf{g}))$ , then by the same reasoning as in the second case of point (i.a) above, we can check that player  $i$  does not play a strict best response and  $\mathbf{g}$  is not a strict Nash network.

2. Secondly, consider situations where  $\mathbf{g}$  contains wheels. In such a case, we focus on  $\mathbf{g}|_{N \setminus W}$ . More precisely, we use the same arguments as in the previous point to obtain the result.

□

**Proof of Lemma 7.** Let  $\mathbf{g}$  be a non-empty strict bilateral rational network. To introduce a contradiction, suppose that  $\mathbf{g}$  is not connected.

First, suppose that  $\mathbf{g}$  is acyclic. By Lemma 6, there exist two players, say  $i$  and  $j$  such that  $ij \in A(\mathbf{g})$  and  $V_j(\mathbf{g}) = \{i\}$ . Suppose that player  $\ell$  is not connected with player  $i$  in  $\mathbf{g}$ . Let  $\mathbf{g}'$  be the network where player  $i$  replaces the arc  $ij$  by the arc  $i\ell$ , that is  $A(\mathbf{g}') = A(\mathbf{g}) + i\ell - ij$ . We have:  $\pi_i(A(\mathbf{g})) \leq \pi_i(A(\mathbf{g}'))$  and  $\pi_\ell(A(\mathbf{g})) < \pi_\ell(A(\mathbf{g}'))$ , the former inequality comes from the fact that player  $\ell$  can be a non-isolated player. Consequently,  $\mathbf{g}$  is not strict bilateral rational network, a contradiction.

Second, suppose that  $\mathbf{g}$  contains a MECS, say  $X_1(\mathbf{g})$ , such that players  $i$  and  $j$  are member of  $X_1(\mathbf{g})$  and  $ij \in A(\mathbf{g})$ . Since  $\mathbf{g}$  is not connected, there exists a player  $\ell$  who does not obtain any resources from player  $i$ . We show that player  $\ell$  is not an isolated player. Indeed, if  $\ell$  is an isolated player, then we have either  $\pi_\ell(A(\mathbf{g})) \geq \pi_i(A(\mathbf{g}))$ , or  $\pi_\ell(A(\mathbf{g})) < \pi_i(A(\mathbf{g}))$ . Suppose  $\pi_\ell(A(\mathbf{g})) \geq \pi_i(A(\mathbf{g}))$ . Then,  $\mathbf{g}$  is not a strict bilateral rational network since player  $i$  should remove all her arcs to improve her payoff (this strategy will not modify the payoff of player  $\ell$ ). Suppose  $\pi_\ell(A(\mathbf{g})) < \pi_i(A(\mathbf{g}))$ . Let  $\mathbf{g}'$  be the network such that  $A(\mathbf{g}') = A(\mathbf{g}) + i\ell + i\ell - ij$ . In  $\mathbf{g}'$  player  $i$  obtains a higher payoff than in  $\mathbf{g}$  since she obtains an additional confirmed resource. Moreover, we have  $\pi_\ell(A(\mathbf{g}')) \geq \pi_i(A(\mathbf{g}')) > \pi_i(A(\mathbf{g})) > \pi_\ell(A(\mathbf{g}))$ , and  $\mathbf{g}$  is not a strict bilateral rational network.

Since  $\ell$  is not an isolated player, (i) either player  $\ell$  belongs to a MECS, (ii) or she belongs to an acyclic component. (i) Suppose player  $\ell$  belongs to a MECS, say  $X_2(\mathbf{g})$ . Then there

exist two players in  $X_2(\mathbf{g})$ , say  $i'$  and  $j'$  such that  $i'j' \in A(\mathbf{g})$ . We consider the network  $\mathbf{g}'$  such that  $A(\mathbf{g}') = A(\mathbf{g}) + ij' + i'j - ij - i'j'$ . In  $\mathbf{g}'$ , players  $i$  and  $i'$  obtain confirmed resources from all players who belong to  $X_1(\mathbf{g}) \cup X_2(\mathbf{g})$  and incur the same costs as in  $\mathbf{g}$ . Consequently, we have:  $\pi_i(A(\mathbf{g}')) - \pi_i(A(\mathbf{g})) \geq f_1(|X_1(\mathbf{g})| + |X_2(\mathbf{g})|) - f_1(|X_1(\mathbf{g})|) > 0$  and  $\pi_{i'}(A(\mathbf{g}')) - \pi_{i'}(A(\mathbf{g})) \geq f_1(|X_1(\mathbf{g})| + |X_2(\mathbf{g})|) - f_1(|X_2(\mathbf{g})|) > 0$ . The inequalities come from the fact that  $f_1$  is increasing. Consequently,  $\mathbf{g}$  is not a strict bilateral rational network, a contradiction. (ii) Suppose player  $\ell$  belongs to an acyclic component. Then by Lemma 6, player  $\ell$  belongs to a center sponsored star. We consider the player who sponsors the arcs in this center sponsored star, say  $\ell_0$ . This player has formed an arc in  $\mathbf{g}$  with a player, say  $\ell_1$ , such that  $V_{\ell_1} = \{\ell_0\}$ . Since  $f_2$  is an increasing function and the cycle contains at least three players, we have:  $\pi_\ell(A(\mathbf{g}) + \ell_0i - \ell_0\ell_1) > \pi_\ell(A(\mathbf{g}))$  and  $\pi_i(A(\mathbf{g}) + \ell_0i - \ell_0\ell_1) > \pi_i(A(\mathbf{g}))$ . Consequently,  $\mathbf{g}$  is not a strict bilateral rational network, a contradiction.  $\square$

## References

- [1] Venkatesh Bala and Sanjeev Goyal. Learning from neighbours. *Review of Economic Studies*, 65(3):595–621, July 1998.
- [2] Venkatesh Bala and Sanjeev Goyal. A noncooperative model of network formation. *Econometrica*, 68(5):1181–1230, September 2000.
- [3] Venkatesh Bala and Sanjeev Goyal. A strategic analysis of network reliability. *Review of Economic Design*, 5(3):205–228, 2000.
- [4] Pascal Billand, Christophe Bravard, and Sudipta Sarangi. On the interaction between heterogeneity and decay in two-way flow models. *Theory and Decision*. Forthcoming.
- [5] Pascal Billand, Christophe Bravard, and Sudipta Sarangi. Strict nash networks and partner heterogeneity. *International Journal of Game Theory*, 40:515–525, 2011.
- [6] Andrea Galeotti and Sanjeev Goyal. The law of the few. *American Economic Review*, 100(4):1468–92, September 2010.
- [7] Andrea Galeotti, Sanjeev Goyal, and Jurjen Kamphorst. Network formation with heterogeneous players. *Games and Economic Behavior*, 54(2):353–372, February 2006.
- [8] Mark Granovetter. *Getting a job*. Harvard University Press, 1974.

- [9] Hans Haller and Sudipta Sarangi. Nash networks with heterogeneous links. *Mathematical Social Sciences*, 50(2):181–201, September 2005.
- [10] Daniel A. Hojman and Adam Szeidl. Core and periphery in networks. *Journal of Economic Theory*, 139(1):295–309, March 2008.
- [11] Matthew O. Jackson and Asher Wolinsky. A strategic model of social and economic networks. *Journal of Economic Theory*, 71(1):44–74, October 1996.
- [12] Kris De Jaegher and Jurjen Kamphorst. Network formation with decreasing marginal benefits of information. Working Papers 08-16, Utrecht School of Economics, July 2008.
- [13] I. D. Jick. Mixing qualitative and quantitative methods: triangulation in action. *Administrative Science Quarterly*, 24:602–611, 2004.
- [14] Chongmin Kim and Kam-Chau Wong. Network formation and stable equilibrium. *Journal of Economic Theory*, 133(1):536 – 549, 2007.
- [15] S.-J. Lee and M. Gerla. Split multipath routing with maximally disjoint paths in ad hoc networks. *Proc. ICC*, 10:32013205, 2001.
- [16] G. F. Miranda, L. Vercellesi, and F. Bruno. Information sources in biomedical science and medical journalism. *Pharmacological Research*, 50:267–272, 2004.
- [17] Edmund M. Morgan. The relation between hearsay and preserved memory. *Harvard Law Review*, 40(5):712–732, 1927.
- [18] A. Tsirigos and Z. J. Haas. Analysis of multipath routingpart i: The effect on the packet delivery ratio. *IEEE Trans. Wireless Communications*, 3(1):138146, 2004.
- [19] Gary L. Wells and Elizabeth A. Olson. Eyewitness testimony. *Annual Review of Psychology*, 54(3):277–295, 2003.