

Forslund, Anders; Kolm, Ann-Sofie

Working Paper

Active labour market policies and real-wage determination - Swedish evidence

Working Paper, No. 2000:7

Provided in Cooperation with:

IFAU - Institute for Evaluation of Labour Market and Education Policy, Uppsala

Suggested Citation: Forslund, Anders; Kolm, Ann-Sofie (2000) : Active labour market policies and real-wage determination - Swedish evidence, Working Paper, No. 2000:7, Institute for Labour Market Policy Evaluation (IFAU), Uppsala

This Version is available at:

<http://hdl.handle.net/10419/82214>

Standard-Nutzungsbedingungen:

Die Dokumente auf EconStor dürfen zu eigenen wissenschaftlichen Zwecken und zum Privatgebrauch gespeichert und kopiert werden.

Sie dürfen die Dokumente nicht für öffentliche oder kommerzielle Zwecke vervielfältigen, öffentlich ausstellen, öffentlich zugänglich machen, vertreiben oder anderweitig nutzen.

Sofern die Verfasser die Dokumente unter Open-Content-Lizenzen (insbesondere CC-Lizenzen) zur Verfügung gestellt haben sollten, gelten abweichend von diesen Nutzungsbedingungen die in der dort genannten Lizenz gewährten Nutzungsrechte.

Terms of use:

Documents in EconStor may be saved and copied for your personal and scholarly purposes.

You are not to copy documents for public or commercial purposes, to exhibit the documents publicly, to make them publicly available on the internet, or to distribute or otherwise use the documents in public.

If the documents have been made available under an Open Content Licence (especially Creative Commons Licences), you may exercise further usage rights as specified in the indicated licence.



IFAU - OFFICE OF LABOUR
MARKET POLICY EVALUATION

Active labour market policies and real-wage determination – Swedish evidence

Anders Forslund, Ann-Sofie Kolm

WORKING PAPER 2000:7

Active labour market policies and real-wage determination—Swedish evidence

Anders Forslund* Ann-Sofie Kolm*

First version: April 1999; this version: November 2000

Abstract

A number of earlier studies have examined whether extensive labour market programmes (*ALMPs*) contribute to upward wage pressure in the Swedish economy. Most studies on aggregate data have concluded that they actually do. In this paper we look at this issue using more recent data to check whether the extreme conditions in the Swedish labour market in the 1990s and the concomitant high levels of *ALMP* participation have brought about a change in the previously observed patterns. We also look at the issue using three different estimation methods to check the robustness of the results. Our main finding is that, according to most estimates, *ALMPs* do not seem to contribute significantly to an increased wage pressure.

*We are grateful to Per Jansson, Bank of Sweden, Kerstin Johansson, Office of Labour Market Policy Evaluation (IFAU), Ragnar Nymoen, University of Oslo and seminar participants at IFAU, Bank of Sweden and Växjö University for comments on earlier versions of the paper. The usual caveat applies. Both authors are affiliated with the Office of Labour Market Policy Evaluation (IFAU), Box 513, S-751 20, Uppsala, Sweden, and Department of Economics, Uppsala University, Box 513, S-751 20 Uppsala, Sweden. e-mail: anders.forslund@ifau.uu.se and ann-sofie.kolm@nek.uu.se.

Contents

1	Introduction	7
2	Previous empirical studies	9
3	Theoretical considerations	11
3.1	A Simple Model	13
3.1.1	Consumers and Firms	13
3.1.2	Wage determination	15
3.1.3	Equilibrium	18
3.1.4	Active Labour Market Policy	22
4	Empirical modelling strategies	23
4.1	Static versus dynamic modelling	23
4.2	Systems versus single-equations methods	24
5	The data	26
5.1	Wages	26
5.2	Unemployment	29
5.3	Labour market programmes	29
5.4	Taxes	31
5.5	The relative price of imports	33
5.6	The replacement rate in the unemployment insurance system	33
6	Systems modelling	34
6.1	Empirical results	39
6.1.1	Identification	43
6.1.2	The long-run equations	43
6.1.3	Exogeneity	45
6.1.4	Statistical properties of the system	46
6.1.5	Sensitivity analysis	47
6.2	Concluding comments on the estimated systems	49
7	Single equations modelling	49
7.1	Introduction	49
7.2	Empirical specification of dynamic baseline model	50
7.3	Results	51
7.3.1	The point estimates	53

7.3.2	Alternative specifications of the labour market variables	58
7.4	Static modelling—canonical cointegrating regressions	62
7.4.1	Results	65
8	What accounts for the new results?	67
9	Concluding comments	70
A	The data	79
A1	Introduction	79
A1.1	A digression on data description	79
A2	Wages	80
A2.1	The nominal wage cost	80
A2.2	The product real wage	82
A2.3	Labour’s share of value added	86
A3	Unemployment	89
A4	Labour market programme participation	97
A5	Labour productivity	101
A6	Taxes	103
A6.1	Income tax rates	103
A6.2	Payroll taxes	107
A7	The relative price of imports	110
A8	The replacement rate in the unemployment insurance system	113
B	Estimating the model by <i>FIML</i> 1962–1997	115
B1	The estimated equations	115
B2	System diagnostics	115
B3	Single equation diagnostics	117

List of Figures

1	Employment and wage determination	12
2	Labour market flows	16
3	Log labour’s share of value added 1960–97	27
4	Log unemployment 1960–97	30
5	Log accommodation ratio 1960–1997	31
6	The log of the tax wedge 1960–97	32

7	Log residual income progressivity 1960–1997	33
8	Log relative price of imports	34
9	Log replacement rate in the unemployment insurance system	35
10	Unrestricted cointegrating combinations	41
11	Restricted cointegrating combinations	42
12	Actual and fitted values and scaled residuals in the dynamic system	47
13	Actual and fitted values, scaled residuals, cross plot of ac- tual and fitted values, scaled residuals and residual correl- ogram	56
14	Recursive parameter estimates	56
A1	Hourly wage cost 1961–97	81
A2	Log hourly wage cost 1961–97	81
A3	Change in log hourly wage cost 1961–97	82
A4	Log product real wage 1961–97	84
A5	Change in log product real wage 1961–97	85
A6	Log labour share of value added 1961–1997	87
A7	Change in log labour share of value added 1961–1997	87
A8	Unemployment rate (share of labour force) 1961–97	90
A9	Change in the unemployment rate 1961–97	91
A10	Log unemployment rate 1961–97	91
A11	Change in the log of the unemployment rate 1961–97	92
A12	Total unemployment rate (share of labour force) 1960–97	93
A13	Log total unemployment rate 1960–97	94
A14	Change in total unemployment rate 1961–1997	94
A15	Change in log total unemployment rate 1961–1997	95
A16	<i>ALMP</i> participation 1961–1997	98
A17	Log <i>ALMP</i> participation 1961–1997	98
A18	Change in log <i>ALMP</i> participation 1961–1997	99
A19	Accommodation ratio 1961–1997	99
A20	Log accommodation ratio 1961–1997	100
A21	Change in log accommodation ratio 1961–1997	100
A22	Log productivity in the business sector 1961–1997	101
A23	Change in log productivity in the business sector 1961–1997	102
A24	Log income tax factor 1961–1997	104
A25	Change in log income tax factor 1961–1997	104
A26	Log residual income progressivity 1961–1997	106
A27	Change in log residual income progressivity 1961–1997	106

A28	Log payroll tax factor 1961–1997	107
A29	Change in log payroll tax factor 1961–1997	109
A30	Log relative price of imports 1961–1997	111
A31	Change in log relative price of imports 1961–1997	111
A32	Log replacement rate in the unemployment insurance 1961– 1997	114
A33	Change in log replacement rate in the unemployment insur- ance 1961–1997	114

List of Tables

1	Effects of <i>ALMPs</i> on wages according to studies on aggreg- ate Swedish data	10
2	<i>ADF</i> unit root tests	28
3	Johansen tests for the number of cointegrating vectors . . .	39
4	<i>OLS</i> estimates	53
5	<i>IV</i> estimates	54
6	<i>IV</i> estimates of parsimonious model	55
7	<i>OLS</i> estimates of parsimonious model	55
8	<i>IV</i> estimates of parsimonious model with “total unemploy- ment” and accommodation ratio	59
9	<i>IV</i> estimates of parsimonious model with “total unemploy- ment” and $\log(1 - \Gamma)$	61
10	<i>CCR</i> estimates of baseline model. Dependent variable: The Product real wage rate	66
11	Estimated real wage equations from Calmfors and Forslund (1990). Dependent variable: the log of the product real wage rate	68
12	The models of Calmfors and Forslund (1990) re-estimated on new data	69
13	Estimated long-run wage-setting schedules. Dependent vari- able: Labour’s share of value added	71
A1	Normality tests for wage variables	88
A2	<i>ADF</i> tests for wage variables	88
A3	Normality tests for labour market variables	95
A4	<i>ADF</i> tests for labour market variables	96
A5	Normality tests labour productivity	102

A6	<i>ADF</i> tests for labour productivity	102
A7	Normality tests for tax variables	105
A8	<i>ADF</i> tests for tax variables	108
A9	<i>ADF</i> tests for relative import price and replacement ratio .	110
A10	Normality tests for relative import price and the replace- ment ratio	112
B1	Equation 1 for $\Delta(w - q)$	115
B2	Equation 2 for $\Delta\gamma$	115
B3	Equation 3 for $\Delta(p_I - p_p)$	116
B4	Equation 4 for $\Delta\rho$	116
B5	Correlation of residuals	116
B6	Single equation autocorrelation statistics	117
B7	Single equation normality tests	117

1 Introduction

Sweden has a long tradition of active labour market policies (*ALMPs*). The intellectual origins of modern Swedish labour market policies can be traced back to the writings of trade union economists Gösta Rehn and Rudolf Meidner in the late 1940s and early 1950s (see especially LO (1951)). During the recent recession, the volume of labour market programmes has reached unprecedented levels, peaking at almost 5% of the labour force in 1994.

The use of active labour market programmes rather than “passive” income support to the jobless can be motivated along several different lines of reasoning. To the extent that active policies improve matching between vacancies and unemployed workers, they may result in higher employment and lower unemployment; to the extent that active policies involve skill formation among the unemployed, they may improve employment prospects among the unemployed; to the extent that they improve the position of outsiders in the labour market, they may reduce wage pressure; and to the extent that they stop the depreciation of human capital among the unemployed, they may keep labour force participation up. In all these respects successful labour market policies provide a better alternative than income support for the unemployed workers.

These desirable effects may, however, come at a cost. Programmes in the form of subsidised employment may cause direct crowding out of regular employment. Moreover, to the extent that programmes actually provide a better alternative than income support for the unemployed, this may, in itself, cause unions to push for higher wages, since the punishment for higher wage demands becomes less severe if union members are better off than they would have been as unemployed workers.

The net effect of programmes on wage pressure will in general be ambiguous, simply because we have programme influences working both to lower and to raise wage pressure. In this respect, the question of the net effects on wage pressure may be said to be an empirical one. A quick glance at previous empirical studies of the effects of labour market programmes on wages, at least at the aggregate level, indicate that the wage-raising effect seems to have dominated (see *Section 2*).

Although the number of studies is fairly large, there are at least three (good) reasons to undertake yet another study.

First, most studies use data predominantly from the decades before

the 1990s, when both unemployment rates and programme participation were much lower than they have been for the last few years. To the extent that the high rates of joblessness have changed the wage setting process in the Swedish economy, there is some potential value added in performing a study on data that covers as long a period as possible of this decade. Even if the fundamental *modus operandi* of the labour market is stable, it may be that the effects of *ALMPs* vary over different phases of the business cycle. If that is the case, one can argue that estimated effects relying on data from previous decades may provide bad or no insights at all relating to the effects of *ALMPs* presently, simply because there is no earlier counterpart to the downturn of the early 1990s.

Second, a related observation is that not only the volume, but also the composition of *ALMPs* has changed in the 1990s. One potentially important change, for example, is that *relief work* no longer is the major form of subsidised employment. This may be important, because the compensation for the participants in relief work has been higher than the compensation in other programmes.

Third, there have been some recent developments in time-series methods, primarily related to the analysis of non-stationary time series. A careful application of these methods may provide new insights and enable us to check for the robustness of the results with respect to different empirical modelling strategies.

Although, given sufficient knowledge about the true data generating process (*DGP*), there generally exists an optimal way to estimate a model, the true *DGP* is of course never known in practice. This normally means that the econometrician faces a number of tradeoffs: some method, although perhaps asymptotically the most efficient one, may have bad small-sample properties; systems modelling very rapidly consumes degrees of freedom, thus limiting the number of variables it is possible to model; mis-specified dynamics may interfere with inference about long-run relations of interest and so on.

To minimise the dependence on results from a single modelling attempt (and, thus, to check the robustness of our results), we look at the data using three different estimation strategies: *first*, we estimate a long-run wage-setting relation using Johansen's (1988) full information maximum likelihood method, *second*, we estimate dynamic wage-setting equations of the error-correction type. *Finally*, we estimate a long-run wage-setting relation using canonical cointegrating regressions. This approach distin-

guishes our work from most previous studies of Swedish wage setting, that predominantly rely on single-equation methods.

Our main result is that, unlike most previous studies, we do not find that extensive *ALMPs* seem to contribute to an increased wage pressure. This may reflect that mechanisms in the Swedish labour market have changed in the face of the recent recession or that the different mix of measures used during the 1990s has made a difference. Recursive estimations do not, however, indicate any signs of significant parameter instability. To check what the difference between our results and the results in earlier studies reflect, we have conducted some sensitivity analysis. Our main conclusion from these exercises is that data revisions are the driving force.

Another important result is that we find a stable effect of unemployment (of the expected sign) on wage pressure, although our point estimates are in the lower end¹ of the spectrum defined by the results in earlier studies.

2 Previous empirical studies

Beginning with the work of Calmfors and Forslund (1990) and Calmfors and Nymoen (1990), a number of studies of Swedish aggregate wage setting have estimated effects of active labour market policies on wage setting. The results of these studies are summarised very briefly in *Table 1*. The dominating impression from the table is that, if anything, the wage-raising effect of *ALMPs* seems to dominate, although a number of the studies have come up with no significant effect in any direction.²

The entries in the table also points to the fact, stressed in the introduction, that most studies have sample periods that end before the recent recession. Common to all studies in *Table 1*, as well as a fairly large number of other studies of Swedish wage setting, is that unemployment invariably is found to exert a downward pressure on real wages; typical long-run elasticities fall between -0.04 and -0.23 .³

¹Looking at the absolute value of the estimated effect.

²There are also some studies on micro data that point to no effects or wage moderating effects of *ALMPs* (Edin, Holmlund, and Östros, 1995; Forslund, 1994). See also Raaum and Wulfsberg (1997) for an analysis with similar results for Norway using micro data.

³In international comparisons, the sensitivity of Swedish wage setters to variations

Table 1: Effects of *ALMPs* on wages according to studies on aggregate Swedish data

Study	Sample period	Effects of <i>ALMPs</i> ^a	
		Short run	Long run
Newell & Symons (1987)		0	0
Calmfors & Forslund (1990) ^b	1960–86	+	+
Calmfors & Nymoén (1990) ^c	1962–87	+	+
Holmlund (1990) ^b	1967–88	na	+
Löfgren & Wikström (1991) ^c	1970–87	+/0 ^d	0/+ ^d
Forslund (1992) ^e	1970–89	+/- ^d	+/- ^d
Forslund & Risager (1994) ^f	1970–91	0	0
Forslund (1995) ^b	1962–93	0	+
Johansson, Lundborg & Zetterberg (1999)	1965–90; 1965–98	+; 0 ^g	+; 0 ^g
Rødseth & Nymoén (1999) ^c	1966–94	0	+

^a A “+” sign indicates a significant positive effect, a “-” sign a significant negative effect and a “0” no significant effect.

^b Private sector

^c Manufacturing sector

^d Separate effects of relief work and training, respectively

^e 12 Unemployment insurance funds

^f Separate analyses of manufacturing and the rest of the private sector

^g Effects found in the shorter and longer samples, respectively

Most previous studies find that an increased tax wedge between the product real wage rate and the consumption real wage rate⁴ contributes significantly to wage pressure, both in the short run and in the long run (Bean, Layard, and Nickell, 1986; Calmfors and Forslund, 1990; Forslund, 1995; Forslund and Risager, 1994; Holmlund, 1989; Holmlund and Kolm, 1995). Two previous papers look at the effects of income tax progressivity, Holmlund (1990) without finding any significant effect and Holmlund and Kolm (1995) finding that higher progressivity gives rise to significant wage moderation.

Finally, most of the studies employ single-equation estimation methods; some using instrumental variables techniques. The more recent studies typically estimate error-correction models.

in the unemployment rate has been high, see for example Layard, Nickell, and Jackman (1991) and the survey in Forslund (1997). The latter also contains a general survey of studies of Swedish wage setting on aggregate data.

⁴This wedge reflects income taxes, payroll taxes and value-added taxes.

3 Theoretical considerations

The fact that re-employment rates for unemployed workers tend to fall over time, as is pointed out by for example, Layard, Nickell, and Jackman (1991), has put focus on *ALMPs* as a device to counteract the marginalisation of long-term unemployed workers.⁵ Active labour market policies could help maintain an efficient pool of unemployed job searchers by increasing the outsiders' search efficiency when competing over jobs. This is likely to reduce wage pressure, since the welfare of an insider is reduced in case she becomes unemployed. In addition, however, there may be an off-setting effect which tends to increase wage pressure; see for example Calmfors and Forslund (1990), Calmfors and Forslund (1991), Calmfors and Nymoén (1990), Holmlund (1990), Holmlund and Lindén (1993) and Calmfors and Lang (1995). The reason is that *ALMPs* are likely to increase the welfare associated with unemployment because, for example, current or future employment probabilities increase, or simply because the payment in programmes may be higher than in open unemployment. The study by Calmfors and Lang (1995) derives the two off-setting effects in one encompassing, although quite complex, model. The first effect can be illustrated graphically in *Figure 1* as a downward shift in the wage setting schedule (*WS*), whereas the second effect can be illustrated as an upward shift in *WS*.

Active labour market policies may, however, also affect the demand for labour. For example, *ALMPs* may affect the matching process, which in turn alters the supply of vacancies, or equivalently, the demand for labour. The matching process is, for example, likely to improve when the supply of workers becomes better adapted to the demand structure⁶ or if the search efficiency of the unemployed workers increases. Improved matching increases the speed at which a vacancy is filled. This, in turn, increases the profitability of opening vacancies, and hence more vacancies will be opened. One would, consequently, expect intensified job search assistance to have an ambiguous impact on the wage setting schedule in accordance with the earlier discussion, but have a positive impact on the demand for

⁵Although it is hard to distinguish negative duration dependence from selection as the reason behind the observed lower hazards to employment for the long-term unemployed.

⁶This aspect is closely related to the original *raison d'être* for *ALMPs* put forward by Rehn and Meidner in the 1950s

labour (an upward shift in *RES* in *Figure 1*). If one instead considers the impact of training programmes or relief jobs on the matching process, one has to account for possible locking-in effects on programme participants. Although the matching process may improve post-programme participation, evidence suggests that search efficiency and re-employment probabilities are lower for programme participants during the course of the programme than for openly unemployed; see Edin (1989), Holmlund (1990), Edin and Holmlund (1991) and Ackum Agell (1996). Hence, the impact on both the wage setting schedule and the labour demand schedule is ambiguous in this case.

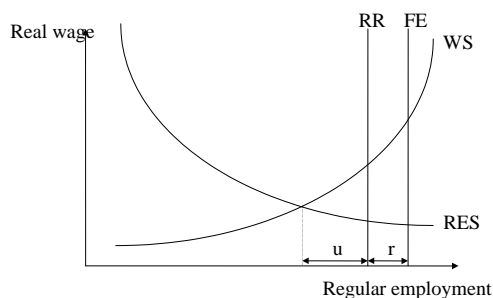

Figure 1: Employment and wage determination

ALMPs may also affect labour demand by directly reducing the number of ordinary jobs offered. Job creation schemes, like for example public sector employment schemes, and targeted wage or employment subsidies are particularly thought of as programmes that crowd out ordinary jobs. One usually distinguishes between the dead weight loss effect and the substitution effect. The dead weight loss effect refers to the hires from the target group that would have taken place also in the absence of the programme. The substitution effect, on the other hand, refers to the hires from other groups than the target group that would have taken place if the relative price between the groups had not been altered by the programme. These programmes are, hence, likely to shift the labour demand schedule downwards.⁷ An overview of the possible influences of active labour mar-

ket programmes on the employment- and wage setting schedules is given in Calmfors (1994).

We start by deriving a representation of the demand side of the labour market. Since we, in this paper, focus on the impact of *ALMPs* on wage setting behaviour, we abstract from the possibility that programmes may influence labour demand. Thereafter, we derive a wage setting schedule that captures the two off-setting effects of *ALMPs* on wage pressure that we described earlier. In an attempt to simplify the model by Calmfors and Lang (1995), we view *ALMPs* as a transition rather than as a state. The simplification is modelled in accordance with Richardson (1997). However, this model, as most models used in the previous literature, captures only some dimensions of active labour market policy. For example, to view *ALMPs* as a transition rather than as a state, suits the notion of *ALMPs* as job search assistance well. The previous literature that treats *ALMPs* as a separate state where it is time consuming to participate in a programme, captures dimensions of active labour market policies such as relief jobs. Active labour market programmes as a training device, on the other hand, is rarely modelled rigorously in the literature.⁸

3.1 A Simple Model

3.1.1 Consumers and Firms

Consider a small open economy with a fixed number of consumers with identical homothetic preferences over goods.⁹ There are k goods that are considered to be imperfect substitutes and are produced under monopolistic competition by domestic and foreign firms. The aggregate demand function facing an arbitrary domestic firm (i) can be written as

⁷Direct displacement effects of *ALMPs* in the Swedish case are discussed in Gramlich and Ysander (1981), Forslund and Krueger (1997), Forslund (1995), Sjöstrand (1997), Löfgren and Wikström (1997) and Dahlberg and Forslund (1999).

⁸There are some exceptions. Larsen (1997) deals with *ALMPs* as an instrument to maintain or increase the average productivity of the pool of unemployed workers. Binder (1997) and Fukushima (1998) take *ALMPs* as a skill up-grading device one step further by introducing heterogeneity in terms of skills. *ALMPs* provide an opportunity for low-skill workers to upgrade their skills. Fukushima finds that in addition to the two off-setting effects traced out in the basic model, there may be a “relative labour market tightness effect” which tends to increase wage demands and unemployment, when *ALMPs* are targeted towards unemployed low skilled workers.

⁹Homothetic preferences enables aggregation across consumers. Hence also foreign consumers are assumed to have homothetic preferences.

$$D_i = (I/P_c)\phi_i\left(\frac{p_1}{P_c}, \dots, \frac{p_i}{P_c}, \dots, \frac{p_k}{P_c}\right), \quad i = 1, \dots, k^d < k, \quad (1)$$

where I is the aggregate world income, p_1, \dots, p_k are the goods prices and P_c , the general consumer price index, is a linearly homogenous function of all prices.¹⁰ k^d , finally, is the number of domestically produced goods (and producers).

The technology facing the firm is given by

$$y_i = f(N_i), \quad (2)$$

where N_i is employment.¹¹ We can write the firm's real profit as

$$\Pi_i = \frac{p_i D_i}{P_c} - \frac{W_i(1+t)N_i}{P_c}, \quad (3)$$

where W_i and p_i are the firm-specific wage rate and price. The proportional payroll tax rate is denoted by t . Each firm chooses its price in order to maximise real profits, treating the wage as predetermined and considering itself to be too small to affect the general (consumer) price level. The maximisation process brings out the following price-setting rule for the firm:

$$\frac{p_i}{P_c} = \frac{\eta_i}{\eta_i - 1} \frac{W_i(1+t)}{P_c f'(N_i)}, \quad (4)$$

where η_i is the price elasticity of demand facing the firm, i.e.,

$$\eta_i = (\partial D_i / \partial p_i)|_{P_c} (p_i / D_i).$$

Note that η_i is a function of all goods' prices in terms of the general consumer price index. The price is set as a mark-up on marginal costs.

¹⁰Ignoring value-added taxes for simplicity

¹¹We suppress physical capital to simplify the exposition. This can be justified either if labour and capital are used in fixed proportions for technological reasons, or if the relative price of capital is fixed (admittedly somewhat far-fetched). A second reason to exclude capital from the theoretical exposition is that we believe that available measures of physical capital and capital prices are of such a poor quality that we do not want to use them in the empirical analysis. Thus, as the primary objective of the theoretical exposition is to lay a foundation for the empirical analysis, we concentrate on aspects we believe to be of importance for the empirical work.

To derive the firm-specific labour demand schedule, we use the fact that everything produced is also sold, i.e., we combine *equations* (1) and (2) with (4). This yields a relationship between N_i and W_i/P_c which is relevant for the wage bargaining process. It is straightforward to show that N_i is always decreasing in W_i/P_c if the second order condition for profit maximisation is to be fulfilled.

3.1.2 Wage determination

Wages are set through decentralised union–firm bargains. The bargaining model is taken to be of the asymmetric Nash variety, where the wage is chosen so as to split the gains from a wage agreement according to the relative bargaining power of the two parties involved.¹² The union’s contribution to the Nash product is given by its “rent”, i.e., $N_i(V_{Ni} - V_{sU})$, where V_{Ni} is the individual welfare associated with employment in the firm, and V_{sU} is the individual welfare associated with entering unemployment. The firm’s contribution to the Nash bargain is given by its variable real profit, Π_i .¹³ The Nash product takes the following form

$$\Omega_i = [N_i(V_{Ni} - V_{sU})]^\lambda \Pi_i^{1-\lambda}, \quad i = 1, \dots, k^d \quad (5)$$

where $\lambda \in (0, 1)$ is the bargaining power of the union relative to that of the firm.

To derive the individual welfare difference between employment in a particular firm and entering unemployment, $V_{Ni} - V_{sU}$, we need to specify the value functions associated with the different labour market states. In order to define the value functions it is, however, convenient to provide a description of the possible labour market states and the corresponding labour market flows.

Flow Equilibrium A worker will either be employed or unemployed. Employed workers are separated from their jobs at an exogenous rate s , and enter the pool of short-term unemployed workers. A short-term unemployed worker escapes unemployment at the endogenous rate α , or becomes long-term unemployed. The job offer arrival rate facing long term unemployed workers is lower than the arrival rate facing the short-term

¹²See Layard and Nickell (1990) for a more detailed presentation of the basic model.

¹³Thus, we assume that the value of not reaching an agreement is zero for the firm.

unemployed workers. A factor $c \in (0, 1)$ captures the differences in job offer arrival rates between the long- and short-term unemployed workers. *Figure 2* illustrates the flows between the three states, i.e., employment, N , short-term unemployment, U_s , and long term unemployment, U_l .

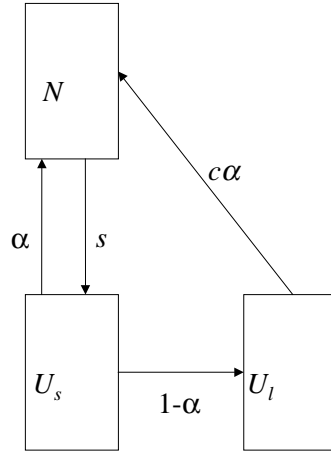

Figure 2: Labour market flows

Flow equilibrium requires that inflow equals outflow for each of the three labour market states. The flow equilibrium constraints for employment and long term unemployment can be written as

$$\begin{aligned} s(1 - U_s - U_l) &= \alpha U_s + c\alpha U_l \\ c\alpha U_l &= (1 - \alpha)U_s, \end{aligned} \quad (6)$$

which also implies a flow equilibrium constraint for short-term unemployment. The labour force is for simplicity normalised to unity, which implies that the employment and unemployment stocks are also the employment and unemployment rates. The flow equilibrium constraints in *equation (6)* define the job offer arrival rate α as a function of the overall unemployment rate, $U = U_s + U_l$, and can be written as

$$\alpha = \frac{1}{1 - c + cU/s(1 - U)}. \quad (7)$$

The Value Functions Define V_{Ni} , V_N , V_{sU} , and V_{lU} as the expected discounted lifetime utility for a worker being employed in a particular firm, employed in an arbitrary firm, short-term unemployed and long-term unemployed, respectively. The present-value functions can be written as

$$\begin{aligned} V_{Ni} &= \frac{1}{1+r} [v(W_i^c) + sV_{sU} + (1-s)V_{Ni}] \\ V_N &= \frac{1}{1+r} [v(W^c) + sV_{sU} + (1-s)V_N] \\ V_{sU} &= \frac{1}{1+r} [v(B) + \alpha V_N + (1-\alpha)V_{lU}] \\ V_{lU} &= \frac{1}{1+r} [v(B) + c\alpha V_N + (1-c\alpha)V_{lU}], \end{aligned} \quad (8)$$

where r is the discount rate, $v(\cdot)$ the instantaneous utility of being in a particular state, W_i^c the real (after tax) consumer wage for a worker employed in firm i , W^c the real (after tax) consumer wage for a worker employed in an arbitrary firm, and B the real post-tax unemployment benefit. The real consumer wage for a worker employed in firm i is represented by the expression $W_i^c = W_i/P_c - T(W_i)/P_c$, where $T(W_i)$ is tax payments. An analogous expression can be derived for a worker employed in an arbitrary firm.

Wage Setting The nominal wage is chosen so as to maximise the Nash product in *equation* (5), recognising that the firm will determine employment, i.e., $N_i = N(W_i)$. The union–firm bargaining unit considers itself to be too small to affect macroeconomic variables. The welfare difference associated with employment in a particular firm and entering unemployment, $V_{Ni} - V_{sU}$, can be derived from the equations in (8). The maximisation problem yields the following wage-setting rule:

$$(W_i^c)^\sigma = (1 - \sigma\kappa_i \cdot RIP_i)^{-1} r V_{sU}, \quad (9)$$

where we focus on the case when the instantaneous utility function is iso-elastic, i.e., $v(x) = x^\sigma$, where x is the state dependent income, i.e., W_i , W , or B . The parameter σ captures the concavity of the utility function. $\kappa_i = \lambda(1 - \omega_i)/(\lambda\varepsilon_{N_i}(1 - \omega_i) + \omega_i(1 - \lambda))$ is a broad measure of the union market power. ε_{N_i} is the labour demand elasticity and ω_i is the labour cost share, which can be rewritten in terms of the producer wage,

$W_i(1+t)/P_i$, and average labour productivity, Q_i .¹⁴ rV_{sU} contains only macroeconomic variables that are considered as given to the union-firm bargaining unit. RIP_i is the coefficient of residual income progression, i.e., $RIP_i \equiv \partial \ln W_i^c / \partial \ln W_i = (1 - T') / (1 - T/W_i)$, which defines the degree of progressivity in the income tax system. An increase in the degree of progressivity, i.e., an increase in the marginal tax rate T' relative to the average tax rate T/W_i , is hence captured by a reduction in RIP_i . *Equation* (9) suggests that an increased progressivity, for a given average tax rate, reduces the wage demands. This is in line with what has been reported in earlier studies; see for example Lockwood and Manning (1993) and Holmlund and Kolm (1995). The reason is that an increased progressivity reduces the gains from higher wages and induces unions and firms to choose lower wages in favour of higher employment.

3.1.3 Equilibrium

Price Setting We can derive the equilibrium price-setting schedule from *equation* (4) as

$$\frac{W(1+t)}{P_p} = \frac{\eta - 1}{\eta} f' \left[(1 - U) / k^d \right], \quad (10)$$

where symmetry across firms and bargaining units has been imposed, i.e., $N_i = (1 - U) / k^d$, $W_i = W$, and $p_i = P_p$, $i = 1, \dots, k^d$, where P_p is the domestic producer price index. For simplicity, all foreign firms are assumed to set the same price, i.e., $p_i = P_I$, $i = k^{d+1}, \dots, k$, where P_I is the common price set by all foreign firms. This leaves η in equilibrium as a function of the price of imports relative to the price of domestic goods, i.e., P_I / P_p .

The equilibrium price-setting schedule in *equation* (10) gives a relationship between the hourly real producer wage $W(1+t)/P_p$ and the unemployment rate U (conditional on the relative price of imports, P_I/P_p , which affects the mark-up factor). The price-setting schedule (*PS*) reflects the highest real wage producers are willing to accept at a given employment level. Hence shifts in the price-setting schedule can be referred to as changes in the “feasible wage”. The slope of the aggregate price setting schedule (*PS*) in $W(1+t)/P_p - U$ space depends on whether the technology is characterised by increasing, decreasing, or constant returns to

¹⁴ $Q_i = Y_i / N_i$, $\omega_i = W_i(1+t) / P_i Q_i$

scale. With increasing returns to scale (*IRS*) the price-setting schedule has a negative slope in $W(1+t)/P_p - U$ space, whereas the opposite holds when there is decreasing returns to scale (*DRS*). See Manning (1992) for a discussion of the case with increasing returns to scale.

Wage Setting With symmetry across wage bargaining units, i.e., $W_i = W$, we can derive the following aggregate wage-setting schedule from *equation* (9):

$$W^c = \left[1 - \frac{\kappa\sigma RIP\Delta}{(1+r+c\alpha-\alpha)} \right]^{-\frac{1}{\sigma}} B, \quad (11)$$

where the expression for rV_{sU} is obtained from the equations in (8) as

$$rV_{sU} = \frac{\alpha r + \alpha c}{\Delta} (W^c)^\sigma + \frac{(r+s)(1+r+c\alpha-\alpha)}{\Delta} (B)^\sigma,$$

where $\Delta = (1+r+s)(r+c\alpha) + (1-\alpha)s$. Recall that *equation* (7) defines α as a function of the overall unemployment rate U . The wage-setting schedule reflects wage demands at a given level of unemployment, and shifts in the wage-setting schedule can be referred to as changes in “wage pressure”. We can rewrite the wage-setting schedule in terms of the real hourly producer wage by multiplying both sides in *equation* (11) by $(1+t)P_c/P_p(1-at)$, where $at = T(W)/W$. This yields the following wage-setting schedule in terms of the product real wage rate:

$$\frac{W(1+t)}{P_p} = \theta \frac{P_c}{P_p} \left[1 - \frac{\kappa\sigma RIP\Delta}{(1+r+c\alpha-\alpha)} \right]^{-\frac{1}{\sigma}} B, \quad (12)$$

where $\theta \equiv (1+t)/(1-at)$ is the tax wedge between the product real wage and the consumer real wage. P_c will in general differ from P_p . It is easy to verify that P_c/P_p is monotonically increasing in the relative price of imports, P_I/P_p .

The wage-setting schedule in *equation* (12) gives a relationship between the real hourly producer wage $W(1+t)/P_p$ and the unemployment rate U . The relation is, however, conditioned on the relative price of imports, the average and marginal tax rates and total real aggregate demand.

By combining the aggregate price setting schedule in *equation* (10) and the aggregate wage setting schedule in *equation* (12), we can solve the model for the unemployment rate (U) and the real hourly producer wage

$(W(1+t)/P_p)$ conditional on the relative price of imports, the average and marginal tax rates and real aggregate demand.

Comparative Statics To derive comparative statics results, we differentiate the *PS*- and the *WS*-schedules in *equations* (10) and (12) with respect to the hourly real producer wage $(W(1+t)/P_p)$, the unemployment rate (U), the relative price of imports (P_I/P_p) , the real after-tax unemployment benefits (B), average labour productivity (Q), the degree of income tax progressivity (RIP), the average income tax wedge $(1-at)$, the payroll tax wedge $(1+t)$ and labour market programmes. We can conclude the following:

Price Setting

1. As previously discussed, the hourly real producer wage decreases (increases) with a higher employment rate in case the technology is characterised by *DRS* (*IRS*). Higher employment reduces (increases) the marginal product when there are *DRS* (*IRS*), which results in a lower (higher) feasible wage. Thus the slope of the *PS*-schedule is positive (negative) in $W(1+t)/P_p - U$ space if there are *DRS* (*IRS*).
2. The hourly real producer wage is unaffected by changes in the payroll tax rate (t) and average labour productivity (Q).
3. The relative price of imports will affect the price-setting schedule through the mark-up factor. However, the effect can go either way.

Wage Setting

1. The hourly real producer wage falls with a higher unemployment rate. Thus the *WS*-schedule is negatively sloped in $W(1+t)/P_p - U$ space.¹⁵ The higher the unemployment rate is, the lower will the wage pressure exerted by the bargaining units be.

¹⁵This statement is, however, based on that the effect of the real producer wage on the labour demand elasticity is not dominating the direct effect, as well as the indirect effects on the labour cost shares. Also, recall that the *WS*-schedule is conditioned on the relative price of imports, the average and marginal tax rates, and the real aggregate demand, which is the case throughout the section.

2. The relative price of imports will as a direct effect increase wage pressure. There may, however, also be an indirect effect working through the labour demand elasticity. This indirect effect can go either way.
3. The hourly real producer wage increases with more generous benefits. Thus increases in B shift the WS -schedule upward in $W(1+t)/P_p - U$ space. If we instead have an economy where after tax unemployment benefits are indexed to the average after tax wage, i.e., $B = \rho W(1-at)/P_c$, also increases in ρ increase the wage pressure.
4. An increase in average labour productivity will increase wage pressure. An increased productivity reduces the labour cost share, which in turn increases wage pressure. If the technology is iso-elastic, however, the average productivity will have no impact on wage pressure.
5. Increased tax progressivity, i.e., reductions in RIP , reduces the wage pressure. Thus, there is a downwards shift in the WS schedule in $W(1+t)/P_p - U$ space. Recall that this was also the case in partial equilibrium.
6. An increased average income tax rate will increase the real hourly producer wage. In fact, the hourly real producer wage will increase with a lower income tax wedge until the hourly consumer wage expressed in producer prices, i.e., $W(1-at)/P_p$, is unaffected. Thus, the WS -schedule shifts upwards in $W(1+t)/P_p - U$ space. However, if we have an economy where unemployment benefits are indexed to the after tax consumer wage, i.e., $B = \rho W(1-at)/P_c$, the average income tax rate will have no influence on wage pressure.
7. An increase in the payroll tax rate will increase the real hourly producer wage. In fact, the hourly real producer wage increases with a higher payroll tax wedge until the hourly consumer wage expressed in producer prices, i.e., $W(1-at)/P_p$, is unaffected. Thus the WS -schedule shifts upward in $W(1+t)/P_p - U$ space. However, if we have an economy where the unemployment benefits are indexed to the after tax consumer wage, i.e., $B = \rho W(1-at)/P_c$, the payroll tax rate will have no influence on wage pressure.
8. From 6 and 7 we can conclude that the income tax wedge and the payroll tax wedge can be expressed as a common wedge, i.e., $\theta =$

$(1+t)/(1-at)$, as is also clear from *equation* (12). Increases in θ will affect the hourly real producer wage proportionally in the case of fixed real unemployment benefits (B). With a fixed replacement ratio, however, the tax wedge has no impact on wage pressure.

9. *ALMPs* will have an ambiguous impact on wage pressure, which will be discussed more thoroughly below.

We will proceed by characterising the impact of programmes on wage pressure. The properties of the price-setting schedule will, however, obviously be crucial when determining the impact of *ALMPs* on real wages and unemployment in equilibrium.

3.1.4 Active Labour Market Policy

We will simply assume that changes in the parameter c reflect changes in *ALMPs* directed towards the long term unemployed workers. An increase in c captures an increase in the relative search efficiency of the long-term unemployed workers, which seems to be a particularly relevant way to model, for example, targeted job search assistance.¹⁶

Let *equations* (7) and (12) define the unemployment rate, U , as a function of the product real wage, $W(1+t)/P_p$, conditional on the relative price of imports, average and marginal tax rates and real aggregate demand. Note that changes in c will have a direct effect, as well as an indirect effect working through α , on the wage setting schedule. Shifts in the wage setting schedule can be traced out by differentiating *equation* (12) with respect to c and U , while taking into account that α depends on c and U through *equation* (7), holding the product real wage fixed. Rearranging the expressions, we find

$$\frac{dU}{dc} = \frac{-1}{\partial\alpha/\partial U} \left[\frac{\alpha(1-\alpha)}{(r+c)} + \frac{\partial\alpha}{\partial c} \Big|_U \right], \quad (13)$$

where

$$\frac{\partial\alpha}{\partial c} \Big|_U = \frac{-\alpha(1-\alpha)}{c} < 0 \quad (14)$$

¹⁶The model used by Calmfors and Lang (1995) allows targeting of policy towards new entrants, but not towards the truly long term unemployed, who are modelled as out of the labour force in their model.

$$\frac{\partial \alpha}{\partial U} = \frac{-c\alpha^2}{s(1-U)^2} < 0. \quad (15)$$

From expressions (13), (14) and (15) it is clear that there are two conflicting effects on the wage setting schedule following a higher c . The first term in the square brackets of *equation* (13) tends to increase the wage pressure. Higher wage demands follows because a higher c increases the welfare associated with long term unemployment. The second term captures the impact of c channelled through α . A higher c implies that the long-term unemployed compete more efficiently with the short-term unemployed for the available jobs. This reduces the value of short-term unemployment; lower wage demands follow as a consequence.¹⁷

One can, however, note that the size of the discount rate is crucial in determining which of the two effects that will dominate in this simplified framework. When the future is discounted, i.e., $r > 0$, the impact on welfare associated with short-term unemployment will dominate over the impact on welfare associated with long term unemployment. Thus, wage demands will be reduced due to the higher competition over jobs facing an employed worker in case of unemployment. In this model, *ALMPs* that increase the search efficiency of all unemployed workers, will have no influence on wage pressure and unemployment.

4 Empirical modelling strategies

The main focus in this paper is on wage setting. Thus, our primary interest lies in finding a structural relationship between the factors influencing the behaviour of wage setting agents and the outcome, in our case a bargaining outcome, in terms of a desired real wage rate. The issue is how to model such a structural equation. This issue, in turn, involves a lot of decisions. Below, we will outline a number of such issues and motivate the decisions we have made.

4.1 Static versus dynamic modelling

The theoretical framework outlined above is static, in the sense that we focus on the steady state equilibrium of the model. Hence, our theor-

¹⁷Note that a $c < 1$ is not necessary to generate the two off-setting effects.

etical predictions pertain to steady-state effects. There are, however, a number of good reasons to believe that what we observe in our data may involve a mix of equilibria and adjustments to such equilibria.¹⁸ Lacking explicit predictions about the dynamic paths of variables, we mainly use our theoretical model to suggest (testable) restrictions defining equilibria, whereas we let the dynamics be suggested by the data.

An alternative would be to *impose* rather than to test the equilibrium model, and use some estimator that is consistent in the presence of non-Gaussian error terms. A drawback with this approach in our case is that preliminary tests indicate that most of the variables of interest may be non-stationary. Valid inference requires stationarity, which in our case would imply estimating on differenced data. This, in turn, destroys valuable long-run information in the data.

A second alternative would, of course, be to derive dynamics from theory. We are, however, inclined to believe that whereas good theory may be informative about long-run equilibrium relationships among variables, this is not so to the same extent when it comes to dynamics.

Our modelling strategy is, therefore, to extract long-run equilibrium information from the data by looking for theory-consistent cointegrating vectors, and in addition to extract short-run information on dynamic adjustments by estimating error-correction models.

4.2 Systems versus single-equations methods

The first generation of studies employing error-correction techniques relied on single-equation methods. Recently, systems methods have become increasingly popular, in part because of advances in econometric theory¹⁹, in part because systems methods have become available in standard time-series econometrics packages.²⁰ Both approaches have their pros and cons.

The main drawback of systems modelling is that the short samples available in most applications (including ours) put a severe constraint on the number of variables that can be modelled. We could without problems, using our theoretical framework and previous empirical studies of wage

¹⁸Such reasons include costs of adjustment and time aggregation, which we have not modelled explicitly.

¹⁹Some useful references are Johansen (1988), Banerjee, Dolado, Galbraith, and Hendry (1993), Hendry (1995) and Johansen (1995).

²⁰Such as EViews, PcFiml, Rats and TSP.

setting, motivate the inclusion of more than 10 variables in the analysis. Given 38 annual observations, such an analysis is simply not feasible. Thus, only a subset of the *a priori* interesting variables can be modelled consistently as a system. We describe below how we chose our subset. The systems approach, however, also has important advantages.

First, it provides a consistent framework for finding the number of long-run relations (cointegrating vectors) among a set of variables. Moreover, since the cointegrating vectors are not uniquely determined by data alone, the analyst is forced to make explicit assumptions to identify them. These assumptions imply restrictions, which are testable.

Second, a major problem with the single-equations approach is that one has to rely on assumptions about exogeneity that are either not tested (in the case of *OLS* estimation) or hard to test (instrumental variables, *IV*, estimation).²¹ In the framework of a system, on the other hand, exogeneity tests are an integral part of the estimation procedure. Actually, one possible outcome of the systems approach is that it may be shown that *OLS* can be applied to the equation of interest without loss of information. The results of the systems modelling, employing Johansen's (1988) *FIML* methods are presented in *Section 6.1*.

Because of the constraints with respect to the number of variables that can be included in the systems modelling, we also estimate (by *IV* methods) single-equation error-correction models of wage setting. In addition to permitting a larger number of potentially important variables, this approach also allows us to estimate the model recursively. This, in turn, provides important information on parameter (in)stability. This sheds light on the questions raised in the introduction relating to possible changes in i.a. the sensitivity of wage setters to labour market conditions such as unemployment and *ALMPs*. The estimated error-correction models are presented in *Section 7.3*.

Both systems methods and single-equation error-correction models rely on correctly specified dynamics for reliable inference about long-run relationships.²² Park (1992) suggests a way to estimate cointegrating relation-

²¹Exogeneity can mean a lot of things. Here it, somewhat loosely, refers to the following situation: In the model $y_t = a_0 + a_1 x_t + \varepsilon_t$, x_t is said to be *weakly exogenous* with respect to the parameter a_1 if correct inference about it can be drawn without modelling x_t .

²²Given correctly specified dynamics, the methods also, obviously, provide information on the dynamics of the wage-setting process.

ships, canonical cointegrating regressions, that employs non-parametric methods to transform the data in a way that allows valid inference based on *OLS* regressions on the transformed data. The method and the results derived by it are presented in *Section 7.4*.

5 The data

Our data set consists of annual data over the period 1960–1997. We use annual data partly to cover as long a time span as possible in order to be able to analyse long-run properties of the variables, partly because there is no variation during a year in some of our variables (for example the income tax rates) and partly to avoid the measurement errors present in higher-frequency series. In this section, we provide data definitions and sources and some descriptive statistics related to the properties of the series used in the empirical study.²³

5.1 Wages

The nominal hourly wage measure used pertains to the business sector and is generated as the ratio between the total wage sum (including employers' contributions to social security, henceforth called payroll taxes) and the total number of hours worked by employees in the business sector. To get the product real wage, the wage series is deflated by a measure of producer prices. The price series used is the implicit deflator for value added in the business sector at producer prices. The log of the product real wage is denoted by $w - p_p$. Finally, to get the measure of labour's share of value added, which is what we end up using in most of the empirical work, we divide the product real wage rate by average labour productivity.²⁴ The latter variable is derived by dividing real value added in the business sector by the total number of hours worked (including the hours worked by employers and self-employed). The data are taken from the National Accounts Statistics.²⁵ The use of the National Accounts Statistics is dic-

²³A more thorough data description is given in *Appendix A*.

²⁴We use this variable instead of the product real wage for two reasons. *First*, we have an urgent need to keep the number of variables down because of our wish to estimate a system. *Second*, several empirical studies of Swedish wage setting have tested the implied restriction on the effect of productivity on wages without rejecting it (see for example Forslund (1995); Rødseth and Nymoen (1999)).

tated by our wish to cover the whole business sector, for which no direct measure of the hourly wage rate is available for our period.

The (natural) logarithm of labour’s share of value added, $(w - q)$,²⁶ is plotted in *Figure 3*. The series is upward trended from the early 1960s to the early 1980s. Following the two devaluations in 1981 and 1982 as well as in the aftermath of the depreciation of the *Krona* in the early 1990s, the share falls very rapidly. Unit-root tests reported in *Table 2* suggest that the labour share of value added may be an $I(1)$ variable.²⁷



Figure 3: Log labour’s share of value added 1960–97

²⁵Numbers from reports N 1975:98, N1981:2, N 10 1985 and N 10 1997 from Statistics Sweden have been chained. This procedure has been followed for all series based on the National Accounts. All data for 1997 are taken from preliminary figures published by the National Institute for Economic Research (Analysunderlag våren 1998).

²⁶We use lower-case letters to denote logarithms of the corresponding variables.

²⁷We are well aware that single-equation unit-root tests can at best be indicative, and we do not suggest that certain variables “are”, for example, first-order integrated.

Table 2: *ADF* unit root tests

Variable	# lags	Trend included	t-statistic	Critical value
Log labour share of value added	1	yes	-2.443	-3.547
Log labour share of value added	1	no	-2.224	-2.953
Change in log labour share of value added	0	yes	-4.410**	-3.551
Change in log labour share of value added	0	no	-4.369**	-2.953
Log unemployment rate	1	yes	-3.018	-3.547
Log unemployment rate	1	no	-1.489	-2.953
Change in log unemployment rate	1	yes	-4.479**	-3.551
Change in log unemployment rate	1	no	-4.453**	-2.953
Log accommodation rate	0	yes	-1.999	-3.547
Log accommodation rate	0	no	-2.333	-2.953
Change in log accommodation rate	3	yes	-4.365**	-3.551
Change in log accommodation rate	0	no	-6.141**	-2.953
Log tax wedge	0	yes	-1.442	-3.547
Log tax wedge	0	no	-2.460	-2.953
Change in log tax wedge	0	yes	-5.286**	-3.551
Change in log tax wedge	0	no	-4.722**	-2.593
Log relative import price	0	yes	-1.600	-3.528
Log relative import price	0	no	-1.484	-2.938
Change in log relative import price	0	yes	-5.276**	-3.531
Change in log relative import price	0	no	-5.351**	-2.94
Log replacement rate	5	yes	-0.498	-3.556
Log replacement rate	5	no	-1.828	-2.956
Change in log replacement rate	2	yes	-6.630**	-3.551
Change in log replacement rate	2	no	-6.287**	-2.953
Log residual income progressivity	5	yes	-2.551	-3.547
Log residual income progressivity	5	no	-1.616	-2.953
Change in log residual income progressivity	2	yes	-7.901**	-3.551
Change in log residual income progressivity	2	no	-7.917**	-2.953

5.2 Unemployment

The number of unemployed persons is the standard measure given by the Labour Force Surveys (*LFS*) performed by Statistics Sweden.²⁸ This number of persons is turned into an unemployment rate by relating it to the labour force. The measure of the labour force is not the one supplied by the *LFS*. Instead, the labour force is derived as the sum of employment according to the National Accounts Statistics, unemployment according to the *LFS* and participation in active labour market policy measures (*ALMPs*) according to statistics from the National Labour Market Board.²⁹ This “non-standard” definition of the labour force is used first because the *LFS* measure is not available prior to 1963 and second because it seems natural to include programme participants in the measure of the labour force, as active job search and joblessness are necessary conditions for programme eligibility.

The log of the unemployment rate, u , is graphed in *Figure 4*³⁰. The variation in the unemployment rate is completely dominated by the dramatic rise in the early 1990s. Prior to this the series exhibits a clear cyclical pattern with every peak slightly higher than its predecessor. Looking at *Table 2*, we see that unit roots cannot be rejected, even allowing for a deterministic trend, whereas they are rejected for the series in first-difference form. This would indicate that the (logged) unemployment rate behaves like an $I(1)$ series in our sample period. It is, however, important to remember that the failure to reject the null of non-stationarity does not entail accepting a unit root; it may, for example, reflect other forms of non-modelled non-stationarity such as regime shifts.

5.3 Labour market programmes

The programmes include the major ones administered by the National Labour Market Board. Until 1984 these are *labour market training* and

²⁸Due to changes in both definitions and methods of measurement, there are breaks in the *LFS* unemployment series. The present series is chained by multiplying the old series by the ratio between it and the new one at common observations.

²⁹Only those programme participants who are not included among the employed are, of course, added.

³⁰We use the logarithmic transformation both because this potentially makes the normal distribution a better approximation and, more fundamentally, because the log form is consistent with a hypothesis about the marginal effect on wages from a rise in unemployment from 1% to 2% being larger than a rise from 9% to 10%.

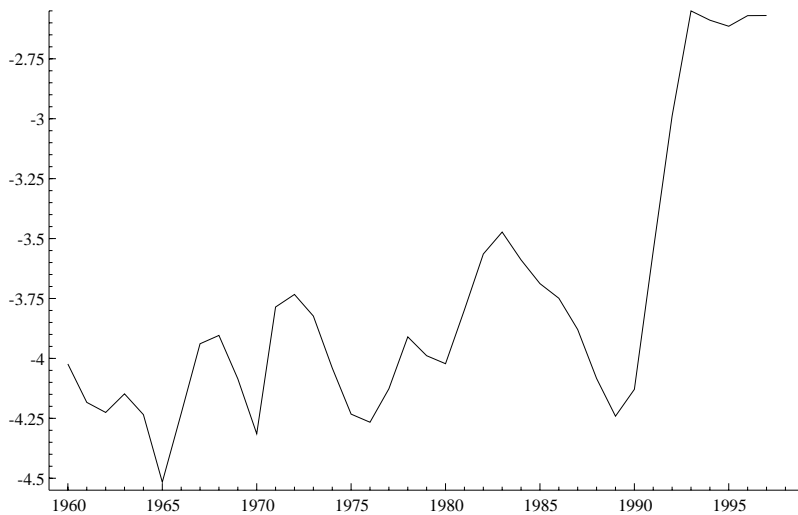

Figure 4: Log unemployment 1960–97

relief work. In 1984 *youth programmes* and *recruitment subsidies* are added. During the 1990s a vast number of new programmes were introduced. Of these, we have included *training replacement schemes*, *workplace introduction (API)* and *work experience schemes (ALU)*. The source of all data on *ALMPs* is the National Labour Market Board. The variable used to represent *ALMPs* is the *accommodation ratio*, which relates the number of programme participants to the sum of open unemployment and *ALMP* participation. The log of the accommodation rate, γ , is displayed in *Figure 5*. The series shows a steep upward trend until the late 1970s, then varies cyclically over the 1980s and falls sharply from the late 1980s, despite the fact that the number of participants reached an all times high during this period. Unit root tests reported in *Table 2* fail to reject a unit root in the (logged) levels, whereas unit roots are forcefully rejected in the logarithmic difference series, leading us to treat the variable as potentially $I(1)$.

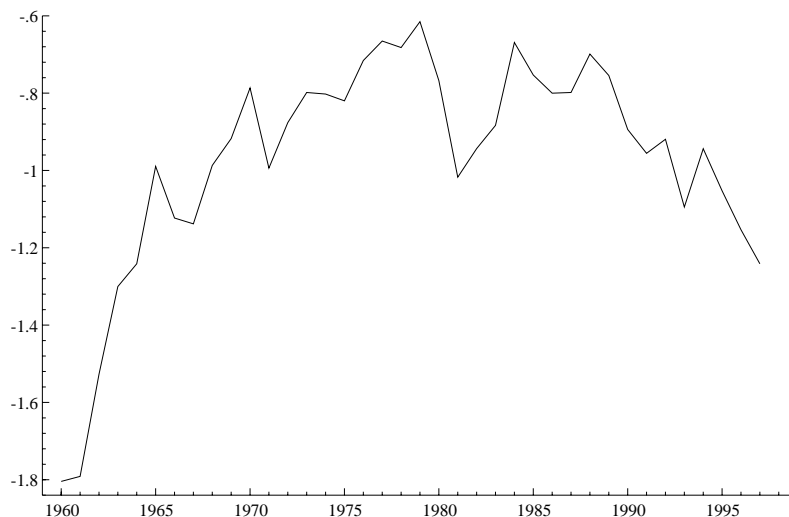

Figure 5: Log accommodation ratio 1960–1997

5.4 Taxes

The taxes in our data set are income taxes, payroll taxes and indirect taxes, i.e., the tax components of the tax-price wedge between product and consumption real wages. There are many possible ways to compute taxes, so we go into some detail in *Appendix A* to describe how ours have been derived. The income tax rate is computed for the tax brackets corresponding to the average annual labour income in the business sector according to the National Accounts Statistics to achieve consistency with the wage measures used. The payroll tax factor³¹ is computed as the ratio between the total wage bill in the business sector according to the National Accounts Statistics, including and excluding employers' contributions. Finally, the indirect tax factor³² is computed as the ratio between value added in the business sector at market prices and at producer prices according to the National Accounts Statistics.

The log of the tax wedge, defined as $\theta \equiv \log(1 + t) + \log(1 + VAT) -$

³¹This factor equals $1 + t$.

³²The indirect tax factor equals $1 + VAT$.

$\log(1 - at)$, where t is the payroll tax rate, VAT the indirect tax rate and at the average income tax rate, is plotted in *Figure 6*. The wedge increases almost monotonically until the tax reform of the early 1990s, when it falls considerably and then stays fairly constant. Unit root tests in *Table 2* (with and without trend included) do not reject the null of a unit root in levels, whereas the first difference seems to be stationary. Also in this case, thus, the series will be treated as potentially $I(1)$.



Figure 6: The log of the tax wedge 1960–97

We have also computed a point estimate of marginal income tax rates pertaining to the tax bracket at which the average tax rate is computed. This marginal tax rate is used to derive our measure of progressivity in the income tax system, the coefficient of residual income progressivity, RIP .

The logged series is plotted in *Figure 7*. Progressivity remained fairly unchanged from the beginning of our sample period until the early 1970s, when it increased rapidly for a number of years. This increase was halted in 1978, when a steady decrease in progressivity culminated in the 1991 tax reform, when most progressivity was removed. Since then, little has happened. The series is serially correlated, but almost all serial correlation is removed by first-differencing. The ADF tests in *Table 2* do not reject a unit root in the series.



Figure 7: Log residual income progressivity 1960–1997

5.5 The relative price of imports

In addition to taxes, the wedge between the product real wage and the consumption real wage reflects the relative price of imports. We measure this variable by the implicit deflator of imports relative to the implicit deflator of value added at producer prices according to the National Accounts Statistics.

The (log) relative price of imports, $p_I - p_p$, plotted in *Figure 8*, first falls until 1972. The first oil price shock pushes the relative price steeply upwards, and subsequently, the devaluations of the late 1970s and early 1980s coincide with a continuous rise. This is reversed after the devaluation in 1982, after which domestic prices rise faster than import prices for 10 years. Finally, the depreciation of the *Krona* in 1990s accompanies a reversal of this trend. The unit root tests in *Table 2*, which reject for the differenced series but not for the series in logs, suggest that it may be appropriate to treat the relative price of imports as first-order integrated.

5.6 The replacement rate in the unemployment insurance system

The final variable modelled in our system is the replacement rate in the unemployment insurance system. We measure it by the maximum daily



Figure 8: Log relative price of imports

before-tax compensation, converted into an annual compensation, in relation to the average annual before-tax labour income in the business sector³³. Without going into too much details (which are given in *Appendix A*), we just want to point out that this implicitly assumes that the representative union member is entitled to the maximum level of compensation, which according to rough calculations seems reasonable.

The log of the replacement rate, ρ , is reproduced in *Figure 9*. The replacement rate, according to our measure, shows a trend wise increase until the early 1990s, after which point it decreases rather rapidly. It can also be noted that the variations around the trend are quite large. Once more, unit root tests reported in *Table 2* indicate that the series may be $I(1)$.

6 Systems modelling

Our general approach to the empirical modelling is to start out from an unrestricted vector-autoregressive (*VAR*) representation of the variables we study. Two critical choices have to be made. *First*, which variables should be included, and *second*, which lag length should be chosen.³⁴ In

³³As computed from the National Accounts Statistics.

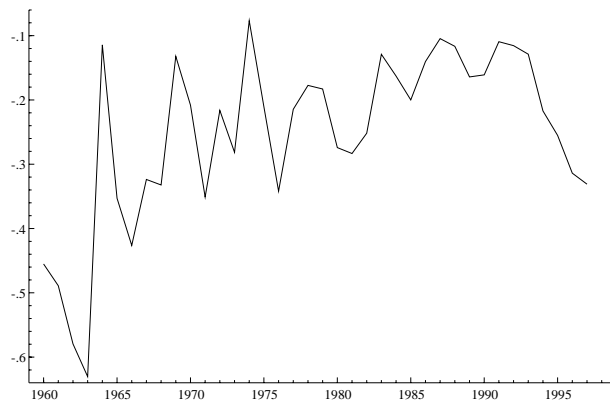

Figure 9: Log replacement rate in the unemployment insurance system

the first of these respects, we have mainly been guided by our theoretical framework, but also, to some extent, by previous empirical studies of Swedish aggregate wage setting. The determination of the lag length is discussed below.

The model presented in *Section 3.1* gave rise to two equilibrium relationships between the real wage rate and unemployment: the wage-setting (*WS*) schedule and the price-setting (*PS*) schedule.

The discussion of the properties of the price-setting schedule in *Section 3.1.3* suggested that price setters potentially would respond to the unemployment rate and the relative price of imports, but that the signs of the responses would be indeterminate:

$$w - p_p = f(\overset{?}{u}, (\overset{?}{p_I} - p_p)), \quad (16)$$

where lower-case letters denote (natural) logarithms of the corresponding upper-case letters and the question marks denote the uncertainty of the sign of the effect. One further result from the theoretical analysis was that the price-setting schedule is unaffected by changes in average labour productivity and the tax wedge between product and consumption real wages. Also notice that *equation (16)*, as long as the effect of the relative import price is non-zero, can be renormalised as

$$p_I - p_p = F(u, w - p_p) \quad (17)$$

The corresponding results for the wage-setting schedule are summarised in the following equation:

$$w - p_p = g(\bar{u}, (\overset{+(?)}{p_I} - p_p), \overset{+}{\rho}, \overset{+}{q}, \overset{+}{RIP}, \overset{+}{\theta}, \overset{?}{\gamma}). \quad (18)$$

Notice that this formulation means that, when we look at the effects of increased *ALMP* participation, we condition on the open unemployment rate, thus implicitly assuming that increased *ALMP* participation means either decreased employment or a smaller number of persons outside the labour force. This is in some contrast to a number of previous studies,

³⁴There could, in principle, also be a third choice, if one is willing to *assume* weak exogeneity of some variables already at the outset. Then one would have to decide which variables could be treated as weakly exogenous (non-modelled) in the system. We did some experimentation along these lines, but almost always ended up with systems with badly behaved residuals.

where instead “total” unemployment (the sum of openly unemployed and programme participants) has been held constant. In those studies, the implicit assumption is that increased programme participation exactly corresponds to a decrease in open unemployment. It is not *a priori* clear which of these formulations is the more “reasonable” one.

Counting the variables appearing in these two equations, we arrive at 8 variables to model in a system. This calls for some restrictions prior to further modelling, especially as we want to include a time trend in the system to allow for deterministic trends in the data.

The *system*, often called the *unrestricted reduced form (URF)*, is the starting point of the empirical analysis. It can be written (assuming two lags, which is what we started out from)

$$\mathbf{y}_t = \pi_1 \mathbf{y}_{t-1} + \pi_2 \mathbf{y}_{t-2} + \mathbf{v}_t, \mathbf{v}_t \sim \mathbf{IN}_n[\mathbf{0}, \mathbf{\Omega}], \quad (19)$$

where \mathbf{y}_t is an $(n \times 1)$ vector of observations at time $t = 1 \dots T$ of the endogenous variables. This system basically serves as a baseline model against which to test restrictions. For such testing to be valid, it is essential that the residuals are well behaved. The strategy then is to include the number of lags necessary to produce such residuals. Given our sample, where we have $T = 38$, it is fairly obvious that we have to restrict the number of variables entering \mathbf{y} severely in order to have enough degrees of freedom for testing for the properties of the residuals. The restriction we choose to impose is to model the labour share of value added $(w - q)$ ³⁵ instead of the product real wage rate, thus imposing a coefficient of unity on productivity in both the price-setting schedule and the wage-setting schedule. This is primarily motivated by appealing to earlier studies of wage setting and to the “stylised fact” that the labour share seems to be independent of productivity in the long run.³⁶ To perform the necessary diagnostic tests, we must reduce the system. At this stage we let the data tell us which further variable to take out of the system, simply by demanding a system with well-behaved residuals.³⁷ By this route we end up in a system consisting of $(w - q), u, \gamma, (p_I - p_p), \theta, \rho$ and a time trend.

³⁵We denote the labour share by $w - q$ rather than by $w - p_p - q$.

³⁶This is, e.g., discussed in Layard, Nickell, and Jackman (1991).

³⁷The maximum number of variables followed because we decided, *a priori*, to estimate a baseline system with two lags. All estimations have been performed in PcFiml 9.2, see Doornik and Hendry (1997).

This system with two lags marginally passes the diagnostic tests (there is almost significant autocorrelation and non-normal errors). We then proceed to test for the significance of the second lag, and the restriction $\boldsymbol{\pi}_2 = 0$ is just about accepted by the data. There is no significant autocorrelation in the restricted system³⁸, but the residuals are significantly non-normal. However, we decide to take this as our baseline system (including the trend, which, according to the tests, is highly significant).

In the single-equation unit root tests reported, we found indications that all six variables behave like they are first-order integrated ($I(1)$). Thus, the next step is to apply the Johansen procedure to test for the number of cointegrating vectors. We begin by rewriting *equation* (19) as (imposing $\boldsymbol{\pi}_2 = 0$)

$$\Delta \mathbf{y}_t = \mathbf{P}_0 \mathbf{y}_{t-1} + \mathbf{v}_t, \quad (20)$$

where $\mathbf{P}_0 = \boldsymbol{\pi}_1 - \mathbf{I}_n$ is a matrix containing long-run relations between the variables.³⁹ Write $\mathbf{P}_0 = \boldsymbol{\alpha}\boldsymbol{\beta}'$. If the rank, p , of this matrix is n , then \mathbf{y}_t is stationary; if $p = 0$, then $\Delta \mathbf{y}_t$ is stationary, all elements of \mathbf{y}_t are non-stationary and there exists no stationary linear combination of them. If $0 < p < n$, there are p stationary linearly independent linear combinations of \mathbf{y}_t , and both $\boldsymbol{\alpha}_{(n \times p)}$ and $\boldsymbol{\beta}'_{(p \times n)}$ have rank p . Thus, the problem of finding the number of cointegrating vectors consists of finding the rank of \mathbf{P}_0 .

It is fairly obvious that the wage-setting schedule is not identified without further parameter restrictions.⁴⁰ It may still, however, be the case that the model is identified in an empirical sense: the data may accept further restrictions on parameters that actually identifies the model. What we would need is something that shifts the price-setting schedule without affecting the wage-setting schedule. We report the results of our efforts in that direction in *Section* 6.1 below.

³⁸P-values for autocorrelations of order 1, 1-2 and 1-3 are .17, .69 and .24, respectively. We would like to point out that this has been achieved without any use of dummies to “clean” the residuals.

³⁹To see this, define the “long run” as a situation in which $\Delta \mathbf{y}_t = \mathbf{v}_t = 0$. Then clearly $\mathbf{P}_0 \mathbf{y} = \mathbf{0}$ defines a long-run relation between the variables, where the coefficients are given by \mathbf{P}_0 .

⁴⁰This is almost generically true of aggregate wage-setting schedules in bargaining models, see Bean (1994) and Manning (1993).

6.1 Empirical results

The Johansen procedure indicates that there may be 2 or 3 cointegrating vectors, i.e. $\text{rank}(\mathbf{P}_0)$ is 2 or 3, see *Table 3*. Although most tests indicate that the number is 2, and although our theoretical discussion identified 2 potential cointegrating relations, we choose 3 cointegrating vectors as our baseline case. The main reason is that we do not get any reasonable results by pursuing the analysis under the assumption of 2 cointegrating vectors, see *Section 6.1.5* below.

As we hinted at above, even though the number of cointegrating vectors is unique, the vectors themselves are not without further restrictions. To see this, note that $\alpha\beta' = \alpha\gamma^{-1}\gamma\beta' = \alpha^*\beta^{*'}$ for any non-singular $(p \times p)$ matrix γ .

Table 3: Johansen tests for the number of cointegrating vectors

$H_0 : \text{rank} = p$	$-T \log(1 - \mu)$	$T - nm$	95%	$-T / \sum T \log(\cdot)$	$T - nm$	95%
$p = 0$	66.19**	55.16**	44.0	181.4**	151.1**	114.9
$p \leq 1$	46.29**	38.57*	37.5	115.2**	95.97**	87.3
$p \leq 2$	29.41	24.51	31.5	68.87*	57.39	63.0
$p \leq 3$	22.38	18.65	25.5	39.47	32.89	42.4
$p \leq 4$	13.13	10.94	19.0	17.09	14.24	25.3
$p \leq 5$	3.956	3.296	12.3	3.956	3.296	12.3

Our preferred model assumes that we have 3 cointegrating vectors. In this case, the dimension of α is (6×3) and that of β' is (3×6) . Hence, the system may be written⁴¹

⁴¹Leaving the trend out.

$$\begin{aligned}
\begin{bmatrix} \Delta y_1 \\ \Delta y_2 \\ \Delta y_3 \\ \Delta y_4 \\ \Delta y_5 \\ \Delta y_6 \end{bmatrix}_t &= \begin{pmatrix} \alpha_{11} & \alpha_{12} & \alpha_{13} \\ \alpha_{21} & \alpha_{22} & \alpha_{23} \\ \alpha_{31} & \alpha_{32} & \alpha_{33} \\ \alpha_{41} & \alpha_{42} & \alpha_{43} \\ \alpha_{51} & \alpha_{52} & \alpha_{53} \\ \alpha_{61} & \alpha_{62} & \alpha_{63} \end{pmatrix} \times \quad (21) \\
\begin{pmatrix} \beta_{11} & \beta_{21} & \beta_{31} & \beta_{41} & \beta_{51} & \beta_{61} \\ \beta_{12} & \beta_{22} & \beta_{32} & \beta_{42} & \beta_{52} & \beta_{62} \\ \beta_{13} & \beta_{23} & \beta_{33} & \beta_{43} & \beta_{53} & \beta_{63} \end{pmatrix} &\begin{bmatrix} y_1 \\ y_2 \\ y_3 \\ y_4 \\ y_5 \\ y_6 \end{bmatrix}_{t-1} + \begin{bmatrix} \varepsilon_1 \\ \varepsilon_2 \\ \varepsilon_3 \\ \varepsilon_4 \\ \varepsilon_5 \\ \varepsilon_6 \end{bmatrix}_t
\end{aligned}$$

The elements of the β matrix are elements of the cointegrating vectors, and the elements of the α matrix can be interpreted as the speed of adjustment for a variable to deviations from equilibrium (one of the cointegrating combinations).⁴² If a row in α has only zeros, the implication is that the corresponding element of $\Delta \mathbf{y}$ is unaffected by any disequilibria (or anything that happens to the variables in the system). Then there is no loss of information from not modelling that variable, and it is weakly exogenous to the system.⁴³ This, of course, implies that it is legitimate to condition on that variable in the estimations. A variable may also be weakly exogenous with respect to one or two of the cointegrating relationships, i.e., if the corresponding α_{ij} equals zero.

Imposing three cointegrating vectors, we estimated the following system (dropping the error terms)⁴⁴:

⁴²To see this, notice that the product of the β' matrix and the \mathbf{y} vector is a (3×1) vector, the elements of which are three linear combinations of the elements of \mathbf{y} . Each row of α translates these into a Δy_i .

⁴³It is important to remember that weak exogeneity is defined relative to the system at hand.

⁴⁴The normalisation of the cointegrating vectors is arbitrary.

$$\begin{bmatrix} \Delta(w - q) \\ \Delta u \\ \Delta \gamma \\ \Delta \theta \\ \Delta(p_I - p_p) \\ \Delta \rho \end{bmatrix}_t = \begin{pmatrix} -0.459 & 0.0001 & -0.024 \\ 0.220 & -0.008 & -0.187 \\ 1.030 & 0.003 & -0.302 \\ 0.076 & -0.0001 & 0.006 \\ 0.382 & -0.001 & 0.064 \\ -0.228 & -0.007 & 0.037 \end{pmatrix} \times \quad (22)$$

$$\begin{pmatrix} 1 & 0.104 & -0.064 & -0.089 & 0.029 & 0.221 & -0.003 \\ -164.8 & 1 & -30.61 & 53.35 & 13.35 & 104.0 & -1.182 \\ -1.042 & 0.377 & 1 & 0.494 & 0.006 & -0.439 & -0.016 \end{pmatrix} \begin{bmatrix} w - q \\ u \\ \gamma \\ \theta \\ p_I - p_p \\ \rho \\ t \end{bmatrix}_{t-1}$$

The three unrestricted cointegrating combinations are plotted in *Figure 10*. The plot does not reveal too many signs of non-stationarity, although there are some small tendencies of a trend in the third one.

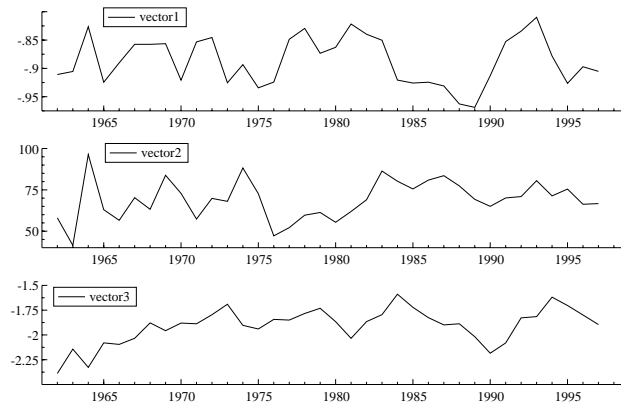

Figure 10: Unrestricted cointegrating combinations

Imposing identifying restrictions on the β vectors to find empirical counterparts to the price- and wage-setting schedules (17) and (18) and

testing for weak exogeneity by imposing zero-restrictions on α -parameters, we end up with the following system:

$$\begin{bmatrix} \Delta(w - q) \\ \Delta u \\ \Delta \gamma \\ \Delta \theta \\ \Delta(p_I - p_p) \\ \Delta \rho \end{bmatrix}_t = \begin{pmatrix} 0.141 & -0.002 & 0 \\ 0 & 0 & 0 \\ 0 & 0 & 0.270 \\ 0 & 0 & 0 \\ -0.057 & 0.002 & 0 \\ 2.344 & 0 & -0.282 \end{pmatrix} \quad (23)$$

$$\begin{pmatrix} 1 & 0.026 & -0.067 & 0 & 0 & -0.316 & 0 \\ 283.9 & 30.79 & 0 & 0 & 1 & 0 & -1.058 \\ 5.238 & 0 & -1.669 & 0 & 0 & 1 & 0 \end{pmatrix} \begin{bmatrix} w - q \\ u \\ \gamma \\ \theta \\ p_I - p_p \\ \rho \\ t \end{bmatrix}_{t-1} .$$

The p-value for the test of these restrictions is 0.35 ($\chi^2(15) = 16.48$), so the data accept the restrictions without too much protests. The restricted cointegrating combinations are plotted in *Figure 11*. Also in this case, the vectors do not seem strikingly non-stationary.

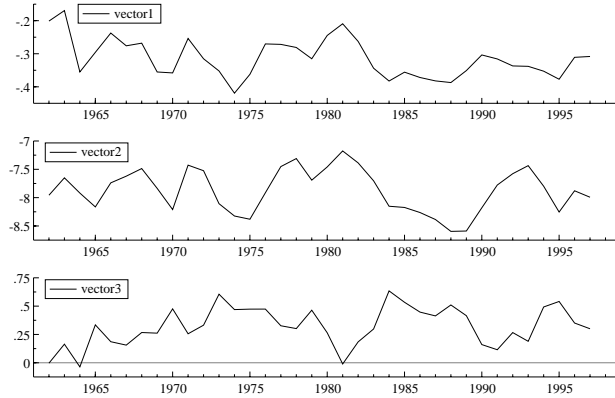

Figure 11: Restricted cointegrating combinations

We will return to an analysis of the properties of the residuals, but first we discuss the issue of identification and the substantive results of the analysis.

6.1.1 Identification

There is no doubt that the system is identified in a formal sense. The critical identifying restriction is that the time trend is present in the price-setting equation, but not in the wage-setting equation. What (if any) would the economic intuition be? Looking at the theoretical analysis, we can give a description of the condition in economic terms: what we need is something that shifts the price elasticity of demand in the product market over time without affecting the wage elasticity of labour demand. As the price elasticity of demand in the product market (η) is one of the components of the wage elasticity of labour demand (ε_N), we thus need some trend change compensating for this trend in the product market.⁴⁵ It turns out that what we need is a trend wise lower elasticity of substitution between labour and other inputs to exactly compensate the trend wise higher price elasticity of product demand. This condition definitely would be fulfilled only by sheer coincidence.⁴⁶ However, a rising elasticity of product demand would be consistent with a notion of tougher competition in the world markets, and a falling elasticity of substitution would be consistent with more specialisation and an accompanying lower substitutability among inputs. We leave it to the reader to determine how plausible this identifying restriction is.

6.1.2 The long-run equations

We begin by looking at the long-run relations produced by the cointegration analysis. The first equation is normalised so as to be interpretable as

⁴⁵The wage elasticity of demand can be decomposed into a substitution effect and an “output” effect. In our case it can be written $\varepsilon_N = \sigma(1 - \nu_N) + \eta\nu_N / (1 - \frac{d mu}{dP} \frac{P}{mu})$, where σ is the elasticity of substitution between capital and labour, ν_N the labour share of costs and mu the ratio between price and cost (the mark-up). The argument in the text follows if the price elasticity of the mark-up factor and the labour share of costs do not change “too much”.

⁴⁶At least the authors have had a hard time coming up with a mechanism with this effect.

a wage equation. If we write it out explicitly, it becomes

$$w - q = -0.026u + 0.067\gamma + 0.316\rho. \quad (24)$$

Thus, in the long run there is a negative relationship between labour’s share of value added and the unemployment rate, a positive relationship between the share and the accommodation ratio and a positive relation between the share and the replacement rate in the unemployment insurance system. The point estimate of the long-run effect of unemployment on wage setting is rather low compared to most previous estimates (see *Section 2*), which might indicate that the prolonged period of high unemployment rates in the 1990s has affected wage setting institutions adversely. The estimated positive effect of *ALMPs* is, on the other hand, rather similar to what has been found in earlier studies. The implication is that the wage-push mechanism identified in *Section 3.1.4* seems to dominate the “job-competition” effect.⁴⁷ Effects of the unemployment insurance system have been notoriously difficult to detect in studies using aggregate data. Here we find a rather strong positive relationship between wages and the replacement rate. Finally, it is worth noting that one effect is ‘conspicuous by its absence’: we test and do not reject the restriction of no long-run wage effects⁴⁸ of the wedge between the product real wage and the consumption real wage.

The second cointegrating vector has been normalised to be interpreted as a price-setting equation, where the price is the relative price between imports and production.⁴⁹ We get the following long-run equation:

$$p_I - p_p = -283.9(w - q) - 30.79u + 1.058t. \quad (25)$$

Interpreting a higher wage share, $(w - q)$, as a “cost push”, such a cost push increases the price of domestic goods in the long run.⁵⁰ A rise in unemployment, a negative “demand shock”⁵¹, increases the relative price

⁴⁷We cannot, however, rule out that the effect equals zero, see *Section 6.1.5*.

⁴⁸That is, effects on the wage costs, the implication of which is that taxes in the long run are borne by wage earners.

⁴⁹This equation directly corresponds to *equation 17* in *Section 6*.

⁵⁰Notice, however, that, according to our theoretical framework, this effect works through changes in the elasticity of product demand.

⁵¹It is actually reasonable to label it a demand shock in this model, since our tests indicate that unemployment is weakly exogenous in the system. One should, however, keep in mind that we are talking about long-run relationships.

of domestic goods. According to the price-setting rule in *Section 3.1.3*, this implies increasing returns to scale. Finally, the relative price of imports follows a rising trend. We have no good theory-based explanation to this, although, as we noted in *Section 6.1.1*, this is consistent with Swedish firms facing increasing competition in the world market. We still feel (at least somewhat) confident about the interpretation of this equation, since the data do not reject the restrictions that potential effects of taxes, unemployment insurance and labour market programmes go through their effects on wages.

The third long-run relation has been normalised to be interpreted as an equation for the replacement rate in the unemployment insurance system. Unlike in the two previous equations, we have no theory to base our interpretations on. Basically, we have derived the equation by putting as many zero-restrictions on it as possible.⁵² Written out as an equation for the replacement rate, it becomes

$$\rho = -5.238(w - q) + 1.669\gamma. \quad (26)$$

Taken at face value, the equation implies that the replacement rate in the long run is negatively related to the wage share and positively related to the accommodation ratio. One speculative interpretation of the positive long-run relationship between the accommodation rate and the replacement rate is that it reflects political preferences: generosity (or lack of it) towards the unemployed manifests itself both in high replacement rates and in ambitious *ALMPs*.

6.1.3 Exogeneity

The second upshot of the cointegration analysis is results concerning weak exogeneity. As discussed above, a row of zeros in the α matrix implies that the corresponding variable can be treated as weakly exogenous in the system. We find two such variables: the unemployment rate and the tax wedge. The latter can be understood as a statement that tax rates are determined in the political system in a way that is not systematically related to the variables in our system.

It may at first sight seem surprising that the unemployment rate turns out to be weakly exogenous. Our interpretation of the result is that it

⁵²The restrictions on the other long-run equations are primarily motivated by theoretical considerations.

may reflect the fact that we have not specified a full equilibrium model: we have neither imposed any external balance condition nor included any measure of balance of payments in the empirical analysis. The extension of the information set induced by adding new variables could turn the exogeneity result around. This means that, e.g., macroeconomic policies may influence the unemployment rate in ways that are given from the perspective of the model we have set up but not relative to a more general model.

The exogeneity result is to some extent “good news”, in the sense that, relative to the variables we analyse, we can condition on the unemployment rate, which in turn is related to the possibility to identify a wage-setting equation in the single-equation models we estimate later. On the other hand, it is not so good news from the perspective of the theoretical model presented *Section 3*.

6.1.4 Statistical properties of the system

The inference discussed above is conditional on the system possessing satisfactory statistical properties. An analysis of these properties is the subject matter of the present section, where we use the results from the cointegration analysis to formulate a short-run system for the four endogenous variables. We have thus imposed weak exogeneity of unemployment and the tax wedge. In addition to this, we have used the estimated cointegrating vectors and the other restrictions on the α matrix suggested by the cointegration analysis. Testing these restrictions in the short-run system confirms the conclusions from the cointegration analysis: the restrictions on the short-run system implied by the previous analysis are not rejected. Thus, we feel confident about conditioning on unemployment and the tax wedge.

We have, however, not attempted to model the short-run dynamics of the whole system by looking for contemporary effects of the endogenous variables. Thus, apart from the long-run relations, which we want to interpret as structural equations corresponding (in the case of the price- and wage-setting equations) to equations in our theoretical modelling, we do not want to give any structural interpretation of our short-run equations. We mainly estimate them to show that the resulting system possesses satisfactory statistical properties.

The statistical properties, as measured by tests for residual autocor-

relation, normality and heteroscedasticity reveal problems with normality for the system as a whole, and looking at single equations, the problems arise in the equation for the relative price. System tests do not indicate problems with either autocorrelation or heteroscedasticity, although there is significant heteroscedasticity in the equation for the replacement rate. More information on the estimated system and some of the diagnostic tests are reproduced in *Appendix B*. The actual and fitted values and scaled residuals are reproduced in *Figure 12*.

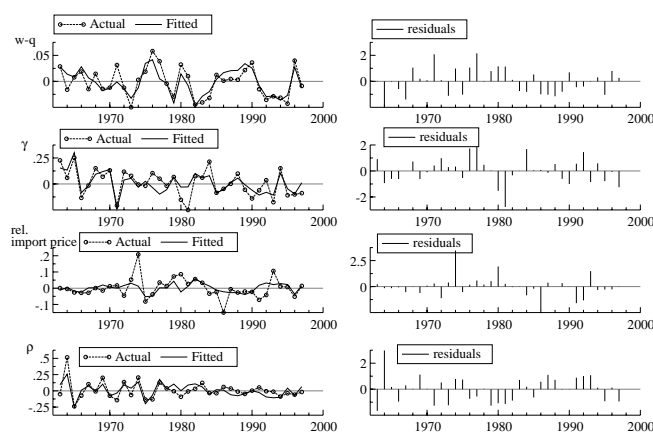

Figure 12: Actual and fitted values and scaled residuals in the dynamic system

6.1.5 Sensitivity analysis

How robust are the results presented above? We have performed some “sensitivity analysis”, where we try a number of alternative sets of identifying restrictions. A first set of tests pertain to the third cointegrating relation, where we look for a cointegrating relation with some natural interpretation. More specifically, we look for a third cointegrating relation that can be interpreted as a “budget constraint”. Thus, we look for a possible negative relationship between the generosity of the unemployment insurance system and the volume of *ALMPs*, and we want this trade-off to be shifted downwards (upwards) by a decreasing (increasing) tax base. We also analyse the possible different wage- and price-setting

relations that pass tests, given the third cointegrating relation presented in the baseline case above. Our second set of tests assumes that we instead of three cointegrating vectors have two. Under this assumption we examine whether our estimated long-run wage-setting relation changes substantially or is mainly unchanged. In both sets of tests, we restrict the analysis to restrictions that pass tests and where the first two relations have clear interpretations as wage- and price-setting relations.

Three cointegrating vectors The set-up in the analysis where we assume that there are three cointegrating vectors is that we impose the same restrictions on the α -matrix as in the baseline case above. Furthermore, we let the third cointegrating vector be rather “freely” estimated—we only restrict the analysis to relations where the relative price is excluded. Briefly, the results are negative with respect to the third cointegrating relation. We never end up with cointegrating vectors that can be interpreted as budget constraints, and the resulting “cointegrating” combinations generally look “more” non-stationary than the unrestricted combination plotted in *Figure 10*. Fixing the third cointegrating relation and concentrating on wage- and price-setting relations, we find four different sets of restrictions that pass tests (including the baseline case above). In these cases, the coefficient on programme participation either is in the same magnitude as in the baseline case above or zero. Thus, we find a weak wage-pushing effect of programmes, but we cannot rule out that there is no effect at all.

Two cointegrating vectors Looking at systems under the assumption of two cointegrating vectors leaves us with three possible systems that pass all tests. They are fairly similar, and are all characterised by what we find unreasonable point estimates. In particular, we find an extremely strong upward push on wages from the replacement rate in the *UI* system, and a similarly extremely strong wage moderation from *ALMPs*.⁵³ We find these effects too extreme to be taken seriously, and stick to the case with three cointegrating vectors as our preferred one.

⁵³The point estimates are around -0.3 for programmes and above 1.0 for the replacement rate.

6.2 Concluding comments on the estimated systems

Our main finding related to wage setting and *ALMPs* is that there may be a small wage-raising effect of *ALMPs*, but we cannot strongly rule out that the effect equals zero. Furthermore, we have found a long-run effect of unemployment on wages that is somewhat lower than most previous estimates. The result that the tax wedge does not matter for wage pressure in the long run is somewhat at odds with most previous studies, as is the estimated fairly strong long-run positive covariation between real wages and the replacement rate in the *UI* system.

We have also found that both the unemployment rate and the tax wedge between the product real wage and the consumption real wage are weakly exogenous with respect to the variables that we have analysed. The former finding, which seems fairly robust, implies that we can in fact identify a structural wage-setting relation in the data.⁵⁴

On the other hand, some of the estimated effects are non-robust to changes in specifications, and we end up with a preferred system where we can only give some theory-based interpretation of two of the three identified cointegrating vectors.

7 Single equations modelling

7.1 Introduction

The main drawback with systems modelling, as discussed above, is that the limited number of observations severely constrains the number of variables that can enter the analysis. Our strategy in this section is to look closer at the wage-setting relation in a single-equation context, making use of the results from the systems analysis. The analysis in this section will naturally also draw on the theoretical analysis, where some variables that were not modelled in the systems context were discussed. Finally, we will also relate our analysis to earlier attempts to model aggregate Swedish wage setting with a focus on the role of *ALMPs*.

Starting with the theoretical analysis, the upshot of *equation* (12) in log-linearised form is a wage-setting relation of the following form (letting

⁵⁴That is, we can trace the effects of changes in unemployment on wage setting without modelling the unemployment rate. See the discussion in Bean (1994).

lower-case letters represent natural logarithms):

$$w - p_p = a_0 + a_1q - a_2u + a_3\gamma + a_4\theta + a_5(p_I - p_p) + a_6rip + a_7\rho, \quad (27)$$

where $w - p_p$ is the product real wage rate, q productivity, u the unemployment rate, γ the accommodation ratio, θ the tax wedge, $(p_I - p_p)$ the relative price of imports, rip the measure of residual income progressivity and ρ the replacement rate in the unemployment insurance system. We expect all parameters except a_1 and a_3 (which can be either positive or negative) to be non-negative.

Our primary interest in *equation* (27) is in looking at the effect of *ALMPs* on wage setting. Thus, we will especially focus on the estimate of a_3 . We will both compare this estimate to effects found in earlier studies and look at the evolution of the parameter over time to determine whether our finding in the systems analysis of a rather small effect reflects changing labour market conditions and/or the new policy mix in the 1990s or if it primarily is driven by differences in model specification or by new data series.

A number of special cases of *equation* (27) can be found, either from theory by imposing restrictions on technology or union objectives, or by looking at “stylised facts” or empirical findings in earlier studies. In addition, a number of policy questions are related to some of these restrictions. Some of these issues will be brought up in the presentation of the results.

7.2 Empirical specification of dynamic baseline model

Following the analysis in previous sections, we treat the variables in *equation* (27) as potentially first-order integrated. Thus, we must formulate the econometric model in such a way that non-stationary variables are transformed into stationary ones. This can be achieved either by taking first-differences of potentially $I(1)$ variables or by forming stationary (i.e. cointegrating) combinations of them. Taking first differences destroys valuable long-run information. Hence, our strategy is to find stationary linear combinations of the variables.

This can, in turn, either be achieved by the two-step Engle and Granger (1987) procedure or by a one-step procedure, where the lagged potentially cointegrated variables are entered as single explanatory variables in a regression with the dependent variable in first-difference form.

As there is some evidence that the small-sample properties of the one-step approach are better (Banerjee, Dolado, Galbraith, and Hendry, 1993), we follow this approach.⁵⁵ The baseline transformation we use is the following⁵⁶:

$$\begin{aligned} \Delta(w - p_p)_t = & b_0 + b_1(w - p_p)_{t-1} + b_2q_{t-1} + b_3u_{t-1} + b_4\gamma_{t-1} \quad (28) \\ & + b_5\theta_{t-1} + b_6(p_I - p_p)_{t-1} - b_7rip_{t-1} + b_8\rho_{t-1} + \\ & b_9\Delta q_t + b_{10}\Delta u_t + b_{11}\Delta\gamma_t + b_{12}\Delta\theta_t + b_{13}\Delta(p_I - p_p)_t \\ & - b_{14}\Delta rip_t + b_{15}\Delta\rho_t + b_{16}\Delta(w - p_p)_{t-1} + \varepsilon_t. \end{aligned}$$

This model was estimated by *OLS* and *IV* methods, and in both cases passed diagnostic tests.⁵⁷ Plots of recursive parameter estimates did not indicate any substantial problems of parameter instability. Given these results, we take the estimates of *equation* (28) as our benchmark for further testing.

7.3 Results

We start by testing whether the product real wage is unit elastic with respect to productivity in the long run. This is equivalent to testing the restriction $b_1 = -b_2$.⁵⁸ This test is passed in both the *IV* and *OLS*

⁵⁵The critical values for the significance tests for the lagged levels variables are not given by the t-distribution; the Dickey-Fuller distribution should be used instead, see Kremers, Ericsson, and Dolado (1992).

⁵⁶We have tested and not rejected nominal homogeneity both in the short and in the long run by using the change in the nominal wage cost as the left-hand side variable and the producer price on the right-hand side. Thus, we start in a real model.

⁵⁷The instruments used in the *IV* estimation were the logged world market oil price in t and $t - 1$; the long-run US real interest rate in t and $t - 1$; Δq_{t-1} , Δu_{t-1} ; $\Delta\gamma_{t-1}$, $\Delta\theta_{t-1}$; Δrip_{t-1} ; $\Delta(p_I - p)_{t-1}$ and $\Delta\rho_{t-1}$. Δq_t , $\Delta\gamma_t$, Δrip_t and $\Delta(p_I - p)_t$ were treated as endogenous, given the results of the exogeneity tests in the systems analysis. The diagnostic tests used were tests for first- and second-order autocorrelation in the residuals (*AR*(1-2)), *ARCH*(1), residual normality and a *RESET* test for heteroskedasticity. The Sargan test for instrument validity was passed at the 10% level.

⁵⁸It is often considered to be a stylised fact that wage costs in the long run are unit elastic with respect to labour productivity. If that is the case, the wage share and employment will be independent of productivity developments in the long run. This is, however, a property of the equilibrium of the whole system and not only of the wage-setting schedule. Nevertheless, we will test the restriction that also the wage-setting schedule is unit elastic with respect to labour productivity. It is hard to find good theoretical reasons for this restriction, but we feel the fact that it has been tested

models.⁵⁹ A further test for unit elasticity also in the short run ($b_9 = 1$) was passed as well. However, the hypothesis that neither taxes nor relative prices matter for wage costs in the long run ($b_5 = b_6 = 0$) in addition to the restrictions on the effects of productivity was forcefully rejected.⁶⁰

Imposing the non-rejected restrictions, we can rewrite the model as

$$\begin{aligned} \Delta(w - q)_t = & b_0 + b_1(w - q)_{t-1} + b_3u_{t-1} + b_4\gamma_{t-1} & (29) \\ & + b_5\theta_{t-1} + b_6(p_I - p_p)_{t-1} - b_7rip_{t-1} + b_8\rho_{t-1} + \\ & b_{10}\Delta u_t + b_{11}\Delta\gamma_t + b_{12}\Delta\theta_t + b_{13}\Delta(p_I - p_p)_t \\ & - b_{14}\Delta rip_t + b_{15}\Delta\rho_t + b_{16}\Delta(w - q)_{t-1} + \varepsilon_t \end{aligned}$$

The results of estimating *equation* (29) by *OLS* and *IV* methods are reproduced in *Tables* 4 and 5.

As the model at this stage is over-parameterised, we defer the discussion of point estimates to the parsimoniously parameterised model that results from imposing zero-restrictions on the model above. It is, however, worth noting that the long-run wage-setting relation that can be derived from the estimates in *Table* 4 or 5 looks rather different than the relation derived from the systems modelling.⁶¹

Sequentially dropping the least significant variables, we get the parsimonious model in *Table* 6.⁶² The restrictions are not rejected by an F-test (the p-value is 0.84). Judging from the specification tests reported in the table, there are no clear signs of mis-specification either. Looking instead at the graphical output in *Figures* 13 and 14, we first note that the fit is fairly good, but that the equation has some problems to trace the developments in the late 1980s and early 1990s. More interestingly, however, the plots of the recursively estimated parameters show very small signs of changing parameters in the 1990s, with the exception of the estimated effect of the income-tax progressivity factor. There is a slight upward

without rejection in a number of earlier studies (for example Rødseth and Nymoen (1999) and Forslund (1995)) is a good enough reason. This restriction was also imposed rather than tested in our systems analysis.

⁵⁹The test used was a Wald test. The p-values were 0.37 (*IV*) and 0.22 (*OLS*).

⁶⁰ $\chi^2(4) = 34.843[0.0000]**$ in the *OLS* model and $\chi^2(4) = 25.714[0.0000]**$ in the *IV* model.

⁶¹The estimated effects of *ALMPs* and the replacement rate are, for example, both smaller and statistically insignificant in the *IV* estimation. The sign of the estimated effect of the replacement rate is even negative.

⁶²*OLS* results, presented for the sake of comparison, are given in *Table* 7.

Table 4: *OLS* estimates

Variable	Coefficient	Std.Error	t-value
Constant	-0.674	0.085	-7.972
$(w - q)_{t-1}$	-0.908	0.122	-7.453
u_{t-1}	-0.043	0.008	-5.570
γ_{t-1}	-0.006	0.025	-0.234
θ_{t-1}	0.175	0.038	4.557
$(p_I - p_p)_{t-1}$	-0.014	0.035	-0.403
rip_{t-1}	-0.101	0.043	-2.351
ρ_{t-1}	-0.016	0.047	-0.337
Δu_t	0.071	0.020	3.623
$\Delta \gamma_t$	0.031	0.033	0.929
$\Delta \theta_t$	0.512	0.107	4.809
$\Delta(p_I - p_p)_t$	0.156	0.059	2.647
Δrip_t	-0.067	0.035	-1.886
$\Delta \rho_t$	-0.028	0.028	-0.989
$\Delta(w - p_p)_{t-1}$	0.395	0.146	2.702
$R^2 = 0.886$	$F(14,21) = 11.66$ [0.000]	$\sigma = 0.012$	DW = 2.20
Information Criteria	SC = -7.85	HQ = -8.281	FPE=0.0002
AIC = -8.511			
AR 1-2 $F(2, 19) = 0.310$ [0.737]		ARCH 1 $F(1, 19) = 0.252$ [0.622]	
Normality $\chi^2(2) = 1.914$ [0.384]		RESET $F(1, 20) = 1.346$ [0.260]	

drift in the estimated effect of unemployment, but the confidence interval is shrinking, implying that the parameter becomes more precisely estimated.⁶³

7.3.1 The point estimates

We now proceed by looking at the implications of the *IV* point estimates. First, we derive the *long-run equation* corresponding to the model in *Table 6*. This is achieved by setting all variables $x_t = x_{t-1} = x$. Doing this, we get

$$(w - q) = -0.716 + 0.162\theta - 0.076rip - 0.051u. \quad (30)$$

⁶³As *ALMPs* are not included in the parsimonious model, there are no recursive parameter estimates plotted for this variable. Looking instead at recursive estimates of the parameters of the full model, the effect of *ALMPs* is estimated to be close to zero in all sub-samples from 1988 onwards. It is also very imprecisely estimated. Thus, there are no signs of a significant change in this (non-)effect.

Table 5: *IV* estimates

Variable	Coefficient	Std.Error	t-value
$\Delta(p_I - p_p)_t$	0.289	0.104	2.773
$\Delta\rho_t$	-0.010	0.054	-0.179
Δrip_t	-0.021	0.081	-0.256
$\Delta\gamma_t$	0.067	0.046	1.463
γ_{t-1}	0.003	0.039	0.082
$(w - q)_{t-1}$	-1.054	0.176	-5.986
θ_{t-1}	0.190	0.044	4.297
$\Delta\theta_t$	0.632	0.143	4.406
$(p_I - p_p)_{t-1}$	0.023	0.046	0.486
Constant	-0.758	0.113	-6.715
rip_{t-1}	-0.066	0.075	-0.874
u_{t-1}	-0.052	0.011	-4.666
ρ_{t-1}	-0.0003	0.082	-0.003
Δu_t	0.092	0.027	3.378
$\Delta(w - p_p)_{t-1}$	0.580	0.199	2.906
Additional Instruments used:		$\Delta\theta_{t-1}$	$\Delta\gamma_{t-1}$
US interest rate in t and $t - 1$		oil price in t and $t - 1$	
Δu_{t-1}			
$\sigma = 0.014$	DW = 2.29	Reduced Form $\sigma = 0.013$	
Specification $\chi^2(4) = 3.237$ [0.519]		Testing $\beta = 0 : \chi^2(14) = 127.68$ [0.000]**	
AR 1- 2 F(2, 19) = 0.821 [0.455]		ARCH 1 F(1, 19) = 0.844 [0.370]	
Normality $\chi^2(2) = 1.408$ [0.495]			

All parameters (except, perhaps, the estimated effect of tax progressivity) are significantly different from zero at conventional levels.⁶⁴ A number of interesting observations can be made.

1. We see that there is no long-run effect of *ALMPs* on real-wage pressure. This is in some contrast to the previous systems results, although we could not preclude that the coefficient also in that case equals zero. It is also in some contrast to most earlier studies on aggregate data (see the summary in *Section 2*). There is, however, a certain difference between the specification in the present study and many earlier ones: most previous studies have used the accommodation ratio and the sum of open unemployment and programme participation as regressors, thus holding the sum of unemployment and

⁶⁴The test statistics are not distributed according to the t-distribution, because the variables, according to our previous tests, are first-order integrated. See footnote 55.

Table 6: *IV* estimates of parsimonious model

Variable	Coefficient	Std.Error	t-value
$\Delta(p_I - p_p)_t$	0.200	0.057	3.499
$(w - q)_{t-1}$	-0.918	0.104	-8.832
θ_{t-1}	0.149	0.025	5.980
$\Delta\theta_t$	0.522	0.091	5.713
Constant	-0.657	0.067	-9.736
rip_{t-1}	-0.070	0.030	-2.298
u_{t-1}	-0.047	0.007	-6.709
Δu_t	0.061	0.013	4.755
$\Delta(w - p_p)_{t-1}$	0.434	0.114	3.816
Additional Instruments used:		$\Delta\theta_{t-1}$	$\Delta\gamma_{t-1}$
US interest rate in t and $t - 1$		oil price in t and $t - 1$	
Δu_{t-1}			
$\sigma = 0.013$	DW = 2.43	Reduced Form $\sigma = 0.014$	
Specification $\chi^2(6) = 5.600$ [0.469]		Testing $\beta = 0 : \chi^2(8) = 138$ [0.000]**	
AR 1- 2 F(2, 19) = 1.322 [0.285]		ARCH 1 F(1, 19) = 1.5243e-006 [0.999]	
Normality $\chi^2(2) = 0.156$ [0.925]			

Table 7: *OLS* estimates of parsimonious model

Variable	Coefficient	Std.Error	t-value
$\Delta(p_I - p_p)_t$	0.163	0.044	3.742
$(w - q)_{t-1}$	-0.882	0.096	-9.144
θ_{t-1}	0.141	0.023	6.076
$\Delta\theta_t$	0.496	0.087	5.724
Constant	-0.630	0.061	-10.258
rip_{t-1}	-0.068	0.030	-2.280
u_{t-1}	-0.046	0.007	-6.727
Δu_t	0.058	0.012	4.707
$\Delta(w - p_p)_{t-1}$	0.404	0.108	3.726
$\sigma = 0.013$	DW = 2.36	$R^2 = 0.841$	
F(8,27)=17.901 [0,0000]			
AR 1- 2 F(2, 25) = 1.179 [0.324]		ARCH 1 F(1, 25) = 0.079 [0.781]	
Normality $\chi^2(2) = 0.171$ [0.918]			

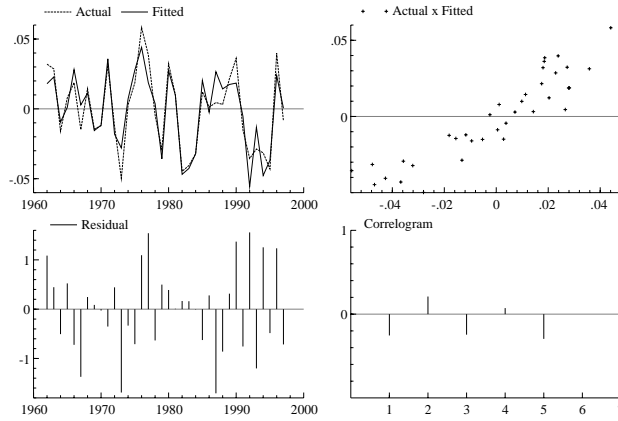

Figure 13: Actual and fitted values, scaled residuals, cross plot of actual and fitted values, scaled residuals and residual correlogram

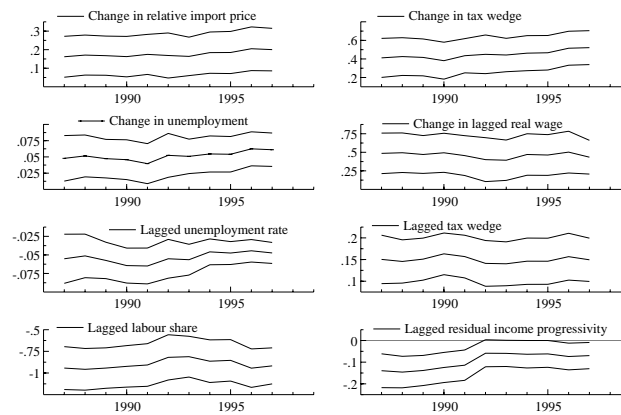

Figure 14: Recursive parameter estimates

programme participation constant. The implied experiment in those studies hence is a transfer from unemployment to programmes. Instead, holding open unemployment constant as in the present study, the assumption is that the transfer is performed leaving unemploy-

ment unaffected. The finding could, of course, also reflect that the change in programme mix and the dramatically different labour market situation in the 1990s make a difference regarding the effects of *ALMPs* on wages. However, the results of our recursive estimations contradict this interpretation.

2. There is no significant long-run effect of the replacement rate on wage pressure. This is much in line with most previous studies, although very much at odds with the results in our systems modelling.
3. There is a significant effect of the tax wedge. According to the point estimate, just above 15% of a rise in the tax wedge contributes to a long-run wage pressure.
4. The progressivity of the tax system has a long-run effect contrary to the expected direction. A 10% fall in the coefficient of residual income progressivity raises wage pressure by approximately 0.75%.
5. Finally, there is a significant long-run effect of unemployment on wage pressure. According to the point estimate, a reduction in unemployment from 8% to 6% (i.e., by 25%) is in the long run associated with slightly less than 1.5% higher wage pressure. This effect, although larger than the one we found in the systems estimations, is in the lower end of the interval spanned by parameters found in previous studies. Thus, it cannot be ruled out that the higher unemployment rate in the 1990s has affected the Swedish wage setting mechanism. This interpretation is, however, to some extent contradicted by the finding in the recursive estimations, where it is hard to see signs of any substantial changes in the estimated parameters.

With respect to the *short-run dynamics*, we find the following:

1. Rises in both the tax wedge and the relative import price contribute significantly to an increased wage pressure in the short run. The estimated elasticities are 0.50 and 0.16, respectively. The point estimate of the effect of the tax wedge implies that the burden of higher taxes in the short run is shared fairly equally between workers (in the form of reduced consumer real wages) and firms (in the form of higher real product wages). This is broadly consistent with earlier findings.

2. The estimated effect of the change in unemployment is positive. This is somewhat surprising. If the long-term unemployed exert a lower downward wage pressure than the short-term unemployed, we would expect the opposite sign. The same conclusion would follow from an insider-outsider framework. The sign is also opposite the one found by Forslund (1995).
3. Finally, the positive sign of the effect of the lagged change in the product real wage rate probably picks up some inertia in the wage-setting process that we have not modelled, and which manifests itself as positive serial correlation.

7.3.2 Alternative specifications of the labour market variables

To facilitate comparisons with earlier studies and to check the robustness of our results, we now look at two alternative specifications of the “labour market variables” (the measures of unemployment and programme participation).

First, as discussed on page 37, most previous studies have used the sum of open unemployment and programme participation (“total unemployment”) as the measure of the labour market situation. Thus, we also estimate equations based on the following specification of the wage-setting relation:

$$w - p_p = a_0^1 + a_1^1 q - a_2^1 ut + a_3 \gamma + a_4^1 \theta + a_5^1 (p_I - p_p) + a_6^1 rip + a_7^1 \rho, \quad (31)$$

where ut is the (logged) sum of the open unemployment rate and the programme participation rate. With this specification, a positive coefficient on the accommodation rate (γ) means that the experiment of taking people out of open unemployment and into programmes, given “total unemployment”, exerts an upward pressure on wages.

Second, Rødseth and Nymoen (1999) use the total unemployment rate ut and a measure of programme participation which can be written $\gamma a \equiv \log(1 - \Gamma)$, where $\Gamma \equiv R/(R + U)$; R is the fraction of the labour force in programmes and U is the unemployment rate. This gives rise to the following specification:

$$w - p_p = a_0^2 + a_1 q - a_2^2 ut + a_3^2 \gamma a + a_4^2 \theta + a_5^2 (p_I - p_p) + a_6^2 rip + a_7^2 \rho. \quad (32)$$

With this formulation, it is straightforward to test whether only total unemployment matters (in which case we have $a_3^2 = 0$) or if only open unemployment matters (in which case we have $a_2^2 = a_3^2$).⁶⁵

Also in this case we derive parsimonious models by sequentially eliminating variables, which, according to tests, are statistically non-significant.

We begin by looking at the *IV* estimates of the model with “total unemployment” and the accommodation rate, which are displayed in *Table 8*.

Table 8: *IV* estimates of parsimonious model with “total unemployment” and accommodation ratio

Variable	Coefficient	Std.Error	t-value
$\Delta(p_I - p_p)_t$	0.285	0.083	3.438
θ_{t-1}	0.202	0.044	4.539
Constant	-0.690	0.103	-6.684
$\Delta\theta_t$	0.708	0.134	5.285
$(w - q)_{t-1}$	-0.914	0.124	-7.383
ut_{t-1}	-0.064	0.010	-6.708
$\Delta(w - p_p)_{t-1}$	0.494	0.140	3.521
Δut_t	0.068	0.019	3.596
γ_{t-1}	0.021	0.016	1.291
Additional Instruments used:		$\Delta\theta_{t-1}$	$\Delta\gamma_{t-1}$
US interest rate in t and $t - 1$		log oil price in t and $t - 1$	
Δut_{t-1}			
$\sigma = 0.015$	DW = 1.68	Reduced Form $\sigma = 0.015$	
Specification $\chi^2(6) = 6.408$ [0.379]	Testing $\beta = 0 : \chi^2(8) = 92.13$ [0.000]**		
AR 1- 2 F(2, 25) = 0.455 [0.640]	ARCH 1 F(1, 25) = 0.040 [0.843]		
Normality $\chi^2(2) = 2.324$ [0.313]			

Looking at the t-statistic, the effect of the accommodation rate seems insignificant. The point estimate is, furthermore, close to zero. Thus, the effect would in any case be small. Performing F-tests and using the Schwarz criterion, deletion of the accommodation rate from the equation is, however, rejected.⁶⁶ Extracting the long-run equation corresponding

⁶⁵To see the second property, notice that the partial derivative of the wage share with respect to the programme participation rate equals $(a_2^2 + a_3^2)/(u + r)$. Thus, the partial effect of programme participation equals zero in the case referred to in the text.

⁶⁶Notice, however, that critical values should not be taken from the usual distributions, see footnote on *page 51*.

to the short-run model in *Table 8*, we get the following:

$$(w - q) = -0.755 + 0.221\theta - 0.075ut + 0.023\gamma \quad (33)$$

Comparing the results regarding the effect of *ALMPs* with the estimates in Calmfors and Forslund (1990), the elasticity found in the present study (0.023) is significantly lower than the average long-run elasticity (0.20) found by Calmfors and Forslund (*Table 7*, pp. 102–03). We will return to the issue of what accounts for the difference in results; for now it suffices to point out that recursive parameter estimates do not indicate any significant parameter change occurring after 1986, the stop year of the analysis in Calmfors and Forslund (1990).

Comparing the other point estimates to the long-run estimates in our baseline model (*equation (30)*), we see that the coefficient of residual income progressivity now is found insignificant, that the point estimate of the effect of the tax wedge is slightly higher in the present model and that the long-run effect of “total unemployment” (perhaps surprisingly) is estimated to be somewhat stronger than the estimated effect of open unemployment in *equation (30)*.

Next, in *Table 9*, we look at the specification of the labour market variables introduced by Rødseth and Nymoén (1999). With this formulation, we are first interested in whether the coefficient on the programme variable equals zero. In case it does, open unemployment and programme participation have the same effect on wage pressure, and only “total unemployment” matters. Second, in case the coefficient on “total unemployment” equals the negative of the coefficient on the programme variable, the partial effect of programmes equals zero and only open unemployment matters (see *footnote 65*).

A somewhat disturbing feature of the estimates in *Table 9* is that the point estimate of the effect of the lagged dependent variable exceeds unity, although it cannot be ruled out that the coefficient equals one, in which case the equation effectively becomes a Phillips curve.

Once again, we find that the accommodation rate is insignificant according to the *t*-test but also that an *F*-test and the Schwarz criterion reject deleting the variable from the equation (but note the caveat on testing in the presence of non-stationary variables discussed on *page 51*). The size of the point estimate also indicates a numerically small effect.⁶⁷

⁶⁷Raising the accommodation rate from 30 per cent to 50 per cent at a given level of “total unemployment” would raise the wage pressure by about 1.5 per cent.

Table 9: *IV* estimates of parsimonious model with “total unemployment” and $\log(1 - \Gamma)$

Variable	Coefficient	Std.Error	t-value
$\Delta(p_I - p_p)_t$	0.274	0.077	3.542
Δut_t	0.082	0.018	4.619
θ_{t-1}	0.196	0.043	4.584
rip_{t-1}	-0.069	0.032	-2.129
γa_{t-1}	-0.047	0.028	-1.666
Constant	-0.765	0.093	-8.236
$\Delta\theta_t$	0.645	0.120	5.365
$w - q_{t-1}$	-1.044	0.131	-7.945
ut_{t-1}	-0.055	0.009	-6.178
$\Delta(w - p_p)_{t-1}$	0.523	0.125	4.177
Additional Instruments used:		$\Delta\theta_{t-1}$	$\Delta\gamma a_{t-1}$
US interest rate in t and $t - 1$		oil price in t and $t - 1$	
Δut_{t-1}			
$\sigma = 0.014$	DW = 2.22	Reduced Form $\sigma = 0.014$	
Specification $\chi^2(6) = 4.331$ [0.632]	Testing $\beta = 0 : \chi^2(9) = 127.21$ [0.000]**		
AR 1- 2 F(2, 24) = 0.396 [0.678]	ARCH 1 F(1, 24) = 1.059 [0.314]		
Normality $\chi^2(2) = 1.253$ [0.534]			

Thus, we find no evidence for strong *ALMP* effects on wage pressure.

Testing whether the coefficients on “total unemployment” and the accommodation rate add up to zero produces a forceful rejection (the p -value equals 0.0002). Combined with the significant effect of total unemployment, we conclude that total unemployment rather than only open unemployment contributes to wage moderation.

Comparing the results to those in the previous model, we find that the coefficient of residual income progressivity has a significant effect in the present model as opposed to in the model with total unemployment and the accommodation rate. As in the baseline model, this effect has the “wrong” sign.

As the long-run solution is not well defined, it is obvious that we cannot discuss any such results within the framework of the present model.

Finally, once again recursive estimates fail to indicate any serious parameter instability occurring during the 1990s.⁶⁸

⁶⁸With the exception of the estimated effect of income tax progressivity, which behaves in the same way as in the baseline model; the estimated effect of the lagged wage

Encompassing Although we have an *a priori* preference for the formulation in our baseline model, it is appropriate to check which model the data prefers. This can be done formally by applying encompassing tests, which test whether a chosen model can account for results produced by other models. Encompassing tests are implemented in PcGive (see Hendry and Doornik (1996) for the details and Hendry (1995), ch. 14, for a more general discussion).

We cannot test the baseline model (M1) against the second alternative model (M3) because the test would involve variables that are perfectly collinear. We can, however, compare the estimated standard errors of the models, and doing so we find that the estimated standard error for M1 is lower than for M3.⁶⁹

Furthermore, we cannot reject that M1 encompasses the first alternative specification (M2), whereas the opposite is rejected.

Comparing M2 and M3, we reject that the former encompasses the latter, whereas it cannot be rejected that M3 encompasses M2.

We conclude that there is no compelling reason in terms of encompassing to abandon our baseline model in favour of any of the alternatives.

7.4 Static modelling—canonical cointegrating regressions

A problem that is common to both the Johansen procedure and the dynamic single-equations modelling is that inference under both methods relies on correctly specified dynamics. To the extent that we are interested in both short-run and long-run relationships, it goes without saying that we have to model both. However, if the main interest lies in finding long-run relationships, the short run is modelled mainly to yield correct inference about the long run. In this perspective, an incorrect modelling of short-run dynamics may introduce bias and dependence on “nuisance parameters” into the long-run relationships of interest. Park (1992) develops a procedure, *canonical cointegrating regressions (CCR)*, which involves *OLS* regressions on transformed data. These regressions yield asymptotically efficient estimators as well as valid inference on cointegrating (long-run) relationships. The data transformations involve only stationary (short-run) components of a given model.

share is also somewhat unstable.

⁶⁹This is a necessary but not sufficient condition for encompassing in linear regression models, see Hendry (1995), ch. 14.

As the method is not so well known, we begin by presenting some of the main ideas of the approach. Then we present our estimation results. To fix ideas and introduce the notation of Park (1992), we look at the time series $\{x_t\}$ and $\{y_t\}$, generated by

$$y_t = \pi_1' c_t + y_t^0 \quad (34)$$

$$x_t = \Pi_2' c_t + x_t^0, \quad (35)$$

where c_t is a k -dimensional deterministic sequence and $\{y_t^0\}$ and $\{x_t^0\}$ are general 1 and m -dimensional $I(1)$ processes. Denote the $m+1$ -dimensional stochastic sequence that drives y_t and x_t by $\{w_t\}$ and construct

$$B_n(t) = \frac{1}{\sqrt{n}} \sum_{i=1}^{[nt]} w_i. \quad (36)$$

Under general conditions, B_n converges weakly to a vector Brownian motion B as $n \rightarrow \infty$. Denote the covariance matrix of the limit Brownian motion by Ω , the *long run variance* of $\{w_t\}$.

Partition B and Ω as

$$B = (B_1, B_2)' \quad (37)$$

and

$$\Omega = \begin{pmatrix} \omega_{11} & \omega_{12} \\ \omega_{21} & \Omega_{22} \end{pmatrix} \begin{pmatrix} 1 \\ m \end{pmatrix} = \begin{pmatrix} \omega_{11} + \omega_{12}m \\ \omega_{21} + \Omega_{22}m \end{pmatrix} \quad (38)$$

Let $\Psi(i) = E(w_t w_{t-i}')$ be the covariance function of $\{w_t\}$. Then the long run variance of w_t is given by $\Omega = \sum_{-\infty}^{+\infty} \Psi(i)$. Furthermore, Ω may be decomposed as $\Omega = \Sigma + \Lambda + \Lambda'$, where

$$\Sigma = \Psi(0) \quad \text{and} \quad \Lambda = \sum_{i=1}^{\infty} \Psi(i). \quad (39)$$

We also define

$$\Gamma \equiv \Sigma + \Lambda \quad (40)$$

$$= \Psi(0) + \sum_{i=1}^{\infty} \Psi(i) \quad (41)$$

and partition these parameters as in Ω in (38) and let

$$\Gamma_2 = (\gamma'_{12}, \Gamma'_{22})'. \quad (42)$$

Assume that $\{y_t^0\}$ and $\{x_t^0\}$ are cointegrated. Then

$$y_t^0 = \alpha' x_t^0 + u_t, \quad (43)$$

where u_t is stationary. Set

$$p_t = (u_t, \Delta x_t^{0'})'. \quad (44)$$

We look at the following regression model:

$$y_t = \alpha' x_t + e_t, \quad (45)$$

and let $\{e_t\} = \{u_t\}$ in the regression above and let

$$w_t = (e_t, \Delta x_t^{0'})'. \quad (46)$$

In general, the *OLS* estimator of α is at least \sqrt{n} -consistent. Its limiting distribution is, however, in general non-Gaussian and biased; standard tests have nonstandard asymptotic distributions and depend on nuisance parameters.

Now consider the following transformations (*CCR*):

$$x_t^* = x_t - (\Sigma^{-1}\Gamma_2)' w_t \quad (47)$$

$$y_t^* = y_t - (\Sigma^{-1}\Gamma_2\alpha + (0, \omega_{12}\Omega_{22}^{-1})')' w_t. \quad (48)$$

A key result in Park (1992) is that these transformations asymptotically eliminate endogeneity bias caused by long-run correlation of innovations of the stochastic regressors and regression errors as well as bias from cross correlations between stochastic regressors and regression errors. This, furthermore, means that the asymptotic theory of tests based on *CCR* is the same as for classical regression.

The transformations in *equations* (47) and (48) involve a number of unknown entities (parameters such as α, Γ, Σ and Ω and the processes $\{\Delta x_t\}$ and $\{e_t\}$). These must be estimated. Set

$$\hat{w}_t = (\hat{e}_t, \Delta x_t^{0'})'. \quad (49)$$

The $\{\hat{\epsilon}_t\}$ and $\hat{\alpha}$ can be obtained from the regression (45) and the $\{\Delta x_t^0\}$ can be obtained from an estimation of *equation* (35):

$$x_t = \hat{\Pi}'_2 c_t + \hat{x}_t^0, \quad (50)$$

or directly from a regression of $\{\Delta x_t\}$ on $\{\Delta c_t\}$. Given $\{\hat{w}_t\}$, its variance Σ can be estimated consistently by

$$\hat{\Sigma} = \frac{1}{n} \sum_{t=1}^n \hat{w}_t \hat{w}_t'. \quad (51)$$

Consistent estimates of Ω and Γ can be obtained by standard spectrum estimates. For our estimations, we rely on a kernel estimator implemented in Gauss code written by Masao Ogaki.⁷⁰

7.4.1 Results

Once again, the starting point for the empirical analysis is the static model in *equation* (27), which we for convenience reproduce below:

$$w - p_p = a_0 + a_1 q - a_2 u + a_3 \gamma + a_4 \theta + a_5 (p_I - p_p) + a_6 r i p + a_7 \rho. \quad (52)$$

As a main point of applying *CCR* is that we do not have to specify the dynamics, *equation* (52) is the model we estimate. The results are displayed in *Table* 10.

The estimates without any restrictions imposed are reproduced in *column* 1. The point estimate of the productivity effect is very close to unity, and a Wald test does not reject setting the parameter equal to one. The estimated parameters with the restriction $a_1 = 1$ imposed are given in *column* 2 of the table. All variables, except *ALMPs* and the replacement rate in the *UI* system are significant at conventional levels according to t-tests on the parameters in *column* 2. However, a Wald test forcefully rejects setting $a_1 = 1$; $a_3 = a_7 = 0$ or $a_1 = 1$; $a_3 = 0$, whereas $a_1 = 1$; $a_7 = 0$ is accepted. The estimates with the latter restrictions imposed are given in *column* 3. This is, according to the tests, the preferred specification. Tests for the presence of deterministic trends in this model allow us to exclude all deterministic trends of order ≤ 5 .

Looking at the point estimates, we note the following:

⁷⁰The Gauss code, implementing *CCR*, was most kindly supplied by Per Jansson, Bank of Sweden.

Table 10: *CCR* estimates of baseline model. Dependent variable: The Product real wage rate^a

	1	2	3
<i>const</i>	-0.69 (0.18)	-0.72 (0.04)	-0.73 (0.05)
<i>q</i>	0.998** (0.033)	1 - ^b	1 - ^b
<i>u</i>	-0.033** (0.011)	-0.039** (0.007)	-0.041** (0.007)
γ	-0.029 (0.019)	-0.022 (0.015)	-0.033** (0.014)
θ	0.199** (0.050)	0.203** (0.027)	0.205** (0.029)
$p_I - p_p$	-0.091** (0.024)	-0.085** (0.022)	-0.090** (0.025)
<i>rip</i>	-0.153** (0.032)	-0.154** (0.030)	-0.167** (0.031)
ρ	-0.029 (0.032)	-0.034 (0.031)	

^a Estimated standard errors in parentheses. Double asterisks indicate that the estimate is significantly different from zero at the 1% level according to t-tests. The estimated parameters derive from the third-step estimates, whereas Wald tests are performed using the fourth-step estimates.

^b The estimate is imposed.

1. The (highly statistically significant) effect of open unemployment equals -0.04 . This, once again, is lower than the effect found in most previous studies.
2. The effect of *ALMPs* is negative, thus indicating that, in contrast to most previous findings, labour market policies may actually contribute to wage moderation.
3. Higher taxes contribute to wage pressure, also in the long run. The estimated elasticity with respect to the tax wedge is about 20%.
4. A higher relative import price contributes to wage moderation. The size of the estimated parameter is just below 10%. Although the

sign may be surprising, we cannot rule it out *a priori*.

5. Higher progressivity in the income tax system seems to add to, rather than reduce, the wage pressure. The size of the elasticity is just below 15%.
6. Finally, like in most previous studies (but unlike the results in our systems estimation), we do not find any significant effect of the replacement rate in the *UI* system.

8 What accounts for the new results?

We have seen that our results concerning the effect of *ALMPs* on wage pressure are somewhat at odds with the main body of previous results, which indicate that extensive *ALMPs* tend to increase wage pressure. An important question is what accounts for this difference.

Up to now, we have looked at a number of possible explanations: a longer sample period, different specification of the labour market variables and other estimation methods. Neither of these possible explanations have really provided any clue as to what accounts for the difference.

We now proceed and look at another two possible explanations: different models and different data. To accomplish this, we estimate the model proposed in the influential papers by Calmfors and Forslund (1990) and Calmfors and Forslund (1991) on our data set, both using their original sample period (ending in 1986) and our full sample. If we still do not find any significant effect of *ALMPs* on wage pressure, our conclusion will be that (by default) our new results derive from new data.⁷¹

The estimated model proposed by Calmfors and Forslund (1990) and Calmfors and Forslund (1991) is most easily presented in a table with the estimated parameters. We choose to present two of their different specifications in *Table 11*.

There are a number of differences between our modelling and the models estimated by Calmfors and Forslund. Here we list a few of those differences:

⁷¹Unfortunately, the original data used by Calmfors and Forslund are not available; the main differences between our data and theirs derive from revisions in the National Accounts Statistics and new computations of income tax rates. Given their data, we could have estimated our models on their original data to check for differences.

Table 11: Estimated real wage equations from Calmfors and Forslund (1990). Dependent variable: the log of the product real wage rate^a

Variable	1	2
const	2.99 (26.7)	1.58 (3.86)
$\log(1 + R + U)$	-1.84 (1.58)	-1.53 (2.52)
γ	0.15 (3.98)	0.22 (11.07)
θ	0.73 (5.33)	0.83 (6.48)
$\Delta^2 p_c$	-0.39 (1.91)	-0.42 (2.08)
t	0.049 (5.36)	
t^2	$-7.3 \cdot 10^{-4}$ (4.38)	
q		0.48 (4.38)

^a The numbers in the parentheses are (absolute) t-values. $\Delta^2 p_c$ is the change of the change in the log of the consumer price index, which approximately equals the change in the inflation rate and t is time.

1. The specification of “total unemployment” is slightly different (roughly corresponding to the unlogged rate; $\log(1 + U + R) \approx (U + R)$ for small numbers).⁷² This would roughly imply that a change in total unemployment from 1 per cent to 2 per cent would have the same effect as a change from 5 per cent to 6 per cent.
2. All trends are assumed to be deterministic in *model 1* in *Table 11*; in *model 2* the whole question of non-stationarity is ignored.
3. Calmfors and Forslund introduce the change in the inflation rate to capture expectational errors in wage setting. We have not used any counterpart to that variable in the present study.

⁷² R is the fraction of the labour force in *ALMPs*.

4. Calmfors and Forslund lump the tax and the price part of the wedge between the product real wage rate and the consumption real wage rate together; we add them separately.

In *Table 12* we show the results of re-estimating the two models in *Table 11* using our data set (both for the period 1960–86 and the period 1960–1997). We do this using *IV* methods and the instruments suggested by Calmfors and Forslund (1990). Unemployment is treated as an endogenous variable, whereas the accommodation rate is assumed to be an exogenously given policy variable.

Table 12: The models of Calmfors and Forslund (1990) re-estimated on new data^a

Variable	1a: 1960–97	1b: 1960–86	2a: 1960–97	2b: 1960–86
<i>const</i>	3.335 (25.21)	3.357 (23.25)	-0.078 (0.214)	0.087 (0.126)
$\log(1 + r + u)$	0.676 (1.318)	-0.865 (0.414)	-0.648 (1.076)	-4.536 (1.821)
γ	-0.048 (0.828)	0.060 (0.890)	0.067 (1.647)	0.114 (1.579)
θ	-0.079 (1.305)	0.372 (2.816)	0.077 (1.410)	0.175 (1.940)
$\Delta^2 p_c$	0.218 (0.895)	-0.424 (1.188)	-0.173 (0.657)	-0.552 (1.318)
<i>t</i>	0.089 (9.492)	0.087 (8.387)		
t^2	$-1.2 \cdot 10^{-3}$ (7.493)	$-1.6 \cdot 10^{-3}$ (7.783)		
<i>q</i>			0.951 (12.197)	0.937 (6.402)

^a The numbers in the parentheses are (absolute) t-statistics. Total unemployment, the tax-price wedge and productivity have been treated as endogenous variables; public employment, the labour force the logs of the income tax rate, the payroll tax rate and the VAT have been used as instruments (as have the trend and the squared trend).

Looking first at the estimated effect of *ALMPs* in *Table 12*, we see that, even ignoring potential problems of inference related to non-stationarity, the effect is never significantly different from zero. The point estimates are also in all cases lower than their counterparts in *Table 11*. This holds irrespective of sample period and specification. Looking at different tests

for mis-specification (not reproduced in the table), we also have clear indications of mis-specifications in all four equations.⁷³

It is also fairly easy to see that the point estimates are unstable between specifications and sample periods. Hence, we do not comment any further on the point estimates.

Let us summarise: Comparing the estimates of the model of Calmfors and Forslund on their original data with the estimates on our new data set, they are very different.⁷⁴ Given the point of departure for this exercise, we, hence, believe that the difference between our results and the results in earlier studies primarily reflect new data.

Which, then, are the main novelties in our data set? *First*, we have computed a completely new income tax rate series. *Second*, all the data that derive from the National Accounts Statistics have undergone several revisions since the late 1980s, some of which have resulted in substantially revised series for a number of variables in especially the 1980s. Apparently, these changes have meant a lot to the estimates of aggregate wage equations.

9 Concluding comments

In this paper, the main issue is the effect of *ALMP* participation on aggregate wage pressure in the Swedish economy. To analyse this issue, we estimate wage-setting schedules on data for the Swedish private sector using three different estimation strategies: we use Johansen's (1988) *FIML* method to estimate a long-run wage-setting schedule in the framework of a system of equations; we estimate a single-equation error-correction model; and, finally, we look for a long-run wage-setting schedule using Park's (1992) notion of canonical cointegrating regressions. A natural way to look at the results is to compare the estimates derived via these three routes. This is done in *Table 13*.

Comparing the three sets of estimates, we find both differences and similarities. Especially the two single-equation methods produce rather

⁷³An example is that the Durbin-Watson statistic in *equation 1a* equals 0.66, that the Sargan test rejects instrument validity and that there is significant ARCH 1 and heteroskedasticity in the same equation.

⁷⁴We have not used exactly the same estimation technique as Calmfors and Forslund (they used an iterative three-stage least squares method), so this could still make a small difference.

Table 13: Estimated long-run wage-setting schedules. Dependent variable: Labour’s share of value added^a

Variable	Johansen	Error correction	CCR
Unemployment (u)	-0.026	-0.051	-0.041
Accommodation rate (γ)	0.067	0	-0.033
Tax wedge (θ)	0	0.162	0.205
Relative import price ($p_I - p_P$)	0	0	-0.090
Tax progressivity (rip)	-	-0.076	-0.167
Replacement rate (ρ)	0.316	0	0

^a All variables are in logs. Johansen denotes the results of the Johansen *FIML* estimations, Error correction the estimated error-correction model and *CCR* the canonical cointegrating regression results.

similar results.

First, regarding the effects of *ALMPs* on wage pressure, two of the three point estimates point to no effect or a negative effect, much in contrast to earlier results. The third point estimate, resulting from the preferred Johansen procedure, is positive, but we can impose a zero restriction in a similar set-up. Hence, most of the evidence is consistent with *ALMPs* exerting no upward pressure on the wage-setting schedule. This may reflect changes in the labour market or the labour market policies and would be consistent with a notion that “low-budget” *ALMPs* with low compensation to participants and small if any positive effects on the probability of finding a job do not contribute to an increased wage pressure. This idea is, however, at odds with the finding in the recursive estimations of the error-correction model that the parameter is fairly constant since the late 1980s, close to zero and imprecisely estimated for all sub-samples we looked at.

Second, the wage-setting schedule is, according to all estimated models, negatively sloped: there is a significantly negative effect of unemployment on the real wage rate. The point estimates are rather low (ranging between -0.026 and -0.051) compared to the results in earlier studies, but, once again, recursive parameter estimates in the error-correction model did not reveal any signs of parameter instability with respect to the effect of unemployment on wages.

Third, according to the two single-equation estimates, taxes contribute to long-run wage pressure: raising the tax wedge by 10% contributes to

an increase in wage pressure by between 1.5% and 2% according to the point estimates. According to the systems estimates, on the other hand, there is no significant effect.

Fourth, in two of the three models there is no impact of relative import prices on wages. In the third, the canonical cointegrating regressions model, there is a significant downward effect on wage pressure from higher import prices.

Fifth, a higher income-tax progressivity, i.e., a lower coefficient of residual income progressivity, contrary to what we expect from theory, results in higher wage pressure according to two of the three estimated models (the residual income progressivity measure was not included in the Johansen estimates). The recursive estimates of the error-correction model, however, indicate some parameter instability occurring in 1991, the year of the comprehensive tax reform.

Finally, the replacement rate in the *UI* system is significant (with the expected sign) only in the Johansen estimates. Although not consistent with our theoretical framework, this is a standard finding.

Having seen that the different methods produce (slightly) different results, what should we believe in? *First*, given that different estimators behave differently under different conditions, we feel inclined to believe most in the results that are common to all modelling efforts. This would leave us most confident about the results pertaining to the effect of *ALMPs* and unemployment. *Second*, given that we have a small sample, there are reasons to interpret the results of the Johansen estimates with some care, partly because the number of degrees of freedom is smaller than for the other methods, partly because we would need a Monte-Carlo evaluation of the properties of the tests in this situation. Thus, we tend to believe more in the single-equation estimates. This belief is further reinforced by our problems with identifying cointegrating relations with clear theory based interpretations in the Johansen analysis. Thus, we tend to believe more in the results pertaining to taxes (derived in the single-equation models) than in the (theory-consistent) result for the replacement rate derived in the Johansen analysis.

Our result regarding the effect of *ALMPs* on wage pressure are at odds with the results in a majority of the previous studies of aggregate Swedish wage setting. To see what accounts for this difference, we have performed a systematic comparison between our estimated models and the models estimated by Calmfors and Forslund (1990). We have also experimented

with different specifications of the measures of the *ALMPs*.

These exercises have shown that our baseline specification stands up well to alternative specifications found in the literature. Our prime suspect behind the differences in results instead turns out to be data revisions.

References

- ACKUM AGELL, S. (1996): “Arbetslösas Sökaktivitet,” Appendix to SOU 1996:34, Aktiv Arbetsmarknadspolitik, Stockholm.
- BANERJEE, A., J. J. DOLADO, J. W. GALBRAITH, AND D. F. HENDRY (1993): *Co-Integration, Error Correction and the Econometric Analysis of Non-Stationary Data*. Oxford University Press, Oxford.
- BEAN, C. (1994): “European Unemployment: A Survey,” *Journal of Economic Literature*, XXXII, 573–619.
- BEAN, C., R. LAYARD, AND S. NICKELL (1986): “The Rise in Unemployment: A Multi-Country Study,” *Economica*, 53, S1–S22.
- BINDER, M. (1997): “Aktiv Arbejdsmarkedspolitik og Økonomisk Marginalisering—En Teoretisk Analyse af den Aktive Arbejdsmarkedspolitik's Langsigtede Virkninger på Ledighedens Størrelse og Fordeling,” Ph.D. thesis, Department of Economics, University of Copenhagen.
- BRÄNNÄS, K., AND H. OHLSSON (1999): “Asymmetric Time Series and Temporal Aggregation,” *The Review of Economics and Statistics*, 81, 341–344.
- CALMFORS, L. (1994): “Active Labour Market Policy and Unemployment. A Framework for the Analysis of Crucial Design Features,” *OECD Economic Studies*, 22, 7–47.
- CALMFORS, L., AND A. FORSLUND (1990): “Wage Formation in Sweden,” in *Wage Formation and Macroeconomic Policy in the Nordic Countries*, ed. by L. Calmfors. SNS and Oxford University Press, Stockholm.
- (1991): “Real-Wage Determination and Labour Market Policies: The Swedish Experience,” *The Economic Journal*, 101, 1130–1148.
- CALMFORS, L., AND H. LANG (1995): “Macroeconomic Effects of Active Labour Market Programmes in a Union Wage-Setting Model,” *The Economic Journal*, 105, 601–619.
- CALMFORS, L., AND R. NYMOEN (1990): “Nordic Employment,” *Economic Policy*, 5, 397–448.

- DAHLBERG, M., AND A. FORSLUND (1999): "Direct Displacement Effects of Labour Market Programmes: The Case of Sweden," Working Paper 1999:7, Office of Labour Market Policy Evaluation, Uppsala.
- DOORNIK, J. A. (1998): *Ox. An Object-Oriented Matrix Programming Language*. Timberlake Consultants Ltd, West Wickham, 2 edn.
- DOORNIK, J. A., AND D. F. HENDRY (1997): *Modelling Dynamic Systems Using PcFiml 9.0 for Windows*. International Thomson Business Press, London.
- EDIN, P.-A. (1989): "Individual Consequences of Plant Closures," Phd thesis, Department of Economics, Uppsala University.
- EDIN, P.-A., AND B. HOLMLUND (1991): "Unemployment, Vacancies and Labour Market Programmes: Swedish Evidence," in *Mismatch and Labour Mobility*, ed. by F. Padoa-Schioppa. Cambridge University Press, Cambridge.
- EDIN, P.-A., B. HOLMLUND, AND T. ÖSTROS (1995): "Wage Behaviour and Labour Market Programmes in Sweden: Evidence from Micro Data," in *Labour Market and Macroeconomic Performance in Europe, Japan and the US*, ed. by Tachibanaki. Macmillan, London.
- ENGLE, R., AND C. GRANGER (1987): "Co-Integration and Error Correction: Representation, Estimation, and Testing," *Econometrica*, 55, 251–276.
- FORSLUND, A. (1992): "Arbetslöshet och Arbetsmarknadspolitik," Appendix 7 to the Medium Term Survey of the Swedish Economy 1992, Ministry of Finance, Stockholm.
- (1994): "Wage Setting at the Firm Level—Insider versus Outsider Forces," *Oxford Economic Papers*, 46, 245–261.
- (1995): "Unemployment—Is Sweden Still Different?," *Swedish Economic policy Review*, 2(1), 17–58.
- (1997): "Lönebildningen och arbetsmarknadens funktionssätt," Appendix 1 to SOU 1997:164, Ministry of Labour, Stockholm.

- FORSLUND, A., AND A. B. KRUEGER (1997): "An Evaluation of the Swedish Active Labor Market Policy: New and Received Wisdom," in *The Welfare State in Transition. Reforming the Swedish Model*, ed. by R. B. Freeman, R. Topel, and B. Swedenborg. University of Chicago Press, Chicago.
- FORSLUND, A., AND O. RISAGER (1994): "Wages in Sweden. New and Old Results," Memo 1994-22, University of Aarhus, Institute of Economics.
- FUKUSHIMA, Y. (1998): "Active Labour Market Programmes and Unemployment in a Dual Labour Market," Research Paper 1998:2, Department of Economics, Stockholm University.
- GRAMLICH, E. M., AND B.-C. YSANDER (1981): "Relief Work and Grant Displacement in Sweden," in *Studies in Labor Market Behavior: Sweden and the United States*, ed. by G. Eliasson, B. Holmlund, and F. P. Stafford. The Industrial Institute for Economic and Social Research, Stockholm.
- HENDRY, D. F. (1995): *Dynamic Econometrics*. Oxford University Press, Oxford.
- HENDRY, D. F., AND J. A. DOORNIK (1996): *Empirical Econometric Modelling Using PcGive 9.0 for Windows*. International Thomson Business Press, London.
- HOLMLUND, B. (1989): "Wages and Employment in Unionized Economies: Theory and Evidence," in *Trade Unions, Employment, and Unemployment Duration*, ed. by B. Holmlund, K.-G. Löfgren, and L. Engström. Oxford University Press, Oxford.
- (1990): "Svensk Lönebildning—Teori, Empiri, Politik," Appendix 24 to the Medium Term Survey of the Swedish Economy 1990, Ministry of Finance, Stockholm.
- HOLMLUND, B., AND A.-S. KOLM (1995): "Progressive Taxation, Wage Setting and Unemployment: Theory and Swedish Evidence," *Swedish Economic Policy Review*, 2, 425–460.
- HOLMLUND, B., AND J. LINDÉN (1993): "Job Matching, Temporary Public Employment and Equilibrium Unemployment," *Journal of Public Economics*, 51, 329–343.

- JOHANSEN, S. (1988): "Statistical Analysis of Cointegrating Vectors," *Journal of Economic Dynamics and Control*, 12, 231–254.
- (1995): *Likelihood-Based Inference in Cointegrated Vector Autoregressive Models*. Oxford University Press, Oxford.
- JOHANSSON, S., P. LUNDBORG, AND J. ZETTERBERG (1999): *Massarbetslöshetens Karaktär*. The Trade Union Institute for Economic Research, Stockholm, 2nd revised edn.
- KREMERS, J. J. M., N. ERICSSON, AND J. DOLADO (1992): "The Power of Cointegration Tests," *Oxford Bulletin of Economics and Statistics*, 54, 325–348.
- LARSEN, B. (1997): "Active Labour Market Programmes and Loss of Skill," mimeo.
- LAYARD, R., AND S. NICKELL (1990): "Is Unemployment Lower If Unions Bargain over Employment?," *Quarterly Journal of Economics*, 105, 773–787.
- LAYARD, R., S. NICKELL, AND R. JACKMAN (1991): *Unemployment—Macroeconomic Performance and the Labour Market*. Oxford University Press, Oxford.
- LO (1951): *Fackföreningsrörelsen och den fulla sysselsättningen*. LO, Stockholm.
- LOCKWOOD, B., AND A. MANNING (1993): "Wage Setting and the Tax System: Theory and Evidence for the United Kingdom," *Journal of public Economics*, 52, 1–29.
- LÖFGREN, K.-G., AND M. WIKSTRÖM (1991): "Lönebildning och Arbetsmarknadspolitik," Appendix to Ds 1991:53 Arbetsmarknad och arbetsmarknadspolitik, Ministry of Labour, Stockholm.
- (1997): "Undanträngningseffekter av Arbetsmarknadspolitik. Kommentarer till Forslund-Sjöstrand Kontroversen," *Arbetsmarknad & Arbetsliv*, 3, 211–223.
- MANNING, A. (1992): "Multiple Equilibria in the British Labour Market," *European Economic Review*, 36, 1333–1365.

- (1993): “Wage Bargaining and the Phillips Curve: The Identification and Specification of Aggregate Wage Equations,” *Economic Journal*, 103, 98–118.
- NEWELL, A., AND J. SYMONS (1987): “Corporatism, Laissez-Faire and the Rise in Unemployment,” *European Economic Review*, 31, 567–614.
- PARK, J. Y. (1992): “Canonical Cointegrating Regressions,” *Econometrica*, 60, 119–143.
- RAAUM, O., AND F. WULFSBERG (1997): “Unemployment, Labour Market Programmes and Wages in Norway,” *Arbeidsnotater* 11, Norges Bank.
- RICHARDSON, J. (1997): “Can Active Labour Market Policy Work?—Some Theoretical Considerations,” Discussion Paper 331, Centre For Economic Performance, London School of Economics.
- RØDSETH, A., AND R. NYMOEN (1999): “Nordic Wage Formation and Unemployment Seven Years Later,” Memorandum 10/99, Department of Economics, University of Oslo.
- SJÖSTRAND, K.-M. (1997): “Några Kommentarer till Anders Forslunds Rapport ’Direkta Undanträngningseffekter av Arbetsmarknadspolitiska Åtgärder’,” mimeo, National Labour Market Board, Stockholm.

Appendix

A The data

A1 Introduction

In this appendix a rather detailed description of the data used in the study is provided. Thus, the description includes information on time-series and other properties of the variables in addition to graphs, definitions, data sources and, when applicable, the methods used to derive the variables.⁷⁵ Our data set consists of annual data over the period 1960–1997. We use annual data partly to cover as long a time span as possible in order to be able to discuss long-run properties of the variables, partly because there is no variation during a year in some of our variables (for example the income tax rates) and partly to avoid measurement errors in higher-frequency series. The information is presented by variable (or group of variables).

A1.1 A digression on data description

When describing time series data, there are a number of obvious things to report. First, plots of data against time give a good intuition for their characteristic properties (at least for the trained observer): one can see if a variable appears to be trended, if there are variations both in the short and in the long run, if there seem to be breaks between different "regimes" and so on. Thus, we plot the data. It is also useful to learn something about the unconditional distribution of a variable, disregarding the time dimension. In particular, it is valuable for the sake of inference to find out how far from normally distributed a variable is. To account for this, we plot a smoothed transformation of the density function and compare it to a normal distribution both by way of graphs and a formal normality test. Finally, the time series properties of a variable are of crucial importance for the possible ways of modelling its variations over time. We describe the time series properties of variables by plots of correlograms and spectral densities. This is supplemented by formal unit-root tests. The unit-root

⁷⁵The plots and the descriptive statistics have been produced using Ox 2.0 (Doornik, 1998) and PcGive 9.10 (Hendry and Doornik, 1996). The plots have been included in encapsulated post-script format.

tests are *ADF* tests, where the strategy has been to include both a constant and a trend in the test equations in the cases where the time-series plots suggest the possibility of a trended series. The number of lags has been chosen as the minimum number of lags necessary to produce error terms without significant serial correlation.⁷⁶

A2 Wages

The nominal wage measure used pertains to the business sector and is generated as the ratio between the total wage sum (including employers' contributions to social security, henceforth called payroll taxes) and the total number of hours worked by employees in the business sector. To get the product real wage, the wage series is deflated by a measure of producer prices. The price series used is the implicit deflator for value added in the business sector at producer prices. The data are taken from the National Accounts statistics.⁷⁷ The use of the National Accounts statistics is dictated by our wish to cover the whole business sector, for which no direct measure of the hourly wage rate is available for our period.

A2.1 The nominal wage cost

The nominal hourly wage cost (panel 1) along with its correlogram (panel 2), spectral density (panel 3), density (panel 4) and a “QQ-plot” comparison with a normal distribution (panel 5) are plotted in *Figure A1*.⁷⁸ The logarithmic transformation and its first difference are displayed in *Figures A2* and *A3*. The hourly wage cost is clearly upward trended and highly serially correlated with most of its spectral density at low frequencies. It is also far from normally distributed. The same is true of its logarithm. This is, hardly surprising, corroborated by formal normality tests in *Table A1*. Neither is it surprising that unit roots in the levels or log series cannot be rejected, whereas the logarithmic difference seems to

⁷⁶For a good discussion of unit-root testing and other issues related to the modelling of non-stationary time series, see Banerjee, Dolado, Galbraith, and Hendry (1993).

⁷⁷Numbers from reports N 1975:98, N1981:2, N 10 1985 and N 10 1997 from Statistics Sweden have been chained. This procedure has been followed for all series based on the National Accounts. All data for 1997 are taken from preliminary figures published by the National Institute for Economic Research (Analysunderlag varen 1998).

⁷⁸Details of the computations underlying the graphs can be found in Hendry and Doornik (1996).

be stationary (cf. *Table A2*). Looking at the logarithmic difference, the mid 1970s stand out as an exceptional episode with wage cost increases by around 15% a year between 1974 and 1976. It is also rather interesting that the two devaluations in 1981 and 1982 by around 25% are followed by rather modest increases in wage costs.

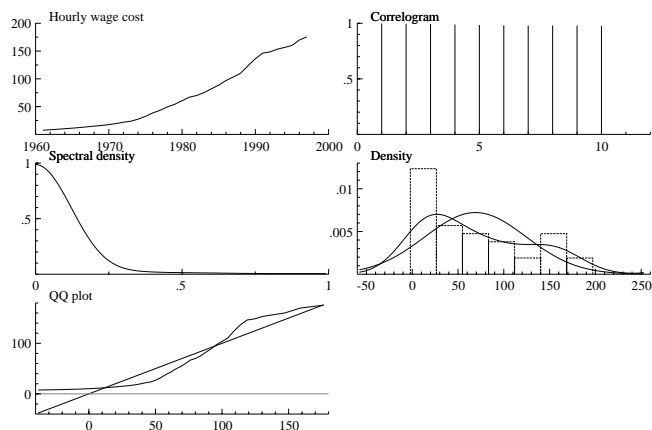

Figure A1: Hourly wage cost 1961–97

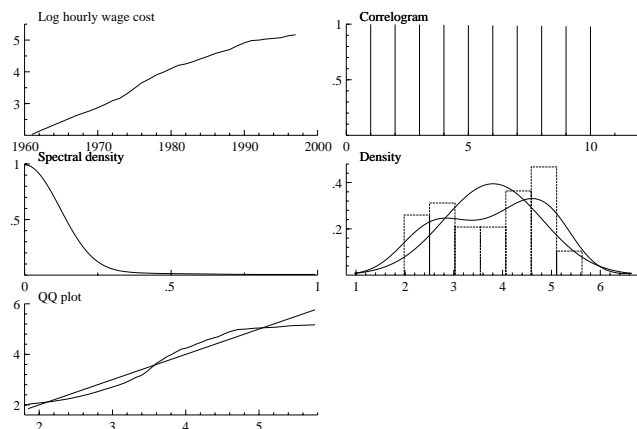

Figure A2: Log hourly wage cost 1961–97

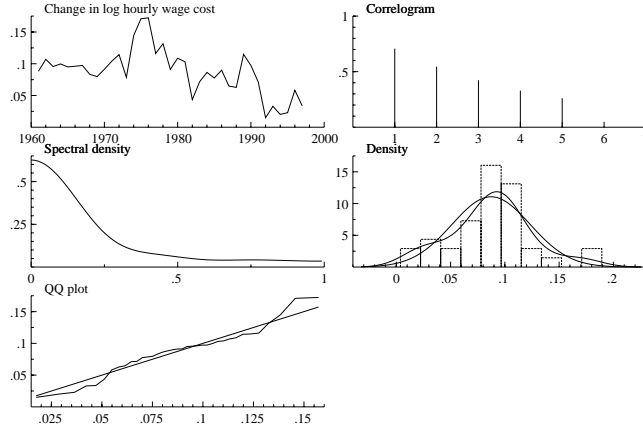

Figure A3: Change in log hourly wage cost 1961–97

A2.2 The product real wage

Figure A4 depicts the development of the (natural) logarithm of the product real wage rate 1961–1997 along with the same types of graphs describing its distribution that were used to describe the nominal wage cost. Corresponding information on its logarithmic change (the growth rate) is given in *Figure A5*. The product real wage is defined as the ratio between hourly wage cost (including payroll taxes) and the deflator for value added in the business sector at producer prices. The product real wage rate is the relevant price index of labour costs for a firm in the business sector. The net real take-home hourly wage rate for an employee can be derived from the product real wage rate by dividing it by a tax-price wedge reflecting payroll taxes, income taxes, indirect taxes and the relative price of value added to imports. More precisely, we have

$$rw_p = \frac{W(1+t)}{P_p} \quad (\text{A1})$$

$$rw_c = \frac{W(1-at)}{P_c}, \quad (\text{A2})$$

where W is the wage rate, rw_p the product real wage rate, rw_c the consumption real wage rate, t the payroll tax rate, P_p the producer price

index, at the average income tax rate and P_c the consumer price index. The wedge between the product real wage and the consumption real wage is consequently given by

$$\hat{\theta} = \frac{1+t}{1-at} \frac{P_c}{P_p}, \quad (\text{A3})$$

where $\hat{\theta}$ denotes the wedge.

If we, for simplicity, assume that consumer prices are a weighted average of domestic prices and import prices (P_I) and take account of value-added taxes (VAT), the consumer price can be written

$$P_c = (1 + VAT)P_p^\lambda P_I^{1-\lambda}, \quad (\text{A4})$$

where λ is the weight of domestic goods in the consumer price index. Thus, the wedge can be decomposed into a part reflecting taxes

$$\theta = \frac{(1+t)(1+VAT)}{1-at}, \quad (\text{A5})$$

where θ will be referred to as the tax wedge, and a part reflecting the relative price between imports and production. The tax wedge, in turn, can be decomposed into a value-added tax factor, $(1 + VAT)$, a payroll tax factor, $(1 + t)$, and an income tax factor, $(1 - at)$.

We do not look explicitly at the consumption real wage rate, but the tax-price wedge and its components are presented in *Section A6* below.

Looking at the first panel in *Figure A5*, it seems that product real wage growth went down around 1980. The levels series in *Figure A4* is, however, clearly upward trended over the period. From the correlogram in the second panel of *Figure A4*, we see that the series is characterised by a very long memory, the autocorrelations hardly dropping below unity during the 10 years reported in the figure. The spectral density reported in the third panel of *Figure A4* also reveals that most mass is concentrated at low frequencies. In the fourth panel the density is plotted and an interpolated density is compared to a normal density. The distribution is easily seen to be right-skewed with a very thick left tail. This is also seen in the fifth panel, where the straight line is the normal distribution.

Looking instead at the rate of change of the product real wage in *Figure A5*, the correlogram indicates some serial correlation, the size of which, however, being far smaller than for the series in levels. The spectrum of the logarithmic change series is also much flatter, indicating a series that

is “closer“ to white noise. Finally, neither the figure nor *Table A1* indicate significant deviations from normality.

As both the levels and the (logarithmic) change series exhibit behaviour that indicates the possible presence of a trend, the unit root tests include a constant and a trend to allow for the possibility of a deterministic trend. In the (logged) levels equation with the trend term present, a unit root is not rejected, whereas the test equation with constant but without trend rejects a unit root. Testing the levels series without a constant and a trend does not, however, lead to a rejection of a unit root. The same test for the change series still rejects the unit root. A tentative conclusion would be that the product real wage is non-stationary, possibly with a deterministic trend.

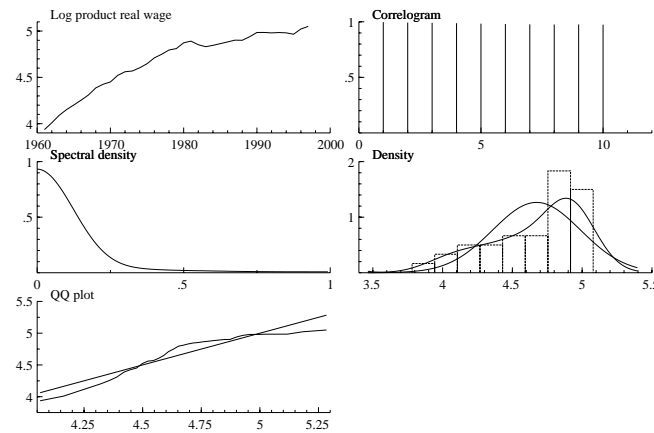

Figure A4: Log product real wage 1961–97

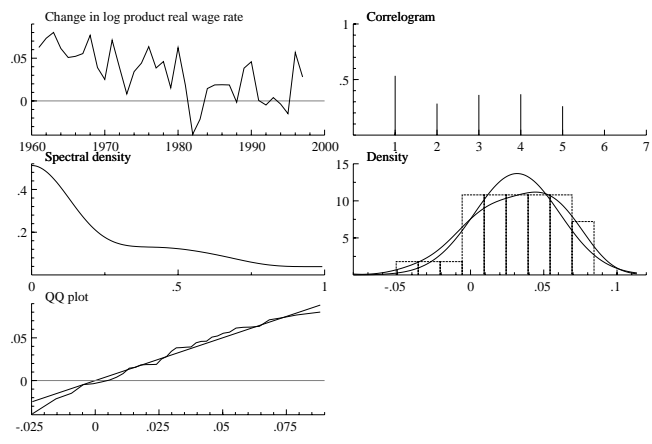

Figure A5: Change in log product real wage 1961–97

A2.3 Labour's share of value added

One possible "explanation" of the failure to reject non-stationarity for the product real wage rate is that it may be cointegrated with labour productivity (which is trended and possibly non-stationary, see below). Such cointegration, with cointegrating vector $(1, -1)$ between the log of the product real wage and the log of labour productivity, would e.g. follow if wages are set in Nash bargains under certain conditions (Layard, Nickell, and Jackman, 1991). Notice that the labour share of value added is given by

$$\frac{W(1+t)N}{P_p Y} = \frac{W(1+t)/P_p}{Y/N}, \quad (\text{A6})$$

or the ratio between the product real wage and labour productivity. Hence, if the log of the product real wage rate and the log of labour productivity are cointegrated with cointegrating vector $(1, -1)$, the log of the labour share of value added should be stationary. To check this, we examine the properties of the labour share in *Figures* A6 and A7 and *Tables* A1 and A2.

The labour share is upward trended from the early 1960s to the early 1980s. Following the two devaluations in 1981 and 1982 as well as in the aftermath of the depreciation of the *Krona* in the early 1990s, the share falls very rapidly. The series is characterised by a fair deal of serial correlation as witnessed by the correlogram and the spectral density in *Figure* A6. The serial correlation is, however, much lower than for the product real wage rate. Normality is not rejected. Most of the serial correlation is taken away by first-differencing the series, as can be seen in the correlogram and spectral density of the logarithmic difference of the labour share in *Figure* A7. Also the first-differenced series seems to be well described as normally distributed. The unit-root tests reported in *Table* A2, however, suggest that the labour share of value added is an $I(1)$ variable. This, in turn, indicates that the real wage rate and labour productivity are not cointegrated with cointegrating vector $(1, -1)$.

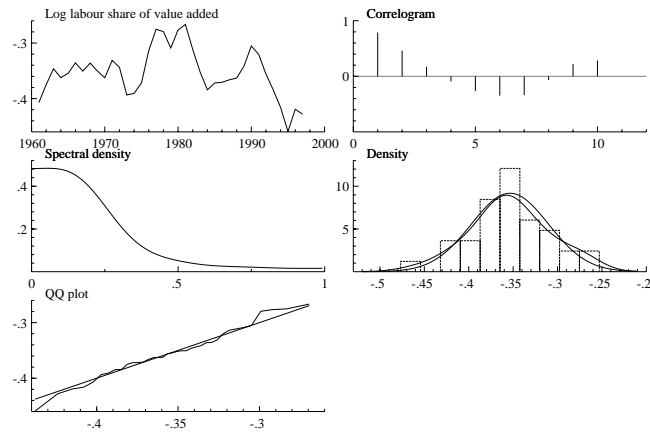

Figure A6: Log labour share of value added 1961–1997

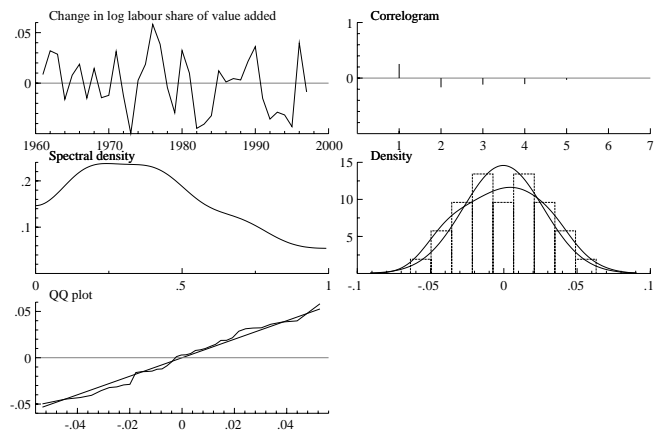

Figure A7: Change in log labour share of value added 1961–1997

Table A1: Normality tests for wage variables

Variable	Mean	Std. Devn.	Skewness	Normality χ^2
Hourly wage cost	69.10	5.28	0.55	12.71 [0.002]
Change in hourly wage cost	4.56	3.28	0.86	6.54 [0.038]
Log hourly wage cost	3.81	1.01	-0.25	7.59 [0.022]
Change in log hourly wage cost	0.087	0.036	0.09	1.76 [0.415]
Log product real wage rate	4.67	0.32	-0.82	13.97 [0.001]
Change in log product real wage rate	0.032	0.029	-0.34	1.52 [0.467]
Log labour share of value added	-0.35	0.04	-0.02	0.45 [0.796]
Change in log of labour share of value added	0.00	0.03	0.01	0.89 [0.640]

Table A2: *ADF* tests for wage variables

Variable	# lags	Trend included	t-statistic	Critical value
Hourly wage cost	1	yes	-2.145	-3.574
Change in hourly wage cost	0	yes	-3.210	-3.551
Change in hourly wage cost	0	no	-2.575	-2.953
Log hourly wage cost	1	yes	-0.072	-3.547
Log hourly wage cost	1	no	-1.989	-2.953
Change in log hourly wage cost	0	yes	-2.891	-3.551
Change in log hourly wage cost	0	no	-2.066	-2.953
Log product real wage rate	0	yes	-1.979	-3.547
Log product real wage rate	0	no	-4.308**	-2.953
Change in log product real wage rate	0	yes	-4.322**	-3.551
Change in log product real wage rate	0	no	-3.601*	-2.953
Log labour share of value added	1	yes	-2.443	-3.547
Log labour share of value added	1	no	-2.224	-2.953
Change in log of labour share of value added	0	yes	-4.410**	-3.551
Change in log of labour share of value added	0	no	-4.369**	-2.953

A3 Unemployment

The number of unemployed persons is the standard measure given by the Labour Force Surveys (*LFS*) performed by Statistics Sweden.⁷⁹ This number of persons is turned into an unemployment rate by relating it to the labour force. The measure of the labour force is not the one supplied by the *LFS*. Instead, the labour force is derived as the sum of employment according to the National Accounts statistics, unemployment according to the *LFS* and participation in active labour market policy measures (*ALMPs*) according to statistics from the National Labour market Board.⁸⁰ This “non-standard” definition of the labour force is used first because the *LFS* measure is not available prior to 1963 and second because it seems natural to include programme participants, as active job search and joblessness are necessary conditions for programme eligibility.

Figure A8 reproduces the development of the unemployment rate and the same graphs characterising its distribution as were displayed for the product real wage. *Figure A10* gives the same information about the logged unemployment rate and *Figures A9* and *A11* about the changes in the level and log unemployment rates respectively.

The variation in the unemployment rate is completely dominated by the dramatic rise in the early 1990s. Prior to this the series exhibits a clear cyclical pattern with every peak slightly higher than its predecessor. The correlogram and the graph of the spectral density both show that there is a great deal of persistence in the series (see *Figures A8* and *A10*). The high autocorrelation at 10 years most likely reflects that the three episodes with the largest increases in the unemployment rate have taken place at ten-year intervals in the early 1970s, 80s and 90s. The serial correlations in the first-difference series (*Figures A9* and *A11*) are lower, but still significant. Neither the levels, the log series nor their first differences are even close to being normally distributed (as revealed by the graphs and confirmed by the formal tests in *Table A3*). Among other things, this reflects the fact that the development of the unemployment rate seems asymmetric: although the level of unemployment is significantly higher at the end of the sample period than at the beginning, there are fewer observations at

⁷⁹Due to changes in both definitions and methods of measurement, there are breaks in the *LFS* unemployment series. The present series is chained by multiplying the old series by the ratio between it and the new one at common observations.

⁸⁰Only those programme participants who are not included among the employed are, of course, added.

which the unemployment rate has increased than decreased (Brännäs and Ohlsson, 1999).

Unit roots cannot be rejected in levels, even allowing for a deterministic trend, whereas they are rejected for the series in first-difference form. This would indicate that the unemployment rate behaves like an $I(1)$ series in our sample period. This should not be taken too literally, especially concerning the levels series, which is bounded by 0 and 1, and hence its variance cannot grow indefinitely as time goes to infinity.⁸¹ It is also important to remember that the failure to reject the null of non-stationarity does not entail accepting a unit root; it may, for example, reflect other forms of non-modelled non-stationarity such as regime shifts.

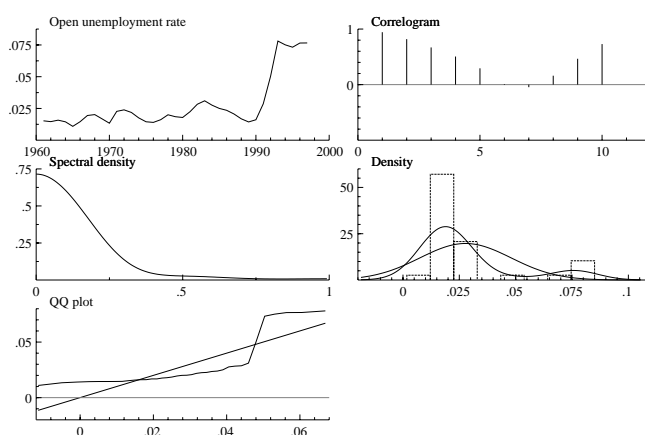

Figure A8: Unemployment rate (share of labour force) 1961–97

⁸¹The variance of an $I(1)$ process $y_t = y_{t-1} + u_t$ grows as $t\sigma^2$ if the variance of u_t equals σ^2 .

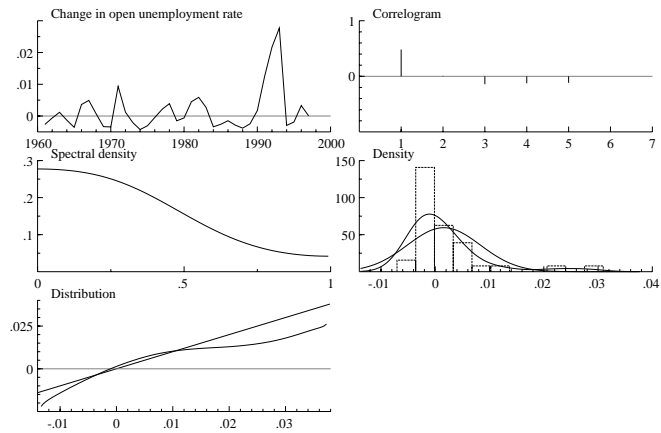

Figure A9: Change in the unemployment rate 1961–97

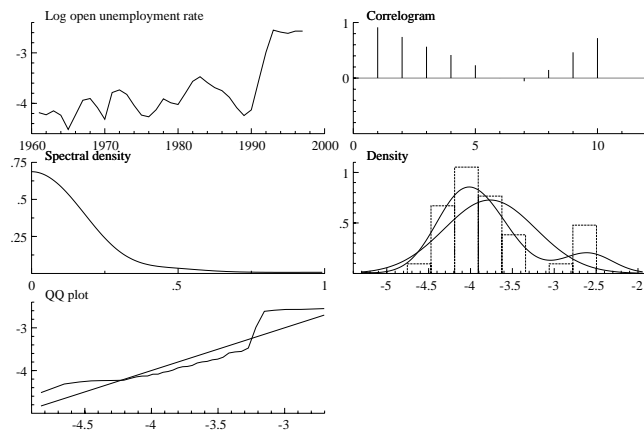

Figure A10: Log unemployment rate 1961–97

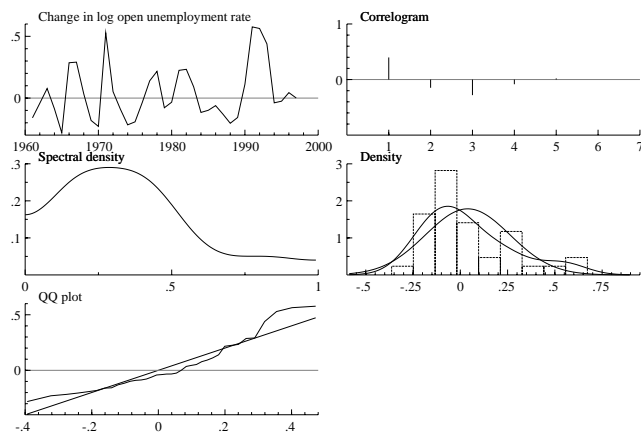

Figure A11: Change in the log of the unemployment rate 1961–97

Due to the large volumes of active labour market programmes (*ALMPs*), the open unemployment rate gives an incomplete picture of the extent of joblessness in the Swedish economy. Because of this and because the role of *ALMPs* is one of the key factors of interest in our study of aggregate Swedish wage setting, we reproduce information about a measure of "total unemployment" in the Swedish economy (derived by adding the participation rate in *ALMPs* to the open unemployment rate) in levels, logs and logarithmic differences in *Figures A12, A13, A14 and A15 and Table A3* below. We also present measures of *ALMPs* below in *Section A4*.

Apart from the obvious fact that the total unemployment rate exceeds the open unemployment rate, the general characteristics of the two series are very similar. Thus, there is a great deal of persistence, the distribution is skewed, a unit root cannot be rejected in the levels series, whereas it can in the first-differenced series in both the original and logged series. The conclusion is that also the total unemployment rate behaves as an $I(1)$ series (see *Table A4*).

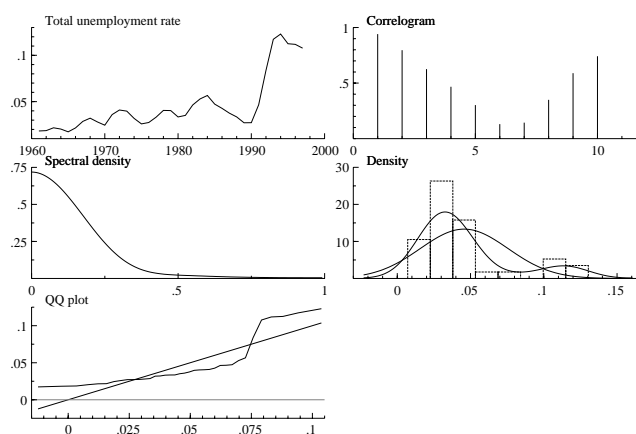

Figure A12: Total unemployment rate (share of labour force) 1960–97

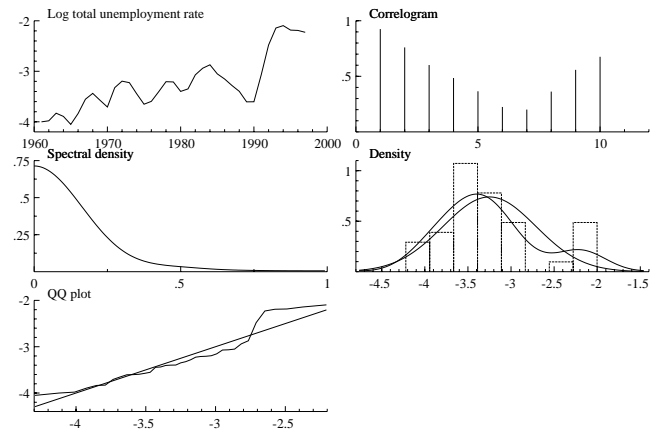

Figure A13: Log total unemployment rate 1960–97

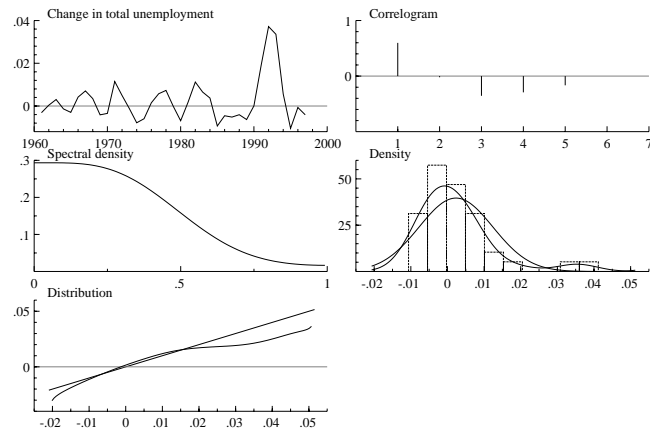

Figure A14: Change in total unemployment rate 1961–1997

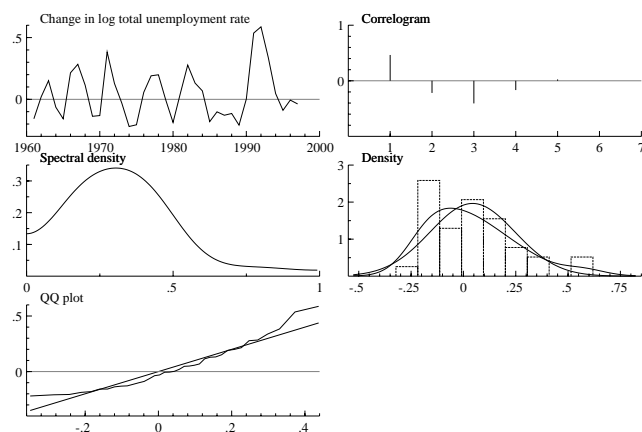

Figure A15: Change in log total unemployment rate 1961–1997

Table A3: Normality tests for labour market variables

Variable	Mean	Std. Devn.	Skewness	Normality χ^2
Unemployment rate	0.028	0.020	1.75	80.19 [0.000]
Change in the unemployment rate	0.002	0.007	2.35	52.49 [0.000]
Log unemployment rate	-3.766	0.549	1.20	24.01 [0.000]
Change in the log of the unemployment rate	0.039	0.223	0.94	10.44 [0.005]
Total unemployment rate	0.046	0.030	1.56	49.94 [0.000]
Change in total unemployment rate	0.002	0.010	1.87	25.80 [0.000]
Log total unemployment rate	-3.250	0.539	0.78	7.23 [0.027]
Change in log total unemployment rate	0.044	0.203	0.86	6.97 [0.031]
Accommodation ratio	0.398	0.084	-0.62	2.88 [0.237]
Change in accommodation ratio	0.003	0.048	-0.26	0.84 [0.658]
Log accommodation ratio	-0.949	0.244	-1.38	11.87 [0.003]
Change in log accommodation ratio	0.015	0.127	0.01	0.08 [0.961]
Programme participation rate	0.018	0.010	1.04	10.24 [0.006]
Change in programme participation rate	0.001	0.005	0.64	5.21 [0.074]
Log programme participation rate	-4.199	0.621	-0.43	1.55 [0.461]
Change in log programme participation rate	0.059	0.229	0.266	0.97 [0.614]

Table A4: *ADF* tests for labour market variables

Variable	# lags	Trend included	t-statistic	Critical value
Unemployment rate	1	yes	-2.297	-3.547
Unemployment rate	1	no	-1.110	-2.953
Change in the unemployment rate	0	yes	-3.368	-3.551
Change in the unemployment rate	0	no	-3.311*	-2.953
Log unemployment rate	1	yes	-3.018	-3.547
Log unemployment rate	1	no	-1.489	-2.953
Change in the log of the unemployment rate	1	yes	-4.479**	-3.551
Change in the log of the unemployment rate	1	no	-4.453**	-2.953
Total unemployment rate	3	yes	-2.656	-3.547
Total unemployment rate	3	no	-0.929	-2.953
Change in total unemployment rate	5	yes	-4.774**	-3.561
Change in total unemployment rate	1	no	-4.821**	-2.953
Log total unemployment rate	5	yes	-4.224*	-3.556
Log total unemployment rate	3	no	-0.630	-2.953
Change in log total unemployment rate	1	yes	-5.225**	-3.551
Change in log total unemployment rate	1	no	-5.314**	-2.953
Accommodation ratio	0	yes	-2.104	-3.547
Accommodation ratio	0	no	-2.282	-2.953
Change in accommodation ratio	0	yes	-6.555**	-3.551
Change in accommodation ratio	0	no	-6.083**	-2.953
Log accommodation ratio	0	yes	-1.999	-3.547
Log accommodation ratio	0	no	-2.333	-2.953
Change in log accommodation ratio	3	yes	-4.365**	-3.551
Change in log accommodation ratio	0	no	-6.141**	-2.953
Programme participation rate	2	yes	-4.054*	-3.547
Programme participation rate	1	no	-2.188	-2.953
Change in programme participation rate	2	yes	-5.278**	-3.551
Change in programme participation rate	2	no	-5.327**	-2.953
Log programme participation rate	1	yes	-3.633*	-3.547
Log programme participation rate	1	no	-2.043	-2.953
Change in log programme participation rate	1	yes	-4.516**	-3.551
Change in log programme participation rate	1	no	-4.517**	-2.953

A4 Labour market programme participation

The rate of *ALMP* participation (as a fraction of the labour force) is described in *Figures* A16, A17 and A18, which contain information on the original series, its log transformation and its logarithmic change. The programmes include the major ones administered by the National Labour Market Board. Until 1984 these are *labour market training* and *relief work*. In 1984 *youth programmes* and *recruitment subsidies* are added. During the 1990s a vast number of new programmes were introduced. Of these, we have included *training replacement schemes*, *workplace introduction (API)* and *work experience schemes (ALU)*. *ALMP* participation is clearly upward trended over our sample period. Until the mid 1980s this primarily reflects a steady growth in training programmes, whereas the rapid growth in the early 1990s reflects the growth of participation in several programmes in the wake of the rapid increase in unemployment. The series is strongly serially correlated, as witnessed by both the correlogram and the spectral density. It is also far from normally distributed. The same basic observations also hold for the series in log form, although it is closer to being normally distributed. Differencing the log series removes most of the serial correlation, but the differenced series is bimodal and not even close to normality. Given the visible trend in the series, the preferred unit-root test includes both trend and constant in the test equation. The results in *Table* A4 then suggest that the programme participation rate (both in levels and logs) may be stationary around a deterministic trend.

Another way to look at the volume of *ALMPs* is to relate it to the sum of open unemployment and *ALMP* participation. This measure, often called the *accommodation ratio*, both captures the degree to which policy makers accommodate increases in the number of jobless persons through *ALMPs* and the likelihood for a job seeker to end up in a programme rather than in open unemployment. *ALMPs* are likely to affect wages through both these channels (Calmfors and Forslund, 1990; Calmfors and Lang, 1995). The accommodation ratio in level, log and logarithmic difference form is displayed in *Figures* A19, A20 and A21.

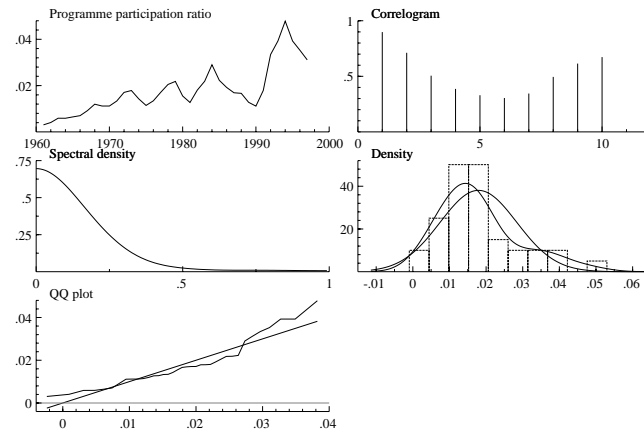

Figure A16: *ALMP* participation 1961–1997

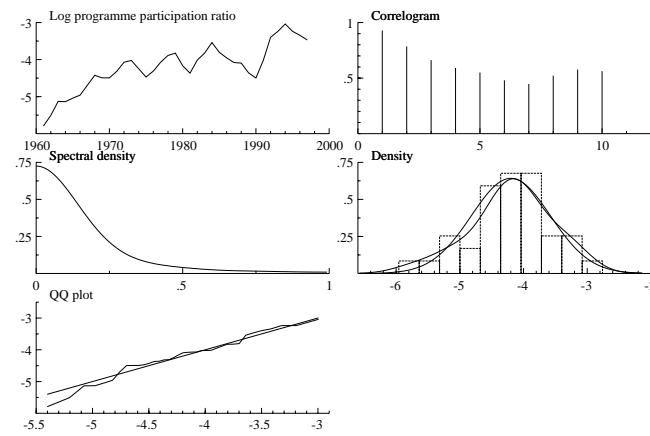

Figure A17: Log *ALMP* participation 1961–1997

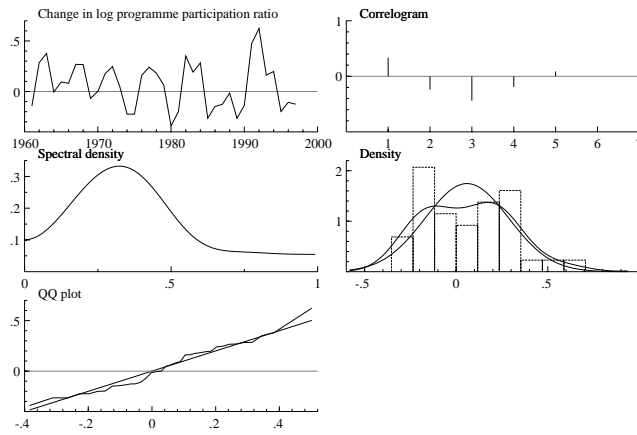

Figure A18: Change in log *ALMP* participation 1961–1997

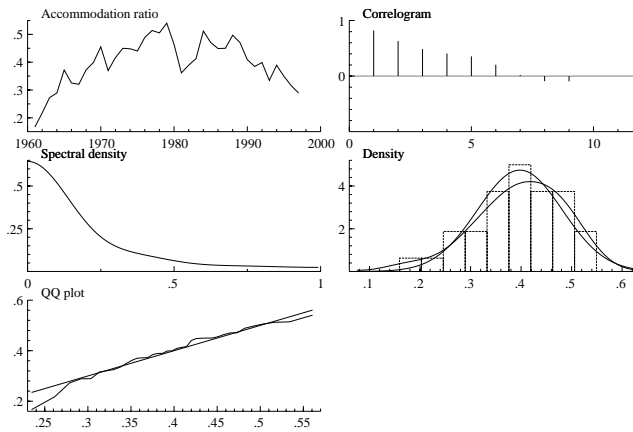

Figure A19: Accommodation ratio 1961–1997

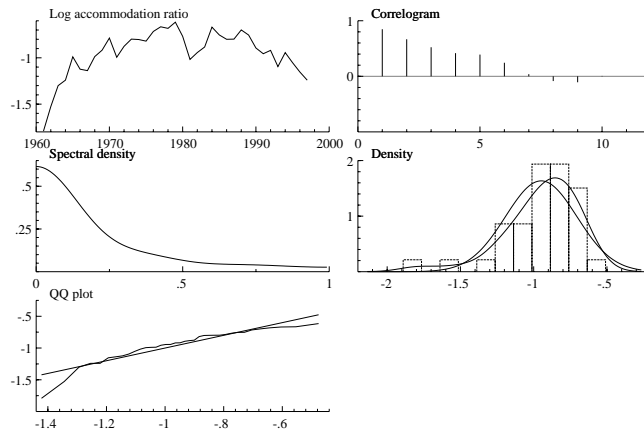

Figure A20: Log accommodation ratio 1961–1997

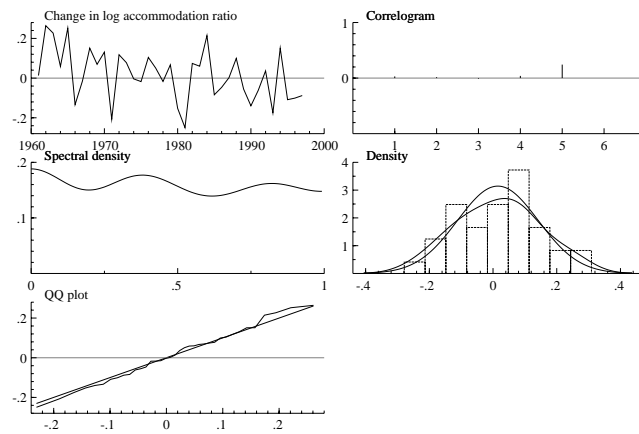

Figure A21: Change in log accommodation ratio 1961–1997

A5 Labour productivity

Labour productivity is measured as the value added at producer prices per hour worked (including hours worked by employers and self-employed) in the business sector. All data derive from the National Accounts statistics.

Productivity in the business sector exhibits extremely high serial correlation: the correlogram shows no visible drop during the period displayed in *Figure A22* and the spectrum has most of its mass concentrated at low frequency. The series is also clearly trended, with a tendency to slower growth after the first 15 years or thereabouts of the sample period. The distribution is somewhat skewed to the right and significantly non-normal (*Figure A22* and *Table A5*). Unit-root tests were performed both with constant and trend and with a constant only (*Table A6* below). In the test equations with both constant and trend included, a unit root was never rejected. In the displayed equations with only the constant, a unit root is rejected in the preferred equation. Thus, the conclusions regarding stationarity are not totally clear cut.

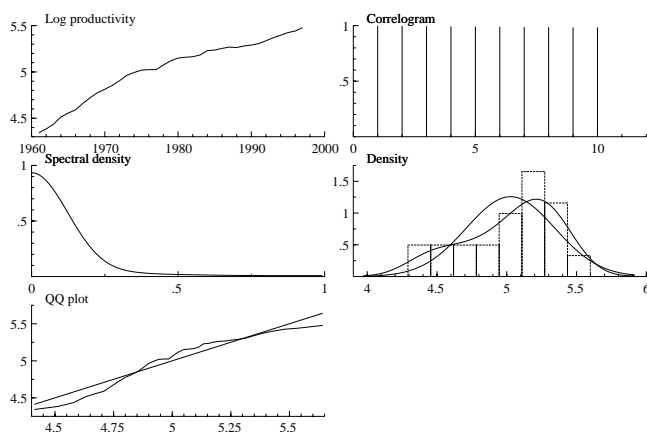

Figure A22: Log productivity in the business sector 1961–1997

Looking at the rate of change of productivity, we find much less of persistence, as witnessed both by the correlogram and the spectrum. The series also appears fairly normal (*Figure A23* and *Table A5*). Non-stationarity of the series is rejected in test equations both with and without a trend (*Table A6*). Results regarding the order of integration are, how-

Table A5: Normality tests labour productivity

Variable	Mean	Std. Devn.	Skewness	Normality χ^2
Log productivity	5.03	0.32	-0.64	8.02 [0.018]
Change in log productivity	0.032	0.020	0.19	0.65 [0.722]

ever, due to the results concerning the non-differenced series not conclusive.

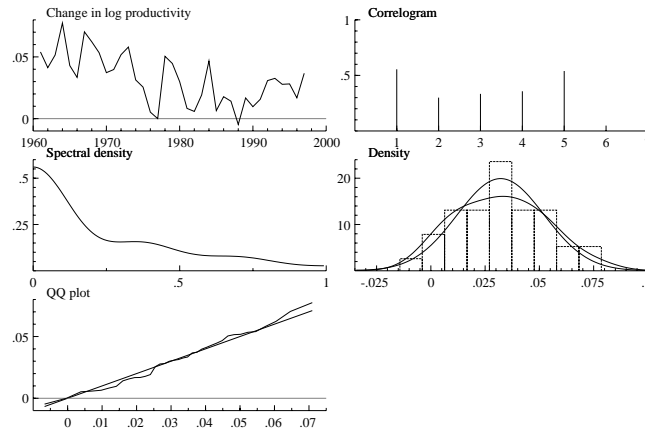

Figure A23: Change in log productivity in the business sector 1961–1997

Table A6: *ADF* tests for labour productivity

Variable	# lags	Trend included	t-statistic	Critical value
Log labour productivity	0	yes	-3.242	-3.547
Log labour productivity	2	no	-3.269*	-2.953
Change in log labour productivity	0	yes	-3.959*	-3.551
Change in log labour productivity	0	no	-3.690**	-2.953

A6 Taxes

The taxes in our data set are income taxes, payroll taxes and indirect taxes, i.e., the tax components of the tax-price wedge between product and consumption real wages. There are many possible ways to compute taxes, so we go into some detail to describe how ours have been derived.

A6.1 Income tax rates

As the Swedish tax system has been characterised by a rather high degree of progressivity over large parts of our sample period, we have computed average as well as marginal tax rates. This is a non-trivial task in several respects.

First, a decision has to be taken regarding the income at which tax rates are evaluated. Here we have chosen to use the average annual labour income in the business sector implied by the total wage sum (excluding payroll taxes) and the number of persons employed in the sector according to the National Accounts statistics. Our reason for this choice is consistency with our wage rate measures, which pertain to the average of the business sector.

Second, given our measure of annual income we have used information from the tax code and filled out income-tax return forms under the assumption that our hypothetical wage earner is living alone, has no capital income and has made only standard deductions.

This has produced a measure of an average income tax rate that is used in *Figure A24* below, which depicts the log of the income tax factor, $(1 - at)$, where at is the average tax rate. According to our measure, income taxes rose rapidly during the 1960s, then stayed fairly constant over the next 20 years. The tax reform of the early 1990s implied a large reduction in the tax rate, but the development since then has again produced a significantly higher average tax rate. The *ADF* tests reported in *Table A8* suggest that the average income tax rate is stationary over our sample period, although the series exhibits fairly high serial correlation as indicated by the correlogram and the spectral density in *Figure A24*.

We have also computed a point estimate of marginal income tax rates pertaining to the tax bracket at which the average tax rate is computed. This marginal tax rate is used to derive a measure of the progressivity, the coefficient of residual income progressivity, *RIP*, defined as the elasticity

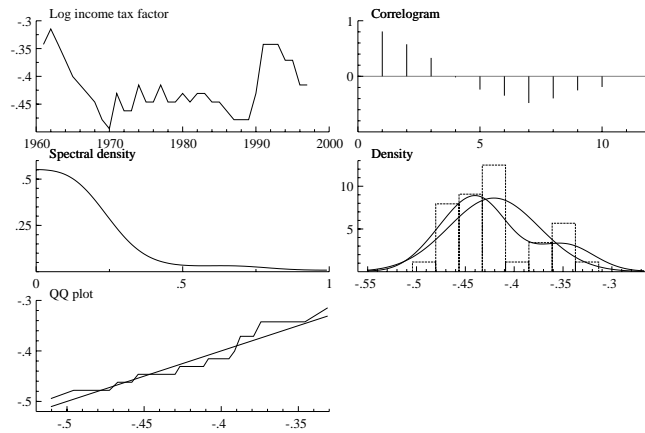

Figure A24: Log income tax factor 1961–1997

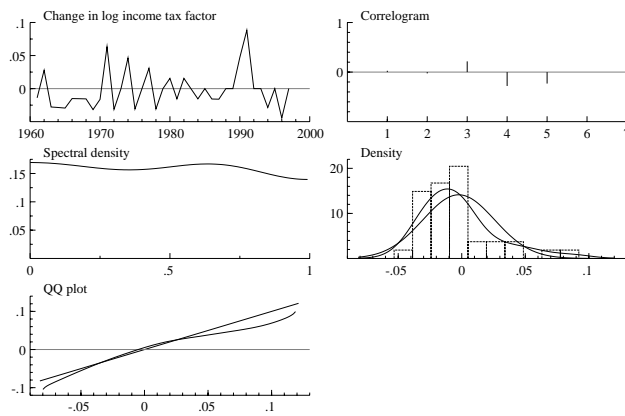

Figure A25: Change in log income tax factor 1961–1997

Table A7: Normality tests for tax variables

Variable	Mean	Std. Devn.	Skewness	Normality χ^2
Log tax wedge	0.753	0.157	-0.464	7.246**
Change in log tax wedge	0.011	0.030	-0.060	0.185
Log residual income progressivity	-0.269	0.134	0.346	1.101
Change in log residual income progressivity	0.006	0.087	0.971	20.275**
Log payroll tax factor	0.208	0.110	-0.349	23.306**
Change in log payroll tax factor	0.007	0.014	0.769	4.176
Log income tax factor	-0.421	0.046	0.669	7.320*
Change in log income tax factor	-0.002	0.028	1.299	12.784**
Log value added tax factor	0.124	0.040	0.070	10.241**
Change in log value added tax factor	0.002	0.013	1.338	13.626**

of post-tax income with respect to pre-tax income,

$$RIP \equiv \frac{\partial \ln(W - T(W))}{\partial \ln W} = \frac{1 - T'}{1 - T/W}, \quad (\text{A7})$$

where T is the total amount of taxes paid.

Thus, the measure equals the ratio between the marginal income tax rate and the average income tax rate. This is a rough measure of the cost (in terms of gross income increases, which affect employment) to a bargaining trade union of achieving net income increases for its members.⁸² The development and properties of tax progressivity are examined in *Figures* A26 and A27 and *Tables* A8 and A7.

Progressivity remained fairly unchanged from the beginning of our sample period until the early 1970s, when it increased rapidly for a number of years. This increase was halted in 1978, when a steady decrease in progressivity culminated in the 1991 tax reform, when most progressivity was removed. Since then, little has happened. The series is serially correlated, but almost all serial correlation is removed by first-differencing, as revealed by the correlograms in *Figures* A26 and A27. Normality is not rejected for the logged series, whereas the logarithmic change is significantly non-normal (cf. *Table* A7). The *ADF* tests in *Table* A8 do not reject a unit root in the (logged) levels series.

⁸²The measure is discussed and used in Lockwood and Manning (1993) and Holmlund and Kolm (1995).

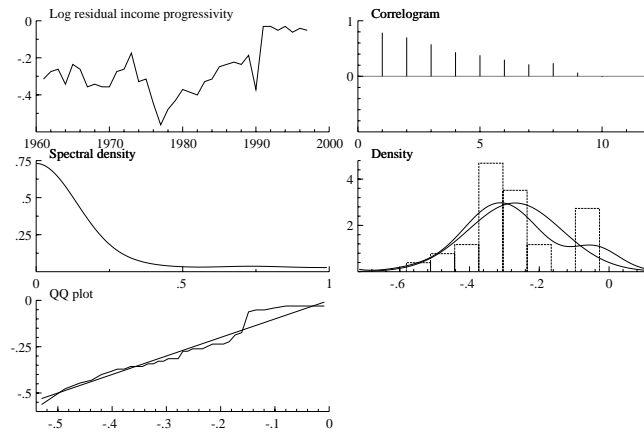

Figure A26: Log residual income progressivity 1961–1997

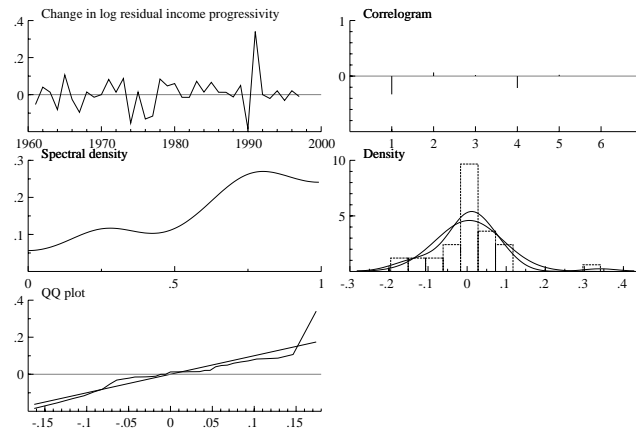

Figure A27: Change in log residual income progressivity 1961–1997

A6.2 Payroll taxes

The payroll taxes in our data set derive from the National Accounts statistics and are generated as the ratio between wage costs including and excluding employers' contributions to social security. Payroll taxes are regulated both by law and contract and differ between different categories of employees (basically, the significant difference is between white-collar workers and blue-collar workers). As we have no access to the composition of the workforce, we cannot use direct measures of payroll taxes. This is why we use the measure from the National Accounts statistics. The log and the logarithmic difference of the payroll tax factor are plotted in *figures* A28 and A29.

The payroll taxes stay fairly low over the 1960s and then increase rapidly during the 1970s. In the 1980s and 1990s, there is little change in the series, but there is a weak tendency for payroll taxes to go down since the beginning of the 1990s. We cannot reject non-stationarity for the log of payroll tax factor, whereas the logarithmic difference seems to be stationary. The log series is very far from normality, but it seems that the differenced series is much closer to the normal distribution.

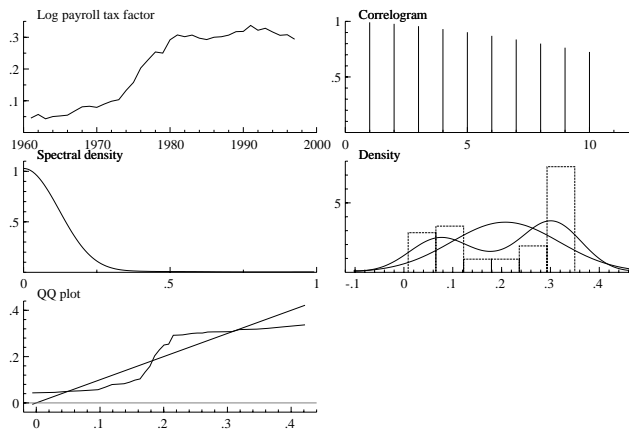

Figure A28: Log payroll tax factor 1961–1997

Table A8: *ADF* tests for tax variables

Variable	# lags	Trend included	t-statistic	Critical value
Log tax wedge	0	yes	-1.442	-3.547
Log tax wedge	0	no	-2.460	-2.953
Change in the log of the tax wedge	0	yes	-5.286**	-3.551
Change in the log of the tax wedge	0	no	-4.722**	-2.593
Log payroll tax factor	0	yes	0.022	-3.528
Log payroll tax factor	1	no	-1.191	-2.938
Change in log payroll tax factor	0	yes	-4.425**	-3.531
Change in log payroll tax factor	0	no	-4.272**	-2.94
Log income tax factor	3	yes	-3.567*	-3.547
Log income tax factor	3	no	-3.592*	-2.953
Change in log income tax factor	3	yes	-3.297	-3.551
Change in log income tax factor	3	no	-3.112*	-2.953
Log value-added tax factor	0	yes	-1.476	-3.528
Log value-added tax factor	0	no	-1.548	-2.938
Change in log value-added tax factor	0	yes	-5.934**	-3.531
Change in log value-added tax factor	0	no	-5.913**	-2.94
Log income tax progressivity factor	0	yes	-2.551	-3.547
Log income tax progressivity factor	0	no	-1.616	-2.953
Change in log income tax progressivity factor	0	yes	-7.901**	-3.551
Change in log income tax progressivity factor	0	no	-7.917**	-2.953

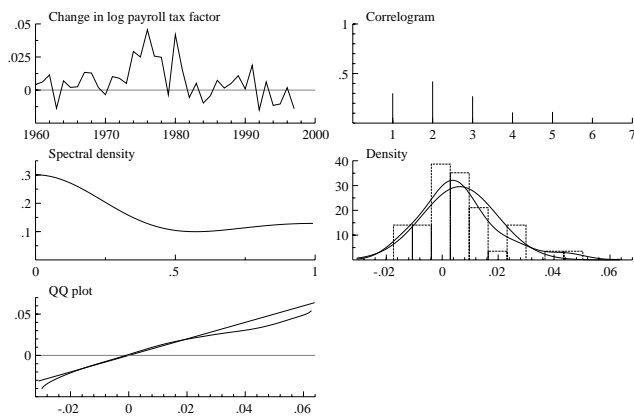

Figure A29: Change in log payroll tax factor 1961–1997

Table A9: *ADF* tests for relative import price and replacement ratio

Variable	# lags	Trend included	t-statistic	Critical value
Log relative import price	0	yes	-1.600	-3.528
Log relative import price	0	no	-1.484	-2.938
Change in log relative import price	0	yes	-5.276**	-3.531
Change in log relative import price	0	no	-5.351**	-2.94
Log replacement ratio	5	yes	-0.498	-3.556
Log replacement ratio	5	no	-1.828	-2.956
Change in log replacement ratio	2	yes	-6.630**	-3.551
Change in log replacement ratio	2	no	-6.287**	-2.953

A7 The relative price of imports

In *Section A2.2* above we saw that the wedge between the product real wage and the consumption real wage has two parts: one reflecting different tax rates and one reflecting the price of consumption relative to production. The latter, in turn, mirrors value added taxes and the relative price of imports to production. Our measure of the import price is the implicit price deflator for imports from the National Accounts statistics. The log and the logarithmic difference of the relative import price are plotted in *figures A30* and *A31*.

In a first phase ending in 1972, the relative price of imports falls more or less continuously. The first as well as the second oil price shocks coincide with sharp increases in import prices. Most likely this is further reinforced by a number of devaluations between 1976 and 1982 (the last two of which, in 1981 and 1982, amounted to around 25% taken together). The relative price then falls from around the mid 1980s to the early 1990s, once again a co-movement with oil prices. The float of the *Krona* in 1992 meant a sharp depreciation, which coincides with a rather rapid rise in import prices. The period thereafter has been rather calm.

The log of the import price seems to be non-stationary, whereas non-stationarity is rejected for the differenced series. Normality cannot be rejected for the logged series, whereas the logarithmic difference is significantly non-normal (*Table A10*).

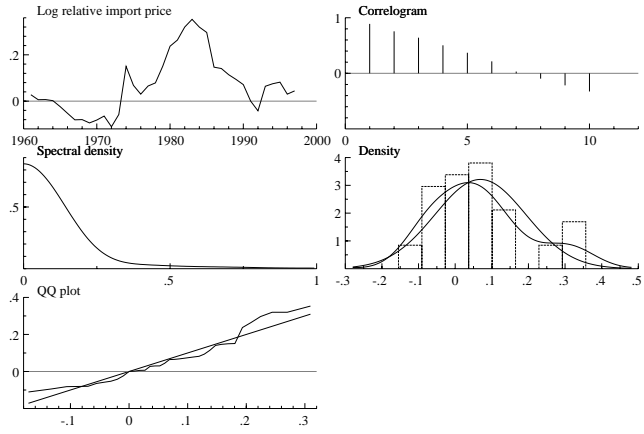

Figure A30: Log relative price of imports 1961–1997

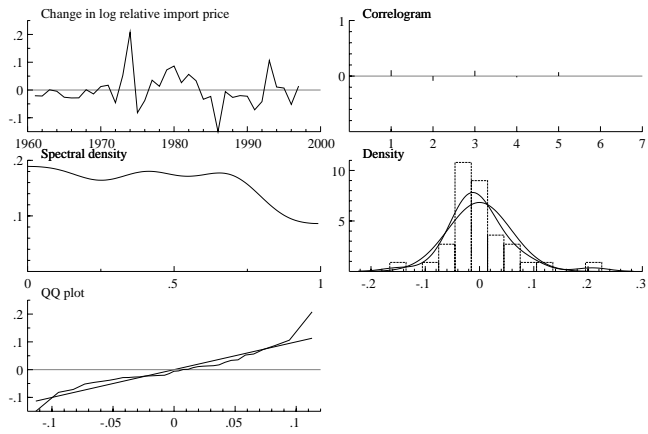

Figure A31: Change in log relative price of imports 1961–1997

Table A10: Normality tests for relative import price and the replacement ratio

Variable	Mean	Std. Devn.	Skewness	Normality χ^2
Log relative import price	0.075	0.119	0.611	4.267
Change in log relative import price	-0.004	0.056	1.065	14.861**
Log replacement ratio	-0.246	0.129	-1.180	11.397**
Change in log replacement ratio	0.003	0.126	1.784	15.187**

A8 The replacement rate in the unemployment insurance system

Our measure of the replacement rate in the unemployment insurance (*UI*) system is the ratio between the maximum daily before-tax compensation, turned into an annual figure by multiplying it by the relevant number of days, and the average annual before-tax labour income in the private sector. We use annual figures to take account of changes in the number of working days (and, thus, in the number of compensated days in a year). Before 1974, *UI* benefits were not taxed. We have computed a pre tax compensation by applying the average income tax rate to the before-tax figures.

We use the maximum daily compensation rather than, for instance, the regulated replacement rate. We do so because we are interested in the compensation for an average employee who risks losing the job. Then our measure is the relevant magnitude for the unions to care about in the wage negotiations, rather than the replacement rate for the average unemployed person, since the pool of unemployed includes a large fraction of non-unionised entrants into the labour market. Our measure is fairly comprehensive, but fails to take into account changes in the duration of benefit entitlements. For other purposes than ours, it also fails to take into account that there have been changes for those who are not members of any *UI* fund. The most important change in this respect is that a supplementary system, Cash Assistance, was created in 1974.

The development of the log of the replacement rate and its change are plotted in *figures* A32 and A33. The series exhibits a rising trend until the early 1990s. Since then the replacement rate has fallen considerably. During the earlier years of our sample period there are some rather big swings in our measure. To some extent they reflect our conversion of the post-tax compensation to a pre-tax measure: the income tax rate jumps around quite a lot during these years. The fall in the last part of our sample period reflects a combination of virtually unchanged maximum compensation and rising wages.

Both the logged series and the logarithmic difference are significantly non-normal according to the tests in *Table* A10. The tests in *Table* A9 indicate that the wedge behaves like an $I(1)$ variable.

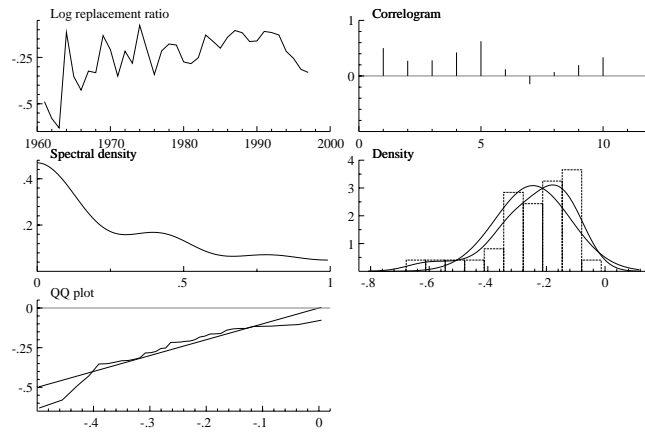

Figure A32: Log replacement rate in the unemployment insurance 1961–1997

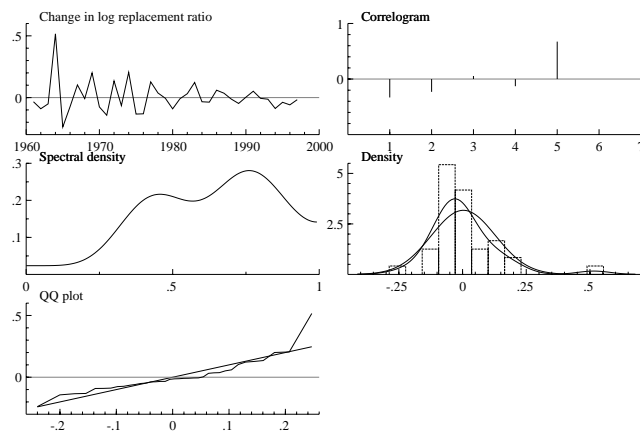

Figure A33: Change in log replacement rate in the unemployment insurance 1961–1997

B Estimating the model by *FIML* 1962–1997

In this appendix we reproduce some of the diagnostic (and other) output resulting from the estimation of the baseline system transformed to $I(0)$ space. All the tests are described in Doornik and Hendry (1997).

B1 The estimated equations

We begin with the parameter estimates from the four equations for the endogenous variables in *tables* B1, B2, B3 and B4 (the system tests indicated that unemployment and the tax wedge can be treated as weakly exogenous variables, so we do not model these).⁸³

Table B1: Equation 1 for $\Delta(w - q)$

Variable	Coefficient	Std.Error	t-value
$CI1_{t-1}$	0.156	0.053	2.917
$CI2_{t-1}$	-0.002	0.0002	-9.019
Constant	-0.501	0.053	-9.420
$\Delta\theta$	0.405	0.086	4.732
$\sigma = 0.016$			

Table B2: Equation 2 for $\Delta\gamma$

Variable	Coefficient	Std.Error	t-value
$CI3_{t-1}$	0.275	0.042	6.567
Constant	0.172	0.026	6.663
Δu	-0.353	0.059	-5.988
$\sigma = 0.080$			

B2 System diagnostics

An *LR* test of over-identifying restrictions gives $\chi^2(8) = 7.971[0.436]$, so the restrictions we impose are not rejected against the unrestricted reduced form.

The cross-equation residual correlations are reproduced in *Table* B5.

⁸³ $CI1$, $CI2$ and $CI3$ are the three cointegrating combinations.

Table B3: Equation 3 for $\Delta(p_I - p_p)$

Variable	Coefficient	Std.Error	t-value
$CI1_{t-1}$	-0.110	0.196	-0.561
$CI2_{t-1}$	0.002	0.001	2.377
Constant	0.543	0.210	2.583
$\Delta\theta$	-0.496	0.300	-1.654
$\sigma = 0.056$			

Table B4: Equation 4 for $\Delta\rho$

Variable	Coefficient	Std.Error	t-value
$CI1_{t-1}$	2.299	0.318	7.231
$CI3_{t-1}$	-0.282	0.052	-5.388
Constant	0.589	0.089	6.637
Δu	-0.107	0.063	-1.699
$\Delta\theta$	-1.073	0.502	-2.136
$\sigma = 0.087$			

Table B5: Correlation of residuals

	$\Delta(w - q)$	$\Delta\gamma$	$\Delta(p_I - p_p)$	$\Delta\rho$
$\Delta(w - q)$	1.00			
$\Delta\gamma$	0.065	1.00		
$\Delta(p_I - p_p)$	0.390	-0.210	1.00	
$\Delta\rho$	-0.499	0.056	-0.183	1.00

Testing for vector error autocorrelation from lags 1 to 5 gives $\chi^2(80) = 89.97[0.209]$ and in F-form(80,37) = 0.869 [0.704]. Thus, there is no serious autocorrelation problem at the systems level.

A vector normality test gives $\chi^2(8) = 24.417[0.002]**$. Thus, as pointed out in the main text, there are strong indications of non-normal residuals.

Testing for vector heteroscedasticity using squares gives $\chi^2(100) = 101.08[0.451]$ and in F-form(100,97) = 0.783 [0.887]. Testing for vector heteroscedasticity using squares and cross-products gives $\chi^2(200) = 209.18[0.314]$ and in F-form(200,40) = 0.684 [0.952]. Thus, there are no indications of heteroskedasticity problems at the systems level.

B3 Single equation diagnostics

Next, we look at the single equations in the model. We begin by investigating residual autocorrelation. Autocorrelation coefficients and an *LM* test are reported in *Table B6*. The only equation with some slight problem is the equation for the wage share, which marginally passes the test.

Table B6: Single equation autocorrelation statistics

Equation	lag1	lag2	lag3	lag4	lag5	F	p-value
$\Delta(w - q)$	0.286	-0.006	0.477	-0.407	0.134	2.063	0.104
$\Delta\gamma$	0.196	0.018	-0.346	0.005	-0.116	1.222	0.328
$\Delta(p_I - p_p)$	-0.028	-0.070	0.136	-0.004	-0.050	0.806	0.556
$\Delta\rho$	-0.074	-0.158	0.144	-0.058	0.274	0.595	0.704

Next, we look at residual normality in the single equations in *Table B7*. All equations except the one for the relative import price pass the test for residual normality. The latter equation, on the other hand, is not even close to passing the test. The significant test at the systems level thus mainly reflects problems in this equation.

Table B7: Single equation normality tests

Equation	χ^2	p-value
$\Delta(w - q)$	0.369	0.832
$\Delta\gamma$	3.531	0.171
$\Delta(p_I - p_p)$	16.837	0.0002
$\Delta\rho$	3.639	0.162

As there are no indications at all of ARCH problems in any of the equations, we do not report these statistics.

Finally, as regards heteroskedasticity, both tests using the squares of the regressors and tests using cross-products of the regressors in addition to their squares indicate heteroskedasticity in the equation for the replacement rate (p-values 0.002 and 0.006), whereas the equation for the relative import price only passes the tests marginally (p-values 0.108 and 0.192).