

Daun, Marian; Fockel, Markus; Holtmann, Jörg; Tenbergen, Bastian

Research Report

Goal-scenario-oriented requirements engineering for functional decomposition with bidirectional transformation to controlled natural language: Case study "body control module"

ICB-Research Report, No. 55

Provided in Cooperation with:

University Duisburg-Essen, Institute for Computer Science and Business Information Systems (ICB)

Suggested Citation: Daun, Marian; Fockel, Markus; Holtmann, Jörg; Tenbergen, Bastian (2013) : Goal-scenario-oriented requirements engineering for functional decomposition with bidirectional transformation to controlled natural language: Case study "body control module", ICB-Research Report, No. 55, Universität Duisburg-Essen, Institut für Informatik und Wirtschaftsinformatik (ICB), Essen

This Version is available at:

<https://hdl.handle.net/10419/75284>

Standard-Nutzungsbedingungen:

Die Dokumente auf EconStor dürfen zu eigenen wissenschaftlichen Zwecken und zum Privatgebrauch gespeichert und kopiert werden.

Sie dürfen die Dokumente nicht für öffentliche oder kommerzielle Zwecke vervielfältigen, öffentlich ausstellen, öffentlich zugänglich machen, vertreiben oder anderweitig nutzen.

Sofern die Verfasser die Dokumente unter Open-Content-Lizenzen (insbesondere CC-Lizenzen) zur Verfügung gestellt haben sollten, gelten abweichend von diesen Nutzungsbedingungen die in der dort genannten Lizenz gewährten Nutzungsrechte.

Terms of use:

Documents in EconStor may be saved and copied for your personal and scholarly purposes.

You are not to copy documents for public or commercial purposes, to exhibit the documents publicly, to make them publicly available on the internet, or to distribute or otherwise use the documents in public.

If the documents have been made available under an Open Content Licence (especially Creative Commons Licences), you may exercise further usage rights as specified in the indicated licence.



ICB

Institut für Informatik und
Wirtschaftsinformatik

Marian Daun, Markus Fockel,
Jörg Holtmann, Bastian Tenbergen



Goal-Scenario-Oriented Requirements Engineering for Functional Decomposition with Bidirectional Transfor- mation to Controlled Natural Language

ICB-RESEARCH REPORT

Case Study "Body Control Module"

Die Forschungsberichte des Instituts für Informatik und Wirtschaftsinformatik dienen der Darstellung vorläufiger Ergebnisse, die i. d. R. noch für spätere Veröffentlichungen überarbeitet werden. Die Autoren sind deshalb für kritische Hinweise dankbar.

The ICB Research Reports comprise preliminary results which will usually be revised for subsequent publications. Critical comments would be appreciated by the authors.

Alle Rechte vorbehalten. Insbesondere die der Übersetzung, des Nachdruckes, des Vortrags, der Entnahme von Abbildungen und Tabellen – auch bei nur auszugsweiser Verwertung.

All rights reserved. No part of this report may be reproduced by any means, or translated.

Authors' Addresses:

Marian Daun
Bastian Tenbergen
paluno – The Ruhr Institute for Software
Technology
University of Duisburg-Essen
Gerlingstrasse 16
D-45127 Essen, Germany

Markus Fockel
Jörg Holtmann
Project Group Mechatronic Systems
Design
Fraunhofer Institute for Production
Technology IPT
Zukunftsmeile 1
33102 Paderborn, Germany

ICB Research Reports

Edited by:

Prof. Dr. Heimo Adelsberger
Prof. Dr. Frederik Ahlemann
Prof. Dr. Klaus Echtele
Prof. Dr. Stefan Eicker
Prof. Dr. Ulrich Frank
Prof. Dr. Michael Goedicke
Prof. Dr. Volker Gruhn
PD Dr. Christina Klüver
Prof. Dr. Tobias Kollmann
Prof. Dr. Klaus Pohl
Prof. Dr. Erwin P. Rathgeb
Prof. Dr. Rainer Unland
Prof. Dr. Stephan Zelewski

Contact:

Institut für Informatik und
Wirtschaftsinformatik (ICB)
Universität Duisburg-Essen
Universitätsstr. 9
45141 Essen

Tel.: 0201-183-4041

Fax: 0201-183-4011

Email: icb@uni-duisburg-essen.de

ISSN 1860-2770 (Print)
ISSN 1866-5101 (Online)

Abstract

Requirements for embedded systems are mainly documented using natural language. This is due to the fact that natural language does not require special nomenclature knowledge and is accepted as the basis for contractual agreements. However, purely natural-language-based requirements engineering (RE) is often error-prone, potentially ambiguous, and does not foster traceability and hence requires tedious manual reviews and analyses. Model-based requirements engineering is often considered a possible solution as models enhance traceability, aid in stakeholder communication, and foster automatic model analysis and model checking. However, model-based requirements engineering is only slowly adopted in the industry, partly because no clear guidelines to their application exist, particularly in legally binding documents. In order to combine the advantages of model-based requirements engineering with the convenience of natural-language-based requirements engineering, we developed a combined RE approach that relies on both a controlled natural language (i.e., a natural language that is restricted in its expressiveness) as well as requirements models and defines a structured interface between both specification paradigms. The purpose of this document is to report on the application of the combined approach in an industrial case study from the automotive industry: a body control module. A body control module is an electronic control unit (ECU) that centralizes the control of body and comfort functions provided by multiple other ECUs distributed in a vehicle. The case study illustrates how controlled natural language as well as requirements models can be used in order to specify solution-neutral goal and scenario models as well as functional requirements of a body control module across multiple layers of abstraction.

Table of Content

1	INTRODUCTION	1
2	RELATED WORK.....	4
2.1	AUTOMATIC GENERATION OF MODELS FROM NL-REQUIREMENTS	5
2.2	GENERATING NL-REQUIREMENTS SPECIFICATIONS FROM MODELS	6
2.3	CONCLUSIONS FROM THE RELATED WORK.....	7
3	A CONTROLLED-NATURAL-LANGUAGE-BASED REQUIREMENTS ENGINEERING APPROACH.....	8
3.1	METHODOLOGY	9
3.2	TEXTUAL REQUIREMENT PATTERNS.....	10
4	A MODEL-BASED REQUIREMENTS ENGINEERING APPROACH	14
4.1	THE ABSTRACTION LAYER MODEL	14
4.2	THE ARTIFACT MODEL	16
5	COMBINING CONTROLLED-NATURAL-LANGUAGE-BASED AND MODEL-BASED REQUIREMENTS ENGINEERING.....	20
5.1	METHODOLOGY ADAPTATION	20
5.2	COMBINED PROCESS MODEL	20
6	CASE STUDY: AUTOMOTIVE BODY CONTROL MODULE.....	25
6.1	COMPLETE SYSTEM LAYER.....	25
6.2	SUBSYSTEM LAYER	32
6.3	FUNCTION LAYER.....	40
7	CONCLUSIONS AND FUTURE WORK.....	46
	REFERENCES	47

Table of figures

FIGURE 1: FUNCTION HIERARCHY DESCRIBED USING REQUIREMENT PATTERNS (BASED ON [HOLTMANN ET AL. 2011B])	9
FIGURE 2: FROM REQUIREMENTS TO ANALYSIS MODEL (BASED ON [FOCKEL ET AL. 2012A])	13
FIGURE 3: THE REQUIREMENTS VIEW ABSTRACTION LAYER HIERARCHY	15
FIGURE 4: THE ARTIFACT MODEL OF THE MB-RE APPROACH.....	17
FIGURE 5: PROCESS FOR THE INTEGRATED METHODOLOGY	21
FIGURE 6: ENVIRONMENT OF THE <i>BODYCONTROLMODULE</i> ON COMPLETE SYSTEM LAYER.....	25
FIGURE 7: GOALS ON COMPLETE SYSTEM LAYER.....	27
FIGURE 8: USE CASES ON COMPLETE SYSTEM LAYER	28
FIGURE 9: SCENARIO <i>INDICATE LEFT</i> ON COMPLETE SYSTEM LAYER.....	29
FIGURE 10: SCENARIO <i>EMERGENCY BRAKE LIGHT CONTROLLING</i> ON COMPLETE SYSTEM LAYER.....	30
FIGURE 11: SCENARIO <i>HANDLE LEFT LAMP DEFECT</i> ON THE COMPLETE SYSTEM LAYER	30
FIGURE 12: FUNCTION HIERARCHY ON THE COMPLETE SYSTEM LAYER.....	31
FIGURE 13: INITIAL FUNCTION HIERARCHY ON THE SUBSYSTEM LAYER	32
FIGURE 14: ENVIRONMENT OF THE SUBSYSTEM <i>CONTROLTURN SIGNALS</i> ON THE SUBSYSTEM LAYER.....	33
FIGURE 15: ENVIRONMENT OF THE SUBSYSTEM <i>CONTROLBRAKE LIGHT</i> ON THE SUBSYSTEM LAYER.....	34
FIGURE 16: ENVIRONMENT OF THE SUBSYSTEM <i>HANDLELAMP DEFECT</i> ON THE SUBSYSTEM LAYER.....	35
FIGURE 17: SCENARIO <i>EMERGENCY BRAKE LIGHT CONTROLLING</i> ON THE SUBSYSTEM LAYER	36
FIGURE 18: FUNCTIONAL INTERACTION BETWEEN THE SUBSYSTEMS ON THE SUBSYSTEM LAYER.....	37
FIGURE 19: FINAL FUNCTIONAL HIERARCHY ON THE SUBSYSTEM LAYER.....	37
FIGURE 20: INITIAL FUNCTION HIERARCHY ON THE FUNCTION LAYER	39
FIGURE 21: ENVIRONMENT OF THE FUNCTION <i>SWITCHHAZARD LIGHTS</i> ON THE FUNCTION LAYER	40
FIGURE 22: ENVIRONMENT OF THE FUNCTION <i>SIGNALIZEEMERGENCYBRAKE</i> ON THE FUNCTION LAYER.....	41
FIGURE 23: SCENARIO <i>EMERGENCY BRAKE LIGHT CONTROLLING</i> ON FUNCTION LAYER.....	41
FIGURE 24: FINAL FUNCTION HIERARCHY	43
FIGURE 25: TIMING REQUIREMENT IN MODEL-BASED REPRESENTATION	44

1 Introduction

Literature shows that natural language is the most common documentation format for requirements specifications (e.g., [Juristo et al. 2002, Pretschner et al. 2007]). Partly, this is due to the fact that requirements often become the foundation for contractual agreements [Sikora et al. 2011], for example, between original equipment manufacturers (OEMs) and suppliers [Jersak et al. 2003]. Using natural language has advantages for the requirements engineering of embedded systems: on the one hand, it does not require stakeholders and developers to become familiar with special documentation formats (e.g., formal models) and is therefore easy to understand [Balzert 2009]. On the other hand, it typically does not mandate dedicated documentation tools. However, there are a number of disadvantages using natural language in requirements specifications: since it is inherently ambiguous, it can be interpreted in different ways by the stakeholders (e.g., [Balzert 2009, Pohl 2010]), and it cannot be easily processed using automated tools [Yue et al. 2011]. In addition, it requires manual traceability management [Gotel and Finkelstein 1994] and the sheer volume of requirements in some development projects impairs requirements validation significantly [Flynn and Warhurst 1994]. One approach to tackle the problem of the inherent ambiguity of natural language is to restrict its expressiveness by only allowing certain formulations, phrases, and a restricted vocabulary. Such a restricted language is called a *controlled natural language (CNL)* [Huijsen 1998a, Huisen 1998b, Schwitter 2010].

Using requirements models has been suggested as alleviation for the inherent problems with natural language-based requirements specification. Using models to document requirements is beneficial for communication among stakeholders [Pohl 2010]. In addition, models can help to manage the complexity of the system [Neill and Laplante 2003] and can be processed automatically. However, model-based approaches are only hesitantly adopted by the industry partly due to the fact that there is little guidance available on when and how to use models during the engineering of embedded systems [Sikora et al. 2012]. While some approaches such as the SPES Modeling Framework [Broy et al. 2012] have been developed in order to address this problem, such approaches do not take into account that models are not considered as a suitable foundation for contractual agreements [Sikora et al. 2011].

Furthermore, it is sensible for the development process to develop the system architecture not only based on the requirements specification, but in step with it [Nuseibeh 2001], ideally based on a functional hierarchy, which documents required system functions [Schäuffele and Zurawka 2003, Gausemeier et al. 2009]. This way, the architecture can be based on the functional hierarchy, which fosters the requirements to be accurately reflected in the architecture [Fockel et al. 2012a]. While some approaches exist which tackle the integration of requirements and architecture, these approaches either consider a coarse development process (e.g., [Nuseibeh 2001]), are solely model-based (e.g., [Pohl and Sikora 2007]), or solely based on (controlled) natural language (e.g., [Holtmann 2010, Holtmann et al. 2011a,

Holtmann et al. 2011b]). The integration of model-based and natural-language-based requirements engineering for the purpose of fostering the co-development of requirements and functionality has thus far not been tackled by existing literature.

The purpose of this document is to show the application of an integrated requirements engineering approach in an industrial case study. This RE approach makes use of both controlled natural language and requirements models in order to combine the advantages of both documentation formats and in order to allow for the co-development of a function hierarchy and system requirements. The integrated requirements engineering approach combines the pattern-based, controlled natural language requirements engineering approach (CNL-RE approach) presented in [Holtmann et al. 2011b] with a model-based requirements engineering approach (MB-RE approach).

The CNL-RE approach provides the ability to specify requirements such that they can be used as a contractual basis between suppliers and OEMs. In addition, by using a strict grammar, it prevents ambiguities for the purpose of conducting automated analyses [Holtmann 2010] and allows structuring functionalities hierarchically.

The MB-RE approach is a seamless model-based approach to document requirements, beginning with the system environment and coarse, solution-neutral requirements to solution-oriented functional requirements. It relies heavily on a goal- and scenario-oriented process and provides a number of specialized requirements model types which allow for traceability between one another.

By combining the approaches, requirements can be elicited, agreed upon, and documented both based on models and textually. The requirements engineer can switch between both representations as fits best. For instance, the textual representation can be used for document-oriented reviews or a contractual agreement with the customer, and the model-based representation can be used to derive the system architecture as the next step in a model-based development process.

The industrial case study presents a *Body Control Module (BCM)* from the automotive domain. A BCM is an embedded system that constitutes a new paradigm in managing the increasing number and complexity of electronic control units (ECUs) in the passenger compartment of modern vehicles. The purpose of the BCM is to dispatch control commands, relay sensor information, and manage data exchange between many different control units, for example, ECUs for the power door locks, the turn signals, etc. In essence, a BCM is a control unit for control units. The advantage of such a paradigm is that the interconnectivity between the various control units is decreased, as every control unit only requires a connection to the BCM, thereby leading to a reduction in the size of the cable tree inside the vehicle. For example, rather than having to connect all four turn signals with one another to ensure synchronous hazard flashing, the turn signals only need to be connected to the BCM which in turn synchronizes them. On the other hand, this means that the BCM must be able

to handle a large variety of different functions, which all have to be accounted for during requirements engineering. That is, it must not only be able to control functions of the individual attached systems, but it must also be able to control the attached systems in conjunction with one another.

This paper is structured as follows: Section 2 illustrates the related work regarding the integration of model-based and natural language-based requirements engineering approaches. The following sections introduce the controlled-natural-language-based and the model-based requirements engineering approaches, which were merged to an integrated approach, respectively (Sections 3 and 4). Section 5 introduces the integrated approach before Section 6 shows the application of the integrated approach on the automotive case study BCM. Section 7 summarizes this document and provides an outlook on future work.

2 Related Work

The relevant literature on the integration of model-based and natural-language-based requirements engineering covers two main research areas.

On the one hand, there exist approaches concerning the manual, semi-, or even fully automated creation of models from natural language requirements. A systematic review of such approaches has been conducted by Yue et al. [Yue et al. 2011]. The authors motivate the importance of this type of approach by means of the lifecycle of the Model Driven Architecture (MDA) [OMG 2003]. One basic principle of the MDA is to automatically create a platform-specific model from a platform-independent model by means of model transformations. In contrast to that, a transformation from requirements to an analysis model is not covered by the MDA lifecycle. Yue et al. assume that this is caused by the typical natural language representation of requirements that complicates automated techniques for processing them. However, they argue that a (semi-)automated transformation approach from requirements to analysis models would fill an important gap in the MDA software development life cycle. Furthermore, Yue et al. state that such approaches could help to (semi-)automate the establishment and maintenance of traceability between requirements and analysis models as well as to the subsequent design models and the implementation.

On the other hand, other approaches focus on creating textual requirements specifications from graphical models in a manual, semi-, or full-automatic manner. A systematic literature review of such approaches has been presented in [Nicolás and Toval 2009]. As illustrated in Section 1, requirements models and natural language requirements both have benefits and disadvantages for the development process. According to [Goldsmith 2004], models are appropriate for representing requirements, but natural language requirements foster proper requirements validation. In addition, while models are in general more expressive and more precise, natural language is used for the contract with the customer and eases the requirements management [Sikora et al. 2011]. Hence, it has been argued that the combination of model-based and natural-language-based requirements improves the requirements engineering process as it may allow incorporating benefits from both documentation forms [Davis 2005]. In particular, the main benefit of this combination is that it reduces the effort for writing the requirements, improves the completeness of the requirements specifications, and automatically establishes and maintains traceability between textual requirements and requirements models [Nicolás and Toval 2009], as is required by many standards (e.g., [IEEE 830], [ISO 26262]) and maturity models (e.g., Automotive SPICE [AutomotiveSIG 2010]).

Until now, there are no approaches that support the bidirectional and hence tight interrelation of model-based and natural language-based requirements engineering in a semi- or fully automatic way. This is also indicated by the above mentioned systematic

literature surveys, which only cover one direction (i.e., from natural language requirements to models and vice versa). Moreover, we conducted a systematic literature review with particular focus on such articles featuring semi- or fully automated approaches. In the following, our findings are summarized with regard to the targeted use of natural language as well as models for eliciting, documenting, reconciling, and validating requirements.

We present related approaches on (semi-)automatically generating models from natural-language-based in the first subsection and approaches that transform model-based requirements into natural language in the second subsection. We conclude in the last subsection.

2.1 Automatic generation of models from NL-requirements

Illieva and Ormandjieva [Illieva and Ormandjieva 2006] describe a method for automatically eliciting UML models from natural language requirements. The authors present a formalism which is used to create three models from textual requirements: the Use Case Path Model, the Hybrid Activity Diagram, and the Domain Model. These models are abstractions from the information in natural language requirements and serve as a basis for deriving various UML models.

Ambriola and Gervasi introduce an environment for analyzing and transforming natural language requirements [Ambiola and Gervasi 1997; Ambiola and Gervasi 2006]. This environment can parse natural language requirements and transform them into various models (e.g., ER diagrams, UML models, state diagrams) using an expert system. Natural language requirements are first transformed into parse trees and then saved in a common tuple space. This tuple space contains the basic-knowledge about the textual requirements. Using various transformation operations, various models can be derived automatically from the tuple space. The created models in turn can be checked, tested, and validated using various criteria.

Deeptimahanti and Babar or Sanyal [Deeptimahanti and Barbar 2009; Deeptimahanti and Sanyal 2011] describe the automatic generation of UML models from natural language requirements as well, using a tool. The tool possesses three generators to generate Use Case diagrams, conceptual models, and code, respectively.

Harmain and Gaizauskas [Harmain and Gaizauskas 2000; Harmain and Gaizauskas 2003] introduce a CASE tool, which is supposed to facilitate the requirements engineering analysis process. The tool generates an initial UML class diagram from natural language requirements documents. This UML class diagram represents the object-classes and their relationships as mentioned in the requirements documents, and can be translated directly into a graphic representation for further editing.

Kiyavitskaya and Zannone describe in [Kiyavitskaya and Zannone 2008] a method for facilitating the Secure Tropos methodology during the requirements elicitation phase. A tool,

which is supporting the methodology, aims at translating natural language requirements in semi-structured specifications based on the SI* modeling framework – an extension of the i*-language for goal-modeling.

Leonid Kof describes a method for transforming natural language descriptions of interaction sequences into automata or MSCs [Kof 2009]. This method is based on what Kof refers to as *Discourse Context Modeling* for adding missing information to the natural language specification. Furthermore, Kof describes in [Kof 2010] an interactive, adaptive CASE-tool for facilitating processing natural language requirements. In this approach, a user marks a sequence of words in the present text and selects a model element to which those properties (e.g., the element's name) are assigned that can be found in the text sequence. This creates links between text sequences and model elements. These links serve as training sets, which can be used to foster automatic extraction of model elements and relations.

In [Mich et al. 2002], the authors present a CASE-tool prototype for analyzing requirements, based on processing natural language documents. The tool supports the automatic identification of classes and the corresponding associations from textual requirements documents and generates an abstract model. Similar to [Kof 2010], the model elements are connected to their textual sources by introducing traceability links.

2.2 Generating NL-requirements specifications from models

In [Drusinsky 2008], a process is described that translates functional and behavioral models such as UML activity diagrams and MSCs into natural language requirements. This approach was developed to facilitate the increasing popularity of UML during development and to be able to express those modeled requirements in natural language form. Similarly, Meziane et al. introduce an approach in [Meziane et al. 2008] that derives natural language requirements specifications from UML class diagrams. For this purpose, a system of rules is used in conjunction with a linguistic ontology in order to express the diagram's components. The goal is to document the current state of the system under development in a format that is understandable for all stakeholders.

Lu et al. [Lu et al. 2007; Lu et al. 2008b; Lu et al. 2008a] present a model-based, object-oriented approach for eliciting and managing requirements. For this purpose, a requirements management tool is introduced, which facilitates the integration of object-oriented concepts and model-based requirements engineering. The principle of "modeling requirements documents" is meant to improve completeness, consistency, and traceability as well as integration with artifacts from other phases of the development. In addition, typical problems of ambiguity and inconsistency in natural language documentation of requirements can be reduced by presenting the knowledge of the pseudo-domain in an explicit, well-defined requirements model.

2.3 Conclusions from the Related Work

As can be seen from the literature regarding text-to-model transformation, most approaches generate UML models like Use Case diagrams or class diagrams, either directly or via several intermediate transformations. These various approaches are typically meant to dissolve the inherent ambiguity in natural-language-based requirements. On the other hand, the approaches focusing on model-to-text transformation primarily aim at facilitating the communication with stakeholders who have no experience with models. The respective authors of the approaches commonly agree that such methods offer good support for the elicitation, documentation, reconciliation, and validation processes in requirements engineering, and, moreover, they make possible to save much time and much costs. In essence, each of the approaches presented above allow the developer to benefit from the transition in certain development scenarios and in specific points during development.

Yet, it can be seen that no approach specifically regards the co-development of natural language requirements and requirements models. While the approaches presented above focus on the explicit transition either from models to text or from text to models, no approach defines a development process that strategically incorporates the transition from models to text and vice versa in order to make the benefits of both requirements models and natural language requirements available throughout development.

A technical prerequisite for such a development or requirements engineering process is the possibility of synchronization between natural language and models. It was argued in [Nicolás and Toval 2009] that such a "synchronization could be useful in an iterative and incremental software process", thereby fostering validation, as validation can be "carried out directly on the widely understandable generated textual requirements, which could be changed to make the related models evolve automatically through traceability relationships" [Nicolás and Toval 2009].

3 A Controlled-Natural-Language-based Requirements Engineering Approach¹

In previous work, we conceived a seamless, model-based design methodology for automotive systems with focus on suppliers [Fockel et al. 2012a; Fockel et al. 2012b; Holtmann et al. 2011a]. This automotive-specific design methodology is concerned with requirements engineering and focuses on the formulation of requirements using natural language, the validation of requirements and the transition to model-based design.

Our development methodology starts with so-called *customer requirements* [AutomotiveSIG 2010] that typically are specified informally and are made available to the supplier by an original equipment manufacturer (OEM). These customer requirements specify the high-level functionality of the system to be developed. Based on the customer requirements and technical implementation knowledge, the supplier specifies more detailed *system requirements* [AutomotiveSIG 2010], which propose a possible implementation of the required system functionality.

Since requirements models are not necessarily understood by all stakeholders, their use is not feasible in many development scenarios as contractual basis or to satisfy standards. This is especially true for the automotive sector, which is characterized by the collaboration between OEMs and many suppliers. Consequently, requirements specifications in the embedded or automotive domain are typically formulated by means of natural language [Sikora et al. 2012]. This complicates the automatic processing of the specifications. Thus, requirements validation and the transition to model-based design have to be performed manually, which is extensive and error-prone.

To overcome this problem, we use a Controlled Natural Language (CNL) approach for the specification of system requirements in the automotive domain [Holtmann et al. 2011b]. The CNL restricts the expressiveness of natural language and disambiguates it, enabling automatic processing of the requirements while having natural language requirements understandable for all stakeholders at the same time. We extended a CNL for the specification of functional system requirements, which is already successfully used in the automotive industry [Kapeller and Krause 2006].

¹This chapter bases on the previously published work ([Fockel et al. 2012a; Fockel et al. 2012b; Holtmann 2010; Holtmann et al. 2011a; Holtmann et al. 2011b]).

3.1 Methodology

Requirement patterns are a means to describe the functionality of the system under development (SUD), as sketched in Figure 1. The patterns allow refining the overall system functionality across systems (i.e., a grouping of functionality) to atomic functions across several abstraction layers. Besides the different functions, also the dependencies between them are of interest. To identify the dependencies, the input and output data required and provided by the different functions are analyzed and described by using the CNL in terms of signals. The approach is similar to the Structured Analysis as presented in [Ross and Schoman 1977; DeMarco 1979], for example. By using the requirement patterns, a function hierarchy spanning a tree with functions as leaves is conceived. While refining the complete system across subsystems into functions, the input and output interface of an element (i.e., the complete system or a subsystem) of one abstraction layer is partitioned onto elements of the next deeper abstraction layer (i.e., a subsystem or a function) in order to reduce the overall complexity of the SUD. Concrete examples for this can be found in our case study in Chapter 6. Furthermore, there are requirement patterns, which describe more detailed, solution-oriented requirements as described in the next chapter and comprise quality requirements, safety requirements, computation rules, internal states and their transitions, and activations or deactivations of functions, for example.

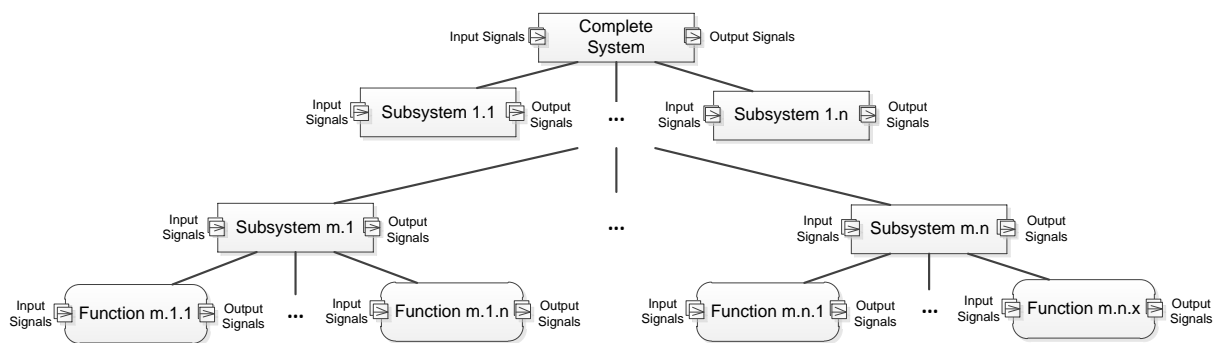

Figure 1: Function hierarchy described using requirement patterns (based on [Holtmann et al. 2011b])

In the subsequent development process, a logical architecture is developed manually based on the function hierarchy. Afterwards, the atomic leaf functions are allocated to logical components in order to document which function is realized by which component. A function can be allocated to one or more logical components. Alternatively, a logical component can also realize the functionality of several functions such that a set of functions is allocated to a single logical component (see [Fockel et al. 2012b]). The advantage of the distinction of system functionality and architecture is that it is possible to allocate the same functionality to different, concrete logical architectures. For example, the functionality of a BCM for a car and for a truck is the same, but the architecture is different due to the fact that in a truck more turn signal ECUs have to be controlled (see Chapter 6).

3.2 Textual Requirement Patterns

The CNL consists of textual templates for requirements (requirement patterns) with static, variable, alternative, and optional parts. The syntax is similar to that of regular expressions. Five example requirement patterns that are relevant for this paper are listed below. Some example requirements shaped by the requirement patterns 1–5 are listed in Table 1.

1. The system <system> consists of the following subsystem[s]: <subsystem list>.
2. The functionality of the system <system> consists of the following function[s]: <function list>.
3. The (system <system> | function <function>) (processes | creates) the following signal[s]: <signal list>.
4. When the event <event> occurs within the system <system> [and the condition <condition> is fulfilled], then the function <function> is (activated | deactivated).
5. The (system <system> | function <function>) has to react within <time> <timeUnit> to its stimuli.

In the above requirements patterns, the element <system> is a functional unit, that is, a grouping of functionality. Thus, *Complete System* in Figure 1 represents the functionality of the SUD, which is decomposed across the subsystems to atomic functions. These functions have a behavior which can be described as a relation between the input and output signals. The description of this behavior is not in scope of this paper and could be specified with free natural language, with formal models, or also with a CNL.

The element *signal* describes the input and output data of a function. All signals are defined in a central data lexicon (cf. the data dictionary from [DeMarco 1979]) and referenced by the requirements shaped by the patterns. Signals specify logical values and can be used to document the data flow between functions (e.g., velocity). Logical values are more abstract than concrete values, which may be specified during the design of the logical and technical architecture. For these architecture types, the interfaces are described in more detail and are mapped to technical signals such as bus signals. Hence, the input and output signals can be used to define interfaces in the logical and technical architecture.

ID	Requirement text
R1	The system <i>BodyControlModule</i> consists of the following subsystems: <i>ControlTurnSignals</i> , <i>ControlBrakeLight</i> .
R2	The functionality of the system <i>ControlTurnSignals</i> consists of the following functions: <i>Indicate</i> , <i>SwitchHazardLights</i> .
R3	The functionality of the system <i>ControlBrakeLight</i> consists of the following functions: <i>LightBrakeLights</i> , <i>SignalizeEmergencyBrake</i> .
R4	The function <i>LightBrakeLights</i> processes the following signal: <i>brake</i> .

R5	The function <i>LightBrakeLights</i> creates the following signal: <i>light</i> .
R6	The function <i>SignalizeEmergencyBrake</i> processes the following signal: <i>emergencyBrake</i> .
R7	The function <i>SignalizeEmergencyBrake</i> creates the following signal: <i>lightIntense</i> .
R8	The function <i>SignalizeEmergencyBrake</i> has to react within 25 ms to its stimuli.

Table 1: Example requirements specified with requirement patterns

Furthermore, requirement patterns specify events that trigger the activation or deactivation of functions. The event specifications can be augmented by conditions that must hold in order for the event to be triggered. These events and conditions are described with the fourth requirement pattern. There are further templates that formalize the variables *<event>* and *<condition>* from requirement pattern no. 4. These are listed in Table 2.

Event	<signal> (increases above decreases below reaches) <value>
	<signal> is turned (on off)
Condition	<signal> [is] [not] (greater than lower than equal to unequal to greater than or equal to lower than or equal to) <value> [is]
	<signal> (< > == <= >= <>) <value>

Table 2: Templates for events and conditions

By making use of the CNL outlined above, the expressiveness of natural language is restricted and thereby syntactically disambiguated. This fosters automatic processing of the requirements in several ways.

Firstly, we developed a prototypical requirements editing environment consisting of a tabular editor for the data lexicon, as well as a text editor to document the requirements using the requirement patterns explained above [Holtmann 2010]. The text editor employs features like error marking (e.g., in the case of text that does not correspond to the requirement patterns), syntax highlighting, auto completion, and the automatic generation of an overview of the current function hierarchy. These features support the requirements engineer in a constructive manner while formulating requirements.

Second, we developed an automatic requirements validation approach on top of the requirements editing environment [Holtmann et al. 2011b]. The validation approach automatically checks the overall requirements specification for wellformedness w.r.t. to predefined rules and guidelines. For example, we outlined in the last subsection that the inputs and outputs of the atomic functions should be propagated via the subsystems to the overall system. That is, in the final requirements specification each system should have the union of inputs and outputs of its subordinate elements (i.e., subsystems or functions). Regarding the requirements R3 – R7 in Table 1, the subsystem *ControlBrakeLight* should process the signals *brake* and *emergencyBrake* and create the signals *light* and *lightIntense* since

the subsystem's subordinate functions *LightBrakeLights*, *SignalizeEmergencyBrake* do so. Thus, there should be two requirements that specify that *ControlBrakeLight* processes and creates these input and output signals, respectively. Typically there is a huge amount of requirements, which are additionally distributed across several documents and document chapters. Thus, such missing requirements or requirement inconsistencies can easily be missed and therefore lead to problems in the subsequent development process. Such requirements defects can be identified by the requirements validation approach.

Finally, we ease the transition to model-based development by generating an analysis model [Fockel et al. 2012a; Fockel et al. 2012b; Holtmann et al. 2011a]. The analysis model reflects the same information as the requirements and represents the function hierarchy in a SysML Block Definition Diagram. For example, the analysis model in the bottom of Figure 2 reflects exactly the same information as the excerpt of requirements in Table 1. We use the analysis model as a basis to establish traceability to the logical architecture and for detecting missing or invalid traceability automatically [Fockel et al. 2012a]. For example, we outlined in the last subsection that all leaf functions of the analysis model have to be allocated to logical components in the subsequent development process. This is done by means of SysML allocation links between the elements of the analysis model and the logical components, amongst other things. If such trace links do not exist, we identify the corresponding functions or logical components by automatic checks. Furthermore, we also take the relations between the input and output information of the analysis model and the logical architecture into account. To execute the generation, we apply the bidirectional, synchronizing model transformation technique Triple Graph Grammars (TGGs) [Schürr 1995]. Once the analysis model has initially been generated based on the requirements documented using the requirement patterns explained above, TGGs allow keeping requirements and analysis model consistent automatically. This is done by repeatedly updating the parts of the analysis model that are affected by updated requirements. The other way round, it is also possible to change the analysis model and update the requirements that are affected by the changes in the model. Since TGGs store the correspondences between the analysis model and the documented requirements (cf. objects *:co1*, *:co2*, and *:co3* in Figure 2), traceability between them is established and maintained automatically [Fockel et al. 2012a].

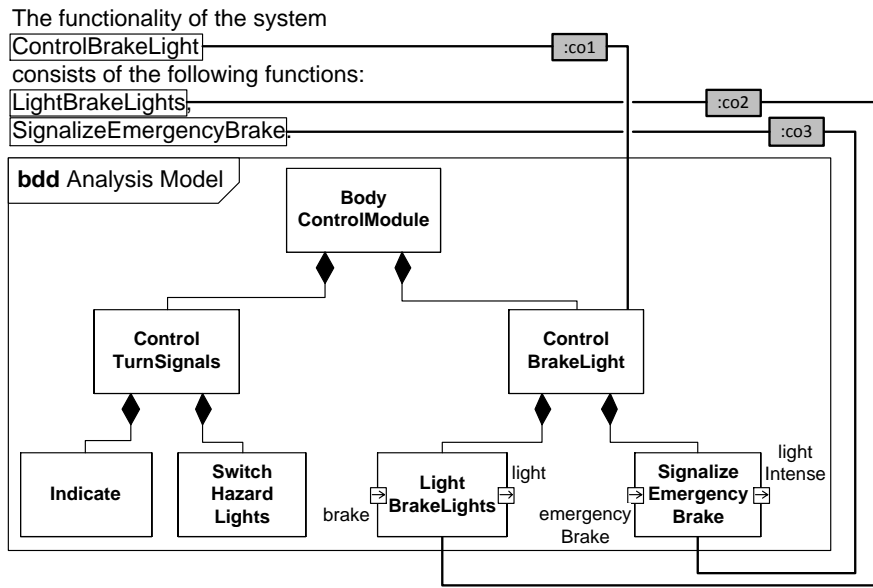

Figure 2: From requirements to analysis model (based on [Fockel et al. 2012a])

4 A Model-based Requirements Engineering Approach

A seamless model-based requirements engineering approach (MB-RE approach) has been developed with the aim to foster a systematic, model-based co-design between requirements and architecture². The approach is based on a goal-/scenario-oriented stepwise refinement of requirements from coarse, solution-neutral requirements to detailed, solution-oriented requirements.

Due to the stepwise, artifact-based refinement, the MB-RE approach allows for traceability between requirements artifacts. To enable the stepwise refinement, the MB-RE approach is based on two main concepts: A hierarchy of abstraction layers (see Section 4.1) and a requirements artifact model (see Section 4.2). In the following, we will summarize the key ideas of the MB-RE approach, its requirements artifacts and architectural artifacts.

4.1 The Abstraction Layer Model

One key feature of the MB-RE approach is a hierarchy of abstraction layers. Using different levels of abstraction is a proven way to reduce the complexity of development projects [Weber and Weisbrod 2003] and has also been successfully applied in a number of different research approaches (see, e.g., [Braun et al. 2010] and [Bühne et al. 2004]). The continuous model-based requirements engineering approach therefore offers hierarchical layers of abstraction for all requirements artifacts, which fosters the decomposition of the SUD in a systematic manner. At each abstraction layer, a number of different requirements models are developed: environment models, goal models, scenario models, and solution-oriented requirements, see Section 4.2. The commonality among the requirements models on one abstraction layer is that they contain requirements artifacts pertaining to the same set of concerns [Fine 2002]. Abstraction layers therefore differ from one another with regard to the level of detail of their requirements, such that some abstraction layers contain more coarsely specified requirements (in the following, called higher abstraction layers) and some layers contain more detailed requirements (so called lower abstraction layers).

As prior research shows (e.g., [Sikora et al. 2011]), it is futile to specify a rigid hierarchy of abstraction layers. This is due to the vastly different development projects in individual application domains such as automotive technology, avionics, medical, energy, or automation technology: Building a driver assistance system in the automotive industry is vastly different from building an assembly line in the automation industry. Consequently,

² The requirements viewpoint presented in [Daun et al. 2012] is based on the model-based requirements engineering approach sketched in this chapter.

using the same abstraction layer hierarchy in both endeavors might not be wise. Therefore, the MB-RE approach supports defining abstraction layers freely with regard to the development project and the application domain. In other words, a particular abstraction hierarchy must be defined according to the peculiarities that the project in the given application domain makes necessary. Therefore, the RE approach does not define a rigid abstraction hierarchy, but recommends a generic abstraction layer types that can be tailored towards project and application domain. In the following, the abstraction layer types and their properties and relations to one another are explained. In Figure 3, the abstraction layer hierarchy of the MB-RE approach is illustrated.

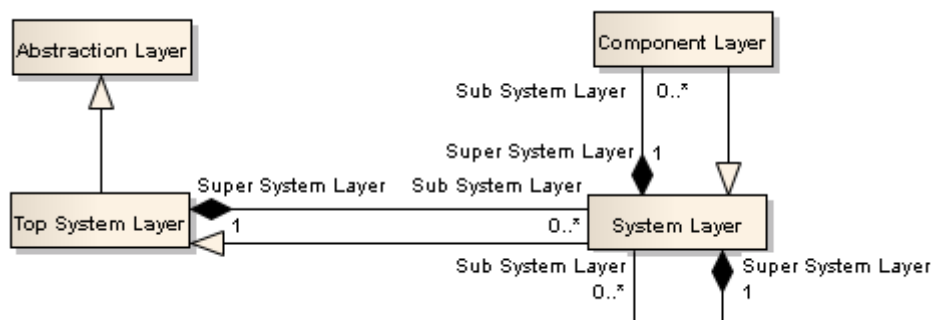

Figure 3: The Requirements View Abstraction Layer Hierarchy

4.1.1 Top System Layer

The *Top System Layer* is the most abstract layer. Usually, there is only one system specified at the *Top System Layer*. In this abstraction layer, the interfaces of the SUD with its environment and entities within the environment, such as users and other systems are captured. In addition, at this abstraction layer, physical and technical processes in the context of the system are captured. This abstraction layer presents the services and functions offered by the system using the artifact types outlined in Section 4.2. The requirements artifacts at this abstraction layer focus on the system's usage, while the architecture is mainly concerned with the definition of sub-systems.

4.1.2 System and Sub-System Layers

These layers consist of a number of different (sub-)systems that have been identified on the next higher abstraction layer during the development of the architecture artifacts. It hence contains the logical building blocks obtained from the decomposition of the overall system. There may be arbitrarily many of these layers, that is, a system specified on the *System Layer* may contain further sub-systems. These sub-systems are specified on the next layer, the *Sub-System Layer*. Sub-systems may themselves contain further sub-systems, which are in turn specified on the next lower sub-system layer, and so forth. Each of these layers usually contains more than one system. Hence, in contrast to the *Top System Layer*, the *System* and *Sub-System Layers* contain multiple systems. Consequently, the requirements engineering process has to be performed for each system and sub-system and must render artifacts that

are both consistent to one another (i.e., to the artifacts of other systems within this layer) and to the next higher layer.

4.1.3 Component Layer

The *Component Layer* is usually the lowest abstraction layer, disregarding from how many sub-system layers have been defined. This layer is largely similar to the sub-system layer(s). The main difference between System, Sub-System, and Component Layer is that the sub-systems specified at the Component Layer are not decomposed any further. Sub-systems that are not decomposed are considered atomic components. The Component Layer consists of hardware and software components that realize the entire system's properties. At this layer, the interrelation between software and hardware components is defined. Therefore, this layer ordinarily contains the physical building blocks of the entire system.

4.1.4 Using Abstraction Layers

There is no restriction regarding how many or how few abstraction layers must be defined. For example, if a very simple system is to be designed that is not further decomposed into sub-systems or components, or if the complexity of the system does not significantly decrease due to decomposition into sub-systems, the requirements engineer might choose to use merely one abstraction layer. This would be equivalent with specifying the system under development on the Top System Layer. On the other hand, it is also possible to use two or more abstraction layers. Using two abstraction layers is equivalent to specifying the requirements on the Top System Layer and Component Layer, respectively. In the case that more than two abstraction layers are used, requirements are also specified on at least one System Layer.

4.2 The Artifact Model

Research in model-based requirements engineering must provide RE approaches that do not only give methodological guidance with regard to the use of abstraction, but also with traceability and consistency of requirements artifacts that are specified during the RE process [Sikora et al. 2011]. In other words, it must be possible to trace requirements artifacts throughout the development process [Gotel and Finkelstein 1994]. By means of the stepwise refinement of requirements artifacts on different layers of abstraction (see Section 4.1), the MB-RE approach provides one way to achieve both traceability and consistency. One further device to ensure traceability and consistency in this model-based requirements engineering approach is the inherent artifact model. Artifacts types used in this approach are environment models, solution-neutral requirements, that is, goal and scenario models, solution-oriented requirements models in the perspectives behavior, function, and data, as well as architecture models. In the following, we briefly explain the different artifact types of the RE approach shown in Figure 4.

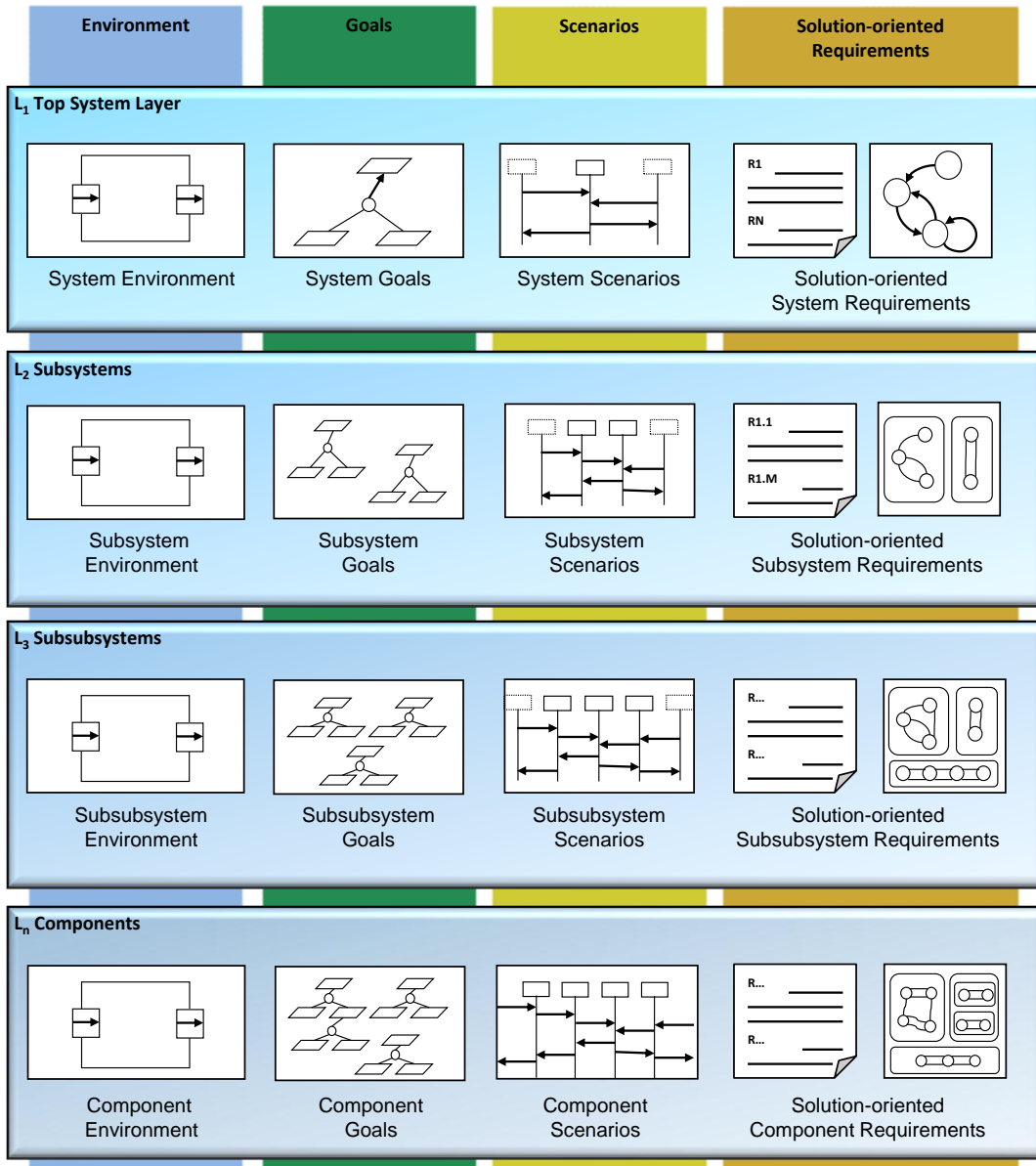

Figure 4: The Artifact Model of the MB-RE approach

4.2.1 Environment Models

Environment models treat the system as a black box and focus on the systems desired interaction with its environment and entities within its environment (context entities, see [Weyer 2010]). Context entities are, for example, external actors, sensors, and other systems in the context of the system. Environment models focus on the definition of the system's external interfaces, that is, the interfaces the system has with its environment and the context entities. The environment models defined at the System Layer are the basis for communication with stakeholders such as customers, users, product managers, or sales representatives. These models allow eliciting system goals and give a first impression about the system's interaction with the environment, that is, the functions that can be perceived in the environment that are performed by the system under development. A detailed

description of context models can be found in [Weyer 2010]. Structural diagrams such as SysML Internal Block Diagrams can be used to model this artifact type.

4.2.2 Solution-neutral requirements

Solution-neutral requirements are used to document rationales for solution-oriented requirements. There are two types of solution-neutral requirements: goal models and scenario models.

Goal models document the intentions that the stakeholders have when conceiving the system and can sketch alternative realization options. In early requirements engineering, using goal models helps to focus on identifying the problems and exploring the system solutions and alternatives. Goals form a first manifestation of the vision about the system that the stakeholders have in mind. Goals are solution-neutral descriptions of the functionalities, qualities, and features the system under development must possess. Goals neglect concrete aspects of the solution. In goal models, relationships between goals, functionalities, and qualities can be identified. For example, goals might be in direct conflict with each other (i.e., fulfilling one goal will make it impossible to fulfill a conflicting goal) or the fulfillment of goals may contribute—positively or negatively—to the fulfillment of another goal (i.e., make it easier or harder to achieve the other goal). Goals can be elicited, in part, from the environment model, but also by means of stakeholder collaboration. The MB-RE approach differentiates between hardgoals, that is, goals whose fulfillment can be unambiguously verified (e.g., by yes/no questions), and softgoals, which are goals whose fulfillment depends on some degree of interpretation (e.g., goals pertaining to the quality aspect “usability”). Goals and goal modeling is explained in detail in [Pohl 2010] as well as [van Lamsweerde 2009]. KAOS goal diagrams, i* models, or stereotyped SysML Requirements Diagrams can be used to model this artifact type.

Scenario models are exemplary interactions of the system with its environment. Scenarios allow eliciting requirements by modeling the system's interaction with context entities that have been identified in the environment models. Thereby, the system's benefit and impact on the environment can be assessed. Scenarios fulfill the goals that have been specified in the goal models. For every goal, there must be at least one scenario that fulfills it and every scenario must fulfill at least one goal. Furthermore, scenarios may specify some internal states, albeit the state space of the system under development can usually not be fully modeled using scenarios. This is due to the fact that scenarios merely model exemplary interactions of the system with its environment, rarely all interactions. Scenario modeling is described in detail in [Pohl 2010] as well as [Potts 1995]. Additionally, alternative and error handling scenarios can be specified that describe exceptional interactions deviating from the main scenarios. SysML Use Case and Sequence Diagrams as well as ITU Message Sequence Charts can be used to model this artifact type, for example.

4.2.3 Solution-oriented requirements

Solution-oriented requirements are solution-specific descriptions of behavior, functions, and data (the three perspectives, see [Pohl 2010] and [Davis 1993]) and thus represent a first step towards the implementation. Solution-oriented requirements consist of data models, functional models, and state models which represent the data, function, and behavior perspective, respectively. Solution-oriented requirements can insofar be derived from scenario descriptions as scenarios may specify states that the system adopts after a certain interaction sequence has been executed. Furthermore, on the basis of scenarios and environment models, the function perspective of solution-oriented requirements can be derived in part. All three perspectives of solution-oriented requirements are co-developed, as they present individual views onto the same system. A more detailed explanation of solution-oriented requirements is given in [Pohl 2010]. SysML Block Definition Diagrams are used for the data perspective, SysML Activity Diagrams are used for the function perspective, and SysML State Machine Diagrams are used for the behavior perspective to model solution-oriented requirements.

4.2.4 Combining solution-neutral and solution-oriented requirements across Abstraction Layers

Goal- and scenario-oriented RE approaches appear to be considered a beneficial approach for practitioners [van Lamsweerde 2009] as an essential component involved in the requirements engineering process. Typically, in goal- and scenario-oriented approaches, the context is analyzed, problems are identified, and high level strategic goals for developing a system to solve the problems are elicited. Consequently, solution-oriented requirements are specified to fulfill these goals. Thus, goals are guiding the requirements elicitation process and are identified on the basis of environment artifacts. However, goals merely reflect an idealized view of the desired context, that is, depict a desired state of the system after development. Thus, requirements elicitation should not rely only on goals. It needs a combination with another facilitating option which should give some information of current reality. For this purpose, scenarios can be used which represent sequences of real events in the context. Solution-oriented requirements are specified on the basis of goals and scenarios and build the immediate input for architecture models. Developing these artifacts for some system, sub-system, or component on some abstraction layer is in principle a sequential process. However, during the requirements engineering process, particular attention must be placed on maintaining consistency between the requirements artifacts. While the relationships between these artifacts as explained above already allow for traceability and consistency, consistency checks must be performed whenever an artifact is completed so that the artifacts do not contradict one another. For example, behavior models as well as scenario models must be checked for consistency across abstraction layers in order to ensure that the scenarios specified on the lower abstraction layers are correct refinements of the scenarios on the higher abstraction layer (cf. [Sikora et al. 2010]).

5 Combining Controlled-Natural-Language-based and Model-based Requirements Engineering

Informal requirements can be formulated and formalized by means of requirement patterns using the controlled-natural-language-based RE (CNL-RE) approach illustrated in Chapter 3. While natural language is the preferred documentation format for legally binding requirements documents and for document-oriented reviews, there is a tendency and desire among requirements engineers to use models during the RE process [Sikora et al. 2012]. For this reason, we integrate the CNL-RE approach shown in Chapter 3 with the model-based RE (MB-RE) approach explained in Chapter 4. This enables to switch the documentation format at certain points in time. In the remainder of this section, we present the basic methodology of the integrated approach. In Chapter 6, we evaluate the applicability of the approach by means of the case study “Body Control Module”.

5.1 Methodology Adaptation

In order to integrate the CNL-RE and the MB-RE approach, we adapted the methodology of the latter one. The key change is that all artifacts describe a functional view of the SUD as in the CNL-RE approach. Furthermore, the use of scenarios of the MB-RE approach enables to conceive the function hierarchy of the CNL-RE approach in a more systematic way. Based on this functional view, the logical architecture of the SUD is developed as outlined in the Chapter 3. This is explained in more detail in the following section.

5.2 Combined Process Model

Figure 5 shows the integrated methodology. The color scheme in Figure 5 is based on the color scheme in Figure 4, yet has been extended to depict activities that produce artifacts based on the controlled-natural-language-based component of the combined RE approach. That is, the red activities 5 and 10 regarding the function hierarchy of the SUD. Furthermore, some artifacts of the MB-RE approach can alternatively be represented by means of requirement patterns, see activities 6 and 11.

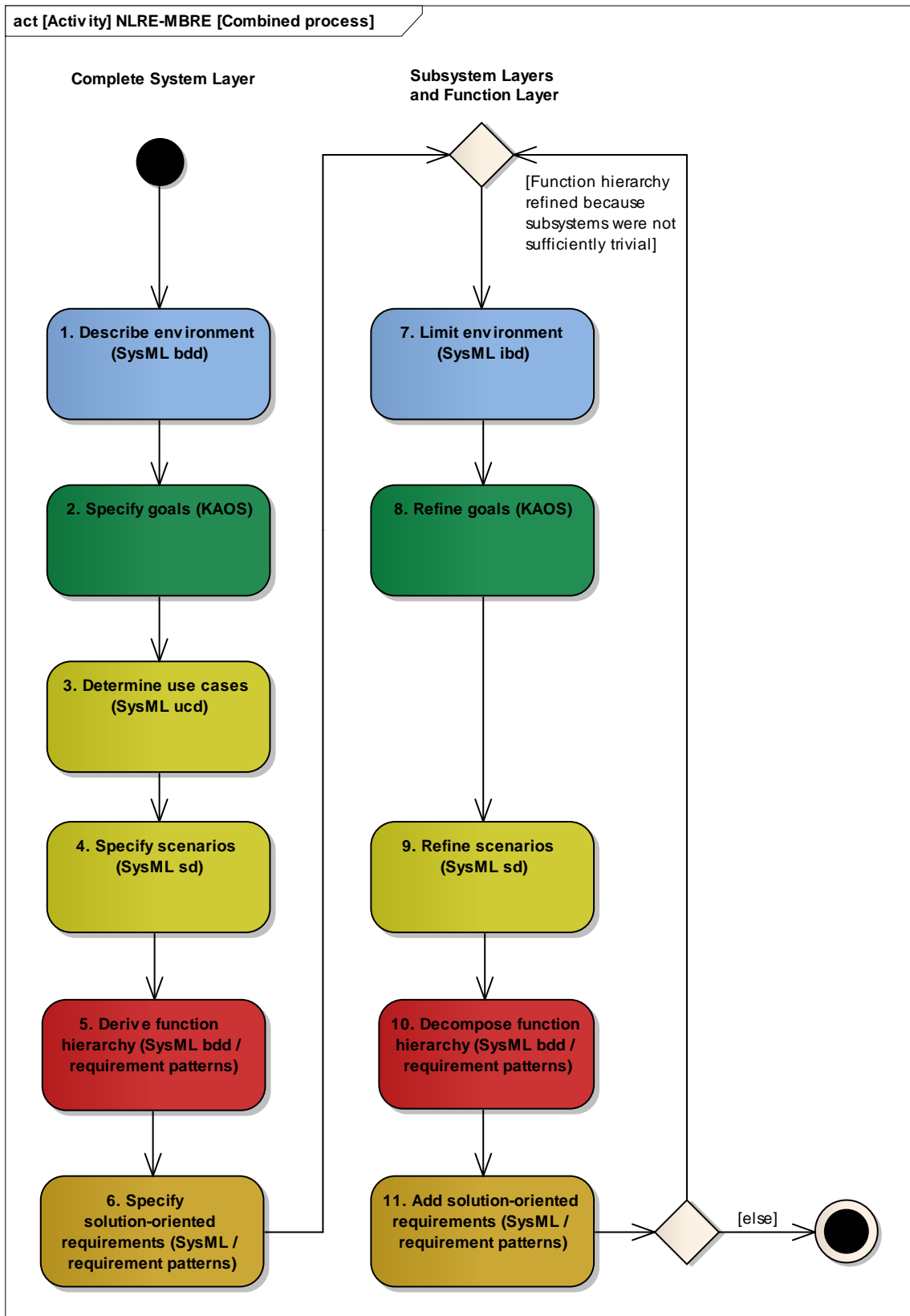

Figure 5: Process for the integrated methodology

As it can be seen from Figure 5, the integrated methodology is divided into two parts. First, the functionality of the SUD is considered in its entirety on the so-called *complete system layer*

(cf. the complete system in Section 3.1 and the Top System Layer in Section 4.1). Similarly to the methodology of the CNL-RE approach (cf. Section 3.1), the system layer is refined across several subsystem layers to the deepest function layer afterwards. In the following, we explain the particular steps of the methodology in more detail.

Please note that the steps 7 through 11 may be repeated for any subsequent abstraction layer. Furthermore, Figure 5 as well as our case study could be interpreted in such a way, that only a sequential requirements engineering process similar to the waterfall model for the whole software development process [Royce 1970] is allowed. But, of course, iterations are explicitly allowed in our RE process.

5.2.1 Step 1: Describe Environment

First of all, the environment of the SUD is described. From the viewpoint of a supplier, the environment typically consists of other ECUs of the car. The environment has to be determined based on the informal customer requirements of the OEM. The key difference to the MB-RE approach is that the context of the SUD (i.e., its environment) is considered in a purely functional manner. That is, we model no concrete ECUs but their functionalities, which are required or requested by the SUD. The system environment is described by means of a SysML Internal Block Diagram.

5.2.2 Step 2: Specify Goals

In the second step, the goals of the SUD are specified. These goals are not always known to a supplier that has to develop a system for an OEM. In this case, the goals have to be determined based on the customer requirements. In the ideal case, the OEM additionally forwards the goals together with the customer requirements to the supplier. As in the MB-RE approach, the goal artifacts are modeled using KAOS goal diagrams [van Lamsweerde 2009]. In order to achieve UML-/SysML-compliant artifacts, we apply stereotyped UML class diagrams as concrete notation for the KAOS goal diagrams.

5.2.3 Step 3: Determine Use Cases

Third, the use cases of the SUD are determined based on the customer requirements. They are documented by means of use case diagrams like in the model-based RE approach.

5.2.4 Step 4: Specify Scenarios

In the fourth step, the use cases are described in a more detailed way using scenarios. All information needed for modeling the use cases and scenarios is determined based on the customer requirements and the goals the scenarios have to fulfill. The interacting objects are elements of the environment that has been specified in step 1. Each scenario is modeled by means of a sequence diagram.

5.2.5 Step 5: Derive Function Hierarchy

In this step, the functionality of the SUD is decomposed into subsystems (cf. Chapter 3). These subsystems are decomposed in the following iterations until the function layer is reached (cf. Step 11). This layer contains the atomic functions. Therefore, as explained in Chapter 3, this decomposition results in a function hierarchy. This step specifies function hierarchies based on the scenarios specified in Step 4 in a manner consistent with the CNL-RE approach (cf. Section 3.1). As in the CNL-RE approach, the model-based representation of the function hierarchy is specified by means of a SysML Block Definition Diagram.

5.2.6 Step 6: Specify Solution-oriented Requirements

Solution-oriented requirements for the complete system can be specified in this step using the textual requirement patterns of the CNL-RE approach. As explained in Chapter 3, the patterns encompass besides the description of the SUD functionality also quality and safety requirements, computation rules, internal states and their transitions, and activations or deactivations of functions, for example. Typically, these solution-oriented requirements are formulated in deeper abstraction layers. In this integrated methodology, only the functional perspective of solution-oriented requirements is being considered as it serves as the basic input for the decomposition using requirement patterns. The behavioral and structural perspective can also be specified in addition, but the focus of this combined approach is on system functions.

5.2.7 Step 7: Limit Environment for each Subsystem on the next Abstraction Layer

In this step, the environment that was specified on the preceding (sub)system layer is cut down on those elements that are relevant to the subsystems of the currently considered layer. Each subsystem is considered individually. The other subsystems on the same layer, which are interacting with the considered subsystem, are as well regarded as functionalities of the environment. This is specified by means of a SysML Internal Block Diagram as in the environment description of the complete system layer.

5.2.8 Step 8: Refine Goals for each Subsystem on the next Abstraction Layer

If necessary, the specified goals are refined for the subsystems, which have been newly added to the function hierarchy. Furthermore, new goals can be added to the initial class diagram derived from step 2.

5.2.9 Step 9: Refine Scenarios for each Subsystem on the next Abstraction Layer

The scenarios of the superordinate (sub)system layer are refined in this step. To do so, the superordinate (sub)system(s) are replaced by the subsystems or functions, which have been newly added at the currently considered layer. The message exchange is adapted accordingly. As in step 4, sequence diagrams are applied for the specification of the scenarios.

5.2.10 Step 10: Decompose Function Hierarchy

If the subsystems newly added at the previous layer of abstraction can be decomposed, this is done in this step by further decomposing them in the SysML Block Definition Diagram representing the function hierarchy. In this case, a new subsystem layer is conceived. A subsystem is trivial, if all relevant stakeholders have a sufficient understanding about the subsystem's functionality without further decomposition. In this case, the subsystems represent atomic functions, which do not need to be decomposed any further. Thus, the currently considered layer is the function layer, and the requirements engineering process is completed after step 11.

Since we conceived a correlation—formalized using bidirectional TGG model transformations—between the function hierarchy (cf. the analysis model in Chapter 3) and Natural-Language-based requirements formulated by means of requirement patterns, we can automatically transfer the function hierarchy to textual requirements. This is especially important in the case of reviews that typically impose a document-oriented structure. Furthermore, if changes occur in the textual review version, these changes can automatically be transferred to the function hierarchy again.

5.2.11 Step 11: Add Solution-oriented Requirements for each Subsystem on the next Abstraction Layer

If further solution-oriented requirements are identified while refining the functionality of the SUD, they are formulated by means of requirement patterns in this step.

If the function layer was reached in step 10 (i.e., the subsystems were not decomposed any further), the process is completed.

5.2.12 End of Process

After the requirements engineering process has been completed, the resulting function hierarchy as well as the solution-oriented requirements can be transferred to the final system requirements specification document.

Based on the function hierarchy, a logical architecture is manually conceived at the end of the requirements engineering process. The traceability between the atomic functions of the function hierarchy and the logical components is documented by SysML allocation links ([Fockel et al. 2012a]; [Fockel et al. 2012b]).

6 Case Study: Automotive Body Control Module

In this chapter, we present the case study “Body Control Module” (BCM) from the automotive domain, which comprises an excerpt of the functions of a BCM used in today’s cars. The case study is structured on three layers of abstraction, the complete system layer, which contains a functional view of the BCM as a whole (the topmost system in the function hierarchy) (see Section 6.1), the subsystem layer, which comprises function groups that are part of the BCM (see Section 6.2), and the function layer, which contains individual, atomic functions that are not further decomposed (see Section 6.3). In the following, each section describes the artifacts that are developed on the corresponding layer of abstraction and structures them according to the subsystem that they belong to.

6.1 Complete System Layer

This section describes the topmost layer of abstraction, which considers the functions of the BCM as a whole. The development starts with the elicitation and the subsequent documentation of solution-neutral requirements artifacts (see Section 4) in order to structure the problem space of the SUD. In the following, these artifacts are described in detail.

6.1.1 Environment of the BodyControlModule

In this first step, the environment of the SUD is specified. Figure 6 depicts an Internal Block Diagram containing the system *BodyControlModule* and five environment functions represented by actors, that is, *DashboardControlling*, *BrakePedalLevelSensing*, *LeftIndication*, *RightIndication* and *BrakeLightSwitching*. The five environment functions and the SUD are connected to each other by a total of interfaces.

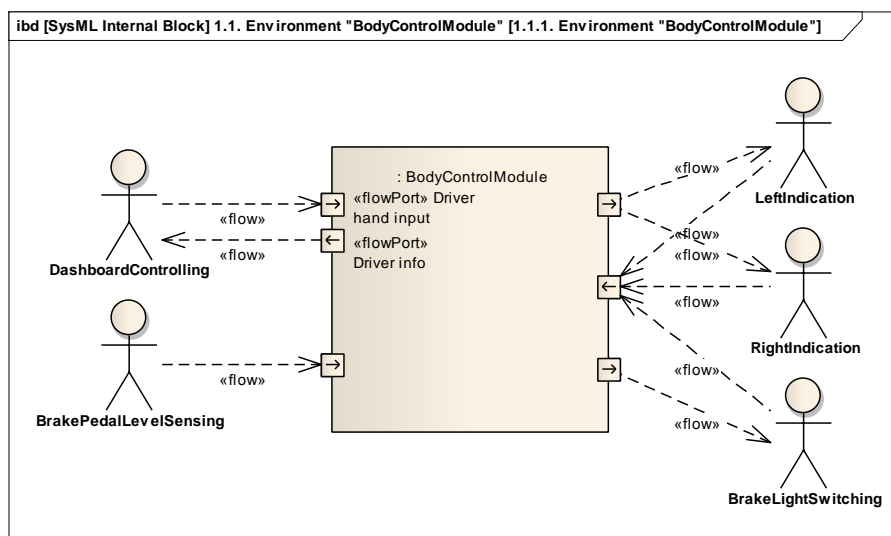

Figure 6: Environment of the *BodyControlModule* on Complete System Layer

As can be seen in Section 4, environment models describe the embedding of the SUD into its environment. Relevant functions within the environment of the SUD are identified and their inputs into the SUD and the outputs from the SUD that they receive are documented. Each input or output constitutes an interface of the SUD with the context. In consequence, the environment models serve as the foundation for further development activities, such as goal elicitation (see Section 6.1.2). The key difference to the MB-RE approach is that the context of the SUD is considered in a purely functional manner. For example, the model contains an environment function *DashboardControlling* instead of a concrete ECU *HumanMachineInterface*.

While the system *BodyControlModule* represents the overall functionality of the SUD (cf. Chapter 3), the purpose of the environment functions is the following:

- The function *DashboardControlling* provides the BCM with the current position of the turn signal lever, information about the status of the hazard lights button, and means to light LEDs in the dashboard as feedback to the driver.
- The function *BrakePedalLevelSensing* provides the BCM with the current position of the brake pedal.
- The functions *LeftIndication* and *RightIndication* control the left and right turn signals, respectively.
- The function *BrakeLightSwitching* allows lighting the car's brake lights.

The concrete signals of the functions are not yet considered in this step but in the Sections 6.1.3 and 6.1.4. In the next step, the goals that the environment functions expect the SUD to fulfill can be derived based on information of this environment model.

6.1.2 Goals on Complete System Layer

In the second step, the goals for the SUD are specified within a goal diagram.

In Figure 7, a goal diagram describing the refinement of BCM goals in its subgoals is shown. Legal regulations shall be fulfilled and rear-end collisions shall be avoided by means of the turn signal and brake light control. Thus, the two root goals *Fulfillment of legal regulations* and *Avoidance of rear-end collision* are refined by the goals *Notify of change in direction*, *Notify of slowdown* and *Notify of dangerous situation*. In subsequent steps, the indication of a direction change can be realized by a turn signal control, and the notification of a slowdown can be realized by a brake light control. The goal *Notify of dangerous situation* is refined by the goals *Notify of emergency braking* and *Notify of danger by halting*. Dangerous situations caused by a vehicle standstill (e.g., a car broken down or at the tail end of a traffic jam) can be indicated by using the hazard lights. An emergency brake shall be indicated by lighting the brake lights intensely and additionally activating the hazard lights.

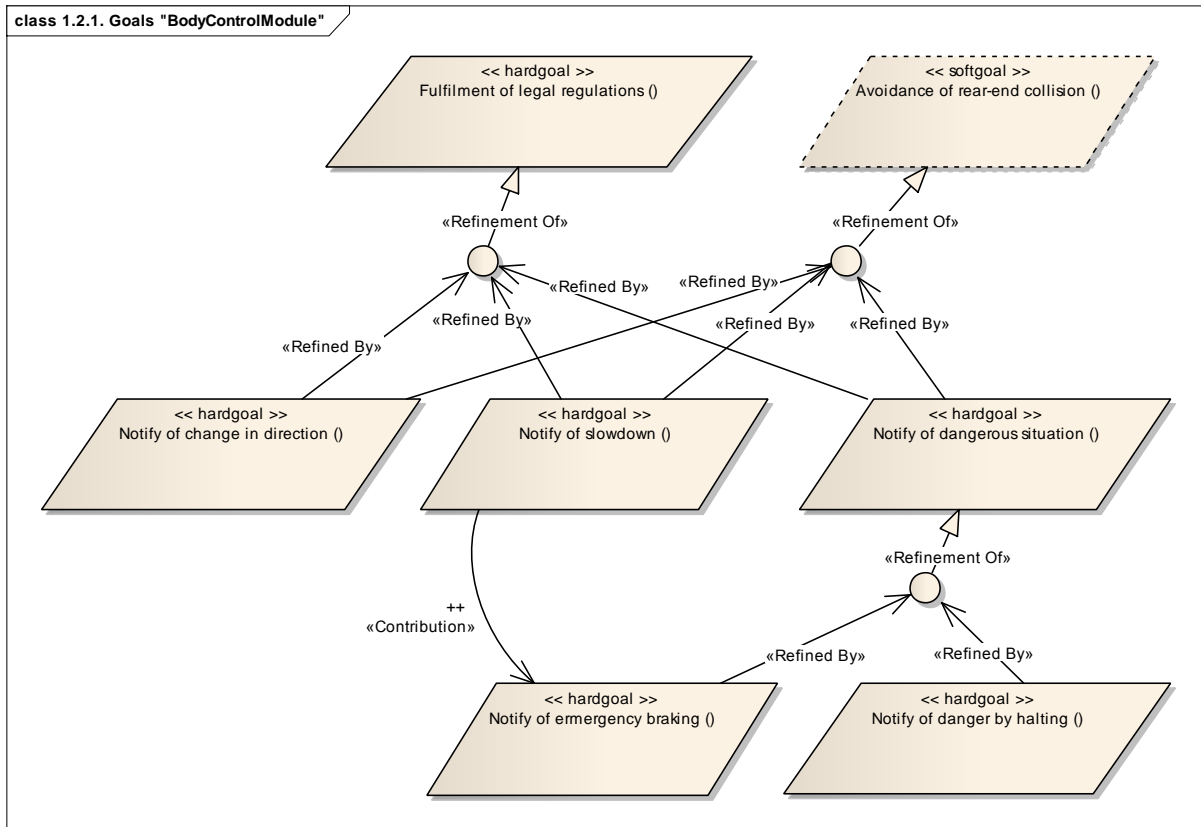

Figure 7: Goals on Complete System Layer

As described in Section 4.2.2, goals can be divided in hardgoals and softgoals. In the example, it is possible to verify that the legal regulations are fulfilled or that an emergency brake is successfully indicated. But, of course it is not possible to verify that the BCM avoids rear-end collisions for the whole lifecycle of all cars that have the BCM build in, since the car driver as well as the environment is another important factor w.r.t. collisions, for example. Thus, the goal *Avoidance of rear-end collision* is a softgoal.

Furthermore, the goal *Notify of slowdown* is a positive contribution for the goal *Notify of emergency braking* (indicated by the ++), since an emergency brake is a form of a slowdown, too. If the goal *Notify of slowdown* is already fulfilled, then the goal *Notify of emergency braking* is easier to fulfill. Negatively contributing goals are not included in this case study.

6.1.3 Use Cases and Scenarios on Complete System Layer

In the third step, the use cases and scenarios of the SUD are determined on the basis of the informal requirements, the environment model, and the goals specified in the last step.

In Figure 8, a use case diagram is given, which is used to structure the scenario models. In this example, the use cases *Indicate left*, *Indicate right*, and *Switch hazard lights* are specified for functionality w.r.t. the turn signals. The environment function *DashboardControlling* participates in these use cases. The environment functions *LeftIndication* and *RightIndication* participate on the use cases *Switch hazard lights*, *Indicate left*, and *Indicate right*.

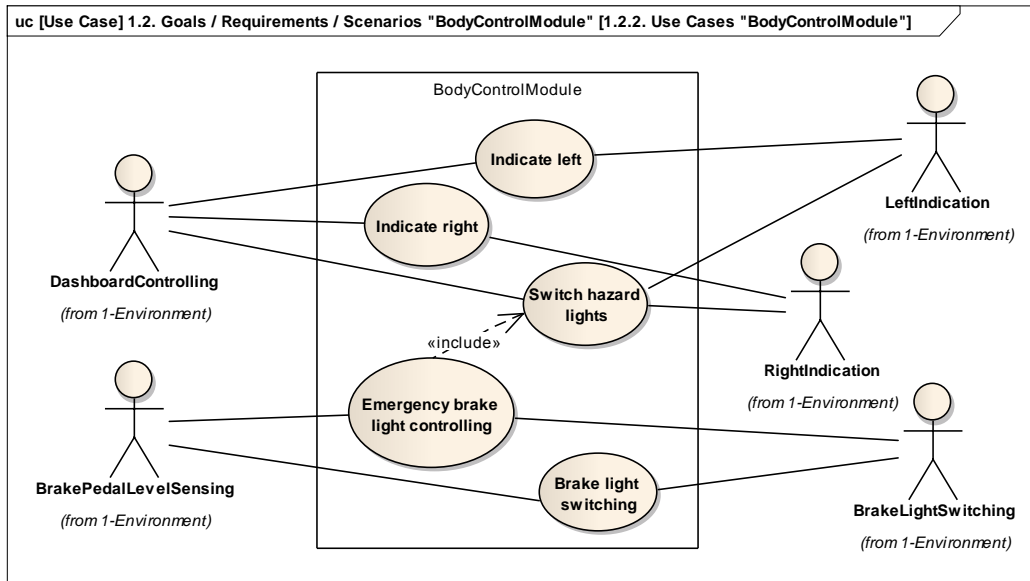

Figure 8: Use Cases on Complete System Layer

Furthermore, there are the use cases *Brake light switching* and *Emergency brake light controlling* w.r.t. the functionality of the brake light. The environment functions *BrakePedalLevelSensing* and *BrakeLightSwitching* participate on both these use cases. As can be seen from the use case diagram, the scenario *Emergency brake light controlling* includes the scenario *Switch hazard lights*. This means that the scenario *Emergency brake light controlling* achieves its functionality by additionally executing the other scenario. In other words, the hazard lights are activated when the driver strongly pushes the brake pedal.

In the fourth step, the use cases mentioned above are detailed with scenario models using sequence diagrams. In this case study, each use case corresponds to one scenario. In Figure 9 and Figure 10, two examples of scenarios are shown that show possible fulfillments of goals.

In Figure 9 a sequence diagram called *Indicate left* is given that depicts the exemplary fulfillment of the goal *Notify of change in direction*. The scenario depicted in the sequence diagram shows the SUD, *BodyControlModule*, as well as two environment functions, which have been taken from the environment model in Figure 6. When the driver uses the turn signal lever to indicate a left turn, the environment function *DashboardControlling* sends the message *indicateLeftReq* to the *BodyControlModule*. Subsequently, the *BodyControlModule* sends the message *indicateAct* to *LeftIndication* to activate the left turn signals and finally sends a *lightIndicateLeftLED* message back to *DashboardControlling* to activate a corresponding LED on the dashboard. This interaction is one possible way the goal *Notify of change in direction* can be fulfilled – another example would be the corresponding scenario *Indicate right* for right indication.

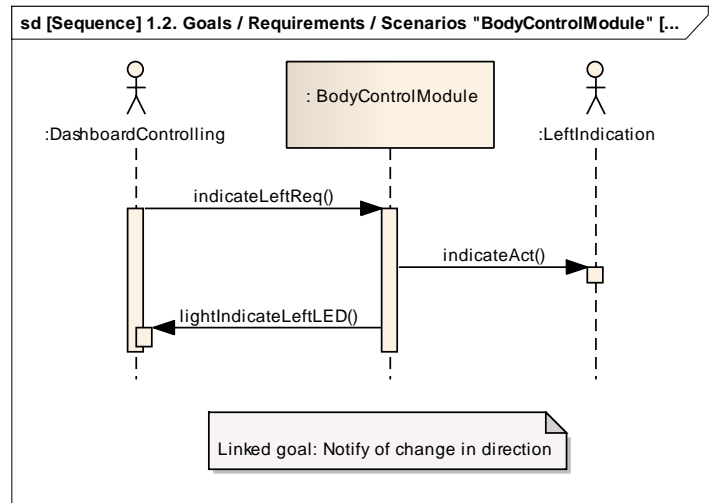

Figure 9: Scenario *Indicate left* on Complete System Layer

Another example is given in Figure 10. In this figure, a sequence diagram called *Emergency brake light controlling* is shown. It describes the interaction taking place, when the driver strongly pushes the brake pedal because of an emergency. The diagram shows six lifelines: the *BodyControlModule* as well as five environment functions, that is, *BrakePedalLevelSensing*, *BrakeLightSwitching*, *LeftIndication*, *RightIndication* and *DashboardControlling*. The scenario starts with the *BodyControlModule* receiving the message *emergencyBrake* from the environment function *BrakePedalLevelSensing*. Upon receiving that message, the system sends a *lightIntense* request to the environment function *BrakeLightSwitching* to make the brake lights light up more intensely. Then, two parallel *indicateAct* messages are sent to the environment functions *LeftIndication* and *RightIndication* to activate the hazard lights. Finally, the *BodyControlModule* sends a *lightHazardLightsLED* to *DashboardControlling* to make the activated hazard lights visible to the driver. The scenario shows the fulfillment of the goal *Notify of emergency braking* as documented in Figure 7.

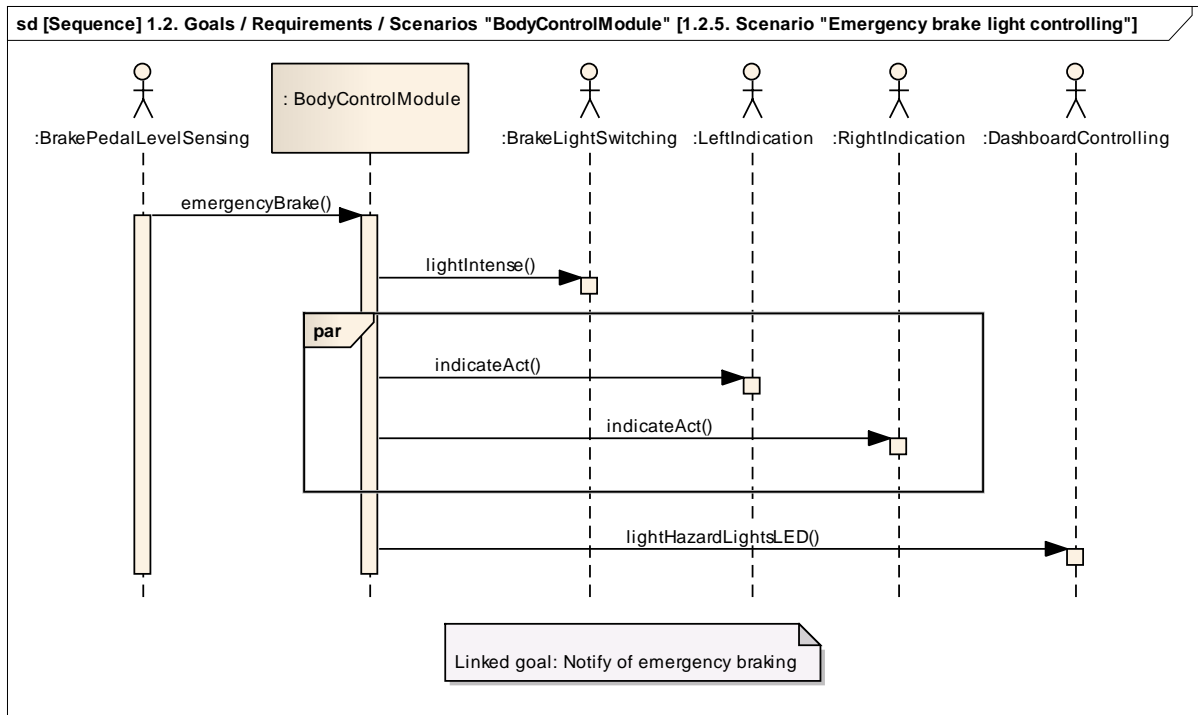

Figure 10: Scenario *Emergency brake light controlling* on Complete System Layer

As mentioned in Section 4.2.2, alternative and error scenarios can be specified besides the main scenarios. This type of scenarios can be used to describe a possible malfunction of the SUD and a suitable reaction to this w.r.t. one or several use cases. Figure 11 presents the error scenario *Handle left lamp defect* that occurs if the lamp of the left turn signal fails. When the status signal about a lamp defect is sent by *LeftIndication* to *BodyControlModule*, a warning lamp shall be activated in the dashboard to indicate this malfunction to the driver (message *lightIndicatorLampDefectLED*).

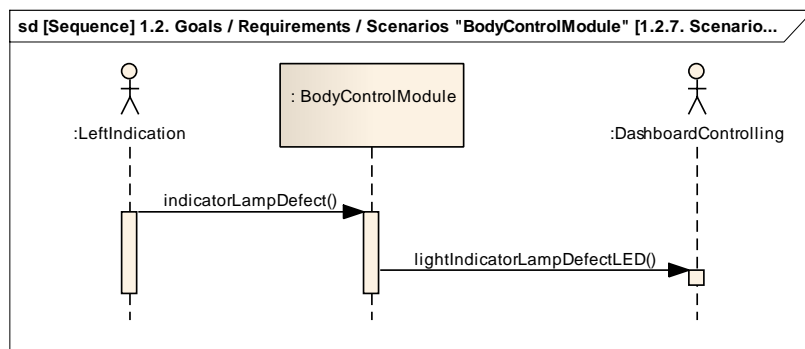

Figure 11: Scenario *Handle left lamp defect* on the Complete System Layer

This concrete error scenario is involved in the use cases *Indicate left* and *Switch hazard lights*, since the malfunction of the left turn signal lamp affects the correct execution of the main scenarios of these use cases. That is, the intended result of the use cases (the post condition that the corresponding lamp is lightened up) cannot be achieved due to the occurred malfunction. Analogously to the error scenario *Handle left lamp defect*, there are error

scenarios for the malfunction of the right turn signal lamp and of the brake lights, which are not shown in this document.

6.1.4 Function Hierarchy on Complete System Layer

After describing goals, use cases and scenarios on complete system layer, the functionality is consolidated in a structural view, the function hierarchy. On complete system layer this hierarchy consists of one element only. In our example that is the *BodyControlModule*. Figure 12 displays the complete system *BodyControlModule* including the entirety of its input and output interfaces that were determined using the scenario models. For example, in the scenario *Indicate left* (cf. Figure 9) it was determined that the BCM processes the input signal *indicateLeftReq* and creates the output signals *indicateAct* and *lightIndicateLeftLED*. Furthermore, in the scenario *Emergency brake light controlling* (Figure 10) it was specified that the BCM processes the input signal *emergencyBrake* and creates the output signals *lightIntense*, *indicateAct* and *lightHazardLightsLED*. Thus, these signals have to be part of the corresponding interfaces of the complete system *BodyControlModule* as shown in Figure 12. The rest of the ports stems from further scenarios that are not shown in this document. Note, that this view is a concretization of the specified SUD in the environment model from Figure 6. Furthermore, this is the topmost layer of the function hierarchy that is further decomposed in the following.

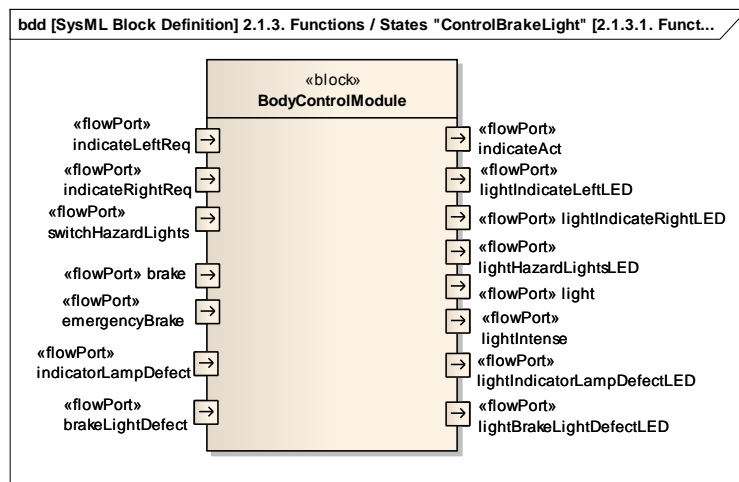

Figure 12: Function Hierarchy on the Complete System Layer

In order to further decompose the function hierarchy, groups of functionality in form of subsystems that encapsulate part of the complete system's functionality are conceived. Figure 13 shows the decomposed function hierarchy. The functionality of the complete system *BodyControlModule* is decomposed into the partial functionalities covering the turn signals (subsystem *ControlTurnSignals*), brake lights (subsystem *ControlBrakeLight*), and the indication of lamp defects (subsystem *HandleLampDefect*). This decomposed function hierarchy serves as input for the subsystem layer, which is described in Section 6.2.

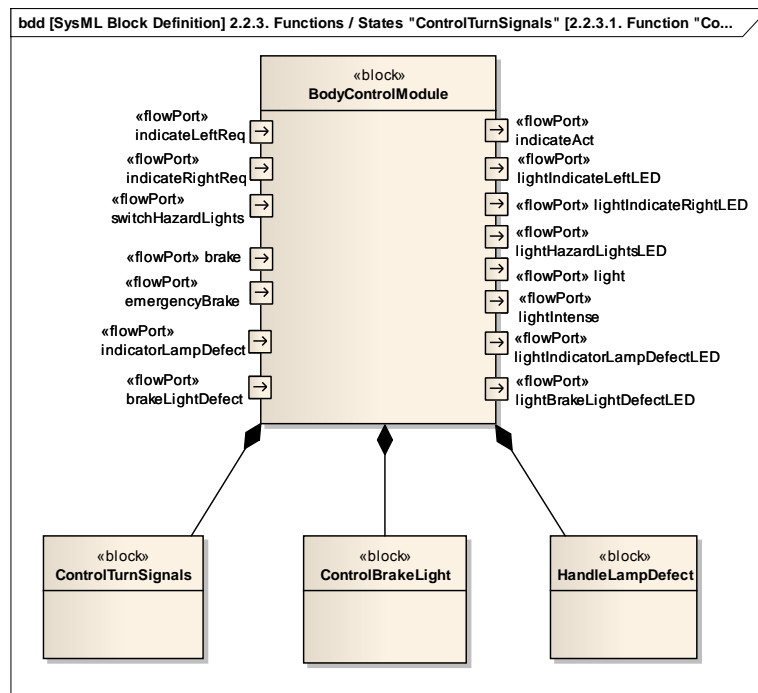

Figure 13: Initial Function Hierarchy on the Subsystem Layer

6.1.5 Solution-oriented Requirements on Complete System Layer

In this case study, solution-oriented requirements are only added on the lowest abstraction layer.

6.1.6 Requirement Pattern Representation of Function Hierarchy on Complete System Layer

Before the functionality of the complete system is decomposed for the next layer of abstraction, a switch to the natural language-based requirement specification could be performed in order to enable manual reviews in a document-oriented format. The resulting requirement pattern instances are listed below:

- The system *BodyControlModule* processes the following signals: *indicateLeftReq*, *indicateRightReq*, *switchHazardLights*, *brake*, *emergencyBrake*, *indicatorLampDefect*, *brakeLightDefect*.
- The system *BodyControlModule* creates the following signals: *indicateAct*, *lightIndicateLeftLED*, *lightIndicateRightLED*, *lightHazardLightsLED*, *light*, *lightIntense*, *switchHazardLights*, *lightIndicatorLampDefectLED*, *lightBrakeLightDefectLED*.
- The system *BodyControlModule* consists of the following subsystems: *ControlTurnSignals*, *ControlBrakeLight*, *HandleLampDefect*.

6.2 Subsystem Layer

This chapter includes the next layer of abstraction, which specifies each subsystem of the BCM in more detail.

6.2.1 Limited Environment on the Subsystem Layer

In the first step on this layer, the signal interface of the complete system *BodyControlModule* is partitioned to its subsystems that were conceived on the previous layer (cf. Section 6.1.4) w.r.t. the signals they have to process and create to fulfill their specific functionality.

Figure 14 describes the environment of the subsystem *ControlIndicators*. It is derived from the functional decomposition on the previous layer (cf. Figure 13) and is the initial input for any further elicitation of functionality in the following steps for this particular subsystem. The communication for the indicator and hazard lights requests as well as for activating the LEDs in the dashboard takes place with the environment function *DashboardControlling*. Because the hazard lights shall be activated if an emergency brake occurs, an internal message *switchHazardLightsInternal* can be received from the subsystem *ControlBrakeLight*. From the viewpoint of the subsystem *ControlTurnSignals*, the other subsystem *ControlBrakeLight* is part of its environment. Thus, it is specified as an environment function in this model. The environment functions *LeftIndication* and *RightIndication* can receive the corresponding activation requests *indicateAct* for indicating.

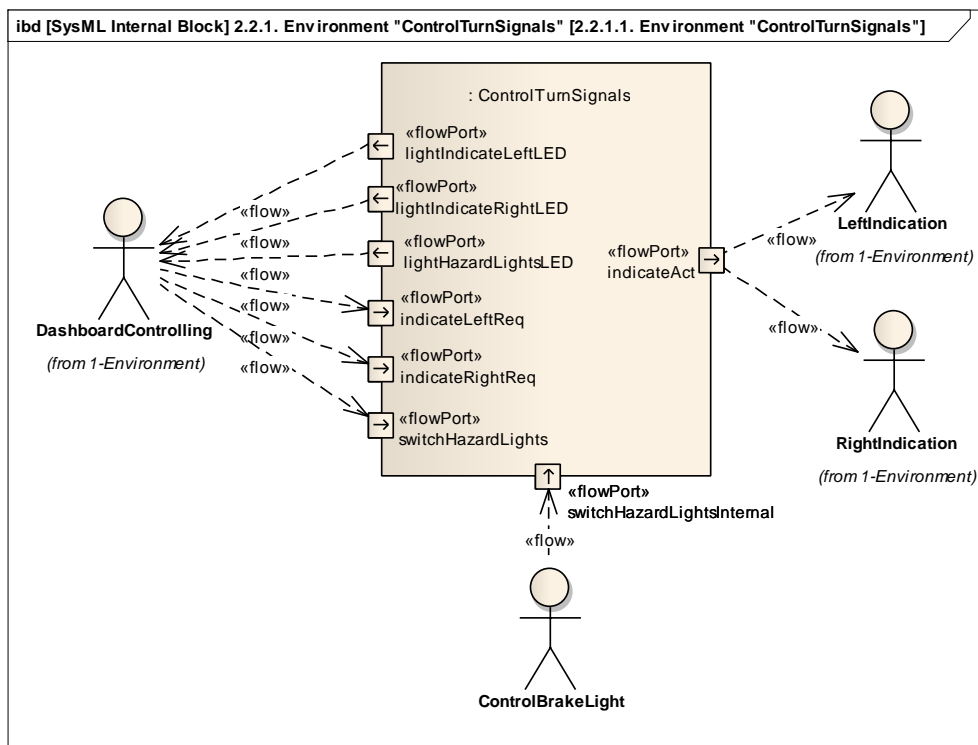

Figure 14: Environment of the subsystem *ControlTurnSignals* on the Subsystem Layer

As one can see on the example of the subsystem *ControlTurnSignals*, the interface of the complete system *BodyControlModule* covering the messages w.r.t. turn signals is partitioned onto this specific subsystem. Accordingly, further signals covered by the complete system interface that are related to other subsystems are partitioned onto these subsystems in the following. This method enables to focus on implementing one concrete atomic function at the end of the requirements engineering process.

Figure 15 shows the environment model of the subsystem *ControlBrakeLight*. Analogously to the environment model for the subsystem *ControlTurnSignals*, only the signals w.r.t. the brake lights are considered. Thus, *ControlBrakeLight* processes requests from the environment function *BrakePedalLevelSensing* and creates signals for the environment function *BrakeLightSwitching*. As specified in the environment model of *ControlTurnSignals* (cf. Figure 14), *BrakeLightSwitching* can communicate with this subsystem in order to request the activation of the hazard lights.

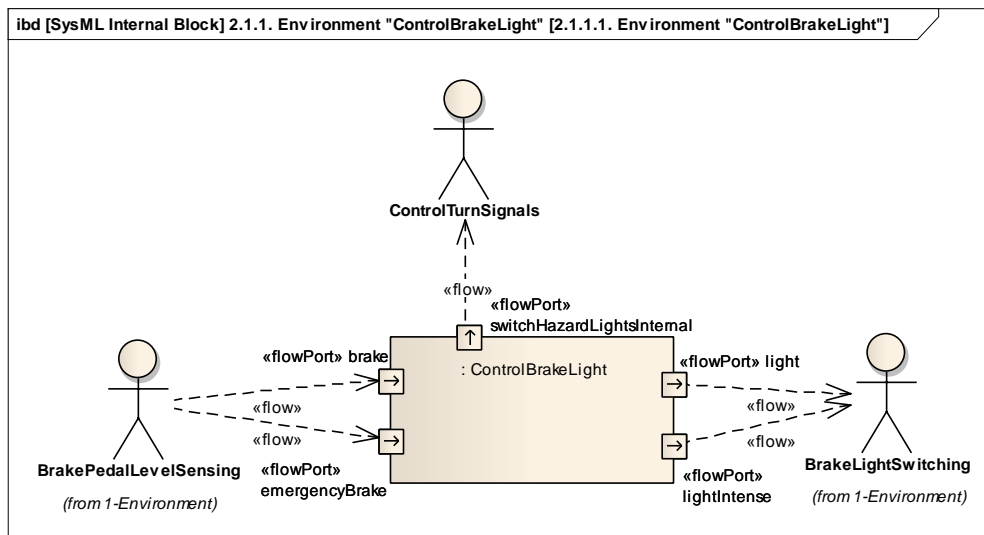

Figure 15: Environment of the subsystem *ControlBrakeLight* on the Subsystem Layer

Finally, Figure 16 describes the environment of the subsystem *HandleLampDefect*. The environment functions *LeftIndication*, *RightIndication*, and *BrakeLightSwitching* can communicate possible lamp defects to this subsystem, which can indicate this to the driver by communicating with the environment function *DashboardControlling*.

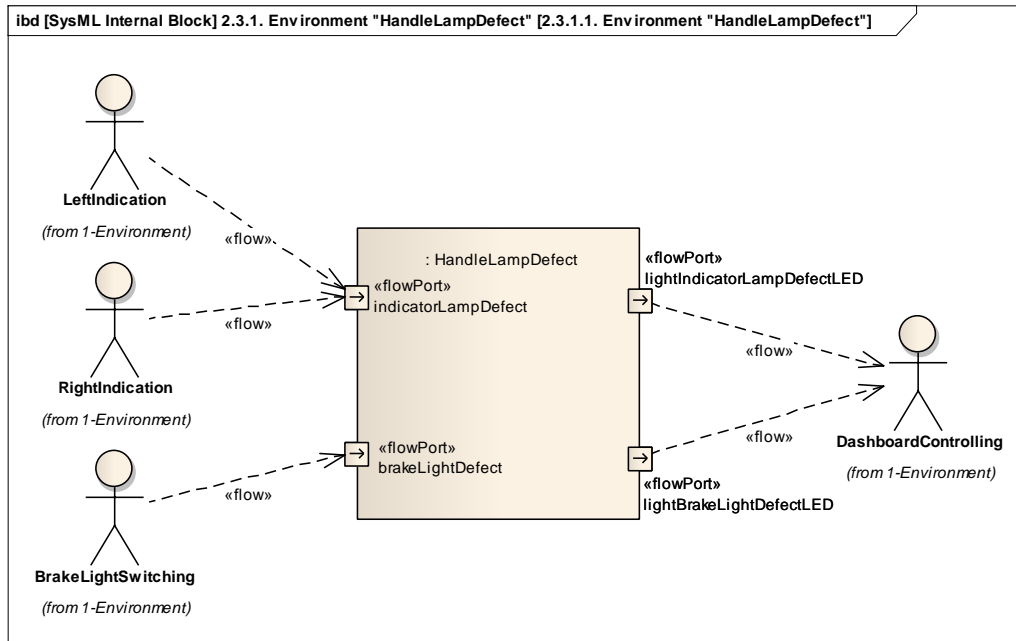

Figure 16: Environment of the subsystem *HandleLampDefect* on the Subsystem Layer

6.2.2 Refined Goals on the Subsystem Layer

In this example, the goals from the complete system layer are not refined any further.

6.2.3 Refined Scenarios on the Subsystem Layer

After the complete system *BodyControlModule* has been decomposed into three subsystems (cf. Section 6.1.4) and their interfaces and environment have been detailed (cf. Section 6.2.1), the corresponding scenarios have to be refined, too.

Figure 17 presents the scenario *Emergency brake light controlling*, which is derived from the scenario *Emergency brake light controlling* on the complete system layer (cf. Figure 10), the functional decomposition of the complete system into subsystems as input for this subsystem layer (cf. Section 6.2.4), and the environment description on this layer (cf. Section 6.2.1). It visualizes the planned interaction of the system functions *ControlBrakeLight* and *ControlTurnSignals* with their environment. It serves as a basis for the further decomposition of the function hierarchy (cf. Section 6.2.4).

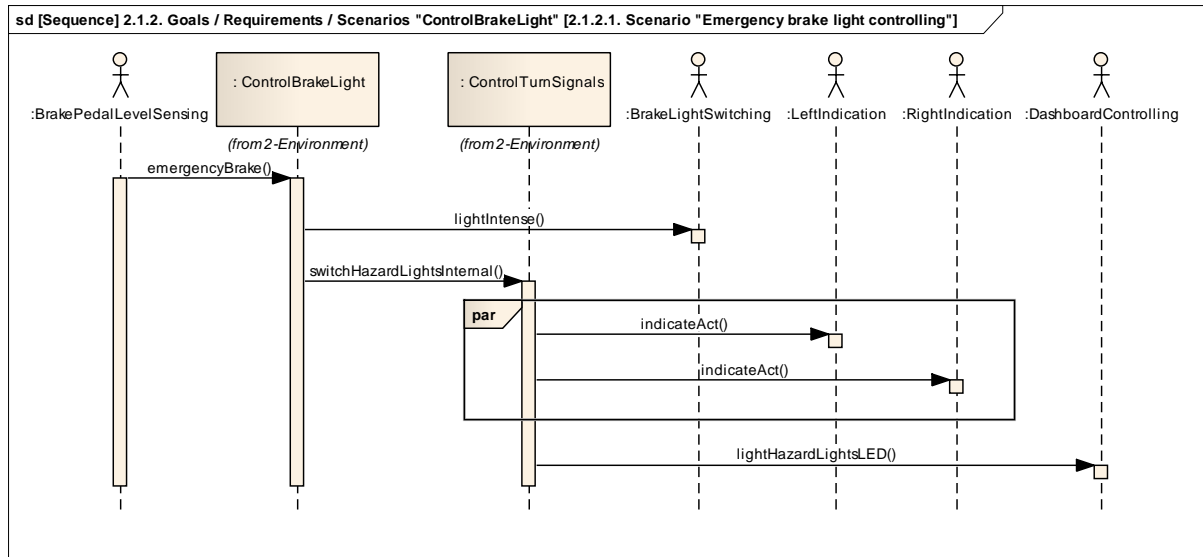

Figure 17: Scenario *Emergency brake light controlling* on the Subsystem Layer

The complete system *BodyControlModule* was decomposed into the subsystems *ControlBrakeLight* and *ControlTurnSignals*, among other things. Thus, this has to be reflected in all scenarios on the subsystem layer. Therefore, the lifeline *:BodyControlModule* from the scenario *Emergency brake light controlling* on the complete system layer (cf. Figure 10) are replaced by the lifelines *:ControlBrakeLight* and *:ControlTurnSignals* in the corresponding scenario on the subsystem layer. The messages are specified according to the interface specification as seen in the environment model (cf. Figure 14 and Figure 15). By partitioning the complete system into subsystems, internal messages between these subsystems are specified on this layer: The message *switchHazardLightsInternal* is exchanged between the two subsystems *ControlBrakeLight* and *ControlTurnSignals*, before further messages are sent to the environment functions. This interaction was not obvious in the corresponding scenario on the complete system layer (cf. Figure 10).

6.2.4 Function Hierarchy on the Subsystem Layer

After the interfaces of the complete system have been partitioned onto the subsystems and their feasibility has been validated by means of accordingly refined scenarios, these interfaces can be transferred to the function hierarchy.

As a first step towards this, we specify a white box view on the interior of the complete system *BodyControlModule* as depicted in Figure 18. The Internal Block Diagram jointly depicts the subsystems *ControlTurnSignals*, *ControlBrakeLight*, and *HandleLampDefect* as specified in the environment models of this layer (cf. Section 6.3.1). In this view, also the internal connections between the systems can be seen, that is, the internal signal *switchHazardLightsInternal*.

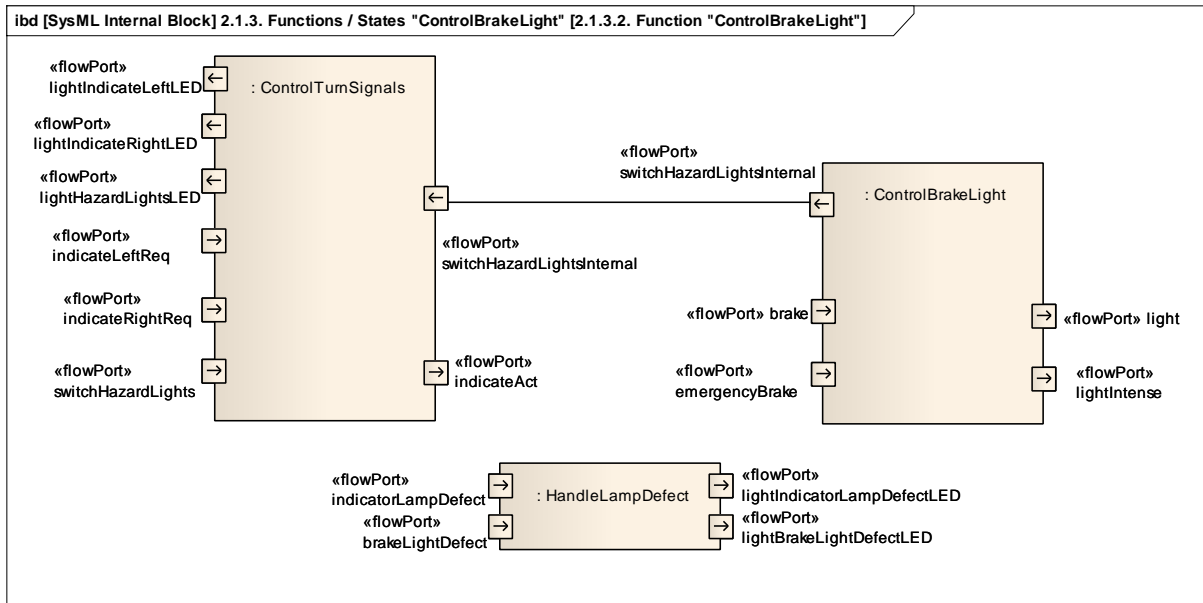

Figure 18: Functional Interaction between the subsystems on the Subsystem Layer

The resulting function hierarchy is depicted in Figure 19, where the subsystems *ControlTurnSignals*, *ControlBrakeLight* and *HandleLampDefect* now have a signal interface specified, which stems from the environment model and was validated by means of the scenarios.

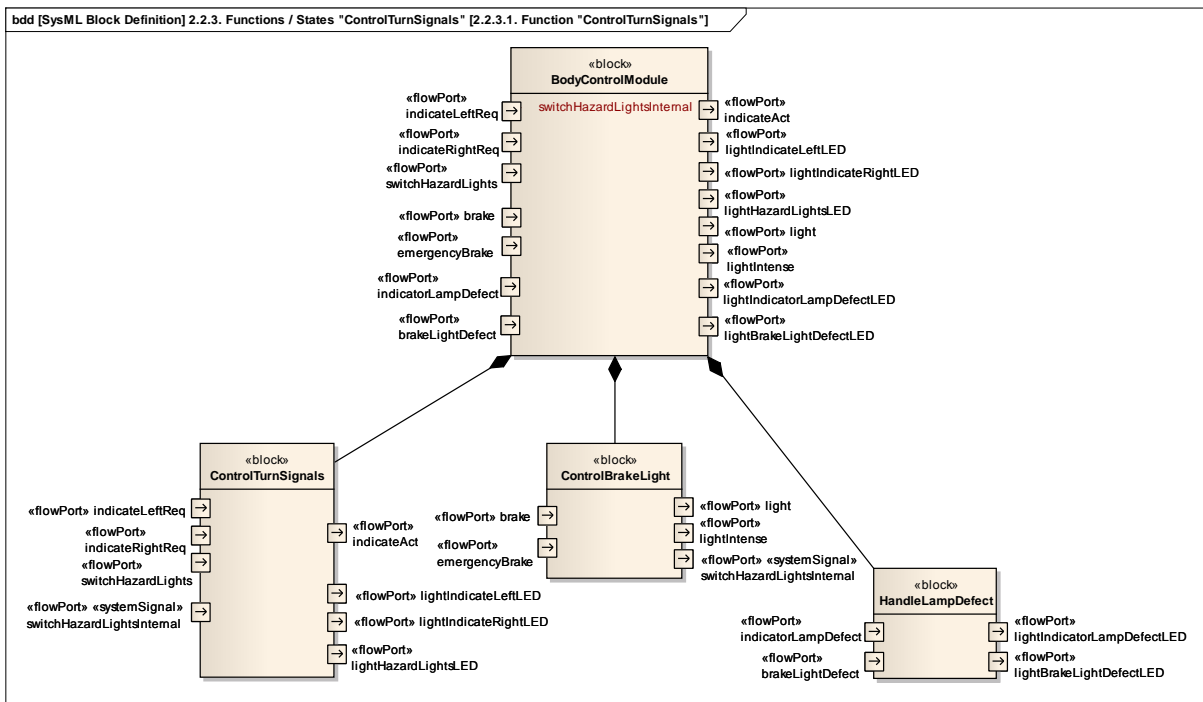

Figure 19: Final Functional Hierarchy on the Subsystem Layer

As next step, the function hierarchy is further decomposed as depicted in Figure 20. The system *ControlTurnSignals* is decomposed into the partial functionalities for the conventional turn signal control (*Indicate*) and the control of the hazard lights (*SwitchHazardLights*), the

system *ControlBrakeLights* is decomposed into the control of the conventional brake lights as well as the signalization of an emergency brake, and the system *HandleLampDefect* is partitioned into the handling of turn signal (*HandleIndicatorDefect*) and brake light lamp defects (*HandleBrakeLightDefect*). This state of the function hierarchy again serves as input for the next abstraction layer.

Note, that these subsystems are atomic functions that are not further decomposed, but this will be decided not until the corresponding decomposition step on the next abstraction layer (cf. Section 6.3.4). Nevertheless, we will speak in the following of functions to avoid confusion.

6.2.5 Solution-oriented Requirements

In this case study, solution-oriented requirements are only added on the function layer.

6.2.6 Requirement Pattern Representation of Function Hierarchy on Subsystem Layer

Before the functionality of the subsystem layer is decomposed in the next layer of abstraction, a switch to the natural-language-based requirement specification could be performed. The resulting requirement pattern instances are listed below (faded text stems from the complete system layer, cf. Section 6.1.6).

- The system *BodyControlModule* processes the following signals: *indicateLeftReq*, *indicateRightReq*, *switchHazardLights*, *brake*, *emergencyBrake*, *indicatorLampDefect*, *brakeLightDefect*.
- The system *BodyControlModule* creates the following signals: *indicateAct*, *lightIndicateLeftLED*, *lightIndicateRightLED*, *lightHazardLightsLED*, *light*, *lightIntense*, *switchHazardLights*, *lightIndicatorLampDefectLED*, *lightBrakeLightDefectLED*.
- The system *BodyControlModule* consists of the following subsystems: *ControlTurnSignals*, *ControlBrakeLight*, *HandleLampDefect*.
- The system *ControlTurnSignals* processes the following signals: *indicateLeftReq*, *indicateRightReq*, *switchHazardLights*.
- The system *ControlTurnSignals* creates the following signals: *indicateAct*, *lightIndicateLeftLED*, *lightIndicateRightLED*, *lightHazardLightsLED*.
- The system *ControlBrakeLight* processes the following signals: *brake*, *emergencyBrake*.
- The system *ControlBrakeLight* creates the following signals: *light*, *lightIntense*, *switchHazardLights*.
- The system *HandleLampDefect* processes the following signals: *indicatorLampDefect*, *brakeLightDefect*.
- The system *HandleLampDefect* creates the following signals: *lightIndicatorLampDefectLED*, *lightBrakeLightDefectLED*.
- The functionality of the system *ControlTurnSignals* consists of the following functions: *Indicate*, *SwitchHazardLights*.

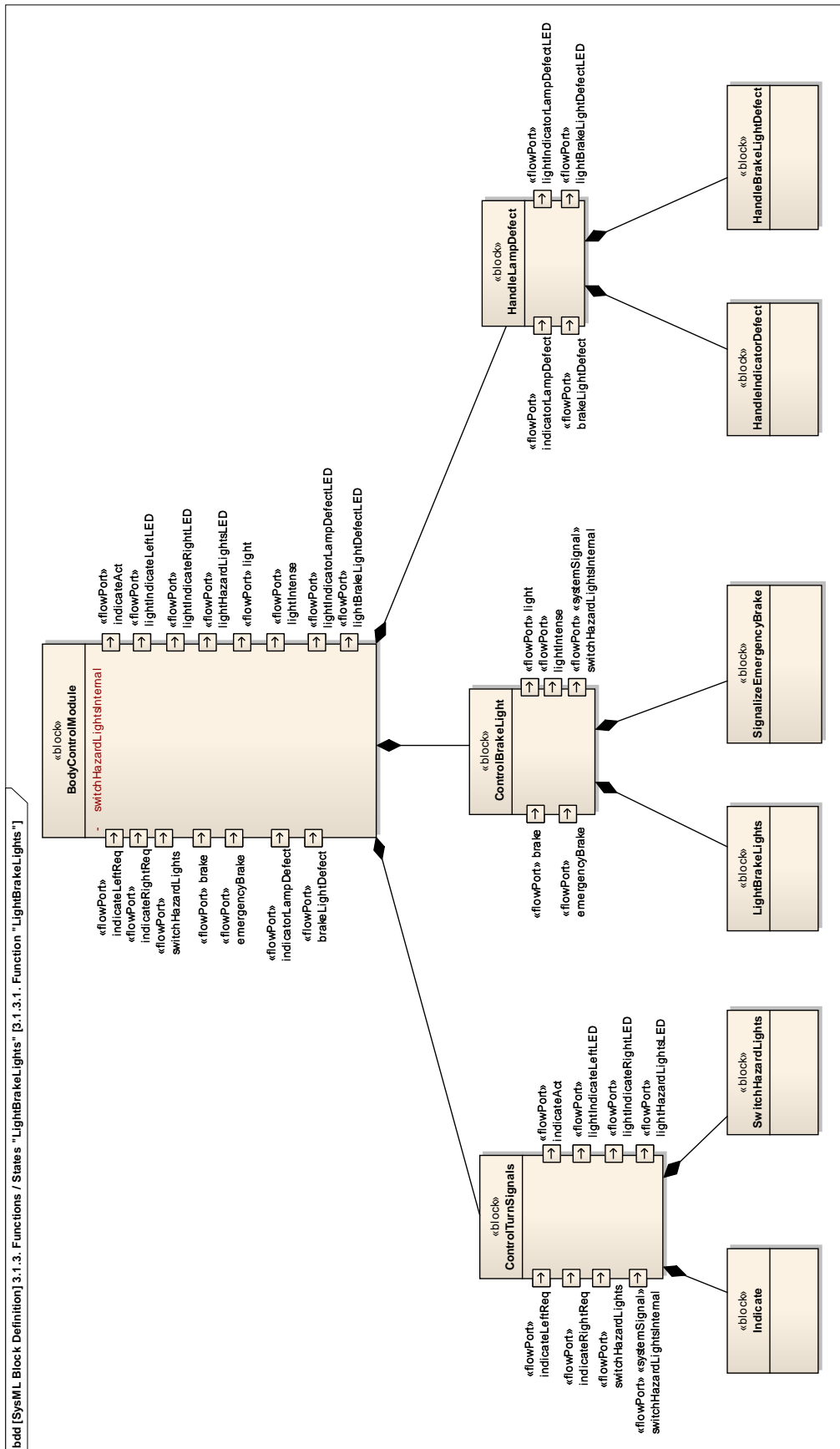

Figure 20: Initial Function Hierarchy on the Function Layer

- The functionality of the system *ControlBrakeLight* consists of the following functions: *LightBrakeLights*, *SignalizeEmergencyBrake*.
- The functionality of the system *HandleLampDefect* consists of the following functions: *HandleIndicatorDefect*, *HandleBrakeLightDefect*.

6.3 Function Layer

When all relevant stakeholders have a sufficient comprehension of the partial functionalities of the SUD, then it is not necessary to further decompose the function hierarchy. In this case, we call the subsystems on the lowest layer sufficiently trivial. Thus, these subsystems describe atomic functions that serve as basis for the subsequent architecture design.

6.3.1 Limited Environment on the Function Layer

As in the superordinate layer, we further partition the signal interfaces of the subsystems onto the contained functions in this step.

Figure 21 shows the environment of the function *SwitchHazardLights*. In contrast to the environment of the superordinate subsystem *ControlTurnSignals*, the ingoing flow *switchHazardLightsInternal* is now sent by the function *SignalizeEmergencyBrake* that is a function of the system *ControlBrakeLights*. Furthermore, the size of the input and output interface of *SwitchHazardLights* is reduced drastically in contrast to the superordinate system *ControlTurnSignals*. This shows the benefit of refining the function hierarchy and partitioning the overall signal interface of the complete system onto function interfaces that are easy to handle due to their reduced size.

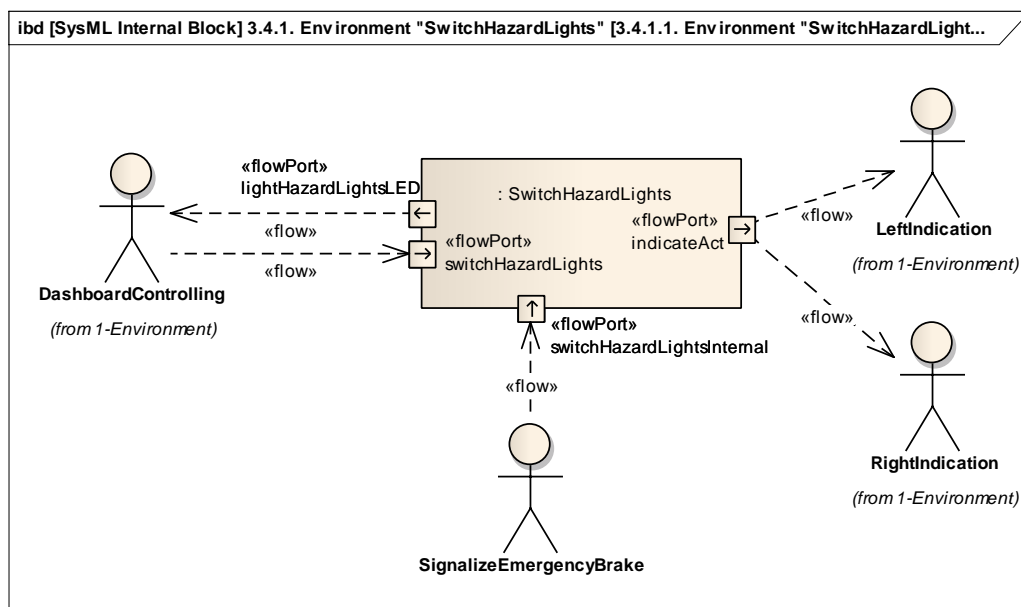

Figure 21: Environment of the Function *SwitchHazardLights* on the Function Layer

Figure 22 shows the environment model of the function *SignalizeEmergencyBrake*. According to the environment model of *SwitchHazardLights*, the signal *switchHazardLightsInternal* is now

sent to this function instead of its superordinate system. Apart from that, the interface size was reduced for this function, as well.

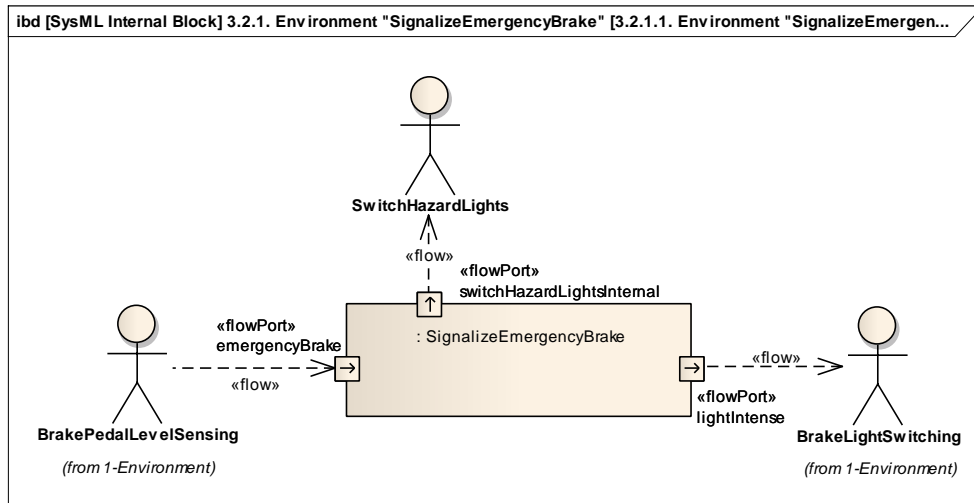

Figure 22: Environment of the Function *SignalizeEmergencyBrake* on the Function Layer

The other environment models are specified accordingly.

6.3.2 Refined Goals on the Function Layer

In this example, the goals from the complete system layer are not refined any further.

6.3.3 Refined Scenarios on the Function Layer

Figure 23 depicts the scenario *Emergency brake light controlling* on function layer. It is the refinement of the scenario on subsystem layer (cf. Section 6.2.3): The subsystem lifelines *ControlBrakeLight* and *ControlIndicators* were decomposed into the atomic functions *SignalizeEmergencyBrake* and *SwitchHazardLights*.

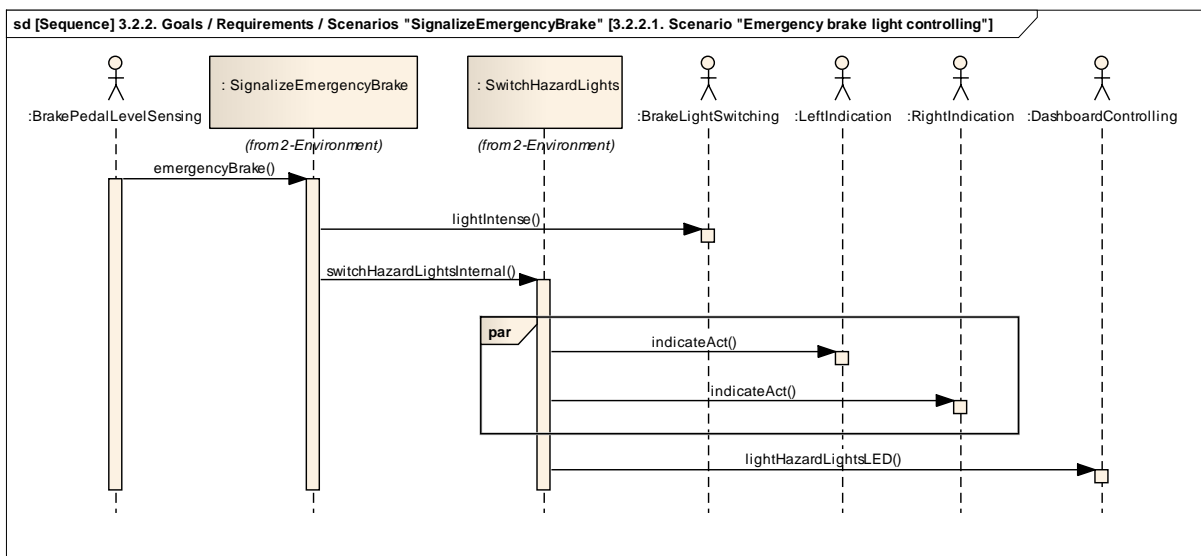

Figure 23: Scenario *Emergency brake light controlling* on Function Layer

6.3.4 Function Hierarchy on the Function Layer

As a result from the initial function hierarchy for this layer (cf. Figure 20) and the partition of the signal interfaces in the subsequent step of limiting the environment (cf. Section 6.3.1), Figure 24 shows the final function hierarchy. Since the partial functionalities on this layer are sufficiently trivial for all stakeholders and their interfaces are easy to handle, we decompose them not any further and consider them as atomic functions. These functions have to be fulfilled by components of the architecture to be designed in the subsequent development process.

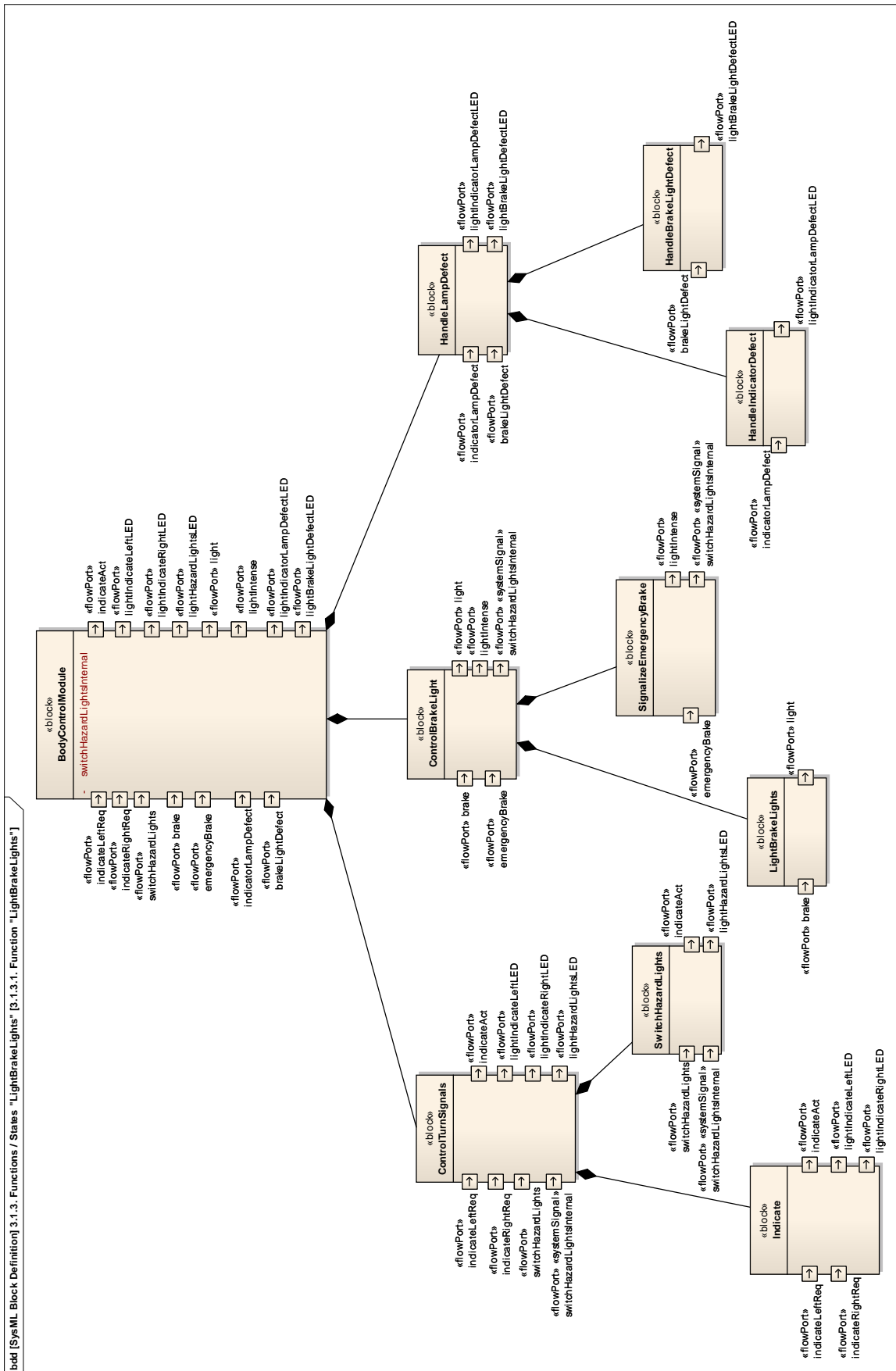

Figure 24: Final function hierarchy

6.3.5 Solution-oriented Requirements on the Function Layer

One class of solution-oriented requirements consists of timing requirements. For example, it is crucial for the function *SignalizeEmergencyBrake* that it requests an intense brake light from the external environment function *BrakeLightSwitching* within at most 25ms after an emergency braking has been detected.

We use the Timing Augmented Description Language (TADL, see [Johansson et al. 2009] and [Stappert et al. 2010]) to add timing constraints to our function models. Figure 25 depicts the above mentioned requirement in terms of a delay constraint on a so-called event chain between any events that can occur at the ports *emergencyBrake* and *lightIntense*. Logical components that implement the function *SignalizeEmergencyBrake* have to fulfill this timing requirement.

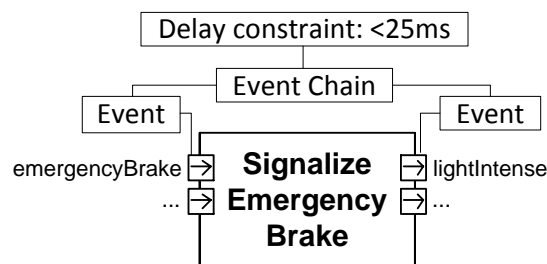

Figure 25: Timing requirement in model-based representation

Besides the function hierarchy, we count such solution-oriented requirements also to an artifact class that has to be exchanged with multiple stakeholders. Thus, we provide patterns and model transformations for solution-oriented requirements, as well. The representation in natural language according to requirement patterns (cf. requirement pattern no. 5 in Section 3.2) looks like this (cf. Table 1 in Section 3.2, requirement R8):

- The function *SignalizeEmergencyBrake* has to react within 25 ms to its stimuli.

6.3.6 Requirement Pattern Representation of Solution-oriented Requirement and Function Hierarchy on Function Layer

A final switch to the natural-language based requirement specification would result in the following requirement pattern instances (faded text stems from the last iteration, cf. Section 6.2.6):

- The system *BodyControlModule* processes the following signals: *indicateLeftReq*, *indicateRightReq*, *switchHazardLights*, *brake*, *emergencyBrake*, *indicatorLampDefect*, *brakeLightDefect*.
- The system *BodyControlModule* creates the following signals: *indicateAct*, *lightIndicateLeftLED*, *lightIndicateRightLED*, *lightHazardLightsLED*, *light*, *lightIntense*, *switchHazardLights*, *lightIndicatorLampDefectLED*, *lightBrakeLightDefectLED*.
- The system *BodyControlModule* consists of the following subsystems: *ControlTurnSignals*, *ControlBrakeLight*, *HandleLampDefect*.

- The system *ControlTurnSignals* processes the following signals: *indicateLeftReq*, *indicateRightReq*, *switchHazardLights*.
- The system *ControlTurnSignals* creates the following signals: *indicateAct*, *lightIndicateLeftLED*, *lightIndicateRightLED*, *lightHazardLightsLED*.
- The system *ControlBrakeLight* processes the following signals: *brake*, *emergencyBrake*.
- The system *ControlBrakeLight* creates the following signals: *light*, *lightIntense*, *switchHazardLights*.
- The system *HandleLampDefect* processes the following signals: *indicatorLampDefect*, *brakeLightDefect*.
- The system *HandleLampDefect* creates the following signals: *lightIndicatorLampDefectLED*, *lightBrakeLightDefectLED*.
- The functionality of the system *ControlTurnSignals* consists of the following functions: *Indicate*, *SwitchHazardLights*.
- The functionality of the system *ControlBrakeLight* consists of the following functions: *LightBrakeLights*, *SignalizeEmergencyBrake*.
- The functionality of the system *HandleLampDefect* consists of the following functions: *HandleIndicatorDefect*, *HandleBrakeLightDefect*.
- The function *SignalizeEmergencyBrake* has to react within 25 ms to its stimuli.
- The function *Indicate* processes the following signals: *indicateLeftReq*, *indicateRightReq*.
- The function *Indicate* creates the following signals: *indicateAct*, *lightIndicateLeftLED*, *lightIndicateRightLED*.
- The function *SwitchHazardLights* processes the following signals: *switchHazardLights*.
- The function *SwitchHazardLights* creates the following signals: *indicateAct*, *lightHazardLightsLED*.
- The function *LightBrakeLights* processes the following signals: *brake*.
- The function *LightBrakeLights* creates the following signals: *light*.
- The function *SignalizeEmergencyBrake* processes the following signals: *emergencyBrake*.
- The function *SignalizeEmergencyBrake* creates the following signals: *lightIntense*, *switchHazardLights*.
- The function *HandleIndicatorDefect* processes the following input signals: *indicatorLampDefect*.
- The function *HandleIndicatorDefect* creates the following signals: *lightIndicatorLampDefectLED*.
- The function *HandleBrakeLightDefect* processes the following signals: *brakeLightDefect*.
- The function *HandleBrakeLightDefect* creates the following signals: *lightBrakeLightDefectLED*.

7 Conclusions and Future Work

Natural language is the most common documentation format for requirements in the development of today's embedded systems [Juristo et al. 2002, Pretschner et al. 2007]. However, because of the inherent ambiguity of natural language, the volume of textually documented requirements in many systems, and the difficulty handling system complexity and requirements traceability, the use of model-based requirements documentation has been advocated [Sikora et al. 2012]. Yet, since requirements often build the basis for contractual agreements between suppliers and OEMs and due to missing methodical guidelines on when to apply models during system development, models are rarely applied in practice [Sikora et al. 2011]. We have developed a combined requirements engineering approach based on controlled natural language [Holtmann et al. 2011b] and the requirements viewpoint of the SPES Modeling Framework [Daun et al. 2012] in order to combine the advantages of model-based requirements documentation and natural language-based requirements documentation. By making use of this combined approach, it is possible to elicit and document requirements continuously and trace requirements from origin to their model-based manifestation in a function hierarchy.

We have applied the combined approach to a real-world industrial case study from the automotive industry, that is, a Body Control Module, which presents a new paradigm in automotive control unit interaction. The case study showed that the combined approach can be applied to automotive systems and supports the engineering of requirements consistently across multiple abstraction layers. It can be seen from the case study how context models and goal models can be used in early requirements engineering phases and be refined using scenarios. The resulting function hierarchy can be used in following phases of a model-based development process as a basis for the conception of the architecture of the SUD. Furthermore, the textual requirement pattern representation can be used as basis for legal documents exchanged with the customer or for document-oriented, intermediate reviews.

This work hence does not only provide a benefit for the integrated development using both model-based and natural language-based requirements specifications, but also shows how system requirements and a function hierarchy can be co-developed and hence shows how a transition from the requirements viewpoint to the functional viewpoint of the SPES Modeling Framework [Vogelsang et al. 2012] can be performed. However, given that this transition is not complete (cf. [Daun et al. 2012, Vogelsang et al. 2012]), future work will address how the transition between these viewpoints can be improved, and how with the aid of model-based requirements and controlled natural language related development activities, for example, safety engineering, artifact validation, or functional analysis, can be integrated.

References

- [Ambiola and Gervasi 1997] V. Ambriola, V. Gervasi: Processing Natural Language Requirements. In: Proceedings of the 12th IEEE International Conference on Automated Software Engineering, 1997.
- [Ambiola and Gervasi 2006] V. Ambriola, V. Gervasi: On the Systematic Analysis of Natural Language Requirements with CIRCE. In: Proceedings of the International Conference on Automated Software Engineering, 2006.
- [AutomotiveSIG 2010] Automotive Special Interest Group (SIG): Automotive SPICE. Process Reference Model. http://www.automotivespice.com/automotiveSIG_PRM_v45.pdf. Accessed on: June 7th, 2012.
- [Balzert 2009] H. Balzert: Lehrbuch der Softwaretechnik: Basiskonzepte und Requirements Engineering, 3rd Edition, Spektrum Akademischer Verlag, Heidelberg, 2003.
- [Braun et al. 2010] P. Braun, M. Broy, F. Houdek, M. Kirchmayr, M. Müller, B. Penzenstadler, K. Pohl, T. Weyer: Guiding requirements engineering for software-intensive embedded systems in the automotive industry. Computer Science Research and Development, Springer, Heidelberg, 2010, DOI: 10.1007/s00450-010-0136-y
- [Bühne et al. 2004] S. Bühne, G. Halmans, K. Pohl, M. Weber, H. Kleinwechter, T. Wierzoch: Defining requirements at different levels of abstraction. In: Proceedings of the 12th IEEE International Requirements Engineering Conference, 2004.
- [Daun et al. 2012] M. Daun, B. Tenbergen, T. Weyer: Requirements Viewpoint. In: K. Pohl, H. Hönniger, R. Achatz, M. Broy: Model-Based Engineering of Embedded Systems – The SPES 2020 Methodology. Springer, 2012.
- [Davis 1993] A. M. Davis: Software Requirements – Objects, Functions, States. 2nd Edition, Prentice Hall, Englewood Cliffs, New Jersey, 1993.
- [Davis 2005] A. Davis: Just Enough Requirements Engineering: Where Software Development Meets Marketing. Dorset House Publishing, New York, 2005.

- [Deeptimahanti and Barbar 2009] D. K. Deeptimahanti, M. A. Babar: An Automated Tool for Generating UML Models from Natural Language Requirements. In: Proceedings of the 24th IEEE/ACM International Conference on Automated Software Engineering, 2009.
- [Deeptimahanti and Sanyal 2011] D. K. Deeptimahanti, R. Sanyal: Semi-Automatic Generation of UML Models from Natural Language Requirements. In: Proceedings of the 4th India Software Engineering Conference, 2011.
- [DeMarco 1979] T. DeMarco: Structured Analysis and System Specification. Yourdon Press, Upper Saddle River, New Jersey, 1979.
- [Drusinsky 2008] D. Drusinsky: From UML Activity Diagrams to Specification Requirements. In: IEEE International Conference on System of Systems Engineering, 2008.
- [Fine 2002] K. Fine: The Limits of Abstraction. Oxford University Press, New York, 2002.
- [Flynn and Warhurst 1994] D. J. Flynn, R. Warhurst: An empirical study of the validation process within requirements determination. Information Systems Journal 4, 1994, pp. 185-212.
- [Fockel et al. 2012a] M. Fockel, J. Holtmann, J. Meyer: Semi-automatic Establishment and Maintenance of Valid Traceability in Automotive Development Processes. In: Proceedings of the 2nd International Workshop on Software Engineering for Embedded Systems, 2012.
- [Fockel et al. 2012b] M. Fockel, P. Heidl, J. Höfflinger, H. Hönninger, J. Holtmann, W. Horn, J. Meyer, M. Meyer, J. Schäuuffele: Application and Evaluation in the Automotive Domain. In: K. Pohl, H. Hönninger, R. Achatz, M. Broy: Model-Based Engineering of Embedded Systems – The SPES 2020 Methodology. Springer, 2012.
- [Gausemeier et al. 2009] J. Gausemeier; U. Frank; J. Donoth; S. Kahl: Specification technique for the description of self-optimizing mechatronic systems. Research in Engineering Design 20, 2009, pp. 201–223.
- [Goldsmith 2004] R. Goldsmith: Discovering Real Business Requirements for Software Project Success. Artech House, Boston, 2004.

- [Gotel and Finkelstein 1994] O. C. Z. Gotel, C. W. Finkelstein: An analysis of the requirements traceability problem. In: Proceedings of the 1st International Conference on Requirements Engineering, 1994.
- [Harmain and Gaizauskas 2000] H. M. Harmain, R. Gaizauskas: CM-Builder: An Automated NL-based CASE Tool. Proceedings of the 15th IEEE International Conference on Automated Software Engineering, 2000.
- [Harmain and Gaizauskas 2003] H. M. Harmain, R. Gaizauskas: CM-Builder: A Natural Language-Based CASE Tool for Object-Oriented Analysis. In: Automated Software Engineering 10(2), 2003, pp. 157–181
- [Holtmann 2010] J. Holtmann. Mit Satzmustern von textuellen Anforderungen zu Modellen. In: OBJEKTSpektrum RE/2010. (Online Themenspecial Requirements Engineering) http://www.sigs-datcom.de/fileadmin/user_upload/zeitschriften/os/2010/RE/holtmann_OS_RE_2010.pdf. Accessed on: June 7th, 2012.
- [Holtmann et al. 2011a] J. Holtmann, J. Meyer, M. Meyer: A Seamless Model-Based Development Process for Automotive Systems. In: Workshopband Software Engineering, Lecture Notes in Informatics Volume 184, Bonner Köllen Verlag, Bonn, 2011.
- [Holtmann et al. 2011b] J. Holtmann, J. Meyer, M. von Detten: Automatic Validation and Correction of Formalized, Textual Requirements. In: Proceedings of the 4th IEEE International Conference on Software Testing, Verification and Validation Workshops, 2011.
- [Huijsen 1998a] W.-O. Huijsen: Controlled Language – An Introduction. In: Proceedings of the 2nd International Workshop on Controlled Language Applications, 1998..
- [Huisen 1998b] W.-O. Huijsen: Completeness of Compositional Translation, Elinkwijk Drukkerij B.V., 1998.
- [IEEE 830] Institute of Electrical and Electronics Engineers: IEEE Std. 830-1998: IEEE Recommended Practice for Software Requirements Specifications, 1998.

- [Ilieva and Ormandjieva 2006] M. G. Ilieva, O. Ormandjieva: Models Derived from Automatically Analyzed Textual User Requirements. In: Proceedings of the 4th International Conference on Software Engineering Research, Management and Applications, 2006.
- [ISO 26262] International Organization for Standardization: ISO26262: Road Vehicles – Functional Safety, 2011.
- [Jersak et al. 2003] M. Jersak, K. Richter, R. Ernst, J. Braam, Z. Jiang, F. Wolf: Formal methods for integration of automotive software. In: Proceedings of the Design, Automation and Test in Europe Conference and Exhibition, 2003.
- [Johansson et al. 2009] R. Johansson; P. Frey; J. Jonsson; J. Nordlander; R. M. Pathan; N. Feiertag; M. Schlager; H. Espinoza; K. Richtter; St. Kuntz; H. Lönn; R. T. Kolagari; H. Blom: TADL: Timing Augmented Description Language Version 2. 2009.
- [Juristo et al. 2002] N. Juristo, A. Moreno, A. Silva: Is the European industry moving toward solving RE problems? IEEE Software 19(6), 2002, pp. 70–77.
- [Kapeller and Krause 2006] R. Kapeller, S. Krause: So natürlich wie Sprechen - Embedded Systeme modellieren. In: Design & Elektronik 08, 2006, pp. 64–67.
- [Kiyavitskaya and Zannone 2008] N. Kiyavitskaya, N. Zannone: Requirements Model Generation to Support Requirements Elicitation: The Secure Tropos Experience. Automated Software Engineering 15(2), 2008, pp. 149–173.
- [Kof 2009] L. Kof: Translation of Textual Specifications to Automata by Means of Discourse Context Modeling. In: Lecture Notes in Computer Science 5512, Springer, Heidelberg, 2009, pp. 197–211.
- [Kof 2010] L. Kof: From Requirements Documents to System Models: A Tool for Interactive Semi-Automatic Translation. In: Proceedings of the 18th IEEE International Requirements Engineering Conference, 2010.

- [Lu et al. 2007] C.-W. Lu, W. C. Chu, C.-H. Chang, C. H. Wang: A Model-Based Object-Oriented Approach to Requirement Engineering (MORE). In: Proceedings of the 1st International Computer Software and Applications Conference, 2007.
- [Lu et al. 2008a] C.-W. Lu, W. C. Chu, C.-H. Chang: Model-Based Object-Oriented Requirement Engineering and its Support to Software Documents Integration. In: Proceedings of the 2008 International Conference on Software Engineering Research and Practice, 2008.
- [Lu et al. 2008b] C.-W. Lu, C.-H. Chang, W. C. Chu, Y.-W. Cheng, H.-C. Chang: A Requirement Tool to Support Model-Based Requirement Engineering. In: Proceedings of the 2nd International Computer Software and Applications Conference, 2008.
- [Meziane et al. 2008] F. Meziane, N. Athanasakis, S. Ananiadou: Generating Natural Language Specifications from UML Class Diagrams. *Requirements Engineering* 13(1), 2008, pp. 1-18.
- [Mich et al. 2002] L. Mich, R. Garigliano, A. Zanasi, C. A. Brebbia, N. F. F. E. Ebecken, P. Melli: NL-OOPS: A Requirements Analysis Tool Based on Natural Language Processing. *Management Information Systems* 6, 2002, pp. 321–330.
- [Neill and Laplante 2003] C. Neill, P. Laplante: Requirements Engineering: the state of Practice. *IEEE Software* 20(4), 2003, pp. 40-45.
- [Nicolás and Toval 2009] J. Nicolás, A. Toval: On the Generation of Requirements Specifications from Software Engineering Models: A Systematic Literature Review. *Information and Software Technology* 51(9), 2009, pp. 1291-1307..
- [Nuseibeh 2001] B. Nuseibeh: Weaving together requirements and architectures. In: *IEEE Computer* 34(3), 2001, pp. 115-119.
- [OMG 2003] Object Management Group: MDA Guide, Version 1.0.1. OMG Document Number: omg/2003-06-01, 2003.
- [Pohl 2010] K. Pohl: *Requirements Engineering: Foundations, Principles, and Techniques*. Springer, Heidelberg, 2010.

- [Pohl and Sikora 2007] K. Pohl, E. Sikora: The Co-Development of System Requirements and Functional Architecture. In: J. Krogstie, A. Lothe Opdahl, S. Brinkkemper: Conceptual Modelling in Information Systems Engineering. Springer, Heidelberg, 2007.
- [Broy et al. 2012] M. Broy, W. Damm, S. Henkler, K. Pohl, A. Vogelsang, T. Weyer: Introduction to the SPES Modeling Framework. In: K. Pohl, H. Hönniger, R. Achatz, M. Broy: Model-Based Engineering of Embedded Systems – The SPES 2020 Methodology. Springer, 2012.
- [Vogelsang et al. 2012] A. Vogelsang, S. Eder, M. Feilkas, D. Ratiu: Functional Viewpoint. In: K. Pohl, H. Hönniger, R. Achatz, M. Broy: Model-Based Engineering of Embedded Systems – The SPES 2020 Methodology. Springer, 2012.
- [Potts 1995] C. Potts: Using schematic scenarios to understand user needs. In: Proceedings of the 1st Conference on Designing Interactive Systems: Processes, Practices, Methods, & Techniques, 1995.
- [Pretschner et al. 2007] A. Pretschner, M. Broy, I. Krüger, Th. Stauner: Software engineering for automotive systems: a roadmap. In: Proceedings of Future of Software Engineering, 2007.
- [Ross and Schoman 1977] D. T. Ross, K. E. Schoman: Structured Analysis for Requirements Definition. IEEE Transactions on Software Engineering SE-3(1), 1977, pp. 6 – 15.
- [Royce 1970] W. W. Royce: Managing the Development of Large Software Systems. In: Proceedings of IEEE WESCON, 1970, pp. 1-9.
- [Schäuffele and Zurawka 2003] J. Schäuffele, Th. Zurawka: Automotive Software Engineering – Grundlagen, Prozesse, Methoden und Werkzeuge. Vieweg, Wiesbaden, 2003.
- [Schürr 1995] A. Schürr: Specification of Graph Translators with Triple Graph Grammars. In: Graph-Theoretic Concepts in Computer Science. Springer, Heidelberg, 1995.
- [Schwitter 2010] R. Schwitter: Controlled natural languages for knowledge representation. In: Proceedings of the 23rd International Conference on Computational Linguistics: Posters, 2010.
- [Sikora et al. 2010] E. Sikora, M. Daun, K. Pohl: Supporting the Consistent Specification of Scenarios across Multiple Abstraction Levels. In: Proceedings of Requirements Engineering: Foundation for Software Quality, 2010.

- [Sikora et al. 2011] E. Sikora, B. Tenbergen, K. Pohl: Requirements engineering for embedded systems: An investigation of industry needs. In: Proceedings of Requirements Engineering: Foundation for Software Quality, 2011.
- [Sikora et al. 2012] E. Sikora, B. Tenbergen, K. Pohl: Industry Needs and Research Directions in Requirements Engineering for Embedded Systems. Requirements Engineering 17(1), 2012, pp. 57-78.
- [Stappert et al. 2010] F. Stappert; J. Jonsson; J. Mottok; R. Johansson: A Design Framework for End-To-End Timing Constrained Automotive Applications. In: Proceedings of the European Congress on Embedded Real-Time Software and Systems, 2010.
- [van Lamsweerde 2009] A. van Lamsweerde: Requirements Engineering: From System Goals to UML Models to Software Specifications. Wiley, Sussex, 2009.
- [Weber and Weisbrod 2003] M. Weber, J. Weisbrod: Requirements engineering in automotive development: Experiences and challenges. IEEE Software 20, 2003, pp. 16-24.
- [Weyer 2010] T. Weyer: Kohärenzprüfung von Verhaltensspezifikationen gegen spezifische Eigenschaften des operationellen Kontexts. Dissertation, University of Duisburg-Essen, Faculty for Business Information Systems, Essen, 2010.
- [Yue et al. 2011] T. Yue, L. Briand, Y. Labiche: A Systematic Review of Transformation Approaches between User Requirements and Analysis Models. Requirements Engineering 16(2), 2011, pp. 75–99.

Previously published ICB - Research Reports

2013

No 54 (March)

Fischotter, Melanie; Goedicke, Michael, Kurt-Karaoglu, Filiz; Schwinning, Nils; Striewe, Michael: "Erster Jahresbericht zum Projekt "Bildungsgerechtigkeit im Fokus" (Teilprojekt 1.2 – "Blended Learning") an der Fakultät für Wirtschaftswissenschaften

2012

No 53 (December)

Frank, Ulrich: "Thoughts on Classification / Instantiation and Generalisation / Specialisation"

No 52 (July 2012)

Berntsson Svennson, Richard; Berry, Daniel; Daneva, Maya; Dörr, Jörg; Frickler, Samuel A.; Herrmann, Andrea; Herzwurm, Georg; Kauppinen, Marjo; Madhavji, Nazim H.; Mahaux, Martin; Paech, Barbara; Penzenstadler, Birgit; Pietsch, Wolfram; Salinesi, Camile; Schneider, Kurt; Seyff, Norbert; van de Weerd, Inge (Eds): "18th International Working Conference on Requirements Engineering: Foundation for Software Quality. Proceedings of the Workshops Re4SuSy, REEW, CreaRE, RePriCo, IWSPM and the Conference Related Empirical Study, Empirical Fair and Doctoral Symposium"

No 51 (May)

Frank, Ulrich: "Specialisation in Business Process Modelling: Motivation, Approaches and Limitations"

No 50 (March)

Adelsberger, Heimo; Drechsler, Andreas; Herzig, Eric; Michaelis, Alexander; Schulz, Philipp; Schütz, Stefan; Ulrich, Udo: "Qualitative und quantitative Analyse von SOA-Studien – Eine Metastudie zu serviceorientierten Architekturen"

2011

No 49 (December 2011)

Frank, Ulrich: "MEMO Organisation Modelling Language (2): Focus on Business Processes"

No 48 (December 2011)

Frank, Ulrich: "MEMO Organisation Modelling Language (1): Focus on Organisational Structure"

No 47 (December 2011)

Frank, Ulrich: "MEMO Organisation Modelling Language (OrgML): Requirements and Core Diagram Types"

No 46 (December 2011)

Frank, Ulrich: "Multi-Perspective Enterprise Modelling: Background and Terminological Foundation"

No 45 (November 2011)

Frank, Ulrich; Strecker, Stefan; Heise, David; Kattenstroth, Heiko; Schauer, Carola: "Leitfaden zur Erstellung wissenschaftlicher Arbeiten in der Wirtschaftsinformatik"

No 44 (September 2010)

Berenbach, Brian; Daneva, Maya; Dörr, Jörg; Frickler, Samuel; Geroasi, Vincenzo; Glinz, Martin; Herrmann, Andrea; Krams, Benedikt; Madhavji, Nazim H.; Paech, Barbara; Schockert, Sixten; Seyff, Norbert (Eds): "17th International Working Conference on Requirements Engineering: Foundation for Software Quality (REFSQ 2011). Proceedings of the REFSQ 2011 Workshops REEW, EPICAL and RePriCo, the REFSQ 2011 Empirical Track (Empirical Live Experiment and Empirical Research Fair), and the REFSQ 2011 Doctoral Symposium"

No 43 (February)

Frank, Ulrich: "The MEMO Meta Modelling Language (MML) and Language Architecture – 2nd Edition"

2010

No 42 (December)

Frank, Ulrich: "Outline of a Method for Designing Domain-Specific Modelling Languages"

No 41 (December)

Adelsberger, Heimo; Drechsler, Andreas (Eds): "Ausgewählte Aspekte des Cloud-Computing aus einer IT-Management-Perspektive – Cloud Governance, Cloud Security und Einsatz von Cloud Computing in jungen Unternehmen"

No 40 (October 2010)

Bürsner, Simone; Dörr, Jörg; Gehlert, Andreas; Herrmann, Andrea; Herzwurm, Georg; Janzen, Dirk; Merten, Thorsten; Pietsch, Wolfram; Schmid, Klaus; Schneider, Kurt; Thurimella, Anil Kumar (Eds): "16th International Working Conference on Requirements Engineering: Foundation for Software Quality. Proceedings of the Workshops CreaRE, PLREQ, RePriCo and RESC"

No 39 (May 2010)

Strecker, Stefan; Heise, David; Frank, Ulrich: "Entwurf einer Mentoring-Konzeption für den Studiengang M.Sc. Wirtschaftsinformatik an der Fakultät für Wirtschaftswissenschaften der Universität Duisburg-Essen"

No 38 (February 2010)

Schauer, Carola: "Wie praxisorientiert ist die Wirtschaftsinformatik? Einschätzungen von CIOs und WI-Professoren"

No 37 (January 2010)

Benavides, David; Batory, Don; Grunbacher, Paul (Eds.): "Fourth International Workshop on Variability Modelling of Software-intensive Systems"

2009

No 36 (December 2009)

Strecker, Stefan: "Ein Kommentar zur Diskussion um Begriff und Verständnis der IT-Governance - Anregungen zu einer kritischen Reflexion"

No 35 (August 2009)

Rüngeler, Irene; Tüxen, Michael; Rathgeb, Erwin P.: "Considerations on Handling Link Errors in STCP"

No 34 (June 2009)

Karastoyanova, Dimka; Kazhamiakan, Raman; Metzger, Andreas; Pistore, Marco (Eds.): "Workshop on Service Monitoring, Adaption and Beyond"

No 33 (May 2009)

Adelsberger, Heimo; Drechsler, Andreas; Bruckmann, Tobias; Kalvelage, Peter; Kinne, Sophia; Pellingner, Jan; Rosenberger, Marcel; Trepper, Tobias: „Einsatz von Social Software in Unternehmen – Studie über Umfang und Zweck der Nutzung“

No 32 (April 2009)

Barth, Manfred; Gadatsch, Andreas; Kütz, Martin; Rüdiger, Otto; Schauer, Hanno; Strecker, Stefan: „Leitbild IT-Controller/-in – Beitrag der Fachgruppe IT-Controlling der Gesellschaft für Informatik e. V.“

No 31 (April 2009)

Frank, Ulrich; Strecker, Stefan: "Beyond ERP Systems: An Outline of Self-Referential Enterprise Systems – Requirements, Conceptual Foundation and Design Options"

No 30 (February 2009)

Schauer, Hanno; Wolff, Frank: „Kriterien guter Wissensarbeit – Ein Vorschlag aus dem Blickwinkel der Wissenschaftstheorie (Langfassung)“

No 29 (January 2009)

Benavides, David; Metzger, Andreas; Eisenecker, Ulrich (Eds.): "Third International Workshop on Variability Modelling of Software-intensive Systems"

2008

No 28 (December 2008)

Goedicke, Michael; Striewe, Michael; Balz, Moritz: „Computer Aided Assessments and Programming Exercises with JACK“

No 27 (December 2008)

Schauer, Carola: "Größe und Ausrichtung der Disziplin Wirtschaftsinformatik an Universitäten im deutschsprachigen Raum - Aktueller Status und Entwicklung seit 1992"

No 26 (September 2008)

Milen, Tilev; Bruno Müller-Clostermann: " CapSys: A Tool for Macroscopic Capacity Planning"

No 25 (August 2008)

Eicker, Stefan; Spies, Thorsten; Tschersich, Markus: "Einsatz von Multi-Touch beim Softwaredesign am Beispiel der CRC Card-Methode"

No 24 (August 2008)

Frank, Ulrich: "The MEMO Meta Modelling Language (MML) and Language Architecture – Revised Version"

No 23 (January 2008)

Sprenger, Jonas; Jung, Jürgen: "Enterprise Modelling in the Context of Manufacturing – Outline of an Approach Supporting Production Planning"

No 22 (January 2008)

Heymans, Patrick; Kang, Kyo-Chul; Metzger, Andreas, Pohl, Klaus (Eds.): "Second International Workshop on Variability Modelling of Software-intensive Systems"

2007

No 21 (September 2007)

Eicker, Stefan; Annett Nagel; Peter M. Schuler: "Flexibilität im Geschäftsprozess-management-Kreislauf"

No 20 (August 2007)

Blau, Holger; Eicker, Stefan; Spies, Thorsten: "Reifegradüberwachung von Software"

No 19 (June 2007)

Schauer, Carola: "Relevance and Success of IS Teaching and Research: An Analysis of the 'Relevance Debate'"

No 18 (May 2007)

Schauer, Carola: "Rekonstruktion der historischen Entwicklung der Wirtschaftsinformatik: Schritte der Institutionalisierung, Diskussion zum Status, Rahmenempfehlungen für die Lehre"

No 17 (May 2007)

Schauer, Carola; Schmeing, Tobias: "Development of IS Teaching in North-America: An Analysis of Model Curricula"

No 16 (May 2007)

Müller-Clostermann, Bruno; Tilev, Milen: "Using G/G/m-Models for Multi-Server and Mainframe Capacity Planning"

No 15 (April 2007)

Heise, David; Schauer, Carola; Strecker, Stefan: "Informationsquellen für IT-Professionals – Analyse und Bewertung der Fachpresse aus Sicht der Wirtschaftsinformatik"

No 14 (March 2007)

Eicker, Stefan; Hegmanns, Christian; Malich, Stefan: "Auswahl von Bewertungsmethoden für Softwarearchitekturen"

No 13 (February 2007)

Eicker, Stefan; Spies, Thorsten; Kahl, Christian: "Softwarevisualisierung im Kontext serviceorientierter Architekturen"

No 12 (February 2007)

Brenner, Freimut: "Cumulative Measures of Absorbing Joint Markov Chains and an Application to Markovian Process Algebras"

No 11 (February 2007)

Kirchner, Lutz: "Entwurf einer Modellierungssprache zur Unterstützung der Aufgaben des IT-Managements – Grundlagen, Anforderungen und Metamodell"

No 10 (February 2007)

Schauer, Carola; Strecker, Stefan: "Vergleichende Literaturstudie aktueller einführender Lehrbücher der Wirtschaftsinformatik: Bezugsrahmen und Auswertung"

No 9 (February 2007)

Strecker, Stefan; Kuckertz, Andreas; Pawlowski, Jan M.: "Überlegungen zur Qualifizierung des wissenschaftlichen Nachwuchses: Ein Diskussionsbeitrag zur (kumulativen) Habilitation"

No 8 (February 2007)

Frank, Ulrich; Strecker, Stefan; Koch, Stefan: "Open Model - Ein Vorschlag für ein Forschungsprogramm der Wirtschaftsinformatik (Langfassung)"

2006

No 7 (December 2006)

Frank, Ulrich: "Towards a Pluralistic Conception of Research Methods in Information Systems Research"

No 6 (April 2006)

Frank, Ulrich: "Evaluation von Forschung und Lehre an Universitäten – Ein Diskussionsbeitrag"

No 5 (April 2006)

Jung, Jürgen: "Supply Chains in the Context of Resource Modelling"

No 4 (February 2006)

Lange, Carola: "Development and status of the Information Systems / Wirtschaftsinformatik discipline: An interpretive evaluation of interviews with renowned researchers, Part III – Results Wirtschaftsinformatik Discipline"

2005

No 3 (December 2005)

Lange, Carola: "Development and status of the Information Systems / Wirtschaftsinformatik discipline: An interpretive evaluation of interviews with renowned researchers, Part II – Results Information Systems Discipline"

No 2 (December 2005)

Lange, Carola: "Development and status of the Information Systems / Wirtschaftsinformatik discipline: An interpretive evaluation of interviews with renowned researchers, Part I – Research Objectives and Method"

No 1 (August 2005)

Lange, Carola: „Ein Bezugsrahmen zur Beschreibung von Forschungsgegenständen und -methoden in Wirtschaftsinformatik und Information Systems“

Research Group	Core Research Topics
Prof. Dr. H. H. Adelsberger Information Systems for Production and Operations Management	E-Learning, Knowledge Management, Skill-Management, Simulation, Artificial Intelligence
Prof. Dr. F. Ahlemann Information Systems and Strategic Management	Strategic planning of IS, Enterprise Architecture Management, IT Vendor Management, Project Portfolio Management, IT Governance, Strategic IT Benchmarking
Prof. Dr. P. Chamoni MIS and Management Science / Operations Research	Information Systems and Operations Research, Business Intelligence, Data Warehousing
Prof. Dr. K. Echtle Dependability of Computing Systems	Dependability of Computing Systems
Prof. Dr. S. Eicker Information Systems and Software Engineering	Process Models, Software-Architectures
Prof. Dr. U. Frank Information Systems and Enterprise Modelling	Enterprise Modelling, Enterprise Application Integration, IT Management, Knowledge Management
Prof. Dr. M. Goedicke Specification of Software Systems	Distributed Systems, Software Components, CSCW
Prof. Dr. V. Gruhn Software Engineering	Design of Software Processes, Software Architecture, Usability, Mobile Applications, Component-based and Generative Software Development
PD Dr. C. Klüver Computer Based Analysis of Social Complexity	Soft Computing, Modeling of Social, Cognitive, and Economic Processes, Development of Algorithms
Prof. Dr. T. Kollmann E-Business and E-Entrepreneurship	E-Business and Information Management, E-Entrepreneurship/E-Venture, Virtual Marketplaces and Mobile Commerce, Online-Marketing
Prof. Dr. K. Pohl Software Systems Engineering	Requirements Engineering, Software Quality Assurance, Software-Architectures, Evaluation of COTS/Open Source-Components
Prof. Dr. R. Unland Data Management Systems and Knowledge Representation	Data Management, Artificial Intelligence, Software Engineering, Internet Based Teaching
Prof. Dr. S. Zelewski Institute of Production and Industrial Information Management	Industrial Business Processes, Innovation Management, Information Management, Economic Analyses