

Manera, Matteo; Cologni, Alessandro

**Working Paper**

## The Asymmetric Effects of Oil Shocks on Output Growth: A Markov-Switching Analysis for the G-7 Countries

Nota di Lavoro, No. 29.2006

**Provided in Cooperation with:**

Fondazione Eni Enrico Mattei (FEEM)

*Suggested Citation:* Manera, Matteo; Cologni, Alessandro (2006) : The Asymmetric Effects of Oil Shocks on Output Growth: A Markov-Switching Analysis for the G-7 Countries, Nota di Lavoro, No. 29.2006, Fondazione Eni Enrico Mattei (FEEM), Milano

This Version is available at:

<https://hdl.handle.net/10419/73915>

**Standard-Nutzungsbedingungen:**

Die Dokumente auf EconStor dürfen zu eigenen wissenschaftlichen Zwecken und zum Privatgebrauch gespeichert und kopiert werden.

Sie dürfen die Dokumente nicht für öffentliche oder kommerzielle Zwecke vervielfältigen, öffentlich ausstellen, öffentlich zugänglich machen, vertreiben oder anderweitig nutzen.

Sofern die Verfasser die Dokumente unter Open-Content-Lizenzen (insbesondere CC-Lizenzen) zur Verfügung gestellt haben sollten, gelten abweichend von diesen Nutzungsbedingungen die in der dort genannten Lizenz gewährten Nutzungsrechte.

**Terms of use:**

*Documents in EconStor may be saved and copied for your personal and scholarly purposes.*

*You are not to copy documents for public or commercial purposes, to exhibit the documents publicly, to make them publicly available on the internet, or to distribute or otherwise use the documents in public.*

*If the documents have been made available under an Open Content Licence (especially Creative Commons Licences), you may exercise further usage rights as specified in the indicated licence.*

**The Asymmetric Effects of Oil  
Shocks on Output Growth:  
A Markov-Switching Analysis  
for the G-7 Countries**

Alessandro Cologni and Matteo Manera

NOTA DI LAVORO 29.2006

**FEBRUARY 2006**

IEM – International Energy Markets

Alessandro Cologni, *IMT Institute for Advanced Studies, Lucca, Italy*  
Matteo Manera, *Department of Statistics, University of Milan-Bicocca, Italy*  
and *Fondazione Eni Enrico Mattei*

This paper can be downloaded without charge at:

The Fondazione Eni Enrico Mattei Note di Lavoro Series Index:  
<http://www.feem.it/Feem/Pub/Publications/WPapers/default.htm>

Social Science Research Network Electronic Paper Collection:  
<http://ssrn.com/abstract=885506>

The opinions expressed in this paper do not necessarily reflect the position of  
Fondazione Eni Enrico Mattei  
Corso Magenta, 63, 20123 Milano (I), web site: [www.feem.it](http://www.feem.it), e-mail: [working.papers@feem.it](mailto:working.papers@feem.it)

# **The Asymmetric Effects of Oil Shocks on Output Growth: A Markov-Switching Analysis for the G-7 Countries**

## **Summary**

Oil shocks are generally acknowledged to have important effects on both economic activity and macroeconomic policy. The aim of this paper is to investigate how oil price shocks affect the growth rate of output of a subset of developed countries by comparing alternative regime switching models. Different Markov- Switching (MS) regime autoregressive models are, therefore, specified and estimated. In a successive step, univariate MS models are extended in order to verify if the inclusion of asymmetric oil shocks as an exogenous variable improves the ability of each specification to identify the different phases of the business cycle for each country under scrutiny. Following the wide literature on this topic, seven different definitions of oil shocks which are able to describe oil price changes, asymmetric transformations of oil price changes, oil price volatility, and oil supply conditions are considered. Our findings can be summarized as follows. While the introduction of different oil shock specifications is never rejected, positive oil price changes, net oil price increases and oil price volatility are the oil shock definitions which contribute to a better description of the impact of oil on output growth. In addition, models with exogenous oil variables generally outperform the corresponding univariate specifications which exclude oil from the analysis. However, a stability analysis of the coefficients across different subsamples shows that the role of oil shocks in explaining recessionary episodes has changed over time. Improvements in energy efficiency, together with a better systematic approach to external supply and demand shocks by monetary and fiscal authorities are argued to be responsible for the changing macroeconomic effects of oil shocks. Finally, the impact of G-7 countries aggregate growth on oil market conditions is considered and assessed empirically. The null hypothesis of the absence of a reverse relationship from real GDP growth to oil prices is rejected by the data.

**Keywords:** Oil shocks, Output growth, Markov-switching models

**JEL Classification:** E31, E32, E52, Q41

*The authors would like to thank Marzio Galeotti, Alessandro Lanza, Anil Markandya and Michael McAleer for insightful discussion, as well as seminar participants at the Fondazione Eni Enrico Mattei and at the University of Milan-Bicocca for helpful comments.*

*Address for correspondence:*

Matteo Manera  
Department of Statistics  
University of Milan-Bicocca  
Via Bicocca degli Arcimboldi, 8  
Building U7  
20126 Milan  
Italy  
Phone: +39 0264485819  
Fax: +39 026473312  
E-mail: [matteo.manera@unimib.it](mailto:matteo.manera@unimib.it)

# 1 Introduction

Oil shocks are generally acknowledged to have important effects on both economic activity and macroeconomic policy of developed countries. Huge and sudden increases in oil prices are assumed to precede economic slowdowns and increases of inflation rates. Oil shocks are not only indicative of the increased scarcity of an important factor of production, energy, but oil price increases can also be thought as a tax levied from oil exporting countries to oil consumers. Further, increases in the price level have the effect to reduce real money balances with negative effects on household wealth, and, consequently, on consumption and output.<sup>1</sup>

What is the impact of oil shocks on the business cycle of the G-7 countries from an empirical point of view? This paper aims at studying the dynamic relationship between the conditions on the oil market and the business cycle for the the world's most developed economies.<sup>2</sup> In order to investigate the ability of different Markov Switching models to capture business cycle asymmetries and to assess the role of oil price changes in affecting the mean level of output, this paper starts with analyzing the business cycle features in the real GDP series for each country. In particular, asymmetries are supposed to exist where the estimated parameters of the alternative MS specifications are indicative of different regime-dependent responses of real output. A general econometric framework which allows for regime switching in the dynamics of real GDP together with an empirical procedure aimed at comparing alternative MS models is therefore introduced. The persistence of each economic regimes, as well as the ability of each MS model to detect the business cycle dates as described by widely acknowledged statistical institutions (namely the Economic Cycle Research Institute, ECRI and the National Bureau of Economic Research, NBER) is, then, measured. Then, the advantages of the MS approach are compared with those of more general frameworks designed to detect distinct characteristics associated with different phases of the business cycle. The possibility to explore asymmetries through threshold autoregressive models (TAR) is, therefore, assessed.<sup>3</sup> Furthermore, other models that allow for a continuum of intermediate states (such as the Logistic and Exponential Smooth Threshold Autoregressive models, LSTAR and ESTAR - see, for instance, Granger and Teräsvirta, 1993, and Teräsvirta, 1994) are also examined.<sup>4</sup>

The second stage of our empirical analysis deals with the potential effects that different conditions in the oil market may have on the correct identification of alternative economic regimes and of the probabilities of switch-

---

<sup>1</sup> Additional explanations of the effects of oil price shocks are associated to adjustment costs, uncertainty, changes in the behavior of monetary authorities and effects on financial markets (for a detailed analysis of the channels of transmission of oil shocks, see Barsky and Kilian, 2004).

<sup>2</sup> Our research concentrates on the most developed economies. Since they have large buffer options (for instance, oil reserves as well as good policy instruments) they are likely to be less affected by oil shocks. For an analysis of the effects of oil shocks on less developed countries, see, for instance, Cunado and Perez de Gracia (2005). In their study, the effects of oil price shocks on economic activity and consumer price indexes are examined for a subset of six Asian Countries (Japan, Singapore, South Korea, Malaysia, Thailand and Philippines).

<sup>3</sup> In the SETAR specification, in particular, the underlying model determines endogenously the probabilities of switching between regimes: i.e. the history of the time series we can directly observe defines the nonlinearities of the model.

<sup>4</sup> For an updated survey of these models, see van Dijk et al. (2000).

ing from one to another. A novelty of this paper is that we explicitly assess the dynamic impact of exogenous oil shocks on the movements of real output by examining alternative specifications of MS models that differ in the parameters that switch across regimes (mean, intercept, autoregressive component). In this respect, our paper can be regarded as an extension of the studies by Raymond and Rich (1997), Clements and Krolzig (2002), and Holmes and Wang (2003).

An additional innovative feature of our study is that it provides a comparison of the ability of the most popular definitions of oil shocks to detect asymmetries in the oil-output relationship. Following the wide literature on this topic, seven different definitions of oil shocks are considered. In particular, oil shocks are proxied by oil price changes, asymmetric transformations of oil price changes (i.e. positive oil price changes and net oil price increases), oil price volatility (that is, scaled oil price increases and standard deviation of oil prices), and oil supply conditions.

Up to now we have considered whether oil shocks have negative effects on growth performance. However, one may argue that there is a reverse relationship which goes from developed countries' economic activity to oil prices. Might oil prices be affected by economic growth in the most developed countries?

A second objective of the paper is to assess whether recent price hikes had effects which are comparable with the impact of the past oil shocks. Are recent price hikes likely to have effects on real GDP which are comparable to the impact of the past oil shocks? An historical analysis of data seems to suggest that, thanks to likely better macroeconomic policies and to a lower oil energy intensity of their economies, the G-7 countries are less vulnerable to oil shocks with respect to the past.

The paper is structured as follows. Section 2 reviews the empirical literature on the macroeconomic effects of oil shocks. Section 3 presents the data. Section 4 describes the empirical framework to be used in the analysis. In Section 5 we present and discuss the empirical findings obtained by using regime switching specifications for the statistical assessment of the business cycle dynamics for the G-7 countries.<sup>5</sup> Particular emphasis to the role of oil in explaining business cycle features and to the presence of parameter stability in the econometric relationship is given in Sections 5.2 and 5.3. The issue of a simultaneous relationship between oil shocks and the economic activity is considered and assessed empirically in Section 5.4. Finally, in Section 6 we discuss the economic implications of our results: in particular, some explanations used to motivate why the statistical relationship between oil shocks and macroeconomic variables seems to have decreased over time are given. The importance of energy efficiency improvements and the role of macroeconomy policy (i.e., monetary and fiscal policy reactions) in explaining GDP changes is examined. Section 7 concludes.<sup>6</sup>

---

<sup>5</sup> All computations in this paper are carried out by using Eviews 6.0, Ox 3.4 (Krolzig's MS-VAR 1.32) and Rats 6.3 econometric packages.

<sup>6</sup> Additional graphs and tables that complete the analysis can be found in an Appendix which is available from the authors upon request.

## 2 Does oil matter? What the empirical literature says

Many studies are available which offer different theoretical explanations for the inverse relationship between oil price changes and the level of economic activity (see, inter alia, Brown and Yucel, 2002 and Brown et al., 2002). Many other contributions are directed to empirically test the existence of a statistical relationship between oil and the macroeconomy. The empirical literature devoted to assess the relationship between business cycle and oil price fluctuations has evolved, in particular, after 1973, the year of the first oil price shock (see Huntington, 2005 for an updated survey). The first two authors who estimate the impact of oil price increases on real income in the U.S. and other developed economies are Darby (1982) and Hamilton (1983). Darby, according to tests of significance of oil price variables on real income and simulation experiments, is not able to find a statistically significant relationship between oil price changes and real-income. However, if the indirect effects arising from variables such as exports, exchange rates and money supplies are taken into account, a significant impact of oil price changes can be detected. On the other hand, Hamilton, using post-war data, finds a statistically significant relationship between oil price changes and real GDP growth.<sup>7</sup>

Other studies confirm Hamilton's results. While Gisser and Goodwin (1986) introduce the growth rate of nominal crude oil price in St. Louis-type equations of four indicators of macroeconomic performance (namely, real GDP, general price level, rate of unemployment and real investment), Burbidge and Harrison (1984) use a vector autoregression (VAR) model and compute impulse responses to oil price changes. They find evidence of a causal relationship from oil price shocks to economic variables, although the results for some countries are ambiguous.

The failure of the 1986 oil price collapse to produce an economic boom has led several authors to hypothesize the existence of an asymmetric relationship between oil prices changes and economic activity. While oil price increases have clear negative effects, the impact of oil price declines is not always positive, indeed it may slow down output growth. Mork (1989) verifies that, if the Hamilton's analysis is extended to include the oil price collapse of 1986, the oil price-macroeconomy relationship breaks down.<sup>8</sup> Hence, he decides to test the symmetry hypothesis on U.S. data by allowing real increases and decreases in oil price to have different coefficients in a regression equation with real GDP as the dependent variable. The coefficients on oil price increases turn out to be negative and highly significant; the coefficients on price declines tend to be positive, but small and not statistically significant. In an extension of this analysis to other countries, Mork et al. (1994) find that all countries, except Norway, experience a negative relationship between oil price increases and GDP growth.

Other authors assert that the relationship between oil price shocks and U.S. macroeconomic fluctuations broke

---

<sup>7</sup> For an analysis directed to study the effects over time of unexpected changes in energy prices in the framework of a general non-linear model of dynamic factor demands, see Pindyck and Rotemberg (1983).

<sup>8</sup> Previously, the existence of asymmetric effects of oil price shocks on economic activity was explored by Tatom (1988).

down because of a new regime of highly volatile oil price movements. For example, Lee, Ni and Ratti (LNR) (1995) argue that an oil price shock is likely to have a greater impact in an economic environment where oil prices have been stable than in a context where oil price movements have been frequent and erratic.

A different specification for oil price changes has been proposed by Hamilton (1996). In direct response to Hooker (1996), who finds strong evidence that oil prices no longer do Granger-cause many U.S. macroeconomic variables after 1973, Hamilton introduces the concept of “net oil price increase” (NOPI), which is defined as the positive difference between the current oil price level and the maximum oil price relative to the previous four quarters. The introduction of NOPI in a VAR model for the U.S. economy is able to restore a significant relationship between oil prices and real GDP.

The hypothesis of direct effects of oil price shocks has been rejected by other studies. Actually, several economists have blamed the U.S. monetary policy to be responsible for the asymmetric response of aggregate economic activity following an oil price shock. For example, Bohi (1991) asserts that the restrictive monetary policy carried out by the central banks of the four countries considered in the study (Germany, Japan, U.K. and the U.S.) accounts for much of the decline in aggregate economic activity in the years which follow an oil price increase. In particular, he does not find any statistical relationship between energy-intensive industries and their level of energy-intensity, as well as no statistically significant effects of oil price shocks on the business cycle of four countries. This view is supported in a later study by Bernanke, Gertler and Watson (BGW) (1997). Using a VAR model, BGW conclude that, if the Federal Reserve had not increased interest rates after an oil price shock, the economic downturns that hit the U.S. might have been largely avoided. Finally, the analysis by Barsky and Kilian (2001) suggests that the Great Stagflation observed in the 1970s was primarily a monetary phenomenon: its effects could have been mitigated, should the Federal Reserve have not accommodated the massive monetary expansion of the early 1970s. The analyzes of Hamilton and Herrera (2004), Brown and Yucel (1999) and Balke, Brown and Yucel (2002) reject these conclusions. Their results are consistent with the thesis that counter-inflationary monetary policy is only partially responsible for the real effects of oil price shocks that hit the U.S. during the last thirty years.

The analysis of the macroeconomic impacts of oil shocks has been extended to countries other than U.S. only recently. Cunado and Perez de Gracia (2003) concentrate on the effects of oil price shocks on the industrial production and consumer price indices for 14 European countries. Jimenez-Rodriguez and Sanchez (2005) and Cologni and Manera (2006) carry out multivariate regressions for the most developed countries in order to account, respectively, for the inverse relationship between GDP and oil prices and the reaction of monetary variables to external shocks. Kilian (2006) estimates the effects of exogenous shocks to global oil production on the most industrialized countries. Other authors have proposed the use of more advanced econometric techniques. In particular, Raymond and Rich (1997), Clements and Krolzig (2002) and Holmes and Wang

(2003) use the MS approach to assess the impact of oil shocks on U.S. and U.K. business cycles. Huang et al. (2005) apply a multivariate threshold model to investigate the impacts of oil price changes and their volatility on economic activity.<sup>9</sup>

### 3 The data

In this study we employ quarterly data for the period 1970q1-2005q1.<sup>10</sup> For each country the real price of oil (*roil*) is obtained by multiplying the nominal oil price (average crude oil price) expressed in U.S. dollars by the nominal exchange rate and deflating it by using the Consumer Price Index (CPI).<sup>11,12</sup> The natural logarithm of real GDP in first differences is referred to as the output growth rate,  $\Delta gdp_t$ . The macroeconomic data we use are from the International Financial Statistics databases (IFS). For Italy, the source of real GDP is ISTAT. For France, while the data since 1978q1 are from INSEE, observations referring to the period 1970q1-1977q4 are obtained by considering the growth rates based on IFS data (nominal values deflated by the GDP deflator). For U.K. the IFS data have been seasonally adjusted.

In order to account for the asymmetric effects of an oil shock, we introduce seven different definitions of oil shocks. The first is simply the real price of oil in first differences, i.e.  $\Delta roil_t$ ,  $t = 1, \dots, T$ . The second variable is defined as the positive change in the natural logarithm of the real oil price (see Mork, 1989):

$$\Delta roil_t^+ = \begin{cases} \Delta roil_t & \text{if } \Delta roil_t > 0 \\ 0 & \text{if } \Delta roil_t \leq 0 \end{cases}$$

The third specification of oil shocks is based on the movements of oil prices in the last year. More precisely, net oil price increases (NOPI) are defined as the difference between the current real price of oil and the previous year's maximum if positive, or zero otherwise:

$$NOPI_t = \begin{cases} roil_t - \max \{roil_{t-1}, \dots, roil_{t-4}\} & \text{if } roil_t > \max \{roil_{t-1}, \dots, roil_{t-4}\} \\ 0 & \text{otherwise} \end{cases}$$

Following the work by LNR (1995), the fourth oil shock variable we consider is aimed at capturing the volatility in the oil price market. In particular, LNR normalize the oil price changes with their GARCH volatility, estimated according to the following model:

$$roil_t = \alpha_0 + \alpha_1 roil_{t-1} + \alpha_2 roil_{t-2} + \alpha_3 roil_{t-3} + \alpha_4 roil_{t-4} + \epsilon_t, \quad \epsilon_t | I_{t-1} \sim N(0, h_t)$$

<sup>9</sup> Recent works on the relationship between oil shocks and macroeconomy are those by Blanchard and Gali (2007) and Nordhaus (2007).

<sup>10</sup> For Japan the sample goes from 1970q1 to 2004q3, while for Canada and U.S. the period spanned is 1970q1-2004q4.

<sup>11</sup> Since 1999q1 the exchange rate of Italy, Germany and France is computed by considering the irreversible parity rate with Euro.

<sup>12</sup> The CPI index is used in order to deflate the oil price according to Ferderer (1996) and Cunado and de Gracia (2003) *inter alia*.



$$h_t = \gamma_0 + \gamma_1 \epsilon_{t-1}^2 + \gamma_1 \epsilon_{t-1}^2$$

$$\text{LNR}_t = \max(0, \hat{\epsilon}_t / \sqrt{\hat{h}_t})$$

The fifth definition of oil price shocks draws from Ferderer (1996), who introduces the quarterly standard deviation of oil prices:

$$\text{oil\_vol}_q = \left[ \frac{1}{4} \sum_{m=1}^4 (\text{oil}_{q,m}) / (\text{cpi}_{q,m}) - \mu_{q,m}^2 \right]^{1/2}$$

where  $\text{oil}_{q,m}$  and  $\text{cpi}_{q,m}$  are the nominal price of oil (in national currency) and the Consumer Price Index in the  $m$ -th month of the  $q$ -th quarter, respectively.

In order to disentangle the impact of large oil shocks from that of smaller ones a different non-linear specification for oil price shocks is introduced (see Gronwald, 2006). This new oil price specification considers only large oil price movements as determined by estimating a  $MSH(3) - AR(p)$  model<sup>13</sup> for national oil price first differences. More formally, it is equal to the linear real oil price first differences when, according to the estimated filtered probability, the regime of large oil price hikes ( $Pr(s_t = 3 | \text{oil}_t)$ ) is most likely to be observed, i.e. this variable is defined as follows:

$$\text{oil\_regime}_t = \begin{cases} \text{oil}_t & \text{if } Pr(s_t = 3 | \text{oil}_t) \geq 0.5 \text{ and } \text{oil}_t > 0 \\ 0 & \text{otherwise} \end{cases}$$

Finally, the seventh specification defines as oil shocks the exogenous fluctuations in the production of oil,  $\text{oil\_disr}$  (see Kilian, 2005 and 2006). This variable is based on monthly production data for OPEC and non-OPEC countries.<sup>14</sup>

## 4 The econometric framework

### 4.1 The Markov-Switching approach

Starting with the work of Hamilton (1989), the Markov-Switching (MS) autoregressive time series models have emerged as an interesting alternative to describe specific features of the business cycle.<sup>15</sup> Consequently, a growing number of empirical works have employed regime-switching models in order to capture nonlinearities and asymmetries which are present in many macroeconomic variables (see, among the others, Artis et al., 2004,

<sup>13</sup> MS model which assumes regime-switches in the heteroskedasticity of residuals. For an econometric definition of this model see Section 4.1. See also footnote 20.

<sup>14</sup> The variable  $\text{oil\_disr}$  is based on the dynamics of oil production in absence of any exogenous disruption of oil supply. For an alternative formulation see Hamilton (2003). Given the availability of data on oil supply from the Energy Information Agency, this variable can be computed only for the period 1974q1-2004q4.

<sup>15</sup> Recently, this econometric framework has been used in order to model other economic variables, for instance exchange rates (e.g. Engel, 1994, Engel and Hamilton, 1990 and Jeanne and Masson, 2000), interest rates (Ang and Bekaert, 1998, Dahlquist and Gray, 2000 and Hamilton, 1988, *inter alia*) stock returns (see, among other, Abel, 1992 and Cecchetti et al., 1990).

Boldin, 1996, Filardo, 1994, Goodwin, 1993, Krolzig, 1996, 1997, Krolzig et al., 2002, Krolzig and Toro, 2000 and Clements and Krolzig, 2001, 2002).

In his basic specification, the Markov Switching model assumes that deviations of output growth from its mean follow a  $p$ -th order autoregressive process:

$$\Delta gdp_t - \mu(s_t) = \alpha_1(\Delta gdp_{t-1} - \mu(s_{t-1})) + \dots + \alpha_p(\Delta gdp_{t-p} - \mu(s_{t-p})) + \epsilon_t \quad (1)$$

The errors  $\epsilon_t$  are assumed to be independently and identically distributed (IID) with zero mean and constant variance  $\sigma^2$ , while the mean of the process ( $\mu$ ) depends on a latent variable  $s_t$ . Since this dependence implies that different regimes are associated with different conditional distributions of the growth rate of real output, the latent variable  $s_t$  reflects the state of the business cycle (in case of two regimes, “expansion” and “contraction”). The autoregressive parameters of model (1) can be functions of the state  $s_t$  in the Markov chain:

$$\Delta gdp_t = c(s_t) + \alpha_1(s_t)\Delta gdp_{t-1} + \dots + \alpha_p(s_t)\Delta gdp_{t-p} + \epsilon_t \quad (2)$$

If  $s_t$  takes one of the  $M$  different values represented by the integers  $1, 2, \dots, M$ , equation (2) represents a mixture of  $M$  autoregressive models. In a two-regime case, model (2) describes “falling” states (for example, if  $s_t = 1$ ) as well as “rising” states (when  $s_t = 2$ ) in the output variable. In particular, an economy in recession can be represented as:

$$\Delta gdp_t = c_1 + \alpha_{11}\Delta gdp_{t-1} + \dots + \alpha_{p1}\Delta gdp_{t-p} + \epsilon_t$$

while, if the economy is in expansion, the growth rate of output will be modelled by the alternative equation:

$$\Delta gdp_t = c_2 + \alpha_{12}\Delta gdp_{t-1} + \dots + \alpha_{p2}\Delta gdp_{t-p} + \epsilon_t$$

It is worth noting that the parameters of the conditional process depend on a regime which is assumed to be stochastic and unobservable. Therefore, a complete description of the data generating process (DGP) requires the formulation of the regime generating process. In MS models the latter process is an ergodic Markov chain with a finite number of states, which is defined by the transition probabilities:

$$p_{ij} = Pr(s_t = j | s_{t-1} = i), \quad \sum_{j=1}^M p_{ij} = 1$$

for  $\forall i, j = 1, \dots, M$ . More precisely, it is assumed that  $s_t$  follows an ergodic  $M$ -state Markov process with an irreducible transition matrix:

$$P = \begin{bmatrix} p_{11} & p_{12} & \dots & p_{1M} \\ p_{21} & p_{22} & \dots & p_{2M} \\ \dots & \dots & \ddots & \dots \\ p_{M1} & p_{M2} & \dots & p_{MM} \end{bmatrix}$$

where  $p_{i1} + p_{i2} + \dots + p_{iM} = 1$  for  $i = 1, \dots, M$ . In a two-regime case (i.e.  $M = 2$ ), this specification assumes that, if the economy was in expansion last period, the probability of a regime switching is constant and independent of the persistence of the expansion.

## 4.2 A model selection strategy

The empirical procedure aimed at comparing alternative MS models can be described as follows. The starting point is to test for the presence of nonlinearities in the data. In our analysis we employ the test developed by Ang and Bekaert (1998), which, under the null hypothesis that there are no regime shifts, is approximately distributed as a  $\chi^2(q)$ , where  $q$  represents the number of restrictions and nuisance parameters that are not defined under the null hypothesis.<sup>16</sup>

The second relevant issue is how to determine the number of states required by each model to be an adequate characterization of the observed data. Unfortunately, simple and direct statistical criteria cannot be used. Our empirical procedure follows Psaradakis and Spagnolo (2003), who suggest to select the number of regimes using the Akaike Information Criterion (AIC). Monte Carlo experiments show that selection procedures based on the AIC (and on the so-called “three-pattern method”) are generally successful in determining the correct number of regimes, “provided that the sample size and parameter changes are not too small”.<sup>17</sup>

The third important aspect we consider in our selection strategy is the number of autoregressive terms to include in the process. We use both AIC and LR tests in order to discriminate between a  $p$ -lag and a  $q$ -lag MS process. Once the optimal specification within a particular type of MS models is obtained, the final stage of our selection procedure is to compare the different types of selected models, which are generally non-nested. Our comparison is based on the following criteria: i) model fit, as summarized by the standard error of the residuals; ii) value of the log-likelihood function; iii) values of means and/or intercepts estimated in the different economic regimes; iv) relation between the probability of regime switching and the macroeconomic fundamentals. This last criterion is of particular importance. It is generally acknowledged that the probability of a low growth state should be smaller than the probability of high growth, since recessions are recognized to be more short-lived than expansions. From the estimated transition probabilities we measure the persistence of the different economic

<sup>16</sup> In particular, it tests whether parameters are equal across regimes. For instance, in the case of the MSM(2)-AR(p) model (see equation 1) the null hypothesis of the likelihood ratio (LR) test is:  $\mu_1 = \mu_2$ .

<sup>17</sup> Boldin, (1996) proposes to use a likelihood ratio (LR) test to determine the state dimension of a series. The implementation of such a test is, nevertheless, problematic. Actually, since the usual regularity conditions are not fulfilled under the null hypothesis (some parameters are unidentified and the information matrix is singular), the asymptotic null distribution of the LR test is not  $\chi^2$ . In order to circumvent these problems alternative statistics have been introduced (see, among others, Hansen, 1992 and 1996), which, unfortunately, are computationally expensive. In practice, the state dimension of the hidden Markov chain that drives regime changes is either suggested by the specific problem under analysis, or determined informally by a simple visual inspection of the data.

phases. By assigning the  $t$ -th observation of the GDP to the  $m$ -th regime with the highest smoothed probability, we produce a model-based classification of regimes and dates of the business cycle phases for each country (see Hamilton, 1995).<sup>18</sup> Finally, our empirical findings are compared with the business cycle dates provided by official institutions, such as the ECRI and NBER, as reported in Table 1.

[INSERT TABLE 1 ABOUT HERE]

## 4.3 Effects of oil shocks

### 4.3.1 Model specification

In this section, the analysis is extended to test whether oil prices affect the mean of the real GDP growth process. The dynamic linkages between oil and real GDP are explored by adding lagged coefficients of the oil market variable to the autoregressive MS model for  $\Delta gdp_t$ .<sup>19, 20</sup>

The first specification we estimate is an extension of equation (1), known as the MS-mean (MSM) model according to the notation introduced by Krolzig (1997):

$$\Delta gdp_t - \mu(s_t) = \sum_{i=1}^p \alpha_i (\Delta gdp_{t-i} - \mu(s_{t-i})) + \sum_{j=1}^q \gamma_j oil_{t-j} + \epsilon_t \quad (3)$$

$$\epsilon_t \sim IID(0, \sigma^2) \quad (4)$$

where  $oil_t$  represents one of the seven alternative specifications of oil price shocks described in Section 3 (namely,  $\Delta roil$ ,  $\Delta o^+$ , NOPI, LNR,  $oil\_vol$ ,  $oil\_regime$  and  $oil\_disr$ ). Moreover,  $s_t$  is a latent variable which reflects the state of the business cycle. When  $s_t = m$ ,  $m = 1, \dots, M$ , the real GDP average growth rate is given by the parameter  $c(m) \equiv c_m$ . The number of lags  $q$  for the oil price variable is equal to four, following Clements and Krolzig (2002). If the MSM model (3)-(4) accounts for a once-and-for-all jump in the real GDP series, the MS-intercept (MSI) model:

$$\Delta gdp_t = c(s_t) + \sum_{i=1}^p \alpha_i \Delta gdp_{t-i} + \sum_{j=1}^q \gamma_j oil_{t-j} + \epsilon_t \quad (5)$$

<sup>18</sup> For the simplest case of two regimes, our selection rule reduces to assign the  $t$ -th observation of the GDP to the first regime if  $Pr(s_t = 1 | gdp_t > 0.5)$ , or to the second regime if  $Pr(s_t = 1 | gdp_t < 0.5)$ .

<sup>19</sup> This econometric framework implicitly allows us to verify if the principal channel of effect of oil shocks is on the mean of output process, as argued by Raymond and Rich (1997) and by Clements and Krolzig (2002), or in the autoregressive structure of the variable, see next part.

<sup>20</sup> When MS models for oil only are estimated, the selection criteria illustrated in Section 4.2 indicates the autoregressive specification with switching error variance on three regimes as the preferred model. Our empirical findings suggest that the oil price series switches from low to high volatility. However, although oil prices seem to be characterized by a nonlinear pattern, for each country the regimes characterizing real GDP do not coincide with those representing the oil market. Therefore, the framework adopted by Hamilton and Lin (1996), where a single latent variable (i.e. the state of the economy) determines both the mean of real GDP growth and the scale of the volatility of the exogenous variable, can not be implemented.

implies a shift in the intercept  $d(s_t)$ , that is a smooth adjustment of the DGP after a regime shift. It is important to notice that MSI specification assumes the same variance (4). Models (3)-(4) and (5)-(4) can be easily generalized in two directions. Since output volatility in recessions is generally different from the volatility which characterizes economic expansions, extensions of the univariate models can incorporate a regime-varying variance of the disturbance terms:

$$\epsilon_t \sim IID(0, \sigma^2(s_t)) \quad (6)$$

Equations (3)-(6) define the MSM-heteroskedastic (MSMH) models, whereas the MSI-heteroskedastic (MSIH) specification combines model (5) with (6). The second direction deals with the parameters of the autoregressive part of the MSI models, which become functions of the state variable  $s_t$ . Formally, the MSI-autoregressive (MSIA) model is written as:

$$\Delta gdp_t = c(s_t) + \sum_{i=1}^p \alpha_i(s_t) \Delta gdp_{t-i} + \sum_{j=1}^q \gamma_j(s_t) oil_{t-j} + \epsilon_t, \quad \epsilon_t \sim IID(0, \sigma^2) \quad (7)$$

and it assumes the homoskedastic error structure (4), while the MSI-autoregressive-heteroskedastic (MSIAH) specification is obtained by combining equations (7) and (6).

#### 4.3.2 Econometric stability of the oil-macroeconomy relationship

In order to test whether recent price hikes had effects on real GDP which are comparable with the impact of the shocks that happened during the 1970s, two sorts of recursive estimates of all regressions are computed. In a first experiment, recursive regressions are obtained by fixing the starting observation at the first quarter of 1970. Step-by-step, the size of the subsamples is increased (from 1989q4 to the ending observation of the full sample) (“fixed starting observation, variable ending observation”). In a second exercise, we consider samples (of quarterly data) which begin from 1970q1 to 1989q4 and end in 2005q1 (“variable starting observation, fixed ending observation”). Significance of the oil variable is assessed by means of LR tests.

Finally, in order to verify whether these patterns can be described as a structural break in the oil-macroeconomy relationship, three different tests are carried out. Let us partition the data into two subsamples:  $\Delta gdp = [\Delta gdp_1, \Delta gdp_2]'$  and  $X = [X_1, X_2]$  where  $X = [\Delta gdp_{t-i}, oil_{t-j}]'$  ( $i = 1, \dots, p$  and  $j = 1, \dots, q$ ) is the set of explanatory variables. In order to test whether only intercepts differ across subsamples, the following models are estimated:

- *unrestricted model*

$$\begin{bmatrix} \Delta gdp_1 \\ \Delta gdp_2 \end{bmatrix} = \begin{bmatrix} i_1 & 0 \\ 0 & i_2 \end{bmatrix} \begin{bmatrix} c(s_t)_1 \\ c(s_t)_2 \end{bmatrix} + \begin{bmatrix} X_1 \\ X_2 \end{bmatrix} \beta(s_t) + \epsilon_t \quad (8)$$

- *restricted model*

$$\begin{bmatrix} \Delta gdp_1 \\ \Delta gdp_2 \end{bmatrix} = \begin{bmatrix} i_1 \\ i_2 \end{bmatrix} c(s_t) + \begin{bmatrix} X_1 \\ X_2 \end{bmatrix} \beta(s_t) + \epsilon_t \quad (9)$$

where  $i_1$  and  $i_2$  are vectors of ones. The null hypothesis  $H_0 : c(s_t)_1 = c(s_t)_2$  is then tested by considering a log-LR test ( $LR_1 = 2 \cdot (\log L(\hat{c}(s_t), \hat{\beta}(s_t))_{unrestr} - \log L(\hat{c}(s_t), \hat{\beta}(s_t))_{restr})$ ) which is distributed according to a  $\chi^2$  with  $d$  degrees of freedom (where  $d$  is the number of restrictions assumed in the model).

In order to test whether slope coefficients differ across subsamples a second LR test is carried out. In particular, the unrestricted and restricted models are respectively given by:

$$\begin{bmatrix} \Delta gdp_1 \\ \Delta gdp_2 \end{bmatrix} = \begin{bmatrix} i_1 & 0 \\ 0 & i_2 \end{bmatrix} \begin{bmatrix} c(s_t)_1 \\ c(s_t)_2 \end{bmatrix} + \begin{bmatrix} X_1 & 0 \\ 0 & X_2 \end{bmatrix} \begin{bmatrix} \beta_1(s_t) \\ \beta_2(s_t) \end{bmatrix} + \epsilon_t \quad (10)$$

and equation (8). In this case the null hypothesis to test is:  $H_0 : \beta_1 = \beta_2$ .

A third LR test is carried out by assuming a structural break both in the intercepts and slopes. In this case the unrestricted and restricted models are respectively given by equations (10) and (9). The null hypothesis is the following:  $H_0 : c(s_t)_1 = c(s_t)_2$  and  $\beta_1 = \beta_2$ .

To notice that, since the structural break is assumed to be unknown, data are partitioned by considering all possible subsamples. Structural break is assumed when the  $p$ -value of the LR tests has the lowest values.<sup>21</sup>

### 4.3.3 Simultaneity issue

Exogenous political events (such as the outbreak of wars, embargoes, instability of institutions etc.) together with decisions by OPEC, the major actor of the market, are argued to have induced important changes in oil prices (see Barsky and Kilian, 2004 and Mabro, 1998, for instance). World macroeconomic conditions may, however, have effects on oil price behaviour through the link between economic growth and energy consumption (and, hence, via their demand on oil related products, see Kaufmann, 1995). Oil prices may also be affected because of the great political influence the developed countries are argued to have over the major oil exporters. Our aim is to test whether faster economic growth leads to a corresponding increase in prices. Indirectly, we are interested in assessing how oil shocks affect macroeconomic activity if this reverse relationship is also accounted for.

In order to test whether these countries have been able to affect oil market conditions (oil supplies and oil prices) an aggregate measure of log real GDP for the G-7 countries ( $gdpG7_t$ ) is calculated following a scheme similar to that adopted by Marcellino et al. (2003). For each quarter, we employ a measure computed

<sup>21</sup> In order to test structural breaks in the mean growth rates of real GDP and in the variance of the error term, Kim and Nelson (1999) suggest a bayesian methodology based on a MS model. Replication of this technique is behind the scope of the paper. Furthermore, we argue that our approach, though very simple and intuitive, seems to ‘fit’ the purpose of verifying whether coefficients associated to oil variable change over time.

by weighting the real GDP growth rates for the seven countries. The weights are given by the relative share of each country’s nominal GDP, measured in current U.S. dollars. A bivariate MS-VAR model for the first difference of  $gdpG7_t$  and the oil shock specifications described in Section 3 is, then, estimated. For instance, in the case of the MSM-VAR( $p$ ), where  $p$  is the order of the autoregression, the equation to estimate is given by:<sup>22</sup>

$$y_t - \mu(s_t) = \Gamma_1 (y_{t-1} - \mu(s_{t-1})) + \dots + \Gamma_p (y_{t-p} - \mu(s_{t-p})) + \epsilon_t$$

where  $\epsilon_t$  is assumed  $IID(0, \sigma^2)$ <sup>23</sup> while the vector  $y_t$  includes the log real GDP in first differences ( $\Delta gdpG7_t$ ) and the oil shock specification ( $oil_t$ ). To the extent that the economic growth rate of the U.S. (world’s largest economy) is able to have effects on oil price movements, the same estimation scheme is replied by using the U.S. real GDP growth series.

## 5 Empirical results and discussion

### 5.1 Univariate MS models

The analysis starts by examining for each country the statistical properties of the two-regime MS models for quarterly real GDP growth.<sup>24</sup> Our empirical evidence suggests that an appropriate formulation of this model can be used to adequately describe the business cycle of Canada and France.<sup>25</sup> In particular, for Canada, if a MSM model is estimated over the period 1970-2004, we obtain that all coefficients are statistically significant at conventional significance levels. Furthermore, the coefficients associated with the two means of the process point out that in regime 1 the economy experiences a negative growth. According to the estimated transition probabilities, regime 1 is able to detect the economic slowdowns of 1973, 1981-1983 and 1990-1991, whereas in regime 2 real GDP actually increases by about one percentage point. Low growth rate phases tend to last, on average, three quarters, in contrast with the five-year length of high growth periods.

On the contrary, for France, if we consider a two-regime univariate model for real GDP growth, we can observe that the empirical results produced by the MSI model are quite satisfactory. Both constants are statistically significant; furthermore while slow growth economic phases (namely, 1974-1975, 1977-1987, 1990-1997 and 2001-2004) are attributable to regime 1, regime 2 describes a larger portion of the observed data. If high growth phases tend to last on average 8.56 quarters, sluggish economic growth periods are more persistent (i.e. 19

<sup>22</sup> All MS specifications described in Section 4.3.1 are employed.

<sup>23</sup> We are not assuming heteroskedasticity in the error process.

<sup>24</sup> For further details on the results of univariate models for GDP growth see the working paper version of this paper.

<sup>25</sup> On the other hand, for instance, if we estimate a MSM(2)-AR(4) model for Germany, we obtain that only the mean for regime 2 (which denotes switches from low-growth to high-growth periods) is statistically significant.

quarters).<sup>26</sup>

The next step is to estimate MS models with three regimes. As far as Canada is concerned, a MSM(3)-AR(4) specification, that is a MSM with three regimes with a four-lag autoregressive component, presents the best econometric performance.<sup>27</sup> All coefficients are statistically significant, and, compared with the peaks and troughs of the Canadian business cycle reported in Table 1, the three regimes have a neat economic interpretation. In particular, the first regime is able to detect the periods of recessions which have characterized the last thirty years of the Canadian economy (namely, 1973, 1981-1983 and 1990-1991), while regime 3 well describes the periods of high economic growth. Similar results are obtained by considering an MSI-type model. In this case, six lags on the GDP are used in order to capture the dynamic structure of the dependent variable.<sup>28</sup>

Similarly, for France, if we extend the analysis to three regimes, a MSMH(3)-AR(4) model where a dummy variable is employed to remove an outlier in correspondence of the fourth quarter of 1974, presents good economic properties.<sup>29</sup> The three mean-coefficients are statistically significant and describe low, moderate and high growth periods, respectively. According to this model, periods 1977-1987, 1990-1997 and 2001-2004 are characterized by low economic growth. In regimes 1 and 3 standard error are larger, suggesting higher volatility. If we allow the autoregressive component of real GDP to vary across regimes, switches from one economic regime to another can be described more accurately. It is worth noticing that, according to the AIC, six lags are needed to capture the dynamic structure of the series. The estimates of the three intercept terms are slightly different, with the third regime the most persistent.

For Germany, more robust statistical results are obtained if the model is extended to allow the series to switch among three different economic regimes, as well as assuming regime-dependent intercepts, autoregressive components and heteroskedastic errors (i.e. the MSIAH(3) specification).<sup>30</sup> The three regimes can be attributed to different economic phases, namely null, moderate and high economic growth, with the first regime characterizing the periods 1973-1975, 1980-1983 and 1991-2004. According to this model, regime 1 tends to last 22 quarters on average, while regime 2 is less persistent (4.30 quarters). Finally, high growth periods tend to last 10 quarters on average.

---

<sup>26</sup> If a MSIH model is estimated, empirical findings strongly reject the null hypothesis that recessions are more volatile than expansions. Finally, for this model regime switches have no sound economic meaning. An alternative specification is obtained by removing the restrictions on the autoregressive part of the model. For the MSIA specification regime switches have an implausible economic interpretation, in fact only one observation can be attributed to regime 1. This limitation persists also if we consider a MSIAH model.

<sup>27</sup> As in the two-regime analysis, the LR test for linearity generally strongly suggests that real GDP is characterized by a nonlinear behavior. However, see Hamilton (1996) for a critical discussion of this test.

<sup>28</sup> If we allow the error variance to vary across regimes, we do not obtain a significant improvement in the likelihood function. Similar results are found by relaxing the restrictions on the autoregressive component of this model.

<sup>29</sup> By contrast, a MSM(3)-AR(3) model for real GDP is not able to describe the French business cycle. While regimes 1 captures only the serious recession of 1974, regime 2 and 3 represent, respectively, zero-growth periods and high growth periods.

<sup>30</sup> All specifications for Germany use a dummy variable for the first quarter of 1991, which takes into account a structural break in the series due to the reunification of West and East Germany.



Our empirical findings point out that, in general, three-regime models tend to outperform the corresponding models with two regimes even for Italy,<sup>31</sup> Japan, U.K. and the U.S. For Italy, the MSM(3)-AR(3) specification, for instance, merits some attention. The first mean coefficient suggests that in regime 1 GDP tends to grow at a 0.13% rate. Regime 2 covers moderate growth rate periods, while state 3 can be related to the post-recession periods of rapid growth. More specifically, in the high-growth regime, real GDP growth rate is equal to 1.28%. The coefficients associated with the three-lag autoregressive structure of this model are statistically significant at 5%.

For Japan, we obtain the most interesting findings with a MSMH model, where the error variance is allowed to vary across regimes, together with the means of the GDP process. For this specification, regime 1 represents mild recessionary periods, while regime 2 and 3 denote moderate and high growth states. Two lags are sufficient to capture the dynamics of the GDP series. High growth periods are characterized by the largest volatility. On the contrary, moderate growth tends to be less volatile. The average durations of the three regimes are 3.83, 7.09 and 7.45 quarters, respectively. The model describes quite well the business-cycle peaks and troughs as indicated by ECRI, and it captures almost all the turning points.

Even in the case of U.K., MSM specifications are empirically superior to other counterparts. In particular, the three coefficients which capture the average of GDP in the MSM(3)-AR(4) model are statistically significant. Regime 1 describes recessionary phases, regime 2 denotes periods of moderate growth, whereas regime 3 represents high growth economic performances. As far as the dynamics of the series is concerned, all four lags on GDP are statistically significant, all with a negative sign. Business cycle peaks and troughs are well captured by the model. A moderate growth phase lasts on average 38 quarters and tends to be followed by a high growth regime. On the other hand, the computed probability (i.e.  $Prob(s_t = 3 | s_{t-1} = 1) = 0.25$ ) reflects the high chance that a recession is followed by a period of high growth. Since, as suggested by the value of AIC, the null hypothesis of no heteroskedastic errors is rejected by the data, we have extended the MSM model to a MSMH(3)-AR(3) specification, which appears to adequately represent the main features of the business cycle. Finally, our empirical evidence suggests that different models can be used to adequately describe the U.S. business cycle. A MSM(3)-AR(4) specification describes the three regimes as recession, moderate growth and high growth. If we relax the assumption of constant error variance, we obtain a generalized improvement of the statistical properties of the resulting MS models. However, specifications MSMH or MSIH are not able to detect the recessions which characterize the last thirty years of the U.S. economic history. In particular, time periods such as 1990q3-1991q1 and 2001q1-2001q4 are not correctly identified as recessionary episodes.

To summarize, given the success of the seminal article by Hamilton (1989), two-regime MS models are the most

---

<sup>31</sup> In this context our results represent an extension of the previous work of Stanca (1999) which, by using 2 regimes MS model, was able to describe expansions and contractions as regimes of positive high and low, but positive, growth.

widely used in the empirical literature. However, our estimates confirm that more robust results come from models which incorporate three regimes.<sup>32</sup> The specifications which seem to be the most adequate to represent the business cycle of the seven countries are the benchmark MSM and MSMH representations. A noticeable exception is represented by Germany for which a MSIAH model outperforms univariate alternatives.

### 5.1.1 Empirical performances of other univariate models

This paper deals with the analysis of MS models. Therefore, one feature of such methodology is that it results in models which are characterized by “sudden” regime changes. Since, in economic analysis of the business cycle other approaches which imply non-linearities are used, a question that immediately arises is the following: are models with smooth regime switching behavior preferable? In this section, the properties of MS models are compared with the business-cycle features generated by alternative non-linear models.<sup>33</sup> In particular, (1) simple AutoRegressive (AR),<sup>34</sup> (2) Self-Exciting Threshold AutoRegressive (SETAR) and (3) Exponential Smooth Transition AutoRegressive (ESTAR) models are examined. Our aim is to verify whether the observed business cycle features of real GDP are likely to have been generated by these alternative DGP and compare the results with the outcome of MS models.<sup>35</sup>

According to threshold autoregressive models, the DGP of the variable  $\Delta gdp_t$  can be specified as:<sup>36</sup>

$$\Delta gdp_t = [\alpha_0 + \beta_0 F(Z_t)] + \sum_{i=1}^p [\alpha_i + \beta_i F(Z_t)] \Delta gdp_{t-i} + \epsilon_t \quad (11)$$

where  $\epsilon_t$  is  $IID(0, \sigma^2)$  and  $\alpha_j$  and  $\beta_j$  with  $j = 0, 1, \dots, p$  are the parameters of interest. According to these parameters and to the specification of the function  $Z_t$  the AR (AutoRegression), TAR (SETAR), STAR (ESTAR and LSTAR specifications) models can be obtained as special cases.<sup>37</sup> In particular, if we assume  $F(Z_t) = I[q_{t-1} > \gamma]$  (where  $I$  denotes the indicator function and a known function of the data is defined by  $q_{t-1} = q(\Delta gdp_{t-1}, \dots, \Delta gdp_{t-p})$ ) the two regime Threshold AutoRegressive (TAR) model can be specified. In

<sup>32</sup> Results which accord well with the analyses of Sichel (1994) and Boldin (1996).

<sup>33</sup> Results on the set of estimated univariate models are reported in the Appendix.

<sup>34</sup> As far as the estimation procedure of the simple AR model, the number of lags ( $p$ ) is selected according to the value of the AIC. The coefficients on the autoregressive terms which are not significantly different from zero at the 5% level are restricted to zero. The model is then re-estimated accordingly. This restriction is tested for consistency by considering a Wald test. The possibility to reject the null hypothesis of serial autocorrelated residuals is finally verified.

<sup>35</sup> To notice that we do not consider the forecasting performances of non-linear models. In fact, they do not allow us to validly compare the different models considered. As Montgomery et al (1998) argue, in an analysis of the performances of rolling forecasts “[...] the MSE [Mean Squared Errors] may not be the appropriate criterion for evaluating the performance of the model”. MS models tend to have poor forecasting performances since the classification of the economic regime is characterized by a certain degree of uncertainty.

<sup>36</sup> As argued by Potter (1995), these models can be seen as “special cases of non-linear models with a single index restriction”. In particular, equation (11) is defined as a univariate Single Index Generalized Multivariate Autoregressive (SIGMA) model.

<sup>37</sup> Notice that, even the regime-switching model of Hamilton (MSM(2)-AR(4)) can be obtained from the specified framework by assuming  $F(Z_t) = K_t$  where  $K_t$  is a two-state Markov chain. On the contrary, if  $\alpha_0 = \beta_j = 0$  ( $j = 0, \dots, p$ ) a simple  $AR(p)$  model is defined.

particular if we assume that  $F(Z_t) = I[\Delta gdp_{t-d} > \gamma]$  a SETAR ( $d, \gamma$ ) (Self Exciting Threshold AutoRegressive) model is defined. The two parameters  $d$  (with  $d \in [1, \bar{d}]$ ) and  $\gamma$  represent, respectively, the delay lag and the threshold parameter that have to be estimated. On the other hand, if  $F(Z_t)$  is a transition function between the two regimes designed such that  $0 \leq F \leq 1$  with  $F = 0$  and  $F = 1$  signalling regimes 1 and 2 respectively, the two-regime STAR (Smooth Transition AutoRegressive) model (or single transition function STAR model) of order  $p$  is defined. According to the two specifications generally considered for  $F$ :

$$F_{log}(\Delta gdp_{t-d}) = \frac{1}{1 + \exp[-\delta_{log}(\Delta gdp_{t-d} - c_{log})]} \quad (12)$$

$$F_{exp}(\Delta gdp_{t-d}) = 1 - \exp[-\delta_{exp}(\Delta gdp_{t-d} - c_{exp})^2] \quad (13)$$

where  $\delta_i > 0$  ( $i = log, exp$ ), we obtain the LSTAR (Logistic STAR) and ESTAR (Exponential STAR) models, respectively. The parameters to estimate are given by the transition coefficient  $\gamma$ , the location parameter  $c_i$  ( $i = log, exp$ ) and, in practice, the delay  $d$ .

The model STAR stated above (equation 11 with the two specifications for  $F$ , 12 and 13) can be easily extended in order to consider more than two underlying regimes. If two additive transition regimes (three-regime model) are introduced in the model, we get the following specification:

$$\Delta gdp_t = [\alpha_0 + \beta_0 F(Z_{1t}) + \eta_0 F(Z_{2t})] + \sum_{i=1}^p [\alpha_i + \beta_i F(Z_{1t}) + \eta_i F(Z_{2t})] \Delta gdp_{t-i} + \epsilon_t \quad (14)$$

where  $F(Z_{1t})$  and  $F(Z_{2t})$  denote the two single indexes used in order to define the different regimes. In order to estimate a two (three)-regime SETAR model, the algorithm proposed by Hansen (1997) is employed.<sup>38</sup>

Non-linear least squares (NLS) estimates of the 2-regimes SETAR model imply that the regression function are split into two states, depending on whether the percentage change of real GDP (lagged differently according to the model) is higher or lower than the value estimated for  $\gamma$ . Since estimates of the threshold are in most cases near zero,<sup>39</sup> regime two can be seen as a recessionary state. For all series, our tests reject the null hypothesis of linearity, result that suggests that the SETAR specification is appropriate.

As far as the parameter estimates of the SETAR model are concerned, we observe that, for Canada, in both regimes all coefficients are statistically different from zero. This implies that the real GDP growth can be described, in both states, as a persistent process. Since for Germany (and Italy) in regime two (one), all autoregressive coefficients are near zero, series for these countries can better be described by a random walk process. On the other hand, for France, the intercept and the autoregressive coefficients in both regimes are all positive, the real GDP changes are characterized by a positive serial correlation and a slight positive drift.

<sup>38</sup> To notice that both in the 2-state and 3-state cases, the estimated residual variance is allowed to be different across the regimes. Even in the SETAR model framework, no statistically significant (at the 5% level) autoregressive terms (and similar across regimes) are eliminated from the regressions (see Potter, 1995).

<sup>39</sup> However, while the estimate is negative for Germany (-0.0027), for U.K. and the U.S. it is equal to 0.0187 and 0.0168, respectively.

For the three-regime case, the different phases describe economic contractions, moderate and high economic growth, respectively. Nonetheless, for all countries with the exception of Germany, the estimates of the two thresholds are very close. It follows that the model does not enable us to distinguish between the latter two phases.

STAR models are estimated by using the following procedure. The order of the autoregression,  $p$ , is chosen according to the AIC. The delay parameter ( $d$ ) of the STAR model is estimated by NLS by means of a grid search procedure directed to minimize the residual sum of squares. The null hypothesis of linearity for different values of  $d$  (the delay parameter) is then tested.<sup>40, 41</sup> For all countries, a high value associated to  $\gamma$  is representative of the fact that there is a rapid transition from one regime to the other.<sup>42</sup> Therefore, SETAR and STAR model are defined to be very similar. Another noticeable feature of the results is the huge standard deviation associated to the estimate for  $\gamma$ : this denotes that estimates are not accurate when the value of the threshold variable is close to  $c$  and the function  $F$  increases rapidly. Furthermore, we may argue that, for all countries, the parameter shifts in the constant term and autoregressive coefficients that occurs across the two regimes can not be defined as statistically significant.

To conclude, although satisfactory results are obtained by using SETAR and (in part) STAR models,<sup>43</sup> a graphical analysis of residuals is useful in order to assess the benefits of these nonlinear model in describing the behavior of the series during the negative phases of the business cycle. A slightly better in-sample fit for MS models (and, in particular, during the recessionary episodes) allows us to argue that MS specifications seem to be appropriate tools to be used in order to describe the nonlinear behavior of output.

## 5.2 Effects of oil shocks

The six MS models briefly presented in Section 4.3.1 are estimated with the Expectation-Maximization (EM) estimator described in Hamilton (1990 and 1995) for each of the G-7 countries using the seven alternative specifications of oil price shocks illustrated in Section 3 (a total of 294 different MS regressions).<sup>44</sup> Following our model selection strategy outlined in Section 4.2, we are able to select the best model in detecting the business

<sup>40</sup> This framework leads to results that are only slightly different from those obtained by considering the two-step procedure proposed by Teräsvirta (1994) and Teräsvirta and Anderson (1992). In particular, the procedure adopted allows us to select smaller values of the delay parameter  $d$ . According to economic intuition, it is difficult to imagine that economic variables begins to adjust to a shock after very long lags (see Taylor et al., 2001).

<sup>41</sup> A sequence of tests of nested hypotheses is carried out in order to choose between the LSTAR and ESTAR specification. While for France and Japan an ESTAR model is selected, for Canada, the U.K. and the U.S. a LSTAR specification has to be preferred. However, we are not able to estimate the models for the last two countries because of convergence problems. Therefore, results from ESTAR models are presented. Finally, for Italy and Germany, the null hypothesis of the linearity test is rejected.

<sup>42</sup> To notice that, according to Teräsvirta (1994) and Teräsvirta and Anderson (1994), estimates of the exponent of  $F$  have been standardized by dividing by the factor  $\hat{\sigma}(rgdp)$ .

<sup>43</sup> Together with simple AR models.

<sup>44</sup> The main features of each specification are reported in the Appendix. The working paper version of the article presents a more complete analysis of the results.

cycle features of each country. Empirical details on the selected models are presented in Table 2. Figure 1 (panel *a* to *g*) provides a diagnostic evaluation of the selected model for each country. In particular, we analyze the behavior of the regime probabilities, and the dynamics of actual values, fitted values and residuals. We also compute the probability of duration of each regime, and we present the plots of the cumulative probabilities of duration for each regime against the duration of that regime (predicted *h*-step probabilities). This section is devoted to the presentation and discussion of our empirical findings for each country under analysis.

As far as the Canadian business cycle is concerned, in order to investigate whether oil shocks are able to increase the accuracy of MS regression models, we have estimated a MSM specification with three regimes, a fourth-order autoregressive component and a four-lag augmentation on the exogenous oil prices changes ( $\Delta roil$ ).<sup>45</sup> However, this model does not achieve any significant improvement over the MSM(3)-AR(4) specification, according to a conventional LR test. On the other hand, significant improvements are obtained with the introduction of *oil\_regime*, *NOPI* and *oil\_vol* in the regressions. However, the best econometric results are obtained by using the definition of oil price increases ( $\Delta o^+$ ) in the MSM(3)-ARX(4) model (see Table 2 and Figure 1 panel *a*). The null hypothesis of validity of the MS(3)-AR(4) specification is rejected at 5% (the likelihood function value increases from 493.01 to 499.63). The second and the fourth coefficients of the distributed-lag component of oil shock variable are negative and statistically significant at 1%, while the first and third coefficients are positive, but not statistically different from zero. With regard to the autoregressive structure of the model, four lags are needed to capture the dynamics of real GDP. The transition probabilities ( $Prob(s_t = 1 | s_{t-1} = 1) = 0.61$ ) and ( $Prob(s_t = 2 | s_{t-1} = 2) = 0.96$ ) suggest the presence of important asymmetries in the business cycle. Regime 2 (i.e. moderate growth phases) is found to be the most persistent. The average duration of each regime supports this conclusion: while regime 2 is estimated to last on average 27.27 quarters, the average duration of a recession is 2.55 quarters. Conversely, high growth periods tend to be very short-lived, with an expected duration of 1.73 quarters.

The introduction of a specification that describes important changes in oil prices (namely, net oil price increases) is able to restore a statistically significant relationship between oil shocks and the economic activity for three countries (Germany, Japan and the U.S.). For Germany, the role of oil shocks is assessed with different MSIAH specifications with three states.<sup>46</sup> According to our results the inclusion of oil in the MS specifications seems to be appropriate. If we include positive oil price changes ( $\Delta o^+$ ) and net oil price increases (NOPI), we are able to describe the first regime as a zero-growth period. Results obtained by using the NOPI variable<sup>47</sup> suggest that oil price shocks have significant economic effects, in particular during “low-growth” and “high-growth” periods.

<sup>45</sup> In general, we indicate models with oil exogenous with the notation MS(*m*)-ARX(*p*), where *m* and *p* are, respectively, the number of regimes and the number of lags on oil shock variable (four).

<sup>46</sup> Other univariate models present good statistical properties. In particular, meaningful empirical results are obtained by considering two-regime MSMH models.

<sup>47</sup> In this case the value of the log-likelihood function is 469.80.

Parameter estimates suggest that, during expansions, oil shocks have negative, quasi-simultaneous effects that tend to last for a limited number of periods. During highly recessionary phases, oil shocks affect the economic system only gradually. Moreover, switches from one regime to another have a clearer economic meaning. The first regime well approximates the dates of recessions as reported by ECRI (1973-1975, 1980-1982, 1991-1994 and 2001-2003; see Table 1). Regimes 2 and 3 describe moderate and high growth phases. According to the computed ergodic probabilities, the dominant regime is the second (the value of the corresponding probability is 55.36%). At the same time, the transition probabilities ( $p_{11} = 0.26$ ,  $p_{22} = 0.56$  and  $p_{33} = 0.18$ ) signal the presence of important asymmetries in the business cycle. Regime 2 is found to be the most persistent, which is also confirmed by the average duration of each regime. While regime 2 is assumed to last 15.36 quarters on average, the average durations of a low-growth rate and an expansionary phase are 8.33 and 4.02 quarters, respectively (see Table 2 and Figure 1 panel c).

With regard to Japan, results on the importance of oil shock variable in a univariate MS-AR model confirm that, if we start with the MSMH model, oil price shocks affect the mean of the process. More specifically, the introduction of asymmetric specifications of oil price shocks improves the log-likelihood function. In case of NOPI, the maximum values of the likelihood function increase from 445.75 to 450.35. Therefore, according to standard LR tests, we reject the null hypothesis of no oil shock effects at 5% significance level. An examination of the coefficients of the three means, which are all statistically significant, shows the presence of switches in output growth between the three different states. In regime 1 (recession regime), output growth per quarter is equal to -0.82%, on average, while in regime 2 the average growth rate is equal to 0.69%. In regime 3 (i.e. high growth regime) Japan's average growth rate amounts to 1.53%. A single autoregressive term is sufficient to describe the autocorrelation structure of the GDP series. Coefficient estimates suggest that oil shocks (NOPI variable) have a delayed negative impact on real GDP growth. While the second coefficient is positive and not statistically significant, the other three coefficients are negative, although only the fourth is statistically different from zero. Results from the estimated transition probabilities suggest that regimes 2 and 3 are highly persistent. During a moderate growth phase, GDP is most likely to remain in regime 2 (estimated probability equal to 88.93%). On the contrary, the probabilities that the series switches from regime 2 to regimes 1 or 3 are very low (equal to 4.45% and 6.60%, respectively). Finally, the probability that GDP changes directly from a recessionary regime to a high growth regime is virtually identical to zero. Results on the expected duration of each regime confirm the information provided by the transition probabilities. The expected duration of regime 2 is considerably longer than the duration of either regime 1 or regime 3. If the economy is in state 1 (recessionary phase) at time  $t$ , it will maintain this position for 1.91 quarters, on average. On the other hand, moderate growth and high growth phases are expected to last on average 9.03 and 7.97 quarters (see Table 2 and Figure 1 panel e).

Finally, for the United States, when we augment a MSMH(3)-AR(4) model with different oil shock specifications, we obtain mixed empirical findings.<sup>48</sup> If oil price changes and *oil\_disr* are used as proxies for oil shocks, no significant improvements in the ability of the model to detect the business cycle characteristics are achieved.<sup>49</sup> Conversely, better results are found if we consider the oil price volatility as measured by *oil\_regime*, *oil\_vol* and NOPI. In the latter case (Table 1 and Figure 1 panel *g*), for instance, the value of the log-likelihood function increases from 477.36 to 482.27. According to this specification, all coefficients on the oil variable are negative, with three out of four coefficients statistically significant.<sup>50</sup> The transition probabilities associated with each of the three regimes point out that the second regime is highly persistent, with  $Prob(s_t = 2 | s_{t-1} = 2) = 0.88$ . These estimates imply that the average duration of the moderate growth regime is 8.58 quarters. In contrast, the average durations of the recessionary and high-growth regimes are 3.42 and 2.79 quarters. The recessionary state shows a relative high probability to be followed by a high growth period ( $Prob(s_t = 3 | s_{t-1} = 1) = 0.14$ ), while the probability of an expansion to be followed by a recession is 0.13. The ergodic probabilities imply that the economy would spend about 62.40% of the time spanned by our sample of data in the second regime (i.e. high-growth). In contrast, regime 1 and regime 3 have ergodic probabilities of 17.30% and 20.30%, respectively. Finally, another relevant feature of this model is the significant variability in the residual standard errors across different regimes. These results provide us with a more detailed interpretation of each single regime. Recessionary states show a strong increase in the variability of the standard errors, which reflects the view that recessions are less stable than expansions. On the other hand, moderate growth rate periods are characterized by relatively smaller residual standard errors.<sup>51</sup>

For the remaining three countries (i.e. France, Italy and the U.K.) the introduction of a measure of oil price volatility as a proxy of oil shocks seems to be appropriate. From the previous univariate analysis for real GDP, the model which seems to have the best statistical properties in order to describe the business cycle of France is represented by the MSMH(3) specification. Parameter estimates and the regime classification performance of the model significantly improve by introducing asymmetric specifications of oil prices. For instance, a MSMH(3) model which includes *oil\_vol* is able to detect the main slowdowns in the last 30 years of the French economy. Its three mean-parameters are statistically significant and describe low, moderate and high growth periods, respectively. All coefficients associated with the oil shock specification are negative with the second and fourth not statistically different from zero. The transition probabilities suggest that the third regime is the most

<sup>48</sup> Our analysis is not substantially different from that of Clements and Krolzig (2002). On the other hand, Raymond and Rich (1997) explore the relationship between oil price shocks and postwar U.S. business cycle fluctuation in the framework of a two-regimes MS model.

<sup>49</sup> For instance, regime 2 is very persistent and captures the second part of the sample.

<sup>50</sup> A MSMH(3)-AR(0) model which includes *oil\_vol* is more appropriate from a statistical viewpoint, nonetheless this specification is not able to justify the two most recent recessions in the U.S. economy.

<sup>51</sup> Our results are in line with those obtained by Clements and Krolzig (2002). However, contrary to our findings, their empirical evidence is against the conventional wisdom that recessions are more violent than expansions.

persistent and is frequently followed by regime 1 ( $Prob(s_t = 1|s_{t-1} = 3) = 0.11$ ). When the economy is in regime 2, there is a high probability that it switches to regime 1 ( $Prob(s_t = 1|s_{t-1} = 2) = 0.20$ ). The average durations of the three regimes are 2.85, 3.09 and 8.96, respectively. Regime 1 and 3 are characterized by higher volatility, since the associated standard error are larger (see Table 2 and Figure 1 panel *b*).

For Italy, we limit the study of the effects of oil shocks on economic growth to the improvements achieved by the MSIAH model<sup>52</sup> with different exogenous oil shock specifications. From a statistical perspective, significant gains are obtained by introducing asymmetric specifications of oil price changes. In particular, if we concentrate on the ability of the model to offer a meaningful regime classification, the model which includes oil price volatility (*oil\_vol*) seems to outperform its competitors. Since the LR test is equal to 40.04, the introduction of the oil price variable is statistically relevant at any significance level. Oil shocks seem to affect primarily high growth periods and low growth phases. In regime 1, the third and fourth coefficients on oil lags are negative, with the latter being statistically significant at 1%. In regime 3, while lags one and four are both negative and statistically relevant, the second and third lags are both positive with the third statistically different from zero at any significant level. This model predicts that low growth rate phases and expansions last on average 2.21 and 3.76. Conversely, regime 2 is highly persistent and exhibits an expected duration of expansions that is remarkably longer than the duration of recessions and of high growth periods (i.e. 25.64 quarters). An inspection of the computed transition probabilities confirms the relative instability of the recessionary regime (see Figure 1 panel *d*). Actually, the probability of observing a recession which lasts for more than 5 quarters is less than 5%. The persistence of a moderate growth rate phase is high, although the probability that the economy falls in a recessionary state is not negligible. As in Germany, a high growth regime tends to be followed by a recessionary phase more often than a phase of moderate growth.

Finally, for the U.K., we have considered MS models with exogenous oil shocks also for U.K. If we include four lags of the NOPI variable and of the two measures of oil price volatility to describe the conditional mean of the process, we obtain results that do not differ substantially from those obtained by Holmes and Wang (2003).<sup>53</sup> In comparison with the univariate specification, these models<sup>54</sup> lead to a significant improvement in the respective likelihood functions.<sup>55</sup> When the oil price shocks are measured by *oil\_vol*, all lags are negative, and the first is strongly significant. These results suggest that oil shocks have a quasi-instantaneous impact on

<sup>52</sup> Univariate analysis for real GDP growth suggests that MSIA and MSIAH models yield the highest value for the log-likelihood function. However, while the MSIA model captures as a low-growth regime only the 1970s recessions and describes the regime two as “high persistent”, the MSIAH model does not capture the fact that recessions are more volatile than expansions.

<sup>53</sup> However, in contrast to their analysis, our framework does not consider the possibility to model the transition probabilities - see Section 4.1 - but allows for a more detailed modeling strategy.

<sup>54</sup> As well as in the case of the introduction of the *oil\_regime* specification.

<sup>55</sup> The LR statistics are 25.12, 14.05 and 33.72 for the oil shock definitions NOPI, LNR and *oil\_vol*, respectively. Since these tests are  $\chi^2$ -distributed with 4 degrees of freedom, in each case we can reject the univariate specification with no oil shocks at any significant level. The coefficients of the NOPI variable are positive and statistically significant for the first and fourth lags. The third lag is negative and statistically significant.



the mean equation for GDP growth. The estimated parameters for the second and third mean coefficients are both statistically significant, and denote moderate and high growth, respectively. Moreover, the time intervals 1973-1975, 1980-1982 and 1990-1991 are described as sluggish economic growth periods. According to this model, in the subsample 1970-1992, the U.K. economy switches from low growth rates (which characterize the early 1970s, as well as the periods 1974-1977, 1980-1982 and 1989-1992) to high growth rates. A remarkable feature of this model is that the last part of the sample (from 1993 to 2004) is described as being characterized by regime 2. The standard errors of the model depict the first regime as high volatile. On the other hand, regime 2 is characterized by lower volatility. According to the calculated transition probabilities, the probability that an expansionary phase is followed by a low-growth phase is high ( $Prob(s_t = 1 | s_{t-1} = 3) = 0.16$ ) (see Table 2 and Figure 1 panel *f*).

[INSERT TABLE 2 AND FIGURE 1 ABOUT HERE]

### 5.3 Econometric stability of the oil-macroeconomy relationship

Results obtained by using the technique outlined in Section 4.3.2 are reported in Tables 3 and 4 and in Figure 2. Table 3 shows that, when a different sample is considered (1980-2005), the economic effects of oil shocks diminish significantly for most of the countries considered (notably, Canada, Italy, Japan and U.K.).<sup>56</sup> Figure 2 shows graphically the outcome of recursive estimates. For Canada, results suggest that, if the first part of the sample is considered (“fixed starting observation, variable ending observation” exercise), the effects of oil shocks remains statistically significant. However, if estimates are carried out by changing the starting observation, we can notice that the significance of oil shock variable decreases over time. In particular, if the first two oil shocks are excluded from the sample, coefficients are not longer statistically significant at any level.

For France, the two figures show that, if the oil shocks of the seventies and eighties are considered, the oil shock variable remains statistically significant.<sup>57</sup> Similar results are obtained for Germany. If the sample does not include the early 1970s, the oil shock variable coefficient is not statistically different from zero at any significance level. In particular, the first figure shows that for all samples the oil variable is useful in order to explain the behavior of business cycle. To notice that the second oil shock has been able to restore a significant role for the exogenous variable.

The decreasing role of oil over time in explaining Italy’s real GDP growth can be seen from both figures. When the last part of the sample is considered, it results that the oil variable is no longer significant (see Figure 2 panel *d1*). The second graph shows the importance of the oil shocks of the seventies and of oil price declines during the mid-1980s. This evidence seems to confirm the existence of asymmetric effects of oil shocks.

<sup>56</sup> For France, Germany and the U.S. the coefficients remain statistically significant at the 5% level.

<sup>57</sup> Starting from the 1987q2-2005q1 sample the oil variable is no longer statistically significant at the 5% level.

Results for Japan shows that the oil shocks-macroeconomy relationship can be restored only if the full sample is considered.<sup>58</sup> Oil shocks seems to be an important factor in order to explain the 1973-1975 and 2000-2003 recessions. However, there seems to be an indirect effect of monetary/fiscal policy in affecting this outcome (for more details refer to Section 6).<sup>59</sup>

As for Germany, U.K. and the U.S. are concerned, if the sample does not include the early 1970s the oil shock variable coefficient is not statistically different from zero at any significance level. For U.K. there seems to be a break of the oil-macroeconomy relationship if the sample includes the 1998-1999 years. That view seems plausible since the economy experienced an expansionary phase despite the increase in oil prices. For the U.S., a diminishing impact of oil shocks on economic activity since 1980 is documented, for instance, in Hooker (1996).<sup>60</sup> Moreover, results for the U.S. suggest an insignificant role of oil shocks in explaining the recession that hit the U.S. economy in 2001: the oil shock variable loses part of its explanatory power if the sample is extended in order to consider the 2002-5 years.

[INSERT TABLE 3 AND FIGURE 2 ABOUT HERE]

Table 4 reports results of the structural break analysis implemented according to Section 4.3.2. Tests of differential intercepts are reported together with tests which assume common intercepts but differential slope coefficients. Finally, results of tests that assume both changing intercepts and changing slope coefficients are shown.<sup>61</sup> According to the results, for some countries (i.e. France, Germany and Japan) there seems to be a structural break in the relationship between oil and the real GDP growth starting from the mid- and late-1970s, for Canada, Italy and U.K. the relationship between oil and GDP broke down after the second oil shock (1979). For the U.S., there is evidence that the economic impact of oil shocks during the last experience (2001) has been lower than previous episodes. This accords well with the results of the recursive estimation of the benchmark model.

To conclude, results confirms that for almost all countries, the full sample can be divided in two distinct periods according to whether or not there is evidence in favor of causality from oil shocks to economic activity. In particular, the predictive power of the oil variable is highest during the first part of the sample.

Hence, a structural analysis of the regime-switching models is argued to indicate that the major industrial economies has experinced a progressive decrease of the effects of oil shocks on business cycle behavior (see Section 6).

[INSERT TABLE 4 ABOUT HERE]

---

<sup>58</sup> However, only at the 6% significance level.

<sup>59</sup> In an econometric analysis on the determinants of real activity in Japan, Lee et al. (2001) find that monetary tightening induced by oil price increases is responsible for 30/50% of the total negative effects of oil price shocks.

<sup>60</sup> According to Hooker (2002), a change in the responses to inflationary pressures by the Federal Reserve is seen as responsible for the structural break in the oil-macroeconomy relationship (see also Section 6).

<sup>61</sup> In the fourth column, results of tests of differential slope coefficients only for oil variable are reported for comparative purposes.

## 5.4 Simultaneity issue

In this section we show results that try to address the following question: what can we add to previous findings if the causal relationship which goes from the international business cycle to the oil market (simultaneity issue) is also taken into account? Results of the models estimated for an aggregate measure of real GDP for the G-7 countries variable ( $\Delta gdpG7_t$ ) and for the real GDP growth for the U.S. are reported in Table 5. Figures 3 and 4 report the smooth and filtered probabilities of being in a determined regime together with the actual, fitted and standardized residuals of the estimated models.

As far as the  $\Delta gdpG7_t$  variable, the MS model that presents the best econometric properties<sup>62</sup> is a MSM-VAR model with three regimes and five autoregressive terms (see Table 5). Asymmetries in the oil-macroeconomy relationship are described by the oil price increases specification (see Mork, 1989). An analysis of the coefficients suggests that a high mean for the oil shock specification tends to be associated to low growth rates for the  $gdpG7_t$  variable. Viceversa, regimes of moderate positive oil price changes coincide with phases characterized by higher growth rates for real GDP. Since, in the real GDP equation, three out of five coefficients on oil prices are negative and statistically different from zero, we may argue that a negative influence of oil shocks on the business cycle of the G-7 countries exists even if an aggregate measure is employed.<sup>63</sup> On the contrary, no coefficient on real GDP in the oil price equation is statistically significant. Consequently, the hypothesis that changes in real GDP do not cause changes in oil prices cannot be rejected. An analysis of regime properties (regime probabilities, see Figure 3) establishes that economic phases dominated by both high oil price increases and low economic growth tend to be short-lived (1-2 quarters).

The G-7 output growth process is, also, adequately well described by another model which assumes switches in the mean of the series and uses as oil shock specification the NOPI variable (MSM(3)-VAR model). Even in this case, the fact that all coefficients on real GDP in the oil price equation are not statistically different from zero<sup>64</sup> is representative of the absence of reverse causality from output growth to oil prices.<sup>65</sup> As far the U.S., a model which is found to give a good description of business cycle features is a MSM-VAR specification characterized by 3 regimes. As in the case of the  $\Delta gdpG7_t$  variable, we employ as oil shock specification the variable represented by positive oil price increases (see Table 5). From an analysis of the coefficients of the three means it results that regimes of high oil price increases coincide with phases of low economic growth. On the

<sup>62</sup> Following the model selection procedure outlined in Section 4.2.

<sup>63</sup> To notice that if we consider the sample 1980-2005 a diminishing impact of oil shocks on G-7 aggregate business cycle is shown to exist.

<sup>64</sup> On the other hand, all two coefficients on oil variable in the equation are negative and statistically significant.

<sup>65</sup> Other models which provide a sufficient adequate representation of the statistical features of the business cycle for the G-7 countries are given by MSIA (MSIAH) and MSM-VAR specifications where oil shock proxies are represented by the *oil\_disr* and *oil\_vol* variables, respectively. From an analysis of coefficients we can view, at least in part, a role of macroeconomy in explaining oil market conditions (in particular, during regimes of low economic growth). However, these models are not able to depict the 2001 period as a regime of economic slowdown.

other hand, during periods of moderate oil prices increases, the U.S. economy tends to experience expansionary cycles. With regard to the coefficients of the two equations, the oil specification parameter in the GDP equation is negative and highly statistically significant. The impact of economic activity on oil prices is no statistically different from zero.<sup>66</sup> An analysis of regime probabilities suggests that the 1974-1975, 1980, 1981-1982 and 1990-1991 periods can be described as phases of high oil price increases and low economic activity (Figure 4). Expansionary phases tend, on the other hand, to be longer (26.62 quarters). Similar results are obtained if alternative oil shock specifications are employed (i.e., simple oil price changes, net and scaled oil price increases). However, in the case of oil price changes, the coefficient on oil specification is no statistically relevant at any significance level, suggesting that an asymmetric oil-macroeconomy relationship does exist. Finally, we are not able to establish, in all these models, a link between economic activity and oil prices during the 2001 episode (i.e., it can not be described as a phase where both decreasing economic growth rates and important positive oil price changes occurred).

[INSERT TABLE 5 AND FIGURES 3 AND 4 ABOUT HERE]

These results are interpreted as evidence of a decreasing role over time of developed countries to affect world oil prices. In fact, we may observe that the pattern of oil demand have recently been influenced by new conditions on international energy markets (for instance, increase of financial speculation and emergence of new operators on the markets).<sup>67</sup>

## 6 Economic implications and future research

This section deals with the following issues: What are the economic implications of the structural breaks issue. Are the process of international outsourcing together with the decrease in energy intensity the main factors that explains a diminishing impact of oil shocks on the macroeconomy? What can we say about the impact of oil shocks on the business cycle if the effects to/of other macroeconomic variables (interest rates, inflation rate and government expenditure) are taken into account? What are the future avenues of empirical research? This section, in particular, would like to argue that structural changes in the economy (as far as creation of

<sup>66</sup> Our conclusions seem to be robust over different number of lags included in the vector autoregressions. Furthermore, results are in line with previous finding in the literature. According to Sadorsky (1999), for instance, while oil price changes have affected U.S. economic activity, oil prices tend to have been little affected by U.S. economic variables.

<sup>67</sup> As this second point is concerned, the increase of oil prices in 1999-2001 is argued to have been determined by buoyant demand for energy by high growth countries. While in 1970 China, India and Brazil consumed 3.31% of the world's oil, in 2004 their total consumption of oil has been equal to 13.31%. On the other hand, during the period 1970-2004, G-7 countries' share of world's oil consumption has fallen from 61.14% to 44.45%. During the same period, U.S. share of world's oil consumption has decreased from 31.40% to 25.10%. (Source: Energy Information Agency, U.S. Department of Energy). Other evidence of the emergence of this trend is proved by the fact that the Asian crisis of 1997-1998 has been followed by a decrease in oil prices (Barsky and Kilian, 2004).

value added and oil consumption/energy intensity are concerned and stabilization policy carried out by fiscal and monetary authorities) all seem to have had role in radically reducing short-term economic implications of oil shocks.<sup>68, 69</sup>

## 6.1 Some stylized facts on the business cycle of the G-7 Economies

A first descriptive analysis on the business cycle of the G-7 countries is concerned with how economic fluctuations have changed across different time periods by considering standard deviation of percentage changes for real GDP growth and oil prices across different subsamples. On the basis of the pattern of oil prices, three sample periods are considered: 1970-1980, 1980-1990 and 1990-2005. During the first period, oil market conditions have been dominated by violent shocks (i.e. 1973-74 - oil embargo - and 1979-80 - Iran revolution, Iran/Iraq war). The second phase corresponds to a period characterized by decreasing oil prices. Finally, during the third period, oil prices have seen an irregular sequence of increases and decreases. After the short episode of the increase in prices due to the invasion of Kuwait by Iraq (August 1990), prices remained stable or even decreased (1997-1999). Since 1999 changed market conditions<sup>70</sup> can be argued to have driven prices up.

One finding that stands out from an analysis of this simple descriptive statistics is the fact that average volatility has decreased over time. Standard deviation of percentage changes for real GDP growth and industrial production for the first subsample is approximately equal to 1.30% and 2.26%, respectively (average value for the G-7 countries). Then standard deviation of the two series have decreased to 0.89% (1.60%) during the 1980-1989 period and to 0.75% (1.34%) during the last subsamples. A single-country analysis confirms this observation. In particular, reduction of business cycle fluctuations has been robust in U.K. and the U.S..

In addition, interest rates and government consumption expenditure volatility has steadily decreased across the three subsamples. An analysis of standard deviation of percentage changes of oil prices shows that the 1970-1980 period has been significantly more volatile than the other two subsamples. However, after 1990, differently from the macroeconomic variables, volatility has again increased (from 12.70% to 14.16%).<sup>71</sup>

A second analysis of the data on business cycle features focuses on the dates of peaks and troughs in economic activities and on determination of oil market regimes. Useful indicators are the length of recessions and ex-

---

<sup>68</sup> From the descriptive analysis that follows, our purpose is not to deduce a trend of the oil-macroeconomy relationship over time. Given the short-span of the data, we aim at detecting stylized facts on the important changes that have occurred in this relationship.

<sup>69</sup> The importance of the reduction in oil intensity, better strategies carried out by central banks and more flexible economies (in particular, as far as labour markets are concerned) have been recently stressed as main factors of a decreasing macroeconomic effects of oil shocks by other empirical work (see, Blanchard and Gali, 2007 and Nordhaus, 2007). See also The Economist (2007).

<sup>70</sup> As we have already noticed, combination of a booming world oil demand driven by rapid growth in energy consumption (most notably from high-growth countries, China and India, *in primis*) and tight supply conditions.

<sup>71</sup> According to Stock and Watson (2002) an important part of the reduced volatility of U.S. output growth can be attributed to smaller macroeconomic shocks (in particular, from monetary and fiscal policy, factor productivity and commodity prices). That view seems to hold even for the group of seven countries.

pansions defined as time from peak to trough and time from trough to next peak (expansions) for each peak, respectively and the total output loss of the economic downturn.

One interesting finding is that recessions have not become noticeably shorter after the 1970s.<sup>72</sup> The average length of the recessions of the 1970s ranges from 10.50 months (France) to 28 months (Germany). Recessions that characterized the period 1980-2005 last in average from 8 months (2001 recessionary episode in the U.S.) to 40 months (1991-1994 recession in Germany). For the G-7 countries the average length of recessions during the three subsamples is 16.81, 21.88 and 22.21 months, respectively.<sup>73</sup> As far as the output loss is concerned, in these developed countries significant falls in output occurred not only during the first subsample. Analogue decreases were experienced even after 1980.

The issue raised by our analysis can be rapidly summarized as follows: the economic implications of oil shocks can not be completely understood without considering the structural changes that characterized the developed countries and the overall stabilization process implemented by macroeconomic policy. In fact despite an ambiguous oil price pattern, volatility of output variables has fallen over time while, in average, recessions length has not decreased. Finally, severe recessions happened in all three different subsamples.

## 6.2 Energy efficiency improvements

Since the mid-1980s both the behavior of oil prices and the structure of the economy (most notably for the developed countries) with respect to the energy intensity of oil have been characterized by considerable changes in their fundamentals (see Mork, 1989 and Hooker, 1996, *inter alia*).

A look on data on energy efficiency show clearly how the structure of the economy regarding oil as an input factor has changed over the last decades. Energy intensity as measured by final consumption divided by total GDP (in purchasing power parities) has decreased significantly in all the G-7 countries.<sup>74</sup> As far as the consumption of oil products in the industry sector is concerned, for most of the countries considered, we can observe that energy intensity (computed by dividing industry oil consumption by the Gross Value Added of the sector) has significantly declined during the 1970-1986 period. Thereafter, with the exception of the U.S., it has not showed further relevant reduction. Energy intensity in the transport sector decreased over the full sample in Canada and the U.S. . By contrast, intensity has risen in Italy. In Japan, since 1985, improvements in energy efficiency have been offset by “consumer preference for larger cars and the increase in driving distances” (IEA, 2004).

Despite the increase in the oil consumption in the transport sector in both absolute and percentage terms, energy

---

<sup>72</sup> As far as the U.S. business cycle is concerned, see, for instance, Romer (1999).

<sup>73</sup> Another noticeable result is that expansionary phases length seems to have increased over time. For the full sample of countries, expansionary regimes last in average 84 and 94.50 months during the 1970s and 1980s respectively.

<sup>74</sup> From 1990 to 2004 energy intensity has dropped by 22.5% and 20.3% in U.K. and the U.S., respectively. For Japan and France this decrease has been relatively more modest (respectively, -4.7% and -5.08%). For Italy, over the last twenty years, energy intensity has remained roughly constant (-0.75%).

intensity of GDP with respect to oil products has declined in all the G-7 countries (see Figure 5). However, in the U.S. and Germany, between 1990 and 2004, oil intensity has fallen by 18.3% and 23.5% respectively. On the other hand, while in Italy and Canada it has dropped only by 9.5% and 11.2% over the same period, in Japan since the mid-1980s there have been no significant improvements (it has remained constant at a level of 0.06 ktoe/\$95ppp, however, well below the average of the G-7 countries).

[INSERT FIGURE 5 ABOUT HERE]

Oil intensity has fallen significantly, we argue, because of different factors.<sup>75</sup> Structural shifts toward less energy intensive production methods (materials) account for a significant fraction of the reduction in manufacturing energy use per unit of output.<sup>76</sup> A noteworthy fact is the shift of jobs across countries which has happened according to the globalization effect of recent decades. These structural changes are often associated with the decision by firms located in developed countries to move “non-skill-intensive” activities abroad. The process of international outsourcing, in particular, represents a direct measure designed to face “import competition from low-wage countries” (Feenstra and Hanson, 1996). An immediate consequence of the rapid phase of globalization which is characterizing world trade is a massive integration of economic activities and a gradual change in the proportions different sectors/industries contribute to a country’s income.<sup>77</sup>

All in all, since 1970 there has been a consistent change in the fuel mix which partially reflects fuel substitution induced by price increases and environmental issues. Furthermore, structural changes in the G-7 countries economies as well as in the international context (because of new phenomena such as the outsourcing of industrial processes) have led to a significant reduction in energy use. Finally, significant energy savings have arisen also from the achievement of lower energy intensities: technological advances which have characterized single individual sub-sectors can be argued to be a dominant factor.

### 6.3 The role of monetary and fiscal policy

In this section, the record of monetary and fiscal policy actions since 1970 is examined. How macroeconomic policy has changed before economic cycle peaks is considered. An attempt to explain the sources of these policy changes in the light of inflation pressures and output growth rates is, then, given. Table 6 reports the behavior

---

<sup>75</sup> To notice that the extent of the contribution of these factors to the reduction in oil intensity changes from countries to countries.

<sup>76</sup> For a group of 11 OECD countries (Australia, Denmark, Finland, France, Germany, Japan, Italy, Norway, Sweden, U.K. and the U.S.) the International Energy Agency (IEA, 2004) estimates that, for the manufacturing sector, structural changes are responsible for about one third of the total reduction in energy intensity. For Japan and the U.S., in particular, this factor is estimated to have reduced energy use by about 1% per year on average. However, the impact of structural changes varied across countries; while the manufacturing sector structure has become less energy intensive in most countries, in a few energy (e.g. Norway) use has been driven up by structural changes.

<sup>77</sup> For instance, for the G-7 countries, the value added of industry decreased from 35.07% in 1971 to 25.27% in 2005. On the contrary, during the same period, the value added of the service sector increased from 62.21% to 73.20%.

of monetary and fiscal policy variables and macroeconomic variables during the eight quarters that preceded periods of economic recession as determined by NBER and ECRI.<sup>78</sup> The cumulative change of interest rates, government consumption expenditure, industrial production, inflation rate (average value of the period) and oil prices is considered. Phases of recessions and oil shocks, as defined on the basis of large increases of oil prices, are highlighted accordingly.

During the mid-1970s all countries but Canada entered in recession. However, while Germany was already in recession when the oil shock hit the world economy, the stagnation of Japan and the U.S. began just before the oil shock. As far as the policy implemented by monetary and fiscal authorities, it can be noticed how all countries were experiencing tight monetary policies in order to combat high (or at least increasing - as in the U.S.) inflationary pressures and dampen growth (industrial production was increasing in all countries). Another noticeable fact is that, in Italy and the U.S., the deflationary aim of monetary policy was accompanied by a restrictive fiscal policy: in these countries, government decreased their expenditure on consumption. In the other four countries, during the eight months that preceded the recession, government expenses increased. During the four quarters that followed the peak of economic activity, central banks of all countries but Japan reacted by loosening monetary conditions. Their effort was directed at mitigating the negative effects on growth due to the uncertainties generated by the external shock. In Japan, because of the huge increase of price level between 1973 and 1974 (8.9%), the central bank decided to implement a restrictive monetary policy exacerbating the decrease in production levels. Though the tight monetary policy by the U.S. central bank started three quarters before the date of the oil price increase, the Federal Reserve continued to restrict its policy, even in the following quarters, in response to the inflationary pressures induced by the shock (see Bohi, 1991 and BGW, 1997). Interest rates began decreasing after 3 quarters from the 1973 oil shock date.

Even after the second oil price shock, all countries considered (with the exception of Japan) experienced a phase of economic downturn. In few countries (notably, Canada, Germany and U.K.) recession was aggravated by a restrictive action carried out by both monetary and fiscal authorities. In Canada, Germany and U.K. the average increase of interest rates in the eight quarters before peak was 5.85, 2.96 and 0.80 basis points, respectively.<sup>79</sup> In the case of Canada we are able to establish a relationship between inflationary pressures and restrictive monetary policy responses. For the other two countries interest rates increased despite only marginally relevant rises in inflation pressures. This would suggest that monetary policy became restrictive in order to decrease output growth rates. In France, despite a high inflation level, both monetary and fiscal authorities implemented an expansionary policy (interest rates decreased while government expenditure increased). Recession was, therefore, relatively modest: it lasted only 10 quarters while the total output loss was 5.18 percentage points. Subsequent increases of interest rates, however, had the effect to induce another economic downturn (since

<sup>78</sup> The full set of results is reported in the Appendix.

<sup>79</sup> During the five quarters before peak the Bank of England raised interest rates by 6.66 basis points.



1982q1 to 1984q4).

As far as the U.S. are concerned, in late 1970s, Federal Reserve and government expenditure main concern was to reduce inflation.<sup>80</sup> Therefore, federal funds rate increased significantly (by 7.06 basis points). On the other hand, public expenditure decreased by 0.0087 percentage points. The U.S. were hit by another downturn only 12 months after the previous trough. Even in this case, we can notice that a significant increase of federal funds occurred three months before the peak (6.02 basis points). With regard to the measures of macroeconomic policy implemented during this period of recession, it can be argued that, because of inflation rates that were high by historical levels, all central banks of the G-7 countries responded to the concerns raised by the oil increase by tightening monetary conditions.

In the early 1990s, recessionary phases characterized all seven countries. Table 6 shows that the oil shock that followed the invasion of Kuwait by Iraq was only in part responsible for this economic crisis. For four countries (Canada, Germany, U.K. and U.S.), despite low inflation rates, monetary authorities were restricting conditions on the markets in order to dampen economic growth. Furthermore, in Germany, U.K. and the U.S., the increase in interest rates was accompanied by a fall in public expenditure. The average cumulative drop in the ratio of government expenditure to GDP in the eight quarters that precedes the peak of economic activity ranges from 0.0023 (U.S.) to 0.0196 (Germany). This denotes restrictive policy carried out also by fiscal authorities.<sup>81</sup>

A negative regime characterized the economies of France, Italy and Japan only 7 quarters after the 1990 shock. Understanding the causes of these downturns is puzzling. However, a look to the behavior of monetary and fiscal variables suggests that authorities responded to low inflation rate and stable economic growth by loosening conditions on the markets. During the period the preceded the recessionary regime, interest rates and government consumption expenditure were, respectively, decreasing and increasing. External inflationary and recessionary pressures, as proxied by increases in oil prices, were absent (oil prices declined in average by 36%). A possible explanation for such pattern is that the positive monetary and policy conditions may have only postponed the downturn that interested the other economies.

With regard to the response of monetary authorities to the economic recession a closer look at the data suggests that, for two countries (namely, Canada and the U.S.), the 1990-1991 oil shock did not translate into higher inflationary pressures. This fact together with a decreasing industrial production output suggest that the expansionary monetary policy was aimed at allowing a gradual return to stable economic growth. In these two countries, short-term interest rates decreased, respectively, by 4.26 and 2.52 basis points in the four quarters

---

<sup>80</sup> According to Clarida et al. (2000) after 1979 (during the "Volcker-Greenspan era") interest rate policy appears to have been more sensitive to changes in expected inflation. While before that date, the U.S. central bank is alleged to be highly accommodative toward controlling inflation, after Volcker was appointed as chairman of the Federal Reserve, the response to inflationary pressures became more aggressive.

<sup>81</sup> As discussed in Blanchard (1993), the oil price hikes had a role in affecting U.S. business cycle during the 1990-1991 business cycle. Uncertainties raised by the oil price hike are argued to have induced a drop in consumption expenditure.

that followed the oil shock. It can be argued that, as a consequence of this economic stimulus, the stagnation that hit these two countries was relatively modest.

A word should be spent in order to analyze the stagnation of Japan during the 1997-1999 period. This episode shows us how factors other than oil shock effects should have had a role in affecting the economies of developed countries during the last 20 years. Despite seemingly apparent expansionary monetary and fiscal policies, which were allowed by a slightly increasing industrial production and a situation of low inflation/deflation, the Japanese economy entered in recession in March 1997. As argued by Motonishi and Yoshikawa (1999) (among others), financial problems associated to the burst of a housing bubble were at work. While the collapse of asset prices negatively affected household consumption, “an extremely poor performance of corporate investment [and, in particular, for small firms] is the most important factor to explain the long stagnation of the Japanese economy” in this period. Since the value of collateral decreased, banks became reluctant to lend money. In other words, the main explanation of this downturn is that “a credit crunch caused by bad loans banks” occurred.

The G-7 countries experienced a new phase of economic slowdown during the 2001-2003 period, with three countries (Germany, Japan and the U.S.) hit by an economic recession. As Table 6 shows, the 2001 recession in the U.S. can not be viewed as a consequence of a monetary restrictive policy by the Federal reserve. In fact, during the 1999q1-2001q1 period, federal funds rate decreased by 0.20 basis point.<sup>82</sup> With regard to Germany, restrictive monetary and fiscal policy conditions (which should be added to the increase of oil prices since 1999q2) anticipated the fall in output that occurred during the 2001-2003 period. However, an argument which is often used in order to explain the recession of this period is represented by the growth in importance of a “causal mechanism linking cycle regimes” between the developed countries (Sensier et al, 2004). As far as Japan, financial imbalances that prevented the economic stimulus provided by expansionary monetary policy from functioning are again to consider. If we examine macroeconomic policy conditions in the aftermath of the 1999-2000 oil price increases in more detail, it appears that monetary policy has been tight in all seven countries. Despite the absence of inflationary pressures, interest rates increased significantly in the period.<sup>83</sup> Concerns about possible prospective increases of inflation may have caused central banks approach to business cycle to become restrictive despite a generalized evidence of considerably weak real growth.

[INSERT TABLE 6 ABOUT HERE]

We can conclude by arguing that a simple examination of data suggests that, despite relevant exceptions<sup>84</sup> monetary policy could have played a critical role in determining recessions. Furthermore, monetary policy

<sup>82</sup> As discussed in Stock and Watson (2003), the economic recession was due to the decision by U.S. firms to significantly reduce investments (especially in Information Technology). This decision had the effect to determine a reduction in manufacturing output. A collapse of stock market prices further exacerbated this phase of economic slowdown.

<sup>83</sup> This increase ranges from 0.11 (Japan) to 2.09 (France) basis points between 1999q4 and 2000q3.

<sup>84</sup> For instance, 1995-1997 economic recession in Japan and 2001 developed countries' generalized economic slowdown.

conditions are more likely to have determined recessions than fiscal policies. Rarely<sup>85</sup> have economic downturns been associated with decreases in public expenditure. The role of monetary policy responses on business cycle fluctuations is consistent with the view of “policy-induced recessions”<sup>86</sup> It seems that many of the responses of monetary authorities in the 1970s were motivated by concerns about inflationary pressures (due, mainly, to oil shocks). On the other hand, in many recessionary episodes, since 1980, oil shocks occurred in a context of already increasing prices and tight monetary policy stance. Evidence that the impact of oil shocks on consumer prices has fallen over time<sup>87</sup> seems to be consistent with the view of a decreasing role of oil shocks in affecting the business cycle of the G-7 countries.<sup>88</sup> To notice, however, that despite these conclusions on the pattern of fiscal and monetary policies during expansionary phases and on the role of oil shocks, the finding that macroeconomic policy had a role in determining recession is tricky and can be assessed only empirically. An analysis by means of multivariate econometric models of whether monetary policy and fiscal policy regime shifts may have generated a different oil shocks-macro-economy behavior over time is left as topic for future research.

## 7 Conclusions

This paper presents and discusses the empirical findings obtained by using different MS specifications for the statistical assessment of the business cycle dynamics for the G-7 countries. These models have been extended in order to verify if the inclusion of oil shocks as an exogenous variable improves the ability of each specification to identify the different phases of the business cycle for each country under scrutiny. The persistence of each economic regimes, as well as the ability of each MS model to detect the business cycle dates as described by widely acknowledged statistical institutions (i.e. ECRI and NBER) has been measured and assessed. Following the wide literature on this topic, we have considered seven different definitions of oil shocks. In particular, oil price changes, asymmetric transformations of oil price changes (i.e. positive oil price changes and net oil price increases), oil price volatility (that is, scaled oil price increases and standard deviation of oil prices), and oil supply conditions are the variables used in order to proxy oil shocks. The paper aims also at verifying whether the relationship between these two variables is stable from an econometric point of view or whether the economic consequences of oil shocks have decreased over time.

According to our econometric results, the null hypothesis of linearity against the alternative of a MS specification is always rejected by the data. Moreover, three-regime MS models typically outperform the corresponding

---

<sup>85</sup> In 12 out of 26 recessionary episodes.

<sup>86</sup> For a review of Fed monetary policy action and its effects on U.S. business cycle after 1919 see, for instance, Romer and Romer (1989 and 1994) and Romer (1999).

<sup>87</sup> For instance, the 1990-1991 and 1999-2001 oil crises seem to have been followed by either inflation rates or only marginal increases in consumer prices.

<sup>88</sup> As outlined in Section 2 the allegation that the monetary policy response to oil price have changed since 1970 is confirmed, for the U.S., in an empirical analysis by BGW (1997). In their analysis, the responses of short-term interest rates to oil price shocks are estimated across different subsamples.

two-regime specifications in describing the business cycle features for each country. Furthermore, when the statistical properties of simple AutoRegressive (AR), Self Exciting Threshold AutoRegressive (SETAR) and Exponential/Logistic Smooth Transition Autoregressive (ESTAR, LSTAR) models are compared to those of our benchmark models, results do not improve significantly. This allows us to conclude that specifications characterized by abrupt regime changes represent a robust tool a researcher should use if interested in obtaining statistically adequate representations of the output growth process.

As far as the oil shock effects on business cycle are concerned, we can draw the following conclusions: according to our model selection strategy, the introduction of different oil shock specifications is never rejected. In particular, models with exogenous oil variables generally outperform the corresponding univariate specifications which exclude oil from the analysis. In addition, positive oil price changes, net oil price increases and oil price volatility are the oil shock definitions which provide a more accurate identification of the switches between different economic phases. This result allows us to conclude that oil shocks effects tend to be asymmetric and depend on whether or not the price increases are simple corrections of past decreases (LNR, 1995). Results from an analysis of the stability of the coefficients suggest that the role of oil shocks in explaining recessionary episodes has decreased over time. Improvements in energy efficiency together with a better systematic approach to external supply and demand shocks by (in particular) monetary authorities are argued to have been responsible for the changing effects of oil shocks.

A last result is related to the issue of a simultaneous relationship between oil shocks and the economic activity. When the impact of G-7 aggregate growth on oil market conditions is considered and assessed empirically, econometric evidence suggests that the economies of these developed countries are not able to affect oil market conditions if the sample is extended in order to include the very recent oil price increases.

## References

- Abel A. B. (1992). Exact Solutions for Expected Rates of Return Under Markov Regime Switching: Implications for the Equity Premium Puzzle. *National Bureau of Economic Research*. Working Paper No 4110.
- Ang A. G., and Bekaert G. (1998). Regime Switches in Interest Rates. *Stanford University*. Research Paper 1486.
- Artis M., Krolzig H. M., and Toro J. (2004). The European Business Cycle. *Oxford Economic Papers*, **56**, pp. 1–44.
- Balke N. S., Brown S. P. A., and Yucel M. K. (2002). Oil Price Shocks and the U.S. Economy: Where Does the Asymmetry Originate? *Energy Journal*, **23**, pp. 27–52.
- Barsky R. B., and Kilian L. (2001). Do We really Know that Oil Caused the Great Stagflation: A Monetary Alternative (with comments). *National Bureau of Economic Research*. Working Paper No. 8289.
- Barsky R. B., and Kilian L. (2004). Oil and the Macroeconomy Since the 1970s. *Journal of Economic Perspectives*, **18**(4), pp. 115–134.
- Bernanke B. S., Gertler M., and Watson M. (1997). Systematic Monetary Policy and the Effects of Oil Price Shocks. *Brookings Papers on Economic Activity*, **1**, pp. 91–142.
- Blanchard O. J. (1993). Consumption and the Recession of 1990-1991. *American Economic Review*, **83**(2), pp. 270–74.
- Blanchard O. J., and Gali J. (2007). *The Macroeconomic Effects of Oil Shocks: Why are the 2000s So Different from the 1970s?* NBER Working Papers 13368. National Bureau of Economic Research, Inc.
- Bohi D. R. (1991). On the Macroeconomic Effects of Energy Price Shocks. *Resources and Energy*, **13**, pp. 145–162.
- Boldin M. D. (1996). A Check on the Robustness of Hamilton’s Markov Switching Model Approach to the Economic Analysis of the Business Cycle. *Studies in Nonlinear Dynamics and Econometrics*, **1**, pp. 35–46.
- Brown S. P. A., and Yucel M. K. (1999). Oil Prices and U.S. Aggregate Economic Activity: A Question of Neutrality. *Federal Reserve Bank of Dallas Economic and Financial Review (Second Quarter)*, pp. 16–23.
- Brown S. P. A., and Yucel M. K. (2002). Energy Prices and Aggregate Economic Activity: An Interpretative Survey. *Quarterly Review of Economics and Finance*, **42**, pp. 193–208.

- Brown S. P. A., Yucel M. K., and Thompson J. (2002). Business Cycles: The Role of Energy Prices. *Federal Reserve Bank of Dallas*. Research Department Working Paper 0304.
- Burbidge J., and Harrison A. (1984). Testing for the Effects of Oil-Price Rise Using Vector Autoregressions. *International Economic Review*, **25**, pp. 459–484.
- Cecchetti S. G., Lam P. S., and Mark N. C. (1990). Mean Reversion in Equilibrium Asset Prices. *American Economic Review*, **80**, pp. 398–418.
- Clarida R., Galí J., and Gertler M. (2000). Monetary Policy Rules And Macroeconomic Stability: Evidence And Some Theory. *The Quarterly Journal of Economics*, **115**(1), pp. 147–180.
- Clements M. P., and Krolzig H. M. (2001). Modelling Business Cycle Features using Switching Regime Models. *Department of Economics, University of Oxford*. Discussion Paper No. 58.
- Clements M. P., and Krolzig H. M. (2002). Can Oil Shocks Explain Asymmetries in the U.S. Business Cycle? *Empirical Economics*, **27**, pp. 185–204.
- Cognigni A., and Manera M. (2006). Oil Prices, Inflation and Interest Rates in a Structural Cointegrated VAR Model for the G-7 Countries. *Energy Economics*. doi: 10.1016/j.eneco.2006.11.001.
- Cunado J., and de Gracia F.P. (2003). Do Oil Price Shocks Matter? Evidence for some European Countries. *Energy Economics*, **25**, pp. 137–154.
- Cunado J., and de Gracia F.P. (2005). Oil Prices, Economic Activity and Inflation: Evidence for Some Asian Countries. *Quarterly Review of Economics and Finance*, **45**, pp. 65–83.
- Dahlquist M., and Gray S. F. (2000). Regime-switching and Interest Rates in the European Monetary System. *Journal of International Economics*, **50**, pp. 399–419.
- Darby M. R. (1982). The Price of Oil and World Inflation and Recession. *American Economic Review*, **72**, pp. 738–751.
- Engel C. (1994). Can the Markov Switching Model Forecast Exchange Rates? *Journal of International Economics*, **36**, pp. 151–165.
- Engel C., and Hamilton J. D. (1990). Long Swings in the Dollar: Are They in the Data and do Markets Know It? *American Economic Review*, **80**, pp. 689–713.
- Feenstra R. C., and Hanson G. H. (1996). Globalization, Outsourcing, and Wage Inequality. *American Economic Review*, **86**(2), pp. 240–45.

- Ferderer J. P. (1996). Oil Price Volatility and the Macroeconomy. *Journal of Macroeconomics*, **18**, pp. 1–16.
- Filardo A. (1994). Business Cycle Phases and Their Transitional Dynamics. *Journal of Business and Economic Statistics*, **9**, pp. 299–308.
- Gisser M., and Goodwin T. H. (1986). Crude Oil and the Macroeconomy: Tests of Some Popular Notions. *Journal of Money, Credit and Banking*, **18**, pp. 95–103.
- Goodwin T. H. (1993). Business Cycle Analysis with a Markov-Switching Model. *Journal of Business and Economic Statistics*, **11**, pp. 331–339.
- Granger C. W. J., and Terasvirta T. (1993). *Modelling Nonlinear Economic Relationships*. Oxford: Oxford University Press.
- Gronwald M. (2006). *Oil Shocks and Real GDP Growth in Germany: Looking for a Needle in a Haystack*. Working Paper. University of Hamburg, Department of Economics.
- Hamilton J. D. (1983). Oil and the Macroeconomy since World War II. *Journal of Political Economy*, **91**, pp. 228–248.
- Hamilton J. D. (1988). Rational-Expectations Econometric Analysis of Changes in Regime: An Investigation of the Term Structure of Interest Rates. *Journal of Economic Dynamics and Control*, **12**, pp. 385–423.
- Hamilton J. D. (1989). A New Approach to the Economic Analysis of Nonstationary Time Series and the Business Cycle. *Econometrica*, **57**, pp. 357–384.
- Hamilton J. D. (1990). Analysis of Time Series Subject to Changes in Regime. *Journal of Econometrics*, **4**, pp. 39–70.
- Hamilton J. D. (1995). *Time Series Analysis*. Princeton, New Jersey (U.S.): Princeton University Press.
- Hamilton J. D. (1996). This is What Happened to the Oil Price-Macroeconomy relationship. *Journal of Monetary Economics*, **38**, pp. 215–220.
- Hamilton J. D. (2003). What Is an Oil Shock? *Journal of Econometrics*, **113**, pp. 363–398.
- Hamilton J. D., and Herrera A. M. (2004). Oil Shocks and Aggregate Macroeconomic Behavior: The Role of Monetary Policy: Comment. *Journal of Money, Credit and Banking*, **36**(2), pp. 265–286.
- Hamilton J. D., and Lin G. (1996). Stock Market Volatility and the Business Cycle. *Journal of Applied Econometrics*, **11**, pp. 573–593.

- Hansen B. E. (1992). The Likelihood Ratio test Under Non-Standard Conditions: Testing the Markov Switching Model of GNP. *Journal of Applied Econometrics*, **7**, pp. 61–82.
- Hansen B. E. (1996). Erratum: The likelihood Ratio test Under Non-Standard Conditions: Testing the Markov Switching model of GNP. *Journal of Applied Econometrics*, **11**, pp. 195–199.
- Hansen B. E. (1997). Inference in TAR Models. *Studies in Nonlinear Dynamics and Econometrics*, **2**, pp. 1–14.
- Holmes M. J., and Wang P. (2003). Oil and the Asymmetric Adjustment of U.K. Output: A Markov-Switching Approach. *International Review of Applied Economics*, **17**, pp. 181–192.
- Hooker M. A. (1996). What Happened to the Oil Price-Macroeconomy relationship? *Journal of Monetary Economics*, **38**, pp. 195–213.
- Hooker M. A. (2002). Are Oil Shocks Inflationary? Asymmetric and Nonlinear Specifications versus Changes in Regime. *Journal of Money, Credit and Banking*, **34**(2), pp. 540–561.
- Huntington M. G. (2005). The Economic Consequences of Higher Oil Prices. *Final Report, EMF SR 9, Stanford University*.
- IEA International Energy Agency. (2004). *Oil Crises & Climate Challenges. 30 Years of Energy Use in IEA Countries*. Technical Report.
- Jeanne O., and Masson P. (2000). Currency Crises, Sunspots and Markov-Switching Regimes. *Journal of International Economics*, **50**, pp. 327–350.
- Jimenez-Rodriguez R., and Sanchez M. (2005). Oil Price Shocks and Real GDP Growth: Empirical Evidence for some OECD Countries. *Applied Economics*, **37**, pp. 201–228.
- Kaufmann R. K. (1995). A Model of the World Oil Market for Project LINK - Integrating Economics, Geology and Politics. *Economic Modelling*, **12**(2), pp. 165–178.
- Kilian L. (2005). Exogenous Oil Supply Shocks: How Big Are They and How Much Do They Matter for the U.S. Economy? *mimeo, Department of Economics, University of Michigan*.
- Kilian L. (2006). The Effects of Exogenous Oil Supply Shocks on Output and Inflation: Evidence from the G7 Countries. *Centre for Economic Policy Research*. Discussion Paper No. 5404.
- Kim C.-J., and Nelson C. R. (1999). Has The U.S. Economy Become More Stable? A Bayesian Approach Based On A Markov-Switching Model Of The Business Cycle. *The Review of Economics and Statistics*, **81**(4), pp. 608–616.



- Krolzig H. M. (1996). Statistical Analysis of Cointegrated VAR Processes with Markovian Regime Shifts. *Humboldt Universitaet. Sonderforschungsbereich 373* 1996-25.
- Krolzig H. M. (1997). *Markov Switching Vector Autoregressions. Modelling, Statistical Inference and Application to Business Cycle Analysis*. Berlin: Springer.
- Krolzig H. M., and Toro J. (2000). A New Approach to the Analysis fo Business Cycle Transitions in a Model of Output and Employment. *Department of Economics, University of Oxford*. Discussion Papers No. 59.
- Krolzig H. M., Marcellino M., and Mizon G. (2002). A Markov-Switching Vector Equilibrium Correction model of the U.K. Labour Market. *Empirical Economics*, **27**, pp. 233–254.
- Lee B. R., Lee K., and Ratti R. A. (2001). Monetary Policy, Oil Price Shocks, and the Japanese Economy. *Japan and the World Economy*, **13**(3), pp. 321–349.
- Lee K., Ni S., and Ratti R. A. (1995). Oil Shocks and the Macroeconomy: the Role of Price Volatility. *Energy Journal*, **16**, pp. 39–56.
- Mabro R. (1998). OPEC Behavior 1960-1998: A Review of the Literature. *Journal of Energy Literature*, **4**(1), pp. 3–27.
- Marcellino M., Stock J. H., and Watson M. W. (2003). Macroeconomic Forecasting in the Euro Area: Country Specific Versus Area-Wide Information. *European Economic Review*, **47**(1), pp. 1–18.
- Montgomery A. L., Zarnowitz V., Tsay R. S., and Tiao G. C. (1998). Forecasting the U.S. Unemployment Rate. *Journal of the American Statistical Association*, **93**, pp. 478–493.
- Mork K. A. (1989). Oil Shocks and the Macroeconomy when Prices Go Up and Down: an Extension of Hamilton’s Results. *Journal of Political Economy*, **97**, pp. 740–744.
- Mork K. A., Olsen O., and Mysen H. T. (1994). Macroeconomic Responses to Oil Price Increases and Decreases in Seven OECD Countries. *Energy Journal*, **15**, pp. 19–35.
- Motonishi T., and Yoshikawa H. (1999). Causes of the Long Stagnation of Japan during the 1990s: Financial or Real? *Journal of the Japanese and International Economies*, **13**(3), pp. 181–200.
- Nordhaus W. (2007). *Who’s Afraid of a Big Bad Oil Shock*. Preliminary draft prepared for Brookings panel on Economic Activity.
- Pindyck R. S., and Rotemberg J. J. (1983). Dynamic Factor Demands and the Effects of Energy Price Shocks. *American Economic Review*, **73**, pp. 1066–1079.

- Potter S. M. (1995). A Nonlinear Approach to U.S. GNP. *Journal of Applied Econometrics*, **10**(2), 109–25.
- Psaradakis Z., and Spagnolo N. (2003). On the Determination of the Number Of Regimes in Markov-Switching Autoregressive Models. *Journal of Time Series Analysis*, **24**, pp. 237–252.
- Raymond J. E., and Rich R. W. (1997). Oil and the Macroeconomy: A Markov State-Switching Approach. *Journal of Money, Credit and Banking*, **29**, pp. 193–213.
- Romer C. D. (1999). Changes in Business Cycles: Evidence and Explanations. *Journal of Economic Perspectives*, **13**(2), pp. 23–44.
- Romer C. D., and Romer D. H. (1989). Does Monetary Policy Matter? A New Test in the Spirit of Friedman and Schwartz. *NBER Macroeconomic Annual*, **4**, pp. 121–170.
- Romer C. D., and Romer D. H. (1994). Monetary Policy Matters. *Journal of Monetary Economics*, **34**(1), pp. 75–88.
- Sadorsky P. (1999). Oil Price Shocks and Stock Market Activity. *Energy Economics*, **21**(5), pp. 449–469.
- Sensier M., Artis M., Osborn D. R., and Birchenhall C. (2004). Domestic and International Influences on Business Cycle Regimes in Europe. *International Journal of Forecasting*, **20**(2), pp. 343–357.
- Sichel D. E. (1994). Inventories and the Three Phases of the Business Cycle. *Journal of Business and Economic Statistics*, **12**, pp. 269–277.
- Stanca L. (1999). Asymmetries and Nonlinearities in Italian Macroeconomic Fluctuations. *Applied Economics*, **31**, pp. 483–491.
- Stock J. H., and Watson M. W. (2002). *Has the Business Cycle Changed and Why?* NBER Working Papers 9127. National Bureau of Economic Research, Inc.
- Stock J. H., and Watson M. W. (2003). How Did Leading Indicator Forecasts Perform during the 2001 Recession? *Economic Quarterly*, **Sum**, pp. 71–90.
- Tatom J. (1988). Are the Macroeconomic Effects of Oil Price Changes Symmetric? *Carnegie - Rochester Conference Series on Public Policy*, **28**, pp. 325–368.
- Taylor M. P., Peel D. A., and Sarno L. (2001). Nonlinear Mean-Reversion in Real Exchange Rates: Toward a Solution to the Purchasing Power Parity Puzzles. *International Economic Review*, **42**, pp. 1015–1042.
- Terasvirta T. (1994). Specification, Estimation, and Evaluation of Smooth Transition Autoregressive Models. *Journal of the American Statistical Association*, **89**, pp. 208–218.

Terasvirta T., and Anderson H. M. (1992). Characterizing Nonlinearities in Business Cycles Using Smooth Transition Autoregressive Models. *Journal of Applied Econometrics*, **7**(S), pp. S119–136.

The Economist. (2007). Shock Treatment. *Economic Focus*, November 21th.

van Dijk D., Terasvirta T., and Franses P.H. (2000). *Smooth Transition Autoregressive Models - A Survey of Recent Developments*. Econometric Institute Report 200. Erasmus University Rotterdam, Econometric Institute.

Table 1: Business cycles for the G-7 Countries

	Canada	France	Germany	Italy	Japan	United Kingdom	United States
				10/1970			
1970-1975				<i>08/1971</i>			
		07/1974	08/1973	04/1974	11/1973	09/1974	11/1973
		<i>06/1975</i>	<i>07/1975</i>	<i>04/1975</i>	<i>02/1975</i>	<i>08/1975</i>	<i>03/1975</i>
1976-1980		08/1979	01/1980	05/1980		06/1979	01/1980
		<i>06/1980</i>		<i>05/1983</i>		<i>05/1981</i>	<i>07/1980</i>
1981-1985	04/1981	04/1982					07/1981
	<i>11/1982</i>	<i>12/1984</i>	<i>10/1982</i>				<i>11/1982</i>
1986-1990	03/1990					05/1990	07/1990
1991-1995		02/1992	01/1991	02/1992	04/1992		
	<i>03/1992</i>	<i>08/1993</i>	<i>04/1994</i>	<i>10/1993</i>	<i>02/1994</i>	<i>03/1992</i>	<i>03/1991</i>
					03/1997		
1996-2000					<i>07/1999</i>		
					08/2000		
2001-2005			01/2001				03/2001
			<i>08/2003</i>		<i>04/2003</i>		<i>11/2001</i>

*Notes.* Entries of this table are the business cycle peak and trough dates (month/year) as indicated by the Economic Cycle Research Institute (ECRI) in September 2005, with the exception of United States, where the source of information is the National Bureau of Economic Research (NBER).

Table 2: Selected Markov switching models with exogenous oil prices

	Canada		France		Germany	
	MSM(3)-ARX(4)		MSMH(3)-ARX(1)		MSIAH(3)-ARX(4)	
log-likelihood	499.63	525.26	469.80			
AIC	-7.14	-7.64	-6.53			
LR linearity test	$\chi^2(2)=54.65 [0.0000]$ ***	$\chi^2(4)=25.27 [0.0000]$ ***	$\chi^2(22)=65.90 [0.0000]$ ***			
	coefficient	standard error	coefficient	standard error	coefficient	standard error
mean (regime 1)	-0.003	0.002	0.001	**	0.004	0.002 *
mean (regime 2)	0.011	0.002	0.010	0.001	0.001	0.001
mean (regime 3)	0.020	0.002	0.013	0.001	0.001	0.001
constant (regime 1)						
constant (regime 2)						
constant (regime 3)						
$\Delta$ gdp(t-1)	0.448	0.065	-0.153	0.070	0.148	0.028 ***
$\Delta$ gdp(t-2)	-0.217	0.074			-0.055	0.028 **
$\Delta$ gdp(t-3)	0.497	0.076			-0.030	0.029 ***
$\Delta$ gdp(t-4)	-0.212	0.061			0.232	0.029 ***
$\Delta$ gdp(t-5)						
$\Delta$ gdp(t-6)						
oil(t-1)	0.005	0.005	-0.0004	0.0013	-0.004	0.002 **
oil(t-2)	-0.014	0.005	-0.001	0.0005	0.0003	0.002 ***
oil(t-3)	0.001	0.005	-0.0003	0.0004	-0.011	0.002 ***
oil(t-4)	-0.012	0.005	-0.002	0.0004	0.006	0.002 ***
dummy					0.082	0.003 ***
Standard error		0.005				
Standard error (reg.1)		0.003				
Standard error (reg.2)		0.002				
Standard error (reg.3)		0.004				
regime properties	Prob.	Duration	Prob.	Duration	Prob.	Duration
regime 1	0.61	0.01	0.39	0.65	0.35	0.00
regime 2	0.02	0.96	0.01	0.20	0.68	0.13
regime 3	0.21	0.36	0.42	0.11	0.00	0.89
regime 1	0.88	0.08	0.04			
regime 2	0.00	0.93	0.07			
regime 3	0.17	0.08	0.75			
regime 1	0.001	0.035	0.001	0.035	0.001	0.035
regime 2	-0.005	0.061	-0.005	0.061	-0.005	0.061
regime 3	-0.010	0.048	-0.010	0.048	-0.008	0.005 *
regime 1	0.017	0.002	0.017	0.002	0.017	0.002
regime 2	-0.266	0.074	-0.266	0.074	-0.266	0.074
regime 3	0.159	0.065	0.159	0.065	0.159	0.065
regime 1	0.225	0.061	0.225	0.061	0.225	0.061
regime 2	-0.126	0.055	-0.126	0.055	-0.126	0.055
regime 3	0.083	0.005	0.083	0.005	0.083	0.005
Standard error (reg.1)		0.009				
Standard error (reg.2)		0.009				
Standard error (reg.3)		0.003				

Notes. For Germany, Japan and U.S. the exogenous oil prices (oil) refer to net oil price increases (NOP); for Italy, France and United Kingdom the model includes oil price volatility (oil\_vol); for Canada the specification of oil prices is represented by oil price increases; for Germany a dummy is considered for the 1991q1; for Japan a dummy is considered for 1974q1; AIC = Akaike Information Criterion; the LR linearity test is distributed as a chi-square with d degrees of freedom, i.e.  $\chi^2(d)$ ; p-values are reported in square brackets. \*\*\* (\*\*, \*) denotes significance of the coefficient (rejection of the null hypothesis in the case of linearity test) at the 1% (5%, 10%) level.

Table 2 (ctd): Selected Markov switching models with exogenous oil prices (continued)

	model Italy MSIAH(3)-ARX(3)		model Japan MSMH(3)-ARX(1)		model United Kingdom MSMH(3)-ARX(3)		model United States MSMH(3)-ARX(4)	
log-likelihood	507.37		450.35		414.10		482.27	
AIC	-7.13		-6.41		-5.94		-7.00	
LR linearity test	$\chi^2(18)=65.17 [0.0000]^{***}$		$\chi^2(4)=43.71 [0.0000]^{***}$		$\chi^2(4)=49.48 [0.0000]^{***}$		$\chi^2(4)=45.06 [0.0000]^{***}$	
	coefficient	standard error	coefficient	standard error	coefficient	standard error	coefficient	standard error
mean (regime 1)			-0.008	0.001	0.002	0.002	-0.001	0.002
mean (regime 2)			0.007	0.001	0.010	0.001	0.009	0.001
mean (regime 3)			0.015	0.003	0.017	0.002	0.018	0.002
constant (regime 1)	-0.003	0.001						
constant (regime 2)								
constant (regime 3)								
$\Delta gdp(t-1)$	0.460	0.065	0.017	0.002				
$\Delta gdp(t-2)$	-0.047	0.091	0.500	0.090	-0.540	0.094	-0.123	0.093
$\Delta gdp(t-3)$	-0.054	0.105	-0.353	0.106	-0.426	0.103	0.118	0.062
$\Delta gdp(t-4)$			0.355	0.087	-0.399	0.086	-0.159	0.069
$\Delta gdp(t-5)$							-0.365	0.086
$\Delta gdp(t-6)$								
oil(t-1)	0.0003	0.0002	-0.0029	0.0007	-0.0052	0.004	-0.017	0.005
oil(t-2)	0.0007	0.0001	0.0011	0.0011	0.0003	0.005	-0.002	0.004
oil(t-3)	-0.0001	0.0001	0.0036	0.0013	-0.0018	0.003	-0.002	0.004
oil(t-4)	-0.0013	0.0001	-0.0073	0.0012	-0.0038	0.002	-0.009	0.004
dummy			-0.0704	0.006				
Standard error								
Standard error (reg.1)		0.001						
Standard error (reg.2)								
Standard error (reg.3)								
	regime 1	regime 2	regime 3	regime 1	regime 2	regime 3	regime 1	regime 2
regime 1	0.55	0.26	0.19	0.48	0.52	0.00	0.85	0.02
regime 2	0.02	0.96	0.02	0.07	0.89	0.04	0.00	1.00
regime 3	0.26	0.00	0.73	0.00	0.13	0.87	0.16	0.00
regime properties	Prob.	Duration	Prob.	Duration	Prob.	Duration	Prob.	Duration
regime 1	0.11	2.21	0.09	1.91	0.00	6.60	0.17	3.42
regime 2	0.76	25.64	0.67	9.03	1.00	na	0.62	8.58
regime 3	0.13	3.76	0.24	7.97	0.00	6.34	0.20	2.79

Figure 1: Selected Markov switching model for the G-7 Countries.

a) Canada - MSM(3)-ARX(4)

a1) Smoothed and filtered probabilities

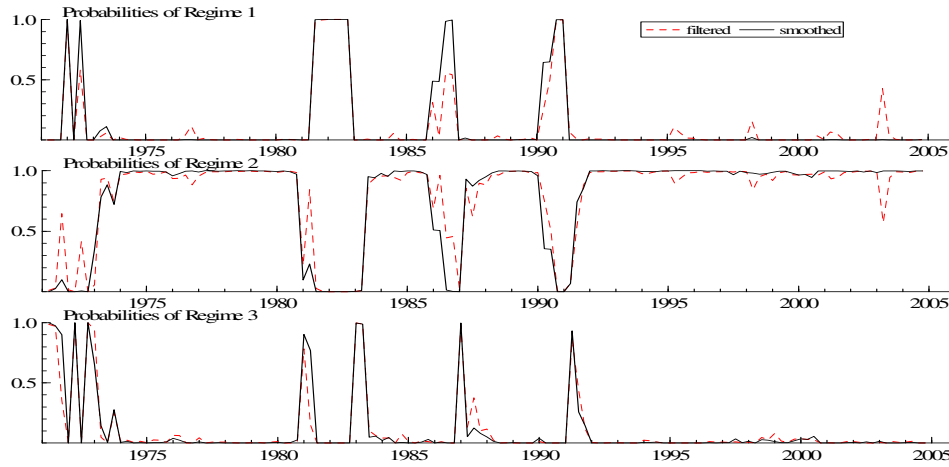

a2) Actual, fitted and standardized residuals

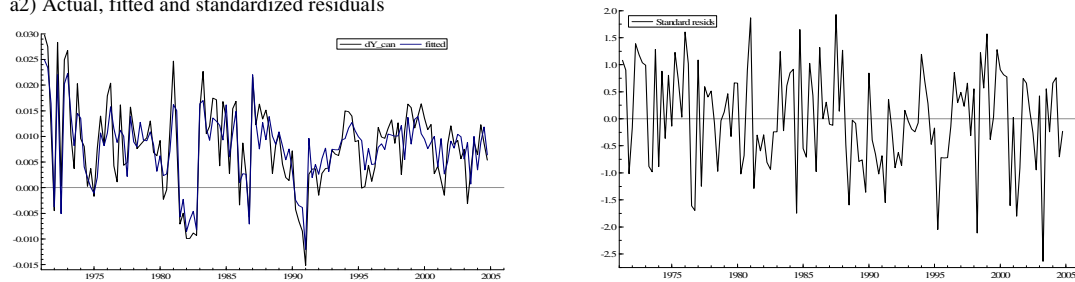

b) France - MSMH(3)-ARX(1)

b1) Smoothed and filtered probabilities

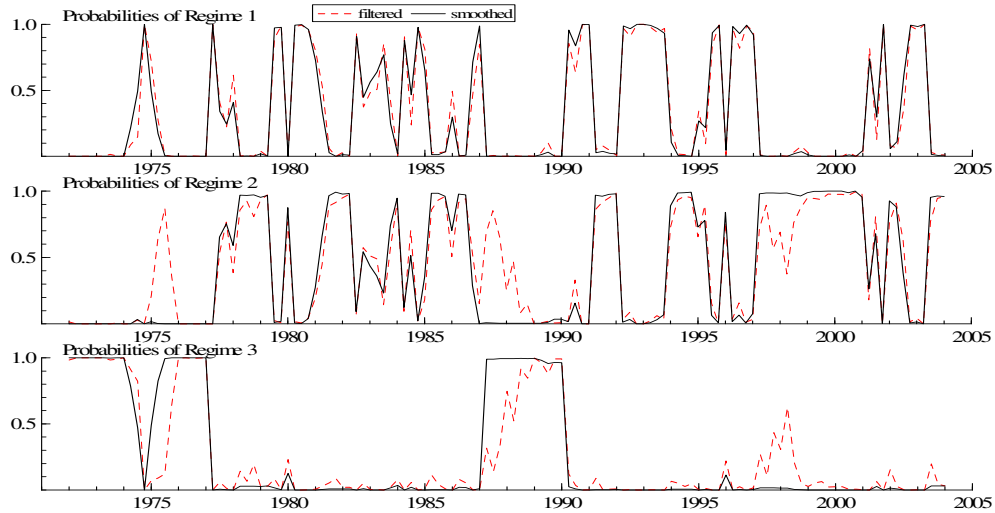

b2) Actual, fitted and standardized residuals

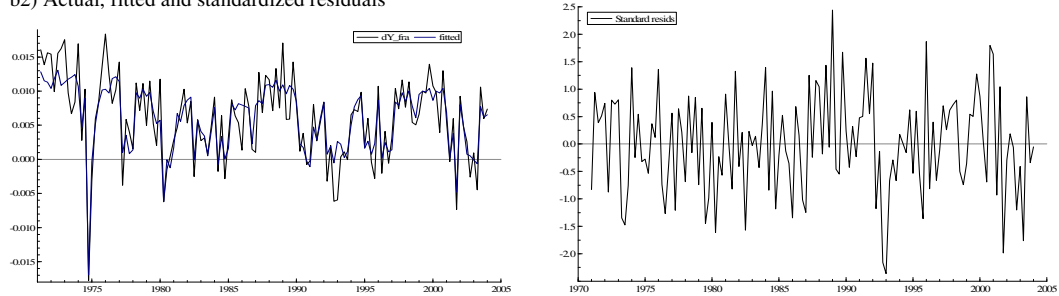
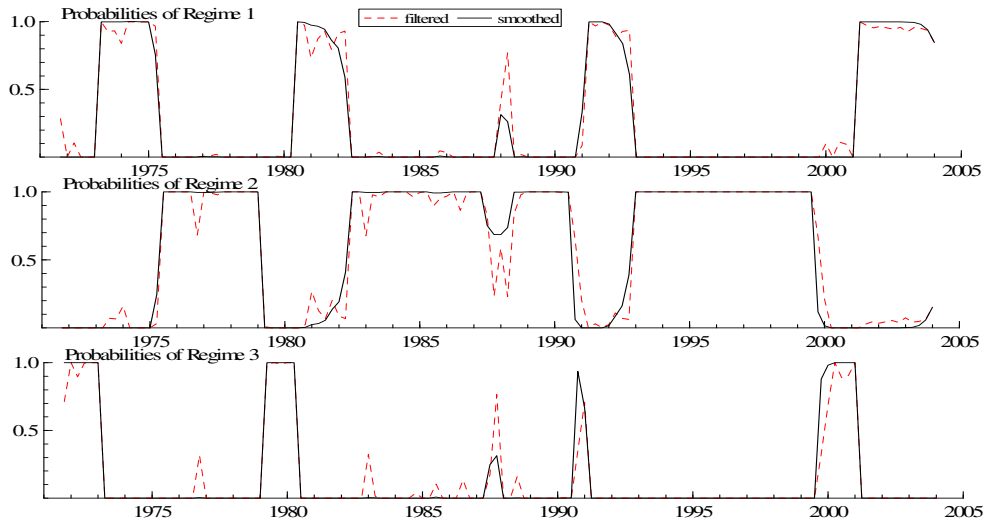

Figure 1 (ctd): Selected Markov switching model for the G-7 Countries.

c) Germany - MSIAH(3)-ARX(4)

c1) Smoothed and filtered probabilities



c2) Actual, fitted and standardized residuals

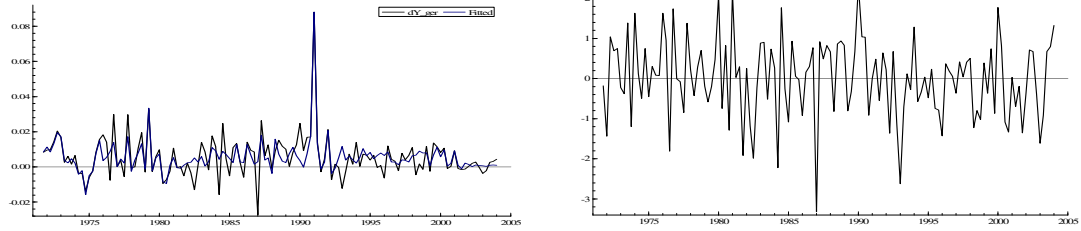

d) Italy - MSIAH(3)-ARX(3)

d1) Smoothed and filtered probabilities

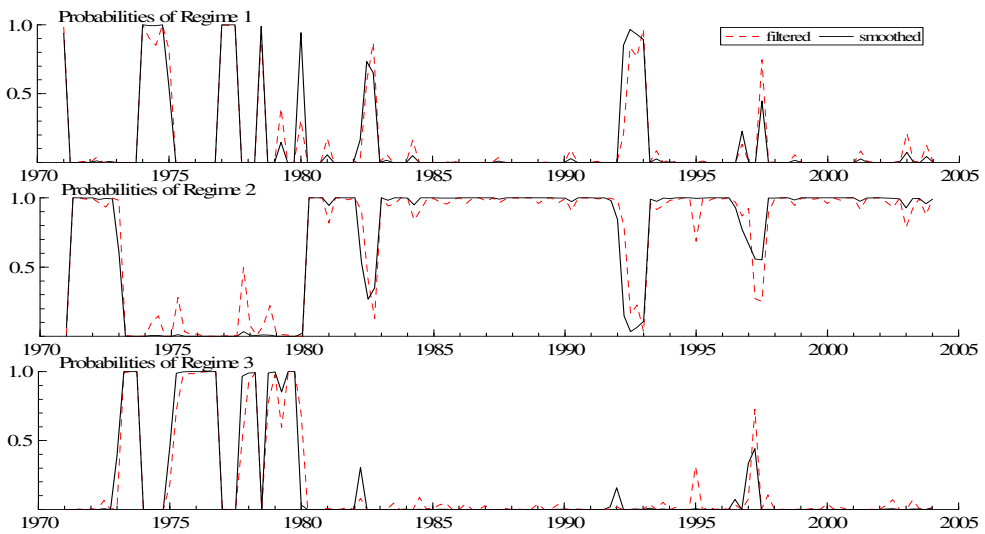

d2) Actual, fitted and standardized residuals

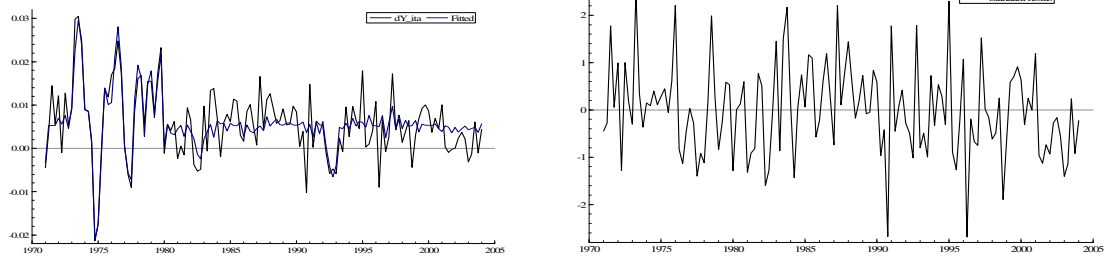
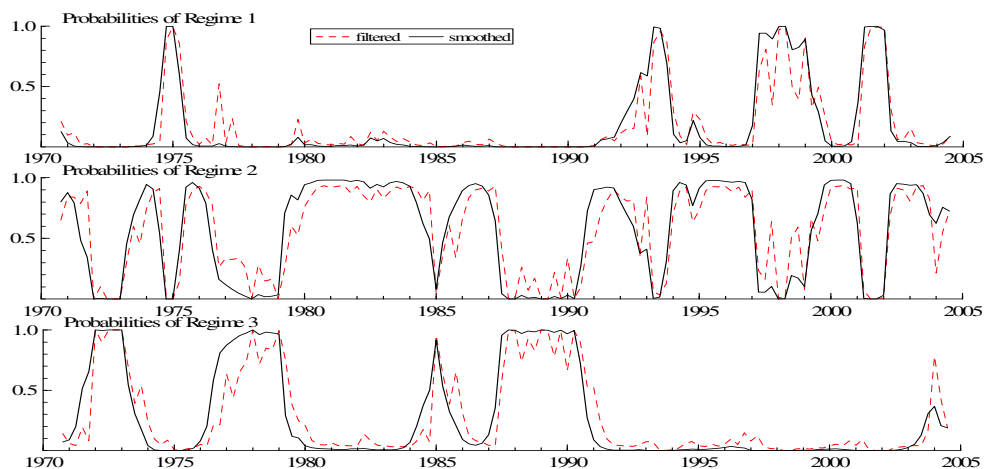



Figure 1 (ctd): Selected Markov switching model for the G-7 Countries.

e) Japan - MSMH(3)-ARX(1)

e1) Smoothed and filtered probabilities



e2) Actual, fitted and standardized residuals

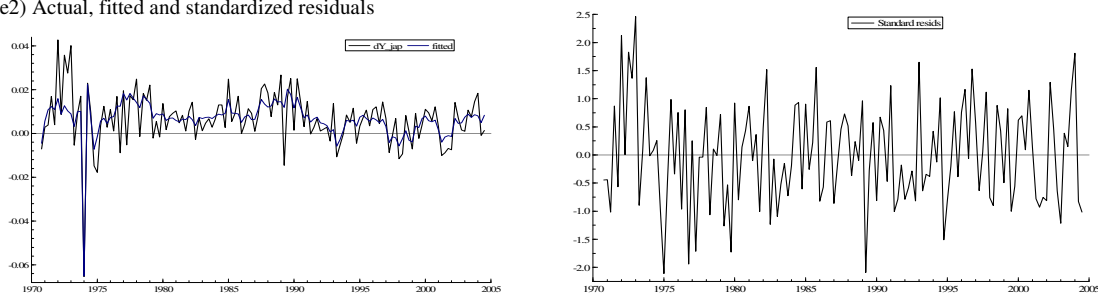

f) United Kingdom - MSMH(3)-ARX(4)

f1) Smoothed and filtered probabilities

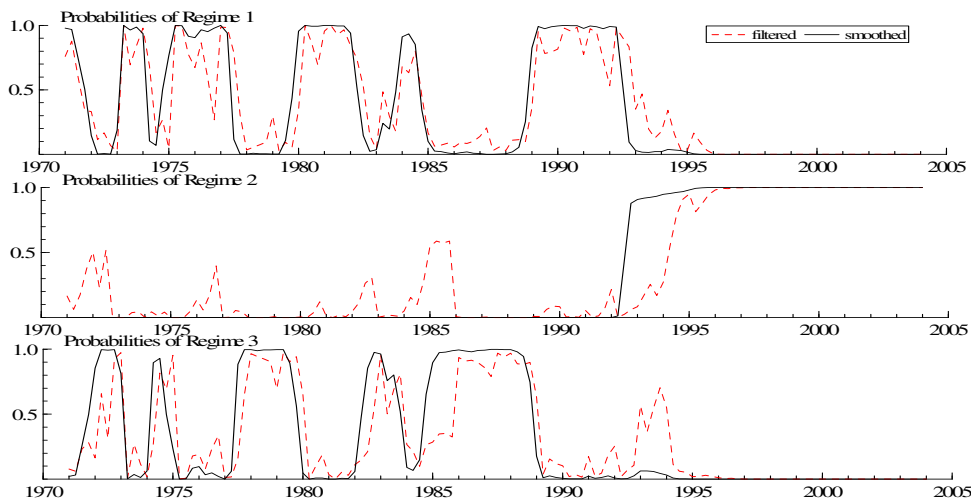

f2) Actual, fitted and standardized residuals

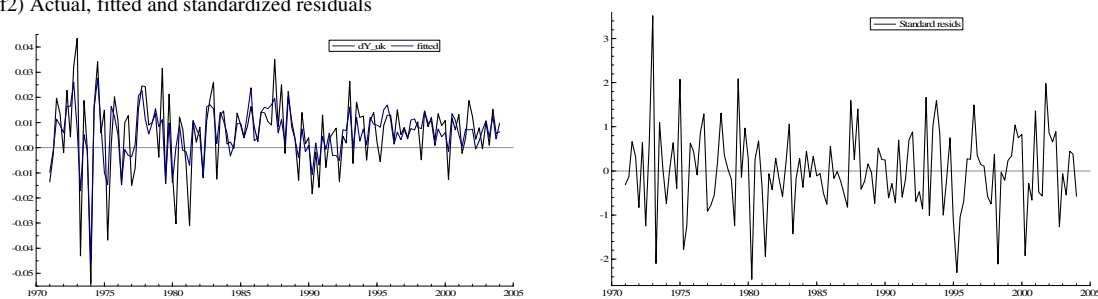
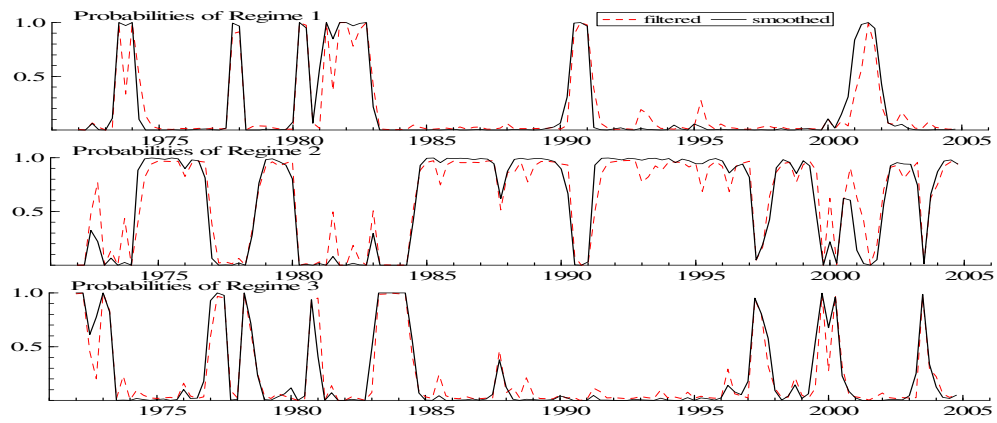

Figure 1 (ctd): Selected Markov switching model for the G-7 Countries.

g) United States - MSMH(3)-ARX(4)

g1) Smoothed and filtered probabilities



g2) Actual, fitted and standardized residuals

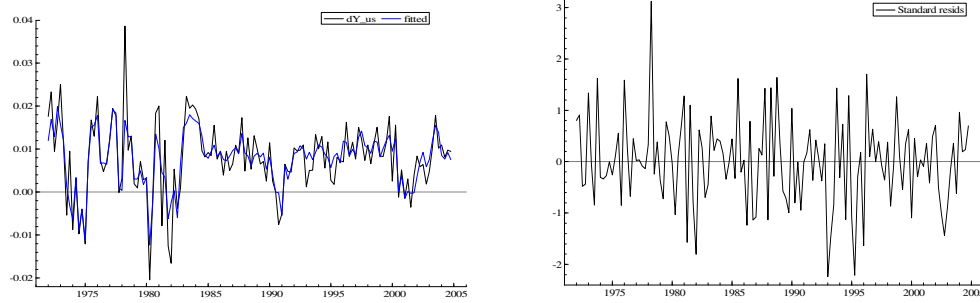

Table 3: Likelihood Ratio tests for the significance of oil across different subsamples. Recursive estimates.

	Full Sample (1970q1, 2005q1)		Sub-Sample 1980q1, 2005q1		Structural break point	
	LR Test	$\chi^2(d)$ Prob.	LR Test	$\chi^2(d)$ Prob.	LR Test	$\chi^2(d)$ Prob.
Canada	$\chi^2(4)=13.251$	0.010***	$\chi^2(4)=4.877$	0.300	1974q4, 2005q1	$\chi^2(4)=7.451$ 0.114
France	$\chi^2(4)=31.324$	0.000***	$\chi^2(4)=16.983$	0.002***	1987q2, 2005q1	$\chi^2(4)=8.393$ 0.078*
Germany	$\chi^2(12)=39.287$	0.000***	$\chi^2(12)=55.698$	0.000***	1975q1, 2005q1	$\chi^2(12)=17.117$ 0.145
Italy	$\chi^2(12)=27.134$	0.007***	$\chi^2(12)=10.220$	0.597	1975q1, 2005q1	$\chi^2(12)=18.763$ 0.094*
Japan	$\chi^2(4)=9.183$	0.057*	$\chi^2(4)=1.770$	0.778	1973q2, 2005q1	$\chi^2(4)=0.781$ 0.941
United Kingdom	$\chi^2(4)=14.181$	0.007***	$\chi^2(4)=4.575$	0.334	1974q4, 2005q1	$\chi^2(4)=2.625$ 0.622
United States	$\chi^2(4)=9.172$	0.057*	$\chi^2(4)=10.020$	0.040**	1976q3, 2005q1	$\chi^2(4)=3.824$ 0.430

Notes: the LR test is distributed as a chi-square with d degrees of freedom, i.e.  $\chi^2(d)$ ; \*\*\* (\*\*, \*) denotes rejection of the null hypothesis at the 1% (5%, 10%) level. "Structural break point" denotes the first sample according to which there seems to be a diminishing role of oil shock in explaining business cycle features.

Table 4: Test for structural breaks with unknown changing point

	Test of differential intercepts			Test of differential slope coefficients			Test of differential intercepts and slope coefficients			Test of differential slope coefficients (only oil)		
	LR Test	$\chi^2(d)$ Prob.	Date of the Break	LR Test	$\chi^2(d)$ Prob.	Date of the Break	LR Test	$\chi^2(d)$ Prob.	Date of the Break	LR Test	$\chi^2(d)$ Prob.	Date of the Break
Canada	$\chi^2(1)=8.116$	0.004***	1973q2	$\chi^2(8)=34.691$	0.000***	1981q3	$\chi^2(9)=37.720$	0.000***	1981q3	$\chi^2(4)=21.254$	0.000***	1972q2
France	$\chi^2(1)=14.635$	0.000***	1974q2	$\chi^2(5)=52.415$	0.000***	1975q4	$\chi^2(6)=53.705$	0.000***	1975q4	$\chi^2(4)=24.742$	0.000***	1977q1
Germany	$\chi^2(3)=24.809$	0.000***	1978q3	$\chi^2(24)=229.650$	0.000***	1978q3	$\chi^2(27)=254.458$	0.000***	1978q3	$\chi^2(12)=143.666$	0.000***	1972q1
Italy	$\chi^2(3)=65.578$	0.000***	1984q1	$\chi^2(21)=145.473$	0.000***	1977q3	$\chi^2(24)=159.825$	0.000***	1977q3	$\chi^2(12)=123.196$	0.000***	1983q1
Japan	$\chi^2(1)=11.655$	0.001***	1973q1	$\chi^2(5)=21.204$	0.001***	2002q1	$\chi^2(6)=20.754$	0.002***	1974q2	$\chi^2(4)=22.242$	0.000***	1979q3
United Kingdom	$\chi^2(1)=16.431$	0.000***	1982q4	$\chi^2(7)=36.014$	0.000***	1972q2	$\chi^2(8)=43.459$	0.000***	1972q2	$\chi^2(4)=31.920$	0.000***	1991q3
United States	$\chi^2(1)=14.732$	0.000***	2001q1	$\chi^2(8)=30.628$	0.000***	1972q3	$\chi^2(9)=41.445$	0.000***	1973q4	$\chi^2(4)=21.240$	0.000***	1995q2

See notes to Table 3.

Figure 2: Structural Break analysis of MS-ARX models. Recursive estimates.

a) Canada

a1) Fixed starting observation, variable ending observation

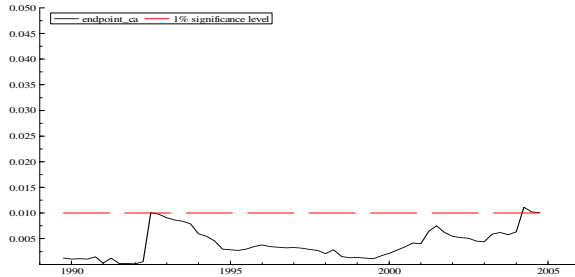

a2) Variable starting observation, fixed ending observation

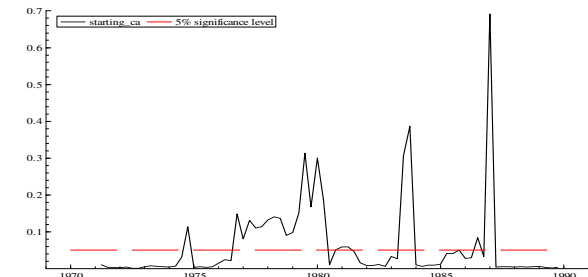

b) France

b1) Fixed starting observation, variable ending observation

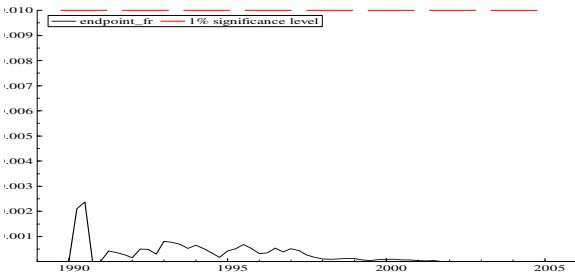

b2) Variable starting observation, fixed ending observation

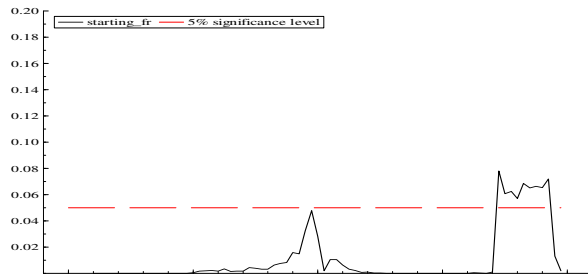

c) Germany

c1) Fixed starting observation, variable ending observation

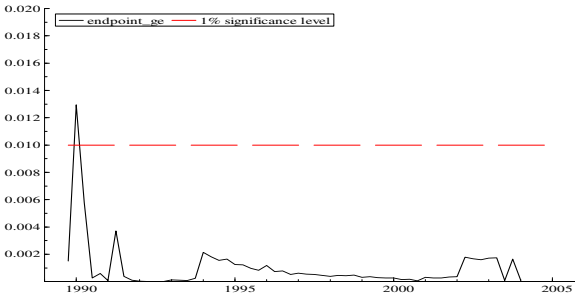

c2) Variable starting observation, fixed ending observation

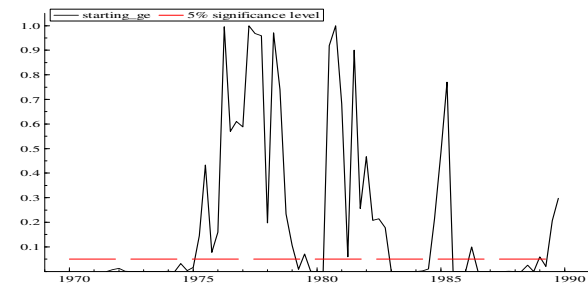

d) Italy

d1) Fixed starting observation, variable ending observation

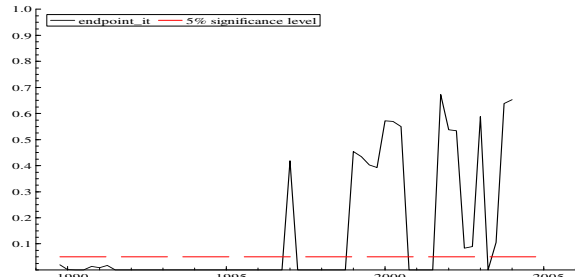

d2) Variable starting observation, fixed ending observation

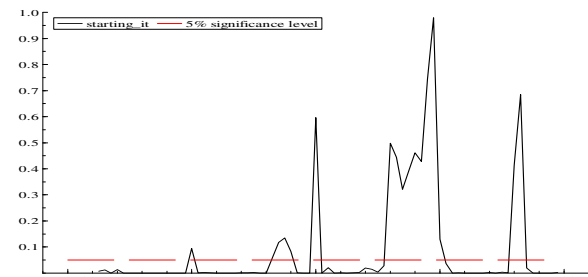
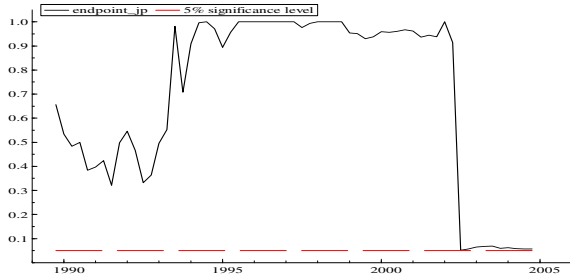

Figure 2 (ctd): Structural Break analysis of MS-ARX models. Recursive estimates.

e) Japan

e1) Fixed starting observation, variable ending observation



e2) Variable starting observation, fixed ending observation

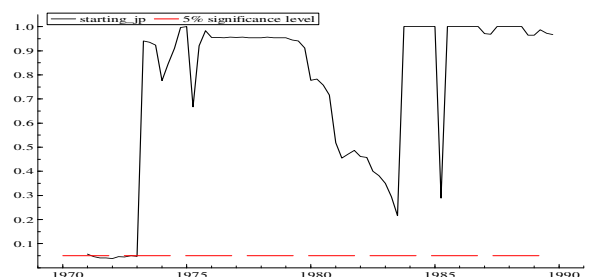

f) United Kingdom

f1) Fixed starting observation, variable ending observation

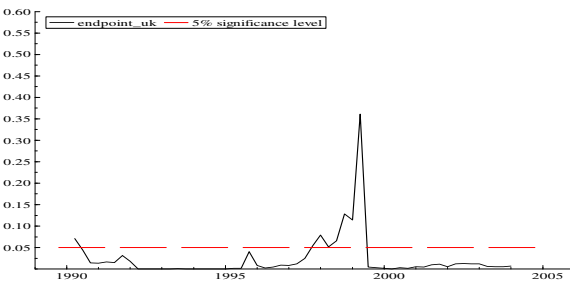

f2) Variable starting observation, fixed ending observation

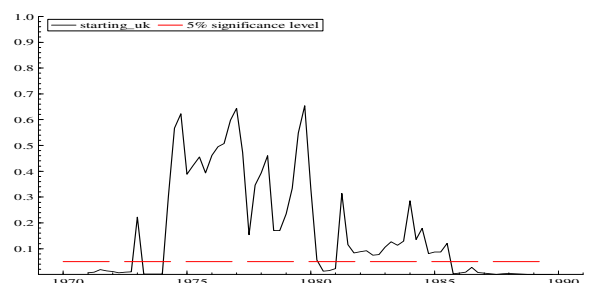

g) United States

g1) Fixed starting observation, variable ending observation

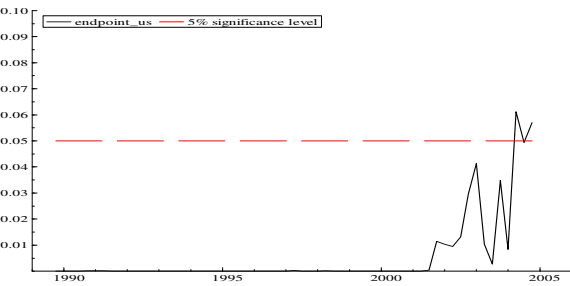

g2) Variable starting observation, fixed ending observation

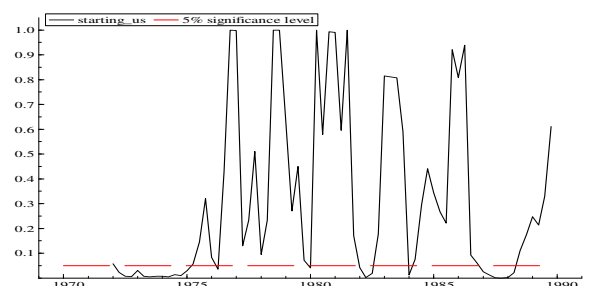

Table 5: Selected Markov switching VAR models

	G-7 Countries			United States		
	MSM(3)-VAR(5)			MSM(3)-VAR(1)		
log-likelihood	670.781			639.891		
AIC	-9.489			-8.998		
LR linearity test	$\chi^2(4)=89.4306 [0.0000]$			$\chi^2(4)=105.029 [0.0000]$		
Equation	$\Delta$ gdp	oil	oil	$\Delta$ gdp	oil	oil
	coefficient	standard error	coefficient	standard error	coefficient	standard error
mean (regime 1)	0.012	0.004	***	0.020	0.013	0.026 *
mean (regime 2)	0.011	0.005	**	0.171	0.023	0.011 ***
mean (regime 3)	0.011	0.005	**	0.456	0.028	0.033 ***
constant (regime 1)						
constant (regime 2)						
constant (regime 3)						
$\Delta$ gdp(t-1)	0.511	0.086	***	-0.345	0.838	0.720
$\Delta$ gdp(t-2)	-0.013	0.098		-0.130	0.976	
$\Delta$ gdp(t-3)	0.232	0.094	**	-0.966	0.901	
$\Delta$ gdp(t-4)	-0.018	0.096		0.247	0.946	
$\Delta$ gdp(t-5)	-0.010	0.083		1.174	0.838	
$\Delta$ gdp(t-6)						
oil(t-1)	-0.006	0.005		0.047	0.054	0.060 **
oil(t-2)	-0.023	0.005	***	0.116	0.054	
oil(t-3)	-0.014	0.005	***	0.050	0.052	
oil(t-4)	-0.011	0.005	**	0.036	0.050	
oil(t-5)	0.004	0.005		-0.166	0.047	
oil(t-6)						
dummy						
Standard error (reg.1)	0.0055			0.0068		
Standard error (reg.2)				0.068		
Standard error (reg.3)				0.068		
regime 1	regime 1	regime 2	regime 3	regime 1	regime 2	regime 3
regime 2	0.92	0.04	0.03	0.60	0.40	0.00
regime 3	0.71	0.29	0.00	0.01	0.96	0.03
regime 1	0.18	0.49	0.33	0.65	0.00	0.35
regime properties	Prob.			Duration		
regime 1	0.87	13.27		0.08	2.49	
regime 2	0.08	1.42		0.88	26.62	
regime 3	0.04	1.50		0.03	1.53	

Notes . For both the US and the aggregate variable for the G-7 countries the specification of oil prices is represented by oil price increases; AIC = Akaike Information Criterion; the LR linearity test is distributed as a chi-square with d degrees of freedom, i.e.  $\chi^2(d)$ ; p-values are reported in square brackets. \*\*\* (\*\*, \*) denotes significance of the coefficient (rejection of the null hypothesis in the case of linearity test) at the 1% (5%, 10%) level.

Figure 3: Selected Markov switching model VAR model for real GDP G-7 countries (aggregate measure) - MSM(3)-VAR(5)

a) Smoothed and filtered probabilities

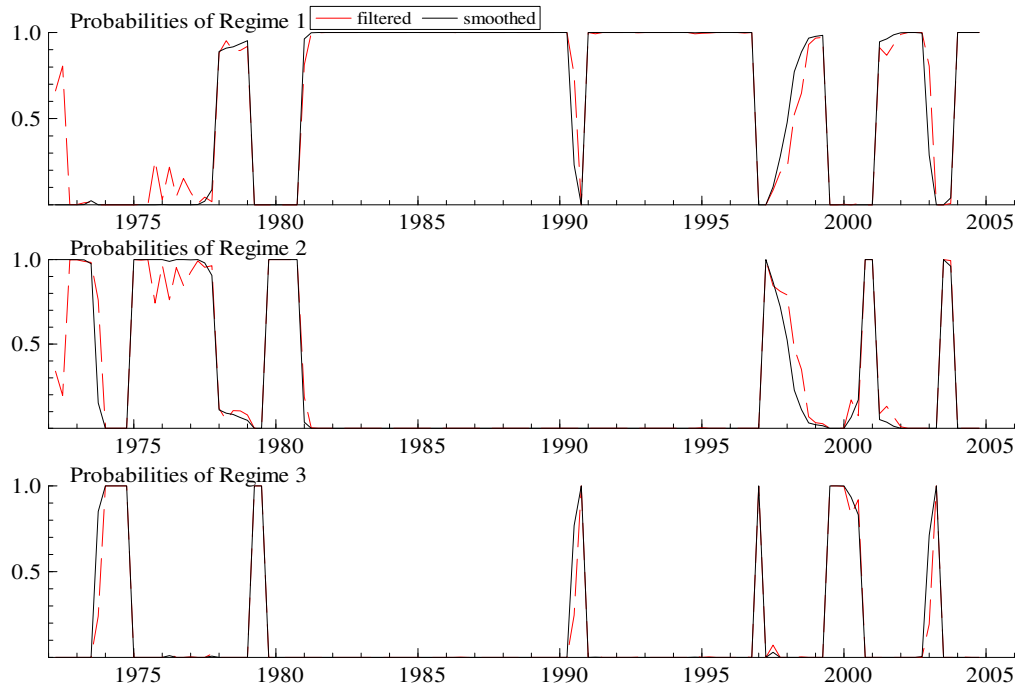

b) Actual, fitted and standardized residuals

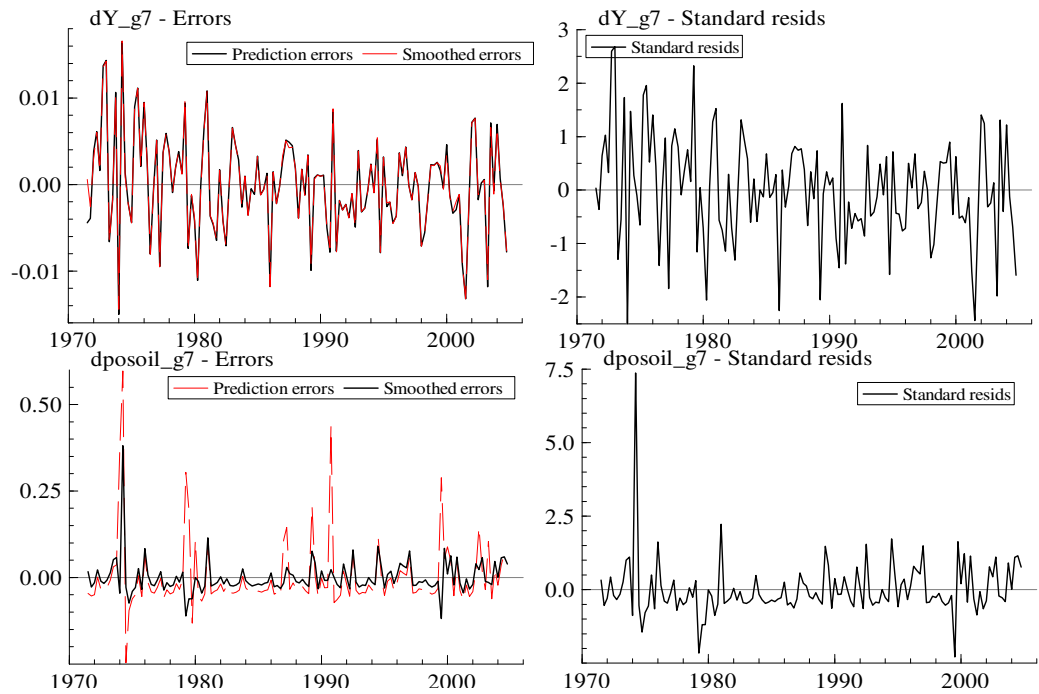

Figure 4: Selected Markov switching model VAR model for United States - MSM(3)-VAR(1)  
a) Smoothed and filtered probabilities

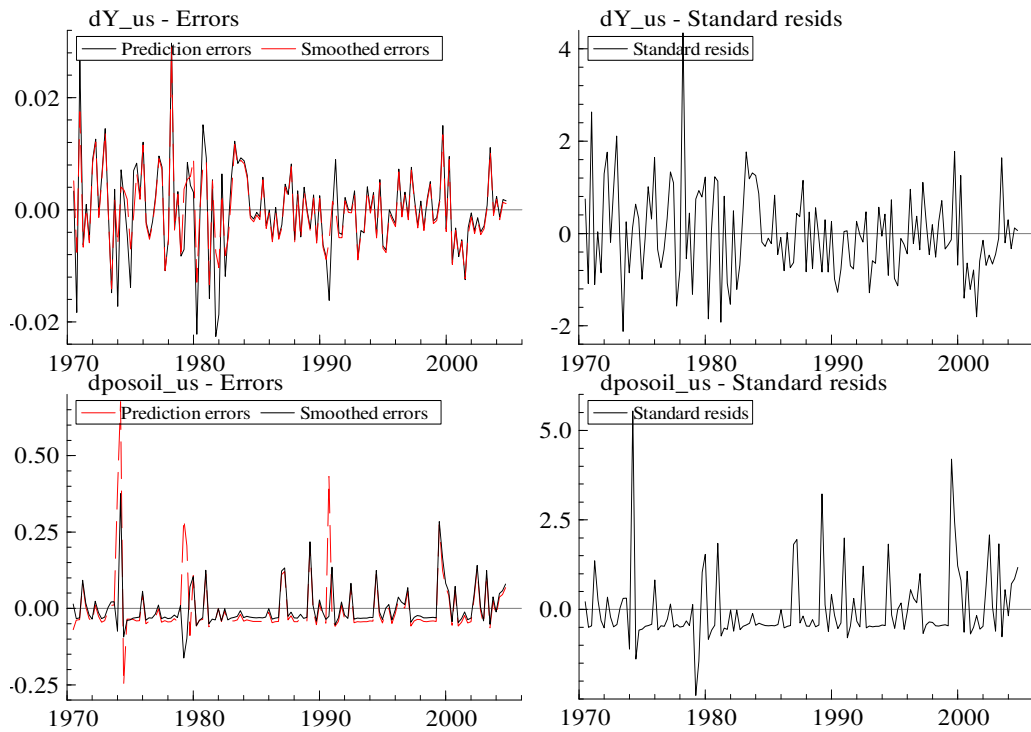
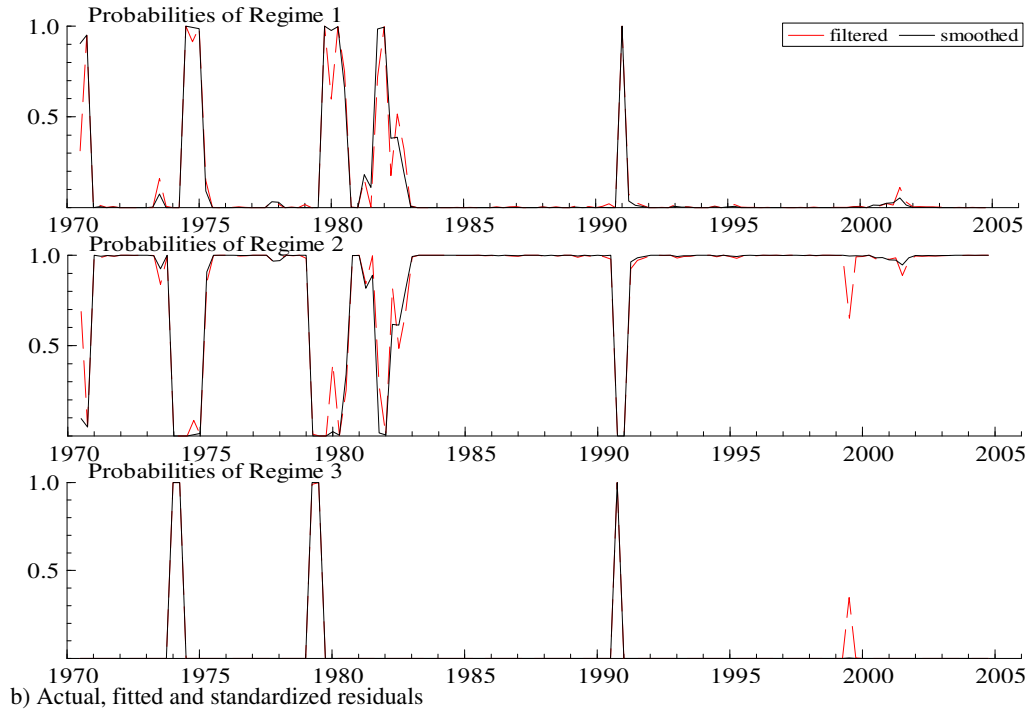
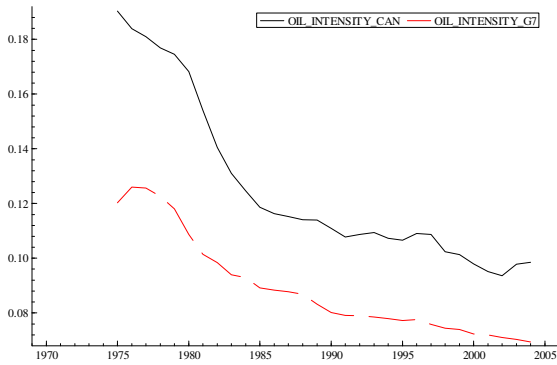

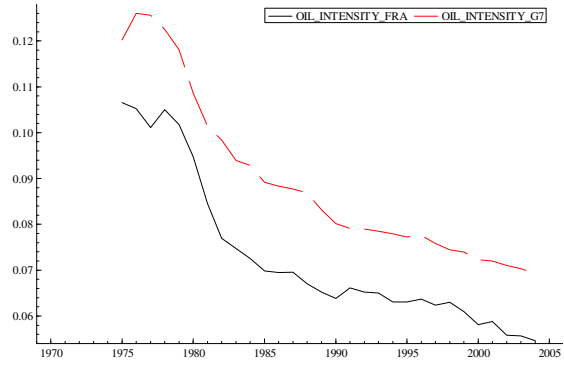

Figure 5: Energy intensity (oil products) of GDP at purchasing power parities (ktoe/GDP PPP) (Source: Our computations on data from Enerdata and World Development Indicators, World Bank)

a) Canada



b) France



b) Germany

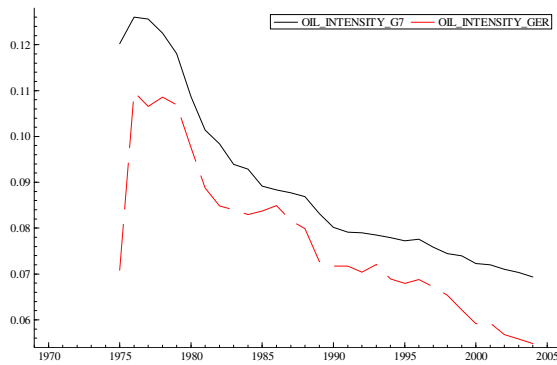

d) Italy

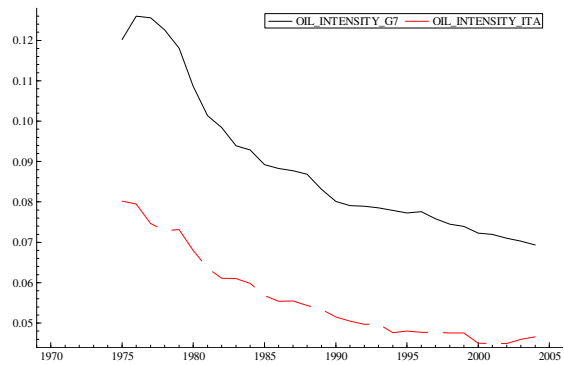

e) Japan

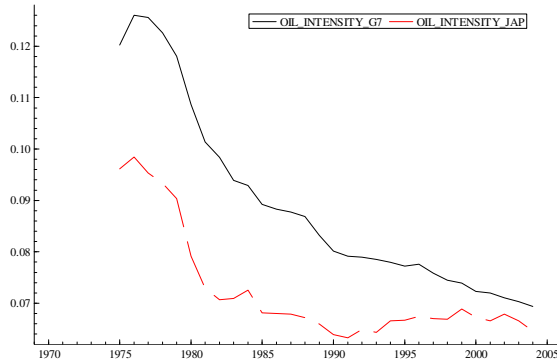

f) United Kingdom

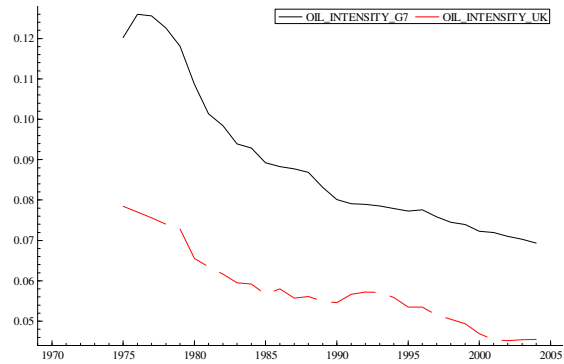

g) United States

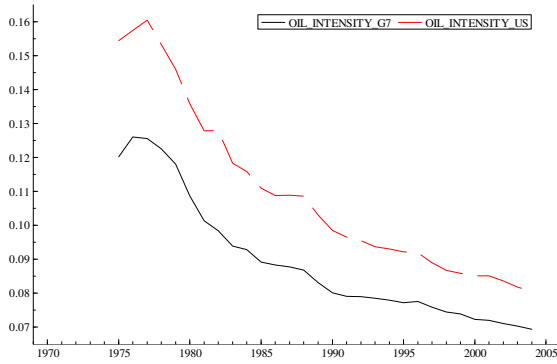
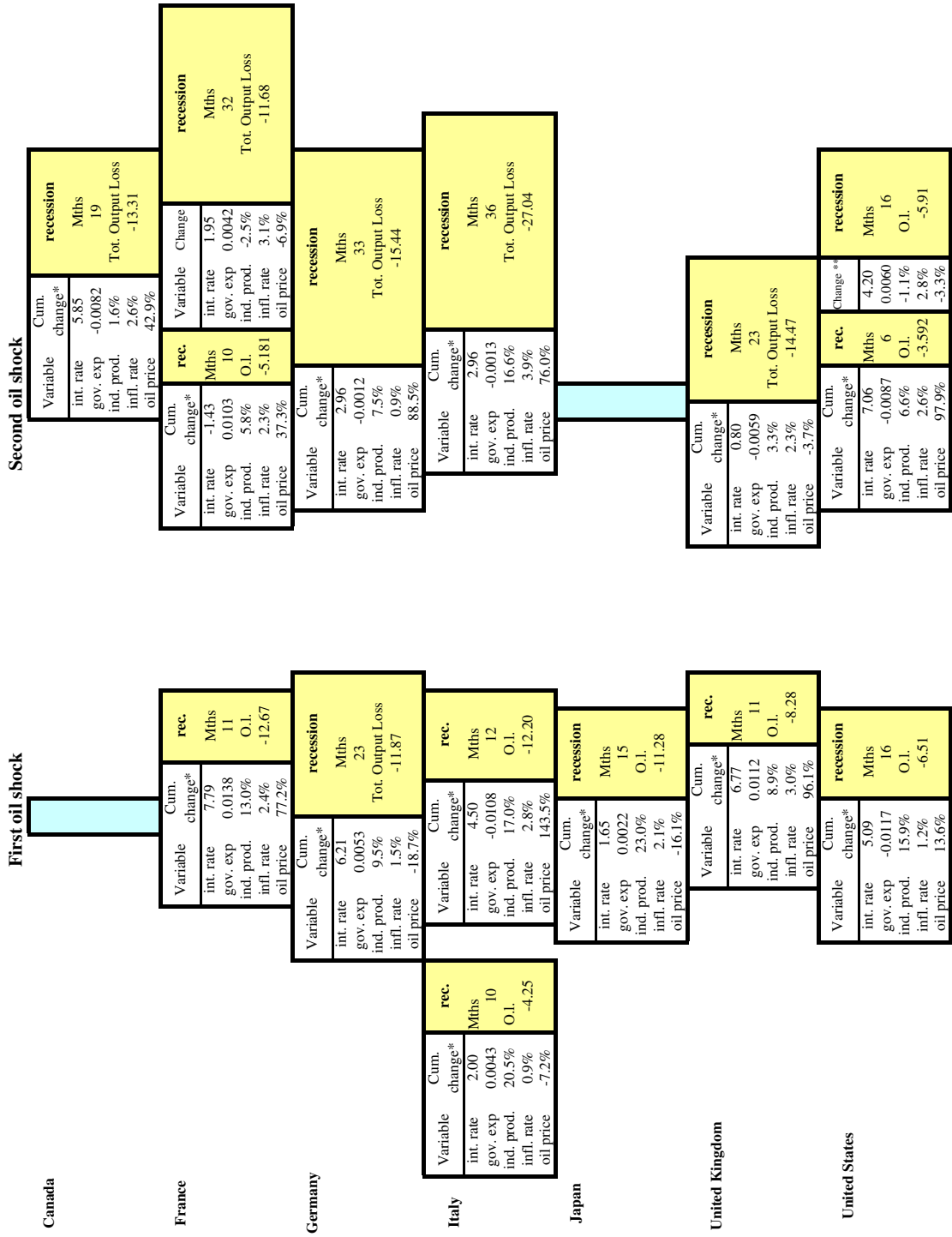
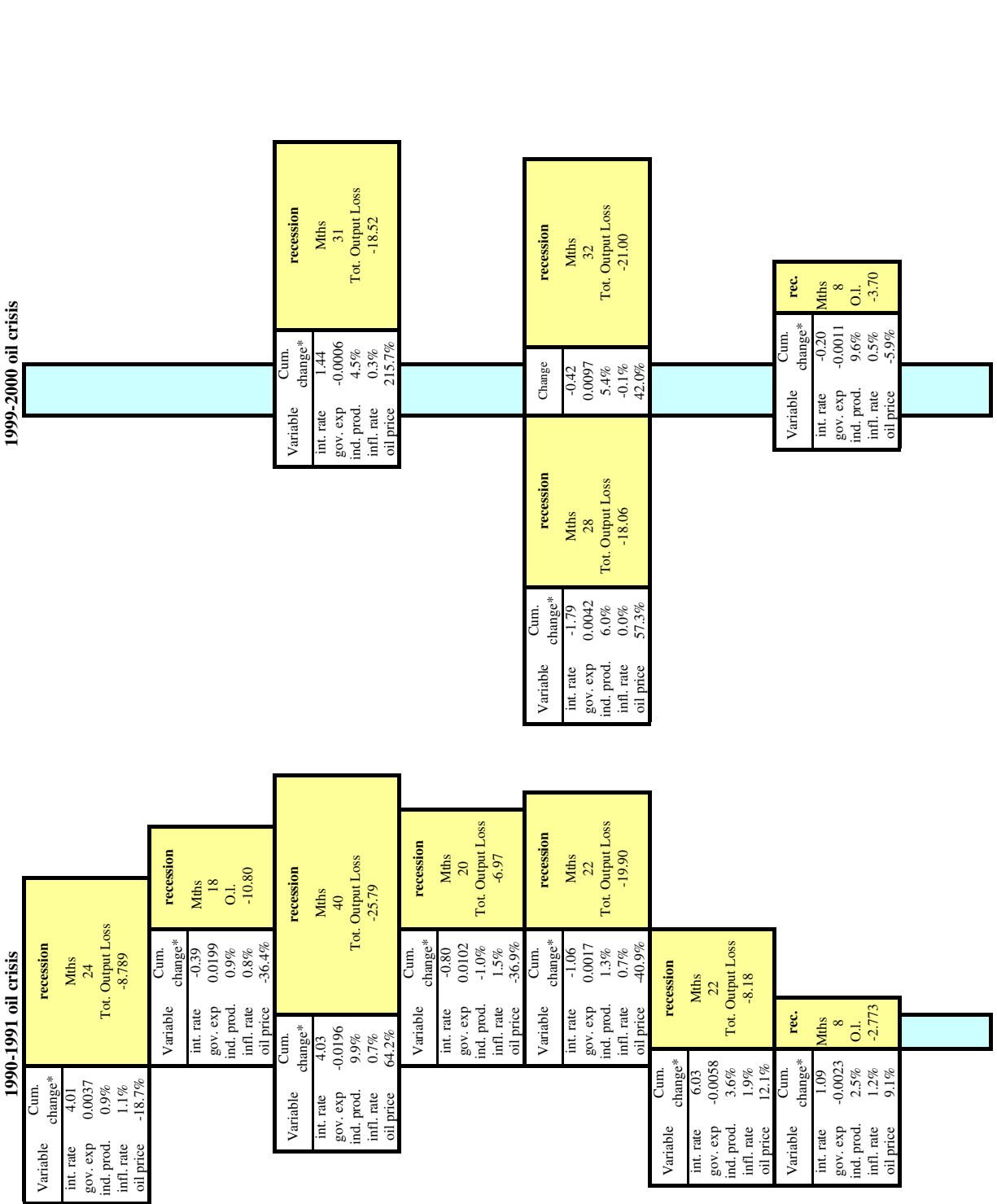

Table 6. Monetary and fiscal policy before recessions.  
 Year 1970 1971 1972 1973 1974 1975 1976 1977 1978 1979 1980 1981 1982 1983 1984 1985 1986 1987



Notes: oil prices refer to real oil prices expressed in local currency, government expenditure is expressed as ratio to GDP. Interest rates on Treasury-Bills are considered for the G-7 countries with the exception of Japan and U.S. for which we consider call money and Federal Funds interest rates, respectively. As far as the recessionary episodes of the early 1970s, for Germany and Italy, data for call money interest rates and discount rates are considered respectively. Changes are expressed in percentage points with the exception of interest rates and government expenditure (basis points). Mths and total output loss (O.L) refer to the time from peak to trough to the decrease in the industrial production index during the recessionary phase (as denoted by ECRI and NBER) expressed in percentage points, respectively. All data are from International Financial Statistics, International Monetary Fund (IFS, IMF). \* for inflation rate (based on the CPI) the entry refers to the average of the eight quarters; \*\* for the US (1981 recessions) we do not report data for quarters before the previous peak.

Table 6 (ctd). Monetary and fiscal policy before recessions. 1989 1990 1991 1992 1993 1994 1995 1996 1997 1998 1999 2000 2001 2002 2003 2004 2005



## NOTE DI LAVORO DELLA FONDAZIONE ENI ENRICO MATTEI

### Fondazione Eni Enrico Mattei Working Paper Series

Our Note di Lavoro are available on the Internet at the following addresses:

<http://www.feem.it/Feem/Pub/Publications/WPapers/default.html>

<http://www.ssrn.com/link/feem.html>

<http://www.repec.org>

<http://agecon.lib.umn.edu>

### NOTE DI LAVORO PUBLISHED IN 2006

SIEV	1.2006	<i>Anna ALBERINI</i> : <u>Determinants and Effects on Property Values of Participation in Voluntary Cleanup Programs: The Case of Colorado</u>
CCMP	2.2006	<i>Valentina BOSETTI, Carlo CARRARO and Marzio GALEOTTI</i> : <u>Stabilisation Targets, Technical Change and the Macroeconomic Costs of Climate Change Control</u>
CCMP	3.2006	<i>Roberto ROSON</i> : <u>Introducing Imperfect Competition in CGE Models: Technical Aspects and Implications</u>
KTHC	4.2006	<i>Sergio VERGALLI</i> : <u>The Role of Community in Migration Dynamics</u>
SIEV	5.2006	<i>Fabio GRAZI, Jeroen C.J.M. van den BERGH and Piet RIETVELD</i> : <u>Modeling Spatial Sustainability: Spatial Welfare Economics versus Ecological Footprint</u>
CCMP	6.2006	<i>Olivier DESCHENES and Michael GREENSTONE</i> : <u>The Economic Impacts of Climate Change: Evidence from Agricultural Profits and Random Fluctuations in Weather</u>
PRCG	7.2006	<i>Michele MORETTO and Paola VALBONESE</i> : <u>Firm Regulation and Profit-Sharing: A Real Option Approach</u>
SIEV	8.2006	<i>Anna ALBERINI and Aline CHIABAI</i> : <u>Discount Rates in Risk v. Money and Money v. Money Tradeoffs</u>
CTN	9.2006	<i>Jon X. EGUIA</i> : <u>United We Vote</u>
CTN	10.2006	<i>Shao CHIN SUNG and Dinko DIMITRO</i> : <u>A Taxonomy of Myopic Stability Concepts for Hedonic Games</u>
NRM	11.2006	<i>Fabio CERINA</i> (lxxviii): <u>Tourism Specialization and Sustainability: A Long-Run Policy Analysis</u>
NRM	12.2006	<i>Valentina BOSETTI, Mariaester CASSINELLI and Alessandro LANZA</i> (lxxviii): <u>Benchmarking in Tourism Destination, Keeping in Mind the Sustainable Paradigm</u>
CCMP	13.2006	<i>Jens HORBACH</i> : <u>Determinants of Environmental Innovation – New Evidence from German Panel Data Sources</u>
KTHC	14.2006	<i>Fabio SABATINI</i> : <u>Social Capital, Public Spending and the Quality of Economic Development: The Case of Italy</u>
KTHC	15.2006	<i>Fabio SABATINI</i> : <u>The Empirics of Social Capital and Economic Development: A Critical Perspective</u>
CSRM	16.2006	<i>Giuseppe DI VITA</i> : <u>Corruption, Exogenous Changes in Incentives and Deterrence</u>
CCMP	17.2006	<i>Rob B. DELLINK and Marjan W. HOFKES</i> : <u>The Timing of National Greenhouse Gas Emission Reductions in the Presence of Other Environmental Policies</u>
IEM	18.2006	<i>Philippe QUIRION</i> : <u>Distributional Impacts of Energy-Efficiency Certificates Vs. Taxes and Standards</u>
CTN	19.2006	<i>Somdeb LAHIRI</i> : <u>A Weak Bargaining Set for Contract Choice Problems</u>
CCMP	20.2006	<i>Massimiliano MAZZANTI and Roberto ZOBOLI</i> : <u>Examining the Factors Influencing Environmental Innovations</u>
SIEV	21.2006	<i>Y. Hossein FARZIN and Ken-ICHI AKAO</i> : <u>Non-pecuniary Work Incentive and Labor Supply</u>
CCMP	22.2006	<i>Marzio GALEOTTI, Matteo MANERA and Alessandro LANZA</i> : <u>On the Robustness of Robustness Checks of the Environmental Kuznets Curve</u>
NRM	23.2006	<i>Y. Hossein FARZIN and Ken-ICHI AKAO</i> : <u>When is it Optimal to Exhaust a Resource in a Finite Time?</u>
NRM	24.2006	<i>Y. Hossein FARZIN and Ken-ICHI AKAO</i> : <u>Non-pecuniary Value of Employment and Natural Resource Extinction</u>
SIEV	25.2006	<i>Lucia VERGANO and Paulo A.L.D. NUNES</i> : <u>Analysis and Evaluation of Ecosystem Resilience: An Economic Perspective</u>
SIEV	26.2006	<i>Danny CAMPBELL, W. George HUTCHINSON and Riccardo SCARPA</i> : <u>Using Discrete Choice Experiments to Derive Individual-Specific WTP Estimates for Landscape Improvements under Agri-Environmental Schemes: Evidence from the Rural Environment Protection Scheme in Ireland</u>
KTHC	27.2006	<i>Vincent M. OTTO, Timo KUOSMANEN and Ekko C. van IERLAND</i> : <u>Estimating Feedback Effect in Technical Change: A Frontier Approach</u>
CCMP	28.2006	<i>Giovanni BELLA</i> : <u>Uniqueness and Indeterminacy of Equilibria in a Model with Polluting Emissions</u>
IEM	29.2006	<i>Alessandro COLOGNI and Matteo MANERA</i> : <u>The Asymmetric Effects of Oil Shocks on Output Growth: A Markov-Switching Analysis for the G-7 Countries</u>

(lxxviii) This paper was presented at the Second International Conference on "Tourism and Sustainable Economic Development - Macro and Micro Economic Issues" jointly organised by CRENoS (Università di Cagliari and Sassari, Italy) and Fondazione Eni Enrico Mattei, Italy, and supported by the World Bank, Chia, Italy, 16-17 September 2005.

**2006 SERIES**

<b>CCMP</b>	<i>Climate Change Modelling and Policy</i> (Editor: Marzio Galeotti )
<b>SIEV</b>	<i>Sustainability Indicators and Environmental Valuation</i> (Editor: Anna Alberini)
<b>NRM</b>	<i>Natural Resources Management</i> (Editor: Carlo Giupponi)
<b>KTHC</b>	<i>Knowledge, Technology, Human Capital</i> (Editor: Gianmarco Ottaviano)
<b>IEM</b>	<i>International Energy Markets</i> (Editor: Anil Markandya)
<b>CSRМ</b>	<i>Corporate Social Responsibility and Sustainable Management</i> (Editor: Sabina Ratti)
<b>PRCG</b>	<i>Privatisation Regulation Corporate Governance</i> (Editor: Bernardo Bortolotti)
<b>ETA</b>	<i>Economic Theory and Applications</i> (Editor: Carlo Carraro)
<b>CTN</b>	<i>Coalition Theory Network</i>