

Kukharskyy, Bohdan

Working Paper

Quality of Institutions, Global Sourcing, and the Make-or-Buy Decision

BGPE Discussion Paper, No. 128

Provided in Cooperation with:

Friedrich-Alexander University of Erlangen-Nuremberg (FAU), Bavarian Graduate Program in Economics (BGPE)

Suggested Citation: Kukharskyy, Bohdan (2012) : Quality of Institutions, Global Sourcing, and the Make-or-Buy Decision, BGPE Discussion Paper, No. 128, Friedrich-Alexander-Universität Erlangen-Nürnberg, Bavarian Graduate Program in Economics (BGPE), Nürnberg

This Version is available at:

<https://hdl.handle.net/10419/73417>

Standard-Nutzungsbedingungen:

Die Dokumente auf EconStor dürfen zu eigenen wissenschaftlichen Zwecken und zum Privatgebrauch gespeichert und kopiert werden.

Sie dürfen die Dokumente nicht für öffentliche oder kommerzielle Zwecke vervielfältigen, öffentlich ausstellen, öffentlich zugänglich machen, vertreiben oder anderweitig nutzen.

Sofern die Verfasser die Dokumente unter Open-Content-Lizenzen (insbesondere CC-Lizenzen) zur Verfügung gestellt haben sollten, gelten abweichend von diesen Nutzungsbedingungen die in der dort genannten Lizenz gewährten Nutzungsrechte.

Terms of use:

Documents in EconStor may be saved and copied for your personal and scholarly purposes.

You are not to copy documents for public or commercial purposes, to exhibit the documents publicly, to make them publicly available on the internet, or to distribute or otherwise use the documents in public.

If the documents have been made available under an Open Content Licence (especially Creative Commons Licences), you may exercise further usage rights as specified in the indicated licence.



BGPE Discussion Paper

No. 128

**Quality of Institutions, Global Sourcing, and
the Make-or-Buy Decision**

Bohdan Kukharskyy

November 2012

ISSN 1863-5733

Editor: Prof. Regina T. Riphahn, Ph.D.
Friedrich-Alexander-University Erlangen-Nuremberg
© Bohdan Kukharskyy

Quality of Institutions, Global Sourcing, and the Make-or-Buy Decision*

Bohdan Kukharskyy[†]

University of Passau

November 22, 2012

Abstract

Do contractual institutions and a country's level of trust interact in their impact on the international make-or-buy decision? By analyzing explicit and implicit contracting in a unified framework, I show that better formal contractibility may both facilitate and hinder relational contracting on a trust basis. If formal agreements crowd out first-best efficient relational contracts, firms' profitability and consumers' welfare decrease. In contrast, a higher level of trust unambiguously increases firm performance and a country's attractiveness as an offshoring destination. I also show that improvements in the trust level are associated with largest reductions in intrafirm trade if formal contractibility is low. Lastly, this paper argues that models built on the simplifying assumption of ex ante lump-sum transfers between parties generally overestimate the prevalence of outsourcing vs. integration.

Keywords: International organization of production, institutional quality, relational contracting, interaction of explicit and implicit contracts, welfare

JEL-Classifications: D02, D23, F14, L22

*I am grateful to Pol Antràs, Michael Pflüger, Gabriel Smagghue and seminar participants in Goettingen (German Economic Society), Leuven (ETSG), Málaga (EEA), Passau and Munich for helpful comments and suggestions. Parts of this paper were written during my research stay at Harvard. I am thankful to Pol Antràs for making this visit possible. Financial support from the Bavarian Graduate Program in Economics is gratefully acknowledged. All errors and shortcomings are my own.

[†]Bohdan Kukharskyy, Faculty of Economics, University of Passau, Innstrasse 27, 94032 Passau, Germany, Tel (Fax) + 49 (0) 851 509-2536 (2532), E-mail: bohdan.kukharskyy@uni-passau.de.

1 Introduction

It is widely recognized that a country's ability to enforce written contracts may constitute a source of its comparative advantage. For instance, Nunn (2007) estimates that contract enforcement explains more of the pattern of trade than physical capital and skilled labor combined. At the same time, a recent body of literature stresses the role of informal institutions and social norms as a safeguard of international transactions. To mention just one example, Guiso et al. (2009) show that lower bilateral trust leads to less trade and less direct and portfolio investment between two countries. By considering both formal and informal institutions in a unified framework, this theoretical paper poses a simple research question: Is the joint impact of both institutional forms on the international make-or-buy decision just a sum of two individual effects or do they interact?

The distinction between formal and informal institutions dates back at least to North (1990) and, albeit not always clear-cut, provides some fundamental insights. Consider a situation in which an international transaction between a final good producer and an intermediate supplier bears the risk of a hold-up (e.g., due to relationship-specific investment). At a high level of abstraction, there are two mechanisms to counter both parties' potential opportunistic behavior. The first one is the law. If courts could perfectly verify and enforce contracts of any kind, cooperation parties could achieve the first-best outcome by stipulating in advance explicit agreements. However, most economists and legal scholars would agree that courts are constrained in their ability to verify and enforce all subjects of the contract (especially in the international context), and contracting parties are bounded in their abilities to stipulate all relevant variables in an enforceable agreement. Yet, the rule of law is not the only mechanism which facilitates economic exchange. In his widely-cited study, Macaulay (1963: 58) argues that "businessmen often rely on 'a man's word' in a brief letter, a hand-shake, or 'common honesty and decency' – even when the transaction involves exposure to serious risks."¹ The current paper considers these trust-based agreements as a second enforcement mechanism and refers to them as 'relational contracts'.

Existing theoretical models studying the impact of institutions on trade and foreign direct investment focus either on formal or informal institutions, thereby ignoring the interaction between these two forms and the net balance of their effect.² The need for a unifying theoretical framework becomes even more apparent in view of unexplained puzzles posed by recent empirical research. Using US firm-level data, Bernard et al. (2010a) analyze the interacting effect of 'product contractibility' and 'country governance' on the international

¹ Cf., e.g., McMillan and Woodruff (1999), Johnson et al. (2002) and references therein for the evidence.

² Cf. surveys by Anderson (2004) and Dixit (2009, 2011a, b), and the literature overview further below.

make-or-buy decision. They find that improvements in country governance lead to the largest reductions in intrafirm trade if product contractibility is low. According to Bernard et al. (2010b: 8), “this non-linearity in the role of the country contracting environment is not formally developed in existing theoretical models.” My model contributes to the understanding of this puzzle by showing that improvements in a country’s trust level is associated with higher prevalence of outsourcing if product contractibility is low.

The challenge of studying interacting effects of formal and informal institutions on the global sourcing decision lies in the appropriate modeling of these two institutional forms. In their seminal contribution, Antràs and Helpman (2008) suggest an intuitive way to capture the quality of formal institutions. Arguing that cooperation between a domestic headquarter and a foreign supplier requires from each party a range of specific activities, the authors assume that only a fraction of either party’s activities is verifiable and enforceable by the courts. Since the compensation of the residual activities is determined via future bargaining, both parties anticipate the potential hold-up and underinvest in the non-contractible activities. Given that parties in their model negotiate ex post ‘on the spot’, this type of cooperation will be referred throughout as *spot* contracting. By embedding the static framework by Antràs and Helpman (2008) into a repeated game environment similarly to Baker et al. (2002) and Halonen (2002), I show that inefficiencies of a spot contract may be avoided if parties are able to enter a *relational* agreement on a trust basis. Following a substantive literature strand, I choose the time preference rate in the repeated game as a proxy for bilateral trust in a relationship (cf., e.g., MacLeod 2007).³ Furthermore, I assume that countries may differ with respect to their (generalized) trust levels.⁴

In this model, the level of trust and the degree of contractibility may have diverging impacts on the *offshoring* decision. Given that a trust-based relationship with a supplier mitigates ex ante underperformance and increases firm profits, headquarters will primarily seek for contractors in those countries where cooperation partners are perceived to be more trustworthy. As a result, a higher level of trust unambiguously increases a country’s attractiveness from the viewpoint of international investors. Yet, given that better contracting institutions may deteriorate a firm’s ability to enter first-best efficient relational agreements with suppliers, the impact of formal institutions is ambiguous. Intuitively, if relational contracts can be more easily replaced by the ones based on formal enforcement, the loss of reputation due to the break-down of a trust-based agreement becomes less ‘costly’ to suppli-

³ Clearly, equating trust with a single proxy is as restrictive as measuring the quality of formal institutions via a fraction of a given range. However, as will be argued further below, these simple modeling choices are sufficient to obtain interesting interactions.

⁴ Country differences with respect to trust are well-documented in the literature, cf. Guiso et al. (2010). In this model, I treat this factor of comparative advantage as given and do not explore its origins, cf. Tabellini (2008). However, I discuss the effects of the change of trust level in the comparative statics.

ers. Therefore, formal and informal institutions may be both substitutes and complements. Since relational contracts are critical in overcoming inefficiencies associated with imperfect verifiability, crowding out of trust-based contracts has an adverse effect on the aggregate production and consumers' welfare in industry equilibrium.⁵

This paper also contributes to the understanding of the *make-or-buy* decision. Both under spot and relational contracting, the headquarters choose whether to *integrate* a supplier into firm boundaries or to acquire components through an arm's length transaction (*outsourcing*). Overall, my analysis thus allows for four organizational modes: spot integration and spot outsourcing, relational integration and relational outsourcing. It should be noticed at the outset that this analysis excludes ex ante lump-sum transfers between suppliers and headquarters. Consequently, unlike in Antràs and Helpman (2004, 2008), headquarters no longer accumulate the entire pure surplus from the current relationship. The reason for departure from this conventional assumption is twofold. First, the assumption of lump-sum transfers has been criticized in the literature for being hard to justify empirically, especially in the international context (cf., e.g., Antràs and Staiger (2011)). Second, I show that this assumption is not neutral with respect to the choice of the organizational form. More specifically, I argue that models with ex ante lump-sum transfers overestimate the prevalence of outsourcing as compared to integration. To provide the intuition behind this finding consider in turn the choice of organizational form under spot and relational contracting.

As it is well-known from Antràs and Helpman (2004, 2008), the make-or-buy decision in the *spot* game crucially depends on the relative importance of inputs provided by the two parties. In the spirit of the Property Rights Theory by Grossman and Hart (1986) and Hart and Moore (1990), they argue that a party making most important non-verifiable relationship-specific investment should possess residual control rights over the assets. More specifically, if the relative intensity of the supplier's input in the production process (hereafter, supplier intensity) is low enough, integration of a supplier into firm boundaries minimizes *joint* underinvestment and, thereby, maximizes *joint* pure profits. Conversely, if the supplier intensity is sufficiently high, spot outsourcing becomes a dominant organizational form. In the current model without lump-sum transfers, the relative attractiveness of integration is as well decreasing in the supplier intensity. Yet, spot outsourcing does *not* necessarily dominate spot integration for high levels of supplier intensity. This ambiguity depends on the

⁵ Using a principal-agent framework, Baker et al. (1994) and Schmidt and Schnitzer (1995) show that better contractibility of some of the agent's actions may render relational contracts on these actions infeasible. This model complements their findings in three respects. First, it generalizes their key result by showing that higher verifiability both of an agent's (supplier's) *and* a principal's (headquarter's) actions ambiguously affects the incentive compatibility of relational contracts. Second, it studies the associated welfare effects in industry equilibrium. Third, it argues that the choice of the organizational form (integration vs. outsourcing) affects as well the incentive compatibility of a relational agreement.

interplay of two opposing forces. Even though cooperation with a supplier at arm’s length maximizes *joint* pure profits for high supplier intensities, it lessens the headquarter’s ex post bargaining position and, therefore, her *share* of pure profits. Since the assumption of ex ante lump-sum transfers eliminates the latter effect, models built on this assumption overestimate the prevalence of outsourcing.

The make-or-buy decision in the *relational* game is as well governed by the supplier intensity. However, the ordering of organizational forms is reversed compared to the spot game: relational integration is a dominant organizational form if supplier intensity is high, whereas relational outsourcing is more likely to dominate relational integration the lower is supplier intensity. The intuition behind these diverging orderings resides in the different headquarter’s objectives under the two contractual types: While under spot contracting the organizational form is chosen so as to *maximize* headquarter’s profits resulting from the ex post bargaining, the role of organizational mode under relational contracting is to *minimize* supplier’s incentives to renege on the implicit agreement. Assuming that after deviation from a trust-based relationship a supplier is stuck forever with spot contracting, the headquarter minimizes supplier’s profits on the deviation path by choosing the organizational form which is *payoff-dominated* in the spot game.⁶

Lastly, this paper argues that formal and informal institutions interact in their impact on the international make-or-buy decision. When the level of trust in a particular country increases, international investors are more likely to cooperate with this country’s suppliers at arm’s length instead of integrating them into firm boundaries if the contractibility of headquarters’ activities is low. Intuitively, when suppliers become more trustworthy, they are more concerned about the ‘loss of reputation’ in case of the break-down of the trust-based relationship. As a response, the headquarter chooses the organizational form which makes this loss of reputation most costly for the supplier. The model argues that, if product contractibility is low, suppliers are worse off under outsourcing than under integration. Hence, arm’s length relationships are more likely to prevail in high-trust countries if product contractibility is low. This finding is well-aligned with empirical evidence presented above.

Apart from the above-mentioned contribution by Antràs and Helpman (2008), several authors study the impact of contracting institutions on the offshoring decision.⁷ Grossman and Helpman (2005) provide a general equilibrium model with partial contractibility of activities, in which final good producers decide whether to outsource intermediate production to a

⁶ Once again, I argue that the assumption of lump-sum transfers is not neutral regarding the organizational decision under relational contracting. Using this assumption in a repeated game similar to this paper, Kukharsky and Pflüger (2010) find that relational outsourcing (integration) will be chosen for low (high) supplier intensities. This reversed ordering results from the fact that headquarters in their model internalize supplier’s deviation incentives by demanding an organization-specific ex ante transfer.

⁷ Cf. Antràs (2011), Antràs and Rossi-Hansberg (2009) and Helpman (2006) for overviews.

local or a foreign supplier. In accordance with the current model, the authors show that the enhancement of foreign contracting institutions ambiguously affects the profitability of offshoring. However, their result is driven by the interplay of various general equilibrium effects and not the interaction between formal and informal contracts. Costinot (2009) provides a theoretical model and the supporting empirical evidence arguing that countries with better contracting institutions have comparative advantage in more complex industries. Similarly, Levchenko (2007) and Nunn (2007) provide both theoretical models and empirical results that confirm the link between contracting institutions and a country's comparative advantage. Two recent contributions by Corcos (2006) and Kukharsky and Pflüger (2010) argue that a country's ability to maintain relational agreements may as well constitute a source of comparative advantage. Yet, none of the mentioned papers simultaneously considers the effect of explicit *and* relational contracting on the offshoring and the make-or-buy decision.

The paper's structure is as follows. Section 2 lays out the basic set up. Section 3 analyzes firm behavior in the one-shot game. Section 4 embeds this behavior into a repeated game context and characterizes the choice between spot and relational contracting. Section 5 studies the locational choice and section 6 scrutinizes the make-or-buy decision. Section 7 concludes.

2 The basic set-up

The general setup of the model draws on Antràs and Helpman (2008), henceforth AH. The model economy consists of two countries: North and South, indexed by $\ell = N, S$. Each country is populated by a unit measure of consumers, who are symmetric in terms of their preferences. There are two types of internationally-immobile households: unskilled and skilled labor. Each household supplies inelastically one factor unit. While the North is endowed with both types of workers, the South only possesses the unskilled ones. Furthermore, N and S may differ with respect to the production cost, the quality of formal institutions, and the level of trust. These differences will be discussed in the due course.

Demand. All households derive their utility from consumption of the traditional good $q_{T\ell}$ and the bundle Q_ℓ of differentiated varieties v of the modern good $q_\ell(v)$. The utility function is assumed to be logarithmic quasi-linear with a CES sub-utility:

$$U_\ell = q_{T\ell} + \varepsilon \ln Q_\ell \quad , \quad Q_\ell = \left[\int_0^{n^w} q_\ell(v)^\alpha dv \right]^{1/\alpha} \quad , \quad \varepsilon > 0 \quad , \quad 0 < \alpha < 1 \quad , \quad \ell = N, S, \quad (1)$$

where n^w is the mass of varieties (firms) available in the world economy. Parameter ε measures the intensity of preferences for differentiated goods and α is a parameter related to

the elasticity of substitution between any two varieties, $\sigma = 1/(1-\alpha)$. The budget constraint reads $P_\ell Q_\ell + q_{T\ell} = Y_\ell$, where Y_ℓ denotes a household's income, $P_\ell \equiv \left[\int_0^{m^w} p_\ell(v)^{1-\sigma} dv \right]^{1/(1-\sigma)}$ the price index of the modern goods, and $p_\ell(v)$ represents the price of variety v in $\ell = N, S$. Standard utility maximization yields equilibrium demand functions for the modern goods bundle, a single differentiated variety, and the traditional good, respectively:⁸

$$Q_\ell = \varepsilon P_\ell^{-1} \quad , \quad q_\ell(v) = \varepsilon p_\ell(v)^{-\frac{1}{1-\alpha}} P_\ell^{\frac{\alpha}{1-\alpha}} \quad , \quad q_{T\ell} = Y_\ell - \varepsilon. \quad (2)$$

Using these functions in (1), yields a household's indirect utility (welfare):

$$W_\ell = Y_\ell + \varepsilon \ln Q_\ell - 1. \quad (3)$$

Production. The traditional good is produced in both countries under constant returns to scale and perfect competition. This good will be chosen as the numéraire. Production of one unit of output requires a_ℓ units of unskilled labor in region $\ell = N, S$. I assume that unskilled workers are more productive in the North than in the South, i.e., $a_N < a_S$. The numéraire good is assumed to be costlessly traded between two countries, implying the same (unity) price in both regions. Consequently, the model exhibits a constant wage differential between two countries: $w_N > w_S$.

The bundle of modern goods consists of a large variety of horizontally differentiated products. Production of each variety v requires two customized relationship-specific inputs: headquarter services X_h and manufacturing components X_m , supplied by headquarters H and manufacturing suppliers M , respectively. These inputs are costlessly combined to final goods according to the following Cobb-Douglas production function:

$$q = \left(\frac{X_h}{\eta_h} \right)^{\eta_h} \left(\frac{X_m}{\eta_m} \right)^{\eta_m} \quad , \quad X_j = \exp \left[\int_0^1 \log x_j(i) di \right] \quad , \quad j = h, m \quad , \quad 0 < \eta_h < 1 \quad , \quad \eta_m = 1 - \eta_h, \quad (4)$$

where η_h (η_m) represents the headquarter (supplier) intensity in the production of variety v . Following AH, I assume that each input $X_j = h, m$ is produced with a set of input-specific activities $x_j(i)$, indexed by points on the interval $[0, 1]$. Provision of a single manufacturing activity $x_m(i)$ in country $\ell = N, S$ requires a_ℓ units of unskilled labor. Production of headquarter services, however, requires one skilled worker as a fixed cost and a_ℓ units of unskilled labor per unit of output produced. Since skilled workers are available only in the North, $x_h(i)$ can be accomplished exclusively in N . I assume that final assembly of manufacturing components and headquarter services to final goods takes place in the North.

⁸ I assume sufficiently small preferences for differentiated goods (i.e., $\varepsilon < Y_\ell$) to ensure positive consumption of the traditional good in equilibrium.

International trade in manufacturing components is costly and $\tau > 1$ units of X_m need to be shipped from the South for one unit to arrive to the North. Alike, the shipment of final goods from N to S is associated with the same iceberg transport cost. Given the mill (fob.) price of final goods, $p_N(v)$, the price paid by consumers in the South is $p_S(v) = \tau p_N(v)$. Due to symmetry of final good producers, the price indices prevailing in N and S can be expressed as $P_N = (n^w)^{-\frac{1-\alpha}{\alpha}} p_N(v)$ and $P_S = \tau P_N$, respectively. Combining these results with equation (2), yields total demand for variety v , $q(v) = \varepsilon p_N(v)^{-\frac{1}{1-\alpha}} P_N^{\frac{\alpha}{1-\alpha}} + \tau \varepsilon (\tau p_N(v))^{-\frac{1}{1-\alpha}} (\tau P_N)^{\frac{\alpha}{1-\alpha}}$. Using the inverse of this equilibrium demand together with (4) and the fact that $P_N = \varepsilon Q_N^{-1}$ yields the revenue from the final goods production:

$$R(v) = 2^{1-\alpha} \varepsilon Q_N^{-\alpha} \left(\frac{X_h(v)}{\eta_h} \right)^{\alpha \eta_h} \left(\frac{X_m(v)}{\eta_m} \right)^{\alpha \eta_m}. \quad (5)$$

Notice that the revenue depends on the aggregate demand level Q_N . While this consumption index is exogenous from the viewpoint of a single producer, it is determined endogenously in the industry equilibrium. To save on notation, I drop the variety index v from now on.

I follow AH by assuming that input-specific activities are partially contractible. More specifically, while activities in the range $[0, \mu_{j\ell}]$ ($0 \leq \mu_{j\ell} \leq 1$, $j = h, m$, $\ell = N, S$) can be stipulated ex ante in an *explicit* contract, the residual activities $i \in (\mu_{j\ell}, 1]$ cannot be verified by the courts and, therefore, remain non-contractible. Notice that the fractions of contractible activities may vary both across goods and countries.

I depart, however, from AH in several respects. First and foremost, I embed the one-shot game between headquarters and manufacturers into a repeated game with infinitely lived agents. In doing so, I aim at capturing the notion that business cooperations involving relationship-specific investments are the ones where long-term relationships predominate. Hence, the parties in my model are allowed not only to negotiate on the spot (s) about the compensation of non-verifiable activities, but can also enter a relational agreement (r) on the trust basis, discussed at length further below. Secondly, as mentioned in the introduction, I rule out the assumption of ex ante lump-sum transfers between cooperation parties. Instead, I assume that potential suppliers may conduct promotional and/or rent-seeking activities ρ_ℓ (borne in terms of unskilled labor). Importantly, these activities do *not* inure to the benefit of headquarters, but increase M 's probability $\phi(\rho_\ell)$ of being selected by H as a cooperation partner. I further impose $\phi'(\rho_\ell) > 0$, $\lim_{\rho_\ell \rightarrow 0} \phi = 0$. Thirdly, I refrain from modeling productivity heterogeneity between firms.⁹

⁹ As shown in Kukharsky and Pflüger (2010), neither the choice of the governance mode (s vs. r), nor the make-or-buy decision is affected by the productivity differences between firms, as long as the fixed cost of production do not vary across governance and organizational modes.

Timing. The timing of events is as follows (cf. fig. 1):

- I. The headquarter chooses the location $\ell = N, S$ for production of manufacturing components. A large pool of potential suppliers anticipates future profits that can be earned via cooperating with H and undertakes promotional activities ρ_ℓ . Subsequently, H selects one of the (symmetric) manufacturing suppliers as a cooperation partner.
- II. The headquarter chooses the *governance mode* g : spot (s) vs. relational (r).

s : The consequent timing under spot contracting is as follows (see s -path in fig. 1):

- t_1 : H and M stipulate the following two components in the *explicit* contract: both parties' contractible (c) activities $\{x_{jcl}(i)\}_{i=0}^{\mu_{j\ell}}$ and the commitment of H to compensate M 's contractible activities with their marginal revenue product.
- t_2 : Both parties accomplish contractible activities and choose simultaneously and independently the amount of remaining non-contractible (n) activities, $\{x_{jn\ell}^s(i)\}_{i=\mu_{j\ell}}^1$.
- t_3 : H and M negotiate about the compensation of the latter's contribution with regard to non-contractible activities. I assume that H negotiates a share $\beta_{h\ell}$ of future revenue R_ℓ^s net of contractible payments, while M bargains a share $\beta_{m\ell} = 1 - \beta_{h\ell}$ of the net revenue. These shares are stipulated explicitly.
- t_4 : Manufacturing inputs are transferred to H , who combines them with headquarter services to final goods, cf. (4). The resulting output q_ℓ^s is sold in both countries.
- t_5 : The revenue is distributed between parties according to sharing rules stipulated in t_1 and t_3 .

r : The timing under relational contracting is as follows (see r -path in fig. 1):

- t_1 : H and M enter the following *implicit* agreement: both parties commit to provide the first-best level of non-verifiable activities $\{x_{jn\ell}^r(i)\}_{i=\mu_{j\ell}}^1$. Furthermore, H commits to pay a bonus B_ℓ to the supplier, if the latter sticks to this agreement.
- t_2 : Both parties' contractible activities $\{x_{jcl}(i)\}_{i=0}^{\mu_{j\ell}}$ and the commitment of H to compensate M 's contractible activities with their marginal revenue product are stipulated in the *explicit* contract.
- t_3 : Both parties accomplish contractible activities and choose simultaneously and independently the amount of remaining non-contractible activities, $\{x_{jn\ell}^r(i)\}_{i=\mu_{j\ell}}^1$.
- t_4 : Components are transferred to H and final goods q_ℓ^r are produced and sold.
- t_5 : The revenue is distributed according to sharing rules stipulated in t_1 and t_2 .

- III. The product cycle laid down above is repeated in all future periods $t = 0, \dots, \infty$.

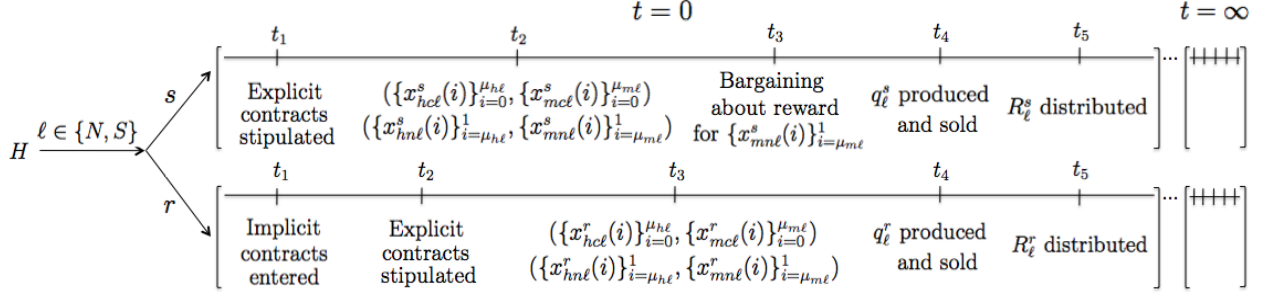

Figure 1: *Timing.*

Notice that this timing ignores H 's choice whether to integrate a supplier into firm boundaries or to cooperate with an independent M at arm's length. However, I take up the make-or-buy decision in section 6. The next section explores investment decisions of H and M and the corresponding firm profits in a single product cycle $t = 0$ under a given governance $g \in \{s, r\}$. I then extrapolate these results for all $t = 0, \dots, \infty$. Subsequently, I analyze H 's choice of governance mode. Lastly, H 's choice of a supplier's location $\ell \in \{N, S\}$ is determined.

3 One-shot game

Since H 's maximization problem is symmetrical in N and S , I suppress the index ℓ in this section. Before analyzing the choice of $g \in \{s, r\}$, consider first their common feature: explicit contracts with regard to verifiable activities. Under either governance mode firms stipulate the level of contractible activities $i \in [0, \mu_j]$ which maximize joint profits:

$$\max_{\substack{\{x_h(i)\}_{i=0}^{\mu_h} \\ \{x_m(i)\}_{i=0}^{\mu_m}}} \pi^g = R^g - c_h \int_0^1 x_h(i) di - c_m \int_0^1 x_m(i) di \Rightarrow x_j(i) \equiv x_{jc}^g = \left(\frac{\eta_j}{c_j}\right) \alpha R^g \quad (6)$$

where c_h and c_m are H 's and M 's per unit cost, defined for the ease of notation.¹⁰ Using x_{jc}^g in (5), the revenue in this *cooperative* game reads:

$$R^g = \left(Z \left[\exp \sum_{j=h,m} \alpha \eta_j \int_{\mu_j}^1 \log x_j^g(i) di \right] \right)^{\frac{1}{1-\alpha z}}, \quad (7)$$

$$\text{where } Z \equiv 2^{1-\alpha} \varepsilon Q_N^{-\alpha} \alpha^{\alpha z} \eta_h^{-\alpha \eta_h} \eta_m^{-\alpha \eta_m} \left(\frac{\eta_h}{c_h}\right)^{\alpha z_h} \left(\frac{\eta_m}{c_m}\right)^{\alpha z_m}, \quad z_j \equiv \eta_j \mu_j, \quad z \equiv z_h + z_m.$$

Recall that all contractible activities $\mu_j x_{jc}^g$ are rewarded with their marginal revenue product. Hence, the joint revenue net of compensations for contractible activities is given by $(1-\alpha z)R^g$ under either governance mode $g \in \{s, r\}$. In the following, I discuss how the choice of the governance mode affects the distribution of this net surplus between parties.

¹⁰ Notice that $c_h = w_N$ independent of a supplier's location, while $c_m = w_N$ ($c_m = \tau w_S$) if the supplier is located in N (respectively, S).

3.1 Spot governance

Consider date t_2 of the spot game. At this stage, H and M choose independently and simultaneously their levels of non-contractible activities $i \in (\mu_j, 1]$. Both players' maximization problems and the resulting Nash equilibrium of the *non-cooperative* game are given by

$$\max_{\{x_j(i)\}_{i=\mu_j}^1} \beta_j(1-\alpha z)R^s - c_j \int_{\mu_j}^1 x_j(i)di \quad \Rightarrow \quad x_j(i) \equiv x_{jn}^s = \beta_j \left(\frac{\eta_j}{c_j} \right) \alpha R^s, \quad \forall i \in (\mu_j, 1]. \quad (8)$$

It can be immediately seen from comparison of (6) and (8) that $x_{jn}^s < x_{jc}^g$ for any given $R^g = R^s$. Intuitively, each party anticipates a future hold-up on the part of the cooperation partner and underinvests with regard to non-verifiable activities. Utilizing x_{jn}^s in R^g from (7), yields the revenue under spot contracting:

$$R^s = (\beta_h^{\alpha\omega_h} \beta_m^{\alpha\omega_m})^{\frac{1}{1-\alpha}} (c_h^{-\alpha\eta_h} c_m^{-\alpha\eta_m})^{\frac{1}{1-\alpha}} 2AEQ_N^{-\frac{\alpha}{1-\alpha}}, \quad (9)$$

where $A \equiv \alpha^{\frac{\alpha}{1-\alpha}}$, $E \equiv \varepsilon^{\frac{1}{1-\alpha}}$, $\omega_j \equiv \eta_j(1 - \mu_j)$ are constants and $\omega_j \in (0, 1)$, $j = h, m$.

Utilizing R^s and x_{jn}^s in $\pi_H^s = \beta_h(1 - \alpha z)R^s - c_h(1 - \mu_h)x_{hn}^s$ and $\pi_M^s = \beta_m(1 - \alpha z)R^s - c_m(1 - \mu_m)x_{mn}^s$, yields H 's and M 's operating profits:

$$\begin{aligned} \pi_H^s &= \beta_h (\beta_h^{\alpha\omega_h} \beta_m^{\alpha\omega_m})^{\frac{1}{1-\alpha}} (1 - \alpha(1 - \omega_m)) (c_h^{-\alpha\eta_h} c_m^{-\alpha\eta_m})^{\frac{1}{1-\alpha}} 2AEQ_N^{-\frac{\alpha}{1-\alpha}}, \\ \pi_M^s &= \beta_m (\beta_h^{\alpha\omega_h} \beta_m^{\alpha\omega_m})^{\frac{1}{1-\alpha}} (1 - \alpha(1 - \omega_h)) (c_h^{-\alpha\eta_h} c_m^{-\alpha\eta_m})^{\frac{1}{1-\alpha}} 2AEQ_N^{-\frac{\alpha}{1-\alpha}}. \end{aligned} \quad (10)$$

Consider next both parties' participation constraints. Potential manufacturing suppliers anticipate ex post profit opportunities and adjust their promotional activities in order to increase the probability of being selected as a cooperation partner. The assumption of a large pool of potential suppliers implies $\phi(\rho) \pi_M^s - w\rho = 0$ in equilibrium. In words, M 's (expected) pure profits are distributed as wages to workers conducting promotional activities. In case of headquarters, one skilled worker (entrepreneur) is needed in order to start up a H firm. Since this entrepreneur is a scarce factor, she will appropriate all H 's operating profits. Yet, a skilled worker is willing to establish a new enterprise (instead of being employed as an unskilled worker) as long as the associated reward is higher than her opportunity cost, i.e., $\pi_H^s \geq w_N$. I assume in the following that H 's participation constraint always holds.

Notice that both parties' profits (π_H^s and π_M^s) depend via $\omega_j = \eta_j(1 - \mu_j)$ on the fraction of contractible activities, μ_j . Hence, joint profits under spot contracting, $\pi^s \equiv \pi_H^s + \pi_M^s$ are also dependent on μ_j . The following Lemma establishes these relationships:

LEMMA 1. (i) $\frac{\partial \pi^s}{\partial \mu_j} > 0$ for all $j = h, m$; (ii) $\frac{\partial \pi_H^s}{\partial \mu_h} > 0$ and $\frac{\partial \pi_M^s}{\partial \mu_m} > 0$; (iii) the sign of $\frac{\partial \pi_H^s}{\partial \mu_m}$

(resp., $\frac{\partial \pi_M^s}{\partial \mu_h}$) is ambiguous and is more likely to be positive the higher β_h and η_m (resp., β_m and η_h) and the lower μ_m (resp., μ_h); $\frac{\partial \pi_H^s}{\partial \mu_m} < 0$ if and only if $\beta_m > e^{-\frac{1-\alpha}{1-\alpha(1-\omega_m)}}$.

Proof. See Appendix A.

In the heart of part (i) of this Lemma lies the above-mentioned finding that the level of non-contractible activities is below the first-best optimal level of contractible activities. Since higher μ_j increases the relative weight of contractible activities in production, the joint underinvestment decreases and joint profits increase. The reaction of individual profits, however, depends on whose fraction of contractible activities increases. Part (ii) of Lemma 1 implies that each party is better off if a larger fraction of her *own* activities becomes contractible. Part (iii) shows that the effect of the increase in contractibility of the *counterpart's* activities on the profits of a particular party is ambiguous. To give the intuition for these two results, consider exemplary an increase in μ_h . Since H now becomes less exposed towards ex-post hold-up, the headquarter's ex ante investment rises, thereby increasing the revenue R^s and H 's profits. This increase in R^s also positively affects M 's profits. Yet, an increase in μ_h entails a further effect, which influences π_M^s in opposing direction. Higher μ_h implies a lower bargaining chip, which ceteris paribus decreases M 's profits. This counteracting effect is less important for M the higher is her ex post bargaining share β_m , the more headquarter investments relatively to manufacturing activities had been sunk (i.e, the higher is η_h), and the lower is the share μ_h of H 's activities covered by explicit contracts. The necessary condition for $\frac{\partial \pi_H^s}{\partial \mu_m} < 0$ has been derived for further purposes.

3.2 Relational governance

Consider now date t_1 of the relational game. At this stage, H and M *implicitly* commit to provide the amount of non-contractible activities which maximizes *joint* profits:

$$\max_{\substack{\{x_h(i)\}_{i=\mu_j}^1 \\ \{x_m(i)\}_{i=\mu_m}^1}} (1 - \alpha z) R^r - \sum_{j=h,m} c_j \int_{\mu_j}^1 x_j(i) di \quad \Rightarrow \quad x_j(i) \equiv x_{jn}^r = \left(\frac{\eta_j}{c_j} \right) \alpha R^r, \quad \forall i \in (\mu_j, 1].$$

Comparing this result with (6) immediately implies that, for any given $R^r = R^g$, the amount of non-contractible activities x_{jn}^r is equal to the *first-best* level of contractible activities, x_{je}^g . In other words, both parties implicitly agree not to underinvest with regard to non-contractible activities. Utilizing x_{jn}^r in R^g from (7) yields the revenue under relational contracting:

$$R^r = (c_h^{-\alpha \eta_h} c_m^{-\alpha \eta_m})^{\frac{1}{1-\alpha}} 2AEQ_N^{-\frac{\alpha}{1-\alpha}}. \quad (11)$$

It is apparent from the comparison of (9) and (11) that the revenue under a relational agreement is higher than under a spot contract. This results from the interplay of two effects. First, a higher amount of *non-contractible* activities under relational contracting, $x_{jn}^r > x_{jn}^s$, increases ceteris paribus the revenue. In turn, higher anticipated revenue leads to a greater amount of *contractible* activities, $x_{jc}^r > x_{jc}^s$, stipulated ex ante under a relational agreement. This second effect amplifies the first one and implies $R^r > R^s$ for all $\beta_j, \omega_j, \alpha \in (0, 1)$.

Apart from the mutual commitment to deliver a first-best amount of non-verifiable activities, H commits in t_1 to compensate M with a bonus B , if the supplier provides x_{mn}^r . Since this bonus is not enforceable by the courts, the headquarter can ex post refuse to provide B to the supplier. Yet, I show further below that if a relational contract is incentive-compatible, it is in the best interest of H to compensate M 's non-verifiable effort x_{mn}^r as agreed ex ante.

The operating profits of H and M are given by $\pi_H^r = (1 - \alpha z)R^r - c_h(1 - \mu_h)x_{hn}^r - B$ and $\pi_M^r = B - c_m(1 - \mu_m)x_{mn}^r$, respectively. Utilizing x_{jn}^r and R^r therein yields:

$$\begin{aligned}\pi_H^r &= (1 - \alpha(1 - \omega_m)) (c_h^{-\alpha\eta_h} c_m^{-\alpha\eta_m})^{\frac{1}{1-\alpha}} 2AEQ_N^{-\frac{\alpha}{1-\alpha}} - B \equiv \Pi_H^r - B, \\ \pi_M^r &= B - \alpha\omega_m (c_h^{-\alpha\eta_h} c_m^{-\alpha\eta_m})^{\frac{1}{1-\alpha}} 2AEQ_N^{-\frac{\alpha}{1-\alpha}} \equiv B - C_M^r,\end{aligned}\tag{12}$$

where Π_H^r and C_M^r are defined for the ease of notation. I show in section 4.1 that a bonus which renders a relational contract self-enforcing implies $\pi_M^r > 0$. Hence M 's participation constraint is always fulfilled. Furthermore, I derive therein a sufficient condition for H to be willing to participate in a relational agreement instead of negotiating on the spot.

Denote with $\pi^r \equiv \pi_H^r + \pi_M^r$ joint profits under relational contracting. The following Lemma establishes that this overall surplus is higher than joint surplus in the spot game:

LEMMA 2. It holds $\pi^r > \pi^s$ for all parameter values.

Proof. See Appendix B.

Once again, this finding results from the fact that a relational contract eliminates ex ante underinvestment and maximizes joint revenue.

3.3 Deviation path

Since the relational contract is implicit, each party may renege on it by providing a sub-optimal level of non-contractible activities. If either party deviates (D) from the implicit agreement, the relational contract is broken, and the distribution of this period's revenue R^D net of contractible payments occurs according to ex post bargaining with exogenous shares β_h and β_m .

Assume that a party $J = H, M$ sticks to the relational agreement and provides the first-

best efficient level of activities both in the contractible and non-contractible component, i.e., $x_{jc}^r = x_{jn}^r = \left(\frac{\eta_j}{c_j}\right) \alpha R^r$, where R^r is given by (11). In contrast, her counterpart $K = H, M$, $K \neq J$, while providing first-best efficient level of activities in the contractible component, $x_{kc}^r = \left(\frac{\eta_k}{c_k}\right) \alpha R^r$, reneges on relational contract and delivers $x_k^D(i)$ for all non-contractible activities $i \in (\mu_k, 1]$, $k = h, m$, whereas $k \neq j$. In this case, the surplus net of both parties' contractible activities is given by $\Lambda(x_k^D(i)) \equiv R(x_{jc}^r, x_{jn}^r, x_{kc}^r, x_k^D(i)) - c_h \mu_h x_{hc}^r - c_m \mu_m x_{mc}^r$. Deviation party's maximization problem thus reads:

$$\max_{\{x_k^D(i)\}_{i=\mu_k}^1} \beta_k \Lambda(x_k^D(i)) - c_k \int_{\mu_k}^1 x_k^D(i) di \Rightarrow x_k^D(i) \equiv x_{kn}^D = \beta_k \left(\frac{\eta_k}{c_k}\right) \alpha R^{DK}, \forall i \in (\mu_k, 1] \quad (13)$$

where
$$R^{DK} = \beta_k^{\frac{\alpha \omega_k}{1-\alpha \omega_k}} \left(c_h^{-\alpha \eta_h} c_m^{-\alpha \eta_m}\right)^{\frac{1}{1-\alpha}} 2AEQ_N^{-\frac{\alpha}{1-\alpha}}.$$

It can be easily verified that $x_{kn}^s < x_{kn}^D < x_{kn}^r$. In words, deviating party K underinvests comparing to the amount specified in the relational agreement, but still invests more than in the spot game.¹¹ Similarly, the following gradation of revenues results from the comparison of (9), (11) and (13): $R^s < R^{DK} < R^r$. Denote by π_H^{DH} party H 's profits (lower index) if this party (upper index) defects upon the relational agreement. By analogy, party M 's profits on the deviation path are defined as π_M^{DM} . Using (13) in $\pi_H^{DH} = \beta_h \Lambda - c_h(1 - \mu_h)x_{hn}^D$ and $\pi_M^{DM} = \beta_m \Lambda - c_m(1 - \mu_m)x_{mn}^D$, these profits read:

$$\begin{aligned} \pi_H^{DH} &= \beta_h \left[\beta_h^{\frac{\alpha \omega_h}{1-\alpha \omega_h}} (1 - \alpha \omega_h) - \alpha(1 - (\omega_h + \omega_m)) \right] \left(c_h^{-\alpha \eta_h} c_m^{-\alpha \eta_m}\right)^{\frac{1}{1-\alpha}} 2AEQ_N^{-\frac{\alpha}{1-\alpha}}, \\ \pi_M^{DM} &= \beta_m \left[\beta_m^{\frac{\alpha \omega_m}{1-\alpha \omega_m}} (1 - \alpha \omega_m) - \alpha(1 - (\omega_h + \omega_m)) \right] \left(c_h^{-\alpha \eta_h} c_m^{-\alpha \eta_m}\right)^{\frac{1}{1-\alpha}} 2AEQ_N^{-\frac{\alpha}{1-\alpha}}. \end{aligned} \quad (14)$$

Notice that, if β_m is low enough, π_M^{DM} may become negative. In this case, M would have no incentive to deviate. To exclude this uninteresting case I impose at the outset¹²

ASSUMPTION 1. $\beta_m > \left(\frac{\alpha(1-\omega_h-\omega_m)}{1-\alpha\omega_m}\right)^{\frac{1-\alpha\omega_m}{\alpha\omega_m}}$.

While either party's deviation profits may be both positive and negative, joint deviation incentives, $\pi^D \equiv \pi_H^{DH} + \pi_M^{DM}$, are strictly positive and larger than joint profits in a single period of a relational game:

LEMMA 3. It holds $\pi^D > \pi^r > 0$ for all $\alpha, \eta, \beta_j \in (0, 1)$, $j = h, m$.

Proof. See Appendix C.

Notice that π_H^{DH} , π_M^{DM} , and π^D depend via ω_j on the fraction of contractible activities, μ_j . The following Lemma establishes these relationships:

¹¹ This results from the complementarity of investments and the fact that cooperating party J invests under relational agreement more than under spot contracting, i.e. $x_{jn}^r > x_{jn}^s$.

¹² This assumption, however, is not decisive for any of the derived results except Proposition 6.

LEMMA 4. (i) $\frac{\partial \pi_H^{DH}}{\partial \mu_m} < 0$ and $\frac{\partial \pi_M^{DM}}{\partial \mu_h} < 0$; (ii) the sign of $\frac{\partial \pi_H^{DH}}{\partial \mu_h}$ (resp. $\frac{\partial \pi_M^{DM}}{\partial \mu_m}$) is ambiguous and is more likely to be negative the lower μ_h (resp. μ_m) and the higher η_h (resp. η_m); $\frac{\partial \pi_M^{DM}}{\partial \mu_m} > 0$ if and only if $\beta_m^{\frac{\alpha \omega_m}{1 - \alpha \omega_m}} (1 - \frac{\ln \beta_m}{1 - \alpha \omega_m}) > 1$; (iii) $\frac{\partial \pi^D}{\partial \mu_j} < 0$.

Proof. See Appendix D.

Part (i) of Lemma 4 argues that a party's deviation incentives decrease if her *counterpart's* activities become more contractible. To infer the intuition behind this result, consider exemplary an increase in μ_h . Recall that π_M^{DM} is constructed under the assumption that H complies to the implicit contract. That is, a variation of μ_h affects π_M^{DM} not via the change of H 's ex ante investment incentives. Instead, an increase in μ_h decreases the fraction of the ex post negotiable surplus and, thereby, decreases M 's profits in case of her deviation. Part (ii) implies that a party's profits are ambiguously affected by the increase in the contractibility of her *own* activities. This results from the interplay of two opposing effects. On the one hand, an increase in μ_h shifts the balance of H 's activities from suboptimally provided non-verifiable ones towards efficiently supplied contractible activities. The associated increase of revenue positively affects H 's deviation profits, π_H^{DH} . On the other hand, however, H 's ability to renege on the implicit agreement decreases. The latter effect reduces H 's deviation incentives. The condition for $\partial \pi_M^{DM} / \partial \mu_m > 0$ is derived for further purposes. Part (iii) establishes that, although the effect of μ_j on π_J^{DJ} is ambiguous, its negative effect on π_K^{DK} strictly dominates the former impact and leads to lower *joint* deviation incentives.

To sum up, section 3 lays down the investment decisions and profits for a *single* product cycle $t = 0$ under spot contracting and relational agreement (both on cooperation and deviation path). The next section embeds this one-shot game into a repeated game environment.

4 Repeated game

4.1 Set-up

Discount factor. I assume that players discount future profits and employ two specific assumptions in this regard. First, I follow the majority of contributions on the repeated games by assuming that cooperation parties share a *common* discount factor $\delta_\ell \equiv 1/(1 + d_\ell)$, $\delta_\ell \in [0, 1)$.¹³ Parameter d_ℓ represents joint per-period discount rate if M is located in $\ell = N, S$. The assumption of common discount factors, as restrictive as it is, can be justified by interpreting δ_ℓ as the probability of continuation of a particular relationship, conditional on time t being reached. To give economic interpretation of this technical concept,

¹³ See Mailath and Samuelson (2006) for an overview of this literature strand and Lehrer and Pauzner (1999) for discussion of limitations of this approach.

a lower discount rate d_ℓ is commonly associated with higher bilateral trust.¹⁴ I adopt this interpretation in what follows and use the terms (higher) trust and (lower) discount rates interchangeably. Second, I assume for simplicity that *all* pairs of H and M producing in country ℓ share the same discount factor. In this context, the common discount factor can be interpreted as a *generalized* level of trust, i.e., the trust towards a random counterpart.¹⁵ Notice also that the bilateral trust between a headquarter and a Northern supplier may differ from the level of trust prevailing in the relationship with a Southern supplier.¹⁶

Trigger strategies. As mentioned above, if either party deviates from the implicit agreement, the relational contract is broken. I assume that the party who did not renege refuses to enter into a new relational contract with the opportunistic party. Furthermore, I assume that neither of the existing partners can enter into a new relational agreement with a third party.¹⁷ Therefore, in case of a failure of a relational agreement in period $t = 0$ the two parties live forever (i.e., in $t = 1, \dots, \infty$) under a spot governance (cf. section 3.1). Table 1 illustrates both parties' profits on the cooperation and deviation path of a relational game.

Incentive compatibility constraints. H (resp., M) will honor rather than renege on the implicit contract if $\pi_{H\ell}^r + \frac{\pi_{H\ell}^r}{d_\ell} \geq \pi_{H\ell}^{DH} + \frac{\pi_{H\ell}^s}{d_\ell}$, (resp., $\pi_{M\ell}^r + \frac{\pi_{M\ell}^r}{d_\ell} \geq \pi_{M\ell}^{DM} + \frac{\pi_{M\ell}^s}{d_\ell}$). Rearranging these inequalities yields both firms' incentive compatibility constraints:

$$ICC_H : \frac{(\pi_{H\ell}^r - \pi_{H\ell}^s)}{d_\ell} \geq \pi_{H\ell}^{DH} - \pi_{H\ell}^r ; \quad ICC_M : \frac{(\pi_{M\ell}^r - \pi_{M\ell}^s)}{d_\ell} \geq \pi_{M\ell}^{DM} - \pi_{M\ell}^r ,$$

where $\pi_{J\ell}^s$, $\pi_{J\ell}^r$ and $\pi_{J\ell}^{DJ}$ are given by (10), (12) and (14), respectively. The left-hand side of ICC_J represents firm J 's present value from continuing a relational cooperation less the fallback if either party should renege. The right-hand side denotes a party's reneging temptation. The relational contract is self-enforcing if a party's one-shot gain from opportunistic behavior is outweighed by the loss of trust in the future. It can be easily verified that both incentive compatibility constraints are simultaneously fulfilled if the following ICC holds:

$$ICC : \frac{(\pi_\ell^r - \pi_\ell^s)}{d_\ell} \geq \pi_\ell^D - \pi_\ell^r \Leftrightarrow B_\ell \geq \frac{\pi_{M\ell}^s + d_\ell \pi_{M\ell}^{DM}}{1 + d_\ell} + C_{M\ell}^r. \quad (15)$$

¹⁴ See, for instance, James Jr. (2002), Kvaloy and Olson (2009) and MacLeod (2007) for this interpretation.

¹⁵ Generalized trust is commonly proxied in the empirical literature by the well-known World Values Survey Question: "Generally speaking, would you say that most people can be trusted or that you can't be too careful in dealing with people?"

¹⁶ Guiso et al. (2009) find that managers generally trust their fellow countrymen more than foreign partners. In terms of the current model, this 'home-country bias' would imply $d_N < d_S$.

¹⁷ This can be motivated by the assumption that all existing cooperations are registered in a Commercial Registry, which is common knowledge for all market participants. However, neither the terms of the relational contract nor the identity of the reneging party can be detected by a third person. By assuming that a party who was cheated upon in the relational contract cannot credibly signalize her cooperative behavior to third parties, no third party will have an incentive to enter into a new relational agreement with a party who just contracted out.

As long as this *ICC* holds, there exists a bonus B_ℓ which induces both parties' first-best activities in perpetuity. The headquarter implicitly stipulates the smallest possible bonus, which still fulfills the *ICC*. The equilibrium bonus is thus given by $B_\ell = \frac{\pi_{M\ell}^s + d_\ell \pi_{M\ell}^{DM}}{1 + d_\ell} + C_{M\ell}^r$.

J	Decision	$t = 0$	$t = 1$...	∞
H	Comply	$\pi_{H\ell}^r(x_{hcl}^r, x_{mcl}^r, x_{hnl}^r, x_{mnl}^r)$	$\frac{\pi_{H\ell}^r}{1 + d_\ell}$...	$\pi_{H\ell}^r + \sum_{t=1}^{\infty} \left(\frac{1}{1+d_\ell}\right)^t \pi_{H\ell}^r = \pi_{H\ell}^r + \frac{\pi_{H\ell}^r}{d_\ell}$
	Defect	$\pi_{H\ell}^{DH}(x_{hcl}^r, x_{mcl}^r, x_{hnl}^D, x_{mnl}^r)$	$\frac{\pi_{H\ell}^s}{1 + d_\ell}$...	$\pi_{H\ell}^{DH} + \sum_{t=1}^{\infty} \left(\frac{1}{1+d_\ell}\right)^t \pi_{H\ell}^s = \pi_{H\ell}^{DH} + \frac{\pi_{H\ell}^s}{d_\ell}$
M	Comply	$\pi_{M\ell}^r(x_{hcl}^r, x_{mcl}^r, x_{hnl}^r, x_{mnl}^r)$	$\frac{\pi_{M\ell}^r}{1 + d_\ell}$...	$\pi_{M\ell}^r + \sum_{t=1}^{\infty} \left(\frac{1}{1+d_\ell}\right)^t \pi_{M\ell}^r = \pi_{M\ell}^r + \frac{\pi_{M\ell}^r}{d_\ell}$
	Defect	$\pi_{M\ell}^{DM}(x_{hcl}^r, x_{mcl}^r, x_{hnl}^r, x_{mnl}^D)$	$\frac{\pi_{M\ell}^s}{1 + d_\ell}$...	$\pi_{M\ell}^{DM} + \sum_{t=1}^{\infty} \left(\frac{1}{1+d_\ell}\right)^t \pi_{M\ell}^s = \pi_{M\ell}^{DM} + \frac{\pi_{M\ell}^s}{d_\ell}$

Table 1: *Trigger strategy in the repeated game.*

Using Lemmas 2 and 3, it immediately follows that both sides of the *ICC* are positive for all parameter values. Hence, the *ICC* can be rearranged as:

$$\bar{d}_\ell \equiv \frac{\pi_\ell^r - \pi_\ell^s}{\pi_\ell^D - \pi_\ell^r} = \frac{(1 - \alpha) - \beta_{hl}^{\frac{\alpha\omega_{hl}}{1-\alpha}} \beta_{ml}^{\frac{\alpha\omega_{ml}}{1-\alpha}} (1 - \alpha[1 - \beta_{hl}\omega_{ml} - \beta_{ml}\omega_{hl}])}{\beta_{hl}^{\frac{1}{1-\alpha\omega_{hl}}} (1 - \alpha\omega_{hl}) + \beta_{ml}^{\frac{1}{1-\alpha\omega_{ml}}} (1 - \alpha\omega_{ml}) + \alpha(\omega_{hl} + \omega_{ml}) - 1}, \quad (16)$$

where \bar{d}_ℓ denotes the cutoff rate of time preference which satisfies the *ICC* with equality. If $d_\ell < \bar{d}_\ell$, cooperation parties can achieve the first-best outcome by means of relational contracting. Otherwise, the parties negotiate in each period on the spot.

Participation constraint. If *ICC* is fulfilled, M 's participation constraint is automatically satisfied. To see this, utilize the equilibrium bonus $B_\ell = \frac{\pi_{M\ell}^s + d_\ell \pi_{M\ell}^{DM}}{1 + d_\ell} + C_{M\ell}^r$ in equation (12) to obtain $\pi_{M\ell}^r = \frac{\pi_{M\ell}^s + d_\ell \pi_{M\ell}^{DM}}{1 + d_\ell}$. Since $\pi_{M\ell}^s$ from (10) is above zero for all parameter values and $\pi_{M\ell}^{DM} > 0$ under Assumption 1, M 's participation constraint is fulfilled. Yet, the mere fact that an implicit contract is self-enforcing does not necessarily implies H 's readiness to participate in a relational agreement. Since H transfers a fraction of pure profits π_ℓ^r to M , the headquarter is only willing to enter a relational contract if the remaining fraction overcompensates her profits under spot contracting, i.e., $\pi_{H\ell}^r + \frac{\pi_{H\ell}^r}{d_\ell} \geq \pi_{H\ell}^s + \frac{\pi_{H\ell}^s}{d_\ell}$. Recall that the *ICC* implies $\pi_{H\ell}^r + \frac{\pi_{H\ell}^r}{d_\ell} \geq \pi_{H\ell}^{DH} + \frac{\pi_{H\ell}^s}{d_\ell}$. It immediately follows that the *ICC* simultaneously fulfills H 's participation constraint, if and only if $\pi_{H\ell}^s \leq \pi_{H\ell}^{DH}$. If the latter inequality is not fulfilled, relational contract is never chosen in equilibrium. In order to make the tradeoff between relational and spot contracting relevant, I impose

ASSUMPTION 2. $\pi_{H\ell}^s \leq \pi_{H\ell}^{DH}$.

4.2 Interaction of explicit and implicit contracts in equilibrium

Notice that the degree of contractibility of either party's activities, $\mu_{j\ell}$ affects the cutoff time preference rate via two channels: $\pi_\ell^D(\omega_{j\ell}(\mu_{j\ell}))$ and $\pi_\ell^s(\omega_{j\ell}(\mu_{j\ell}))$, $j = h, m$. Recall from Lemma 4 that joint deviation profits π_ℓ^D decrease in $\mu_{j\ell}$. The associated increase in \bar{d}_ℓ implies ceteris paribus that implicit agreements are now sustainable for a larger range of d_ℓ . Intuitively, higher contractibility of either party's investment reduces the *immediate* gains from behaving opportunistically and, thus, makes implicit contracts relatively more attractive. At the same time, however, higher $\mu_{j\ell}$ leads to a larger π_ℓ^s , thereby decreasing \bar{d}_ℓ . Intuitively, higher contractibility decreases *future* "punishment" in case of the break-down of the relational agreement, thus making implicit contracts relatively less attractive. Since the reaction of \bar{d}_ℓ on the increase of the contractibility of activities is ambiguous, I maintain

PROPOSITION 1. Interaction of explicit and implicit contracts: An increase in the contractibility of either party's activities, may deteriorate the headquarters' ability to enter relational agreements with the suppliers.

Proof. Follows immediately from utilizing Lemma 1 and 4 in equation (16).

This proposition generalizes the key finding by Baker et al. (1994) and Schmidt and Schnitzer (1995), who show that higher contractibility of an *agent's* activities may crowd out a principal's ability to implement an implicit contract. The current model complements this result by showing that higher verifiability both of an agent's (M) and a principal's (H) actions ambiguously affects the incentive compatibility constraint. Furthermore, while the authors address single firms in partial equilibrium, my model can be used to assess the aggregate consequences of potential crowding out in industry equilibrium.

Consider, for instance, consumer's welfare. Denote with $V_{H\ell}^g \equiv \sum_{t=0}^{\infty} \left(\frac{1}{1+d_\ell}\right)^t \pi_{H\ell}^g = \frac{(1+d_\ell)}{d_\ell} \pi_{H\ell}^g$ the present value of H 's profit flow under a governance mode $g \in \{s, r\}$ if manufacturing supplier is located in ℓ . Due to the symmetry assumption, all headquarter firms face the same incentive compatibility constraint (16) and choose the same governance mode g^* . Skilled workers will found new firms as long as the present value of H 's profits under the optimal governance mode overcompensates the present value of their opportunity cost. If the mass of skilled workers is high enough, free entry ensures that these net present values equalize. The industry equilibrium is thus fully described by:

$$V_{H\ell}^{g^*}(Q_N^{g^*}) = \frac{(1+d_\ell)}{d_\ell} w_N. \quad (17)$$

Using (10), (12) and (15), it can be verified that the aggregate demand level in the equilibrium under relational contracting is higher than in the market where firms negotiate on the spot:

LEMMA 5. $Q_N^r > Q_N^s$.

Proof. See Appendix E.

The intuition behind this Lemma relies on the previous finding that relational contracts are helpful in overcoming inefficiencies associated with imperfect verifiability (cf. section 3.2). Higher output at the firm level gets reflected in a higher aggregate production. Given that skilled and unskilled workers in N obtain the same per-period wage, w_N (cf. (17)), using Lemma 5 in equation (3) immediately implies

PROPOSITION 2. Contractual environment and welfare: If higher formal contractibility crowds out relational agreements, consumers' welfare decreases.

Proof. Follows from using Lemma 5 in equation (3).

5 Location choice

The present value of a headquarter's profits under spot contracting is given by

$$V_{H\ell}^s = (w_N^{-\alpha\eta_h} c_{m\ell}^{-\alpha\eta_m})^{\frac{1}{1-\alpha}} 2AEQ_N^{-\frac{\alpha}{1-\alpha}} \Gamma_\ell^s \quad , \quad \Gamma_\ell^s = \frac{1+d_\ell}{d_\ell} \beta_{h\ell} (\beta_{h\ell}^{\alpha\omega_{h\ell}} \beta_{m\ell}^{\alpha\omega_{m\ell}})^{\frac{1}{1-\alpha}} (1 - \alpha(1 - \omega_{m\ell})).$$

Using B_ℓ from (15) in (12), yields the present value of H 's profits under relational contracting:

$$V_{H\ell}^r = \frac{(1+d_\ell)\pi_\ell^r - \pi_{M\ell}^s}{d_\ell} - \pi_{M\ell}^{DM} = (w_N^{-\alpha\eta_h} c_{m\ell}^{-\alpha\eta_m})^{\frac{1}{1-\alpha}} 2AEQ_N^{-\frac{\alpha}{1-\alpha}} \Gamma_\ell^r \quad , \quad \Gamma_\ell^r \equiv \left[\frac{1+d_\ell}{d_\ell} (1-\alpha) - \frac{\beta_{m\ell} (\beta_{h\ell}^{\alpha\omega_{h\ell}} \beta_{m\ell}^{\alpha\omega_{m\ell}})^{\frac{1}{1-\alpha}} (1 - \alpha(1 - \omega_{h\ell}))}{d_\ell} - \beta_{m\ell} \left(\beta_{m\ell}^{\frac{\alpha\omega_{m\ell}}{1-\alpha\omega_{m\ell}}} (1 - \alpha\omega_{m\ell}) - \alpha(1 - (\omega_{h\ell} + \omega_{m\ell})) \right) \right].$$

Using $V_{H\ell}^r$ and $V_{H\ell}^s$, and bearing in mind that $c_{mN} = w_N$ and $c_{mS} = \tau w_S$, the relative attractiveness of N as the destination location for manufacturing production is given by

$$V(w_S, d_S, \mu_{mS}) \equiv \frac{V_{HN}^{g^*}}{V_{HS}^{g^*}} = \left(\frac{w_N}{\tau w_S} \right)^{-\frac{\alpha\eta_m}{1-\alpha}} \frac{\Gamma_N^{g^*}}{\Gamma_S^{g^*}(d_S, \mu_{mS})}, \quad (18)$$

where $g^* \in \{s, r\}$ denotes the optimal governance mode from the viewpoint of headquarters. H prefers to cooperate with a Northern rather than a Southern supplier iff $V \geq 1$. Notice that V depends, among other things, on three sources of comparative (dis)advantage. First, a decrease in Southern wage rate, w_S reduces production cost in S and, thereby, decreases the relative attractiveness of N . Second, if Southern suppliers become more long-term oriented (i.e. d_S falls), the relative attractiveness of N decreases even further.¹⁸ However, as argued below, the effect of the increase in contractibility in the South is ambiguous.

¹⁸ Notice that $\partial\Gamma_S^s/\partial d_\ell < 0$ and $\partial\Gamma_S^r/\partial d_\ell < 0$ due to Lemma 2.

Assume first that the offshoring to S under relational contracting is *not* possible, i.e. $V_{HS}^{g*} = V_{HS}^s$. Recall from part (iii) of Lemma 1 that the reaction of π_{HS}^s on the increase in μ_{mS} is ambiguous. Since Γ_S^s is a positive monotone function of π_{HS}^s , $V'(\mu_{mS}) \geq 0$ cannot be assigned without ambiguity. Bearing in mind the condition derived in Lemma 1, V_{HS}^s is decreasing in μ_{mS} if $\beta_{mS} > e^{-\frac{1-\alpha}{1-\alpha\omega_{mS}}}$. In words, if a supplier's ex post bargaining share is sufficiently high, an increase in the contractibility of Southern manufacturing activities decreases the relative attractiveness of S . Assume next that the relational contracting in the South is self-enforcing, i.e. $V_{HS}^{g*} = V_{HS}^r$. $V_{HS}^r(\mu_{mS})$ depends on the fraction of M 's contractible activities via two channels: $\pi_{MS}^s(\mu_{mS})$ and $\pi_{MS}^{DM}(\mu_{mS})$. Recall from part (ii) of Lemma 1 and part (ii) of Lemma 4 that π_{MS}^s is always increasing in μ_{mS} , whereas π_{MS}^{DM} is increasing in μ_{mS} if and only if $\beta_{mS}^{\frac{\alpha\omega_{mS}}{1-\alpha\omega_{mS}}} (1 - \frac{\ln \beta_{mS}}{1-\alpha\omega_{mS}}) > 1$. If this condition is fulfilled, V_{HS}^r is decreasing and, thus, V from (18) is increasing in μ_{mS} . Intuitively, if better contractibility of Southern manufacturing activities increases M 's deviation profits, the headquarter has to pay a larger bonus B_S in order to restore the incentive compatibility of the supplier. This diminishes the relative attractiveness of S from the viewpoint of H . As shown in Appendix F, the two above mentioned conditions for $V'(\mu_{mS}) > 0$ can be simultaneously fulfilled in this model. This implies:

PROPOSITION 3. The offshoring decision: Manufacturing production is more likely to be offshored from N to S the higher is S 's relative cost advantage. A rise in Southern level of trust increases the prevalence of offshoring. An increase in the contractibility of Southern manufacturing activities has an ambiguous impact on the relative attractiveness of offshoring as compared to home sourcing. If the conditions from Lemmas 1 and 4 are fulfilled, better contracting institutions in the South decrease the relative attractiveness of offshoring.

Proof. Follows from the discussion above.

While the first result is intuitive and can be found just as well in Antràs and Helpman (2008), the further two findings are new to the trade literature. The second result is a direct implication of the repeated game nature of the current framework. In the spirit of the Folk theorem, a higher country-level of trust fosters relational contracting between cooperation parties and, thereby, increases this country's attractiveness from the viewpoint of international investors. The third result argues that, independent of the optimal governance mode $g \in \{s, r\}$ in a particular country, this country may loose in terms of inward foreign direct investment due to better contracting institutions. While the intuition behind this surprising result has been discussed in detail above, it should be underlined that the 'no ex ante transfers' assumption lies in the heart of this finding. If these AH-type lump-sum transfers were possible, the headquarter would accumulate joint ex post profits and the

ambiguity would disappear (cf. part (i) of Lemma 1 and part (iii) of Lemma 4). I thus conclude that the commonly made assumption of ex ante lump-sum transfers is not only questionable empirically, but may also conceal some theoretical insights.

6 The Make-or-buy decision

In addition to the decision about the location $\ell \in \{N, S\}$ and the governance mode $g \in \{r, s\}$, the headquarter can now decide whether to integrate (I) a supplier or to outsource (O) the manufacturing production to an independent M . The chosen organizational form $F \in \{I, O\}$ is stipulated explicitly and enforceable by the courts. For simplicity, I assume that this organizational form prevails in all future periods of the game (i.e., even if the relational agreement breaks down). Figure 2 summarizes the extended timing, whereby the repeated game evolving under either organizational form is identical to the one specified in Figure 1.

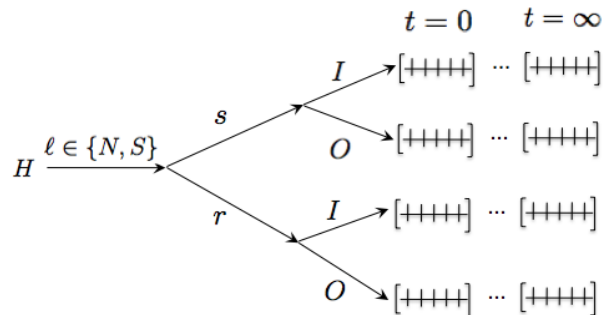

Figure 2: *Extended timing.*

Following the Property Rights Theory of the firm by Grossman and Hart (1986) and Hart and Moore (1990), I assume that ex post bargaining about the reward of non-contractible investments takes place both under integration and outsourcing. However, the distribution of surplus is sensitive to the organizational form. I, thereby, follow Antràs (2003) and Antràs and Helpman (2004, 2008) by assuming that the headquarter will obtain a greater share of surplus under vertical integration than under outsourcing:¹⁹

ASSUMPTION 3. $\beta_{h\ell I} > \beta_{h\ell O}$.

6.1 Make-or-buy decision under spot contracting

Consider first the organizational choice of a headquarter who decides in favor of spot cooperation with a supplier in country ℓ (see upper path in fig. 2). Using (10) and substituting β_j with organization-specific $\beta_{j\ell F}$, the ratio of H 's profits under spot integration vs. spot outsourcing reads:

¹⁹ The intuition behind this assumption lies in the reasoning that, by integrating a supplier, the headquarter obtains property rights for the supplier's assets and therefore gets a greater outside option if the current cooperation breaks down. This implies a higher H 's ex post bargaining position under I .

$$\Theta_{H\ell}^s(\eta_h) \equiv \frac{\pi_{H\ell I}^s}{\pi_{H\ell O}^s} = \frac{\beta_{h\ell I}}{\beta_{h\ell O}} \frac{R_{\ell I}^s}{R_{\ell O}^s} = \frac{\beta_{h\ell I}}{\beta_{h\ell O}} \frac{(\beta_{h\ell I}^{\alpha\omega_{h\ell}} \beta_{m\ell I}^{\alpha\omega_{m\ell}})^{\frac{1}{1-\alpha}}}{(\beta_{h\ell O}^{\alpha\omega_{h\ell}} \beta_{m\ell O}^{\alpha\omega_{m\ell}})^{\frac{1}{1-\alpha}}}. \quad (19)$$

The headquarter strictly prefers integration over outsourcing if $\Theta_{H\ell}^s > 1$. I show in Appendix G that the relative attractiveness of spot outsourcing decreases in the headquarter intensity η_h . This result is closely related to Proposition 2 in Antràs and Helpman (2008). Intuitively, if supplier's activities become less important in the production process, the need for incentivizing M 's ex ante investment via outsourcing decreases. Despite of common intuition, this result is complementary to Antràs and Helpman (2008), since it does not rely on the simplifying assumption of ex ante lump-sum transfers.

A direct implication of these altering assumptions stands out in a further result derived in Appendix G. In accordance with Proposition 3 in Antràs and Helpman (2008), spot integration is the strictly dominant organizational form for sufficiently high headquarter intensities. Unlike in AH, however, spot integration is not necessarily dominated by spot outsourcing for sufficiently low η_h . Outsourcing is more likely to be chosen as the organizational form in this range if μ_m is sufficiently low and β_{hI} sufficiently high. Both results are intuitive since lower contractibility of M 's inputs and better H 's ex post bargaining position make a supplier more prone towards ex post hold-up and, thereby, adversely affect her ex ante investment incentives. A headquarter may restore these incentives by providing a supplier with the property rights for manufacturing inputs.

Furthermore, I show in Appendix G that the relative attractiveness of spot integration is increasing in the fraction of M 's contractible activities $\mu_{m\ell}$ and decreasing in the fraction of H 's contractible activities $\mu_{h\ell}$. Intuitively, an increase in $\mu_{m\ell}$ or a decrease in $\mu_{h\ell}$ makes M less prone to be held up ex post by H , thereby decreasing the need for incentivizing M 's investment via outsourcing. All above-mentioned results are summarized in

PROPOSITION 4. Organizational choice under spot contracting: The relative attractiveness of spot integration as compared to spot outsourcing is increasing in the fraction of M 's contractible activities $\mu_{m\ell}$, decreasing in the fraction of H 's contractible activities $\mu_{h\ell}$ and increasing in the headquarter intensity η_h . While integration is a strictly dominant organizational form at high levels of η_h , outsourcing is more likely to dominate integration for low η_h the lower $\mu_{m\ell}$ and the higher β_{hI} .

Proof. See Appendix G.

Consider once again the distinction between this Proposition and the Proposition 3 in Antràs and Helpman (2008). While the AH model predicts the existence of a single cutoff η_{hc} , such that for all $\eta_h < \eta_{hc}$ (resp. $\eta_h > \eta_{hc}$) outsourcing (resp. integration) is chosen as

the organizational form, this unique cutoff exists in this model only if $\mu_{m\ell}$ is sufficiently low and β_{hI} sufficiently high. Otherwise, spot integration is the optimal organizational form for *all* permissible values of η_h . This diverging finding is a direct implication of this model's ‘no ex ante transfers’ assumption. Intuitively, since a headquarter obtains only a *share* of ex post pure profits in this model, she is less concerned about internalizing the effect of a supplier's activities on the *joint* profits. Therefore, outsourcing in the model is chosen less frequently as compared to the case with ex ante lump-sum transfers.

6.2 Make-or-buy decision under relational contracting

Assume next that a headquarter enters a relational agreement with a manufacturing producer in ℓ (see lower path in fig. 2). The headquarter strictly prefers relational integration over relational outsourcing if $\pi_{H\ell I}^r > \pi_{H\ell O}^r$. Utilizing equilibrium bonus from (15) in (12), this condition reads $\pi_\ell^r - \frac{\pi_{M\ell I}^s + d_\ell \pi_{M\ell I}^{DM}}{1+d_\ell} > \pi_\ell^r - \frac{\pi_{M\ell O}^s + d_\ell \pi_{M\ell O}^{DM}}{1+d_\ell}$. It immediately follows that relational integration is a strictly dominant organizational form if and only if

$$\Theta_{M\ell}^r(\eta_h) \equiv \frac{\pi_{M\ell O}^{DM} + \frac{\pi_{M\ell O}^s}{d_\ell}}{\pi_{M\ell I}^{DM} + \frac{\pi_{M\ell I}^s}{d_\ell}} \quad (20)$$

is greater than one. Notice that, in contrast to (19), this function involves solely M 's profits. This reflects different headquarter's objectives under the two contractual types. While under spot contracting the organizational form is chosen so as to *maximize* headquarter's profits from the ex post bargaining, optimal organizational form under relational contracting *minimizes* supplier's profits on the deviation path.²⁰

In order to infer the intuition behind the choice of the organization form, consider first the rate of M 's one-shot deviation profits under outsourcing vs. integration:

$$\Theta_{M\ell}^{DM}(\eta_h) \equiv \frac{\pi_{M\ell O}^{DM}}{\pi_{M\ell I}^{DM}} = \frac{\beta_{m\ell O} \left[\beta_{m\ell O}^{\frac{\alpha\omega_{m\ell}}{1-\alpha\omega_{m\ell}}} (1 - \alpha\omega_{m\ell}) - \alpha(1 - (\omega_{h\ell} + \omega_{m\ell})) \right]}{\beta_{m\ell I} \left[\beta_{m\ell I}^{\frac{\alpha\omega_{m\ell}}{1-\alpha\omega_{m\ell}}} (1 - \alpha\omega_{m\ell}) - \alpha(1 - (\omega_{h\ell} + \omega_{m\ell})) \right]}. \quad (21)$$

Given that $\beta_{m\ell O} > \beta_{m\ell I}$ (cf. Assumption 3), $\Theta_{M\ell}^{DM}(\eta_h) > 1$ for all permissible parameter values. In words, since a deviation from the relational agreement provides a lower fraction of surplus to an integrated as compared to an arm's length producer, relational integration minimizes her one-shot deviation incentives. Hence, if M 's profits on the deviation path would consist only of the one-shot deviation profits, relational outsourcing would never be

²⁰ Since lower M 's profits on the deviation path imply lower equilibrium bonus (cf. (15)), the headquarter, thereby, indirectly maximizes her pure profits under a relational agreement.

chosen as an organizational form.

Recall, however, that cooperation parties in this model interact under spot governance mode after the trust-based relationship has been broken. M 's profits under spot outsourcing vs. spot integration in any period $t = 1, \dots, \infty$ on the deviation path read

$$\Theta_{M\ell}^s(\eta_h) \equiv \frac{\pi_{M\ell O}^s}{\pi_{M\ell I}^s} = \frac{\beta_{m\ell O} R_{\ell O}^s}{\beta_{m\ell I} R_{\ell I}^s} = \frac{\beta_{m\ell O}}{\beta_{m\ell I}} \frac{(\beta_{h\ell O}^{\alpha\omega_{h\ell}} \beta_{m\ell O}^{\alpha\omega_{m\ell}})^{\frac{1}{1-\alpha}}}{(\beta_{h\ell I}^{\alpha\omega_{h\ell}} \beta_{m\ell I}^{\alpha\omega_{m\ell}})^{\frac{1}{1-\alpha}}}. \quad (22)$$

It has been already established above (cf. equation (19)) that the ratio $R_{\ell I}^s/R_{\ell O}^s$ is increasing in the headquarter intensity, η_h . Hence $\Theta_{M\ell}^s(\eta_h)$ decreases in η_h . The logic behind this result is in accordance with Proposition 4. Since spot integration is associated with lower joint underinvestment and higher negotiable profits at high values of η_h , the relative attractiveness of spot outsourcing from the viewpoint of M decreases in η_h . Yet, under relational contracting the headquarter aims at choosing the organizational form which *minimizes* (and not *maximizes*) M 's profits. In other words, H chooses the organizational form which is *payoff-dominated* from the viewpoint of M . Notice from using $\beta_{m\ell O} > \beta_{m\ell I}$ in (22) that $\Theta_{M\ell}^s(0) > 1$. That is, relational integration is the superior organizational form from the viewpoint of H at the lowest values of η_h . Although $\Theta_{M\ell}^s(\eta_h)$ decreases in η_h , the relationship $\Theta_{M\ell}^s(1) \geq 1$ cannot be assigned without ambiguity. That is, outsourcing does not necessarily become H 's preferable organizational form at high levels of η_h .

The choice of the organizational form under relational game combines the insights from equations (21) and (22). Notice from (20) that $\Theta_{M\ell}^r(0) > 1$ under Assumption 3. That is, integration is a dominant organizational form for low headquarter intensities. Since $\Theta_{M\ell}^r(1) \geq 1$ cannot be assigned without ambiguity, the choice of the organizational form for high headquarter intensities is ambiguous. However, I verify numerically that $\Theta_{M\ell}^r(\eta_h)$ is decreasing in η_h for all parameter values.²¹ Hence, the headquarters are more likely to enter a relational agreement with an arm's length supplier the higher is η_h . These results are summarized in

PROPOSITION 5. Organizational choice under relational contracting: Integration is a strictly dominant organizational form for low levels of headquarter intensity. The relative attractiveness of outsourcing increases in the headquarter intensity η_h .

Proof. Follows immediately from the discussion above.

This Proposition deserves critical reflection in two respects. First, it should be noticed from the comparison of Propositions 4 and 5 that the headquarter intensity affects the prevalence of organizational forms under spot and relational contracting in a diametrically

²¹ The computations were performed in MAPLE and are available upon request.

opposed ways. The logic behind these diverging impacts lies in the opposite roles of the organizational form under the two governance modes. While under spot contracting the organizational form is chosen so as to *maximize* H 's profits resulting from the ex post bargaining, under relational contracting it aims at *minimizing* M 's deviation incentives. Second, this Proposition contrasts Proposition 3 in Kukharsky and Pflüger (2010) who show that relational outsourcing is chosen for low headquarter intensity and that the prevalence of relational outsourcing *decreases* in η_h . They obtain this diametrically opposed finding in a model with ex ante lump-sum transfers. More specifically, headquarters in their model can internalize organization-specific deviation incentives by adjusting the level of the ex ante transfer. This mechanism is foreclosed in the current model, which does not allow for these transfers. As a result, outsourcing is chosen less frequently under relational contracting. Similarly to the discussion of the Proposition 4, I conclude that the assumption of ex ante transfers is not neutral with regard to the predicted prevalence of organizational forms.

Finally, notice from (20) that the choice of organizational form depends among other things on d_ℓ , whereby the latter parameter is an inverse proxy of a country's (generalized) level of trust. I show in Appendix H that $\Theta_{M\ell}^r$ is more likely to increase in d_ℓ the lower is $\mu_{h\ell}$. Bearing in mind that lower $\Theta_{M\ell}^r$ represents greater attractiveness of outsourcing, I maintain

PROPOSITION 6. Trust, contracts, and the make-or-buy decision: When the level of trust in S increases, investors from N are more likely to cooperate with Southern suppliers at arm's length instead of integrating them into firm boundaries if the contractibility of H 's activities, μ_{hS} , is low.

Proof. See Appendix H.

This Proposition argues that formal and informal institutions interact in their impact on the make-or-buy decision. When suppliers in S become more trustworthy, they are more concerned about the 'loss of reputation' in case of the break-down of a trust-based relationship. In terms of the model, the relative weight of the second term in $\pi_{MSF}^{DM} + \frac{\pi_{MSF}^s}{d_\ell}$ increases. In order to prevent supplier's deviation, H chooses the organizational form $F = I, O$ which makes the loss of reputation most costly to M . Using (22), it can be easily verified that M 's profits under outsourcing are lowest if μ_{hS} is low. Intuitively, if contractibility of headquarter services is low, H strongly underinvests in h . This underinvestment is largest and, therefore, M 's profits are lowest if H cooperates with a supplier at arm's length. Consequently, in high-trust countries outsourcing is more likely to be chosen as an organizational forms if product contractibility is low. This finding is well-aligned with the empirical evidence by Bernard et al. (2010a, b) presented in the introduction.

7 Concluding Comments

The aim of this theoretical paper is to contribute to the understanding of the interacting impact of formal and informal institutions on the international make-or-buy decision. I do so by introducing trust-based (relational) contracts into an otherwise standard model of North-South trade with partial contractibility. I show that formal and informal contracts may act both as complements and substitutes and discuss conditions under which explicit contracts crowd out the implicit ones. Given that relational contracts are useful in overcoming the inefficiencies associated with imperfect verifiability, this crowding-out has an adverse impact on consumers' welfare. I find that, while higher level of trust unambiguously increases a country's locational advantage, better contractibility ambiguously affects this country's attractiveness from the viewpoint of international investors. I further argue that the choice of organizational form (integration vs. outsourcing) plays a different role depending on whether a cooperation with a foreign contractor is founded on a trust basis or not. If a relational contract is not feasible, the headquarter chooses the organizational form so as to maximize her share of profits resulting from the ex post bargaining. In contrast, if a relational contract is self enforcing, the headquarter chooses the organizational form which is payoff-dominated from a contractor's view in order to minimize the latter's deviation incentives. In accordance with the recent empirical evidence presented in the introduction, I conclude that arm's length relationships are more likely to prevail in high-trust countries if product contractibility is low. This interaction between trust, formal institutions and the make-or-buy decision deserves further scrutiny in the future empirical work.

An interesting research agenda would be to relax the assumption that a country's level of trust is constant over time. For instance, one could assume that the level of trust is positively affected by the development of the legal system. Such a model would entail a richer set of predictions concerning the interaction between formal and informal institutions. On the one hand, better formal institutions may destroy current trust-based relationships, as in the present model. On the other hand, however, they can contribute to the emergence of new relational contract in the future. The repeated game described in this paper can serve as a starting point to study the evolution of trust.

References

- Anderson, J. (2004): Trade and Informal Institutions. In Choi, K., J. Hartigan (eds.), *Handbook of International Trade: Economic and Legal Analyses of Trade Policy and Institutions*, Vol. II, Blackwell Publishing.
- Antràs, P. (2003): Firms, Contracts and Trade Structure. *Quarterly Journal of Economics*, 118(4), 1375-1418.
- Antràs, P. (2011): Grossman-Hart (1986) Goes Global: Incomplete Contracts, Property Rights, and the International Organization of Production. *mimeo*.
- Antràs, P., E. Helpman (2004): Global Sourcing. *Journal of Political Economy*, 112, 552-580.
- Antràs, P., E. Helpman (2008): Contractual Frictions and Global Sourcing. In Helpman, E., D. Marin, T. Verdier (eds.), *The Organization of Firms in a Global Economy*, Harvard University Press.
- Antràs, P., E. Rossi-Hansberg (2009): Organizations and Trade. *Annual Review of Economics*, 1, 43-64.
- Antràs, P., R. Staiger (201): Offshoring and the Role of Trade Agreements. *American Economic Review*, forthcoming.
- Baker, G., R. Gibbons, K. Murphy (1994): Subjective performance measures in optimal incentive contracts. *Quarterly Journal of Economics* 109(4), 1125-1156.
- Baker, G., R. Gibbons, K. Murphy (2002): Relational Contracts and the Theory of the Firm. *Quarterly Journal of Economics*, 117(1), 39-84.
- Bernard, A., B. Jensen, S. Redding, P. Schott (2010a): Intrafirm Trade and Product Contractibility. *American Economic Review: Papers & Proceedings*, 100, 444-448.
- Bernard, A., B. Jensen, S. Redding, P. Schott (2010b): Intrafirm Trade and Product Contractibility (Long Version). *NBER Working Paper 15881*.
- Corcos, G. (2006): Globalization, Vertical Linkages, and ‘Relational Contracts’. *mimeo*.
- Costinot, A. (2009): On the Origins of Comparative Advantage. *Journal of International Economics*, 77, 255-264.

- Dixit, A. (2009): Governance Institutions and Economic Activity. *American Economic Review*, 99(1), 5-24.
- Dixit, A. (2011a): International Trade, Foreign Direct Investment, and Security. *Annual Review of Economics*, 3, 191-213.
- Dixit, A. (2011b): Governance, Trade, and Investment. *mimeo*.
- Guiso, L., P. Sapienza, L. Zingales (2009): Cultural Biases in Economic Exchange. *Quarterly Journal of Economics*, 124(3), 1095-1131.
- Guiso, L., P. Sapienza, L. Zingales (2010): Civic Capital as the Missing Link. *NBER Working Paper 15845*.
- Grossman, S., O. Hart (1986): The Costs and Benefits of Ownership: A Theory of Vertical and Lateral Integration. *Journal of Political Economy*, 94(4), 691-719.
- Grossman, G., E. Helpman (2005): Outsourcing in a Global Economy. *Review of Economic Studies*, 72(1), 135-159.
- James Jr., H. (2002): The Trust Paradox: A Survey of Economic Inquires Into the Nature of Trust and Trustworthiness. *Journal of Economic Behavior & Organization*, 47, 291-313.
- Johnson, S., J. McMillan, C. Woodruff (2002): Courts and Relational Contracts. *Journal of Law, Economics & Organization*, 18(1), 221-276.
- Halonen, M. (2002): Reputation and the Allocation of Ownership. *The Economic Journal*, 112, 539-558.
- Hart, O., J. Moore (1990): Property Rights and the Nature of the Firm. *Journal of Political Economy*, 98, 1119-1158.
- Helpman, E. (2006): Trade, FDI, and the Organization of Firms. *Journal of Economic Literature*, 44(3), 589-630.
- Kvaloy, O., T. Olsen (2009): Endogenous Verifiability and Relational Contracting. *American Economic Review*, 99(5), 2193-2208.
- Kukharsky, B., M. Pflüger (2010): Relational Contracts and the Economic Well-Being of Nations. *IZA Discussion Paper No. 5394*.
- Lehrer, E., A. Pauzner (1999): Repeated Games with Differential Time Preferences. *Econometrica*, 67(2), 393-412.

- Levchenko, A. (2007): Institutional Quality and International Trade. *Review of Economic Studies*, 74(3), 791-819.
- Mailath, G., L. Samuelson (2006): *Repeated Games and Reputations: Long-Run Relationships*. Oxford University Press, Oxford, UK.
- Macaulay, S. (1963): Non-Contractual Relationships in Business: A Preliminary Study. *American Sociological Review*, 28, 55-70.
- MacLeod, B. (2007): Reputations, Relationships, and Contract Enforcement. *Journal of Economic Literature*, 45, 595-628.
- McMillan, J., C. Woodruff (1999): Interfirm Relationships and Informal Credit in Vietnam. *Quarterly Journal of Economics*, 114, 1285-1320.
- North, D. (1990): *Institutions, Institutional Change and Economic Performance*. Cambridge University Press.
- Nunn, N. (2007): Relationship Specificity, Incomplete Contracts and the Pattern of Trade. *Quarterly Journal of Economics*, 122(2), 569-600.
- Schmidt, K., M. Schnitzer (1995): The Interaction of Explicit and Implicit Contracts. *Economics Letters*, 48, 193-199.
- Tabellini, G. (2008): Institutions and Culture. *Journal of the European Economic Association*, 6(2-3), 255-294.
- Tirole, J. (1999): Incomplete Contracts: Where Do We Stand? *Econometrica*, 67(4), 741-781.

Appendices

A Proof of Lemma 1

Bearing in mind that $\omega_j = \eta_j(1 - \mu_j)$, following results can be obtained from simple differentiation of equations in (10):

(i) Joint profits under spot contracting

$$\pi^s \equiv \pi_H^s + \pi_M^s = \left[\beta_h^{\frac{\alpha\omega_h}{1-\alpha}} \beta_m^{\frac{\alpha\omega_m}{1-\alpha}} (1 - \alpha[1 - \beta_h\omega_m - \beta_m\omega_h]) \right] (c_h^{-\alpha\eta_h} c_m^{-\alpha\eta_m})^{\frac{1}{1-\alpha}} 2AEQ_N^{-\frac{\alpha}{1-\alpha}}$$

are increasing in μ_j :

$$\frac{\partial \pi^s}{\partial \mu_j} = \left[-\frac{\ln \beta_j}{1-\alpha} - \frac{\beta_k}{1-\alpha(1-\beta_h\omega_m-\beta_m\omega_h)} \right] \alpha\eta_h \pi^s > 0.$$

This results due to the fact that $-\ln \beta_j > \beta_k$ for all $\beta_j \in (0, 1)$ and $\beta_k = 1 - \beta_j$, where $j, k = h, m; j \neq k$ and $(1 - \alpha) < (1 - \alpha(1 - \beta_h\omega_m - \beta_m\omega_h))$ for all possible parameter values.

(ii) The reaction of party H 's profits on the increase in μ_h is unambiguously positive:

$$\frac{\partial \pi_H^s}{\partial \mu_h} = -\frac{\ln(\beta_h)\alpha\eta_h}{1-\alpha} \pi_H^s > 0.$$

By changing subscripts it is readily shown that $\frac{\partial \pi_M^s}{\partial \mu_m} > 0$.

(iii) The reaction of party H 's profits on the increase in μ_m :

$$\frac{\partial \pi_H^s}{\partial \mu_m} = \left[-\frac{\ln(\beta_m)}{1-\alpha} - \frac{1}{1-\alpha(1-\eta_m(1-\mu_m))} \right] \alpha\eta_m \pi_H^s$$

is ambiguous since the terms in the squared brackets can be both positive and negative. Notice that $\frac{\partial \pi_H^s}{\partial \mu_m}$ is more likely to be positive the higher $\beta_h = 1 - \beta_m$, the lower μ_m and the higher η_m . Similarly, the sign of $\frac{\partial \pi_M^s}{\partial \mu_h}$ cannot be assigned unambiguously and it is more likely to be positive the higher is β_m , the lower μ_h and the higher η_h .

It immediately follows from the manipulation of the term in the squared brackets that $\frac{\partial \pi_H^s}{\partial \mu_m} < 0$ iff $\beta_m > e^{-\frac{1-\alpha}{1-\alpha(1-\omega_m)}}$, whereby $e^{-\frac{1-\alpha}{1-\alpha(1-\omega_m)}} \in (0, 1)$ for all $\alpha, \omega_m \in (0, 1)$.

B Proof of Lemma 2

Using (12), joint profits under relational contracting are given by

$$\pi^r \equiv \pi_H^r + \pi_M^r = (1 - \alpha) (c_h^{-\alpha\eta_h} c_m^{-\alpha\eta_m})^{\frac{1}{1-\alpha}} 2AEQ_N^{-\frac{\alpha}{1-\alpha}}.$$

Notice that these profits are independent from μ_j . By contrast, joint profits under spot contracting are increasing in μ_j , i.e. $\frac{\partial \pi^s}{\partial \mu_h} > 0$ und $\frac{\partial \pi^s}{\partial \mu_m} > 0$ (see Lemma 1). That is, if $\pi^r > \pi^s$ holds for $\mu_j = 1$, it holds a fortiori for all $\mu_j \in [0, 1)$. Substituting $\mu_h = \mu_m = 1$ in π^s and utilizing $\beta_m = 1 - \beta_h$ and $\eta_m = 1 - \eta_h$ therein yields the sufficient condition for $\pi^r > \pi^s$ to hold: $(1 - \alpha) > \beta_h^{\frac{\alpha \eta_h}{1-\alpha}} (1 - \beta_h)^{\frac{\alpha(1-\eta_h)}{1-\alpha}} (1 - \alpha[\beta_h \eta_h - (1 - \beta_h)(1 - \eta_h)])$. Rearrange this condition as

$$\psi_h(\eta_h) \equiv \beta_h^{\frac{\alpha \eta_h}{1-\alpha}} (1 - \beta_h)^{\frac{\alpha(1-\eta_h)}{1-\alpha}} (1 - \alpha[\beta_h \eta_h + (1 - \beta_h)(1 - \eta_h)]) + \alpha < 1.$$

It follows from simple differentiation of this function with respect to η_h that $\psi'(\eta_h) \geq 0$ iff

$$\gamma(\eta_h) \ln \left(\frac{1 - \beta_h}{\beta_h} \right) \leq (1 - \alpha)(1 - 2\beta_h), \quad (23)$$

where $\gamma(\eta_h) \equiv (1 - \alpha(\beta_h \eta_h + (1 - \beta_h)(1 - \eta_h))) > 0$ for all $\alpha, \beta_h, \eta_h \in (0, 1)$, and $\gamma'(\eta_h) \geq 0$ if $\beta_h \leq 1/2$. The following properties result from the inspection of inequality (23): (i) If $\beta_h < 1/2$, then $\psi'_h(\eta_h) < 0$, $\forall \eta_h, \alpha \in [0, 1]$; (ii) if $\beta_h > 1/2$, then $\psi'_h(\eta_h) > 0$, $\forall \eta_h, \alpha \in [0, 1]$; (iii) if $\beta_h = 1/2$, then $\psi'_h(\eta_h) = 0$, $\forall \eta_h, \alpha \in [0, 1]$. Using these properties, the sufficient conditions for $\psi_h(\eta_h) < 1$ to hold simplify to $\psi_h(0) < 1$ for $\beta_h \in (0, 1/2)$; $\psi_h(1) < 1$ for $\beta_h \in (1/2, 1)$, and $\psi_h(\eta_h) < 1$ for $\beta_h = 1/2$. It can be easily verified that these conditions hold for all $\alpha, \beta_h, \eta_h \in (0, 1)$. This implies $\psi_h < 1$ and completes the proof of Lemma 2.

C Proof of Lemma 3

Since $\pi^r > 0$ for all parameter values, Lemma 3 holds if and only if

$$\Omega(\alpha) \equiv \beta_h^{\frac{1}{1-\alpha\omega_h}} (1 - \alpha\omega_h) + \beta_m^{\frac{1}{1-\alpha\omega_m}} (1 - \alpha\omega_m) + \alpha(\omega_h + \omega_m) - 1 > 0.$$

It immediately follows for the corner solution, that $\Omega(0) = 0$. Taking the first order derivative of $\Omega(\alpha)$ with respect to α yields:

$$\frac{\partial \Omega}{\partial \alpha} = \omega_h \left(1 + \beta_h^{\frac{1}{1-\alpha\omega_h}} \left(\frac{\ln \beta_h}{1 - \alpha\omega_h} - 1 \right) \right) + \omega_m \left(1 + \beta_m^{\frac{1}{1-\alpha\omega_m}} \left(\frac{\ln \beta_m}{1 - \alpha\omega_m} - 1 \right) \right)$$

Moreover, $\frac{\partial^2 \Omega}{\partial \alpha^2} = \frac{\beta_h^{\frac{1}{1-\alpha\omega_h}} \omega_h^2 (\ln \beta_h)^2}{(1 - \alpha\omega_h)^3} + \frac{\beta_m^{\frac{1}{1-\alpha\omega_m}} \omega_m^2 (\ln \beta_m)^2}{(1 - \alpha\omega_m)^3} > 0$ implies $\frac{\partial \Omega}{\partial \alpha}|_{\alpha=0} < \frac{\partial \Omega}{\partial \alpha}$. Hence, the sufficient condition for $\frac{\partial \Omega}{\partial \alpha} > 0$ is $\frac{\partial \Omega}{\partial \alpha}|_{\alpha=0} > 0$. It can be easily verified that the latter condition holds for all possible parameter values. Since $\Omega(0) = 0$ and $\Omega'(\alpha) > 0$, it holds $\Omega(\alpha) > 0$ for all $\alpha, \eta_h, \beta_j \in (0, 1)$. This completes the proof of Lemma 3.

D Proof of Lemma 4

(i) H 's deviation profits decrease in μ_m :

$$\frac{\partial \pi_H^{DH}}{\partial \mu_m} = -\beta_h \alpha \eta_m (c_h^{-\alpha \eta_h} c_m^{-\alpha \eta_m})^{\frac{1}{1-\alpha}} 2AEQ_N^{-\frac{\alpha}{1-\alpha}} < 0.$$

By changing subscripts it is readily shown that $\frac{\partial \pi_M^{DM}}{\partial \mu_h} < 0$.

(ii) The reaction of party J 's deviation profits on the increase in μ_j :

$$\frac{\partial \pi_J^{DJ}}{\partial \mu_j} = -\alpha \eta_j \left[\frac{\beta_j^{\frac{1}{1-\alpha \omega_j}} \ln \beta_j}{1 - \alpha \omega_j} - \beta_j^{\frac{1}{1-\alpha \omega_j}} + \beta_j \right] (c_h^{-\alpha \eta_h} c_m^{-\alpha \eta_m})^{\frac{1}{1-\alpha}} 2AEQ_N^{-\frac{\alpha}{1-\alpha}}$$

is ambiguous since the term in the squared brackets can be both positive and negative. This term is more likely to be positive (i.e., $\partial \pi_J^{DJ} / \partial \mu_j$ is more likely to be negative) the higher ω_j , i.e., the lower μ_j and the higher η_j .

It immediately follows from the manipulation of the term in the squared brackets that $\frac{\partial \pi_M^{DM}}{\partial \mu_m} > 0$ if and only if $\beta_m^{\frac{\alpha \omega_m}{1-\alpha \omega_m}} (1 - \frac{\ln \beta_m}{1-\alpha \omega_m}) > 1$.

(iii) Joint deviation profits, $\pi^D \equiv \pi_H^{DH} + \pi_M^{DM}$ are given by

$$\pi^D = \left[\beta_h^{\frac{1}{1-\alpha \omega_h}} (1 - \alpha \omega_h) + \beta_m^{\frac{1}{1-\alpha \omega_m}} (1 - \alpha \omega_m) - \alpha (1 - (\omega_h + \omega_m)) \right] (c_h^{-\alpha \eta_h} c_m^{-\alpha \eta_m})^{\frac{1}{1-\alpha}} 2AEQ_N^{-\frac{\alpha}{1-\alpha}}$$

and are decreasing in μ_j

$$\frac{\partial \pi^D}{\partial \mu_j} = -\alpha \eta_h \left(\frac{\beta_j^{\frac{1}{1-\alpha \omega_j}} \ln \beta_j}{1 - \alpha \omega_j} - \beta_j^{\frac{1}{1-\alpha \omega_j}} + 1 \right) (c_h^{-\alpha \eta_h} c_m^{-\alpha \eta_m})^{\frac{1}{1-\alpha}} 2AEQ_N^{-\frac{\alpha}{1-\alpha}} < 0,$$

if and only if

$$LHS(\alpha) \equiv \beta_j^{\frac{1}{1-\alpha \omega_j}} \left(1 - \frac{\ln \beta_j}{1 - \alpha \omega_j} \right) < 1.$$

Differentiating LHS with respect to α and rearranging yields:

$$\frac{\partial LHS(\alpha)}{\partial \alpha} = -\frac{\beta_j^{\frac{1}{1-\alpha \omega_j}} \omega_j (\ln \beta_j)^2}{(1 - \alpha \omega_j)^2} < 0.$$

That is, if $LHS(\alpha) < 1$ holds for $\alpha = 0$, it holds a fortiori for all $\alpha \in (0, 1)$. In fact, $LHS(0) < 1$ for all $\beta_j \in (0, 1)$. This implies $\frac{\partial \pi^D}{\partial \mu_j} < 0$.

E Proof of Lemma 5

Using (10) and (12) in (17) immediately implies that $Q_N^r \geq Q_N^s$ if and only if $\pi_{H\ell}^r \geq \pi_{H\ell}^s$. Utilizing equilibrium bonus, $B_\ell = \frac{\pi_{M\ell}^s + d_\ell \pi_{M\ell}^{DM}}{1 + d_\ell} + C_{M\ell}^r$ from (15), this sufficient condition for $Q_N^r \geq Q_N^s$ can be rearranged as

$$\pi_\ell^r \geq \frac{\pi_\ell^s + d_\ell(\pi_{H\ell}^s + \pi_{M\ell}^{DM})}{1 + d_\ell}. \quad (24)$$

Notice that the upper bound of $\pi_{M\ell}^{DM}$ is given by the *ICC* from (15):

$$\pi_{M\ell}^{DM} \leq \frac{(\pi_\ell^r - \pi_\ell^s)}{d_\ell} + \pi_\ell^r - \pi_{H\ell}^{DM}$$

Substituting this upper bound for $\pi_{M\ell}^{DM}$ in (24) implies that the resulting sufficient condition holds if and only if $\pi_{H\ell}^s \leq \pi_{H\ell}^{DH}$. The latter inequality is indeed fulfilled under Assumption 2.

F Discussion of Proposition 3

This Appendix proves that $Q(\beta_{mS}) \equiv \beta_{mS}^{\frac{\alpha\omega_{mS}}{1-\alpha\omega_{mS}}} \left(1 - \frac{\ln \beta_{mS}}{1-\alpha\omega_{mS}}\right) > 1$ and $\beta_{mS} > e^{-\frac{1-\alpha}{1-\alpha(1-\omega_{mS})}}$ simultaneously hold if $\omega_{mS} < 3/4$. Notice first that the corner solution of $Q(\beta_{mS})$ for $\beta_{mS} = 1$ is $Q(1) = 1$ for all $\alpha, \omega_{mS} \in (0, 1)$. The first order derivative of $Q(\beta_{mS})$ with respect to β_{mS}

$$\begin{aligned} \frac{\partial Q(\beta_{mS})}{\partial \beta_{mS}} &= \frac{\alpha\omega_{mS}\beta_{mS}^{\frac{\alpha\omega_{mS}}{1-\alpha\omega_{mS}}-1}}{1-\alpha\omega_{mS}} \left(1 - \frac{\ln \beta_{mS}}{1-\alpha\omega_{mS}}\right) - \frac{\beta_{mS}^{\frac{\alpha\omega_{mS}}{1-\alpha\omega_{mS}}-1}}{1-\alpha\omega_{mS}} \\ &= -\frac{\beta_{mS}^{\frac{\alpha\omega_{mS}}{1-\alpha\omega_{mS}}-1}}{(1-\alpha\omega_{mS})^2} [\alpha\omega_{mS} \ln \beta_{mS} + (1-\alpha\omega_{mS})^2] \end{aligned}$$

is negative if and only if $T(\beta_{mS}) \equiv [\alpha\omega_{mS} \ln \beta_{mS} + (1-\alpha\omega_{mS})^2] > 0$. Notice that $T(\beta_{mS})$ is increasing in β_{mS} . That is, if $T(\beta_{mS}) > 0$ holds for the lowest β_{mS}^{min} , it holds a fortiori for all $\beta_{mS} \in (\beta_{mS}^{min}, 1)$. By substituting $\beta_{mS} = e^{-\frac{1-\alpha}{1-\alpha(1-\omega_{mS})}}$ in $T(\beta_{mS})$, it can be easily verified that the resulting expression is greater than zero for all $\alpha \in (0, 1)$ iff $\omega_{mS} < 3/4$. The latter requirement is thus the necessary condition for $\frac{\partial Q(\beta_{mS})}{\partial \beta_{mS}} < 0$. Combining this result with $Q(\beta_{mS} = 1) = 1$ implies Lemma 5.

G Proof of Proposition 4

Consider first the slope of $\Theta_{H\ell}^s(\eta_h)$. Simple differentiation of (19) with respect to η_h yields

$$\frac{\partial \Theta_{H\ell}^s}{\partial \eta_h} = \frac{\alpha}{1-\alpha} \Theta_{H\ell}^s ((1-\mu_{h\ell}) [\ln \beta_{h\ell I} - \ln \beta_{h\ell O}] + (1-\mu_{m\ell}) [\ln \beta_{m\ell O} - \ln \beta_{m\ell I}]) > 0,$$

whereby the sign result from the fact that expressions in squared brackets are greater than zero under Assumption 3.

Consider next the corner solutions of $\Theta_{H\ell}^s(\eta_h)$. If $\eta_h = 1$, spot integration strictly dominates spot outsourcing, since $\Theta_{H\ell}^s(1) = (\beta_{h\ell I}/\beta_{h\ell O})^{\frac{1-\alpha\mu_{h\ell}}{1-\alpha}} > 1$ under Assumption 3. For the other extreme value, $\eta_h = 0$, however, the sign of

$$\Theta_{H\ell}^s(0) = \frac{\beta_{h\ell I}}{\beta_{h\ell O}} \left(\frac{1-\beta_{h\ell I}}{1-\beta_{h\ell O}} \right)^{\frac{\alpha(1-\mu_{m\ell})}{1-\alpha}}$$

is ambiguous. Notice that the sign of the first order derivative of this expression wrt $\beta_{h\ell I}$

$$\frac{\partial \Theta_{H\ell}^s(0)}{\partial \beta_{h\ell I}} = \frac{[1-\alpha-\beta_{h\ell I}(1-\alpha\mu_{m\ell})]}{\beta_{h\ell O}(1-\beta_{h\ell I})(1-\alpha)} \left(\frac{1-\beta_{h\ell I}}{1-\beta_{h\ell O}} \right)^{\frac{\alpha(1-\mu_{m\ell})}{1-\alpha}}$$

depends on the sign of the term in the squared brackets. If this term is negative (i.e. $\beta_{h\ell I}$ is sufficiently high and $\mu_{m\ell}$ sufficiently low), $\Theta_{H\ell}^s(0)$ is decreasing in $\beta_{h\ell I}$. That is, if $\Theta_{H\ell}^s(0) \leq 1$ for the lowest possible $\beta_{h\ell I} = \underline{\beta}_{h\ell I}$, it holds $\Theta_{H\ell}^s(0) < 1$ for all $\beta_{h\ell I} > \underline{\beta}_{h\ell I}$. Recall from Assumption 3 that $\underline{\beta}_{h\ell I} = \beta_{h\ell O}$. It immediately follows that $\Theta_{H\ell}^s(0) = 1$ for $\beta_{h\ell I} = \beta_{h\ell O}$. Hence, $\Theta_{H\ell}^s(0) < 1$ for all $\beta_{h\ell I} > \beta_{h\ell O}$. Yet, if the term in squared brackets is positive (i.e. $\beta_{h\ell I}$ is sufficiently low and $\mu_{m\ell}$ sufficiently high), $\Theta_{H\ell}^s(0) > 1$ for all $\beta_{h\ell I} > \beta_{h\ell O}$.

Bearing in mind Assumption 3, a simple differentiation of (19) wrt $\mu_{m\ell}$ and $\mu_{h\ell}$ implies:

$$\frac{\partial \Theta_{H\ell}^s}{\partial \mu_{m\ell}} = \frac{\alpha\eta_m}{1-\alpha} \Theta_{H\ell}^s (\ln \beta_{m\ell O} - \ln \beta_{m\ell I}) > 0 \quad \text{and} \quad \frac{\partial \Theta_{H\ell}^s}{\partial \mu_{h\ell}} = \frac{\alpha\eta_h}{1-\alpha} \Theta_{H\ell}^s (\ln \beta_{h\ell O} - \ln \beta_{h\ell I}) < 0.$$

H Proof of Proposition 6

It follows from simple differentiation of (20) with respect to d_ℓ that $\frac{\partial \Theta_{M\ell}^r}{\partial d_\ell} > 0$ if and only if

$$\pi_{M\ell O}^{DM} \pi_{M\ell I}^s - \pi_{M\ell I}^{DM} \pi_{M\ell O}^s > 0. \quad (25)$$

Plugging (10) and (14) in this expression yields:

$$\begin{aligned}
Z \equiv & \beta_{m\ell O} \left[\beta_{m\ell O}^{\frac{\alpha\omega_{m\ell}}{1-\alpha\omega_{m\ell}}} (1 - \alpha\omega_{m\ell}) - \alpha(1 - (\omega_{h\ell} + \omega_{m\ell})) \right] \beta_{m\ell I} (\beta_{h\ell I}^{\alpha\omega_{h\ell}} \beta_{m\ell I}^{\alpha\omega_{m\ell}})^{\frac{1}{1-\alpha}} (1 - \alpha(1 - \omega_{h\ell})) \\
& - \beta_{m\ell I} \left[\beta_{m\ell I}^{\frac{\alpha\omega_{m\ell}}{1-\alpha\omega_{m\ell}}} (1 - \alpha\omega_{m\ell}) - \alpha(1 - (\omega_{h\ell} + \omega_{m\ell})) \right] \beta_{m\ell O} (\beta_{h\ell O}^{\alpha\omega_{h\ell}} \beta_{m\ell O}^{\alpha\omega_{m\ell}})^{\frac{1}{1-\alpha}} (1 - \alpha(1 - \omega_{h\ell})) > 0.
\end{aligned}$$

Bearing in mind that expressions in the squared brackets are positive under Assumption 1, $Z > 0$ is readily proven if

$$\begin{aligned}
Z_1 \equiv & \beta_{m\ell O} \left[\beta_{m\ell O}^{\frac{\alpha\omega_{m\ell}}{1-\alpha\omega_{m\ell}}} (1 - \alpha\omega_{m\ell}) - \alpha(1 - (\omega_{h\ell} + \omega_{m\ell})) \right] \beta_{m\ell I} (1 - \alpha(1 - \omega_{h\ell})) \\
& - \beta_{m\ell I} \left[\beta_{m\ell I}^{\frac{\alpha\omega_{m\ell}}{1-\alpha\omega_{m\ell}}} (1 - \alpha\omega_{m\ell}) - \alpha(1 - (\omega_{h\ell} + \omega_{m\ell})) \right] \beta_{m\ell O} (1 - \alpha(1 - \omega_{h\ell})) > 0
\end{aligned}$$

and $Z_2 \equiv (\beta_{h\ell I}^{\alpha\omega_{h\ell}} \beta_{m\ell I}^{\alpha\omega_{m\ell}})^{\frac{1}{1-\alpha}} - (\beta_{h\ell O}^{\alpha\omega_{h\ell}} \beta_{m\ell O}^{\alpha\omega_{m\ell}})^{\frac{1}{1-\alpha}} > 0$ simultaneously hold.

Since $\beta_{m\ell O} > \beta_{m\ell I}$ due to Assumption 3, $Z_1 > 0$ for all possible parameter values. Yet, $Z_2 > 0$ holds if and only if

$$Z_3 \equiv \left(\frac{\beta_{h\ell I}}{\beta_{h\ell O}} \right)^{\omega_{h\ell}} \left(\frac{1 - \beta_{h\ell I}}{1 - \beta_{h\ell O}} \right)^{\omega_{m\ell}} > 1.$$

Simple differentiation of Z_3 with respect to $\mu_{h\ell}$ yields $\frac{\partial Z_3}{\partial \mu_{h\ell}} = -\eta_h \ln \left(\frac{\beta_{h\ell I}}{\beta_{h\ell O}} \right) Z_3 < 0$. That is, Z_3 is more likely to be larger than one and, thereby, equation (25) is more likely to be positive if $\mu_{h\ell}$ is low.