

Alexeeva-Talebi, Victoria; Böhringer, Christoph; Löschel, Andreas; Voigt, Sebastian

Working Paper

The value-added of sectoral disaggregation: Implications on competitive consequences of climate change policies

ZEW Discussion Papers, No. 12-069

Provided in Cooperation with:

ZEW - Leibniz Centre for European Economic Research

Suggested Citation: Alexeeva-Talebi, Victoria; Böhringer, Christoph; Löschel, Andreas; Voigt, Sebastian (2012) : The value-added of sectoral disaggregation: Implications on competitive consequences of climate change policies, ZEW Discussion Papers, No. 12-069, Zentrum für Europäische Wirtschaftsforschung (ZEW), Mannheim, <https://nbn-resolving.de/urn:nbn:de:bsz:180-madoc-326210>

This Version is available at:

<https://hdl.handle.net/10419/66781>

Standard-Nutzungsbedingungen:

Die Dokumente auf EconStor dürfen zu eigenen wissenschaftlichen Zwecken und zum Privatgebrauch gespeichert und kopiert werden.

Sie dürfen die Dokumente nicht für öffentliche oder kommerzielle Zwecke vervielfältigen, öffentlich ausstellen, öffentlich zugänglich machen, vertreiben oder anderweitig nutzen.

Sofern die Verfasser die Dokumente unter Open-Content-Lizenzen (insbesondere CC-Lizenzen) zur Verfügung gestellt haben sollten, gelten abweichend von diesen Nutzungsbedingungen die in der dort genannten Lizenz gewährten Nutzungsrechte.

Terms of use:

Documents in EconStor may be saved and copied for your personal and scholarly purposes.

You are not to copy documents for public or commercial purposes, to exhibit the documents publicly, to make them publicly available on the internet, or to distribute or otherwise use the documents in public.

If the documents have been made available under an Open Content Licence (especially Creative Commons Licences), you may exercise further usage rights as specified in the indicated licence.

Discussion Paper No. 12-069

**The Value-Added of Sectoral
Disaggregation:
Implications on Competitive
Consequences of Climate Change Policies**

Victoria Alexeeva-Talebi, Christoph Böhringer,
Andreas Löschel, and Sebastian Voigt

ZEW

Zentrum für Europäische
Wirtschaftsforschung GmbH

Centre for European
Economic Research

Discussion Paper No. 12-069

**The Value-Added of Sectoral
Disaggregation:
Implications on Competitive
Consequences of Climate Change Policies**

Victoria Alexeeva-Talebi, Christoph Böhringer,
Andreas Löschel, and Sebastian Voigt

Download this ZEW Discussion Paper from our ftp server:

<http://ftp.zew.de/pub/zew-docs/dp/dp12069.pdf>

Die Discussion Papers dienen einer möglichst schnellen Verbreitung von
neueren Forschungsarbeiten des ZEW. Die Beiträge liegen in alleiniger Verantwortung
der Autoren und stellen nicht notwendigerweise die Meinung des ZEW dar.

Discussion Papers are intended to make results of ZEW research promptly available to other
economists in order to encourage discussion and suggestions for revisions. The authors are solely
responsible for the contents which do not necessarily represent the opinion of the ZEW.

Non-technical Summary

In the current discussion on policy measures to alleviate competitive disadvantages of unilateral climate policies, border measures are discussed as one possible instrument. The assessment of the economic impacts of border measures is often carried out with the help of multi-sector, multi-region computable general equilibrium (CGE) models and depends crucially on empirical data and their quality, in particular if policy makers are to be supported in their concrete decisions. However, these models frequently rely on global economic databases which are, with respect to their sectoral coverage, in many cases too broad to account for specific climate change policies. For instance, border measures may have adverse impacts on energy-intensive and trade-exposed sectors subject to the risk of carbon leakage. The GTAP 7.1 database to which the CGE model PACE (Policy Analysis based on Computable Equilibrium) is calibrated treats many of these industries as part of larger aggregate sectors and might thus miss important information on the heterogeneity of these sectors. In this paper, we use the PACE model to investigate the potential merits of the disaggregation of selected economic sectors. We elaborate on the availability of data resources and methodological issues and make use of a harmonized dataset of supply and use tables with a high sectoral resolution to split the sub-sectors “Cement, lime and plaster”, “Aluminium products” and “Manufacturing of iron and steel” out of their respective aggregate GTAP sectors. Drawing on the example of border tax measures, we analyze the impacts of disaggregation on sub-sectoral and macroeconomic indicators. Against the background of potential unobserved heterogeneity at the sub-sectoral level, our main objective is to detect how sensitive CGE simulation results are in terms of changes in the parameterization of disaggregated GTAP sectors. Therefore, we perform sensitivity analyses that involve variations in trade elasticities, energy intensities and technology assumptions. First, we find that a sectoral classification which is too aggregate neglects important insights about sub-sectoral implications. This shows the merits of sectoral disaggregation. Second, regarding the sensitivity analysis, we observe that tremendous deviations in the impact of border measures emerge from variations in Armington elasticities and the structure of the production functions. Third, the effects of sectoral disaggregation are not as pronounced for macroeconomic indicators and leakage as for sub-sectoral indicators. Hence, if we are merely interested in macroeconomic impacts, the use of databases at a higher sectoral aggregation level is sufficient.

Das Wichtigste in Kürze

In der aktuellen Diskussion über Maßnahmen zur Minderung von Wettbewerbsnachteilen durch unilaterale klimapolitische Eingriffe werden derzeit auch zunehmend Umweltzölle (Border Tax Measures) als ein mögliches Politikinstrument diskutiert. Die Beurteilung der ökonomischen Auswirkungen von Umweltzöllen erfolgt häufig im Rahmen von multiregionalen, multisektoralen rechenbaren allgemeinen Gleichgewichtsmodellen (CGE-Modelle) und hängt in entscheidendem Maße von den ihnen zu Grunde liegenden Daten und ihrer Qualität ab, insbesondere wenn Politiker in ihren konkreten Entscheidungen unterstützt werden sollen. CGE-Modelle beruhen jedoch zumeist auf globalen ökonomischen Datenbanken, die oftmals zu wenige sektorale Details enthalten, um spezifische Klimapolitiken zu berücksichtigen. Beispielsweise können Umweltzölle nachteilige Auswirkungen auf energieintensive und handelsorientierte Sektoren haben, die dem Risiko der Auslagerung von Teilen der emissionsintensiven Branchen (Carbon Leakage) ausgesetzt sind. Die Datenbank GTAP 7.1, die als Grundlage des CGE-Modells PACE (Policy Analysis based on Computable Equilibrium) dient, behandelt viele dieser Industrien als Teil größerer aggregierter Sektoren und könnte deshalb wichtige Informationen über die Heterogenität solcher Sektoren außer Acht lassen. In diesem Aufsatz verwenden wir das PACE-Modell, um potentielle Vorzüge der Disaggregation ausgewählter Wirtschaftssektoren zu untersuchen. Wir erläutern die Verfügbarkeit entsprechender Datenquellen und methodische Fragestellungen und verwenden einen regional harmonisierten Datensatz, der aus Aufkommens- und Verwendungstabellen mit einer hohen sektoralen Auflösung besteht, um die Sektoren „Zement, Kalk und Gips“, „Aluminiumprodukte“ und „Herstellung von Eisen und Stahl“ aus ihren jeweiligen aggregierten GTAP-Sektoren herauszulösen. Am Beispiel von Umweltzöllen analysieren wir die Auswirkungen dieser Disaggregation auf subsektorale und makroökonomische Indikatoren. Vor dem Hintergrund potentiell unbeobachteter Heterogenität auf der subsektoralen Ebene ist es unser Hauptanliegen zu ermitteln, wie sensibel die Ergebnisse der CGE-Simulationen auf Änderungen in der Parametrisierung der disaggregierten GTAP-Sektoren reagieren. Aus diesem Grund führen wir Sensitivitätsanalysen durch, die Variationen in Handelselastizitäten, Energieintensitäten und Technologieannahmen erlauben. Unsere Resultate implizieren, dass durch eine zu breite sektorale Gliederung wichtige Einblicke über subsektorale Effekte verloren gehen können, was auf die Vorzüge der sektoralen Disaggregation hinweist. Bezüglich der Sensitivitätsanalyse zeigt unsere Studie, dass es große Schwankungen geben kann, wenn Armingtonelastizitäten und die Struktur der Produktionsfunktionen variiert werden. Die Auswirkungen der Disaggregation auf makroökonomische Indikatoren und Carbon Leakage sind jedoch im Vergleich zu subsektoralen Effekten weniger ausgeprägt. Folglich ist die Verwendung von Datenbanken mit einem höheren Aggregationsniveau ausreichend, wenn man lediglich an der Untersuchung makroökonomischer Effekte interessiert ist.

The Value-Added of Sectoral Disaggregation: Implications on Competitive Consequences of Climate Change Policies

Victoria Alexeeva-Talebi^a, Christoph Böhringer^b, Andreas Löschel^c
and Sebastian Voigt^d

^aCentre for European Economic Research (ZEW), L 7, 1, D-68161 Mannheim, Germany; Email: alexeeva-talebi@zew.de, Phone: +49 621 1235-214, Fax: +49 621 1235-226

^bUniversity of Oldenburg, Department of Economics, D-26111 Oldenburg, Germany; Email: christoph.boehringer@uni-oldenburg.de

^cCentre for European Economic Research (ZEW), L 7, 1, D-68161 Mannheim, Germany; University of Heidelberg, Institute for Economics, Bergheimer Str. 58, D-69115 Heidelberg, Germany; Email: loeschel@zew.de

^dCentre for European Economic Research (ZEW), L 7, 1, D-68161 Mannheim, Germany; Email: voigt@zew.de

Abstract. Global impact assessment of unilateral climate policies is commonly based on multi-sector, multi-region computable general equilibrium (CGE) models that are calibrated to consistent accounts of production, consumption, and bilateral trade flows. However, global economic databases such as GTAP treat energy-intensive and trade-exposed industries rather in aggregate, thereby missing potentially important details on the heterogeneity of these sectors. In this paper, we elaborate on the availability of data resources and methodological issues in disaggregating energy-intensive and trade-exposed sectors that receive larger attention in the public policy debate on unilateral emission regulation: non-ferrous metals, iron and steel and non-metallic minerals. Our sensitivity analysis revolves around three types of unobserved heterogeneity at the sub-sectoral level: trade elasticities, energy consumption and technology specifications. Drawing on the example of border tax adjustments, we find that for all given technology specifications and variation in energy shares, the biggest differences emerge from variations in Armington elasticities. Even moderate changes in Armington elasticities can alter the magnitude and the sign of the effects at the sectoral level. The implications of sub-sectoral disaggregation are not as pronounced for macroeconomic indicators and leakage as for sectoral indicators.

Keywords: Sectoral disaggregation, emissions trading, border adjustment, competitiveness, carbon leakage

JEL Classification: D58, H21, H22, Q48

1. Introduction

In a world with different levels of ambitions in climate actions, unilateral climate policies with stringent carbon commitments, such as the EU Emissions Trading Scheme (ETS), have given rise to multiple concerns, including the potentially adverse impacts on competitiveness of European enterprises, in particular in energy-intensive and trade-exposed (EITE) sectors, that may hamper global environmental cost-effectiveness. One main argument put forward against the European leadership is that nations with stringent climate policies will put domestic energy-intensive industries at a disadvantage relative to competitors in countries with a lower level of ambitions. Heavy industry – mainly advocated by cement, steel and aluminum producing sectors – argued that the new European climate change legislation, first and foremost the further development of the EU ETS, would force them to move factories and jobs out of the EU's borders, leading to a 'leakage' of carbon emissions. Such concerns have been particularly extensive in Germany, the biggest player in the EU ETS (EurActiv, 2009).

The European policy makers followed up this line of arguments by recognizing that some forms of remedy shall be put in place as a part of the EU climate change policy. Directive 2009/29/EC on the revision of the EU ETS in Phase III up to 2020 included some provisions for limiting carbon leakage in EITE sectors, most importantly through the continuation of free allowance allocation (EU, 2009a). However, the Directive also allowed, albeit cautiously, for some forms of carbon motivated border tax adjustments (BTAs) to support certain EITE industries in the event of carbon leakage. In the wake of the failed Copenhagen negotiations in December 2009, the EU reinforced the possibility to apply trade-based measures as an effective option to address carbon leakage (EU, 2010). Obviously, BTAs are strongly supported by representatives of the EITE sectors. Nevertheless, they can also be justified as a second best complement to uniform pricing of domestic greenhouse gas emissions in the unilaterally acting region in the absence of a multilateral agreement covering all major emitters (Tamiotti et al., 2009). Therefore, the debate on trade-based anti-leakage measures in Europe has been echoed internationally, for example in the United States where the American Clean Energy and Security Act of 2009 (Waxman-Markey-Bill) included provisions on border tariffs, but also in Australia, New Zealand and Canada. However, border tariffs generate additional distortions that have to be traded off against the potential gains from leakage reduction.

The assessment of cost-effectiveness of border tariffs depends crucially on empirical data and their quality in order to support politicians in decision making. Over the last few years, the potential of BTAs to address competitiveness and environmental concerns has been addressed in a number of academic publications (Mathiesen and Maestad, 2004, Babiker and Rutherford, 2005, Peterson and Schleich, 2007, Alexeeva-Talebi et al., 2008, Alexeeva-Talebi et al., 2010, Demailly and Quirion, 2008, Monjon and Quirion, 2010). Several of these papers analyze the consequences of carbon-motivated trade measures based on multi-sector, multi-region computable general equilibrium (CGE) models that are calibrated to consistent accounts of production, consumption, and bilateral trade flows. However, the sector-specific implications for energy-intensive and trade-exposed industries which may play an important role from a political economy perspective are quite sensitive to the underlying databases that characterize the market situation of these industries. Global economic databases such as GTAP (Badri and Walmsley, 2008) which serves as the main dataset for many of these

models often treat these industries rather in aggregate, thereby missing potentially significant details on the heterogeneity of these sectors. Using a partial-equilibrium framework, Monjon and Quirion (2010) sharply criticized that the nomenclature generally used in CGE models is not detailed enough. The high level of aggregation may bias the assessment of carbon leakage risk and the offsetting potential of carbon-motivated trade measures. For viable policy conclusions it is therefore important to understand how sensitive CGE simulation results are with respect to changes in sectoral disaggregation and the parameterization of emerging sub-sectors.

Against this background, our main objective is to analyze the importance of heterogeneity of selected energy-intensive and trade-exposed sectors for the attractiveness of border tariffs. Therefore, sufficient sector-specific details must be included which are generally not available in global economic datasets used for the impact assessment of climate policies. In this paper, we discuss potentially important dimensions of sector heterogeneity as well as possible biases and sources of errors and examine how they affect the relative merits of border tariffs in comparison to emission pricing without additional policy instruments.

Using a unique new dataset from the EXIOPOL database (EXIOPOL, 2011), we first elaborate on methodological issues in disaggregating energy-intensive and trade-exposed sectors within the GTAP database. The major advantage of this dataset called Exiobase (www.exiobase.eu) is that it is a completely harmonized system of supply and use tables for 129 sectors and 43 countries, thus ensuring that the disaggregation exercise relies on a single sourced and hence equal basis. However, even with an improved disaggregation of energy-intensive and trade-exposed industries, the model-based analysis hinges on several critical assumptions. Drawing on the example of border tax adjustments, we investigate the potential for biased estimates due to aggregation and empirical misspecification due to unobserved heterogeneity at the level of the disaggregated sub-sectors.

Sectoral disaggregation allows applying for specific information on technologies and trade-responsiveness. Hence, the value added of sectoral disaggregation is not only demonstrated with respect to differences in cost shares but also with respect to a more differentiated representation of production technologies and international trade relationships. We revolve around three types of unobserved heterogeneity: We first refer to the aggregation bias arising when heterogeneity in behavioral parameter such as trade elasticities at the sub-sectoral levels is ignored. The applied literature repeatedly acknowledged the role of Armington elasticities as driving forces behind the modeled effects of policy experiments on trade patterns, welfare and other variables (Feenstra et al., 2011; Hillberry and Hummels, 2011). Most recently, it was argued that products at the higher level of sectoral disaggregation might be closer substitutes. Balistreri et al. (2010) pointed out, for instance, that for the oil and petroleum producing sector Armington elasticities can be rather high, exceeding the values commonly reported in the literature and adopted in simulation studies. Consequently, one would expect much less hysteresis in trade pattern. An obvious source of aggregation bias is therefore not to account for potentially prevailing heterogeneity related to trade adjustments at the sub-sectoral levels. In this paper we address this type of concerns relying on a number of assumptions for trade elasticities. This is due to missing empirical evidence for the sectors of interest. It is either related to a very narrowly selected range of industries at a highly disaggregated level but low regional resolution or it covers a wide range of industries at a lower level of sectoral disaggregation (Gallaway et al., 2003, Welsch, 2008).

Second, we analyze the role of technology heterogeneity across sectors for the robustness of our results and conclusions. A single production function at the sectoral level assumes common production technology across all sub-sectors facing the same factor prices. But an aggregate production function only offers an appropriate construct if the sectors do not display large technology heterogeneity. It was shown in the literature that if technology parameters differ across sectors, the aggregate production function (technology) cannot be of the (standard) Cobb-Douglas form (Stoker, 1993; Temple and Wößmann, 2006). Eberhardt and Teal (2012) generalize this finding and conclude that revealing differential technology parameters in sectoral production functions is potentially a serious challenge to treating production in form of an aggregated function. However, these concerns about aggregation biasness due to technology heterogeneity are largely ignored in the applied literature on climate policy. In this paper we adopt different assumptions on nesting structures of the production factors capital, labor, material and energy (Böhringer et al., 2009, Kemfert, 2002, Burniaux and Truong, 2002) to test for the robustness of sectoral disaggregation to alternative technology specifications.

We finally revolve around the sub-sectoral heterogeneity in energy and CO₂ intensities. At the sub-levels, these intensities can substantially differ across sectors as they increase (or decrease) because of variation in energy use, fossil fuel composition, substitution possibilities and production levels. Obviously, competitiveness and leakage effects could vary with energy and CO₂ intensity as some narrowly defined industries might be potentially more vulnerable because they are particularly energy-intensive (see e.g. Aldy and Pizer, 2011). But for the aggregation biasness, the heterogeneity in energy intensities at the sub-levels does also matter. We address this issue in this paper through the variation of reference values derived from the EXIOPOL database.

Our results show that the usage of new data, enriched with a detailed sequence of CO₂ and trade intensities at the sub-sectoral level, is a necessary but not a sufficient condition for a proper assessment of carbon price implications. We find that assumptions about the underlying technology specifications and trade elasticities matter most for sub-sectoral, sectoral and macroeconomic implications. For example, even a moderate variation in Armington elasticities can change the magnitude and the sign of the effects. In contrast, capturing the heterogeneity in energy and CO₂ intensities at the sub-sectoral level is less crucial for the aggregated sectoral and macroeconomic results, at least as long as the respective values at the upper level remain unchanged.

The remainder of this paper is organized as follows. Section 2 introduces the disaggregation techniques and the unique dataset we use for the envisaged analysis based on a multi-sector, multi-region computable general equilibrium (CGE) model. Drawing on the example of border tax adjustments, section 3 presents a quantitative impact assessment and a sensitivity analysis revolving around three types of unobserved heterogeneity at the level of the disaggregated sub-sectors. Section 4 summarizes our simulation results as well as the merits of sectoral disaggregation for the policy analysis and section 5 concludes.

2. Model structure and sectoral disaggregation: Data and issues

In order to track the value-added of sectoral disaggregation for the assessment of competitive and environmental consequences of climate change policies, we rely on PACE, an established multi-region, multi-sector computable general equilibrium (CGE) model of global trade

and energy use. Böhringer et al. (2009) provide a diagrammatic structure and explain the underlying assumptions about the substitution possibilities in the production process of fossil and non-fossil goods, consumer preferences, CO₂ accounting and the representation of trade links in the model. Bilateral trade is specified following the Armington approach of product heterogeneity, i.e. domestic and foreign goods are distinguished by origin (Armington, 1969). For the sake of compactness, we point the readers to this publication for more details.

The model is calibrated to the most recent consistent accounts of production, consumption, and bilateral trade flows for the base year 2004, subsequently referred to as GTAP 7.1 database (Badri and Walmsley, 2008). Elasticities in international trade are likewise based on empirical estimates reported in the GTAP 7.1 database. A detailed and consistent tracking of energy and trade flows within a multi-region setting is a pre-requisite for the assessment of the competitive consequences of climate change policies. Despite a rather comprehensive regional and sectoral coverage with 112 regions and 57 sectors, the GTAP 7.1 database does not provide sufficient sectoral detail about the energy-intensive industries. The GTAP sector “non-ferrous metals” (NFM), for instance, covers a broad range of metals such as zinc, copper and aluminum that are partially very different in their production processes.

At the sectoral level, the disaggregation of the GTAP 7.1 database is therefore essential in order to distinguish energy-intensive industries at the GTAP sub-level by CO₂ intensity, the degree of substitutability, price elasticities of output demand and the bilateral trade links. The costs of complying with emission constraints and the effects of anti-leakage measures are directly linked to their structural characteristics. In the exercise performed in this paper, we split three GTAP energy-intensive branches – non-ferrous metals, iron and steel and non-metallic minerals – that receive larger attention in the public policy debate on unilateral emission regulation. Table 1 describes the affiliation of NACE 1.1 sectors within the GTAP classification.¹

Albeit our disaggregation technique can be easily employed to cover a large number of sectors, in this paper we chose to extract the following sub-sectors from their respective aggregate GTAP sectors:

- Manufacture of cement, lime and plaster, and products thereof²
- Aluminium and aluminium products, and
- Manufacture of basic iron and steel and of ferro-alloys.

Prior to the revision of the EU ETS in the Phase III, representatives of cement, aluminium and steel producing companies claimed to be particularly exposed to the risk of carbon leakage and were qualified as vulnerable by the Commission’s Decision (EU, 2009b). Most of the discussions preceding the Commission’s conclusion centred on the assessment of these “classic sectors of industrialisation” (Dröge, 2011). It was mainly rooted in the role these branches played in terms of CO₂ emissions and the dependence on export activities for entrepreneurial success. For instance, the cement sector accounts for approximately 5% of global anthropogenic CO₂ emissions (Kim and Worrell, 2002a) and the iron and steel production even for

¹ NACE (Nomenclature statistique des activités économiques dans la Communauté européenne) is a detailed industrial classification scheme used in particular by the European statistical offices and is similar to but more detailed than ISIC (International Standard Industrial Classification).

² Throughout the remainder of this paper, we refer to this sector as cement, lime and plaster.

some 6 to 7% (Kim and Worrell, 2002b). Although the production of aluminium shows only a global share of approximately 0.2% (Sjardin, 2003), it has a relatively high share of about 1% of industrial trade³ and has shown openness to sectoral approaches which makes it interesting for our analysis. Last but not least, the respective organized industrial groups could extensively use detailed production, trade and energy data, although not making them publicly available⁴, and other resources to show the limitations in restructuring towards low-carbon production without sacrificing the international competitiveness.

Table 1: Sectors in the GTAP 7.1 database and corresponding NACE 1.1 sectors

GTAP sectors	Corresponding NACE 1.1 sectors	
Non-metallic minerals (NMM)	26.1	Manufacture of glass and glass products
	26.2	Manufacture of ceramic products
	26.3	Manufacture of ceramic tiles and flags
	26.4	Manufacture of bricks, tiles and construction products
	26.5	Manufacture of cement, lime and plaster
	26.6	Manufacture of articles of concrete, plaster and cement
	26.7	Cutting, shaping and finishing of ornamental and building stone
	26.8	Manufacture of other non-metallic mineral products
Non-ferrous metals (NFM)	27.41	Precious metal production
	27.42	Aluminium production
	27.43	Lead, zinc and tin production
	27.44	Copper production
	27.45	Other non-ferrous metal production
	27.53	Casting of light metals
	27.54	Casting of other non-ferrous metals
Iron and steel (I_S)	27.1	Manufacture of basic iron and steel and of ferro-alloys
	27.2	Manufacture of tubes
	27.3	Other first processing of iron and steel
	27.51	Casting of iron
	27.52	Casting of steel

Hence, the disaggregated model features important CO₂- and trade-intensive industries which are potentially most affected by carbon abatement policies: cement, lime and plaster (CEM) and other non-metallic minerals (ONMM) which form the GTAP sector non-metallic minerals (NMM); aluminium (ALU) and other non-ferrous metals (ONFM) which build the GTAP sector non-ferrous metals (NFM); manufacturing of iron and steel (ISM) and further processing of iron and steel (ISP) which compose the GTAP sector iron and steel (I_S). The energy goods acknowledged in the model are coal, crude oil, natural gas, refined oil products, and electricity. In the cement sector waste and biomass account for a significant share of thermal energy (see CSI, 2009) which is not included in our model. The remaining sectors

³ The aluminium shares are based on own calculations using EXIOPOL data.

⁴ An important exception is the data collection effort of the cement industry, published as “Getting the Numbers Right” (GNR) by the Cement Sustainability Initiative (CSI, 2009).

include chemical products, air, water and other transport as well as all other goods (Table 8 of the Appendix presents an overview on all regions and sectors of the model version used here).

Disaggregation procedure

Drawing on the example of the aluminium sector, Figure 1 depicts a simplified input output table and data requirements for the envisaged disaggregation exercise. Basically, the sectoral disaggregation implies the extraction of the sub-sector “aluminium” out of the aggregate sector “non-ferrous metals” by creating two new sectors “aluminium” (ALU) and “other non-ferrous metals” (ONFM).

As a primary data source for the GTAP disaggregation we used the EXIOPOL database – called Exiobase (www.exiobase.eu) – which yields supply and use tables for 129 sectors and 43 countries.⁵ So far CGE models have been based either on global databases such as GTAP or on national datasets. The former offer the advantage of being multilateral datasets but they are commonly too aggregated in terms of their sectoral coverage. In contrast, the latter frequently possess detailed sectoral resolution but those datasets are unilateral. Hence, there is no information on the cooperative advantage of industries across regions. However, this is one of our key issues in the paper. Therefore, we apply EXIOPOL data which is the best available compromise to date that accounts for both of these subjects.

The EXIOPOL database was created by using various sources of which the most important for our purposes will be outlined in the following. For the production data, Eurostat supply and use tables were consulted for EU countries (Eurostat, 2012), whereas for non-EU countries input-output tables from national statistical offices were applied. Furthermore, expert interviews with representatives from statistical offices were conducted. To construct import and export flows, information from Feenstra et al. (2005) was used. The authors harmonized data by the United Nations (UN Comtrade). Information on energy and emissions stems from databases provided by the International Energy Agency (IEA). To create detailed tables, balancing techniques that minimize entropy were employed.

The major advantage of using this dataset is that it is a completely harmonized system of supply and use tables, thus ensuring that the disaggregation exercise relies on a single sourced and hence equal basis. At the regional scale, all EU and larger EFTA member states (Norway and Switzerland) as well as all important non-EU countries are included, particularly the United States, Canada, Japan, Australia, the BRIC countries, South Korea, Mexico, Indonesia, Turkey, Taiwan and South Africa. As to the sectoral treatment, the EXIOPOL database covers significantly more energy-intensive industries as the GTAP database does: Table 2 provides details focusing on sectors addressed in our analysis. The base year of the EXIOPOL data is 2000 whereas GTAP 7.1 uses 2004 as its base year. Since we rely on shares of the sub-sectors, we assume that the economic structure remained constant in all regions between 2000 and 2004.

⁵ This database is the final product of the EXIOPOL (A New Environmental Accounting Framework Using Externality Data and Input Output Tools for Policy Analysis) project in the 6th Framework Programme of the European Commission under the project number 037033.

Figure 1: Simplified example of the data requirements for the sectoral disaggregation on the basis of an input output table

	Agricultural products	Coal	Oil	Gas	Electricity	Petroleum products	Non-ferrous metals		Further sectors	Private consumption	Investment	Exports	Total value of use
							Aluminium	Rest of Sector					
Agricultural products													
Coal													
Oil													
Gas													
Electricity													
Petroleum products													
Non-ferrous metals	Aluminium												
	Rest of Sector												
Further sectors													
Capital													
Labour													
Imports													
Total value of production													

Table 2: Selection of relevant sectors in the EXIOPOL database

No.	Sector
61	Glass and glass products
62	Ceramic goods
63	Bricks, tiles and construction products
64	Cement, lime and plaster
65	Other non-metallic mineral products
66	Basic iron and steel and ferro-alloys and products thereof
67	Precious metals
68	Aluminium and aluminium products
69	Lead, zinc and tin and products thereof
70	Copper products
71	Other non-ferrous metal products
72	Foundry work services

To perform the sectoral split we proceed data on production, imports, exports, intermediate and final consumption. In particular, we calculate the relative importance of sub-sectors within the aggregate sectors for all these variables. More specifically,

- shares for “cement, lime and plaster” are derived relating values of sector 64 (corresponds to NACE 26.5 and 26.6) to the sum of sectors 61 to 65,
- shares for “aluminium” are calculated relating the values for sector 68 (corresponds to NACE 27.42 and parts of 27.53) to the sum of sectors 67 to 71,
- for “manufacturing of iron and steel” we compute the ratio of sector 66 and the sum of sectors 66 and 72 but we have to use some additional data sources due to a still relatively high aggregation (see below for further details).

Our procedure is rather straightforward: For intermediate and final consumption as well as for export, we use the relevant columns of the use tables. For production and imports, we make use of the relevant rows in the supply tables.

As mentioned above, for the sector “manufacturing of iron and steel” the information provided in the EXIOPOL data is still too aggregated. Sector 66 of Table 2 covers the NACE sectors 27.1 to 27.3, while the sector of our interest is only sector 27.1 of the NACE classification. Therefore, we decided to complement the EXIOPOL database with some additional data sources. For the production and energy shares of the EU member states we use Eurostat Structural Business Statistics (Eurostat, 2011a), for non-EU countries we use UN Industrial Commodity Statistics (UN, 2011a). In order to calculate import and export shares, we draw on Eurostat External Trade data (Eurostat, 2011b) for EU member states and UN Comtrade data (UN, 2011b) for the remaining countries. Also for the other considered sectors, a more detailed database would be preferable, e.g. providing a sector for cement without lime and plaster. However, although we are aware of these caveats, the EXIOPOL dataset serves our purpose best since it is, to our knowledge, the only balanced dataset with such a broad regional coverage and sectoral detail. For all GTAP regions that are not part of the EXIOPOL database we use weighted averages of the existing regions to compute the relevant shares.⁶

Figure 2 demonstrates for all of our sectors to be disaggregated that the relative importance within their respective aggregate GTAP sectors varies significantly across the regions. The production share, for instance, takes values between less than 20 percent in the case of China and some 60 percent in the cases of Germany and Mexico for the “cement, lime and plaster” (CEM) sector within the aggregate sector “Non-metallic minerals”. Export and import exposure of the CEM sector also differs considerably around the globe. In India almost the whole trade volume in the sector “non-metallic minerals” takes place in the sub-sectors other than CEM. In contrast, in Germany almost 30 percent of imports and exports within the sector “non-metallic minerals” can be assigned to the cement, lime and plaster industry. The other two sectors show a similar regional diversity with production shares of the aluminium sector ranging from almost 0 percent in Japan to more than 50 percent in the United States within the “non-ferrous metals” aggregate sector. The production share of “iron and steel manufacturing” ranges between 30 and more than 80 percent. Also the trade shares show significant regional variations. Obviously, all these regional differences shall be taken into consideration when impact assessment is taking place.

⁶ The value of the respective parameters (production, consumption etc.) for each aggregate sector serves as the weight.

Figure 2: Overview of production, export and import shares for the disaggregated sectors within their respective GTAP sectors

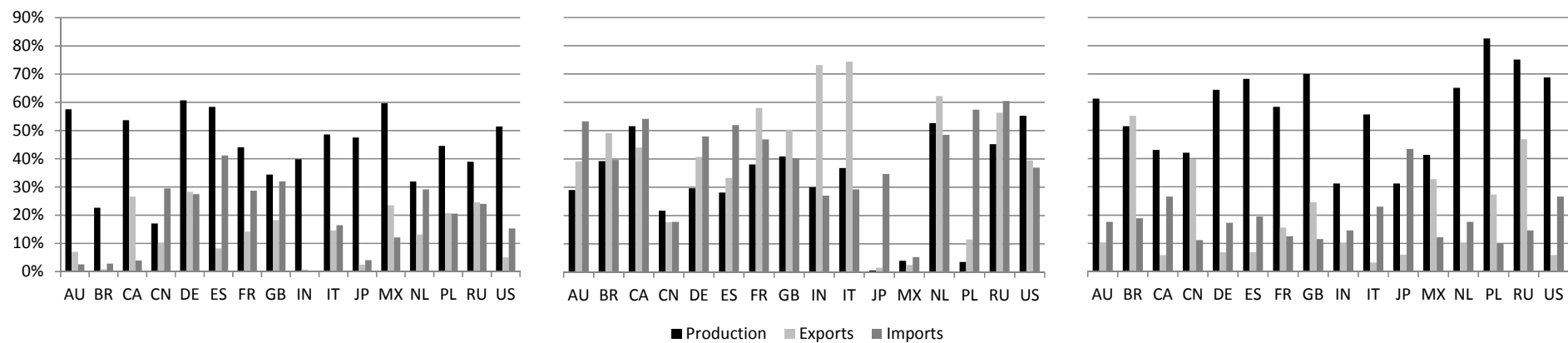

Cement, Lime and Plaster

Aluminium

Iron and Steel Manufacturing

The next step consists of applying the calculated shares to construct a new database. Numerous parameters of the GTAP database, such as various trade indicators at world and market prices, endowments of primary factors, the consumption of firms and households and savings, have to be modified according to the collected information on the sub-sectors. The most crucial part of this step is balancing the new dataset which is not a straightforward task. Since we use different shares for sectors and regions, it is obvious that the extended input output dataset is not automatically balanced. In particular, without further adjustments demand and supply of the various sectors may not be in equilibrium. Furthermore, the disaggregated trade flows may cause some excess demand or supply within the disaggregated sectors. Hence, it is necessary to use iterative procedures which eliminate these problems and simultaneously maintain as much information as possible from the additionally collected data. For this purpose we use SplitCom routines written by Mark Horridge (Horridge, 2008) which uses the shares obtained in the previous steps to split the respective sectors and to balance the extended dataset. In this way, an expanded and balanced GTAP database is generated, containing 60 sectors instead of 57. A drawback of the SplitCom routine is, however, that it cannot be applied to disaggregate relevant energy and emissions data of the GTAP database. We perform this step in a routine subsequent to the SplitCom disaggregation. In order to calculate the energy and emissions values of the disaggregated sectors we make use of domestic and imported intermediate inputs of each energy carrier within a sub-sector and an aggregate sector.

The result of the aforementioned steps can be represented as a set of input output tables, one for each model region, which constitute the underlying data source of the PACE model. Table 9 of the Appendix summarizes the columns and rows of the aggregated and disaggregated input output table for "EU27 and EFTA" in sectors of our major interest. For the purpose of the following simulation exercise other sectors of the GTAP database were aggregated. The details on all other sectors can be found in Tables 10 and 11 of the Appendix. Importantly, the sub-sectors cement, lime and plaster, aluminium, and iron and steel manufacturing have significantly higher emission values than their respective counterparts.⁷ This observation confirms our expectation about the prevailing sub-sectoral heterogeneity which might have a pronounced impact on the aggregation results, an issue we address in the next section.

Drawing on the example of the cement/lime/plaster sector, Table 3 presents a comparison between output data obtained after the disaggregation procedure and original data from various sources for the year 2004. The second row depicts total supply at market prices derived from the disaggregated GTAP dataset. The third row shows monetary data for some selected major economies. For the US, information from BEA (2012) was consulted (gross output) while for the European countries we use data from Eurostat (2011a) converted into US dollars (production value). For China and India, no such detailed data was available to the authors. Therefore, we computed ranges based on cement production in Mt taken from USGS (2006) and on price ranges provided by Walker (2006, Chart 4.1). Note that for China and India the production of lime and plaster as well as products of cement, lime and plaster are not included in contrast to the other countries due to the lack of appropriate secondary data. That is why there is a relatively large discrepancy with regard to physical cement pro-

⁷ It is important to mention that our model encompasses only direct CO₂ emissions from fuel combustions, i.e. we neglect process emissions.

duction shown in the fourth row. Furthermore, the share of actual cement production within the entire sector in the developed countries is quite low (between 10 and 20%). Despite this caveat, we observe a clear consistency between data derived from the disaggregation procedure and original data from other sources, in particular for the developed countries. Apart from the missing information on other components of the sector in China and India aside from cement, another reason for the differences between production in physical values and in monetary values is that cement prices are significantly lower in the emerging economies, especially in China, than in the developed countries.

Table 3: Comparison between GTAP data (after disaggregation with EXIOPOL data) and original data (2004)

	US	Germany	Italy	Spain	France	China	India
<i>GTAP after disaggregation in bn US\$</i>	60.588	24.512	27.892	17.291	17.266	71.343	4.945
<i>Original sources in bn US\$ (BEA, Eurostat, own calculations)</i>	53.978	19.465	20.623	17.871	15.244	21.280 - 42560	5.200 - 7.800
<i>Cement production in Mt (USGS, 2006)</i>	99	32	38	48	20	1,064	130

Source: BEA (2012), Eurostat (2011a), Walker (2006), own calculations

3. Impact assessment of EU climate policies and scenario definitions

In our numerical analysis we investigate the competitive and environmental consequences of EU climate policy focusing on two counterfactual scenarios, *reference* and *tariff*. Given the current bleak prospective for the Post-Kyoto agreement covering major emitting countries, we assume a unilateral response of the EU to the threat of climate change in 2020. Under the scenario *reference*, the EU reduces its CO₂ emissions in 2020 by 20% vs. the 2004 levels through a comprehensive cap-and-trade system covering all EU emission sources. This is a hypothetical policy scenario not reflecting the actual EU policy which features a 20% emissions reduction for six greenhouse gases in the sectors covered by the EU ETS compared to the 1990 emissions level.

The scenario *reference* serves as the benchmark for comparison with the *tariff* scenario that features likewise a unilateral emissions reduction target of 20% in the EU but additionally introduces carbon tariffs on non-carbon constrained EU trading partners and lowers down the costs of domestic exporters at the border. Offsetting measures apply to (five) energy-intensive and export-oriented sectors i.e. iron and steel (I_S), non-ferrous metals (NFM), chemicals (CRP), mineral industries (NMM) and refined oil (OIL). Within the GTAP sectors we intend to split, the border adjustments are also introduced at the sub-sectoral level. The EU importers face the European allowance price which is applied to the actual carbon content

of the respective energy-intensive industry producing abroad. The carbon content is based on direct fuel inputs and electricity. European industries subjecting to border adjustments are additionally assumed to receive carbon rebates for export activities, a policy option which amplifies the shifting of the abatement burden towards the non-covered segment of the economy (Alexeeva-Talebi et al., 2008). The rebate level is determined such that it equals the sector-specific value of CO₂ demand divided by the domestic production level.

In each scenario, we implement a carbon leakage compensation to keep the global environmental effectiveness constant: In addition to the reduction target of the coalition members, Europe in our case, the other regions are not allowed to exceed their benchmark emissions according to the BaU. Therefore, the “global target” of CO₂ emissions remains constant throughout all scenarios.

Against the background of potentially unobserved heterogeneity at the sub-sectoral level, our primary objective is to reveal how sensitive CGE simulation results concerning competitiveness impacts and carbon leakage are with respect to changes in the parameterization of disaggregated GTAP sectors. We revolve around three types of unobserved heterogeneity at the sub-sectoral level arising due to differences in trade elasticities, technology specification and energy intensities across sub-sectors. Our sensitivity analysis focuses on sub-sectoral effects, assesses the biasness of aggregation for GTAP sectors and evaluates macroeconomic implications of alternative parameterization schemes.

An obvious source of errors in sectoral impact assessment and an aggregation bias is not to account for potentially prevailing heterogeneity related to trade adjustments beyond the GTAP aggregation level. The first type of uncertainties we address in our sensitivity analysis is related to the choice of Armington elasticities which can exceed the values commonly reported in the literature. In principle, products at the higher level of sectoral disaggregation might be closer substitutes than products at the upper levels. But there is little empirical evidence for these sectors (Gallaway et al., 2003) and much skepticism about the correctness of estimates where they are available (Hillberry and Hummels, 2011). Hence, in this paper we address this type of concerns relying on a number of assumptions. We apply a wide range elasticity values to the disaggregated sub-sectors, i.e. cement, lime and plaster, iron and steel, and aluminium, and the respective remaining sub-sectors forming the GTAP sectors NMM, I_S and NFM. We are in particular interested in determining whether the implications at the sub-sectoral, sectoral and macro level change when high and low Armington elasticities are substituted for the reference GTAP estimates. For *low* we halve those GTAP Armington reference values which are applicable to NMM, I_S and NFM sectors; for *high* we double the respective values. For *asymmetric* we double the reference GTAP elasticities for CEM, ALU and ISM, but halve them for the remaining sub-sectors (ONMM, ONFM and ISP) forming the aggregated GTAP sectors. In this way, we account for potentially diverging trade elasticities among the sub-sectors.

The general literature on aggregation repeatedly addressed the issues of parametric aggregation of heterogeneous micro-production technologies (e.g. Biørn et al., 2006). Eberhardt and Teal (2012) concluded that revealing differential technology parameters in sectoral production functions is potentially a serious challenge to treating production in form of an aggregated function. In the context of climate change policy, Sathaye, (2007) pointed out that an aggregation bias can also arise when changes in mitigation options at the sub-sectoral levels over time are overlooked. But again, empirical evidence is missing on what technolog-

ical specifications (production functions) are appropriate for what type of energy-intensive industries and how they are likely to evolve over time. Simulation studies typically apply three major archetypes of nesting structures to all non-fossil-fuel production sectors. Apart from a technology specification with an energy composite trading off with an aggregate of capital, labour and material (KLM-E form) as in Kemfert (2002), we additionally focus in this paper on two further technology specifications referred to as a KL-E form in Böhringer et al. (2009) and as a KE-L form in Burniaux and Truong (2002). In our simulation analysis, we apply these types of nesting structures to all sectors and sub-sectors to study the adjustment mechanisms and take the respective aggregated substitution elasticities from Okagawa and Ban (2008). Simplified nesting trees for the technology specifications are presented in Figure 5 of the Appendix.

The third type of uncertainties at the sub-sectoral level which is considered in this paper refers to the energy share of disaggregated energy-intensive industries within the aggregate GTAP sectors. Energy shares can substantially differ across sectors as they increase or decrease because of variation in both energy use and production levels. Obviously, sub-sectoral competitiveness effects will vary not only with the available mitigation options, but also with energy shares as some narrowly defined industries might be potentially more vulnerable because they are particularly energy-intensive. We address these concerns revolving around the reference energy shares derived from the EXIOPOL database. Our *low* energy scenario reflects decreased energy consumption in the sectors producing cement/lime/plaster, iron and steel, and aluminium by 20% in comparison to the reference values calculated with the EXIOPOL database. The *high* energy scenario is designed to consider the economic and environmental implications of disaggregation if energy consumption in the sectors of interest is increased by 20% relative to what the EXIOPOL database suggests.⁸

To sum up, our sensitivity analysis to assess the implications of potentially unobserved heterogeneity at the sub-sectoral level refers to the following parameters and specifications:

- Armington elasticities of EITE sectors – ARM_REF (GTAP reference values), ARM_LOW (0.5*reference elasticity), ARM_HIGH (2*reference elasticity), asymmetric (CEM, ALU and ISM: 2*reference elasticity; ONMM, ONFM and ISP: 0.5*reference elasticity);
- Assumptions on technology – TECH_1 (KLM-E form, Kemfert, 2002), TECH_2 (KL-E form, Böhringer et al., 2009, Bosetti et al., 2006), TECH_3 (KE-L form, Burniaux and Truong, 2002);
- Energy shares in disaggregated sectors – E_REF (reference values for energy consumption from the data sources described above), E_LOW (20% less energy consumption for CEM, ALU and ISM) and E_HIGH (20% more energy consumption for CEM, ALU and ISM).

4. Results

In this section, we present our results along the following lines: We first focus on the interpretation of simulation results generated with an aggregated GTAP database, then we centre on model runs based on the disaggregated GTAP database and finally we investigate the merits of sectoral disaggregation.

⁸ In some cases the energy share of the newly created sectors is high and would exceed 1 if increased by 20%. Thus, in these cases the energy share of the CEM, ALU and ISM sub-sectors is 1 in the *high* scenarios.

All results, except for leakage rates, are reported as a percentage change of the considered indicator compared to a reference situation in 2020 – the Business-as-Usual (BaU) – where there is no unilateral policy put in place. We report the simulation results for the EU only, attributing this restriction for the sake of compactness to the large number of scenarios and issues we discuss.

Simulation results with the aggregated GTAP database

In our core simulation runs with the aggregated GTAP 7.1 database, we apply the two counterfactual scenarios *reference* and *tariff* as described above, revolved around different assumptions on nesting structures at the sectoral level and retained to reference Armington elasticities. The macroeconomic and sectoral (aggregated) results are driven by the discrepancy between the production possibility frontiers and elasticities of substitution associated with different nesting structures.

The adjustments at the macro-level, reported in Table 4, are particularly pronounced if energy is traded off at the top level with an aggregate of capital, labour and material (TECH_1, KLM_E form). The marginal abatement cost (CO₂ prices) and macroeconomic implications directly follow as a function of the imposed emission constraints and substitution possibilities. If we adopt a unilateral emission reduction target of 20% (the *reference* scenario), the welfare in the EU drops significantly – at a CO₂ price of about 70 US\$ – by some 0.5% compared to the BaU. Welfare costs are reported as Hicksian equivalent variation (HEV) in income. As to the implications for the GTAP sectors we particularly focus on, output declines associated with the carbon constraints can vary considerably (Table 5): In the *reference* scenario, the output losses range from some 1.4% for the NMM sector (“non-metallic minerals”) to roughly 4.6% for the NFM sector (“non-ferrous metals”).⁹ The adjustments in export activities are even more pronounced. Our results further confirm a basic economic reasoning that unilateral policies will result in carbon leakage. The carbon leakage rate is conventionally defined in our assessment as the change in foreign emissions relative to the share of the domestic emissions reductions. The carbon leakage rate in the *reference* scenario amounts to about 15%.¹⁰ The introduction of carbon motivated border measures (the *tariff* scenario) attenuates the leakage of emissions to some 10%. The gains from reduced leakage are reflected in decreasing CO₂ prices (63 US\$) and a slight improvement in welfare of European citizens compared to a unilateral commitment. Both findings which are in contrast to the results of several other studies, e.g. Winchester et al. (2011), Monjon and Quirion (2011a, 2011b), are a consequence of the leakage compensation implemented in our simulation exercises.¹¹ Due to the constant value of global emissions, the reduction burden of the EU is relaxed through the introduction of border measures. Hence, CO₂ prices decline as a result of the tariff introduction. This price decline and the smaller reduction burden also increase the welfare levels in the EU compared to the *reference* case, albeit only to a very small extent. Without this leakage compensation, welfare losses would be lower in general and

⁹ The sectoral output measure used in this paper is gross output.

¹⁰ Carbon leakage may occur via two channels. First, through the competitiveness channel, production is relocated to regions without emission reduction targets and hence parts of the emission reductions in the EU are offset by increasing emissions in these regions. Second, fossil fuel prices decrease because the policy induces reduced demand for fossil fuels. Consequently, fossil fuel demand in other regions rises resulting in increasing emission levels. Since the fuel price is flexible in our scenarios, both channels are included.

¹¹ Winchester et al. (2011) and Monjon and Quirion (2011a, 2011b) do not impose leakage compensations.

would increase in the *tariff* scenario (e.g. -0.345% in the *reference* scenario and -0.380% in the *tariff* scenario for the TECH_1 specification). CO₂ prices would be considerably lower without the leakage compensation as no global target exists, and the prices would increase slightly when border measures are introduced (for example, for the TECH_1 specification the price is 49.34 US\$ in the *reference* scenario and 50.32 US\$ in the *tariff* scenario). The latter finding is due to the fact that border measures reduce the substitution possibilities between foreign and domestic products and thus abatement efforts within the coalition have to increase. These results are qualitatively in line with other studies.

Furthermore, we find that all sectors benefit from the introduction of import taxes and export rebates by expanding output and export levels. The NFM sector which was affected most by unilateral policies is even able to slightly increase its production levels compared to the BaU.

Table 4: Macro level impacts for the EU in 2020, aggregated dataset

Indicator	Scenario	TECH_1	TECH_2	TECH_3
<i>Welfare (% chg vs. BaU)</i>	<i>reference</i>	-0.506	-0.262	-0.285
	<i>tariff</i>	-0.487	-0.254	-0.276
<i>CO₂ price (US\$)</i>	<i>reference</i>	70.05	50.08	46.35
	<i>tariff</i>	63.22	44.52	41.66
<i>Emissions (% chg vs. BaU)¹²</i>	<i>reference</i>	-23.42	-23.31	-23.27
	<i>tariff</i>	-22.16	-22.16	-22.18
<i>Leakage rate (%)</i>	<i>reference</i>	14.78	14.35	14.22
	<i>tariff</i>	9.93	9.90	9.99

Note: We use reference Armington elasticities for these calculations

Let us now consider the impacts of imposing alternative technology specifications to which we have referred above as to TECH_2 (KL-E form) and TECH_3 (KE-L form). First and foremost, there exist some significant differences in impacts between these specifications and the one we have discussed previously. However, the differences are attributed not only to the nesting structure itself but also to the values of substitution elasticities which characterize the respective production functions.¹³ Böhringer et al. (2008) address these issues using a concept of a price elasticity of demand which is in a rather complex way composed of substitution elasticities. The differences in the composition of the production function between TECH_1 on the one hand and TECH_2 and TECH_3 on the other hand is much more pronounced than between TECH_2 and TECH_3, because in the former specification energy is substituted with the KLM aggregate in the top nest whereas in both TECH_2 and TECH_3 energy is substituted in lower nests. Therefore, the impacts are more similar between the latter two, but these differ, to some extent considerably, from the impacts using TECH_1. Consequently, a significant modification of the technology structure in addition to the modi-

¹² The results are displayed in percentage reductions compared to the BaU. Therefore, emissions reductions are higher than 20% since BaU emissions in 2020 are higher than those in 2004. Furthermore, the leakage compensation also explains why the emission reduction results vary along the different specifications. As mentioned previously, due to the constant global target emission reduction burdens of the EU vary along different parameter specifications and scenarios.

¹³ The values of the applied substitution elasticities are presented in Figure 5 and Table 12 of the Appendix for all three specifications and the sectors under consideration. More specifically, for TECH_1 we use GTAP elasticities, while Okagawa and Ban (2008) deliver elasticity estimates for TECH_2 and TECH_3.

fication of substitution elasticities has strong effects on the price elasticities of demand and hence on overall results.

The CO₂ prices fall in the *reference* scenario to some 50 US\$ in TECH_2 and to roughly 46 US\$ in TECH_3. The welfare losses are almost halved with approximately 0.3% in both cases in comparison to the TECH_1 specification. At the sectoral level, lower CO₂ prices are translated into smaller output and export losses, confirming our expectation that the choice of the technology specification has an impact on the magnitude of the simulated results. For instance, for the NFM sector the export losses under the *reference* scenario are reduced from some 5.4% (TECH_1) to roughly 4.0% (TECH_3). The leakage rate also decreases, but only to a small extent. If we turn finally to the *tariff* scenario which introduces border measures, our simulation runs underline once again the importance of the ‘correct’ technology specification for the magnitude of the simulated effects.

Table 5: Sectoral output and export effects in 2020 (% vs. BaU), aggregated dataset

Sectors	TECH_1		TECH_2		TECH_3	
Scen	Output	Export	Output	Export	Output	Export
<i>NMM</i>						
<i>ref</i>	-1.36	-2.53	-1.47	-2.17	-1.44	-2.11
<i>tariff</i>	0.69	1.10	0.06	0.49	0.00	0.41
<i>NFM</i>						
<i>ref</i>	-4.60	-5.39	-3.56	-3.97	-3.45	-3.85
<i>tariff</i>	1.19	0.85	0.77	0.79	0.67	0.69
<i>I_S</i>						
<i>ref</i>	-2.55	-3.60	-2.29	-3.27	-2.34	-3.27
<i>tariff</i>	0.39	0.69	0.02	0.29	-0.16	0.10

Note: We use reference Armington elasticities for these calculations

Simulation results with a disaggregated GTAP database: Sub-sectoral effects

One of the main objectives of our simulation analysis is to explore the sub-sectoral heterogeneity beyond the GTAP aggregation level and to understand how sensitive the obtained CGE simulation results are with respect to changes in sectoral disaggregation and the parameterization of emerging sub-sectors with respect to trade elasticities, technology specifications and energy shares of the sub-sectors.

We proceed with the interpretation of the results of the sub-sectors emerging from the GTAP sectors “non-metallic minerals” (NMM), “non-ferrous metals” (NFM) and “iron and steel” (I_S). Figures 3a to 3f depict the respective output effects for the EU revolving around alternative technology specifications, Armington elasticities and energy intensities. Importantly, the induced adjustments in the sub-industries “cement, lime and plaster” (CEM) and “other non-metallic minerals” (ONMM) in Figures 3a and 3b differ tremendously not only in magnitude but partially also in sign, an insight which would be missed without our disaggregation efforts.

A policy option aiming at an introduction of a 20% unilateral emission reduction target with and without border measures has ambiguous impacts for the CEM sector. They strongly depend on the model specification and parameterization. Under the *reference* scenario, the range of output losses varies from some 0.2% to more than 1% (Figure 3a). Thereby, for a given technology specification the output losses increase with rising Armington elasticities as

the relatively less costly goods from abroad are more easily substituted with domestic products. Another important driver is the technology choice: For a given level of Armington elasticity, clear differences arise between TECH_1, on the one hand, and TECH_2 and TECH_3 on the other. In contrast, the variation in energy shares is of minor importance, albeit a higher energy consumption in the CEM sector (relative to the reference case) induces higher output losses and vice versa.

Figure 3b focuses on “other non-metallic minerals” (ONMM), a second industry forming the GTAP sector “non-metallic minerals” (NMM). Under the *reference* scenario, the output losses in the ONMM sector are much more dramatic than in the CEM sector reaching up to 4% for high Armington elasticity values. Hence, the flexibility in substitution decreases with the size of industry leading to more pronounced production adjustments. Alike, competitiveness effects in the ONMM sector vary with the energy share: As we keep the respective energy consumption at the upper GTAP level constant, its variation at the sub-level has inverse effects in the ONMM sector compared to the CEM sector. To put it differently, higher energy shares of the ONMM sector (relative to reference case) consistently imply stronger output losses (here, the *E_LOW* scenario implies higher energy shares of the ONMM sector since *LOW* refers to the energy share of the CEM sector within the GTAP sector NMM).

The effects regarding the aluminium sector (ALU) and “other non-ferrous metals” (ONFM), both forming the GTAP sector “non-ferrous metals” (NFM), are less pronounced (Figures 3c and 3d). The results for both sub-sectors are less different than those of the NMM sub-sectors above, however with slightly higher output losses in the ONFM sector. Output losses vary between approximately 1.8% and 7.7% in the aluminium sub-sector and between 2.0% and 9.8% in the ONFM sector under the *reference* scenarios. This is mainly due to higher trade intensities of the aluminium sector in contrast to the CEM sector. Since cement is a product which is rarely traded in general and also with respect to the share within the aggregate GTAP sector NMM (see Figure 2), a fact that is mainly based on the high transportation costs of the product, it is difficult to relocate its production processes to non-abating regions as a consequence of unilateral emission reduction targets. Therefore, output losses are smaller in relative terms in the CEM sector than in the ONMM sector. Aluminium on the other hand has a higher trade share within the aggregate NFM sector and the relocation of production is more likely to occur. Hence, despite similar – or even lower – production shares of aluminium and cement, lime and plaster within their respective aggregate sectors, the output effects in the two sub-sectors of NFM differ less than those of the NMM sub-sectors.

The results in Figures 3e and 3f refer to the sub-sectors manufacturing (ISM) and further processing (ISP) of the GTAP sector “iron and steel” (I_S). The difference of the output effects between both sub-sectors is more pronounced, similar to the NMM sub-sectors. For instance, under the *reference* scenarios, output losses range between 0.7% and 3.3% in the ISM sub-sector and between 2.0% and 7.8% in the ISP sub-sector. Along similar lines to those of the NMM sub-sectors, this can be attributed to a low trade share of the ISM sub-sector within I_S. This applies in particular to the export share of the major economies (see Figure 2). Thus, production in ISM is hardly relocated to non-abating regions inducing lower output losses in the ISM than in the ISP sub-sector.

Throughout Figures 3c to 3f, we observe a behaviour of the results with respect to their sensitivity to energy shares, Armington elasticities and technology specifications which is similar

to the NMM sub-sectors. The variation in energy shares is less important and the effects show the same pattern as in the CEM and ONMM sub-sectors: Rising energy shares induce stronger effects since climate policies affect the sub-sectors more severely if they consume more (fossil) energy. Also for variations of the Armington elasticities the pattern is the same. Using a similar reasoning as outlined above, higher Armington elasticities cause stronger effects. Furthermore, as in the case of the CEM and ONMM sub-sectors, a relatively clear difference can be identified between technology specification TECH_1 on the one hand and TECH_2 and TECH_3 on the other hand. The issues of the 'correct' technology specification become even more pressing when we turn to the *tariff* scenario where the production level adjustments relative to the BaU levels can differ even in sign, in particular when looking at the output effects of the CEM sub-sector. As mentioned previously, the modification of the nesting structure results in a change of the price elasticities of demand. In combination with border measures which increase the export-import ratio, the different price elasticities of demand may induce contrary output effects. The sensitivity of the effects to the technology specification which we observe throughout many of our results can hence become more obvious with the introduction of border measures. Note however that in the CEM sector where we observe the largest differences output effects are relatively small.

Figures 4a and 4b assess the aggregation bias for the GTAP sectors NMM, NFM and I_S when the disaggregated GTAP data set is employed. In all panels of Figures 4a and 4b the left bar shows the results for the *reference* scenario, whereas the right bar shows the results for the *tariff* scenario. The differences at the level of GTAP sectors are consistent in sign for the different sub-sectoral specifications.¹⁴ Nevertheless, the magnitude of the impacts strongly depends on the sub-sectoral specification of trade elasticities and energy shares and can differ a lot from what we call the *AGG_REF** situation - the latter is based on the GTAP specification of the sectors NMM, NFM and I_S with an aggregated dataset. The highest variation in the outcomes arises for the different Armington elasticities whereas the smallest is found for the variation in energy shares. Although this outcome certainly depends also on the variation range of the energy shares chosen by the authors, it is a result we find throughout all of the three pairs of sub-sectors considered.

Finally, we find that the use of a disaggregated GTAP dataset is not resulting in any significant variation of macro variable impacts (Tables 6 and 7). Due to an increased flexibility, CO₂ prices, welfare impacts and leakage rates are slightly smaller but the differences are not pronounced. This statement also holds true if we revolve around alternative model specifications and parameterization with respect to both Armington elasticities and energy intensity. Nevertheless, the three sectors have relatively small output and emission shares in comparison to the entire economy, so the results on the macro level might be more noticeable if several other sectors were disaggregated.

The value-added of sectoral disaggregation

What have we learned from the above analysis? First, there are pronounced differences in magnitude and sign when we analyze the results at the sub-sectoral level. The outcomes presented in Figures 3a to 3f confirm this for the sub-sectors forming the non-metallic minerals, non-ferrous metals and iron and steel GTAP sectors. Therefore, as an answer to the

¹⁴ When considering the disaggregated dataset, the figures report aggregated values, i.e. the simulations were run with the disaggregated sectors and reaggregated afterwards for the purpose of comparability.

questions outlined in the introductory section, the merits of sectoral disaggregation are clearly visible on the sub-sectoral level. Second, for all given technology specifications, considerable differences arise if Armington elasticities change. Even a moderate variation in the values can alter the magnitude and the sign of the effects. Hence, the empirical estimation of the Armington elasticities at the sub-sectoral level is crucial for the consistent assessment of sub-sectoral impacts and aggregation bias. Third, in addition to the empirically robust estimation of the Armington elasticities, the correct technology specification is central. Various variables are very sensitive to the choice of the nesting structures. This applies in particular to macro level indicators but in many cases also to the sub-sectoral level. As outlined previously, restructuring the production function may have strong effects on the price elasticities of demand and can thus result in heterogeneous impacts. This issue is also a potential field for further research. CGE models may obtain fruitful technology information on the sub-sectoral level by including engineering-based approaches. For instance, for the steel sector Schumacher and Sands (2007) replace the CES production function with engineering cost descriptions of the steel technologies. Li et al. (2000) use the technology bundle approach to model the Taiwanese electricity sector. Bauer et al. (2008) link macroeconomic growth model with energy system models using two approaches. The first includes the complete technological information from the energy system model in to the macroeconomic model whereas in the second approach only energy supply functions generated by the energy system model are integrated. Those types of including bottom-up information can help to overcome the problem of finding the appropriate nesting structures though this is a complex task if all energy-intensive industries of interest shall be described.

5. Conclusions

In this paper we explore the role of sectoral disaggregation in evaluating unilateral climate policies that may affect economic sectors unequally. In particular, the competitiveness of several energy-intensive industries can potentially decrease resulting in carbon leakage. To assess the impacts of such policies in a computable general equilibrium framework, the underlying databases are usually too aggregated to represent the relevant sectors in a suitable manner. Against this background, our paper investigates the potential biases and sources of errors arising when aggregate data at the sectoral level instead of more disaggregated data at the sub-sectoral level is adopted in a simulation analysis. The disaggregation exercise performed in this study builds thereby upon a unique database which yields production, bilateral trade and energy consumption data for a large number of energy-intensive industries in a high regional resolution.

Drawing on the example of border tax adjustments, we investigate the potential for biased estimates due to aggregation and empirical misspecification due to unobserved heterogeneity at the level of the disaggregated sub-sectors.

In addition, we carry out a sensitivity analysis by varying modelling assumptions such as the technology specifications or Armington elasticities to check for the robustness of our results.

The simulation results can be summarized as follows. First, the effects on various indicators of the sub-sectors within one GTAP sector can differ to a high extent. Hence, if we are interested in sector-specific conclusions of policies, a sectoral classification which is too broad may neglect important insights about the impacts on various sub-industries. For simulations with the disaggregated database, the magnitudes of the impacts are more pronounced than

for simulations with the aggregated database. However, the differences at the level of GTAP sectors (non-metallic minerals, iron and steel, and non-ferrous metals) are consistent in sign for the different sub-sectoral specifications. In addition, the effects of disaggregation are not as pronounced for macroeconomic indicators and leakage as for sectoral indicators. Hence, if we are only interested in macroeconomic or leakage impacts, the value-added of the sectoral disaggregation is limited.

With respect to the analysis of unobserved heterogeneity, the implications at the level of sub-sectors are consistent across variations in the energy split between the sub-sectors. For all given technology specifications and variation in energy shares, the biggest differences emerge if we vary the Armington elasticities. Even a moderate variation in Armington elasticities can change the magnitude and the sign of the effects. Hence, the empirical estimations of Armington elasticities at the sub-sectoral level are urgently needed.

In addition to the results regarding sectoral disaggregation, an interesting outcome of our analysis is that there are to some extent enormous variations in the results across the different technology specifications. In particular, this holds for CO₂ prices and welfare effects on the macro level but partially also for several effects on the sub-sectoral level. These differences turn out higher for the specification of the nesting structure where the energy composite is substituted with the non-energy composite in the top-level of the CES production function than for the two specifications where energy is traded off either with the capital-labour composite or with capital directly. Results for the latter specifications are similar in sign and magnitude. Thus, when assessing the impact of climate policies on sectoral and macroeconomic indicators, the implementation of the 'correct' technology specification is crucial.

The model analysis does not only underline the need for increased efforts in the sectoral disaggregation of relevant sub-sectors, but also for an improved empirical foundation of substitution and trade elasticities at the sub-sectoral level if the aim of the analyses is to study competitiveness implications of climate change policies on energy-intensive and trade exposed industries and related carbon leakage. If one is merely interested in the macro level, results using the conventional broad level of aggregation are meaningful.

Figure 3a: Sub-sectoral output effects – EU’s cement, lime and plaster sector (cem)

(a) Reference scenario

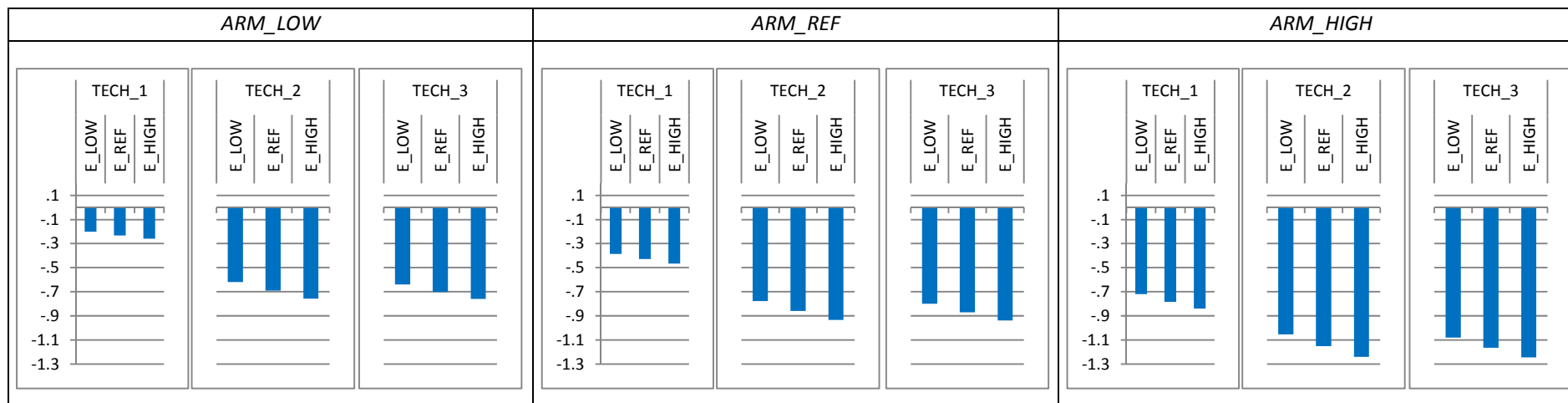

(b) Tariff scenario

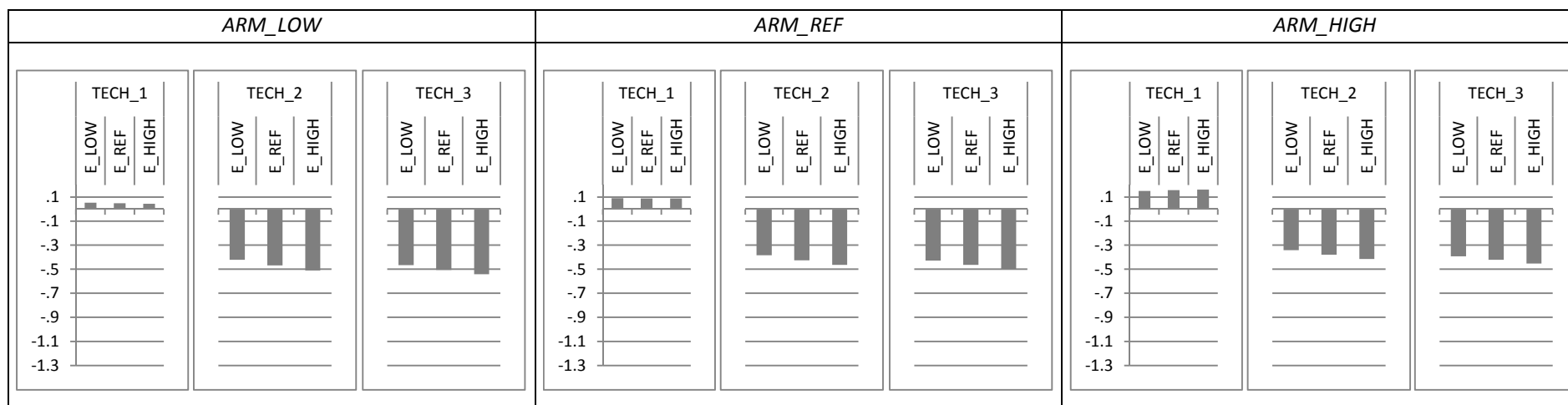
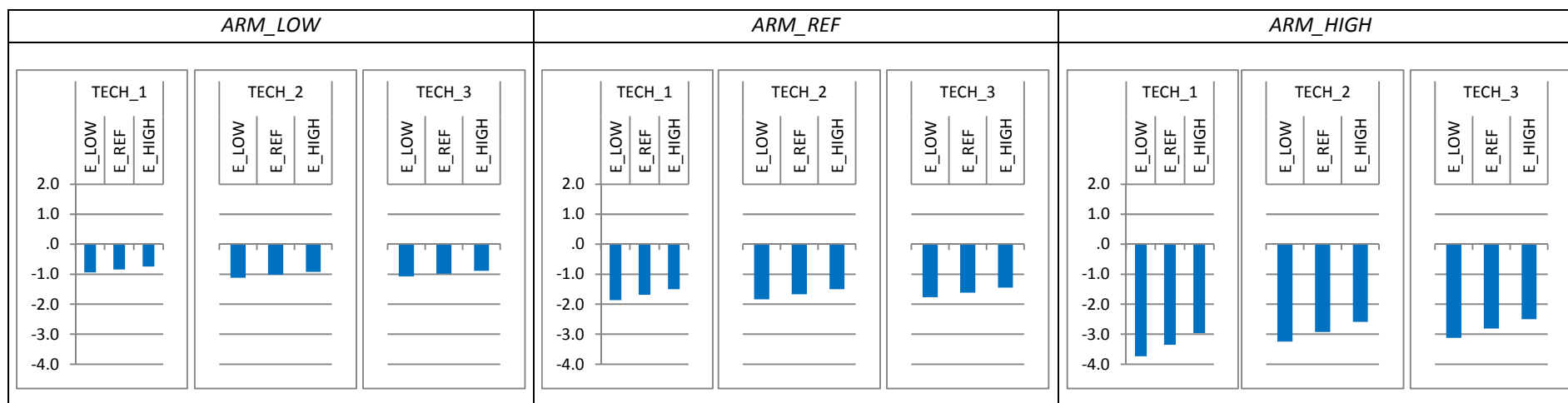

Figure 3b: Sub-sectoral output effects – EU’s other non-metallic minerals (onmm)

(a) Reference scenario



(b) Tariff scenario

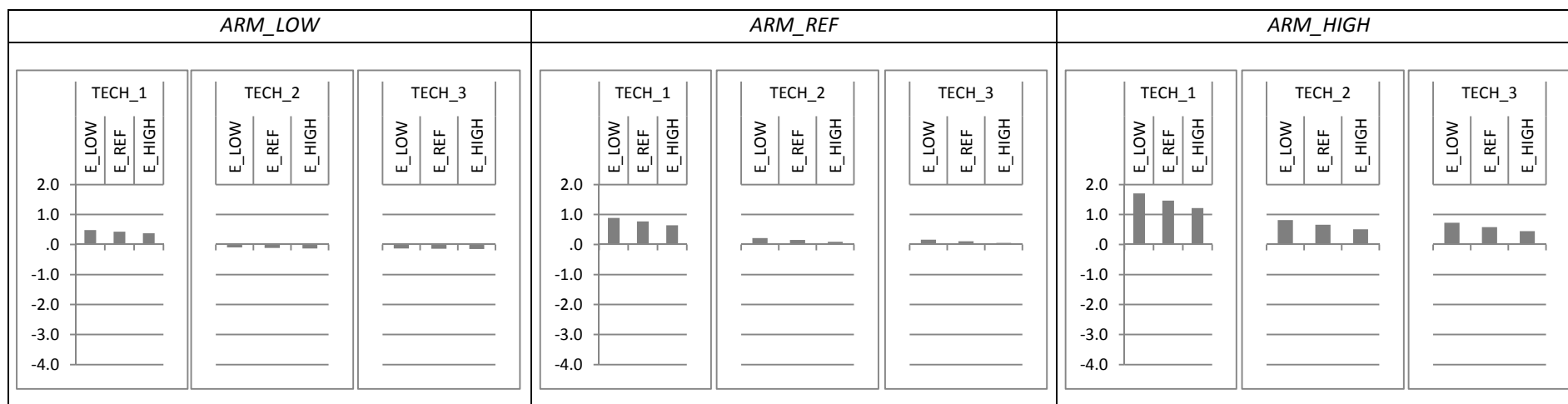
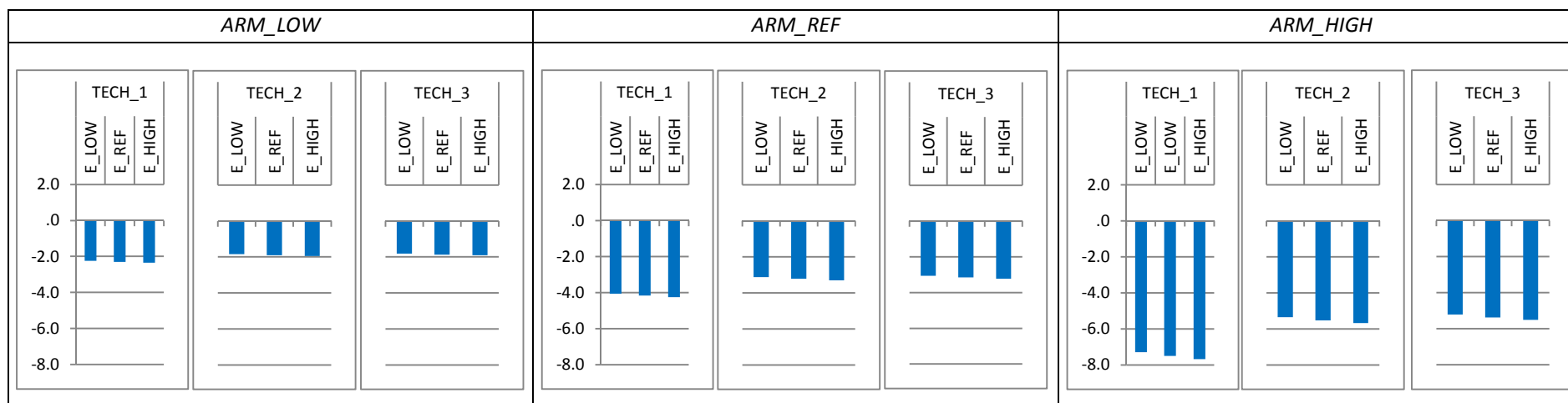

Figure 3c: Sub-sectoral output effects – EU’s aluminium sector (alu)

(a) Reference scenario



(b) Tariff scenario

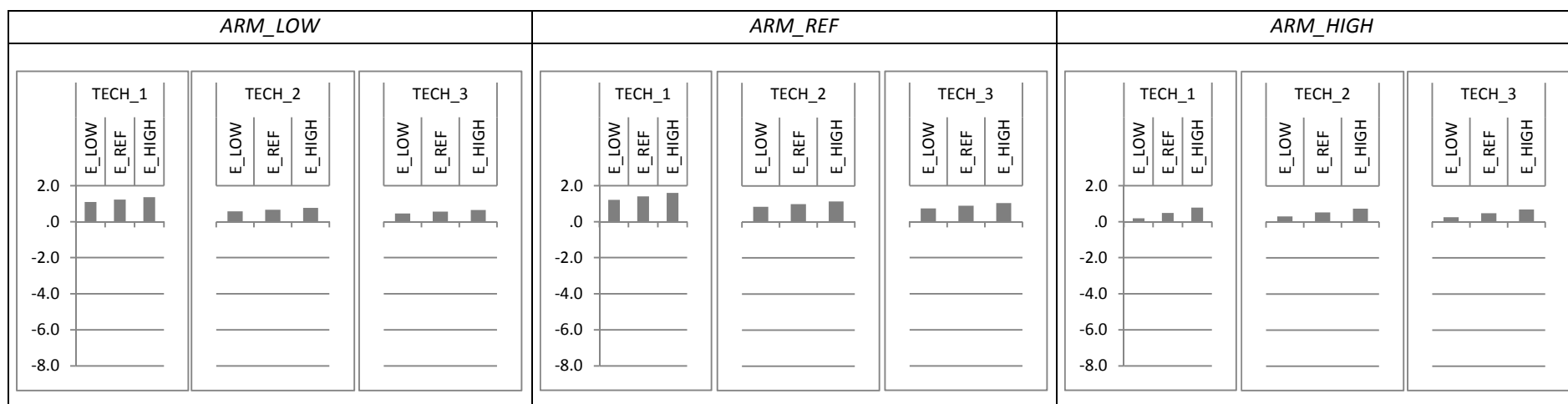
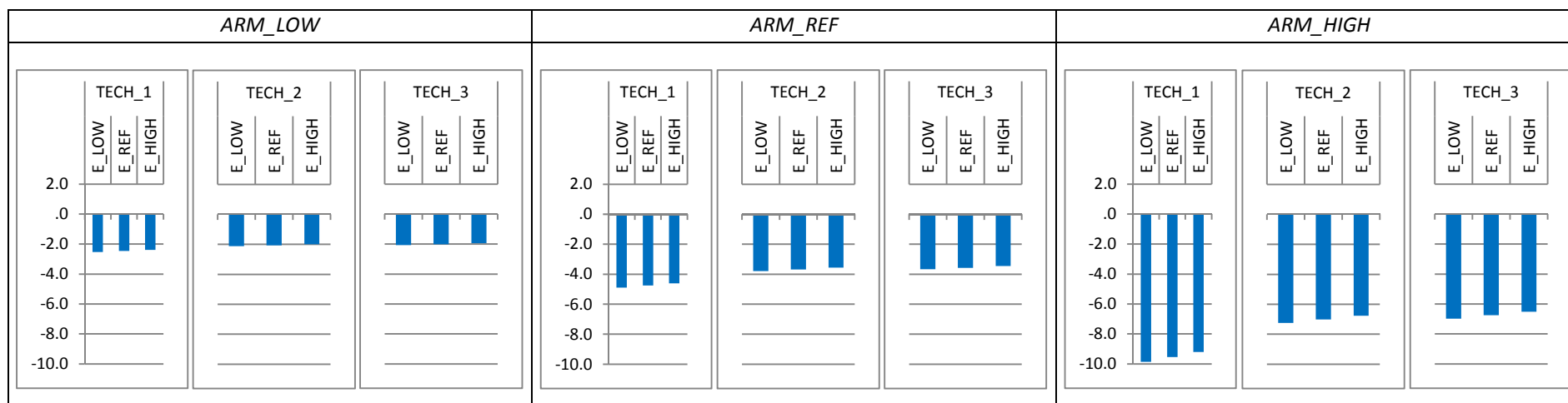

Figure 3d: Sub-sectoral output effects – EU’s other non-ferrous metals sector (onfm)

(a) Reference scenario



(b) Tariff scenario

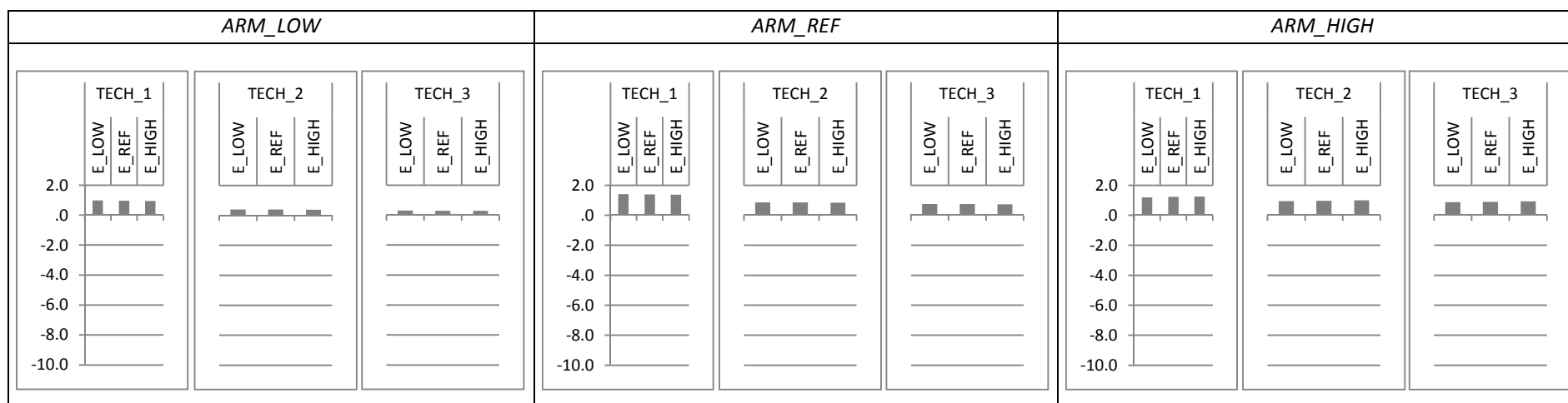
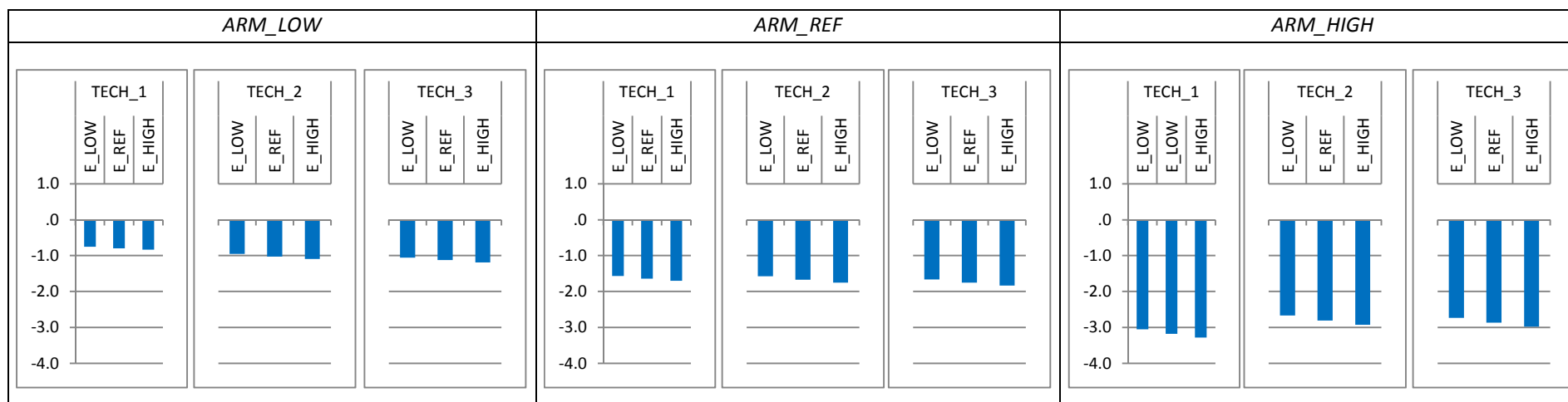

Figure 3e: Sub-sectoral output effects – EU’s iron and steel (manufacturing) sector (ism)

(a) Reference scenario



(b) Tariff scenario

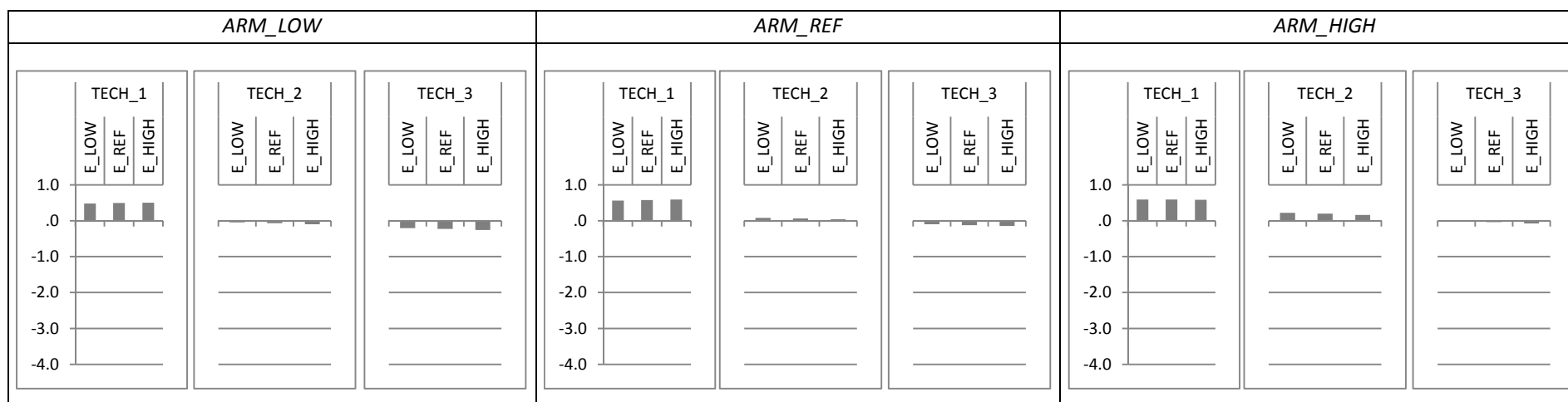
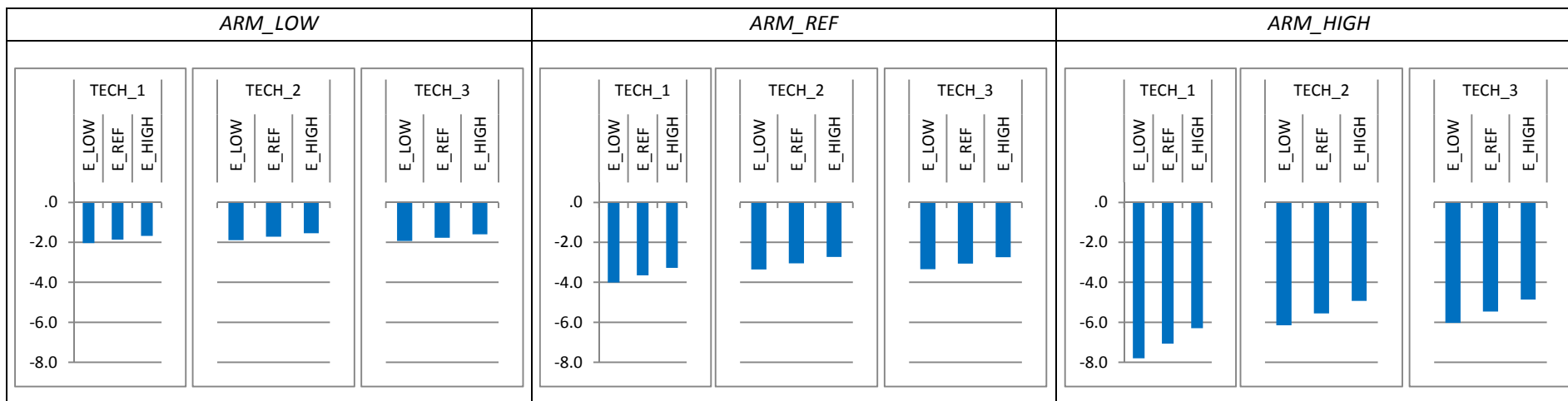

Figure 3f: Sub-sectoral output effects – EU’s iron and steel (further processing) sector (isp)

(a) Reference scenario



(b) Tariff scenario

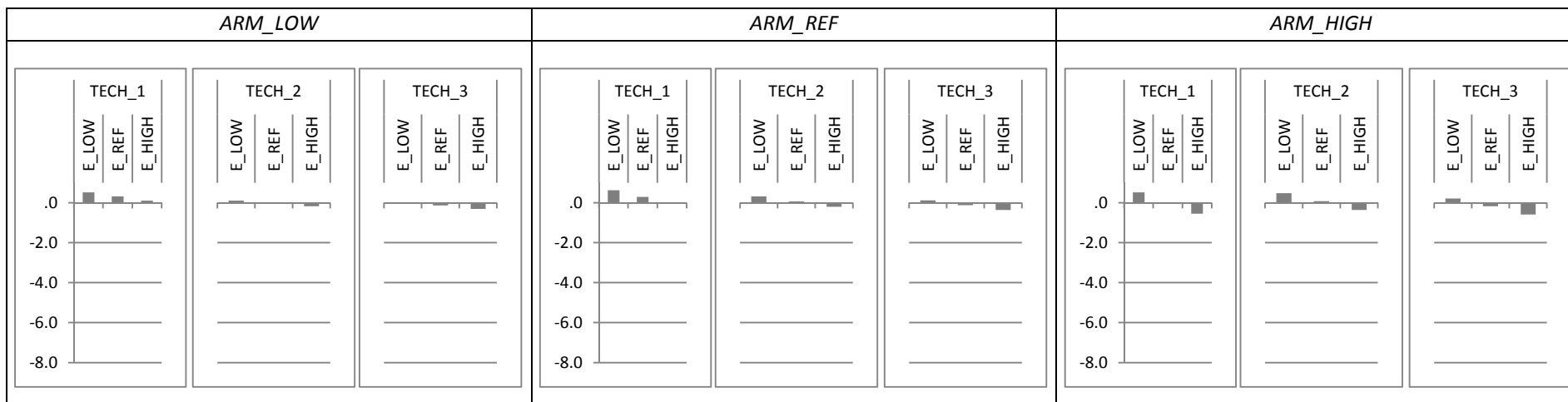
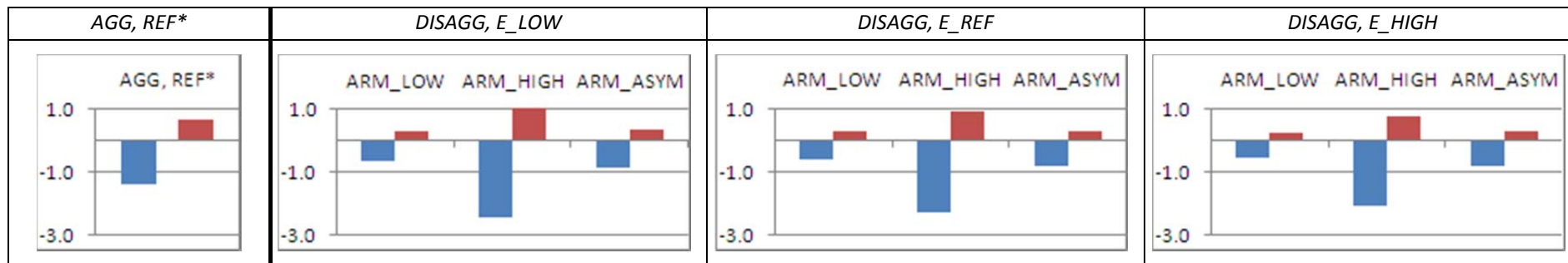
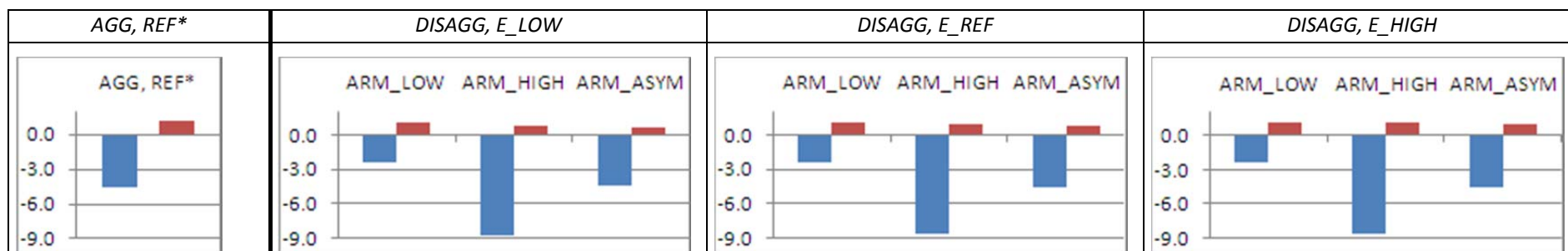

Figure 4a: Merits of disaggregation for EU – Varying energy shares and Armington elasticities for NMM, NFM and I_S, *output* effects (% vs. BaU)

(a) *TECH_1: NMM*



(b) *TECH_1: NFM*



(c) *TECH_1: I_S*

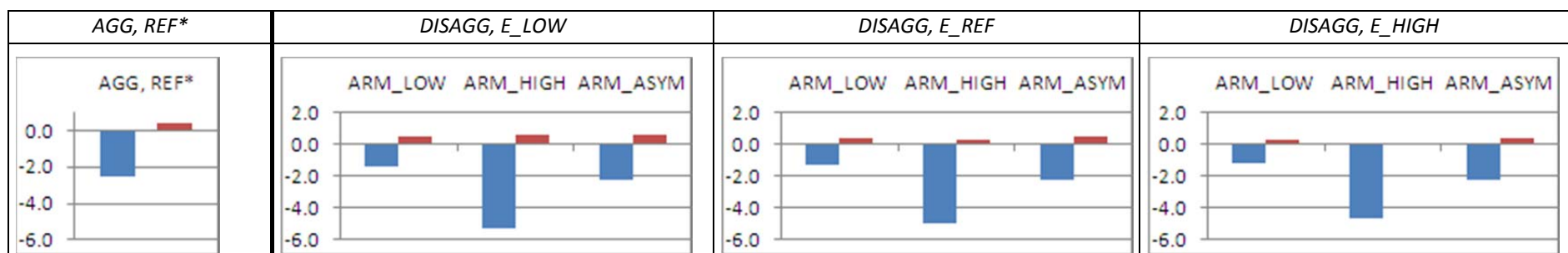

Note: In each graph, the left bar shows the results for the *reference* scenario, whereas the right bar shows the results for the *tariff* scenario.

Figure 4b: Merits of disaggregation for EU – Varying energy shares and Armington elasticities for NMM, NFM and I_S, *export* effects (% vs. BaU)

(a) *TECH_1: NMM*

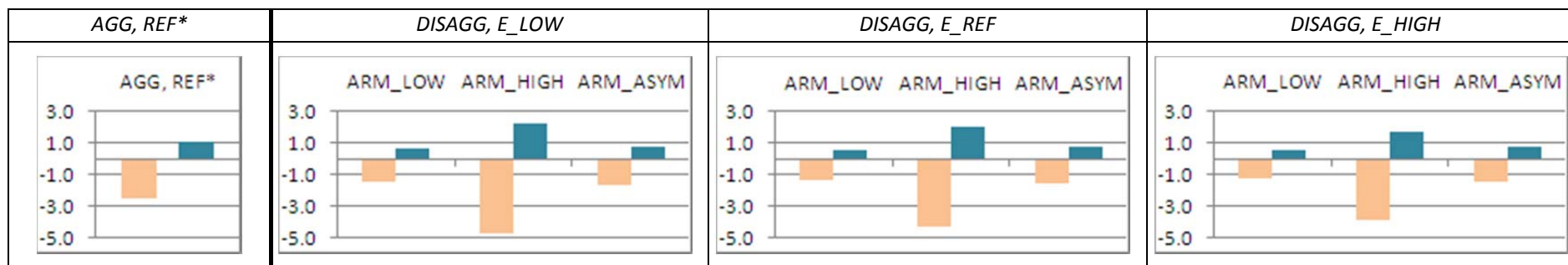

(b) *TECH_1: NFM*

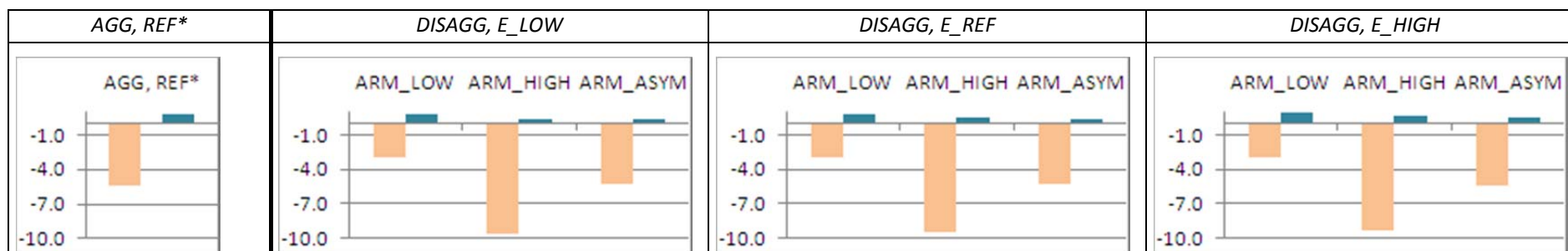

(c) *TECH_1: I_S*

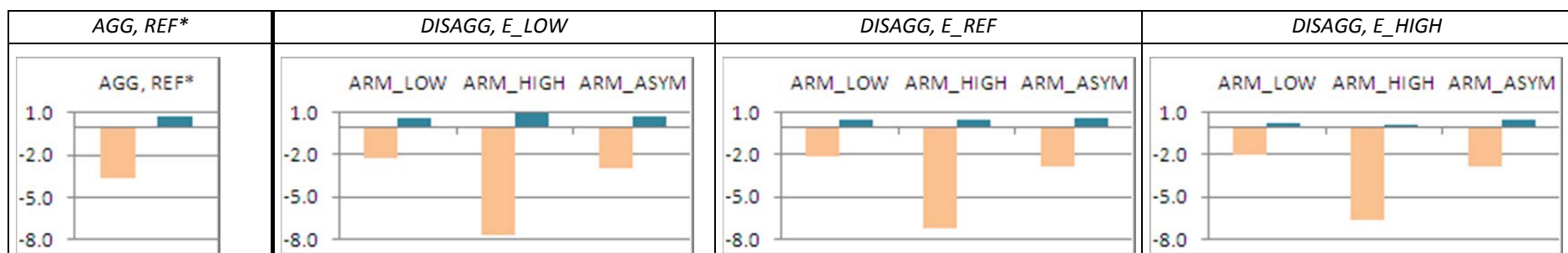

Note: In each graph, the left bar shows the results for the *reference* scenario, whereas the right bar shows the results for the *tariff* scenario.

Table 6: Merits of disaggregation – Macroeconomic and environmental implications in *reference* scenario

(a) EU's welfare impacts (% change vs. BaU)

AGG, REF*		DISAGG, E_LOW			DISAGG, E_REF			DISAGG, E_HIGH		
		ARM_LOW	ARM_REF	ARM_HIGH	ARM_LOW	ARM_REF	ARM_HIGH	ARM_LOW	ARM_REF	ARM_HIGH
TECH_1	-0.506	-0.429	-0.504	-0.622	-0.430	-0.502	-0.615	-0.429	-0.499	-0.607
TECH_2	-0.262	-0.211	-0.260	-0.335	-0.212	-0.259	-0.331	-0.212	-0.258	-0.327
TECH_3	-0.285	-0.235	-0.284	-0.357	-0.236	-0.283	-0.354	-0.236	-0.281	-0.274

(b) EU's CO2 price (US\$)

AGG, REF*		DISAGG, E_LOW			DISAGG, E_REF			DISAGG, E_HIGH		
		ARM_LOW	ARM_REF	ARM_HIGH	ARM_LOW	ARM_REF	ARM_HIGH	ARM_LOW	ARM_REF	ARM_HIGH
TECH_1	70.05	67.23	69.97	75.16	67.24	69.82	74.64	66.99	69.44	73.93
TECH_2	50.08	48.13	49.98	53.11	48.18	49.94	52.86	48.03	49.70	52.44
TECH_3	46.35	44.68	46.28	49.00	44.72	46.23	48.78	44.59	46.03	48.42

(c) EU's emissions (% change vs. BaU)

AGG, REF*		DISAGG, E_LOW			DISAGG, E_REF			DISAGG, E_HIGH		
		ARM_LOW	ARM_REF	ARM_HIGH	ARM_LOW	ARM_REF	ARM_HIGH	ARM_LOW	ARM_REF	ARM_HIGH
TECH_1	-23.42	-22.91	-23.43	-24.36	-22.89	-23.38	-24.24	-22.87	-23.33	-24.14
TECH_2	-23.31	-22.92	-23.31	-23.95	-22.91	-23.28	-23.88	-22.90	-23.25	-23.81
TECH_3	-23.27	-22.89	-23.27	-23.90	-22.88	-23.24	-23.83	-22.86	-23.21	-23.77

(d) Leakage rate (% change vs. BaU)

AGG, REF*		DISAGG, E_LOW			DISAGG, E_REF			DISAGG, E_HIGH		
		ARM_LOW	ARM_REF	ARM_HIGH	ARM_LOW	ARM_REF	ARM_HIGH	ARM_LOW	ARM_REF	ARM_HIGH
TECH_1	14.78	12.83	14.79	18.04	12.75	14.61	17.66	12.65	14.42	17.30
TECH_2	14.35	12.87	14.35	16.65	12.82	14.24	16.39	12.77	14.12	16.15
TECH_3	14.22	12.75	14.22	16.51	12.71	14.11	16.26	12.66	14.00	16.02

Table 7: Merits of disaggregation – Macroeconomic and environmental implications in *tariff* scenario

(a) EU's welfare impacts (% change vs. BaU)

AGG, REF*		DISAGG, E_LOW			DISAGG, E_REF			DISAGG, E_HIGH		
		ARM_LOW	ARM_REF	ARM_HIGH	ARM_LOW	ARM_REF	ARM_HIGH	ARM_LOW	ARM_REF	ARM_HIGH
TECH_1	-0.487	-0.503	-0.484	-0.493	-0.502	-0.484	-0.494	-0.499	-0.482	-0.492
TECH_2	-0.254	-0.270	-0.252	-0.250	-0.269	-0.252	-0.250	-0.267	-0.250	-0.250
TECH_3	-0.276	-0.291	-0.275	-0.274	-0.290	-0.275	-0.275	-0.288	-0.273	-0.350

(b) EU's CO2 price (US\$)

AGG, REF*		DISAGG, E_LOW			DISAGG, E_REF			DISAGG, E_HIGH		
		ARM_LOW	ARM_REF	ARM_HIGH	ARM_LOW	ARM_REF	ARM_HIGH	ARM_LOW	ARM_REF	ARM_HIGH
TECH_1	63.22	63.54	62.96	64.36	63.73	63.20	64.64	63.63	63.12	64.55
TECH_2	44.52	45.07	44.29	44.74	45.22	44.49	44.99	45.17	44.46	45.00
TECH_3	41.66	42.12	41.48	41.88	42.26	41.65	42.10	42.21	41.62	42.11

(c) EU's emissions (% change vs. BaU)

AGG, REF*		DISAGG, E_LOW			DISAGG, E_REF			DISAGG, E_HIGH		
		ARM_LOW	ARM_REF	ARM_HIGH	ARM_LOW	ARM_REF	ARM_HIGH	ARM_LOW	ARM_REF	ARM_HIGH
TECH_1	-22.16	-22.26	-22.13	-22.35	-22.27	-22.16	-22.39	-22.27	-22.17	-22.40
TECH_2	-22.16	-22.30	-22.13	-22.20	-22.32	-22.16	-22.24	-22.33	-22.17	-22.26
TECH_3	-22.18	-22.31	-22.15	-22.22	-22.33	-22.18	-22.26	-22.33	-22.19	-22.29

(d) Leakage rate (%)

AGG, REF*		DISAGG, E_LOW			DISAGG, E_REF			DISAGG, E_HIGH		
		ARM_LOW	ARM_REF	ARM_HIGH	ARM_LOW	ARM_REF	ARM_HIGH	ARM_LOW	ARM_REF	ARM_HIGH
TECH_1	9.93	10.28	9.80	10.68	10.34	9.91	10.83	10.34	9.93	10.87
TECH_2	9.90	10.46	9.77	10.07	10.52	9.88	10.23	10.54	9.93	10.32
TECH_3	9.99	10.50	9.87	10.19	10.57	9.98	10.36	10.59	10.03	10.45

References

- Aldy, J.E. and W.A. Pizer (2011), The Competitiveness Impacts of Climate Change Mitigation Policies, NBER Working Paper 17705, National Bureau of Economic Research, Cambridge, MA.
- Alexeeva-Talebi, V., Löschel, A. and T. Mennel (2008), Climate Policy and the Problem of Competitiveness: Border Tax Adjustments or Integrated Emission Trading?, ZEW Discussion Paper 08-061, ZEW, Mannheim.
- Alexeeva-Talebi, V., Anger, N. and A. Löschel (2010), Alleviating Adverse Implications of EU Climate Policy on Competitiveness: The Case for Border Tax Adjustments or the Clean Development Mechanism?, in: V. Ghosal (ed.), *Reforming Rules and Regulations: Laws, Institutions, and Implementation*, The MIT Press, Cambridge, MA.
- Babiker, M.H. and T.F. Rutherford (2005), The Economic Effects of Border Measures in Sub-global Climate Agreements, *The Energy Journal* 26(4), 99–126.
- Badri, N.G., Walmsley, T.L., 2008. Global trade, assistance, and production: the GTAP 7 data base. Center for Global Trade Analysis, Purdue University.
- Balistreri, E. J., Al-Qahtani, A. and C.A. Dahl (2010), Oil and Petroleum Product Armington Elasticities: A new-geography-of-trade approach to estimation, *The Energy Journal*, Volume 31(3), 167–179.
- Bauer, N., Edenhofer, O., Kypreos, S. (2008), Linking energy system and macroeconomic growth models, *Computational Management Science*, 5, 95-117.
- BEA (2012), Gross Domestic Product by Industry Data, Bureau of Economic Analysis, U.S. Department of Commerce. Available at:
http://www.bea.gov/industry/gdpbyind_data.htm
- Biørn, E., Skjerpen, T., and K.R. Wangen (2006), Can Random Coefficient Cobb Douglas Production Functions be Aggregated to Similar Macro Functions? In B. H. Baltagi, E. Sadka, and D. E. Wildasin (eds.), *Panel Data Econometrics: Theoretical Contributions and Empirical Applications* (Vols. 274, Contributions to Economic Analysis (Series), Emerald.
- Böhringer, C., Löschel, A. and H. Welsch (2008), Environmental Taxation and Induced Structural Change in an Open Economy: The Role of Market Structure, *German Economic Review* 9(1), 17–40.
- Böhringer, C., Löschel, A., Moslener, U. and T.F. Rutherford (2009), EU Climate Policy Up to 2020: An Economic Impact Assessment, *Energy Economics* 31 (S2), 295-305.
- Bosetti, V., Carraro, C., Galeotti, M., Massetti, E. and Tavoni M. (2006), WITCH. A World Induced Technical Change Hybrid Model, *The Energy Journal*, 27(2), pp. 13–38.
- Burniaux, J. M. and Truong T. (2002), GTAP-E: An Energy-Environmental Version of the GTAP Model, GTAP Technical Papers 923, Center for Global Trade Analysis, Department of Agricultural Economics, Purdue University.
- CSI (2009), Cement Industry Energy and CO₂ Performance “Getting the Numbers Right”, The Cement Sustainability Initiative, World Business Council for Sustainable Development, Geneva, Washington.

- Demailly, D. and P. Quirion (2008b), Leakage from Climate Policies and Border Tax Adjustment: Lessons From a Geographic Model of the Cement Industry, in: R. Guesnerie and H. Tulkens (eds.), *The Design of Climate Policy*, Papers from a Summer Institute in Venice, CESifo Seminar Series, The MIT Press, Boston.
- Dröge, S. (2011), Carbon pricing and its future role for energy-intensive industries – Key features of steel, cement, aluminium, chemicals, pulp&paper, Discussion Paper, Climate Strategies.
- Eberhardt, M. and F. Teal (2012), Structural Change and Cross-Country Growth Empirics, Working Paper, School of Economics, University of Nottingham.
- EU (2009a), Directive 2009/29/EC of the European Parliament and of the Council of 23 April 2009 Amending Directive 2003/87/EC so as To Improve and Extend the Greenhouse Gas Emission Allowance Trading Scheme of the Community, Brussels.
- EU (2009b), Commission Decision of 24 December 2009 Determining, Pursuant to Directive 2003/87/EC of the European Parliament and of the Council, a List of Sectors and Sub-sectors which are Deemed to be Exposed to a Significant Risk of Carbon Leakage, European Commission, Brussels.
- EU (2010), Communication from the Commission to the European Parliament, the Council, the European Economic and Social Committee and the Committee of the Regions: Analysis of Options to Move Beyond 20% Greenhouse Gas Emission Reductions and Assessing the Risk of Carbon Leakage, European Commission, Brussels.
- EurActiv (2009), EU Industry and the 'Carbon Leakage' Threat, 27 January. Available at: <http://www.euractiv.com/climate-change/carbon-leakage-challenge-eu-industry/article-176591>
- Eurostat (2011a), Statistical Offices of the European Union, Structural Business Statistics, http://epp.eurostat.ec.europa.eu/portal/page/portal/european_business/introduction
- Eurostat (2011b), Statistical Offices of the European Union, External Trade, http://epp.eurostat.ec.europa.eu/portal/page/portal/external_trade/introduction
- Eurostat (2012), Statistical Offices of the European Union, Supply and Use Tables, http://epp.eurostat.ec.europa.eu/portal/page/portal/esa95_supply_use_input_tables/methodology/supply_and_use_tables
- EXIOPOL (2011), A New Environmental Accounting Framework Using Externality Data and Input-Output Tool for Policy Analysis. Project No. 037033 under the Sixth Framework Programme of the European Commission. Database available at: www.exiobase.eu
- Feenstra, R.C., Lipsey, R.E., Deng, H., Ma, A.C., Mo, H. (2005), *World Trade Flows: 1962-2000*, NBER Working Paper 11040, National Bureau of Economic Research, Cambridge, MA.
- Feenstra, R.C., Obstfeld, M. and K.N. Russ (2011), In Search of the Armington Elasticity, paper presented at the conference “New Perspectives on International Trade, Development, and Macroeconomics”, June 16–17, 2011, Yale.
- Gallaway, M.P., McDaniel, C.A. and S.A. Rivera (2003), Short-run and long-run industry-level estimates of U.S. Armington elasticities, *North American Journal of Economics and Finance* 14, 49–68.

- Graichen, V., Schumacher, K, Matthes, F.C., Mohr, L, Duscha, V., Schleich, J. and J. Diekmann (2008), Impacts of the EU Emissions Trading Scheme on the industrial competitiveness in Germany, Research Report 3707 41 501, UBA-FB 001177, UmweltBundesamt.
- Hertel, T.H., Hummels, D., Ivanic, M. and R. Keeney (2004), How Confident Can We Be in CGE-Based Assessments of Free Trade Agreements? GTAP Working Paper No. 26, Center for Global Trade Analysis, West Lafayette, Indiana.
- R. Hillberry and D. Hummels (2011), Trade Elasticity Parameters for a CGE Model, draft chapter for Handbook of Computable General Equilibrium Modelling, D. Jorgenson and P. Dixon (eds), Elsevier.
- Horridge, M. (2008), SplitCom: Programs to disaggregate a GTAP sector, Centre of Policy Studies, Monash University, Melbourne, Australia.
- International Energy Outlook (2010), U.S. Energy Information Administration, U.S. Department of Energy, Washington, DC.
- IPCC (2007), Summary for Policymakers, in: S. Solomon, D. Qin, M. Manning, Z. Chen, M. Marquis, K.B. Averyt, M. Tignor and H.L. Miller (eds.): Climate Change 2007: The Physical Science Basis. Contribution of Working Group I to the Fourth Assessment Report of the Intergovernmental Panel on Climate Change, Cambridge University Press, Cambridge and New York.
- Kemfert, C. (2002), An integrated assessment model of economy energy-climate the model WIAGEM, *Integrated Assessment* 3(4), 281–298.
- Kim, Y. and E. Worrell, 2002a: CO₂ emission trends in the cement industry: An international comparison. *Mitigation and Adaptation Strategies for Global Change*, 7, 115-33.
- Kim, Y. and E. Worrell, 2002a: International comparison of CO₂ emissions trends in the iron and steel industry. *Energy Policy*, 30, 827-838.
- Li, P.C., Huang, C.H., Hsu, S.H., 2000. Energy substitution in CGE modelling - Using the “Technology Bundle” approach: The case of Taiwan, downloadable from the Monash website, www.monash.edu.au/policy/conf/21Hsu.pdf.
- Mathiesen, L. and O. Maestad (2004), Climate Policy and the Steel Industry: Achieving Global Emission Reductions by an Incomplete Climate Agreement, *The Energy Journal* 25(4), 91–114.
- Monjon, S. and P. Quirion (2010), Addressing leakage in the EU ETS: Border adjustment or output-based allocation?, C.I.R.E.D. Working Paper No. 25-2010, C.I.R.E.D., Nogent sur Marne.
- Monjon, S. and P. Quirion (2011a), A border adjustment for the EU ETS: Reconciling WTO rules and capacity to tackle carbon leakage, *Climate Policy* 11, 1212-1225.
- Monjon, S. and P. Quirion (2011b), Addressing leakage in the EU ETS: Border adjustment or output-based allocation?, *Ecological Economics* 70, 1957-1971.
- Okagawa, A. and K. Ban (2008), Estimation of substitution elasticities for CGE models, Discussion Paper 08-16, Graduate School of Economics and Osaka School of International Public Policy, Osaka University.

- Peterson, E.B. and J. Schleich (2007), Economic and Environmental Effects of Border Tax Adjustments, Working Paper Sustainability and Innovation S1/2007, ISI Karlsruhe, Karlsruhe.
- Sathaye, J.A. (2007), Bottom-up modeling of energy and greenhouse gas emissions: approaches, results, and challenges to inclusion of end-use technologies, in: M. E. Schlesinger et al. (eds.), Human-Induced Climate Change: An Interdisciplinary Assessment, Cambridge University Press, Cambridge.
- Schumacher, K., Sands, R.D. (2007), Where are the industrial technologies in energy-economy models? An innovative CGE approach for steel production in Germany, *Energy Economics*, 29, 799-825.
- Sjardin, M., 2003: CO2 emission factors for non-energy use in the non-ferrous metal, ferroalloys and inorganics industry. Copernicus Institute, Utrecht, 63.
- Stoker, T. M. (1993). Empirical Approaches to the Problem of Aggregation Over Individuals. *Journal of Economic Literature*, 31(4), 1827-1874.
- Tamiotti, L., Teh, R., Kulaçoğlu, V., Olhoff, A., Simmons, B. and H. Abaza (2009), Trade and Climate Change – A report by the United Nations Environment Programme and the World Trade Organization. Available online at:
http://www.wto.org/english/res_e/booksp_e/trade_climate_change_e.pdf
- Temple, J. and L. Wößmann (2006), Dualism and cross-country growth regressions, *Journal of Economic Growth* 11(3), 187-228.
- UN (2011a), United Nations Industrial Commodity Statistics Database, <http://data.un.org/Browse.aspx?d=ICS>
- UN (2011b), United Nations Commodity Trade Statistics Database, <http://comtrade.un.org/>
- USGS (2006), Minerals Yearbook 2006, United States Geological Survey, Reston, VA.
- Walker, N. (2006), Concrete Evidence? An Empirical Approach to Quantify the Impact of EU Emissions Trading on Cement Industry Competitiveness, Working Paper PEP 06/10, Planning and Environmental Policy Research Series, University College Dublin.
- Welsch, H. (2008), Armington elasticities for energy policy modelling: Evidence from four European countries, *Energy Economics*, 30, 2252-2264.
- Winchester, N., Paltsev, S., Reilly, J.M. (2011), Will border carbon adjustments work?, *The B.E. Journal of Economics*, 11(1) (Topics), Article 7.

Appendix

Table 8: Regions and sectors in PACE for the aggregated and the disaggregated database versions

Region	Sector
China (CHN)	ENERGY GOODS:
India (IND)	Coal (COL)
United States (USA)	Refined petroleum and coal products (OIL)
Russia (RUS)	Crude oil (CRU)
EU27 and EFTA (EUR)	Natural gas (GAS)
Other Annex 1 (RA1)	Electricity (ELE)
Energy exp. countries excl. Mexico (EEX)	ENERGY-INTENSIVE TRADE GOODS:
Other middle income countries (MIC)	Non-ferrous metals (agg) (NFM)
Other low income countries (LIC)	Aluminium (disagg) (ALU)
	Other non-ferrous metals (disagg) (ONFM)
	Iron and steel (agg) (I_S)
	Manufacturing of iron and steel (disagg) (ISM)
	Further processing of iron and steel (disagg) (ISP)
	Non-metallic minerals (agg) (NMM)
	Cement, lime and plaster (disagg) (CEM)
	Other non-metallic minerals (disagg) (ONMM)
	Chemical products (CRP)
	TRANSPORT:
	Air transport (ATP)
	Water transport (WTP)
	Other transport (OTP)
	ALL OTHER GOODS (AOG)

Table 9: Columns and rows for selected sectors of the input output tables of the aggregated and disaggregated dataset for EU27 and EFTA

	agg			disagg			agg			disagg			agg			disagg			ele	otp	wtp	COL	CRU	AOG	INT_TAX	PRIVATE	GOVERNMENT	INVEST	EXPORT	TOT_DEM
	oil	gas	crp	nmm	cem	onmm	i_s	ism	isp	nfm	alu	onfm	ele	otp	wtp	COL	CRU	AOG	INT_TAX	PRIVATE	GOVERNMENT	INVEST	EXPORT	TOT_DEM						
oil				12.324	5.592	6.728	10.898	5.942	4.953	1.311	0.42	0.891																		
gas				2.969	1.45	1.519	1.795	0.962	0.859	0.489	0.175	0.317																		
crp				13.665	5.563	7.927	5.284	2.874	2.345	5.836	1.917	3.766																		
agg	nmm	0.375	0.187	11.871	58.539		11.934			10.19			1.902	1.046	0.063	0.093	0.176	237.945	0.019	27.57	0.023	2.517	81.148	445.605						
disagg	cem	0.032	0.024	3.004		10.353	8.493		0.883	0.782		0.193	0.379	0.275	0.023	0.039	0.053	105.816	-0.005	13.86	0.009	1.207	13.303	159.055						
	onmm	0.345	0.165	7.927		19.217	20.994		5.577	4.559		2.943	6.519	1.526	0.491	0.034	0.053	0.121	128.768	0.015	14.729	0.015	1.414	67.845	283.258					
agg	i_s	0.103	0.073	3.271	3.055		57.901			3.137			0.76	0.787	0.015	0.098	0.063	174.301	-0.074	0.577	0.002	2.038	110.101	356.232						
disagg	ism	0.043	0.043	1.49		0.66	0.846		17.809	15.706		0.507	0.906	0.285	0.333	0.008	0.042	0.042	93.792	-0.025	0.373	0.001	0.774	24.686	158.321					
	isp	0.049	0.024	0.981		0.611	0.829		12.907	11.8		0.556	1.129	0.362	0.278	0.006	0.047	0.02	79.897	-0.054	0.214	0.001	1.324	85.415	196.41					
agg	nfm	0.052	0.017	6.638	0.904		4.273			36.182			0.388	0.212	0.009	0.017	0.021	107.946	-0.189	0.838		5.075	83.682	246.068						
disagg	alu	0.021	0.006	1.424		0.057	0.064		0.886	0.777		5.327	8.678	0.119	0.054	0.001	0.004	0.006	39.602	-0.069	0.323		1.96	35.088	94.329					
	onfm	0.033	0.011	3.959		0.245	0.271		1.456	1.268		8.579	13.938	0.217	0.101	0.005	0.01	0.013	67.353	-0.126	0.553		3.254	48.58	149.723					
ele				13.075	5.484	7.59	17.637	9.49	8.144	12.344	4.806	7.533																		
otp				20.855	7.593	13.023	8.205	4.393	3.712	3.976	1.224	2.669																		
wtp				0.992	0.268	0.713	1.152	0.585	0.556	0.562	0.279	0.274																		
COL				0.461	0.237	0.221	0.193	0.106	0.087	0.022	0.013	0.009																		
CRU																														
AOG				80.927	32.154	47.821	57.569	30.662	26.264	34.73	14.422	19.534																		
OUT_TAX				12.565	3.157	9.279	4.148	2.195	1.929	2.117	0.76	1.32																		
LABOR				81.129	32.706	47.087	42.207	22.177	19.327	23.025	8.804	13.49																		
CAPITAL				48.231	19.593	28.063	21.982	11.763	9.947	12.816	4.715	7.8																		
IMPORT				94.946	13.724	81.222	110.536	27.37	83.165	98.946	38.496	60.433																		
TOT_SUP				445.605	159.055	283.258	356.232	158.321	196.41	246.068	94.329	149.723																		
CARBON				121.93	83.124	38.43	82.623	64.505	18.252	13.951	8.981	5.014																		

Table 10: Input output table of the aggregated dataset for EU27 and EFTA

EUR, agg	oil	gas	crp	nmm	i_s	nfm	ele	otp	wtp	atp	COL	CRU	AOG	INT_TAX	PRIVATE	GOVERNMENT	INVEST	EXPORT	TOT_DEM
oil	91.669	0.178	72.163	12.324	10.898	1.311	17.351	159.282	20.418	46.145	0.039	0.092	42.883	-197.043	70.327			62.286	410.322
gas	4.234	1.98	6.686	2.969	1.795	0.489	19.962	0.404	0.008	0.011	0.004	0.002	12.322	-2.622	18.712		0.001	17.351	84.309
crp	2.633	0.165	310.88	13.665	5.284	5.836	2.56	10.398	0.619	0.44	0.315	0.564	493.023	1.122	198.611	31.347	2.059	639.137	1718.658
nmm	0.375	0.187	11.871	58.539	11.934	10.19	1.902	1.046	0.063	0.006	0.093	0.176	237.945	0.019	27.57	0.023	2.517	81.148	445.605
i_s	0.103	0.073	3.271	3.055	57.901	3.137	0.76	0.787	0.015	0.025	0.098	0.063	174.301	-0.074	0.577	0.002	2.038	110.101	356.232
nfm	0.052	0.017	6.638	0.904	4.273	36.182	0.388	0.212	0.009		0.017	0.021	107.946	-0.189	0.838		5.075	83.682	246.068
ele	5.6	0.863	32.664	13.075	17.637	12.344	19.268	11.114	0.244	0.423	1.758	0.214	161.785	-19.708	114.713			18.898	390.894
otp	1.573	0.395	25.737	20.855	8.205	3.976	4.862	211.573	46.613	33.704	0.541	0.823	405.565	0.176	214.666	29.105	2.264	127.695	1138.325
wtp	0.116	0.045	2.514	0.992	1.152	0.562	1.066	5.584	26.753	0.341	0.033	0.244	10.678	0.042	13.22	0.202	1.499	152.947	217.99
atp	0.06	0.056	2.677	0.967	0.518	0.385	0.288	19.001	0.57	10.534	0.045	0.4	72.153	0.009	70.992	0.255	0.241	93.451	272.603
COL	4.506	0.033	0.182	0.461	0.193	0.022	19.567	0.001			0.025		0.292	0.112	0.577			1.416	27.388
CRU	177.583	0.01	0.008				0.007	0.001				0.034	0.005	0.000	0.003		0.003	48.219	225.872
AOG	6.395	5.892	259.719	80.927	57.569	34.73	84.099	244.455	33.304	54.924	6.03	9.047	8538.65	-6.659	6413.808	2764.968	2639.932	3027.135	24254.92
OUT_TAX	33.539	1.228	42.078	12.565	4.148	2.117	19.387	7.333	0.301	3.101	-4.278	0.977	381.147						
LABOR	4.361	11.126	209.286	81.129	42.207	23.025	67.938	210.375	24.246	33.139	9.676	22.737	6178.56						
CAPITAL	6.233	17.919	154.067	48.231	21.982	12.816	113.876	167.303	25.166	16.191	1.819	37.34	4323.27						
IMPORT	71.29	44.141	578.217	94.946	110.536	98.946	17.613	89.458	39.662	73.62	11.173	153.139	3114.4						
TOT_SUP	410.322	84.309	1718.66	445.605	356.232	246.068	390.894	1138.33	217.99	272.603	27.388	225.872	24254.9						
CARBON	67.302	19.579	114.516	121.93	82.623	13.951	1413.14	601.311	115.042	152.158	1.948	16.476	376.654		972.184	0.002			4068.816

Table 11: Input output table of the disaggregated dataset for EU27 and EFTA

EUR, disagg	oil	gas	crp	cem	onmm	ism	isp	alu	onfm	ele	otp	wtp	atp	COL	CRU	AOG	INT_TAX	PRIVATE	GOVERNMENT	INVEST	EXPORT	TOT_DEM
oil	91.669	0.178	72.168	5.592	6.728	5.942	4.953	0.42	0.891	17.351	159.282	20.418	46.145	0.039	0.092	42.884	-197.043	70.326			62.286	410.322
gas	4.234	1.98	6.686	1.45	1.519	0.962	0.859	0.175	0.317	19.962	0.404	0.008	0.011	0.004	0.002	12.322	-2.625	18.712		0.001	17.351	84.334
crp	2.632	0.164	311.228	5.563	7.927	2.874	2.345	1.917	3.766	2.56	10.398	0.618	0.439	0.314	0.563	492.473	1.122	198.369	31.286	2.056	639.137	1717.752
cem	0.032	0.024	3.004	10.353	8.493	0.883	0.782	0.193	0.333	0.379	0.275	0.023		0.039	0.053	105.816	-0.005	13.86	0.009	1.207	13.303	159.055
onmm	0.345	0.165	7.927	19.217	20.994	5.577	4.559	2.943	6.519	1.526	0.491	0.034		0.053	0.121	128.768	0.015	14.729	0.015	1.414	67.845	283.258
ism	0.043	0.043	1.49	0.66	0.846	17.809	15.706	0.507	0.906	0.285	0.333	0.008		0.042	0.042	93.792	-0.025	0.373	0.001	0.774	24.686	158.321
isp	0.049	0.024	0.981	0.611	0.829	12.907	11.8	0.556	1.129	0.362	0.278	0.006	0.015	0.047	0.02	79.897	-0.054	0.214	0.001	1.324	85.415	196.41
alu	0.021	0.006	1.424	0.057	0.064	0.886	0.777	5.327	8.678	0.119	0.054	0.001		0.004	0.006	39.602	-0.069	0.323		1.96	35.088	94.329
onfm	0.033	0.011	3.959	0.245	0.271	1.456	1.268	8.579	13.938	0.217	0.101	0.005		0.01	0.013	67.353	-0.126	0.553		3.254	48.58	149.723
ele	5.6	0.863	32.665	5.484	7.59	9.49	8.144	4.806	7.533	19.268	11.114	0.244	0.423	1.758	0.214	161.785	-19.707	114.713			18.898	390.887
otp	1.573	0.396	25.794	7.593	13.023	4.393	3.712	1.224	2.669	4.862	211.581	46.607	33.703	0.541	0.822	405.654	0.176	214.6	29.101	2.263	127.694	1137.981
wtp	0.116	0.046	2.522	0.268	0.713	0.585	0.556	0.279	0.274	1.067	5.588	26.756	0.341	0.033	0.244	10.681	0.042	13.221	0.202	1.499	152.946	217.977
atp	0.06	0.056	2.684	0.391	0.569	0.284	0.23	0.194	0.183	0.288	19.003	0.57	10.533	0.045	0.4	72.166	0.009	70.986	0.255	0.241	93.451	272.598
COL	4.506	0.033	0.182	0.237	0.221	0.106	0.087	0.013	0.009	19.567	0.001			0.025		0.292	0.112	0.577			1.416	27.385
CRU	177.583	0.01	0.008							0.007	0.001				0.034	0.005	0.000	0.003		0.003	48.219	225.872
AOG	6.397	5.901	260.309	32.154	47.821	30.662	26.264	14.422	19.534	84.149	244.478	33.3	54.924	6.034	9.048	8539.58	-6.658	6411.668	2764.363	2640.718	3027.135	24252.2
OUT_TAX	33.539	1.23	42.042	3.157	9.279	2.195	1.929	0.76	1.32	19.386	7.332	0.301	3.101	-4.277	0.977	381.104						
LABOR	4.363	11.137	210.029	32.706	47.087	22.177	19.327	8.804	13.49	67.984	210.454	24.249	33.15	9.68	22.739	6179.7						
CAPITAL	6.236	17.926	154.434	19.593	28.063	11.763	9.947	4.715	7.8	113.934	167.354	25.167	16.192	1.819	37.342	4323.94						
IMPORT	71.29	44.141	578.217	13.724	81.222	27.37	83.165	38.496	60.433	17.613	89.458	39.662	73.62	11.173	153.139	3114.4						
TOT_SUP	410.322	84.334	1717.75	159.055	283.258	158.321	196.41	94.329	149.723	390.887	1137.98	217.977	272.598	27.385	225.872	24252.2						
CARBON	67.273	19.575	114.531	83.124	38.43	64.505	18.252	8.981	5.014	1413.41	601.322	115.044	152.16	1.948	16.466	376.64		972.136	0.002			4068.815

Figure 5: Simplified representation of the nesting structures used in the sensitivity analysis

TECH_1

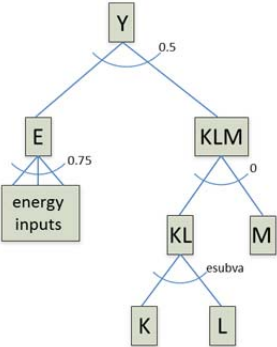

TECH_2

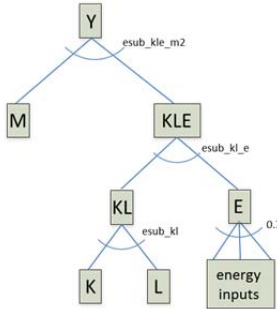

TECH_3

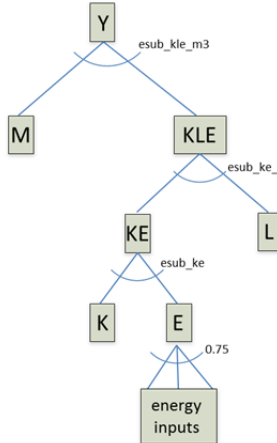

Table 12: Substitution elasticities for the three nesting structures

	CEM	ONMM	ALU	ONFM	ISM	ISP
<i>esub_kle_m2</i>	0.30	0.30	0.30	0.30	1.17	1.17
<i>esub_kle_m3</i>	0.99	0.99	0.99	0.99	1.05	1.05
<i>esub_kl_e</i>	0.41	0.41	0.41	0.41	0.64	0.64
<i>esub_ke_l</i>	0.21	0.21	0.21	0.21	0.25	0.25
<i>esubva</i>	1.26	0.71	1.26	1.26	1.26	1.26
<i>esub_kl</i>	0.36	0.36	0.36	0.36	0.22	0.22
<i>esub_ke</i>	0.35	0.35	0.35	0.35	0.29	0.29
<i>Armington el. (reference case)</i>	2.90	1.95	4.20	4.20	2.95	2.95

Note: Values for TECH_2 and TECH_3 are taken from Okagawa and Ban (2008) and were rescaled to match our sectoral structures. Values for TECH_1