

Reichl, Wolfgang; Ruhle, Ernst-Wolfgang; Lundborg, Martin; Ehrler, Matthias

Conference Paper

Virtual unbundling: The basis for competition in next generation access networks?

23rd European Regional Conference of the International Telecommunications Society (ITS), Vienna, Austria, 1st-4th July, 2012

Provided in Cooperation with:

International Telecommunications Society (ITS)

Suggested Citation: Reichl, Wolfgang; Ruhle, Ernst-Wolfgang; Lundborg, Martin; Ehrler, Matthias (2012) : Virtual unbundling: The basis for competition in next generation access networks?, 23rd European Regional Conference of the International Telecommunications Society (ITS), Vienna, Austria, 1st-4th July, 2012, International Telecommunications Society (ITS), Calgary

This Version is available at:

<https://hdl.handle.net/10419/60360>

Standard-Nutzungsbedingungen:

Die Dokumente auf EconStor dürfen zu eigenen wissenschaftlichen Zwecken und zum Privatgebrauch gespeichert und kopiert werden.

Sie dürfen die Dokumente nicht für öffentliche oder kommerzielle Zwecke vervielfältigen, öffentlich ausstellen, öffentlich zugänglich machen, vertreiben oder anderweitig nutzen.

Sofern die Verfasser die Dokumente unter Open-Content-Lizenzen (insbesondere CC-Lizenzen) zur Verfügung gestellt haben sollten, gelten abweichend von diesen Nutzungsbedingungen die in der dort genannten Lizenz gewährten Nutzungsrechte.

Terms of use:

Documents in EconStor may be saved and copied for your personal and scholarly purposes.

You are not to copy documents for public or commercial purposes, to exhibit the documents publicly, to make them publicly available on the internet, or to distribute or otherwise use the documents in public.

If the documents have been made available under an Open Content Licence (especially Creative Commons Licences), you may exercise further usage rights as specified in the indicated licence.

VIRTUAL UNBUNDLING – THE BASIS FOR COMPETITION IN NEXT GENERATION ACCESS NETWORKS?

by

DI Wolfgang Reichl
Dr. Ernst-Olav Ruhle
Martin Lundborg. M.Sc.
Dipl.-Vw. Matthias Ehrler

SBR Juconomy Consulting AG
Parkring 10/1/10, 1010 Vienna
Nordstrasse 116, D-40477 Düsseldorf

Corresponding author: Reichl@sbr-net.com

Abstract

Next Generation Access Networks will enable much higher bandwidths than copper based access networks. Although technological progress provides for higher bandwidth on copper as well, most experts agree that next generation access networks finally will be based on fibre optic cables in the entire or part of the access networks. In order to accomplish the migration towards Next Generation Access Networks, high investment is needed and various models for co-operation and co-financing are tried out worldwide.

What does the deployment of fibre optic cables in the access networks mean for the wholesale market and competition? Unbundling of copper cables has been the basis for infrastructure based competition in telecommunications networks especially in the European environment for more than a decade. Unbundling of fibre is an option in case of point to point

architectures. Current solutions of Fibre-to-the-Curb and Fibre-to-the-Building technologies rely on sharing of fibre infrastructures and make physical unbundling cumbersome. Does this mean the end of physical unbundling and is bitstream access the wholesale product of the future?

The United Kingdom and Austria lead the way by introduction of virtual unbundling. Virtual unbundling is designed to best replicate physical unbundling of the copper cable and is introduced by OFCOM and RTR as a remedy in Market 4 – physical network infrastructure access.¹ British Telecom (BT) and A1 Telekom Austria are obliged to offer virtual unbundling in geographical regions where physical unbundling of copper lines is not possible. With the introduction of virtual unbundling a couple of (research) questions arise:

- What is the difference between virtual unbundling and bitstream access? Other regulatory authorities require similar remedies in Market 5 – wholesale broadband access.
- Regulatory authorities require that virtual unbundling offers a similar freedom of design for competitors as physical unbundling and a number of technical and commercial features. Is it technically possible to implement these requirements?
- How should virtual unbundling be designed in order to form the basis for competition in next generation access networks?
- How will virtual unbundling influence the broadband markets?
- Does virtual unbundling contribute to investment in NGA?
- Under what conditions does virtual unbundling make sense?

This paper addresses the wholesale product virtual unbundling. In the first chapter the evolution of technologies in the access network from copper to fibre optic cables is demonstrated. In particular, the associated change in wholesale products and regulatory approaches for NGA are described. In the second part virtual unbundling is introduced as a new wholesale product. Experiences are drawn from the United Kingdom and Austria. The third part of this paper analyses the research questions with regard to virtual unbundling. The last chapter encompasses a debate about the future of virtual unbundling and analyses in particular whether virtual unbundling is an interim solution which will be replaced by physical unbundling of fibre optic cables or if virtual unbundling will form the basis for enduring competition in Next Generation Access Networks.

¹ see [EC 2007]

1 Background

The first decade of the 21st century saw a steady transformation of telecommunications networks into Next Generation Networks (NGN). The term NGN has been coined by the ITU-T and is used to describe a service neutral network using packet-based technology and broadband access. The drivers for the transition are mostly economic. Since technological progress allows implementing services (including voice and data) as software upon packet-based technology, economies of scale can be exploited by using cheap mass-market IT equipment to implement telecommunications networks. Today's core networks use high-performance packet-based technology and transmission capacity of optical fibres. The access network is, however, the remaining bottleneck.

It has been recognized that internet access is a driver for economic growth and fast broadband data access is high on the political agenda of many countries all over the world. The measures set by the different countries to foster the rollout of fast broadband networks vary, however. Some countries have developed national master plans for the rollout of new networks (most notable Australia), while other countries are trying to create a conducive environment for the rollout of broadband networks. Political and regulatory attention has in the last years shifted away from the core networks towards access networks. The main question is how to set the right incentives for investments.

In 2010, the European Commission issued the recommendation on regulated access to next generation access networks.² NGA is defined by the European Commission as being:

"..... wired access networks which consist wholly or in part of optical elements and which are capable of delivering broadband access services with enhanced characteristics (such as higher throughput) as compared to those provided over already existing copper networks. In most cases NGAs are the result of an upgrade of an already existing copper or co-axial access network".

With the regulatory framework for NGA the European Commission continues and further develops the current regulatory regime. According to the analysis of Ruhle and Lundborg (2010) this implies that the development of access regulation will remain dynamic, but at the cost of simplicity and straight-forwardness. They also find that the recommendations made may lead to many different potential results regarding investment incentives and the

² EC, 2010

promotion of competition. In several aspects, e.g., the approach regarding the implementation of volume discounts and long-term pricing differentiations, there are substantial risks that competition is not promoted to the required extent. On the other hand, Ruhle and Lundborg (2010) find that the obligation to provide migration paths and to regulate passive engineering infrastructure means that the competitors and wholesale customers will receive more regulatory support.³

1.1 Evolution of access networks

Telecommunications networks can, broadly speaking, be divided into access and core networks. Access networks provide the last mile to the customer and are the most expensive part of the network (as seen in the cost structure and pricing of end user access lines and backhaul/backbone services). Economies of scale do not apply extensively in the access network since every access line is assigned to a specific customer and only used by this customer.

Various technologies are being used in the access network. Access networks in voice telecommunications used to be based on copper loops and have achieved nearly ubiquitous coverage in developed countries. Cable networks have been rolled out for the delivery of television services. These networks were designed for unidirectional use and have been upgraded for bidirectional use later on. Still these networks are not best suited for symmetrical access and have not achieved universal coverage. Wireless networks have become ubiquitous but are not (yet) optimally suited to deliver high-speed broadband.

Copper networks form the basis for today's broadband networks. Although technological evolution allows exploitation of copper to achieve high bandwidths (the "second life" of copper), this is restricted to short distances. It is widely accepted that fibre optic cables, long established in the core network, will also be implemented in the access network. Heralded more than ten years ago, the progress of the implementation of fibre in the access networks is still low. Point to point fibre to the premises (FTTP) technology, where every home gets a dedicated fibre optic cable is still in most countries the long term goal.

³ Ruhle and Lundborg (2010)

The different access technologies are shown in the figure below, including the traditional non-NGA technology based on copper, the hybrid technology with fibre to the street cabinet and copper from there to the end user (FttCabinet), the FttBuilding technology using fibre in combination with existing in house cabling and FttHome using fibre all the way to the end users wall socket.

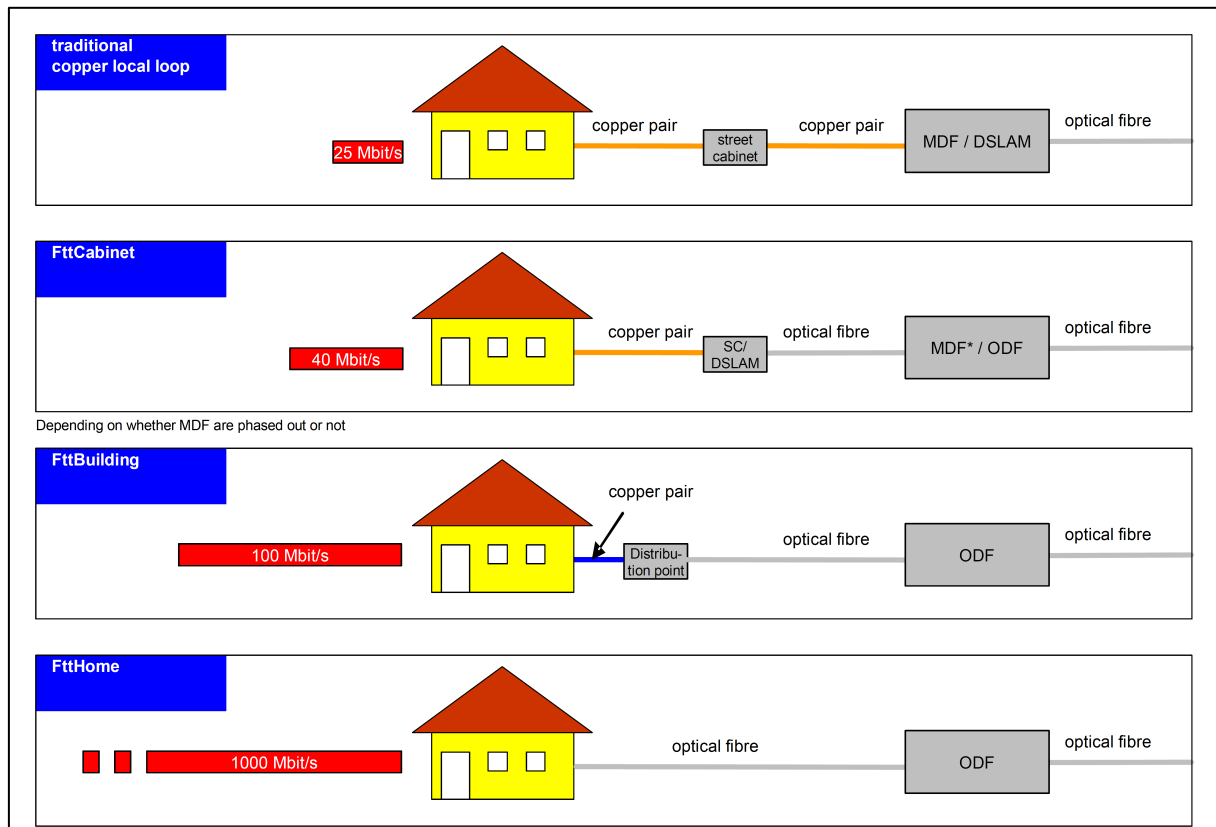

Figure 1: Access architectures (source ARCEP)

[ERG (2007)] distinguishes two scenarios to implement these architectures. The implementation of fibre to the cabinet (FTTC) is a hybrid solution, where fibre is deployed to the street cabinet and DSL technologies are being used on the copper lines between the street cabinet and the end user. FTTH/FTTB can be implemented as point to point or point to multipoint fibre architecture. In point to multipoint architectures fibre optic cables are shared between the main distribution and a passive splitter, from which dedicated fibres run to each home/building.

Physical unbundling is still possible for the remaining copper loop in a FTTC scenario. This however requires the competitor to extend its network towards the street cabinets. The

respective wholesale remedy is called subloop unbundling. Physical unbundling is also possible if point to point fibre architecture is used. In the remaining cases physical unbundling is not feasible, since the fibre is shared between various customers.

1.2 Regulating the access networks

One of the typical aims of telecoms regulation is to facilitate investments and enabling and sustaining competition. It is recognized that competition should occur at the deepest level of infrastructure. This means that facility-based competition is the preferred way forward. Although, copper/fibre based networks, cable networks and wireless networks are able to deliver broadband services, opinions differ whether this constitutes facility-based competition or not. The U.S.A. and Europe have chosen different paths in regulating next generation access networks.⁴

In the U.S.A., the final steps of liberalization of local telecommunications services were introduced in 1996 and were at first accelerated by intensive unbundling regulations. Since then, network convergence has had a significant impact on U.S. unbundling policy. Beginning in 2003, U.S. unbundling legislation has been limited to the provision of narrowband access to the copper local loop. For competition in broadband access services, the U.S. regulatory regime relies mainly on infrastructure-platform competition from Cable-TV networks and high speed wireless technologies.

Europe's Digital Agenda sets targets for the deployment and takes up of fast and very fast broadband, and foresees a number of measures to foster the deployment of NGA based on optical fibre and to support the substantial investments required in the coming years. The main policy document is the recommendation on regulated access to Next Generation Access Networks (NGA).⁵

⁴ Vogelsang, 2005

⁵ EC 2010

The European regulatory framework for NGA aims at a consistent implementation of remedies in Markets 4 and 5. It therefore relies on the principle of SMP regulation. The relevant product and service markets have been described by the European Commission in [EC 2007]. Market 4 and 5 are defined as follows:

- **Market 4:** Wholesale (physical) network infrastructure access (including shared or fully unbundled access) at a fixed location.
- **Market 5:** Wholesale broadband access. This market comprises non-physical or virtual network access including 'bitstream' access at a fixed location. This market is situated downstream from the physical access covered by Market 4 listed above, in that wholesale broadband access can be constructed using this input combined with other elements.

Typical remedies being applied to companies which have significant market power in Market 4 are unbundling of the copper loop, subloop unbundling and access to passive infrastructure (e.g. distribution frames, ducts and dark fibre). Typical Market 5 remedies are ADSL wholesale and bitstream access.

With regard to Next Generation Access the recommendation determines the following principles:

- Where duct capacity is available, access to civil engineering infrastructure should be mandated.
- Where an SMP operator deploys FTTH, NRAs should, in addition to mandating access to civil engineering infrastructure, mandate access to the terminating segment of the access network of the SMP operator, including wiring inside buildings. This type of access should be provided at cost-oriented prices.
- Unbundled access to the fibre loop should be mandated for FTTH infrastructures. An exception could be justified in areas where several alternative infrastructures are likely to result in effective competition.
- When FTTC infrastructure is deployed, NRAs should mandate unbundled access to the sub-loop. A copper sub-loop unbundling remedy should be supplemented by backhaul measures, including fibre and Ethernet backhaul where appropriate, and by ancillary remedies ensuring its effectiveness and viability, such as non-discriminatory access to facilities for co-location, or in their absence, equivalent co-location.

With the NGA recommendation the European Commission has reiterated the existing policy framework. Preference is given to physical access to NGA infrastructures, although it is recognized that the implementation of physical access depends on the deployed technology. While access to a fibre loop in an FTTH point to point infrastructure can easily be accomplished, unbundling of PON implementation is more complex and costly. Next

generation access is not seen by the European Commission as a reason to deviate from access obligations. The request for regulatory holidays which has been voiced by many incumbent operators has been turned down.

The deployment of real NGA infrastructures have kindled the discussion about remedies in Market 4 again and led to the concept of virtual unbundling. This wholesale product should incorporate as many functions of physical unbundling as possible while being suited to NGA infrastructures. The United Kingdom and Austria acted as pioneers for virtual unbundling. In the following chapter the situation in UK and Austria are analyzed.

2 Virtual unbundling in the UK and in Austria

2.1 United Kingdom – regulatory approach

The dichotomy between passive and active access products has been addressed in the context of delivering super-fast broadband in the UK by OFCOM. According to OFCOM there are two options for the promotion of competition in the access network (see also Figure 2):

- **active products** – wholesale services bought from super-fast broadband network owners that use both the network owners' physical infrastructure (such as copper cables, fibre or duct) and its electronic equipment; and
- **passive products** – where competitors buy access to the network owner's physical infrastructure only, and combine these with their own electronics to deliver services.

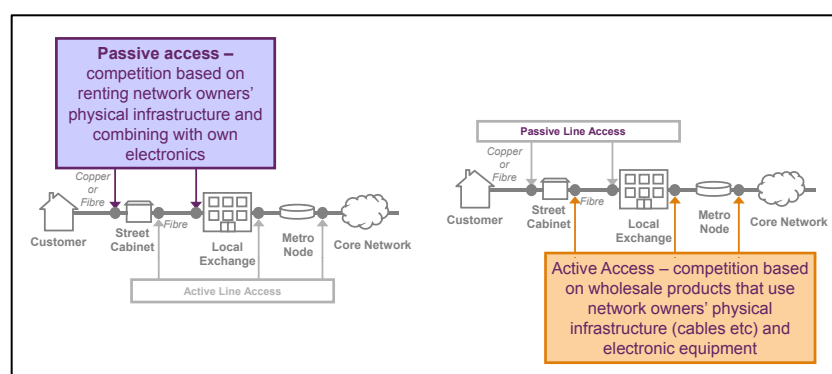

Figure 2: Ofcom Next Generation Competitive Broadband: From LLU to ALA⁶

⁶ Presentation by OFCOM, 2 March 2009; ALA ... Active Line Access

OFCOM states clearly in its statement "delivering super-fast broadband in the UK"⁷, that

"Active products will be fundamental to delivering widespread competition in super-fast broadband regardless of what happens with passives. They will form a vital part of the overall competitive environment and delivery of new retail services." The technical details of the right product to be provided by BT have been under discussion between the regulator and the industry for quite some time. The technical discussions are included in an accompanying document "Ethernet active line access: updated Technical requirements" [OFCOM 2009-2]. The aim is to "provide a wholesale bitstream access which, unlike previous forms of bitstream, offers Communications Providers (CPs) scope for innovation and retail product differentiation which is as close as possible to that allowable by passive infrastructure access."

In its analysis of the wholesale local access market, OFCOM has designated SMP status for BT in the local access market [OFCOM 2010].⁸ The relevant wholesale product market is defined for loop-, cable- and fibre-based local access at a fixed location. Access based on fixed wireless, mobile and satellite technologies are excluded. Specific remedies include LLU, subloop unbundling, physical infrastructure access (i.e. duct and pole access) and virtual unbundled local access (VULA). OFCOM emphasizes the important role of ULL, which has allowed the Communications Providers to compete with BT. OFCOM states:

"In fact, it [ULL] has been so effective that it has led us to find no SMP in the downstream WBA market in over 70 per cent of the UK".

Subloop unbundling has been retained as a remedy although the economics of SLU-based networks are challenging and uptake is low. OFCOM has not implemented a specific remedy for fibre access, fibre backhaul and rollout of multiple fibre as foreseen in the NGA recommendation.

Investment in NGA is addressed by two different remedies: Passive Infrastructure Access (PIA) and VULA. The physical infrastructure of deploying access networks is the most important cost factor and constitutes 50 to 70 percent of overall capital expenditure. OFCOM argues, that allowing BT's competitors to use BT's physical infrastructure (i.e. ducts and poles) would remove a significant barrier to infrastructure deployment.

The rollout of NGA networks is costly and OFCOM asserts that competition in NGA-based services, at least in the short time, may be best served by CPs sharing a single network. In areas where BT deploys a NGA network based on FTTP or FTTC it should be required to

⁷ OFCOM 2009-1

⁸ This concerns UK with the exception of Hull.

provide access to these networks. This access would be a form of non-physical (virtual) access, which would, as far as possible, replicate many of the features of a physical access remedy, such as LLU.

Virtual unbundling would lower the barrier for other Communications Providers to offer services based on NGA infrastructure since the costs for virtual unbundling are significantly lower than using physical access like subloop unbundling or PIA. Virtual unbundling should allow innovation and service differentiation and it should be offered as a raw service and CPs should be able to decide for themselves bandwidth, QoS, retail pricing and retail services. OFCOM points out five key characteristics for VULA:

- **Local access:** Interconnection should occur locally at the first feasible aggregation point.
- **Service agnostic access:** VULA like LLU should be a generic access product.
- **Uncontended access:** The connection, or capacity, between the consumers' premises and the local serving exchange where interconnection takes place should be dedicated to the end user, i.e., the connection should be uncontended. The availability of an uncontended access connection, alongside the control options discussed below, would ensure that the full innovation benefits can be realized.
- **Control of access:** CPs should have maximum flexibility in their ability to offer differentiated products to consumers and potentially to vary the QoS parameters.
- **Control of customer premises equipment:** Allowing CPs the freedom to choose CPE and provides the flexibility needed to ensure CPs ability to differentiate how they deliver services to their customers.

In the course of the consultation process, other stakeholders have added comments and several additional proposals have been discussed.

OFCOM has given BT room to maneuver in pricing. There is no obligation to offer cost oriented prices. Pricing should be fair and non-discriminatory. The competitive price control mechanisms remain and prices should be margin squeeze free.

2.2 Product implementation by BT

British Telecom has developed several Generic Ethernet Access (GEA) products. GEA-FTTP (Fibre to the premises) is based on PON technology in the access network (see Figure 3) and it is available with speed up to 100 Mbit/s downstream and up to 30 Mbit/s upstream.

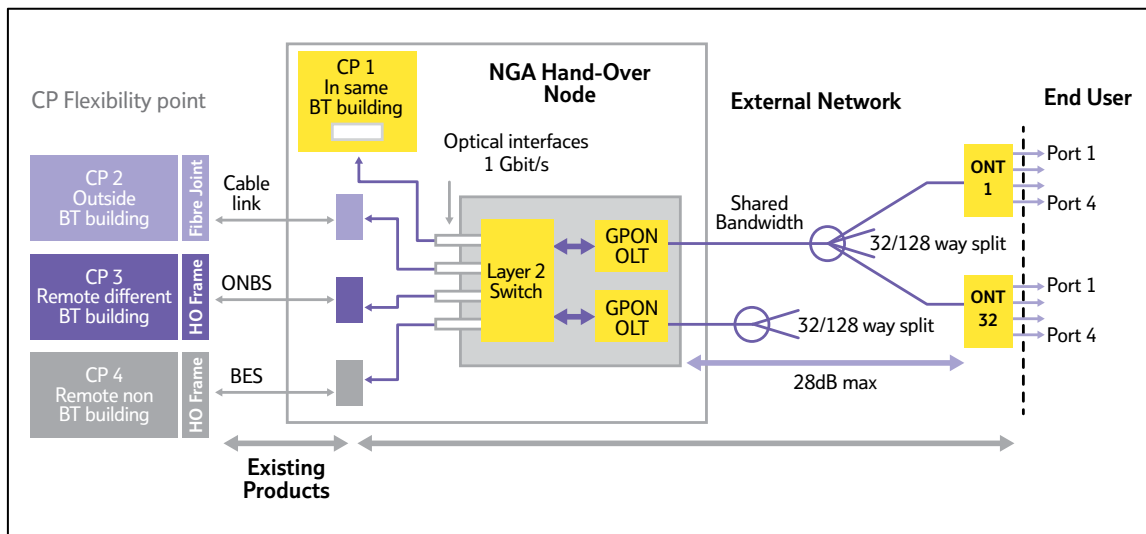

Figure 3: GEA over FTTP (source openreach)

GEA-FTTC is based on VDSL technology. Speeds are offered up to 80 Mbit/s downstream and up to 20 Mbit/s upstream. The downstream prioritised rate is 20 Mbit/s.

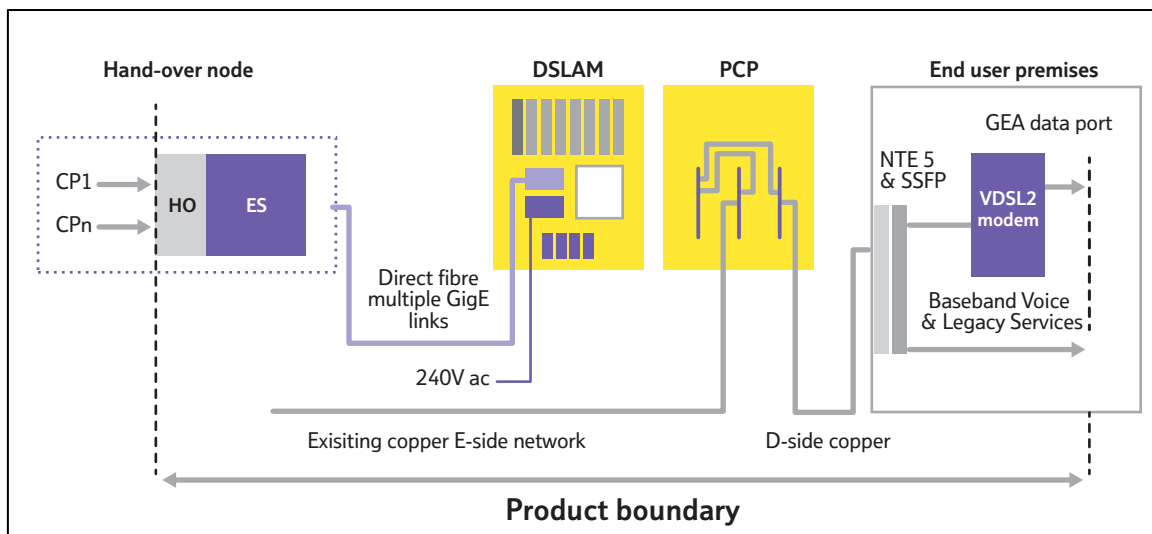

Figure 4: GEA over FTTC (source openreach)

Both products provide an „always on“ Virtual LAN (VLAN) between the Optical Line Termination (OLT) equipment in a BT exchange and each Optical Network Termination (ONT) device in the end user premises. BT differentiates for both products between peak rate and prioritized rate. The prioritized rate is available under congested conditions. In addition to these products GEA cablelink is required to connect CP's equipment.

Since these products form the basis for virtual unbundling it is worthwhile to check whether OFCOM's requirements are fulfilled.

- **Local access:** GEA products are situated between the customer and the local exchange. The requirement for local access seems to be fulfilled.
- **Service independent:** OFCOM argues that VULA should be made available as stand-alone service and not tied to other services.
- **Uncontended access:** GEA products provide uncontended access. BT however distinguishes between peak data rate and prioritized rate. The prioritized rate should be available under congested conditions.
- **Control of access:** BT offers three generic profiles, which provide a compromise between speed and stability.
- **Control of customer premises equipment:** CPs have argued that the network termination installed by BT should not include any active electronic elements (i.e. "wires only"). Thus, only one powered box would be needed at the customer premises. OFCOM has stated in the consultation document that standards are not sufficiently mature to allow "wires only" representation. A second point of discussion is whether BT is allowed to include an ATA in the network termination. CPs argued that this might lead to undue advantages for BT.

A final assessment whether BT's GEA products fulfill OFCOM's requirements is not available. A measure would be the actual take-up rate of GEA products and the effect on competition in the broadband market.

2.3 Austria – regulatory approach

The Austrian regulatory authority Telekom-Control-Kommission (TKK) has followed a similar path as OFCOM. In its statement about market analysis in Market 4 from 6 December 2010 the incumbent A1 Telekom Austria is designated SMP status and is required to offer the following wholesale products:

- unbundled local loop and subloop unbundling;
- collocation, access to ducts and dark fibre in the access network; and
- virtual unbundling

The wholesale product of virtual unbundling is required to provide eight key characteristics:

- Virtual unbundling should allow a similar degree of innovation as passive access (physical unbundling)
- Transparency of communications in higher layers; CPs should be able to replace ULL by virtual unbundling without changing the CPE.

- Multicast must be possible – either implemented as a feature of the wholesale offer or implemented by the CP
- Technological neutrality shall apply
- The CP should be able to choose the customer premises equipment from a white list issued by the incumbent operator.
- Interconnection should occur at the main distribution frame site or a similar point in the NGA.
- Handover of third party traffic shall be possible.
- Control of all relevant connection parameters by CPs or alternatively offering of uncontended bandwidth between customer and handover point.

In its reasoning TKK emphasizes that virtual unbundling should, as far as possible, resemble physical unbundling. It should be used in case physical unbundling is economically unfeasible. Virtual unbundling should provide a high degree of flexibility for the CP and allow for differentiating with regard to services and service features. This requires remote access to management and maintenance functions that are necessary for the design of the specific product (M3/09 p. 35). Alternatively, this degree of flexibility can be provided by the provision of uncontended bandwidth. However, A1 Telekom Austria is required to include to possibility of uncontended bandwidth in its offer.

2.4 Implementation by A1 Telekom Austria

A1 Telekom Austria pursues a demand driven NGA-rollout consisting of three parts:

- Targeted FTTH/FTTB roll-out in Vienna.
- FTTC roll-out in Vienna and surrounding areas, selected regional capitals and state funded roll-out in rural areas.
- FTTEEx roll-out across Austria (FTTEEx means fibre to the Exchange and means VDSL implementation within a circular area of about 1 km surrounding the exchange).

According to [Telekom Austria 2012] A1 Telekom Austria has achieved 52% addressable market at the end of 2011. The roll-out of services from street cabinets without mechanisms like PSD shaping lead to restriction of the use of ULL by other communications providers. A1 Telekom Austria has designed its virtual unbundling product (called VULA) as Ethernet VLAN connections between the customer premises and the CP [A1TA 2012]. On this line up to 4 VLANs, that can be used for different services, are supported.

The current offer is the result of ongoing discussions with the regulatory authority. The first offer was issued in April 2010 and has been refined twice. The offer is restricted to NGA deployment areas.

In contrast to the products offered by BT, the products include DSLAM Management as an additional component (Figure 5).

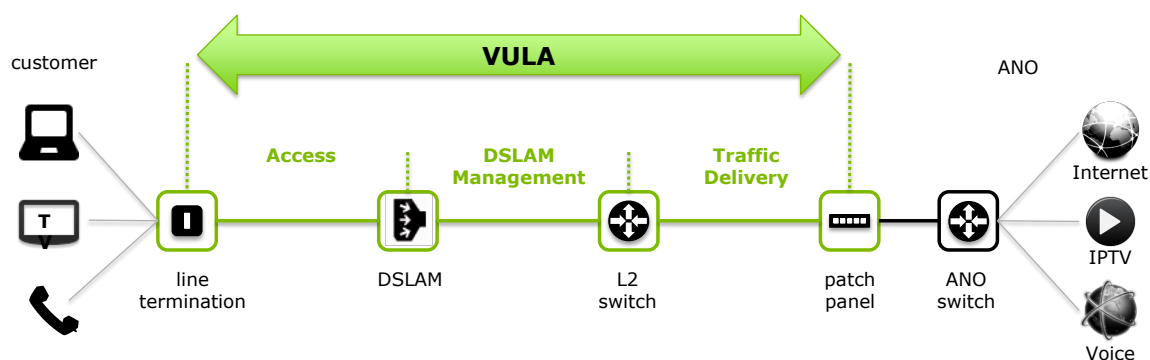

Figure 5: A1TA virtual unbundling product consists of three parts (source [A1TA 2012])

The three components of A1TA's virtual unbundling product are:

- **Access:** There are five profiles, which allow downlink data rates up to 100 Mbit/s.
- **DSLAM Management:** The bandwidth on the connection to the CP (DSLAM Management) can be purchased by the CP and is priced per Mbit/s. Within this bandwidth prioritization is possible. This allows the CP to choose the appropriate overbooking factor.
- **Traffic delivery:** The traffic delivery is a fibre optic link between A1TA's layer 2 switch and the handover point to the CP.

2.5 Comparison between regulation / implementation in Austria and UK

Although, the main goal of virtual unbundling in the UK and Austria is similar, there are a few notable differences in the key characteristics as required by the regulatory authority.

The most important difference seems to be the implementation of the requirement for uncontended bandwidth. OFCOM requires uncontended bandwidth as one of the key characteristics. Austrian's TTK requires control of connection parameters or alternatively uncontended bandwidth. These different requirements have led to different product implementations and also to different price structures.

Although, BT's GEA products offers uncontended bandwidth, a distinction is made between peak rate and prioritized rate. The virtual unbundling product offered by A1 Telekom Austria provides bandwidth on the link towards the CP as additional pricing element. This allows the CP to decide about overbooking factor. The key question is whether bandwidth-dependent pricing leads to a margin squeeze. The more bandwidth the CP requests, especially close to uncontended bandwidth, the higher the costs and the more likely the appearance of a price cost squeeze. It is further questionable whether control of connection parameters and uncontended bandwidth are interchangeable requirements. It can be argued, that the combination of these requirements into one of the key characteristics is useful and these features are independent, as OFCOM has stated.

The main requirement is that VULL should offer a similar degree of innovation as ULL. A CP has full control over a physically unbundled local loop and within the agreed upon deployment rules several services can be offered. BT's offer guarantees the prioritized rate for each customer. In order to achieve the same flexibility, wholesale customers of A1 Telekom Austria need to buy the bandwidth on the link between DSLAM and handover point to the CP (BT calls this part cablelink). From a functional point of view this can be done, however the pricing may represent an entry barrier.

In Austria and UK, various discussions between industry bodies and the regulatory authority have been held. A final assessment, whether the products offered by the incumbents fulfill the regulatory requirements is still outstanding. A critical element seems to be the pricing of the virtual unbundling products. Both regulatory authorities have refrained from price controls but required that prices should be margin squeeze free. The final verdict will be delivered by the communications providers, who are the addressees of virtual unbundling. If the uptake is too low and re-monopolisation seems likely, regulatory authorities will have to step in and further regulate the market. Virtual unbundling seems to be crucial for competitiveness in Next Generation access networks.

3 Analysis of virtual unbundling

3.1 Facilities-based competition

One of the main differences between the regulatory approach in the United States and in Europe is the assessment of facilities-based competition. Experts in both areas agree that facilities-based competition is preferable due to the higher sustainability. In the United States effective competition between cable TV, wireless networks and copper/fibre based access networks is assumed and the obligation of unbundling has been largely dropped. The access line is therefore no longer an essential facility. In most European countries the broadband markets are not deemed sufficiently competitive and SMP has been found during market analysis. This has led to a broad set of remedies with respect to SMP operators having to avail the access line for specific services.

There is also a difference in market definition. In Europe a “market” usually does not include wireless technologies. Since wireless is not seen as a substitute for broadband at a fixed location, the possible competitors are restricted to regional cable companies. Together with the perception that a rollout of more than one NGA infrastructure is economically unfeasible, it follows that only one NGA infrastructure can exist.

It must be assumed that technology is not the reason for the different approaches. Obviously, there are different assessments as to which extent the market will be able to supply broadband network infrastructure in the access part and whether or not there are companies that are able to compete against incumbent operators.

3.2 Virtual unbundling and bitstream access

A lengthy debate has been initiated with respect to the classification of virtual unbundling. Is virtual unbundling a substitute for physical unbundling and does thus belong to Market 4 (physical access) or is it a form of enhanced bitstream (Market 5)? This assessment is important as it implies which type of regulation can apply to virtual unbundling. Regulatory intervention still appears to be more intensive in the market for physical access due to the more inherent features of a market lacking competition.

The European Regulator's Group (ERG) states in its report on Next Generation Access⁹ that:

"The distinction between Market (4) (→ layer 1) and Market 5 (→ Layer 2, 3) as defined in the ERG CP NGA is considered clear and still valid even with the emergence of new bitstream products with more functionalities offering greater scope for innovation. As long as the substitutability gap remains these market should not be blurred in an NGA environment. In addition, in some countries a bitstream product with additional functionalities and diversification possibilities has already existed for some years. Where this has been the case and NRAs have conducted a market review, the NRAs have included this enhanced bitstream product in Market 5 as it does not provide the same flexibility as available with a Market 4 product because the access seeker depends on the technological choice of the SMP operator. This is true for all the different current types of bitstream services".

and

*"Finally, an important condition for phasing out MDF-access services is the availability of an alternative wholesale product which allows for the continuation of sustainable competition. According to the ladder of investment, **a passive wholesale product is preferred over an active wholesale product**. In this sense, duct access – imposed by some NRAs and also considered in the draft NGA EC Recommendation – is, like unbundling, a remedy that encourages infrastructure based competition. However, in situations/areas where passive remedies (alone) do not represent a viable alternative and are not enough to address the competition problems, they should be complemented with active remedies such as enhanced bitstream services that provide additional functionality" [Emphasis added]*

The NGA recommendation makes a distinction between the types of access delivered by Market 4 and Market 5 and states in Recital (20):

"Alternative operators, some of whom have already deployed their own networks to connect to the unbundled copper loop of the SMP operator, need to be provided with appropriate access products in order to continue to compete in an NGA context. For FTTH these may consist of access to civil engineering infrastructure, to the terminating segment, to the unbundled fibre loop (including dark fibre) or of wholesale broadband access, as the case may be. Where remedies imposed on Market 4 lead to effective competition in the corresponding downstream market, in the whole market or in certain geographic areas, other remedies could be withdrawn in the market or areas concerned. Such withdrawal would be indicated, for instance, if the successful imposition of physical access remedies were to render additional bitstream remedies redundant. Moreover, in exceptional circumstances, NRAs could refrain from imposing unbundled access to the fibre loop in geographic areas where the presence of several alternative infrastructures, such as FTTH networks and/or cable, in combination with competitive access offers on the basis of unbundling, is likely to result in effective competition on the downstream level."

⁹ ERG, 2009

Successful remedies in Market 4 could therefore lead to a withdrawal of remedies in the corresponding downstream markets.

The NGA recommendation also recognizes possible difficulties in implementing unbundling for point to multipoint architectures and require that

"... NRAs should be able to adopt measures for a transitional period mandating alternative access products which offer the nearest equivalent constituting a substitute to physical unbundling, provided that these are accompanied by the most appropriate safeguards to ensure equivalence of access and effective competition. In any event, NRAs should in such cases mandate physical unbundling as soon as technically and commercially feasible."

Most regulatory authorities place enhanced bitstream access in Market 5 (Spain, Italy, Germany, Ireland). In UK and Austria virtual unbundling is designated a remedy in Market 4.¹⁰

3.3 Does virtual unbundling contribute to investment in NGA?

Virtual unbundling implies a massive change in the local access market as the established model of physical unbundling may lose in importance. Physical unbundling was created for the copper world but in times of increasing bandwidth demand, copper unbundling may reach its limit. Therefore, technologies that are capable of carrying more bandwidth will prevail. This automatically brings an advantage to those who invest first in next generation access networks. In many cases this will be the incumbent operator. In such a case virtual unbundling may be nothing but an attempt to safeguard the achieved status of competition in the copper world and transform it to the "fibre world". However, the migration process and the lack of economies of scale for alternative operators can become a substantial problem.

One could ask whether virtual unbundling has an impact on investment. At first sight, one could assume so, because a remedy would already be in place, before the networks are widely established. On the other hand, incumbents could be motivated to invest into NGA because the new business models are disruptive and thus could also negatively impact the achieved competition which may result in a competitive advantage for the incumbent operators.

¹⁰ ComReg 2012

3.4 What is the influence of virtual unbundling on broadband markets?

It is too early to empirically determine the influence of virtual unbundling. There are several factors determining the success of wholesale offers and with regard to virtual unbundling, some of the factors include:

- The success of alternative technologies such as wireless technologies. In section 3.1 it was stated that wireless and cable networks are viable alternatives to provide broadband services. Hence, if these technologies develop and offer similar product characteristics (e.g. bandwidth) at similar conditions, virtual unbundling will ceteris paribus be less successful.
- The bandwidth offered in case of virtual unbundling relies on the NGA deployment of the regulated operators. If the regulated operators implement fibre to the building or fibre to the home instead of fibre to the cabinet, the bandwidth will be higher and the virtual unbundling more attractive to the end users. On the other hand FTTB and FTTH might offer the opportunity to implement physical unbundling of fibres.
- The end user demand for higher bandwidths and their willingness to pay is still an issue for discussion. On the one hand the bandwidth demand has increased over time from 56 kbit/s as a kind of “data access standard” in the 1990s, which implies that higher bandwidths and therefore virtual unbundling will be interesting as a wholesale offer to telecom operators. On the other hand, if the costs of the virtual unbundling are too high, the providers (access seekers) will not be able to provide commercially successful end user offers based on virtual unbundling.
- With respect to the competition approach in various countries virtual unbundling of next generation access infrastructures may finally limit the facility-based competition and foster the service-based competition because operators are using only one infrastructure provided.

These factors influence the demand from CPs and also the regulatory approach of the NRAs for virtual unbundling.

Another way to analyze the influence is to look at the intermodal competition effects. If virtual unbundling is not implemented as a wholesale offer (or implemented with unattractive conditions), while at the same time the regulated operators roll out NGA networks and thereby limit the availability of copper loop unbundling, intensity of competition will decrease. If though no roll-out is taking place, there will be no change to the current competition situation. Hence, the following degree of influence from virtual unbundling can be concluded:

End user demand		No	No	High
Virtual unbundling		No	Yes	Yes
Competition from wireless, cable and non-regulated fibre networks	Low	no influence	no influence	Significant influence on intermodal competition and eventually on the success of the NGA implementation.
	High	no influence	no influence	Potential influence on inter- and intramodal competition and success of the NGA implementation

Table 1: intermodal competition effects

4 Summary

As it seems today, virtual unbundling may be one of the few options to maintain competition in case of a successful NGA rollout. With massive NGA investment, a higher usage of online and internet access is also implying greater speed needs of users for access. Therefore, staying outside is practically no option. On the other hand, virtual unbundling does not offer a guarantee that alternative operators can fully participate in the merits of NGA rollout. It is a complex solution and again a new wholesale product where alternative operators and providers have to get used to new processes and potentially invest effort in migrating existing customers. This assessment implies that the attractive route to go is difficult to find.

Virtual unbundling is a compromise between active and passive access products in the case of a FTTC rollout by the regulated operator. Experience in various European countries has shown that it is difficult to find the right product and pricing. The process in Austria and UK, whose regulatory authorities have chosen to levy the remedy of virtual unbundling has led to various refinements of the incumbent's product. In order to become successful, the specification of virtual unbundling needs to be stable and reliable as a basis for competition in next generation access networks.

It remains an open question whether virtual unbundling constitutes an intermediate step towards physical unbundling of the local loop or an enduring regulatory solution. The authors of this study consider virtual unbundling, if successful, as a rather long term solution. Again this depends on market demand and on the flexibility of the products to adapt to changing requirements.

Finally, the authors conclude that in order to become successful, virtual unbundling would need to fulfill the following high level requirements:

- **Technology independent:** Virtual unbundling must not depend on the technology used by the incumbent.
- **Stability:** Virtual unbundling from a technical point of view needs to be stable to secure investment decisions by CP.
- **Reasonably priced:** The pricing of virtual unbundling should on one hand offer enough incentives for the incumbent to roll-out NGA infrastructure. On the other hand, the pricing must allow for the CP to offer competitive and innovative retail products.
- **Flexibility:** Virtual unbundling must be flexible enough to be adapted to various changes in demand and service requirements.

The accomplishment of all these requirements is an ongoing process and the authors think that still more time is required to assess the final outcome. The process is further complicated by intermodal competition, which could provide competition on a deeper level and make virtual unbundling superfluous. However, time is a critical factor due to the fact that operators intensify NGA rollout. If this is left unregulated, investors get an advantage that competitors can hardly manage to keep up with. In the case of the NGA rollout new solutions on the wholesale level are needed as physical copper unbundling will come to an end. If this is not managed satisfactorily by regulatory authorities there is a de facto risk of monopoly to be established in the fixed access network.

5 References

- [A1TA 2012]: Virtual unbundled local access; the Austrian example. Presentation by Ing. Martin Merka at TNO DSL Seminar 2012, Leiden, The Netherlands, 4. June 2012,
- [BT 2010]: SIN 506: Fibre to the premises generic ethernet access; service and interface description. Issue 1, October 2010.

[BT 2012]: SIN 498: Fibre to the cabinet Generic Ethernet Access; service and interface description. Issue 3.3, February 2012.

[ComReg 2012]: Next Generation Access: Proposed remedies for Next Generation Access Markets. ComReg 12/27, 04/04/2012.

[EC 2007] Commission Recommendation of 17 December 2007 on relevant product and service markets within the electronic communications sector susceptible to ex ante regulation in accordance with Directive 2002/21/EC of the European Parliament and of the Council on a common regulatory framework for electronic communications networks and services.

[EC 2010] European Commission recommendation on regulated access to Next Generation Access Networks (NGA), 20 September 2010

[ERG 2007] ERG (European Regulators Group) (2007), ERG Opinion on Regulatory Principles of NGA, ERG (07) 16rev2

[ERG 2009]: Report on Next Generation Access – Economic Analysis and Regulatory Principles. ERG (09)17, June 2009.

[OFCOM 2009-1]: Delivering super-fast broadband in the UK. Promoting investment and competition. Statement from 3. March 2009.

[OFCOM 2009-2]: Ethernet Active Line Access: Updated technical requirements. Discussion document from 3. March 2009.

[OFCOM 2010-1]: Review of the wholesale local access market; Consultation on market definition, market power determinations and remedies, 23 March 2010

[OFCOM 2010-2]: Review of the Wholesale local access market. Statement on market definition, market power, determinations and remedies. Statement from 7 October 2010.

[OfCOM 2010-3]: Enabling a super-fast broadband Britain, see <http://media.ofcom.org.uk/2010/03/23/enabling-a-super-fast-broadband-britain/> (with further references)

[RTR 2009]: Decision on physical access to infrastructures (decision M3/09), see
http://www.rtr.at/de/tk/M_3_09/M_3_09_103_Bescheid.pdf

[Ruhle and Lundborg 2010], Ruhle E-O. and Lundborg M, EU policy for next generation access – an innovative or incremental step forward?, Telecommunications Policy 34 (2010) 36-44

[Telekom Austria 2012]: Results of the Fourth Quarter and Full Year 2011. Telekom Austria Group. Vienna, 23 February 2012.

[Vogelsang, 2005] Interview with Prof. Ingo Vogelsang, Professor of Economics, Boston University, Communications & Strategies 57, 03/2005