

Tochtermann, Klaus (Ed.); Maurer, Hermann (Ed.); Kappe, Frank (Ed.); Haas, Werner (Ed.)

**Proceedings — Published Version**

## I-KNOW '08 and I-MEDIA '08: International conferences on knowledge management and new media technology

*Suggested Citation:* Tochtermann, Klaus (Ed.); Maurer, Hermann (Ed.); Kappe, Frank (Ed.); Haas, Werner (Ed.) (2008) : I-KNOW '08 and I-MEDIA '08: International conferences on knowledge management and new media technology, Verlag der Technischen Universität Graz, Graz

This Version is available at:

<https://hdl.handle.net/10419/44443>

**Standard-Nutzungsbedingungen:**

Die Dokumente auf EconStor dürfen zu eigenen wissenschaftlichen Zwecken und zum Privatgebrauch gespeichert und kopiert werden.

Sie dürfen die Dokumente nicht für öffentliche oder kommerzielle Zwecke vervielfältigen, öffentlich ausstellen, öffentlich zugänglich machen, vertreiben oder anderweitig nutzen.

Sofern die Verfasser die Dokumente unter Open-Content-Lizenzen (insbesondere CC-Lizenzen) zur Verfügung gestellt haben sollten, gelten abweichend von diesen Nutzungsbedingungen die in der dort genannten Lizenz gewährten Nutzungsrechte.

**Terms of use:**

*Documents in EconStor may be saved and copied for your personal and scholarly purposes.*

*You are not to copy documents for public or commercial purposes, to exhibit the documents publicly, to make them publicly available on the internet, or to distribute or otherwise use the documents in public.*

*If the documents have been made available under an Open Content Licence (especially Creative Commons Licences), you may exercise further usage rights as specified in the indicated licence.*

# I-KNOW '08 and I-MEDIA '08

## International Conferences on Knowledge Management and New Media Technology

<b>Preface</b>	1
K. Tochtermann, H. Maurer, F. Kappe, W. Haas	
<b>Wikis in Global Businesses</b>	6
P. Kemper	
<b>Managing Knowledge that Everybody Knows Already</b>	7
H. Lieberman	
<b>Humans and the Web of Data</b>	8
T. Heath	
<b>Commercialization of Semantic Technologies in Malaysia</b>	9
D. Lukose	

## *Scientific Track*

### *Knowledge Management*

- Emergent Innovation—a Socio-Epistemological Innovation Technology** 11  
M. Peschl, T. Fundneider
- Challenge Knowledge Valuation** 19  
H. Schorcht, V. Nissen
- Analyzing Organizational Information Gaps** 28  
H.-J. Happel, L. Stojanovic

### *Knowledge Management Applied*

- Towards Continuous Integration of Knowledge Management into Game Development** 37  
S. Lohmann, J. Niesenhaus
- Success and Failure Factors for KM: The Utilization of Knowledge in the Swedish Armed Forces** 45  
U. Pettersson
- Knowledge Barriers in CD&E Projects in the German Federal Armed Forces** 53  
E.-M. Kern, M. Koch, C. Fiechter, A. Richter

### *Knowledge Work*

- Regards about Virtual Knowledge Work** 61  
M. Muntean, I. Hauer
- More Productive Knowledge Work** 68  
S. Eschenbach, B. Schauer
- A Model for Document Processing in Semantic Desktop Systems** 76  
O. Leifler, H. Eriksson

### *Learning and User Modelling*

- Knowledge Building and Competence Development in eLearning 2.0 Systems** 84  
M. Ivanova
- Improving Recommendations by Using Personality Traits in User Profiles** 92  
M. A. S. N . Nunes, S. A. Cerri, N. Blanc
- Applying Adaptive Collaborative Management for Social Learning: A Case Study of Community Forestry in Nepal** 101  
C. Khadka, H. Vacik

<i>User Context and User Profiles</i>	
<b>KAJAL – An Algorithm for Workflow Navigation in Informal Learning</b>	109
E. Godehardt, M. Doehring, A. Faatz, M. Goertz	
<b>Extending Low Level Context Events by Data Aggregation</b>	118
R. Lokaiczny, M. Goertz	
<i>Knowledge Transfer and Sharing</i>	
<b>A Model for Context-Sensitive Transfer of Expertise</b>	126
B. Mayr, R. Born	
<b>Collaboration Patterns for Knowledge Sharing and Integration in Second Life: A Classification of Virtual 3D Group Interaction Scripts</b>	134
A. Schmeil, M. Eppler	
<b>The Leap to Knowledge Management for Universities in Developing Economies</b>	142
C. Cucu, M. Ristoiu	
<i>Social Software</i>	
<b>Growth and Sustainability in Online Social Networks</b>	150
G. Ossimitz, C. Russ	
<b>Dynamic Network Analysis of Wikis</b>	161
R. Klamma, C. Haasler	
<b>Getting to “Know” People on the Web 2.0</b>	169
Y. Cao, A. Glukhova, R. Klamma, Z. Petrushyna	
<i>Social Software Applied</i>	
<b>Knowledge Sharing with Social Software - Wikis in Human Services</b>	177
K. Bredl	
<b>Web 2.0 Adoption by Danish Newspapers - Urgent Need for New Business Models?</b>	185
N. Bjørn-Andersen, L. B. Rasmussen, S. Rasmussen	
<b>Developing an User-Centred Project Involving the Web 2.0 Community: a Case Study Based on Video Sharing Websites (<a href="http://e-guitar.univ-reunion.fr/">http://e-guitar.univ-reunion.fr/</a>)</b>	194
O. Sebastien, N. Conruyt	
<i>Social Web Technologies</i>	
<b>Aggregation and Personalization of Infotainment – An Architecture Illustrated with a Collaborative Scenario</b>	202
S. Turlier, B. Huet, T. Helbig, H.-J. Vögel	

<b>ActiveTM - The Factory for Domain-customised Portal Engines</b>	210
L. Maicher, B. Bock	
<i>Multimedia Metadata and Web 2.0</i>	
<b>Non-linear Story-telling in a Mobile World</b>	218
R. Klamma, Y. Cao, A. Glukhova, A. Hahne, D. Renzel	
<b>Providing Multi Source Tag Recommendations in a Social Resource Sharing Platform</b>	226
M. Memmel, M. Kockler, R. Schirru	
<i>New Media Technologies</i>	
<b>What's the Power behind 2D Barcodes? Are they the Foundation of the Revival of Print Media?</b>	234
P. Schmidmayr, M. Ebner, F. Kappe	
<b>Building Tagged Linguistic Unit Databases for Sentiment Detection</b>	243
A. Scharl, A. Weichselbraun, S. Gindl	
<i>Semantic Technologies</i>	
<b>Using Domain Knowledge Provided by Ontologies for Improving Data Quality Management</b>	251
S. Brüggemann, F. Grüning	
<b>A Knowledge-based Solution for Core Competence Evaluation in Human-Capital Intensive Companies</b>	259
S. Colucci, E. Di Sciascio, F. M. Donini	
<b>Proposing a Framework for Frequently used Terms in Knowledge Management</b>	267
A. Hoffmann	

*Intelligent Assistance for Self-Directed and  
Organizational Learning*

<b>Introduction</b>	276
E. Ras, M. Memmel, T. Ley, S. Lindstaedt, D. Albert	
<b>Management of Situated E-learning in Organizations</b>	280
L. Zenk, R. Pircher, E. Mayr, H. Risku	
<b>Visualisation Tools for Supporting Self-Regulated Learning through Exploiting Competence Structures</b>	288
A. Nussbaumer, C. Steiner, D. Albert	
<b>Story Management Technologies for Organizational Learning</b>	296
A. Gordon	
<b>Learner-Generated Annotation of Learning Resources - Lessons from Experiments on Tagging</b>	304
S. Lohmann, S. Thalmann, A. Harrer, R. Maier	

*Knowledge Visualization and Knowledge Relationship  
Discovery*

<b>Introduction</b>	313
M. Granitzer, V. Sabol, W. Kienreich, H. Bischof	
<b>Do Visualizations Foster Experience Sharing and Retention in Groups? Towards an Experimental Validation</b>	316
S. Bresciani, M. Eppler	
<b>Handling the Complexity of RDF Data: Combining List and Graph Visualization</b>	324
P. Heim, J. Ziegler	
<b>Semantic Search and Visualization of Time-Series Data</b>	332
T. Tekusova, V. Voss, J. Kohlhammer	
<b>Understanding Interlinked Data - Visualising, Exploring and Analysing Ontologies</b>	341
O. Noppens, T. Liebig	
<b>Visual Assessment of Heritage Architecture Life Cycles</b>	349
I. Dudek, J.-Y. Blaise	
<b>Weighted Experts: A Solution for the Spock Data Mining Challenge</b>	358
B. Stein, S. Meyer Zu Eissen	

## *Knowledge Services*

<b>Introduction</b>	366
S. Lindstaedt, R. Maier, V. Pammer, P. Scheir, N. Weber	
<b>Conceptual Foundations for a Service-Oriented Knowledge &amp; Learning Architecture: Supporting Content, Process, and Ontology Maturing</b>	369
A. Schmidt, K. Hinkelmann, S. Lindstaedt, T. Ley, R. Maier, U. Riss	
<b>Information Retrieval Services for Heterogeneous Information Spaces</b>	378
J. Bahrs, B. Meuthrath, K. Peters	
<b>Semantic Task Management Framework</b>	387
E. Ong, U. Riss, O. Grebner, Y. Du	
<b>The BREIN-Roadmap with PROMOTE: A Use-Case Scenario of a Service-Based Knowledge Management Approach</b>	395
R. Woitsch, A. Leutgeb	



## *Knowledge Acquisition from the Social Web*

<b>Introduction</b>	403
A. Hotho, M. Lux, S. Sizov, M. Strohmaier	
<b>Mining Socio-Semantic Networks Using Spreading Activation Technique</b>	405
A. Troussov, M. Sogrin, J. Judge, D. Botvich	
<b>Visualizing Dynamics in Virtual Information Spaces</b>	413
C. Müller, S. Kroeger	
<b>Envisioning With Weblogs</b>	421
A. Gordon, R. Swanson	
<b>Using Visual Features to Improve Tag Suggestions in Image Sharing Sites</b>	425
M. Lux, O. Marques, A. Pitman	
<b>Harnessing Wikipedia for Smart Tags Clustering</b>	430
M. Grineva, M. Grinev, D. Turdakov, P. Velikhov, A. Boldakov	

### *Short Papers*

<b>Becoming Knowledge Focused: Towards a Conceptual Definition of Knowledge Management in International Organizations</b>	432
U. Ugbor	
<b>Expertise Finding for an Electronic Journal</b>	436
M. T. Afzal, N. Kulathuramaiyer, H. Maurer	
<b>Query Log Analysis for User-Centric Multimedia Databases</b>	441
L. Limam, L. Brunie, D. Coquil, H. Kosch	
<b>Social Software Strategies for Educational Technology Thematic Portals</b>	445
R. Ovelar, M. Benito	
<b>Strategy maps – A tool for Strategic Management with High Impact on Organisational Knowledge Creation and Integration</b>	449
K. Valentin, M. Augl	
<b>The TUGLL Plug-ins: Special Needs for a University Wide Blogosphere</b>	453
M. Ebner, B. Taraghi, W. Nagler	



# **I-KNOW '08 and I-MEDIA '08**

## **International Conferences on Knowledge Management and New Media Technology**

### **Preface**

Since its inception in 2001, I-KNOW, the International Conference on Knowledge Management, has been developed to be one of the leading application-oriented conferences on IT-based Knowledge Management in Europe. This year the Know-Center, Austria's competence center for knowledge management, organizes I-KNOW for the eighth time. I-KNOW'08 addresses newest scientific developments in the field, including latest results in Knowledge Services and Knowledge Relationship Discovery, both within the context of Knowledge Work.

I-MEDIA which is held for the second time is co-organized by Know-Center, Graz University of Technology and Joanneum Research. It has its focus on New Media Technologies, dealing with topics such as Web 2.0 and Multimedia Metadata, always within the context of Knowledge Management or Semantic Technologies.

The organizers are proud to attract again about 450 participants. This high number is the best indicator that the conference series and the selected topics are well accepted not only by the scientific community but also by our participants from industry and public organizations. They all will be offered with a high quality program addressing most recent advancements in knowledge management and new media technology. These advancements are reflected in 52 full papers and 6 short papers which have been selected for publication by our program committee. This corresponds to an acceptance rate of 42% for full papers.

The scientific program is structured as follows. Special tracks allow thematically focused scientific communities to exchange ideas and results among each other in a one day in-depth discourse. The special tracks cover the following fields.

- Knowledge Services
- Visualization and Knowledge Relationship Discovery
- Self-Directed and Organizational Learning
- Knowledge Acquisition from the Social Web

In addition to these special tracks the accepted papers address among others topics

- User Context and User Profile
- Knowledge Work
- Multimedia Metadata and Web 2.0
- Knowledge Transfer and Knowledge Sharing
- Learning and User Modelling
- Applications of Social Media and Knowledge Management

Many thanks go to all authors who submitted their papers and of course to our international program committee for their careful reviews. The contributions which have been selected by the program committee are published in these proceedings. Revised versions of the best of these contributions will also appear in our electronic journal J.UCS ([www.jucs.org](http://www.jucs.org)), Section Knowledge Management. J.UCS supports the open access initiative for scientific literature and thus ensures the knowledge transfer and dissemination towards the community.

It is our conference strategy not only to provide high quality presentations but also to function as a platform for networking. Deliberately long breaks and social events in the evenings are excellent opportunities for meeting and networking with researchers or practitioners from all over the world. In addition, we will offer an international cooperation event which serves only the purpose of fostering networking among researchers and between researchers and practitioners.

Our four invited and internationally renowned keynote speakers are a further special highlight of the program. We are grateful that Henry Liebermann (MIT, USA), Peter Kemper (SHELL, Netherlands), Tom Heath (TALIS, United Kingdom), and Dickson Lukose (MIMOS, Malaysia) accepted our invitation to share their ideas about Common Sense Knowledge, Social Software, Semantic Web and Technologies with our participants.

We also would like to thank our sponsors: insiders GmbH, TopQuadrant Inc., Go International, and Punkt. netServices. Special thanks also go to Dana Kaiser who prepared the conference proceedings in time and in highest quality. Finally, we also would like to thank the core group at Know-Center who is responsible for the entire successful organization of the event. This core group includes (in alphabetical order) Anke Beckmann, Gisela Granitzer, Patrick Höfler, Alexander Stocker and Anita Wutte – Thank you for your continuous high motivation in organizing I-KNOW and I-MEDIA!

We are convinced that this year's conferences will be a terrific event and we hope that the conference in Graz will provide you with new ideas for your research and with new opportunities for partnerships with other research groups.

Sincerely yours,

Klaus Tochtermann, Hermann Maurer  
Conference Chairs I-KNOW

Hermann Maurer, Frank Kappe, Werner Haas and Klaus Tochtermann  
Conference Chairs I-MEDIA

Graz, August 2008

**Program Committee I-KNOW '08**

- Albert Dietrich, University of Graz, Austria
- Böhm Karsten, FH Kufstein Tirol, Austria
- Bonifacio Matteo, DISA - University of Trento, Italy
- Dreher Heinz, Curtin University of Technology, Australia
- Duval Erik, University of Leuven, Belgium
- Eppler Martin, University of Lugano, Switzerland
- Filipe Joaquim, School of Technology of Setubal, Portugal
- Kiryakov Atanas, Ontotex Lab, Sirma Group, Bulgaria
- Lehner Franz, University of Passau, Germany
- Li Sheng-Tun, National Cheng-Kung University, Taiwan
- Lukose Dickson, MIMOS, Malaysia
- Maier Ronald, University of Innsbruck, Austria
- Meersman Robert, Free University of Brussels, Belgium
- Naeve Ambjörn, Royal Institute of Technology, Stockholm, Sweden
- Nejdil Wolfgang, L3S and University of Hannover, Germany
- Pitner Tomas, Masaryk University of Brno, Czek Republic
- Rittberger Marc, DIPF - German Institute for International Educational Research, Germany
- Sabater Ramon, University of Murcia, Spain
- Schneider Kurt, University of Hannover, Germany
- Schneider Ursula, University of Graz, Austria
- Studer Rudi, University of Karlsruhe, Germany
- Thomas Jim, Pacific Northwest National Laboratory, USA
- Tolksdorf Robert, Free University of Berlin, Germany
- Tomek Ivan, Acadia University, Nova Scotia, Canada
- Tzarakis Manolis, University of Patras, Greece

**Program Committee I-MEDIA '08**

- Avrithis Yannis, NTUA/ITI, Greece
- Becker Thomas, Buhl Data Service, Germany
- Boeszoermyeni Laszlo, University of Klagenfurt, Austria
- Boll Susanne, University Oldenburg, Germany
- Chang Elizabeth, Curtin University of Technology, Australia
- Deussen Peter, University of Karlsruhe, Germany
- Dispert Helmut, Kiel University of Applied Sciences, Germany
- Güntner Georg, New Media Lab, Austria
- Haas Werner, Joanneum Research, Austria
- Hasebrook Joachim, Wissenschaftliche Hochschule Lahr, Germany
- Heuer Jörg, Siemens Corporate Technologies, Germany
- Hobson Paola, Motorola, United Kingdom
- Huang Qiang, The Open University, United Kingdom
- Kappe Frank, TU Graz, Austria
- Klamma Ralf, RWTH Aachen University, Germany
- Kollias Stefanos, NTUA, Greece
- Kompatsiaris Yannis, NTUA, Greece
- Kosch Harald, University of Passau, Germany
- Liu Wei, University of Western Australia, Australia
- Mansell Robin, London School of Economics, United Kingdom
- Murphy Jamie, University of Western Australia, Australia
- Nake Frieder, University of Bremen, Germany
- Reeves Thomas C., University of Georgia, USA
- Rhode Markus, University of Siegen, Germany
- Rudert Carl Marcus, Oneview Ges m b H Köln, Germany
- Scharl Arno, Modul University Vienna, Austria
- Scott Peter, Open University, United Kingdom
- Stanchev Peter, Kettering University, USA
- Smith Marc, Microsoft Research, USA
- Tochtermann Klaus, Know-Center & TU Graz Austria
- Wolpers Martin, KU Leuven, Belgium
- Wulf Volker, University of Siegen, Germany
- Troncy Raphael, CWI, Netherlands
- Westbomke Jörg, HDM Stuttgart, Germany

### **Additional Reviewers**

- Blee Ingo, Deutsches Institut für Internationale Pädagogische Forschung, Germany
- Carstens Carola, Deutsches Institut für Internationale Pädagogische Forschung, Germany
- Chang Won-Chen, National Cheng-Kung University, Taiwan
- De Leenheer Pieter, Semantics Technology & Applications Research Laboratory, Belgium
- Fischer Reinhard, MODUL University Vienna, Austria
- Heiko Haller, University of Karlsruhe, Germany
- Cord Hockemeyer, University of Graz, Austria
- Kickmeier-Rust Michael D., University of Graz, Austria
- Költringer Clemens, MODUL University Vienna, Austria
- Kuo Shu-Ching, National Cheng-Kung University, Taiwan
- Liapis Aggelos, Free University of Brussels, Belgium
- Lefrere Paul, The Open University, United Kingdom
- Mylonas Phivos, NTUA, Greece
- Reichling Tim, University of Siegen, Germany
- Schindler Christoph, Deutsches Institut für Internationale Pädagogische Forschung, Germany
- Schmidt Andreas, University of Karlsruhe, Germany
- Steiner Christina, University of Graz, Austria
- Stern Hermann, Graz University of Technology, Austria
- Tang Yan, Free University of Brussels, Belgium
- Thanh Tran, University of Karlsruhe, Germany
- Trog Damien, Free University of Brussels, Belgium
- Tsai Fu-Ching, National Cheng-Kung University, Taiwan
- Tsai Ming-Hong, National Cheng-Kung University, Taiwan
- Völkel Max, University of Karlsruhe, Germany
- Wiesauer Andreas, Johannes Kepler University Linz, Austria
- Zadeh Mohammad Reza Beik, MIMOS, Malaysia



## **Wikis in Global Businesses**

### **Keynote Speaker**

#### **Peter Kemper**

(SHELL International, Netherlands  
peter.kemper@shell.com)

In his talk Peter Kemper outlines the use of emerging Web 2.0 Technologies in a multi-national enterprise environment. Shell's internal Wiki - having over 40.000 users - demonstrates the success of Wiki Technology in a corporate setting. Fully integrated into Shell's information landscape, it fosters a central anchor point for technical, business and scientific knowledge in Shell. This central pool of knowledge offers new ways of information management for Shell's employees and establishes a platform for new innovative services like for example automatic linking of documents. Shell's Wiki cultivates collaboration and knowledge work across national borders - making knowledge transfer globally happening. Peter Kemper will point out the details of this 2.5 year old success story and will share his experience in deploying Web 2.0 technologies in Enterprises in this talk

### **About Peter Kemper**

Peter Kemper works since 1982 in Information Technology within Shell. After his Bachelor degree from the Rotterdam Nautical College he sailed as a Ship's Officer on both passenger ships as well as VLCC's (Very Large Crude Carriers). In 1981 he followed the internal Shell Informatics Education with BSO (now ATOS Origin). He worked in several different Shell companies (Nederlandse Aardolie Maatschappij, Pernis Refinery, Shell Nederland and Shell Exploration & Production) and his current work is within the Knowledge, Innovation & Design team of Shell International as Knowledge Management portfolio manager. Current projects are the Shell Wiki and several innovation projects to Virtual Worlds and Information Similarity Checking.

## **Managing Knowledge that Everybody Knows**

### **Keynote Speaker**

**Henry Lieberman**

(MIT, USA)

lieber@media.mit.edu)

Traditional knowledge management is focused on representing knowledge that is special in some way: unique to a person or group; technical or specialized knowledge; specific situation-dependent data about people, things or events. What everybody forgets is that that specialized knowledge builds on a base of Commonsense knowledge -- simple, shared knowledge about everyday life activities. A database might represent an airline flight with airline name, flight number, origin and destination time and place, etc. But no database represents the fact that if you travelling less than a kilometer, you can walk; if you are travelling thousands of kilometers, you probably need to fly. Why bother to represent this obvious knowledge explicitly, since everybody knows these things already? Because computers don't. If we would like to have computers be helpful to people, avoid stupid mistakes, and make reasonable default guesses about what people might want, they have to have Commonsense knowledge. I will present Open Mind Common Sense, a project to collect human Commonsense knowledge; ConceptNet, its semantic representation; and AnalogySpace, a new reasoning technique that draws plausible inferences, despite the fact that our knowledge base is incomplete, imprecise, and inconsistent.

### **About Henry Lieberman**

Henry Lieberman has been a Research Scientist at the MIT Media Laboratory since 1987. His interests are in the intersection of artificial intelligence and the human interface. He directs the Software Agents group, which is concerned with making intelligent software that provides assistance to users in interactive interfaces.

## **Humans and the Web of Data**

### **Keynote Speaker**

#### **Tom Heath**

(TALIS, United Kingdom  
tom.heath@talism.com)

How will the availability of linked, machine-readable data change the way humans interact with the Web, and what role can existing social processes play in supporting this interaction? In contrast to the conventional Web, in which documents are designed primarily for human consumption and connected by untyped links, the Semantic Web is one in which data is published in machine-readable form and the nature of connections between related items is made explicit. The transition from a Web of documents to a Web of data lowers the barriers to integration of data from distributed sources, and paves the way for a new generation of applications that can exploit this in order to enhance the user experience. This talk will demonstrate how the Web of data has moved from vision into reality, question how applications built on this distributed data set may change our mode of interaction with the Web, and examine how the Web of data might allow existing social processes to mitigate spam and information overload.

### **About Tom Heath**

Tom Heath is a researcher in the Platform Division at Talis, a UK software company specialising in Semantic Web technologies and applications, where he is responsible for research into recommender systems and collective intelligence. Tom's work at Talis builds on his previous doctoral research into trust, recommendation and social networks in the Semantic Web, conducted at The Open University's Knowledge Media Institute. As part of that work he developed Revyu.com, a reviewing and rating site for the Web of data and winner of the 2007 Semantic Web Challenge. Tom has over 10 years development experience with Web technologies, and a first degree in Psychology.

## **Commercialization of Semantic Technologies in Malaysia**

### **Keynote Speaker**

**Dickson Lukose**

(MIMOS, Malaysia)

dickson.lukose@mimos.my)

In recent years, Semantic Technologies have been in the forefront of attention of the major governments, industry, academic and investors around the world. Much research was conducted by Artificial Intelligence researches in the 1980's in the area of Knowledge Representation and Reasoning, specifically in the area of Semantic Networks. But, only recently, we achieved standardization via the W3C initiatives, which gave the impetus for industry players and investors to look seriously into Semantic Technologies. Though the major drivers of innovation in Semantic Technologies are Semantic Web, one could see that Semantic Technologies are a somewhat broader concept than the Semantic Web. Although the Semantic Web is obviously based on Semantic Technologies, the latter include non-Web applications. The main goal of Semantic Technologies is to capture (semi-)structured and unstructured knowledge in a format that can be used by computers and humans alike. When one looks into the overall eco-system that drives semantic technologies, one could conclude that Europe is pretty much the leaser in research, while north-America is leading in the development of semantic technology tools. Even though there are numerous application developments taking place in Europe and north-America, the industry analyst predictions are that largest growth and investments will be taking place in the Asia region. Realization of this is no well reflected in the national R & D agenda of many nations in the region. Malaysia is one of the countries in the Asian region that are totally committed in preparing itself to capitalize on frontier technologies. Semantic Technology being one of the major focuses. Conducting applied R & D on Semantic Technologies and moving these technologies to local industries to take it up is a monumental challenge. Some of the major obstacles faced (certainly not an exhaustive list) include the lack of expert researches in Semantic Technology in the country, non-competitive compensation packages makes it difficult to attract best people from around the world to Malaysia, lack of research culture among the local industry players, preference of local industry to purchase western technologies rather the home grown technologies, and the lack of skilled personal within our local industry players to take on sophisticated technologies like the Semantic Technology. In this keynote address, the speaker will outline the methodology adopted by MIMOS BHD on how we overcome the above mentioned challenges, to carry our the necessary R & D in Semantic Technologies, preparing local industries to become our technology recipient, and how we help local companies to commercialize Semantic Technologies.

**About Dickson Lukose**

Dr. Dickson Lukose (PhD) is the Head of the Knowledge Technology Cluster at MIMOS BHD. Dr Lukose is also the director of the Artificial Intelligence Laboratory as well as the Centre of Excellence in Semantic Technologies. Prior to MIMOS BHD, Dr Lukose was involved with a startup company named DL Informatique Sdn. Bhd., an MSC Status Company specializing in the applications of Artificial Intelligence Technology in developing software applications in the areas of Risk Management and Knowledge Management.

# **Emergent Innovation—a Socio-Epistemological Innovation Technology**

## **Creating Profound Change and Radically New Knowledge as Core Challenges in Knowledge Management**

**Markus F. Peschl**

(University of Vienna, Vienna, Austria  
Franz-Markus.Peschl@univie.ac.at)

**Thomas Fundneider**

(tfc consulting, Vienna, Austria  
tf@tfc.at)

**Abstract:** This paper introduces an alternative approach to innovation: Emergent Innovation. As opposed to radical innovation Emergent Innovation finds a balance and integrates the demand both for radically new knowledge and at the same time for an organic development from within the organization. From a knowledge management perspective one can boil down this problem to the question of *how to cope with the new and with profound change in knowledge*. This question will be dealt with in the first part of the paper. As an implication the alternative approach of *Emergent Innovation* will be presented in the second part: this approach looks at innovation as a socio-epistemological process of “learning from the future”.

**Keywords:** innovation, radical innovation, emergent innovation, knowledge creation, change

**Categories:** L.2.3, M.4

## **1 Introduction—Innovation and Knowledge**

What makes successful radical innovations so fascinating? What does creating “radically new knowledge” mean in the context of knowledge management? Why are so many innovation projects doomed to failure, although a lot of resources are allotted to these projects? How can a *culture of radical innovation* be introduced into an organization, in its processes, products, services, and business models which—despite its radical nature—fit into the existing structures of the organization?

Innovation is among the most challenging processes in the context of knowledge management. Nevertheless the creation of (radically) new knowledge is the key for almost every domain in a business or organization—even more so, if the main product or service is focused on knowledge. What makes innovation processes so difficult and challenging? Primarily, because they have something to do with the future and how to “behave” in the future; more specifically, with constructing knowledge which has to fit both into external future changes (including the resulting new requirements) and to what and where the organization will be at this point in time (e.g., concerning its technology, knowledge, human resources, etc.). In most cases these future states are almost impossible to predict accurately, because the underlying social, economic,

technological as well as knowledge dynamics is too complex. In a way we are in a similar situation as science and technology always is: one is trying to predict an aspect of reality in order to increase the level of control over this aspect—the only way one can achieve this is to create new knowledge and apply it in various contexts.

Hence, *innovation* and *knowledge* are intrinsically coupled in a complex knowledge process: (i) acquiring knowledge (via observation, etc.), (ii) abstracting and constructing knowledge (understanding), (iii) creating new knowledge, and (iv) realizing this knowledge in concrete prototypes; (v) after fast cycle learning processes on these prototypes (vi) this newly generated knowledge gets embodied in the organization.

Taking this radically knowledge oriented perspective on innovation seriously, one can boil it down to the question of *how to cope with the new and with change*. This question will be dealt with in the first part of the paper. As an implication an alternative approach to innovation will be presented in the second part: *emergent innovation*. This approach looks at innovation as a socio-epistemological process of “learning from the future”.

## 2 Ways to Cope With the Challenge of Change and with the Demand for the New

Coping with change is at the heart of any innovation process. In most cases the challenge is how react to this change with a strategy which is based on new knowledge or—even better—to *anticipate* this change and proactively shape the future with new knowledge. From a knowledge perspective this is a triple challenge: one has not only to react to a change which has occurred already; rather, (a) one has to *anticipate* this change and (b) to *relate* it to a possible future state of one’s own knowledge (be it in one’s own business, human resources, technology, etc.). (c) Above that, one has to *shape* a whole future scenario which integrates these domains in a (radical) innovation (radically new knowledge, business model, service, product, etc.). Of course, this is the most sophisticated form of dealing with the challenge of change. In the following paragraphs we are going to discuss different *levels and strategies* of how to deal with change (see also [Scharmer, 07; Senge, 90]):

1. *Reacting and downloading* is the simplest way of responding to change. Already existing and well established behavioral, organizational, perceptual, or cognitive patterns are applied to solve the problem or the learning/adaptation task. This is the most convenient and most economic way of reacting to change, because it requires only downloading of already prefabricated solutions, knowledge, patterns, etc. The price of this simple response is quite high: (i) the reactions are highly rigid and (ii) the resulting solutions or changes do not go very deep and in most cases do not even scratch the underlying issues of the problem. However, this mode of dealing with change is what most cognitive systems and organizations do most of their time.
2. *Restructuring and adaptation* goes one step further by not only applying already existing knowledge patterns, but to use these patterns as a blueprint which is *adapted* slightly to the current situation. From a cognitive

perspective this is a highly efficient learning strategy, because it is not as rigid as downloading, but it can be done with minimal cognitive effort; namely, to make use of already existing knowledge, patterns, change them slightly and apply them to the new situation, task, etc. From the field of cognitive (neuro-)science these processes are well understood—these are the classical learning and adaptation processes well known from the domains of connectionism or computational neuroscience (e.g., [Bechtel, 02; Peschl, 01; Rumelhart, 86] and many others). From this perspective it becomes clear that these processes are mathematically equivalent with processes of *optimization*. I.e., we are searching for an optimum in an already pre-structured space (of solutions). These processes of optimization normally lead to *incremental innovations* [Ettlie, 84].

3. *Redesign and redirection*: The focus of this strategy to cope with change is to primarily explore one's own patterns of perception and thinking in order to be able to assume *new perspectives*. In that process the focus of attention shifts from the external object to the source of one's cognitive and perceptual activities—this shift is referred to as *redirection* [e.g., Depraz, 03, Varela, 00]. This can be done individually, however, it is much more effectively in a collective setting. The goal is to arrive at a position from which it is possible to take different standpoints and to understand what one's own patterns of perception and thinking are—these insights act as a starting point for creating new knowledge and for the following level of reframing.
4. *Reframing*: The process of redirection does not touch the domain of assumptions in most cases; downloading, adaptation, and optimization are sufficient for mastering everyday problems and challenges. In a way these solutions are not very interesting from the perspective of radical change, because they do not bring forth fundamentally new knowledge, insights, or understanding. Fundamental change is always connected with reflection of *deep assumptions* and stepping out of the—more or less consciously—chosen framework of reference. I.e., going beyond the boundaries of the pre-structured space of knowledge and “reframe” it in the sense of constructing and establishing new dimensions and new semantic categories. This process concerns the level of mental models, premises, deep assumptions and their change. In dialogue-like settings (e.g., [Bohm, 96]) these assumptions are explored in a double-loop learning manner [Argyris, 96]. Going one step further, this process of reflection leads to the construction of completely new conceptual frameworks enabling the reframing of already well established cognitive structures. These are the basis for *radical innovations*.
5. *Re-generating, profound existential change, and “presencing”*: On a more fundamental level, change goes beyond reframing; it is not only concerned with intellectual or cognitive matters and modifying assumptions any more. In that more fundamental context, questions of *finality, purpose, heart, will*, etc. come to the fore—what they have in common is that they concern an *existential* level rather than a cognitive level. From a learning perspective these processes are realized in the triple-loop learning strategy [Peschl, 07]. In this mode change is not solely based on cognitive reflection any more, but more importantly on *existential reflection* and learning. In a way the goal is



to bring the existential level of the person and the organisation (i.e., its acting as well as its core) into a status of inner unity /alignment with itself and with its future potentials as well as with future requirements. What might sound esoteric is in fact a very old theme and philosophical issue going back at least to Aristotle's philosophy. Very often these questions concern the domain of the core/substance of the innovation object and of *wisdom*. Due to its existential character [Scharmer 00, 07] and [Senge, 04] refer to this mode of change/learning as "*presencing*". It represents an approach to innovation which does not primarily learn from the past, but which shifts its focus towards "*learning from the future as it emerges*". I.e., the goal is to be very close to the innovation object and at—the same time—completely open to "what wants to emerge" (out of the surrounding, out of the organization, its humans and its knowledge)—the difficult part in this approach is (i) to profoundly understand the situation (i.e., the core of the innovation object) plus its context, (ii) to match these insights with the potentials which want to emerge, and (iii) to bring them into a consistent and integrated picture. In short the process of presencing is about a fundamental examination of the *core* of the innovation object leading to a profound, holistic, and integrated understanding of this object including its context— only a highly nurturing environment for generating profound new knowledge may give rise to *radical innovations* which are not only radically and fundamentally new and completely "out of the blue", but which are also *fitting well* into what emerges in society, in the organization, and in culture in general.

These strategies of coping with change and innovation do not exclude each other; in most cases aspects of almost every level are present in one or the other way in innovation processes—the interesting question for an organization is where it shifts its focus to. For instance, [Nonaka's et al., 03] (revisited) SECI model focuses on the interplay between implicit and explicit knowledge and how this interplay can act as a source for the generation of new knowledge. It is clear that levels 3–5 are *intellectually challenging* and demands for an explicit culture of openness, innovation, and real commitment to (radical) innovation both on an individual and a collective level. From an innovation perspective, these levels are most interesting—hence, the question: how can these innovation processes of levels 4 and 5 be realized in organizational settings?

### 3 Emergent Innovation

Besides their manifestations as entirely new, surprising, and convincingly coherent services, products, or business models the fascinating aspect of "real" fundamental innovations are the "mental innovations" and the "mental change processes" of knowledge (creation) having led to these manifestations. How can they be brought about?

#### 3.1 Incremental and Radical Innovation

[Ettlie, 84] (and many others) differentiate between processes of *incremental* and *radical* innovation. Incremental innovation is characterized by minor changes and

optimizations which do not touch the underlying concepts; “...incremental innovation refines and extends an established design. Improvement occurs in individual components, but the underlying core design concepts, and the links between them, remain the same.” ([Henderson, 1990], p 11).

While incremental innovation goes for optimization (see also level 2 section 2) the focus of radical innovation is on changes in the more profound domain of core concepts or base principles. In most cases, making changes in these fundamental domains implies radical changes in the whole product or service (plus its context; e.g., by opening up completely new markets). In other words, radical innovation starts off with changes the assumptions (see also level 3 and 4 above). „A change in principle, then, fits with our intuition of what constitutes a novel technology. I will therefore define a new (radically novel) technology as one that achieves a purpose by using a new or different base principle than used before.“ ([Arthur, 07], p 278)

### 3.2 Emergent Innovation: Radical Yet Organic Innovation from Within

We are proposing an alternative approach and knowledge technology to those two classical paradigms of innovation: *emergent innovation*. This concept of innovation follows a fundamentally different approach: it is a *socio-epistemological technology* focusing on the cognitive and social processes leading to a new type of innovation (process).

#### *Emergent Innovation and Profoundly Understanding the Core*

This kind of *innovation emerges* out of a process of (i) a profound understanding of the innovation-object and (ii) reflecting and letting-go of predefined patterns of perception and thinking (compare also U-Theory [Scharmer, 07]). This leads to *radical, yet “organic innovations” in the sense of both respecting and developing/changing the core/essence of the innovation-object* (be it a business, service, product, idea, etc.). This socio-epistemological technology of emergent innovation is a highly fragile and intellectually challenging process which has to be held in a container which we are referring to as *enabling space* [Peschl, 07a]; it is a multi-dimensional space enabling and facilitating these processes of knowledge creation. This enabling space comprises of a physical, social (trust, etc.), mental/cognitive, epistemological, as well as technological dimension.

#### *Emergent Innovation as a Collective Socio-Epistemological Process*

In most cases, innovations do not just happen by chance. A culture of openness, learning, creativity, readiness for error, etc. must be fostered and rewarded in order to make innovation happen in an organization. On an individual level, this is typically depended on the personal ability, traits, and commitment of a single person or a rather small group of interested individuals; on an organizational level, establishing this culture primarily is a leadership task (setting goals, setting examples, rewarding, enabling structures for free spaces, etc). Regardless of the many techniques available to stimulate innovations, most innovation processes are based on the classical process steps of: idea generation, idea selection, idea management and realization of plans. In many cases the techniques being used in this process are massive brainstorming sessions (quantity first), market research, user testing, external studies etc. Most

outcomes of such an approach are *incremental* innovations, as the basic thinking behind these processes does not go beyond level 2 (see section 2).

Besides the fact that *radical* innovations are non-predictable and rare, they are based on mental “outbreaks” (level 4, 5; section 2); in most cases radical innovations are tied to *single persons*, so-called “mavericks”—individuals who think outside the box. In case such a maverick (being very good in generating radically new ideas) teams up with a partner who has the personal traits of realizing things, radical innovations may lead to successful products or services; history shows, however, that most (radical) innovation initiatives fail on an organizational level. The reasons for this lie in the fact that these processes are highly dependent on a rather small group of individuals and on their involvement; hence, these innovation processes are standing on a rather shaky and fluctuating ground. Furthermore, they are implicitly based on the assumption that radical innovation is based on “far out”, “creative”, and completely orthogonal ideas (grafted onto the business from the outside), on a high quantity of—in most cases low quality—ideas going through a rigorous selection/evaluation process, etc. which makes the whole process even more erratic and unpredictable.

The core idea is that *emergent innovation* is not primarily dependent on exceptional individuals who are supposed create radical innovations, but that selected members of an organisation acquire the understanding and skills in the basic thinking that underpins the processes of levels 4 and 5 in section 2. In some cases radical innovation and emergent innovation may lead to similar outcomes (product, service, process, strategy); the processes having lead to these results are completely different, however: on the one hand, a few outstanding individuals generate radically new knowledge on an occasional basis, on the other hand a team of well-selected and trained members of the organisation are responsible for a continuous flow of radical innovations.

#### *Why “Emergent” Innovation?*

What is emergence in the context of innovation? In general, emergence means that some system display qualities which cannot found in its components [e.g., Stephan, 99]—i.e., features emerge out of the interaction of the system’s components (on the micro-level) as “new qualities” on the macro/collective level.

The approach of Emergent Innovation takes this phenomenon seriously in a several dimensions: (i) (radically) new knowledge is not primarily the result of analytic processes, but is understood as an emergent phenomenon. (ii) It develops/emerges “from within”: i.e., much of what emerges is implicitly already present—the challenge is to explore the space of potentialities and enable the process of emergence; (iii) this is achieved by applying another notion from the theory of emergence: the importance of constraints—if they are well orchestrated this might lead to an emerging phenomenon (however, it does not determine it; compare also the concept of enabling spaces [Peschl, 07a]). (iv) Finally, emergent innovation is a highly social process in which the collective dimension plays a crucial role: new knowledge emerges out of the interaction between a group of individuals in a structured socio-epistemological process of interactions and constraints.

Comparing the concept of emergent innovation with, for instance, the standard model of knowledge creation/management, such as [Nonaka’s et al., 03] SECI model,

there are, of course, compatibilities; however, one can clearly see that the process of emergent innovation goes far beyond creating new knowledge out of the tension between tacit and explicit knowledge—rather:

- The cognitive capacities of observation, thinking, reflection, etc, are developed in a systematic manner; the space of potentialities is explored in a thorough way;
- The creation of new knowledge goes beyond combination of existing knowledge by radically letting go of existing pieces of downloaded knowledge and patterns of thought and yet organically fitting it into existing structures;
- The process of creating knowledge is future oriented: i.e., what wants to emerge is more important than the (re-)combination of already existing knowledge structures, etc.

#### 4 Conclusion and Future Work

The following points have turned out to be crucial in the emergent innovation approach:

- Focus on processes of cognition and perception as well as changing them profoundly (via techniques of radical reflection, questioning, dialogue, deep observation, etc.).
- Primacy of profound and holistic understanding of the innovation subject/object as opposed to the production of a high quantity of ideas with relatively low quality.
- Focus on the process of *emergence* of innovation and on enabling this process (instead of imposing or forcing it; see “enabling space”).
- Seeing, profoundly understanding, and respecting what is (already) there — understand what is already there as a chance rather than an obstacle.
- “*Organic radical innovation*”: Respecting and at the same time exploring and developing the most radical and unforeseen potentialities of the (profound understanding of the) core/essence of what is already there. In this sense emergent innovation is a kind of “radical innovation from within”.
- *Thinking innovation from the future potentialities* instead of repeating and extrapolating patterns from the past. The question “what wants to emerge” is a pointer into the future and implicitly instructs the whole process of emergent innovation/knowledge creation.

Several innovation projects have proven that this socio-epistemological technology can be applied in a wide field of industries, sciences, etc. Still, there are many points to be developed and refined in this project.

#### Acknowledgements

This project is funded by the ZIT (Center for Innovation and Technology, Vienna, Austria).

## References

- [Argyris, 96] Argyris, C. and D.A. Schön: *Organizational learning II. Theory, method, and practice*. Redwood City, CA: Addison-Wesley, 1996.
- [Arthur, 07] Arthur, W.B. The structure of invention. *Research Policy* 36, 274–287, 2007.
- [Bechtel, 02] Bechtel, W. and A. Abrahamsen: *Connectionism and the mind. Parallel processing, dynamics, and evolution in networks* (second ed.). Malden, MA; Oxford, UK: Blackwell Publishers, 2002.
- [Bohm, 96] Bohm, D.: *On dialogue*. London; New York: Routledge, 1996.
- [Depraz, 03] Depraz, N., F.J. Varela, and P. Vermersch: *On becoming aware. A pragmatics of experiencing*. Amsterdam / Philadelphia: John Benjamins Publishing Company, 2003
- [Ettlie, 84] Ettlie, J.E., W.P. Bridges, and R.D. O’Keefe: Organizational strategic and structural differences for radical vs. incremental innovation. *Management Science* 30, 1984.
- [Henderson, 1990] Henderson, R.M. and K.B. Clark. Architectural Innovation: the reconfiguration of existing product technologies and the failure of established firms. *Administrative Science Quarterly* 35(1), 9–30, 1990.
- [Nonaka, 03] Nonaka, I. and R. Toyama. The knowledge-creating theory revisited: knowledge creation as a synthesizing process. *Knowledge Management Research and Practice* 1, 2–10, 2003.
- [Peschl, 01] Peschl, M.F.: Constructivism, cognition, and science. An Investigation of its links and possible shortcomings. *Foundations of Science* 6(1), 125–161, 1999.
- [Peschl, 07] Peschl, M.F. Triple-loop learning as foundation for profound change, individual cultivation, and radical innovation. *Construction processes beyond scientific and rational knowledge. Constructivist Foundations* 2(2-3), 136–145, 2007.
- [Peschl, 07a] Peschl, M.F. Enabling Spaces—epistemologische Grundlagen der Ermöglichung von Innovation und knowledge creation. In N. Gronau (Ed.), *Professionelles Wissensmanagement. Erfahrungen und Visionen*, pp. 362–372. Berlin: GITO, 2007.
- [Rumelhart, 86] Rumelhart, D.E. and J.L. McClelland (Eds.) (1986). *Parallel Distributed Processing: explorations in the microstructure of cognition*. Foundations. Cambridge, MA: MIT Press, 1986.
- [Scharmer, 07] Scharmer, C.O.: *Theory U. Leading from the future as it emerges. The social technology of presencing*. Cambridge, MA: Society for Organizational Learning, 2007.
- [Senge, 90] Senge, P.M.: *The fifth discipline. The art and practice of the learning organization*. New York: Doubleday, 1990.
- [Stephan, 99] Stephan, A. Varieties of emergentism. *Evolution and Cognition* 5(1), 49–59, 1999.
- [Varela, 00] Varela, F. : Three gestures of becoming aware. (Interview with F.Varela; Paris, Jan 12, 2000). <http://www.dialogonleadership.org/Varela-2000.pdf> [27.04.2005], 2000.

## **Challenge Knowledge Valuation**

**Hagen Schorcht**

(Technische Universität Ilmenau, Germany  
hagen.schorcht@tu-ilmenau.de)

**Volker Nissen**

(Technische Universität Ilmenau, Germany  
volker.nissen@tu-ilmenau.de)

**Abstract:** Despite intensive research within the field of knowledge management and its components, the issue of knowledge valuation and its organisational integration presents a big challenge. Existing research papers about knowledge valuation have remained on very abstract levels and therefore cannot be very easily adapted to the needs of a specific company. Often only scarce information is provided for specific practical implementation. This interferes considerably with the application of existing methods of knowledge valuation. In addition, support by information technology seems only seldom to be found nowadays, which also complicates the application of existing methods in organisations. The aim of this research paper is to compare selected established approaches of knowledge valuation on the basis of certain criteria. Furthermore, an analysis and identification of possibilities for improvement are given.

**Keywords:** knowledge valuation, knowledge management, strategic knowledge planning

**Categories:** A.1, M.3, M.9

### **1 Introduction**

Material and financial resources form the basic factors for business success. However, over the past few years knowledge within a company has emerged as a further value-bringing factor. The influence of knowledge has intensified through the change of our society from production-oriented to service-oriented. The importance of knowledge is especially intensified by its being viewed as a competitive factor [North, 05] and as fundamental factor for a strategically valuable competitive positioning.

[Probst, 06] postulate that there are two phases of knowledge valuation. Knowledge measurement as the first phase brings changes in the basis of knowledge into view. Phase two allows the interpretation of these changes with the help of knowledge goals. It is necessary to emphasise at this time that knowledge valuation does not refer to a monetary valuation of knowledge but rather the validation of the achievement of the knowledge goals aimed for [Probst, 06]. Knowledge goals can be understood as a fundamental element of knowledge-oriented commercial leadership [North, 05]. However, non-monetary methods for knowledge valuation represent only a minority amongst current scientific approaches. [Wohlfarth, 05] even claim that non-monetary valuation methods of immaterial resources are nonexistent.

Various procedures for classifying knowledge valuation approaches can be identified from the literature [Fink, 04], [North, 05]. The most extensive comparison is due to Alwert's classification [Alwert, 05]. Existing classifications observe the approaches from a very abstract perspective, which provides an adequate initial overview.

However, the existing classifications neither offer a comparison of input data, nor look at integration into an organisation or considerations for strategic management.

Due to the partly insufficient or missing consideration of required elements in existing approaches to compare knowledge valuation methods, a new comparison scheme will be introduced in the next section. Thereafter, this new scheme is applied to two established methods of knowledge valuation, highlighting some of the shortcomings of these approaches. The paper concludes by comparing the results for both valuation methods which provide a basis for some hints concerning the development of a new knowledge valuation approach.

## 2 Construction of an Evaluation

A large number of approaches for knowledge valuation can be found in the literature, such as [Stewart, 97], [Sveiby, 97], [List, 01] or [Bornemann, 07]. An overview of many established approaches is given in [Schorcht, 07]. Two main trends can be seen among them. The dominating category encompasses the so-called management approaches (abstract approaches). The basic objective of these methods is the alleviation of the problem of companies to demonstrate or account for their intellectual capital to shareholders. The goal therein is the extension of a companies balance sheet through the inclusion of the aspect of knowledge or rather a completely independent knowledge balance. The second category is more pragmatic; these approaches attempt to measure and value the knowledge of a company using sophisticated criteria. One goal of these approaches is the successful operational employment of staff members in a company.

What follows is an introduction to an evaluation scheme for methods of knowledge valuation developed on the basis of extensive own research work. The basis of this scheme is the consideration of the completeness of the valuation methods and the elements which are required to support meaningful benchmarking between different approaches. Four perspectives and 17 criteria are, thus, identified.

The *first dimension* “design and definitions” contains classification criteria and differentiators for the basic understanding of the valuation approach. The first criterion is ‘types of knowledge’ included in the knowledge valuation. Important aspects for contrast can be found in the knowledge types of affinity, transferability, importance and alignment. Another criterion refers to the ‘foundation of the evaluation’ that may be predominantly pragmatic or scientific. Moreover, knowledge valuation approaches can be analysed on the basis of their particular ‘understanding of knowledge’. For example, one aspect is whether knowledge is to be valued as a component of intellectual capital or as an independent object.

The *second dimension* “input and data basis” describes the approaches strategies for the selection and acquisition of data necessary for valuation, with a differentiation between the kind of input data and the process of data acquisition. For ‘input data’ both the quality and quantity of data are utilised for classification. In the field of knowledge management qualitative aspects, e.g. knowledge of an employee about customer or a specific sector, are of particular importance. Additionally, extensibility and adaptability of the inputs play an essential role. The main question here is “Can I customise the relevant data input to the requirements of my company?”. The aspect of

‘data acquisition’ highlights whether the process to obtain the data necessary for valuation is clearly described in the knowledge valuation method analysed.

<b>Dimension</b>	<b>Criteria</b>
Design and definitions	Knowledge types included Foundation of evaluation Understanding/Definition of knowledge
Input and data basis	Input data Data acquisition
Evaluation model and procedure	Indicators Cause-and-effect relationships Knowledge life cycle Orientation Time reference Knowledge goals
Output and benefit	Appropriateness for strategic knowledge planning/controlling Kind of output Generality Audience Alignment Tool support

*Table 1: Benchmark Criteria for Comparison of Knowledge Valuation Approaches*

The basic approach of the evaluation scheme is the scope of the *third dimension* “evaluation model and procedure”. This dimension analyses the internal structure and the principle procedure of the presented approaches. ‘Indicators’ are one of the basic elements of a knowledge valuation approach. Of particular interest is whether such indicators can be tailored to a companies specific situation or, at least, selected from a given list. The presentation of ‘cause-and-effect relationships’ is an important criterion for the use of a valuation scheme at the strategic level. Through these relationships a connection can be established between goals and their performance drivers, thus underpinning the strategic relevance of indicators. The determination of the half-life period of knowledge using a ‘knowledge life cycle’ also plays an important role in the valuation of knowledge and its strategic relevance. The ‘time reference’ refers to the timeframe of the analysis model, with a distinction between discrete and continuous approaches for measurement and analysis. The orientation of a valuation method describes the primary focus of the approach, e.g. financial consideration of knowledge.. The presence of ‘knowledge goals’ is a prerequisite for the transition from pure knowledge measurement to knowledge valuation and hence plays an important role in our scheme.

The *fourth dimension* of classification criteria “output and benefit” is intended to analyse the result and usability of the approaches for companies. The criterion of ‘appropriateness for strategic knowledge planning/controlling’ helps to elicit to what extent the valuation scheme may be applied to support strategic knowledge planning and controlling. The ‘kind of output’ outlines what the result of the valuation methods looks like, meaning whether the result is a single value or a collection of values. ‘Generality’ of the approach measures how generic a valuation approach is for different companies and industries. The target group or ‘audience’ determines the intended addressee of the method, where people internal or external to a company are



a first rough differentiation. Also, for optimal applicability it is necessary for the approach to be integrated into further methods and procedures for planning and controlling already present in the company, which is indicated by the criterion of 'alignment'. The final criterion involves the analysis of the extent to which the approach is supported by an information processing system. All of the aforementioned criteria are listed alongside the appropriate dimension in table 1.

In the following section two selected approaches for knowledge valuation are presented and the above analytical scheme is then applied to them to evaluate their individual strengths and weaknesses.

### **3 Application of the Evaluation Scheme**

The two knowledge valuation approaches examined in this chapter mirror the fundamental characteristics of the two presented categories of knowledge valuation methods described in chapter 2, abstract vs. pragmatic. Both approaches are well known and commonly applied as methods of knowledge valuation. Scandia Navigator, a predominantly abstract approach, aims for using the results from knowledge valuation within the scope of business controlling. The more pragmatic KAM (Knowledge Asset Management) approach focuses on the measurement and valuation of knowledge from single staff members and the support by information processing systems for documentation and data acquisition.

#### **3.1 Scandia Navigator**

Scandia Navigator [Edvinsson, 97] integrates ideas from the Intellectual Capital Navigator by [Stewart, 97] and Balanced Scorecard (BSC) by [Kaplan, 96]. The primary task of Scandia Navigator is the valuation and management of knowledge capital. As a result, it is a controlling tool for organisations with a total of 111 performance indicators structured along the dimension of finance, customers, development /innovation and staff members. Three fundamental assumptions work as a basic frame for the approach:

Intellectual capital (IC) represents information complementing financial information but not subordinate to it. IC is non-financial capital and represents a gap between market value and asset value and IC represents indebtedness as activated capital.

For knowledge valuation, it is reasonable to concentrate on the human factor part within Scandia Navigator. The human focus has a profound influence on all other measurement areas within this approach and, thus, constitutes the central task. Scandia Navigator tries to capture the implicit knowledge of the staff members using 22 key figures. Table 2 summarizes our analysis of the Scandia Navigator approach of knowledge valuation. In the following, some points of the analytical scheme are highlighted.

Dimension 'Design and Definitions': The approach lacks integration of explicit knowledge. At the bigger part, the Scandia Navigator focuses on operative knowledge. There is only rare consideration of strategic knowledge. Considering its foundation, the Navigator combines elements of an abstract and pragmatic approach. It is based on scientific results w.r.t. some of the indicators used while it also uses

pragmatic elements like the IC-Report. The primary task is measuring intellectual capital. Knowledge as a part of IC takes only a subordinate place.

Dimension ‘Input data and data basis’: There is no indication as to the data acquisition process. Input data is quantitative or must be quantified. No suggestion is presented about the form of knowledge which can be used in the approach.

Dimension ‘Evaluation model and procedure’: In the key-figure system knowledge-based coefficients become linked with coefficients whose significance for knowledge is very low or non-existent. For example the Scandia Navigator combines indicators like “Percentage of employees under the age of 40” or “training costs per employee”. Furthermore, because of the quantification problem, some relevant but rather qualitative aspects are not integrated into the key figure system, such as the realised usage of knowledge. Also, key figures are selected from various aggregation levels and contents of meaning. That complicates their consolidation and collective consideration. The number of key-figures used in Scandia Navigator appears too high to be used in practical management. The focus is basically financial. As result, the generated IC-Report can be used as an extension of a company’s balance sheet. In the Scandia Navigator, there are no explicit knowledge goals and only few associations to the strategic relevance and use of knowledge.

Dimension ‘Output and benefit’: Due to the missing knowledge goals, there is a limited usability for knowledge controlling and knowledge-based corporate management. This problem is aggregated through the weak link between the approach and corporate management. Some design cognitions of the Scandia Navigator can help to better understand and structure processes of knowledge management. Concerning the methods output, the use of the IC equation (monetary calculation of IC) leaves a lot of room for interpretation and manipulation. This problem is even pointed out in the description accompanying the approach, though this does not reduce the potentially negative effects, especially for stakeholders. The main audience for the Scandia Navigator is clearly external parties. The goal of the approach is to show the intellectual capital as monetary value or extended balance sheet.

Overall, Scandia Navigator is a good approach in general, but with much potential for improvement. The strong financial focus seems especially obstructive for measuring and valuating knowledge. By combining the approach with ideas from the Balanced Scorecard, such as cause-and-effect relationships, a straight-forward enhancement of Scandia Navigator seems possible.

### 3.2 KAM (Knowledge Asset Management)

KAM method represents an analysis tool for the valuation of knowledge in companies which are familiar with the use of external consultants to support company tasks. A supporting software solution was also developed [Rathert, 03]. Both quantitative and qualitative values are used in the valuation process. The KAM method consists of four main elements.

*Relative knowledge balancing* is understood as a group of metrics for the increase and decrease of the existing knowledge within an organisation. *Absolute knowledge balancing* refers to measures of the monetary equivalents of knowledge within an organisation. These metrics serve the purpose of internal balancing. *Knowledge liquidity* offers a measurement of the availability and disposition of knowledge. The term also covers measurements of the processes necessary to

maintain knowledge liquidity and mobility in companies. *Knowledge controlling* includes processes for maintaining constant consulting quality in organisations and for the value-added controlling of knowledge “expense” in companies.

The most important element of knowledge measurement and valuation within the KAM method are the so-called “Knowledge Items” (KI). An important result of this approach is the emergence of a collection of KI of the company depicting the knowledge of staff members. Each KI has an identifier and includes, for instance, functional information such as potentials, processes and results (described by the functional component) as well as qualitative information such as stability (described by the qualitative component). We will now look at some characteristics of the KAM method using our scheme from chapter 2.

Dimension ‘Design and Definitions’: The KAM approach uses only implicit and operative knowledge. There is no discussion about explicit or strategic elements. This set limits to the strategic usability. KAM can be called a pragmatic approach that is based on the experience of consultants. Within the approach, knowledge is understood as the implicit knowledge of the employees. Other parts of intellectual capital are not examined.

Dimension ‘Input data and data basis’: The input data can be summarised as quantitative values. The consideration of qualitative elements turns out to be very low. Fungibility and availability represent the qualitative aspect of the KAM method. The data acquisition is described through a questionnaire and discussions with external consultants. Data acquisition through external consultants could cause problems. On the one hand subjectivity of external consultants cannot be eliminated, which results in a displacement of KI. On the other hand the effort required for the gathering and valuation of “Knowledge Items” can be difficult to justify.

Dimension ‘Evaluation model and procedure’: The ideas of cause-and-effect relationships as well as knowledge life cycle are alien to the KAM method. The orientation of the approach is predominantly financial. The main goal is the monetary valuation of “Knowledge Items”. Also, no knowledge goals are integrated in the approach. The KAM method can be described as a discrete approach. There is no suggestion to value knowledge in continuous time periods. The KAM method integrates 9 key-figures. They are not free selectable and not in conjunction with each other. The approach can thus be called more or less fixed.

Dimension ‘Output and benefit’: Due to the operative orientation, the approach has low strategic benefit. Some elements of the method, like availability, can be used as a basis for strategic considerations. The KAM method describes a non generic model where the focus is clearly on consulting-intensive companies. However, in principle the capability for use in other industrial sectors is given. Moreover, the idea of “Knowledge Items” may be used more generally for knowledge controlling purposes. The KAM approach uses a web-based tool for documentation and data acquisition through a questionnaire. However, a possibility of supporting the knowledge valuation is not part of the software.

The idea behind knowledge asset management – to measure knowledge in companies with the concept of “Knowledge Items” – possesses significant potential. The subjectivity of external consultants and the cost-benefit ratio for their employment in the knowledge acquisition part are distinct points of criticism.

Additionally, this fact is aggravated by the pace of fast changes in today's companies, because the system is only of minor significance without a continual adaption.

#### 4 Conclusion and future work

Our presented method of comparison differs from others, e.g. through the consideration of elements like knowledge types, the understanding of knowledge or the integration of knowledge goals. This naturally lead us to start preparing a new knowledge valuation approach, not discussed here in more detail.

Table 2 summarizes our analysis of the two approaches highlighted in the last chapter on the basis of the scheme from chapter 2. Several other valuation methods were also analysed in our study but must be omitted here for lack of space [Schorcht, 07].

<b>Criterion</b>	<b>Scandia Navigator</b>	<b>KAM</b>
Knowledge types	implicit, operative knowledge, sometimes strategic knowledge	implicit and operative knowledge
Foundation of evaluation	composition of abstract and pragmatic approach	pragmatic approach
Understanding/ Definition of knowledge	intellectual capital; especially human capital	knowledge of employees
Input data	only quantitative values or must be quantified	quantitative and qualitative values
Data acquisition	no description	questionnaire and discussions with consultants
Indicators	111 indicators; free selectable; only quantitative	9 indicators; not changeable; quantitative and qualitative
Cause-and-effect relationships	non existent	non existent
Knowledge life cycle	non existent	non existent
Orientation	basically financial focus; IC-Report	financial focus; monetary value of Knowledge Items
Time reference	discrete approach	discrete approach
Knowledge goals	non existent	non existent
Appropriateness for strategic knowledge planning/controlling	limited usability; especially no knowledge goals	limited usability; the use of "Knowledge Items" are practicable for knowledge controlling
Kind of output	intellectual capital (as monetary value)	sum of "Knowledge Items"
Generality	generic model with customizing investment	especially for consulting-intensive firms
Audience	corporate management, external parties	corporate management
Alignment	no suggestion	no suggestion
Tool support	non existent	web-based approach; only for documentation and information acquisition through questionnaire

Table 2: Results with Evaluation Scheme for Scandia Navigator and KAM

As is shown by example for both presented approaches, there exists a demand for research into holistic strategic orientation among knowledge valuation methods and their support through software components. The following conclusions can be drawn from the broader analysis:

It was determined that nearly all approaches focus on implicit knowledge. Explicit knowledge in the form of searchable, linked documents or knowledge maps is frequently not considered. Also negative is the missing integration of knowledge measurement and valuation approaches in existing knowledge management systems. Such integration would be advisable in order to create a holistic system and boost synergy effects. The application of mostly quantitative metrics is also questionable for the valuation of knowledge. The use of key figures proves to be in part quite doubtful and illogical. Knowledge can be regarded as a badly structured phenomenon, whose measurement and aggregation in a key figure system can be considered vague at best [Nissen, 03]. Therefore, it is especially important to account for this fuzziness in the construction of qualitative metrics and operators.

Further problem areas include the organizational integration and alignment of knowledge valuation approaches and their usage for strategic planning and controlling. The approaches analysed in our study do not offer the possibility to directly transfer knowledge valuation results to a system for strategic business management.

Often only scarce information is provided regarding the exact implementation aspects which considerably hinder the application of existing methods of knowledge valuation. Another problem area arises with the consideration of IT support. Unavailability of supporting IT-Tools complicates the application of these methods and approaches even more.

Summarizing, it has been shown in this paper that important elements of knowledge valuation are insufficiently or not at all covered by established knowledge valuation methods. Based on this understanding, a new approach for measuring and valuating knowledge is currently under development.

## References

- [Alwert, 05] Alwert, K.: Wissensbilanzen, In Mertins, K., Alwert, K., Heisig, P. (ed) Wissensbilanzen, Springer 2005, Berlin.
- [Bornemann, 07] Bornemann, M., Alwert, K.: The German Guideline for Intellectual Capital Statements - Method and Experiences, In Journal for intellectual Capital, Vol. 8 No. 4, 2007 563-576.
- [Edvinsson, 97] Edvinsson, L., Malone, M. S.: Intellectual capital: realizing your company's true value by finding its hidden brainpower, 1st edn. HarperBusiness, New York.
- [Fink, 04] Fink, K.: Knowledge potential measurement and uncertainty, Dt. Univ.-Verl. 2004, Wiesbaden.
- [Kaplan, 96] Kaplan, R. S., Norton, D. P.: The balanced scorecard: translating strategy into action, Harvard Business School Press 1996, Boston, Mass.
- [List, 01] List, B., Schiefer, J., Bruckner, R. M.: Measuring Knowledge with Workflow Management Systems, In DEXA'01 (ed) 12th International Workshop on Database and Expert Systems Applications, IEEE Computer Society Press 2001, Munich 467-471.

- [Nissen, 03] Nissen, V.: Unterstützung ausgewählter Aspekte des Wissensmanagements, In Biethahn, J., Kuhl, J., Lackner, A. (ed) *Soft-Computing in Wissenschaft und Wirtschaft 2003*, Göttingen 53-75.
- [North, 05] North, K.: *Wissensorientierte Unternehmensführung: Wertschöpfung durch Wissen*, 4th edn., Gabler 2005, Wiesbaden.
- [Probst, 06] Probst, G., Raub, S., Romhardt, K.: *Wissen managen: Wie Unternehmen ihre wertvollste Ressource optimal nutzen*, Gabler 2006, Wiesbaden.
- [Rathert, 03] Rathert, N. A., Krug, S.: *Knowledge Asset Management 2003*, [http://www.zentec.de/dokumente/kamcom/0302Rathert-Krug\\_kamcom\\_WI2003.pdf](http://www.zentec.de/dokumente/kamcom/0302Rathert-Krug_kamcom_WI2003.pdf), Accessed 03 April 2008.
- [Schorcht, 07] Schorcht, H., Nissen, V.: *Herausforderung Wissensbewertung 2007*, <http://www.db-thueringen.de/servlets/DerivateServlet/Derivate-13190?XSL.ContextID=>, Accessed 29 June 2008.
- [Stewart, 97] Stewart, T. A.: *Intellectual capital: The new wealth of organizations*, 1st edn. Doubleday / Currency 1997, New York.
- [Sveiby, 97] Sveiby, K. E.: *The new organizational wealth: managing & measuring knowledge-based assets*, Berrett-Koehler 1997, San Francisco, Calif.
- [Wohlfarth, 05] Wohlfarth, S., Fischer, D., Alwert, K.: *Bewertungsmethoden immaterieller Ressourcen im Fokus*, In *Wissensmanagement: das Magazin für Führungskräfte*, 44-46.

## Analyzing Organizational Information Gaps

**Hans-Jörg Happel**

(FZI Forschungszentrum Informatik, Karlsruhe, Germany)  
happel@fzi.de

**Ljiljana Stojanovic**

(FZI Forschungszentrum Informatik, Karlsruhe, Germany)  
stojanovic@fzi.de

**Abstract:** In this paper, we analyze the relation of private and public information spaces in organizations and its implication for organizational knowledge management. By private information spaces, we mean all (electronic) information, which is only accessible by a single person in an organization (e.g. local files or personal E-Mails). The organizational information space in turn, consists of all electronic information, which can be accessed by all or most members of an organization. Based on this distinction, we develop a notion of information gaps between the organizational and the individual worker's information space. We derive four basic situations and discuss the implications for organizational knowledge management in each one. We support our claims by describing results from initial evaluation studies.

**Key Words:** knowledge sharing, knowledge management, organizational memory, information retrieval

**Category:** H.2, H.3.7, H.5.4

### 1 Introduction

In complex project settings, successful collaboration requires an efficient transfer of knowledge among individual workers [Small and Sage, 2006; Hansen, 1999]. Therefore, the topic of knowledge sharing is widely investigated in the fields of organizational studies and information systems. It can be defined as a "dual problem of searching for (looking for and identifying) and transferring (moving and incorporating) knowledge across organization subunits" [Hansen, 1999].

Personalization and codification are typically described to be the two core strategies for knowledge sharing [Davenport and Prusak, 1998]. The personalization strategy primarily relies on personal communication to share tacit knowledge, which only exists in the "heads" of individuals (see e.g. [Davenport and Prusak, 1998]). In turn, the codification strategy targets explicit knowledge which is e.g. captured in documents.

A common IT-based enabler for knowledge sharing is the introduction of knowledge management systems (KMS, see e.g. [Alavi and Leidner, 2001; Maier, 2003]) such as central information repositories or groupware systems. However, the successful introduction and adoption of such systems is influenced by a number of motivational, organizational and technical barriers [Small and Sage, 2006;

Mooradian et al., 2006]. Previous research has shown, that workers in an organizational setting avoid to share information due to low personal benefit [Cabrera and Cabrera, 2002; Wasko and Faraj, 2005], privacy [Ardichvili et al., 2003; Desouza, 2003] and effort [Desouza, 2003]. Thus, the identification of methods and tools to foster knowledge sharing in organizations is considered a major problem in knowledge management research [King et al., 2002].

In this paper, we describe a framework which helps to analyze knowledge sharing needs and opportunities. In the following section, we will therefore introduce the notion of *information gaps* to describe the scattering of codified knowledge across private and public information spaces. Based on this, we discuss the implications for organizational knowledge management strategies. Afterwards, we describe how to *calculate information gaps*. We also report on results from initial evaluation studies, give a short overview on related work and discuss future work.

## 2 Information gaps

The overall information space of an organization contains all codified knowledge. It consists of the private information spaces of all employees and the public information space of the organization, which is accessible to all or at least most members of an organization. The scope of codified knowledge may include pieces of information such as reports, notes, electronic documents, E-Mails, bookmarks or data from arbitrary information systems.

For the remainder of this paper, we will restrict our analysis to *electronic documents*. Furthermore, we will regard the *terms* inside these documents as an abstraction for the knowledge they contain (e.g. about a specific project, person or technology). While this basically serves the simplification of our framework, we also consider it a viable assumption, since most electronic knowledge in organizations is nowadays accessed with *enterprise search* engines, which also abstract to term-based, plain keyword queries.

### 2.1 Defining information gaps

Due to the specialized expertise and interests of users, we expect a skewed distribution of knowledge across private and public information spaces. As a framework for further analysis, we derive a simple model of information distribution in order to illustrate this. In our model, we distinguish four general situations which are depicted in Figure 1:

**Information overload** – denotes the situation when there are enough documents concerning to a certain topic locally and in the public space. Thus, if a user seeks to satisfy an information need, she will be able to retrieve



more than enough results, but may have difficulties to select really valuable documents. From a knowledge management perspective, this could require measures to invest in advanced information access strategies, helping people to navigate the information space.

**Information shortage** – characterizes the opposite situation, when there exists few information, both locally and globally. Depending on the kind of information, this can be a signal to invest in knowledge creation / acquisition. Indeed, the issue of which knowledge to capture is considered a major knowledge management issue [King et al., 2002].

**Personal information gap** – can be identified, if there are lots of documents available publicly while the user has only few documents locally. Thus, the user has to rely on results from the public space in order to satisfy an information need. This could be the case for very generic, organizational topics, for which users do not store private documents but it could also signal an information need for the person under consideration if the topic is of relevance for her work.

**Organizational information gap** – finally describes the situation, when the user has lots of information on a topic, while there is few information publicly available. This means that other users searching for that information might not be able to satisfy their information need, although there is information in the private space of at least one user in the organization. If this information is considered relevant for the organization, there should be investment in knowledge sharing – e.g. to motivate people to share their knowledge. In [Happel et al., 2007] we describe how to use insights from this analysis to design a concrete tool-support for knowledge sharing.

However, this kind of gap analysis provides a snapshot of the as-is situation – i.e. the information that is already available – but does not talk about actual information *needs*. The information need of a single user is a primary subject of investigation in information retrieval (IR). It can be defined as information which a user requires to complete a specific task [Baeza-Yates and Riberio-Neto, 1999]. The main purpose of IR systems is to help users satisfying their information needs by providing a set of relevant documents.

We argue that the scattering of information throughout the organization (*information gaps*) makes it hard for users to efficiently satisfy their *information needs*, since much relevant information is hidden in private information spaces, which are not accessible to them. Thus, from an organizational perspective, information gaps need to be bridged in order to achieve an efficient allocation of information. For assessing these gaps, access to real documents in both private and public information spaces is required. In the following section, we will

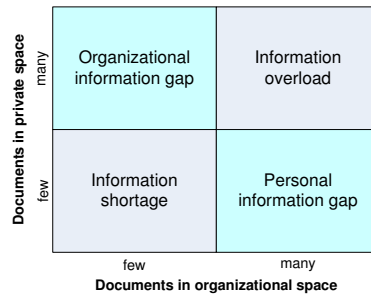

Figure 1: Availability of documents containing certain terms in the private vs. organizational information space

describe how to compute information gaps and describe results from initial evaluation studies using these measures.

### 3 Evaluation

In order to test our framework, we conducted an evaluation in our organization. The basic goal was to test our assumption of an unequal distribution of information, as described in the previous section. We therefore describe how to calculate information gaps, the setup of our evaluation study and conclude with discussing its results.

#### 3.1 Calculating information gaps

As already stated, our analysis of actual information gaps in this paper is based on the information retrieval notions of documents and terms. Therefore, computing information gaps basically involves a statistical comparison of the private information space of users and the public information space of the organization. Technically, this requires an index of the private documents of each user and a public index for the documents in the public space.

The computation of information gaps is quite straightforward. We employ basic statistical measures from information retrieval, which count the frequency of terms in documents (see e.g. [Baeza-Yates and Riberio-Neto, 1999]). Therefore, we need both the global and the local document frequency for each term, normalize it by the total number of documents in each corpus (information space), and rank the results by their difference.

The normalized document frequency (NDF) is computed as follows: Let  $N$  be the total number of documents in a corpus and  $t$  a term.  $N_t$  is then the subset

of  $N$  which contains  $t$ . The document frequency (DF) for a given term  $t$  can then be defined as the size of  $N_t$ . Accordingly, the normalized document frequency (NDF), which is normalized by the size of the corpus, is defined as:

$$NDF(t) = \frac{DF(t)}{N} \quad (1)$$

Since we are interested in the information gap between the private corpus of a particular user and the public corpus, this organizational information gap (OIG) for a certain term is defined as the difference of the local NDF and the public NDF. The difference of both values denotes the organizational information gap (OIG) for a certain term:

$$OIG(t, user) = NDF(t)_{user} - NDF(t)_{global} \quad (2)$$

Note that the value for  $NDF(t)_{user}$  can be computed in two different ways. It can either be computed for an individual user or as an average value for all users in an organization. While the latter value might be more valuable in terms of knowledge management considerations, it is more sensitive with respect to privacy issues. In general, it will not be possible to access private information spaces from a central authority for analysis purposes as described in this paper. However, an information gap analysis can also be beneficial from the local perspective of a single user.

In the following section, we will use these calculations to evaluate our notion of information gaps as introduced in section 2.

### 3.2 Evaluation setup

In order to calculate information gaps, we analyzed the private information space of 13 users from our organization as well as the public information space. Therefore we implemented a program that scans the harddisk for documents, extracts all terms from these documents and creates an index structure. The term extraction and index creation is carried out by using the Apache Lucene library<sup>1</sup> with its default settings. After creating indexes of all private information spaces and the public information space, our program calculated the information gap as described previously and created a list of terms and their information gap.

Regarding the type of documents, we decided to restrict our analysis to Word documents (\*.doc, \*.docx), because we assume that most of them were created within the organization. We expect that such documents are more often stored in the private space, in opposite to e.g. PDF-documents, which might have been downloaded from the web. Regarding the private information spaces, our 13 users were allowed to exclude folders containing sensitive or not work-related

<sup>1</sup> <http://lucene.apache.org>

information from the analysis. For the public index, we selected the root folder of our group’s fileserver, which can be accessed by all users and which contains a lot of shared information about projects, scientific topics, administrative procedures and related issues.

### 3.3 Evaluation results

The basic results are shown in Table 1. The fourth column (Unique terms vs. Public) shows the number of terms, which only appear in the respective user’s index, but not in the public index. The fifth column shows the number of terms, with an OIG value larger than 0. For the data underlying the table, we excluded terms with a document frequency of 1 and those with a higher document frequency in the public space ( $DF(t)_{user} < DF(t)_{public}$ ). A total number of 6147 terms have an organizational information gap of 0,5 or higher.

Index	Docs	Terms	Unique terms (vs. Public)	$val(t) > 0$
Public	5330	224009	-	-
UserA	12	3624	300	110
UserB	40	13220	1795	428
UserC	216	24059	8030	3578
UserD	65	11754	2289	637
UserE	710	61918	25367	7901
UserF	35	12719	1871	39
UserD	10	3867	946	930
UserE	1466	78251	44033	19723
UserF	2588	114950	66321	47426
UserG	196	19316	4450	1932
UserH	197	21589	3802	1616
UserI	315	21025	5215	2817
UserJ	5	5274	190	325

**Table 1:** Distribution of terms in the analyzed indices

We also sorted the terms of each user index by their organizational information gap. A qualitative examination of these lists shows surprisingly few ”noise”. Most terms intuitively stem from their owners background such as E-Mail addresses, zip codes and various terms related to ongoing projects and areas of expertise.

In a second step, we selected only those terms with a minimum document frequency of 5 in one of the 13 private corpora. This resulted in a list of 16714

terms. After removing duplicates from this list, 14674 terms remained. For each of these terms, we calculated the values  $NDF(t)_{public}$  and  $NDF(t)_{user-average}$ . The latter was the average  $NDF(t)$  value of the term across the 13 private corpora. The overall distribution is depicted in Figure 2.

As the plot shows, terms with a high OIG tend to be less frequent in the public corpus. On the other hand, terms which occur very frequently in the public corpus have no high OIG. 933 terms have an OIG value above 0,01 and 1398 below -0,01. Thus, 12343 terms are between these boundaries.

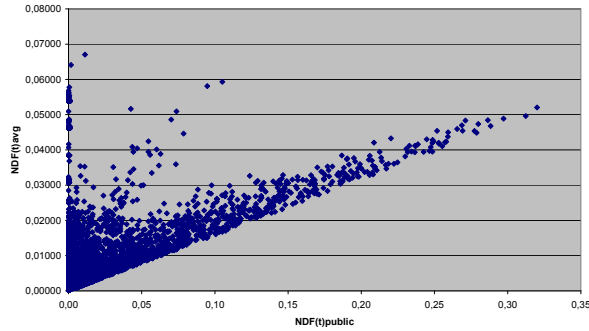

**Figure 2:** NDF values (public and average private for 14674 terms)

Note that these OIG-values are significantly lower than reported in Table 1, since they are averaged across all private corpora. However, there even seems to be a significant set of terms which has a different distribution across the overall (averaged) private corpus and the public corpus.

Although this is a rather preliminary evaluation, it clearly shows that there is a significant number of terms for which information is hidden in the private spaces of users. Relative term frequencies vary significantly among private and public information spaces in our data set, supporting our initial assumption of scattered information. This indicates that informations gaps exist and should be addressed by further research.

#### 4 Related work

Knowledge management- or organizational memory systems such as groupware systems, document repositories, enterprise search applications, expert databases and knowledge repositories have been developed to support various aspects of knowledge management resp. knowledge sharing (see e.g. [Maier, 2003; Kühn

and Abecker, 1997]). Most of these tools and approaches are organized centrally and either consider only public information or allow for defining access rights. There is typically no notion of private information spaces.

Private information spaces are addressed more seriously in the related areas of *distributed knowledge management* or *P2P information retrieval*. P2P-based IR systems such as Minerva<sup>2</sup> or P-Grid<sup>3</sup> assume that peers carry out crawling and indexing tasks and maintain a local index which is shared with other peers. Thus, they are also based on the assumption of shared information, even if it does not reside on central machines.

To summarize, existing approaches primarily distinguish private and public information spaces based on access rights. They do not analyze the relation of these spaces and thus do neither allow to draw conclusions of organizational knowledge management strategies, nor for the designing of more efficient knowledge sharing mechanisms.

## 5 Conclusion

In this paper, we introduced the notion of *information gaps* between private information spaces of users and the public information space of an organization. We derived four kinds of information gaps which imply different strategies for organizational knowledge management. We also described how to calculate those information gaps, and applied this in a small study of 13 subjects. Our results support the existence of information gaps and suggest further research on this issue.

We are especially interested in the situation of *organizational information gaps* – i.e. when the private information space of users contains valuable information, that is not available to other members of the organization. Further applications of our framework can be imagined related to expert finder systems, technology enhanced learning and organizational knowledge creation.

## Acknowledgement

This work has been supported in part by the TEAM project, which is funded by the EU-IST programme under grant FP6-35111 and the BMBF-funded project WAVES.

## References

[Alavi and Leidner, 2001] Alavi, Maryam ; Leidner, Dorothy E.: Review: Knowledge Management and Knowledge Management Systems: Conceptual Foundations and Research Issues. In: *MIS Quarterly* 25 (2001), No. 1, pp. 107–136

---

<sup>2</sup> <http://www.mpi-inf.mpg.de/departments/d5/software/minerva/>

<sup>3</sup> <http://www.p-grid.org/>

- [Ardichvili et al., 2003] Ardichvili, Alexander ; Page, Vaughn ; Wentling, Tim: Motivation and barriers to participation in virtual knowledge-sharing communities of practice. In: *Journal of Knowledge Management* 7 (2003), No. 1, pp. 64–77
- [Baeza-Yates and Riberio-Neto, 1999] Baeza-Yates, Ricardo ; Riberio-Neto, Berthier: *Modern Information Retrieval*. ACM Press, 1999
- [Cabrera and Cabrera, 2002] Cabrera, Angel ; Cabrera, Elizabeth F.: Knowledge-Sharing Dilemmas. In: *Organization Studies* 23 (2002), pp. 687–710
- [Davenport and Prusak, 1998] Davenport, Thomas H. ; Prusak, Laurence: *Working Knowledge*. Harvard Business School Press, 1998
- [Desouza, 2003] Desouza, Kevin C.: Barriers to effective use of knowledge management systems in software engineering. In: *Commun. ACM* 46 (2003), No. 1, pp. 99–101. – ISSN 0001-0782
- [Hansen, 1999] Hansen, Morten T.: The Search-Transfer Problem: The Role of Weak Ties in Sharing Knowledge across Organization Subunits. In: *Administrative Science Quarterly* 44 (1999), pp. 82–111
- [Happel et al., 2007] Happel, Hans-Jörg ; Stojanovic, Ljiljana ; Stojanovic, Nenad: Fostering knowledge sharing by inverse search. In: *K-CAP '07: Proceedings of the 4th international conference on Knowledge capture*. New York, NY, USA : ACM, 2007, pp. 181–182. – ISBN 978-1-59593-643-1
- [King et al., 2002] King, William R. ; Peter V. Marks, Jr. ; McCoy, Scott: The most important issues in knowledge management. In: *Commun. ACM* 45 (2002), No. 9, pp. 93–97. – ISSN 0001-0782
- [Kühn and Abecker, 1997] Kühn, Otto ; Abecker, Andreas: Corporate Memories for Knowledge Management in Industrial Practice: Prospects and Challenges. In: *Journal of Universal Computer Science* 3 (1997), No. 8, pp. 929–954
- [Maier, 2003] Maier, Ronald: *Knowledge Management Systems*. Springer, 2003
- [Mooradian et al., 2006] Mooradian, Todd ; Renzl, Birgit ; Matzler, Kurt: Who Trusts? Personality, Trust and Knowledge Sharing. In: *Management Learning* 37 (2006), No. 4, pp. 523–540
- [Small and Sage, 2006] Small, Cynthia T. ; Sage, Andrew P.: Knowledge management and knowledge sharing: A review. In: *Information, Knowledge, Systems Management* 5 (2006), No. 3, pp. 153–169
- [Wasko and Faraj, 2005] Wasko, Molly M. ; Faraj, Samer: Why Should I Share? Examining Social Capital and Knowledge Contribution in Electronic Networks of Practice. In: *MIS Quarterly* 29 (2005), No. 1, pp. 35–57

## **Towards Continuous Integration of Knowledge Management into Game Development**

**Steffen Lohmann and Jörg Niesenhaus**  
(University of Duisburg-Essen, Germany  
{steffen.lohmann, joerg.niesenhaus}@uni-due.de)

**Abstract:** Due to increasing professionalization and specialization in the development of computer and video games new challenges regarding the support of knowledge-intensive activities emerge. This paper aims at sensitizing and systematizing the needs and potentials for continuous integration of knowledge management into game development. It describes the interplay of development activities and involved parties with the knowledge creation process and provides insight into a tool-based approach that aims to support knowledge management in game development on three distinct levels.

**Key Words:** game development, knowledge management, continuous integration

**Category:** D.2.0, D.2.1, D.2.9, M.1, M.3

### **1 Introduction**

The game industry has gone through an overwhelming economic growth within the past years and analyst reports foresee a strong growth in the nearby future as well. The branch of game development and publishing is already a major industry with its strongest markets in North America, Japan, and Europe. Along with this ongoing growth comes an increasing professionalization in the development process of digital games. Higher budgets and larger development teams also cause a growing specialization. Due to the outsourcing of development parts, the whole process tends to be more geographically dispersed. In addition, specific components (e.g., game engines, graphic assets, level artifacts, or development environments) are frequently bought from third-party developers [Saltzman 2003].

Along with the professionalization and specialization of the game industry, the documentation and maintenance of knowledge in game projects gets a higher priority. Complex dependencies have to be handled and not only data but also knowledge has to be transferred between project partners. Furthermore, a huge amount of knowledge on content-specific aspects of games is generated, such as the design of the game world, the storytelling, the basic game mechanics, and technical specifications (vgl. [Rollings 2003]). In simple terms: An essential part of game development is knowledge management.

However, the integration of knowledge management support into the development of digital games is confronted with specific challenges: Game development is characterized by very agile and creative processes. These processes should not



be affected in their development by too systematic approaches or restricted methodical procedures. Thus, the key to success lies in an agile, minimal-invasive knowledge management approach having at best only little effect on the processes, not dictating strict procedures, coming along with minimal effort and simultaneously offering an immediate additional benefit to the project and all participants.

The rest of the paper is structured as follows: Based on a brief description of the state of the art in Section 2, a conceptual framework is presented and potentials for integrated knowledge management are identified in Section 3. Subsequently, a tool-based approach providing different levels of support is introduced in Section 4 and a short conclusion is drawn in Section 5.

## 2 State of the Art

So far, no established or even standardized continuous support for qualitative knowledge management exists in the area of digital games. Due to the many differences between game projects and work-related software projects, existing methods cannot be assigned to the area of game development without difficulty.

Normally, development studios use version control systems (such as *Perforce*<sup>1</sup>, *Alienbrain*<sup>2</sup>) in order to administrate data and documents. Knowledge about technical and game mechanical issues is primarily stored inside the single documents and files of the respective version control system that are updated in variable time intervals. Outdated knowledge partially exists for any length of time – contrary and inconsistent conclusions across several documents are not rare.

In General, it is differentiated between runtime files and design documents. The game is generated out of the runtime files (e.g., engine, scripts, graphics) in its different design stages due to ongoing testing. The design documents describe guidelines and design decisions concerning the use of technology and game mechanics and define responsibilities.

The absence of a global document and knowledge management is clearly noticeable in this structure. Though it is common practice to set references within the design documents to other documents, this happens predominantly manually so that references often become obsolete or fragmentary as time passes by. In many cases, most files are insufficiently or not at all commented due to lack of time. Thus, the function of a file can often only be derived through its location in the file system, the version control structure, and its name.

---

<sup>1</sup> *Perforce* is a software configuration management system. More information at <http://www.perforce.com>

<sup>2</sup> *Alienbrain* is an asset management system that mainly supports graphic intensive projects. More information at <http://www.softimage.com/products/alienbrain>

It is primarily not the competitive situation of single team members or organizational units and teams between each other but rather the additional effort that prevents team members from externalizing their knowledge. No appropriate possibility is offered for documenting knowledge adequately and making it retrievable in later stages of development.

### 3 Potentials for Integrated Knowledge Management

By analyzing typical activities along the game development process, several connecting factors for knowledge management support can be identified.

#### 3.1 Knowledge Management with Respect to the Development Process

At the beginning of the game development process in the phases of *pitching* and *pre-production* (see Figure 1) central activities are the generation of ideas and the creation of new game concepts: Numerous ideas are generated, developed, and discarded so that the shape of the game concept changes again and again. Converting these agile processes into permanent knowledge is of great value for a development team because it allows to reconstruct at a later time why ideas were discarded, why incompatibilities existed, and how a problem was finally solved. During the development of a game it occasionally happens that the team returns to an earlier point of discussion and reconsiders decisions on the basis of a new understanding of the game context.

In many cases, experiences of preceding projects are included in the considerations so that it is useful to activate knowledge of projects which have been accomplished in the past. Knowledge should always be connected with structures, files, and program code to enhance the chance of reusing already existing components [Rollings 2003].

With the beginning of the *production* phase, the demand of constant documentation increases with every generated version of the game. In this phase, priority should be given to the interconnection of file structures, data, and knowledge to make every step within the version control traceable and – if required – revocable at a later time.

After the completion of a game project the review and final feedback discussions start. This phase has come to be called *postmortem* in developer jargon. At this stage, the processes, problems, and experiences of the previous project are discussed in order to use this knowledge for future projects. In addition to the feedback given by the developers themselves, the experiences of the service units, the publisher as well as feedback of external experts, media representatives, and the community are brought into the discussion.

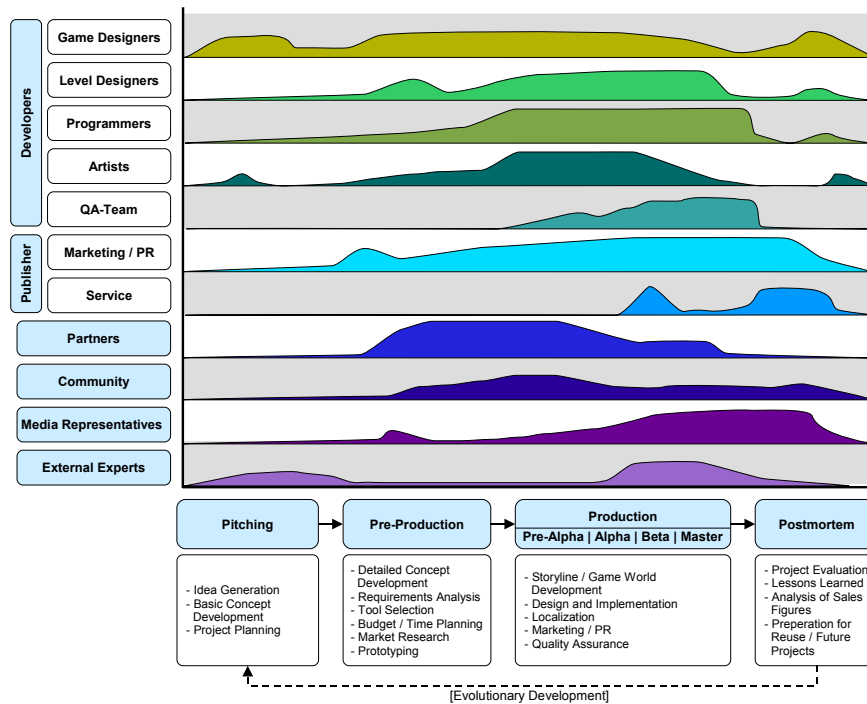

Figure 1: Typical game development process – The curves describe the distribution of intensity of the knowledge management activities.

### 3.2 Knowledge Management with Respect to the Involved Parties

The identification of participants involved in the development process clarifies the potentials of supporting knowledge management (see Figure 1).

The group of *developers* includes all participants actively involved in the product development such as game designers, programmers, graphic artists, level designers, etc. All developers contribute with their personal experiences and expertise to the project. Due to the high fluctuation of participants between development teams or departments it becomes eminently important to give insight into the individual knowledge of the team members of a project to prevent a loss of knowledge when a member leaves the team.

The *publisher* is responsible for the finance, placement, marketing, and distribution of the game. Besides the continuous dialogue with the developers, all knowledge intensive processes converge at the publisher making it possible to launch a product successfully. The coordination of marketing and public relations, the localization of a product for different markets, and the organization of the distribution are only a few examples for these processes.

Increasing project sizes cause a stronger involvement of outsourcing *partners*. This cooperation requires a particularly intensive form of knowledge exchange since it is essential to create a shared understanding of the project and to ensure that all externally developed components fit seamlessly into the overall product. Furthermore, the adjustment of the game to the current and future hardware demands an active knowledge exchange between game developers and hardware producers.

The *community* that gathers around published or announced game products is characterized by a high activity and a huge engagement when it comes to the critical review or discussion of a game or ideas for improvements and new features. There are numerous well-established community portals, boards, and weblogs that focus on digital games (e.g., Gamespot<sup>3</sup>, IGN<sup>4</sup>). Thus, we consider it valuable to integrate the community as far as possible in the development process in order to gain new ideas, helpful suggestions, and feedback from outside (use of the *wisdom of the crowds* [Surowiecki 2004]). Some projects go as far as to give away basic decisions of the game design to the community and let the game fans actively participate in the development process (an example is the project *Top Secret*<sup>5</sup>).

The group of *media representatives* consists of journalists, editors, and producers who work for media formats in the area of digital games. Often, members of this group get the chance to test an early version of the game in order to prepare previews. The feedback of these previews is of great importance for the developers because the journalists are often the first external persons to see and play the game. Due to their broad experiences with digital games they often give valuable advice regarding bugs or weaknesses of the prototype game version.

Furthermore, *external experts* are involved in the project to assist the developers, for instance, when it comes to pedagogical or child-welfare issues. It is of great importance to the developers and publishers to receive early feedback on possible obstacles regarding age restrictions in order to still have an influence on changes. A high age rating (e.g., 'Mature' or 'Adult-Only') can have a negative impact on the sales numbers of a game and is an important factor for the calculation of a publisher. In addition, pedagogues might support the developers in designing games for special target groups in the areas of serious gaming [Michael and Chen 2005] and game-based learning [Prensky 2007].

---

<sup>3</sup> One of the biggest game portals for the American and European market – see <http://www.gamespot.com>

<sup>4</sup> Big American and British portal for interactive entertainment and new media – see <http://www.ign.com>

<sup>5</sup> *Top Secret* is a massive multiplayer online racing game which is developed under the lead of David Perry together with about 60.000 community members.

## 4 Continuous Integration of Knowledge Management

Against the background of the described dimensions of integration, we work on a solution approach in the context of the *SoftWiki* project<sup>6</sup> that supports knowledge management on three distinct levels: by a central knowledge repository, embedded feedback channels, and knowledge extraction mechanisms. In the following, we briefly describe these levels of support and illustrate our approach by means of tools we are currently developing within the project.

### 4.1 Central Knowledge Repository

A knowledge repository forms the central access point for all knowledge management activities. Our approach builds on the open-source framework *Powl* and the corresponding collaboration platform *OntoWiki*<sup>7</sup>. In cooperation with the department for Business-oriented Information Systems (BIS) of the University of Leipzig, we are working on an extension of this collaboration platform with the needs of game development in mind (see Figure 2a). Following the Wiki philosophy [Leuf and Cunningham 2001] the user interface allows intuitive, web-based editing of the game project's knowledge base and provides different access options and views. Besides the developer team, the publishers and partners have separate access rights and are enabled to adapt and update specific parts of the knowledge base. Among others, mechanisms for consistency checking and versioning as well as for voting and semantic search are provided.

In addition, the knowledge repository implements interfaces for syndication and further processing of parts of the knowledge base (such as web services and newsfeeds). That way a developer weblog (see Figure 2b) or mailing list can be easily connected to the repository. The other way around, external knowledge (e.g., provided by hardware producers) can also be easily integrated via appropriate interfaces according to the access rights. We work on an ontological schema that defines basic concepts regarding game development in order to enhance data exchange and semantic interoperability. Since digital games are a very fast-moving domain, we consider in particular easy adaptability and extension in all areas of development support.

### 4.2 Embedded Feedback Channels

The central knowledge repository is extended by decentralized feedback and communication channels that can be embedded directly into the development or run-time game environments. The general aim is to elicit feedback of users while

---

<sup>6</sup> Research project, funded by the German Federal Ministry of Education and Research (BMBF) - <http://softwiki.de/>

<sup>7</sup> <http://ontowiki.net/>

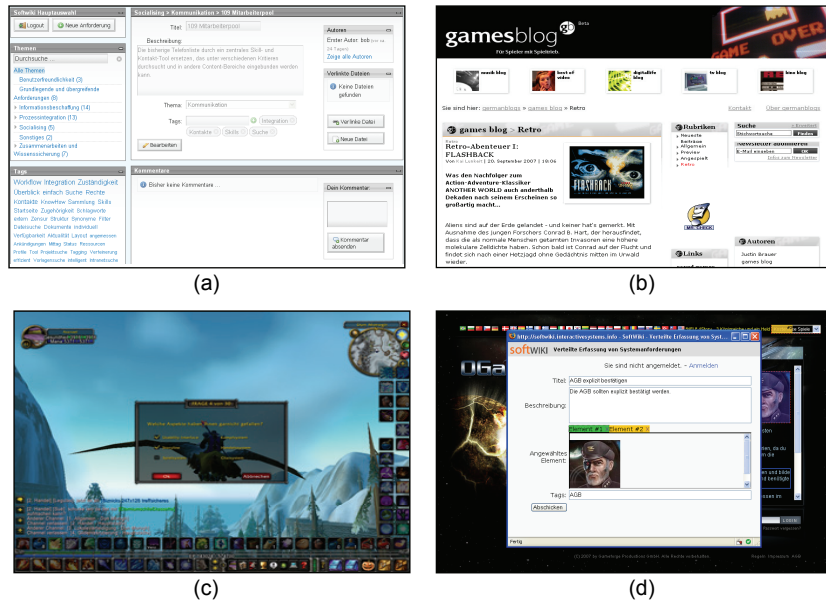

Figure 2: Examples of knowledge management support for game development.

they interact with the applications. Depending on the environment and state of development, different user groups (e.g., the QA-team, gamers, third-party experts, etc.) must be provided with adequate feedback channels. Furthermore, it must be defined if the user should give feedback in a self-directed way (e.g. when it comes to his mind) or if he is explicitly asked for feedback in certain situations.

Figure 2c shows an evaluation tool we implemented in the scripting language LUA [Jerusalimschy et al. 2007]. It can be seamlessly integrated into the game environment – in this case, the online game *World of Warcraft* (WOW)<sup>8</sup> – and enables event-based capturing of feedback within the game world. Figure 2d shows an alternative realization we implemented for web browsers based on web technology and the user interface markup language XUL [Feldt 2007]. It can be used to elicit feedback on browser games: If a bug or feature request occurs, for instance, the user presses a button in the web browser and a web form opens where he can enter a description of the bug or feature request.

### 4.3 Automated Knowledge Extraction

A third form of knowledge management support in our approach are automated knowledge extraction mechanisms. On the one hand, these mechanisms assist

<sup>8</sup> see <http://www.worldofwarcraft.com> or <http://www.wow-europe.com>

in using and analyzing the knowledge stored in the central repository. On the other hand, they can be used to augment the repository by externally available knowledge. For instance, we aim to develop intelligent agents that crawl the web for relevant content in community portals, discussion boards, newsgroups, and weblogs. Due to the increasing use of XML- and RDF-based formats for content representation, automated discovery and processing is facilitated.

## 5 Conclusion

We tried to point out that continuous integration of knowledge management into the development process of digital games is not only crucial for the success of large projects but also results in several benefits. These include easier adherence to the timetable and lower dependency on the knowledge of individuals reducing the risks and costs of development. Furthermore, continuous knowledge management facilitates the development of game series and secondary or downstream exploitation, for instance, if a similar game structure or the same game engine are used again. Besides its function as documentation, the knowledge base can also serve as a source of inspiration for subsequent projects. Our future work includes further development of the presented tools and their application in game development projects.

## Acknowledgements

We thank our colleagues at the University of Leipzig, Thomas Riechert, Frank Schumacher, Sebastian Dietzold, and Sören Auer, for their input on this topic.

## References

- [Feldt 2007] Feldt, K.C.: “Programming Firefox: Building Rich Internet Applications with XUL”; O’Reilly Media (2007)
- [Ierusalimschy et al. 2007] Ierusalimschy, R., de Figueiredo, L.H., Celes, W.: “The Evolution of Lua”; HOPL III: Proceedings of the 3rd ACM SIGPLAN Conference on History of Programming Languages, ACM (2007)
- [Leuf and Cunningham 2001] Leuf, B., Cunningham, W.: “The Wiki Way: Quick Collaboration on the Web”; Addison-Wesley Longman (2001)
- [Michael and Chen 2005] Michael, D.R., Chen, S.L.: “Serious Games: Games That Educate, Train, and Inform”; Thomson Course Technology (2005)
- [Prensky 2007] Prensky, M.: “Digital Game-Based Learning”; Paragon House Publishers (2007)
- [Rollings 2003] Rollings, A., Morris, D.: “Game Architecture and Design: A New Edition”; New Riders (2003)
- [Saltzman 2003] Saltzman, M.: “Game Creation and Careers: Insider Secrets from Industry Experts”; New Riders (2003)
- [Surowiecki 2004] Surowiecki, J.: “The Wisdom of Crowds: Why the Many are Smarter than the Few and How Collective Wisdom Shapes Business, Economies, Societies and Nations”; B&T Press (2004)

# **Success and Failure Factors for KM: The Utilization of Knowledge in the Swedish Armed Forces**

**Ulrica Pettersson**

(Swedish National Defence College, Stockholm, Sweden  
ulrica.pettersson@fhs.se)

**Abstract:** Developing successful knowledge management (KM) processes is extremely difficult. In general, a large number of all KM projects end unsuccessfully. The aim of this paper is to summarize and study the attempts to take advantage of Lessons Learned in the Swedish Armed Forces (SwAF), focusing on international missions. Relevant reports, articles and literature have been studied. With the purpose of understanding the reasons for failure and the failure factors in SwAF's attempts at KM, Chua and Lams' model for unsuccessful KM implementation has been applied to four cases from the organization. The results show that SwAF are aware of the importance of knowledge and have attempted to implement KM on several occasions. In most cases, however, the KM projects do not achieve widespread use and eventually end unsuccessfully. Furthermore, many of the KM tools that have been developed are no longer in use. The Swedish Explosive Ordnance Disposal and Demining Centre (SWEDEC) and the Swedish Air Force are notable exceptions.

**Keywords:** Knowledge Management, Lessons Learned, Evaluation of Knowledge Management

**Categories:** H.3.3, H.4.3, H.5.3, J.7

## **1 Introduction**

Developing successful knowledge management (KM) processes is a difficult task. According to Lucier, up to 84 percent of all KM programs generally fail [Lucier 2003]. Although there has been extensive research in the KM field, it is still complex and difficult for practitioners to implement KM in organizations. During the last decade, the Swedish Armed Forces (SwAF) have tried several ways, on multiple occasions, to implement KM in different parts of the organization. The majority of attempts unfortunately ended unsuccessfully, with the Swedish Explosive Ordnance Disposal and Demining Centre (SWEDEC) and the Swedish Air Force as exceptions. Today, the cost of KM project cancellations is considerable and represents missed capacity through the loss of a large number of Lessons Learned. Some of the failure factors we will present in this paper were noted in a report ten years ago [Lindgren, Almén, Rindstål 1998]. Although this problem is well known in SwAF, we have only found one study [Lindgren 1998] and no official reports about the reasons for the repeated mistakes. This work focuses on Lessons Learned from international missions and how this knowledge is managed in the organization. We have used Chua and Lams' model for unsuccessful KM implementation to identify the KM failure factors in four cases.



The goal is to understand why SwAF has ended up with the same dilemma over and over again.

## 2 Background – Learning from and Making Use of Experiences

Waltz [2003] observed that KM requires coordination between *people, processes* and *technology*. Through collaborative learning and problem solving, culture and organizational structures are expected to enable and inspire the growth of knowledge. The organizational environment must provide acceptance of and the opportunity for exchange, use and reuse of knowledge [Waltz 2003].

Argyris [1965] emphasized action in the learning process. Learning occurs every time a mistake is observed and corrected, and the mistake is defined as an occasion with conflicts between consequences and intention. He also emphasized the difference between *experience* and *learning from experience*. There is no guarantee that an individual learns something simply through a unique experience [Argyris 1965]. A study made by Löfstedt and Rode [2007] showed that several independent sources verified that it is not permitted to discuss mistakes in the SwAF. There is a pronounced fear/anxiety that such discussions would damage an individual's career. *“Knowledge is not just about success stories. If you can encourage employees to record their mistakes with no fears of further action, you will be able to build a truly useful knowledge repository. With it your organization will be less likely to repeat previous mistakes and able to make decisions quicker”* [Lucier 2003, page 3]. In general there can be an unwillingness to admit mistakes and blunders for fear of punishment and exposing one's educational level. Knowledge is also a platform for an individual's career and position in an organization [Ölçer 2007]. This situation often prevents knowledge flow and keeps knowledge isolated among one or a few individuals. However, there are notable exceptions in parts of the SwAF organization. SWEDEC and the Swedish Air Force have traditionally invited dialogue about experiences to increase safety within units. These exceptions may be because individuals in these units truly understand that the Lessons Learned effort can save lives — their own and their colleagues. The Swedish Air Force even accepts anonymous reports [Löfstedt, Rode 2007]. Developments in techniques and aircraft are other reasons why the Swedish Air Force has managed to lower the frequency of accidents.

Before Lessons are transformed into Lessons Learned and can be considered as reliable knowledge, they must be handled systematically. There should be discussion and critical consideration about which Lessons highlight requirements for improvement, and there must be a working system for documentation of this process. In this paper, some cases will show that Lessons managed to reach and be filed in the KM systems, but got no further. SwAF tend to miss the utilization part in the KM process.

### 2.1 Reasons for KM Failures

According to Chua and Lams' model of unsuccessful KM implementation [Chua, Lams 2005], there are four distinct categories of failure factors: technology, culture, content and project management.

The first and most pronounced factor is blind faith in technical solutions such as the KM infrastructure, technology and tools within the KM implementation group. Failures in this category can occur when those KM tools developed have poor usability and users find the tools complicated to use. Connectivity problems arise when the technical infrastructure has limitations, such as insufficient bandwidth or problems with network connectivity. Over-reliance on KM tools can contribute to human issues and tacit knowledge being ignored.

The second category is culture, including human and organizational behaviour. The failure factors in this category include for example politics, when KM is used to gain control and authority within the organization. Lack of management commitment and withdrawal of commitments during the KM process are other examples of failure factors. Perceived image refers to accessing others knowledge, which is perceived as a sign of inadequacy or insufficiency, by the users.

The content category includes characteristics of the knowledge itself. Failure factors can be lack of knowledge structure, which makes the content meaningless and difficult to understand for the users. Relevance and currency, the content does not meet the user's needs. Difficulties in distilling valuable knowledge from organizational processes are addressed as knowledge distillation.

The fourth and last category, project management, includes the following failure factors: Lack of user involvement in the KM project can result in a misunderstanding of the users' actual knowledge requirements. During KM implementation, individuals may move in the organization, relocate, or resign. Reorganizations can result in a shortage of technical and business expertise for the maintenance and use of KM tools. There is no ready-made plan for project evaluation, to track and measure achievement in the project.

Chua and Lams' model divides each case into a three-step cycle: initiation, implementation and integration [Chua, Lams 2005]. This has not been done in our study due to previously insufficient documentation of each case.

### **3 Method**

This descriptive literature study builds on four cases from the SwAF. Three cases were found in the Swedish Defence Research Agency's (FOI's) database, as a result of a search for documented reports on project, focusing on experiences and Lessons Learned during international missions. One case was found through talking to staff of the Information section for The Swedish Armed Forces Network and Telecommunications Unit (FMTM). In addition, relevant KM-reports and articles found in the databases of Emerald and IEEE Xplore have been read. A search in Jane's Defence Magazines Library, however, gave nothing applicable. To identify the KM failure factors we found and decided to use, Chua and Lams' [2005] model for unsuccessful KM implementation, published in *Journal of Management* Vol 9 No 3 2005.

## **4 Result - Technical Solutions for Lessons Learned**

During the last decade there have been several attempts, in some divisions of the SwAF, to collect, analyse and categorize experiences, followed by development of technical support systems. In this section, we summarize these attempts and their outcome. Note that this summary only covers KM efforts by the SwAF.

### **4.1 Heimdall**

Until 2000, the Swedish Armed Forces International Centre (SWEDINT) and the Joint Forces Command (OPIL), now Operational HQ (OPE), used a database named Heimdall. This database was designed to contain a significant number of lessons from completed international missions. The main purpose was to keep one centralized database that allowed personnel throughout SwAF to access it. The database was developed using Microsoft Access, which - unfortunately - later turned out to be software not approved for use within the SwAF [Löfstedt, Rode 2007].

Regrettably, personnel in ongoing missions could not access Heimdall because of security restrictions. One major dilemma in the project was the lack of acceptance for the entering of data into the database, as a natural sub-task for users. Users did indeed enter data, although with great resistance and only in exceptional cases [Löfstedt, Rode 2007]. Users were able to enter data into the database, but they did not experience any connection between the data-entering process and the benefit of the system to their daily work. This situation was the primary reason for Heimdall eventually being closed down. Furthermore, there were obvious problems with the user interface and the general usability of the system. Different aspects of the data entered into Heimdall were categorized to make it easier to search for relevant information. Supplementary data could be added voluntarily under sub-headings [Lindgren, Almén, Rindstål 1998].

### **4.2 HTML Help Workshop**

In 1999 the Swedish Navy started to distribute the LLDB99 database. It was primarily a collection of experiences written down from military exercises carried out in 1996/1997. A few years later, it was expanded to include lesson-learned reports from additional exercises and was renamed LLDB 2000 version 1.0 [Ranhagen 2001]. The software was already in use by some units in NATO and the US Navy and, furthermore, it was free to download.

This case indicates that there were significant problems with motivating the users to deliver reports, enter data and search for data in the database [Löfstedt et al. 2007]. They could not perceive the connection between input (data entry) and output (searches). This was the main reason why the system was finally closed down. In addition, an extensive reorganization, which resulted in the loss of a lot of knowledge and technical know-how about HTML Help Workshop, contributed to the decommissioning of the system. OPIL also used an earlier variant of HTML Help Workshop named Win HLP; this was closed down for the same reasons.

### 4.3 Lessons Learned Information Management System

SWEDEC is a centre of excellence in the field of ordnance disposal and mine clearing, which cooperates with the Swedish Police, the Swedish International Development Cooperation Agency, and international organizations such as the International Test and Evaluation Program and the Geneva International Centre for Humanitarian Demining. FOI has developed the Lessons Learned Information Management System (LLIMS) for managing codified knowledge, ordered by SWEDEC. The lessons-learned process and the analysis function are high priority activities at SWEDEC. The aim of the lessons-learned process is to disseminate new knowledge to the organisation. This can be achieved through transformation of observations made by individuals or groups, into reports in the system [Samuelsson 2006]. The system is also used by the Maritime Warfare Centre (SSS) in an attempt to develop a common experience database within SwAF [Löfstedt, Rode 2007]. After completed missions the Lessons are analysed and entered into the LLIMS system, where they are accessible to, for example, future mission planners. LLIMS is searchable in several dimensions such as mission, unit identity, report authors, creation date, and document identity [Samuelsson 2006]. To acquire knowledge proactively, SWEDEC arranges seminars that focus on mission experiences, and also participates in seminars at the Swedish Rescue Services Agency (SRSA) and other organizations in the field of ordnance disposal and mine clearing. Furthermore, SWEDEC supports a NATO program (National Armament Directors Programme of Work – Defence against Terrorism Explosive) by supporting Slovakia in its efforts to build up an Explosive Ordnance Disposal (EOD) centre.

### 4.4 Technical System Support

FMTM is a joint unit located in several places in Sweden. The unit is responsible for SwAF stationary Command, Control and Communications (C3) systems, which are supervised from the C3 Operations Centre. Operational readiness tasks are given by the Joint Forces Command in the SwAF alert order, where the actual operational readiness levels are settled in different areas, such as different networks, radios, sensors and SATCOM. Some units in FMTM have extensive service-desk activity and maintain large systems for the logging of not only incidents but also solutions. Unfortunately, there are no overarching directives for what sort of system the divisions should procure and maintain. Therefore, there is no general overview or coordination of the systems and it is difficult to exchange information. There is also lack of acceptance among some users, to enter and search for data in the database. These databases are mostly designed for technical incidents, but they have the capacity to store different kinds of incidents and solution such as administration and management concerns. Unluckily they are not used for a KM purpose and Lessons are never actually developed into Lessons Learned. Within these systems SwAF's security classifications cause limitations for users [Staff of Information FMTM 2006].

### 4.5 Overview – failure factors

Failure factors from our four cases have been applied into Chua and Lams' model for unsuccessful KM implementation [Table 1]. Two of the cases which we studied had

failure factors in all four categories. One case had failure factors in three categories, and the last one of our cases, we could only match into one category.

	Heimdall	HTML H. W.	LLIMS	Technical S. S.
(T1) Connectivity	✓			✓
(T2) Usability				
(T3) Over-reliance	✓			✓
(T4) Maintenance cost	✓			
(Cu1) Politics				
(Cu2) Knowledge sharing		✓		
(Cu3) Perceived image		✓		
(Cu4) Management support	✓	✓	✓	✓
(Co1) Coverage				
(Co2) Structure	✓	✓		
(Co3) Relevance & currency	✓	✓		
(Co4) Knowledge distillation				
(PM1) User involvement	✓			✓
(PM2) Tech/business expertise		✓		
(PM3) Conflict management				
(PM4) Roll-out strategy				
(PM5) Project cost				
(PM6) Project evaluation				
(PM7) External consultants				

Table 1: Overview of SwAFs project in, Model for Unsuccessful KM Implementation (T)=Technical, (Cu)=Culture, (Co)=Content and (PM)=Project Management

## 5 Discussion

To avoid over-reliance on technical tools, the technology itself must be separated from the problem that it is supposed to address. The Swedish Air Force managed to deal with many aspects of Lessons Learned, even before the first KM concepts with technical solutions were implemented in the organization. Technology should be considered as human artefacts that support the function/task to be achieved [Brehmer 2007]. The Swedish Air Force undertakes high-risk tasks that tend to highlight the need for forthrightness. Imminent danger and the threat of injuries and fatalities seem to bring out an open culture, where individuals can share experiences seriously and meaningfully, without fear of the consequences. It seems that the Swedish Air Force management was the first in SwAF to understand and encourage this culture.

The security classification schemes in SwAF limit both access to data for users and transmission of data between different systems. This relates directly to the availability factor, which gives rise to accessibility dilemmas at the time of request. If KM tools have poor usability, in terms of time and place, users tend to lose interest and motivation. We believe that the key to reducing these recurring problems is a systematic implementation of KM. SwAF must utilize past experiences and ensure that Lessons actually result in Lessons Learned, with the aim of reducing friction in the organization. This can be achieved by a genuine effort to create and maintain a

culture of openness and honesty. Management must take full responsibility for the implementation of a KM process, which focuses on the users and their needs. In addition, all attempts should be carefully documented.

## **6 Conclusions**

In three of our four cases KM implementation ended unsuccessfully; SWEDEC turned out to be an exception. It appears that the same mistakes were made repeatedly, and in the first three cases, we found a few common weaknesses: a multitude of actors, weak central management, insufficient KM tools, and no account taken of user needs [Lindgren, Almén, Rindstål 1998, Löfstedt, Rode, 2007, Ranhagen 2001].

The first and most important failure factor is that information does not meet user needs. Secondly, culture prevents individuals from admitting mistakes and blunders for fear of the consequences. Thirdly, there are difficulties to progress from the Lessons and thus actually obtain Lessons Learned, with the aim of reducing friction in the organization. Fourthly, the attempts at KM are not systematized or well documented.

Fifthly and finally, central management does not take full responsibility for the processes.

The key to avoiding repetition of the same mistakes is to systematize and document KM attempts accurately. KM processes must also be implemented with a holistic view that includes individuals and their needs, from the outset. Another challenge is to create and maintain a learning and knowledge-oriented environment, in a culture that encourages openness and honesty. SWEDEC has been successful in that matter, and we consider that it is possible to do so even in other units. If there is an obvious risk for injuries, users seem to be more motivated to enter and search for data in the KM system. Despite the risks, we believe that this indicates that it is possible to educate and work with human aspects in a more extensive way than it is done today. It is important that the user obtains insight, understanding and knowledge of their importance in the KM system. Rewards for active efforts in KM works and acceptance of anonymous reports among users can be a start [Guptara 1999]. Future KM projects should analyse and learn from the culture in SWEDEC and the Swedish Air Force. Central management needs to take full responsibility for the whole KM processes. Wherever future missions may be and whatever tasks may be undertaken, we are certain that some experiences from the past can be utilized; Lessons can be transformed into Lessons Learned and lead to improvements in future SwAF missions.

## **References**

[Argyris 1965] Argyris, C.: "Personality and Organization. The conflict between system and the individual"; Harper & Row / New York (1965). [Brehmer 2007] Brehmer, B.: "Understanding the functions of C2 is the key to progress"; *The International C2 Journal*, 1, 1 (2007), 211-232.

- [Chua, Lams 2005] Chua, A., Wing, Lam.: "Why KM projects fail: a multi-case analysis"; *Journal of Knowledge Management*, 9, 3 (2005), 6-17.
- [Guptara 1999] Gupta, P.: "Why knowledge management fails – How to avoid the common pitfalls"; *Knowledge Management Review*, 9, (1999), 26-29.
- [Lindgren, Almén, Rindstål 1998] Lindgren, F., Almén, A., Rindstål, P.: "Lessons Learned vid Internationella insatser - Begrepp, motiv, metoder". [Lessons Learned from International Missions – Concepts, motivation, method]; *Försvarets forskningsanstalt / Stockholm* (1998).
- [Lucier 2003] Lucier, C.: "When knowledge adds up to nothing – Why knowledge management fails and what you can do about it"; *Developed and Learning in Organizations*, 17, 1 (2003), 32-35.
- [Löfstedt, Rode 2007] Löfstedt, R., Rode K.: "Erfarenhetshandtering inom Försvarmakten – Med internationella insatser som fokus" [Handling of experiences within the Swedish Armed Forces]; *Totalförsvarets forskningsinstitut / Stockholm* (2007).
- [Staff of Information FMTM 2006] Informationsstaben, FMTM / Örebro (2006).
- [Samuelsson 2006] Samuelsson, L. <http://www.swedint.mil.se/article.php?lang=E&id=13618> (20080122), <http://www.swedec.mil.se/article.php?id=11385> (20080116).
- [Ranhagen 2001] Ranhagen, O.: "Marinens lessons learned process" [The Navy's Lessons Learned Process]; *Totalförsvarets forskningsinstitut / Stockholm* (2001).
- [Waltz 2003] Waltz, E.: "Knowledge Management in the intelligence enterprise"; *Mass Artech House cop. / Boston* (2003).
- [Ölçer 2007] Ölçer, F.: "Practices of Knowledge Management in Companies: A Turkey Survey"; *Proc. I-KNOW'07, Graz* (2007).

## **Knowledge Barriers in CD&E Projects in the German Federal Armed Forces**

**Eva-Maria Kern, Michael Koch, Carolin Fiechter, Alexander Richter**  
(Bundeswehr University Munich, Germany)  
eva-maria.kern | michael.koch | carolin.fiechter | alexander.richter @ unibw.de)

**Abstract:** Project organizations make particular demands on the management of knowledge both within projects and across projects. In this contribution we present a method kit for the improvement of knowledge management in a project organization in the German Federal Armed Forces. The kit was developed in an interdisciplinary cooperation with the Bundeswehr University Munich. The project team approached two goals: The method kit firstly should serve as an instrument for a target-oriented identification and for removing project specific knowledge barriers. Secondly, the kit should create awareness for measures to further support knowledge work. We describe the basic elements of the method kit and present a process model for its application.

**Keywords:** knowledge management, knowledge barriers, project organization

**Categories:** H 4.3, H 5.3, M 8

### **1 Knowledge management in small project organizations in the German Federal Armed Forces**

The German Federal Armed Forces are facing new challenges in the context of a significant shift in their responsibilities and simultaneous improvements in weapons and information and communication technology. To constantly improve and to maintain its capabilities the German Federal Armed Forces therefore have codified "transformation" as superior principle for an extensive and continuous reorientation (Schäfer 2006).

An essential element of the transformation process is the method Concept Development & Experimentation (CD&E). The basic idea of CD&E is an iterative development process that changes between phases of (theoretical) concept development and (practical) experimental evaluation (Schäfer 2006). Thus, the method can be compared with different participative and prototype based development methods in software and systems development (see e.g. Kensing and Blomberg 1998 or Holtzblatt 2002). Following the basic idea the implementation of the method is performed in the form of projects with participation from concept developers, users from the practice and evaluators. Due to novelty and complexity of these projects an essential requirement for a successful execution of the projects is the development of new knowledge in teams, the exchange of knowledge between team members and other involved partners across the project stages, and the purposeful usage of existing knowledge. Project-relevant knowledge can come from already finished or parallel projects or from external experts. In summary, knowledge management is a core issue in CD&E projects.



Three groups at Bundeswehr University Munich have joined in an interdisciplinary project that aimed at the development of a modular method kit for improving knowledge management in CD&E projects. In this development a particular focus was set on overcoming knowledge barriers. We define these as circumstances and conditions that hinder the generation of new knowledge, the representation of knowledge or the exchange of knowledge between co-workers.

In this contribution we present a method kit for identifying and overcoming knowledge barriers and a process model to implement that method kit. The first step in presenting this method kit is to show how we have collected a catalogue of knowledge barriers in CD&E projects (Section 2). Based on this catalogue we then show how barriers in a particular project (organization) can be identified and removed. Therefore we introduce a process model and illustrate it with several examples (Section 3). In Section 4 we conclude with a brief resume and an outlook to possible usage scenarios for the method kit.

## 2 A structured catalogue of knowledge barriers

The starting point for the development of an instrument for addressing knowledge barriers is a comprehensive structured presentation of all knowledge barriers that are relevant in the application domain.

Bick et al. (2003, p.38) distinguish two possible methods to systematically examine knowledge barriers: The empirical examination on the basis of studies (1) and the deduction of analytic systematization approaches that try to classify the barriers in different categories (2). We have combined both methods for developing our catalogue of knowledge barriers.

First we have conducted several interviews in CD&E projects with a focus on issues of the area of organisational psychology (see Kremser 2007). In those interviews with different actors working for or with CD&E projects on different hierarchical levels, 29 different barriers could be identified and later be condensed into eight interconnected classes of barriers. Simultaneously to the evaluation of the interviews, we conducted a comprehensive literature analysis where in total more than 100 (partially overlapping) barriers could be identified (see e.g. Hoffmann et al. 2007 Bender and Diehl 2005, Probst et al. 1998, Rümmler 2001, Lugger and Kraus 2001). These barriers were slightly aggregated, put into the context of the CD&E project organization, and reconciled with the findings of the interviews. In total, 46 particular barriers could be identified this way.

For the purposes of our study we decided not to merge similar or related knowledge barriers that are still distinguishable: Thus, our method kit allows addressing the identified barriers more precisely and more efficiently by choosing specially tailored measures.

In order to categorize knowledge barriers, several systematization approaches can be found in the relevant literature (cf. Richter 2007; Eberle 2003).

One well known possibility to classify the knowledge barriers is the TOM model – using the three categories technology, organization, and man (Bullinger 1997). This classification does not guarantee full discriminatory power. But, that does not have to be a drawback, as it supports the holism of the approach: The sustainable success of a

technical solution is not possible without the adaptation of the organization and the willingness of the staff to adapt (Decker et al. 2005, p.22).

In our study we have chosen to slightly adapt the TOM model by distinguishing between individual and group in the dimension of man. This additional differentiation evolved from our analysis of the interview data, and is particularly needed to distinguish communication and motivation barriers. Hence, we distinguish four different categories of knowledge barriers:

- *Individual knowledge barriers* refer to the ability and willingness of the single project members to pass on knowledge and to adopt knowledge.
- *Group knowledge barriers* refer to conflicts in interpersonal interaction and communication.
- *Organizational knowledge barriers* originate from the organizational culture, from the organizational structure and the process organization of the company as well as from the working conditions.
- *Technology related knowledge barriers* address the relevance of the available technology and the abilities to use the technology.

Within the different categories the knowledge barriers can be clustered into different sub-classes, according to their common fields of origin. Figure 1 shows the different categories and sub-classes we have identified in our study. For some of the sub-classes examples of the knowledge barriers comprised therein are listed.

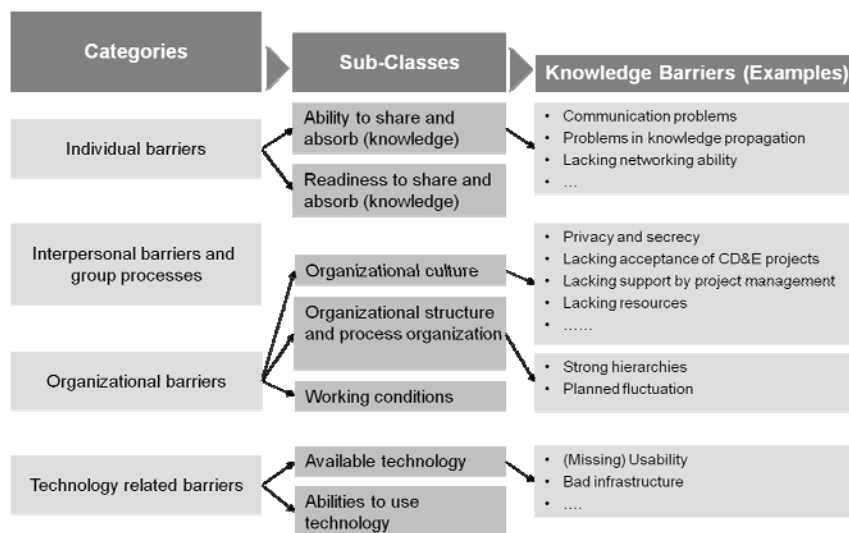

Figure 1: Knowledge barrier categories and sub-classes

With this structured catalogue of knowledge barriers, that seems to be quite generic for project organizations even though it has been derived from the application domain of the CD&E project organization, we built the basis for developing a process to address and remove the barriers.

In the following we will present the process we have developed to address these knowledge barriers in CD&E projects.

### 3 Removing knowledge barriers

The basic idea for addressing problems concerning the knowledge management of CD&E projects is depicted in the following process: First knowledge barriers are identified based on symptoms, then the barriers that have been identified and their relationships among each other are analyzed and finally particular instruments and measures for addressing the barriers are selected and implemented (see Figure 2).

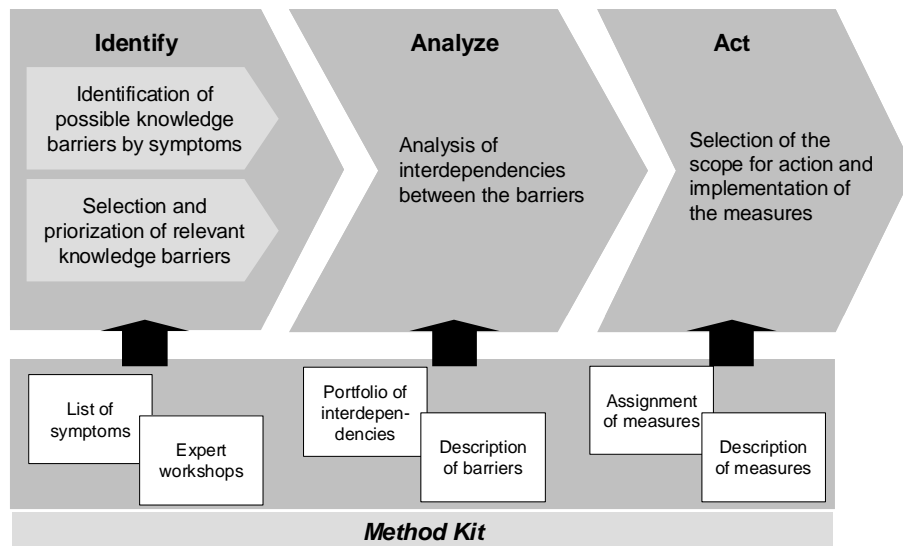

Figure 2: Overview of knowledge barrier process model

#### 3.1 Identification of knowledge barriers

The first and crucial step to address knowledge barriers is to identify which barriers apply to a particular setting. Only then effective measures can be selected and be implemented.

However, this important phase of identifying knowledge barriers has not been addressed adequately in the literature. One reason for this may be that knowledge barriers are hard to measure, and that their effect depends a lot on the particular environment and the particular organization. To allow the identification of relevant barriers regardless of these challenges we have decided to offer the users of our kit the possibility to identify knowledge barriers based on an extensive list of symptoms. The symptoms circumscribe particular situations and attitudes of team members in the context of their project work. Every symptom points to several knowledge barriers. Thereby, not all knowledge barriers that are listed with one symptom have to be relevant for the project under examination.

The symptom "Resources required for task fulfillment a not available or not available at time" for example can point to the knowledge barriers "Privacy and Secrecy", "Lacking acceptance of CD&E projects", "Lacking support by superiors" or "Lacking resources". One possibility to determine which barriers really apply is

taking additional symptoms into account: “We are not informed about current developments in our organizational unit” for example points to the knowledge barrier “Lacking support by superiors” – but also to “Lacking dialog culture”.

The goal is first to identify all potential knowledge barriers, and then to use more detailed information (workshops, expert opinions etc.) in order to reduce the initial set of barriers to those identified as significantly problematical to knowledge transfer.

The identification of knowledge barriers and the further analysis of the interdependencies among barriers is supported by a systematic description of all knowledge barriers: For every barrier the description includes a meaningful short characterization, background information, information about implications of this barrier for the handling of knowledge, references to barriers that might have interdependencies with this one and proposals of appropriate measures for removing this barrier.

### 3.2 Analysis of interdependencies between knowledge barriers

Even after having identified possible knowledge barriers and having narrowed these down to the few most important ones for a particular situation, removing them is not trivial. Organizations are complex systems that react to deterministic control in a very limited way. Every direct intervention into the system can have unintended and negative effects in addition to the intended and positive effects.

Thus we have to analyze the interdependencies between the identified knowledge barriers before starting to take measures to remove them. The analysis of the interdependencies particularly can result in recommendations which barriers have to be addressed first.

To support this analysis we provide the users of our kit with an heuristic for the division of the barriers based on two central characteristics: the influence other barriers have on this barrier and the extend of the influence this barrier has on other barriers and measures (analog to the approach of Gomez and Probst of “thinking in networks” 1997, p.72). This categorization results in four types of barriers:

- *Neutral barriers* are not or barely influenced by other barriers and do not or barely influence other barriers.
- *Exogenous barriers* are also not or barely influenced by other barriers, but influence a larger number of other barriers – so, the interdependencies are oriented away from the barrier to the outside.
- *Endogenous barriers* are the direct opposite to exogenous barriers. They are influenced by several other barriers, but do not influence other barriers themselves – so, the interdependencies are oriented towards the barrier.
- *Dual barriers* finally are influenced by several other barriers and influence several other barriers themselves. The interdependencies are oriented into both directions the same time.

It is advisable to first address the exogenous and then the dual barriers to ensure that the success of the actions that are derived from the identified knowledge barriers is influenced as little as possible from not yet addressed barriers. Ideally, after addressing the exogenous and dual barriers the endogenous and neutral barriers are almost no longer existent.

One example for the exogenous barriers identified in our project is “Lacking trust”. This barrier can influence the barriers “Leadership”, “Group dynamic effects”,

“differences of ingroup and outgroup” and “culture of withholding knowledge”. If this exogenous barrier is present with one or more of its interdependent barriers first the exogenous barrier should be addressed. Before addressing the other barriers afterwards it should be checked if these barriers still exist.

	Individual	Group	Organization	Technology
Instruments	<ul style="list-style-type: none"> <li>• Creativity and learning techniques</li> <li>• Moderation</li> </ul>	<ul style="list-style-type: none"> <li>• Creativity techniques</li> <li>• Story telling</li> <li>• Skilled discussion</li> </ul>		<ul style="list-style-type: none"> <li>• Weblogs</li> <li>• Teamrooms</li> <li>• Document and content management</li> </ul>
Measures	<ul style="list-style-type: none"> <li>• Leadership</li> <li>• Professional development</li> <li>• Lessons learned</li> <li>• Coaching</li> </ul>	<ul style="list-style-type: none"> <li>• Leadership</li> <li>• Team building</li> <li>• Inter group team development</li> <li>• Lessons learned</li> </ul>	<ul style="list-style-type: none"> <li>• Goal clarification</li> <li>• Syntegration</li> <li>• Systems analysis</li> <li>• Community of Practice</li> </ul>	<ul style="list-style-type: none"> <li>• Social Networking</li> <li>• Knowledge maps</li> <li>• Participative tool introduction</li> <li>• Process oriented tool documentation</li> </ul>
Structural changes	<ul style="list-style-type: none"> <li>• Choice of personal</li> <li>• Change of team members and/or team leaders</li> </ul>	<ul style="list-style-type: none"> <li>• Team oriented staff report</li> </ul>	<ul style="list-style-type: none"> <li>• Management by Objectives</li> <li>• Spatial Design</li> </ul>	

Figure 3: Examples for methods to remove knowledge barriers

### 3.3 Methods for removing barriers

After determining the barriers that should be addressed, one can begin with selecting the adequate measures to address them. Therefore, in our kit different courses of action are proposed for each knowledge barrier.

When discussing possible actions with our partners from praxis we found that it is helpful to classify the actions based on how quick they can be implemented and which management support is needed to implement them. In our application area we found it fitting to distinguish three different types of actions:

- *Instruments* are the simplest kind of possible actions. They can be implemented spontaneously without longer preparation and without larger resources in the context of the daily project work.
- *Measures* are comprehensive and complex actions that need some preparation and take longer to implement.
- *Structural changes* finally represent the most comprehensive category that targets long term changes in the organizational context of the project organization (e.g. by changing the organizational structure, processes or staff reporting systems).

We have collected a list of 35 courses of action, most of them in the category of “measures” (see Figure 3). Every knowledge barrier has been annotated with a list of actions that can be used to remove this barrier. From the set of possible actions that are listed for the knowledge barriers identified and prioritized in Steps 1 and 2 an organization now can select some based on its individual needs (e.g. how quick the actions should lead to results, on which level the measures can or have to be decided, etc.). The actions are therefore checked according to the following three questions:

- How can the effectiveness of the measures be influenced or decreased by existing knowledge barriers?
- In which temporal context the results of the measures will take place?
- How can the identified knowledge barriers be addressed with a minimal (personal, financial, temporal) effort?

Concerning the third question it is important to mention that the actions can support the removing of several knowledge barriers at once. So, the action “moderated dialog” can help to address “subgroups in teams”, “differences of ingroup and outgroup”, “micro politics” and “lacking dialog culture” at the same time – all in short or medium term.

## 4 Conclusion and Outlook

In this contribution we have briefly presented a method kit that we have developed to address knowledge barriers in project organizations. The main ideas in developing the solution have been:

- Collecting generic barriers from the application domain and structuring the barriers using an extended version of the TOM model
- Description of the knowledge barriers by their symptoms to allow users (e.g. project managers) to identify relevant barriers
- Collecting and structuring generic actions that can be taken to remove knowledge barriers
- Assignment of measures to knowledge barriers
- Presentation of a process model to bring the different bits and pieces together

The method kit allows to identify the knowledge barriers in a particular organizational unit and to select a matching set of actions with different time horizon and different management support needed to implement. With this tool both team and project leaders can address knowledge barriers in their groups and division managers can get suggestions for possible far reaching structural measures.

The study has been done for the CD&E project organization in the German Federal Armed Forces and has been adapted to this particular field. Thus, it remains to be examined if the approach and the sub-results are applicable for other organizations in the same way.

Since the support for the analysis of the interdependencies is only a heuristic that has been derived from relevant literature and from the experience in the application domain, in this area an empirical validation seems to be especially sensible. Also the other lists in the kit have to be validated and improved in the practical usage.

### Acknowledgements

The study we are reporting about was funded by the German Ministry of Defense (via Zentrum für Transformation der Bundeswehr) - SKZ: CE 41F 7 209 X. In addition to the authors our colleague Sonja Sackmann from Bundeswehr University Munich and her team and several students have contributed to the results. We would also like to thank our project partners at Zentrum für Transformation der Bundeswehr in Ottobrunn and at Zentrum für Weiterentwicklung der Luftwaffe in Köln (Dez Ib).

## References

- [Bender and Diehl 05] Bender, H. F.; Diehl, J. F.: Wissensmanagement im Wandel. Wissensmanagement 4/2005, pp. 10-13 (2005).
- [Bick et al. 03] Bick, A.; Hanke, T.; Adelsberger, H.H.: Prozessorientierte Analyse der Barrieren der Wissens(ver)teilung. In: Industrie management 3(3), pp. 37-40 (2003).
- [Bullinger et al. 97] Bullinger, H.-J.; Wörner, K.; Prieto, J.: Wissensmanagement heute: Daten, Fakten, Trends. Fraunhofer IAO-Studie. (1997).
- [Decker et al. 05] Decker, B.; Finke, I.; John, M.; Joisten, M.; Schnalzer, K.; Voigt, S.; Wesoly, M.; Will, M.: Wissen und Information 2005, Fraunhofer IRB Verlag, Stuttgart (2005).
- [Eberle 03] Eberle, M.A.: Barrieren und Anreizsysteme im Wissensmanagement und der Software-Wiederverwendung. Studienarbeit, TU Kaiserslautern, Fraunhofer IESE (2003).
- [Gomez and Probst 97] Gomez, P.; Probst, G.: Die Praxis des ganzheitlichen Problemlösens: Vernetzt denken, unternehmerisch handeln, persönlich überzeugen. 2. revised ed., Haupt Verlag, (1997).
- [Hoffmann et al. 07] Hoffmann, M.; Goesmann, T.; Misch, A.: Unsichtbar oder Vergessen - Wie man "verborgenen Wissensprozessen" auf die Schliche kommt. Online: <http://SunSITE.Informatik.RWTH-Aachen.DE/Publications/CEUR-WS/Vol-37/Hoffmann.pdf>. (2007)
- [Holtzblatt 02] Holtzblatt, K.: Contextual Design, The Human-Computer Interaction Handbook, Jacko, J.A. and Sears, A. (eds.), pp. 941-963, Lawrence Erlbaum Associates (2002).
- [Kensing and Blomberg 98] Kensing, F.; Blomberg, J.: PD meets CSCW - Issues and Concerns. In: Computer Supported Cooperative Work - The Journal of Collaborative Computing, 7(3-4), pp. 167-185 (1998)
- [Kremser 07] Kremser, S.G.: Wissensbarrieren bei Projektorganisationen der Bundeswehr aus organisationspsychologischer Sicht. Diplomarbeit, Fakultät für Wirtschafts- und Organisationswissenschaften, Universität der Bundeswehr, Neubiberg (2007).
- [Lugger and Kraus 01] Lugger, K.-M.; Kraus H.: Mastering the human barriers in knowledge management. In: Journal of Universal Computer Science 7(6), pp. 488-497 (2001).
- [Probst et al. 98] Probst, G.; Raub, S.; Romhardt, K.: Wissen Managen. Wie Unternehmen ihre wertvollste Ressource optimal nutzen. 2nd ed., Gabler Verlag, Wiesbaden (1998).
- [Richter 07] Richter, A.: IT-gestütztes Wissensmanagement. Theorie, Anwendungen und Barrieren, Derballa Verlag (2007).
- [Rümler 01] Rümler, R.: Wissensbarrieren behindern effektives Wissensmanagement. In: Wissensmanagement 5/2001, pp. 24-27 (2001).
- [Schäfer 06] Schäfer, S.: Concept Development & Experimentation (CD&E) - Eine Einführung. Informationsbroschüre der Luftwaffe (2006).

## **Regards about Virtual Knowledge Work**

**Mihaela Muntean**

(Faculty of Economics and Business Administration, Timisoara, Romania  
mihaela.muntean@fse.uvt.ro)

**Ileana Hauer**

(Faculty of Economics and Business Administration, Timisoara, Romania  
ileana.hauer@fse.uvt.ro)

**Abstract:** The advent of information and communication technology (ICT) provides opportunities for employees with offices in geographically dispersed locations to communicate, share and collaborate on projects to achieve common business goals. This paper describes the experiences of two Romanian telecom companies, one of them have adopted distance working as a key part of its organizational strategy.

**Keywords:** knowledge-based economy, ICT, knowledge worker, global competition, distance working, virtual collaboration

**Categories:** M.1

### **1 Introduction**

Today's economy is a knowledge-based economy where the ability to create, distribute and apply knowledge are key drivers of worker productivity, company competitive advantages, and regional and industry growth [DeFillippi, 2006]. Organizations have responded to external challenges by modifying their management practices and core business processes [Debowski, 2006].

The nature of many people's work has shifted from stable and predictable long-term careers in a particular firm or industry to a series of career paths in different organizations. The traditional psychological contract, in which an employee could assume long-term support from the employer, has changed to a general recognition that work is a temporal relationship between employer and employee.

We talk today about knowledge workers, who are dispersed around the globe and connected through the Internet. Most workers are knowledge workers at least some of the time in the work assignments that they undertake, and knowledge work is less identified by job titles than by the way people perform work. Davenport [Davenport, 2005] defines knowledge workers as having "high degrees of expertise, education and or experience". Knowledge workers create the innovations and strategies that keep their firms competitive and the economy healthy. In sum you are a knowledge worker if you work primarily with your head rather than your hands.

It seems that the economic health of regions, states and localities will depend on the proportion of knowledge worker employed, and in turn on the further learning opportunities made available to those workers [Atkinson, 2003].

Dramatic improvements in information and communications technologies (ICT) enable knowledge workers to rapidly search, collect, evaluate and transmit enormous



amounts and varieties of data and to engage in complex, collaborative work activities with anyone, anyplace, anytime. As a result, much knowledge work today arises within virtually distributed teams or networks participants.

According to Skyrme [Skyrme, 1993] there are more factors with implications in working practices. “The combination of networking technologies, global competition, market and socio-demographic factors means that the adoption of practices such as teleworking and geographically distributed teams is both practical and can give a strategic advantage “.

As results there are new valences for the work practices:

- flexible offices;
- distributed work groups;
- teleworking (distance working).

Collaboration denotes communicating and working together across organizational boundaries [Baker, 1992]. Virtual collaboration, on the other hand, refers to the use of ICT for supporting the collective interaction among multiple parties involved [Kock, 2000]. Virtual collaborations now link multiple individuals, organizations and communities in diverse industries and locales [DeFillippi, 2006]. All these participants are now collaborating on real time and customized product and service offerings that are designed, developed, tested and distributed on line. These products and services span every industry and include the provision of business, governmental and humanitarian services. Such services are limited more by people imagination and resistance to change than by any inherent limitations of virtual technologies or virtual knowledge work.

Teleworking (or telecommuting) is broadly defined [Skyrme, 1993] as using information and communications electronic networking technologies to work effectively at non-traditional 'office' locations, such as at home, on the move or in serviced offices (telecentres or telecottages). Distance working has been suggested as a solution that combines the best of the modern world with the resource efficiency and comfort of a traditional lifestyle [Sturesson, 2000].

## **2 Virtual knowledge work**

Clearly, it is now possible for more people than ever to collaborate and compete in real time with more other people on more different kinds of work from more different corners of the planet and on a more equal footing than at any previous time in the history of the world [Friedman, 2005].

### **2.1 Virtual versus physical space**

In physical space people can make face-to-face contact with one another. In virtual space there is no face-to-face contact. Instead, there is the capacity for instantaneous communication and data transfer between home to office or around the globe.

Today’s knowledge work collaborations are increasingly accomplished through dispersed project teams, whose participants work in geographically separate locations [Gibson, 2003]. Conceptually such projects can draw expertise from across the country or around the world without the problems of arranging meetings or extended

collocation. However, practically whether or not collaborators can establish and maintain necessary social interaction and ultimately function successfully together are issues that are widely discussed and not infrequently hotly debated [Kiesler, 2002]. Teams of collaborating individuals, communities and industry participants are required to navigate the virtual space in which their task or project exists.

*Advantages:*

- the ability to bring on board people from anywhere in the world at any time;
- the ability to access the most knowledgeable and competent workers;
- time zone differences allow for work to continue up to 24 hours a day;
- working peak performance periods, reducing the commute time and forming project teams based on knowledge versus location.

*Disadvantages:*

- 24 hours a day continuous virtual work assumes a high degree of coordination;
- work delays by one dispersed team can adversely affect other virtual team members' task performance;
- a barrier to 24 hours virtual work is timeliness (speed) of communications between geographically distant team members;
- if members are located in culturally diverse work settings, where language, values and social practices vary, then may appear misunderstandings.

## 2.2 Distance working

Distance working is a function that involved ICT. A Swedish study shows that 77 percent of the distance workers use computers, 46 percent can connect their computers to the company network and 72 percent have mobile phones [Haraldsson, 2007].

When deployed as part of a flexible working practices programmed teleworking has delivered these proven benefits [Skyrme, 1993]:

- more savings in office and space costs;
- more productivity improvements for certain types of work;
- reduced need for relocations with attendant employee costs;
- organization flexibility - creating ad-hoc teams with winning skills;
- retention of key skills and reduced staff turnover;
- more resilience in crisis situations (strikes, fires etc.).

Research confirms that the main barriers to success are lack of attention to human and organization factors. In the paper presented in 1993 at The European Distance Working Conference David Skyrme noted that: "The challenge is one of organization and management. For many it means having to learn new ways of designing and managing work, workers and workplaces."

## 2.3 Properties of virtual communications

The working in virtual space brings fresh opportunities and challenges, and the knowledge work participant needs to navigate this space skillfully. How this work unfolds depends in part on the communication media being used. The

communications media available for virtual knowledge work range from commonly available telephone, e-mail, instant messaging to more specialized video conferencing, intranets (covering an organization's own members), extranets (covering other outside the organization) and collaborative software or groupware technologies.

These media differ according to two key properties: 1. timelines, or speed of communication; 2. richness of communication, defined as the ability to communicate multiple cues, convey feelings, use natural language, and provide rapid feedback [Daft, 1984].

The timelier and the richer the communications, the greater is the opportunity to put people's knowledge to work.

A basic question concerns the relative merits of communications in virtual space versus physical space. Physical space benefits overall communication because it permits intense and ongoing face-to-face interactions, and more timely problem-solving and task completion [DeSanctis, 1999]. In contrast, all the communications media available to virtual work groups (telephone, e-mail, instant messaging, video conferencing, groupware) are reported to provide less "richness" than face-to-face interaction [Daft, 1986].

We will conclude that each communication media has different advantages and disadvantages.

### 3 Case Study

BlueTelecom's business is essentially managing and maintaining a network of telecom switches (telephone exchanges), each of them with thousand of customers. The company implemented eight servers, one for every geographical zone of Romania (Timis, Oradea, Bacau, Constanta, Brasov, Craiova, Galati and Bucuresti). From each management server an operator accesses up to 10 local switches situated in different geographical places, to make hardware or software changes.

The situation for one area is depicted in figure 1. In every zone were necessary at least five experts (for 24 hours shifts- 7 days/week). The training costs, for each of them, are approximately 75,000 € (three courses from beginner to expert level). The experts are trained by a major telecom supplier (Alcatel, Ericsson, Nokia, Siemens) who provided the equipment. They have to know the hardware configuration for each card, shelf, rack, also the software needed to operate (hardware and software are specific for each vendor) . The courses are offered by experts from Romania or abroad.

Each server's cost is approximately 100,000 €. Summing the all costs we have:

Final cost=8 servers (800,000 €)+ 40 experts (3,000,000 €)

Final cost=3,800,000 €

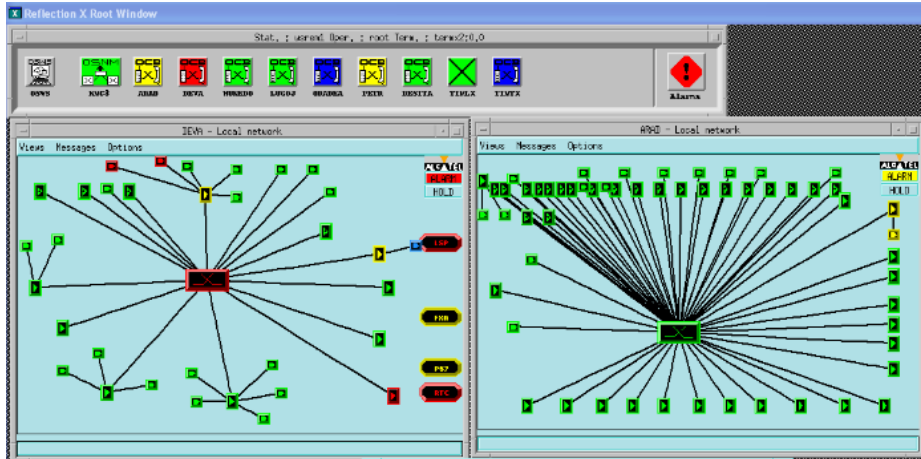

Figure 1: Example of one regional server

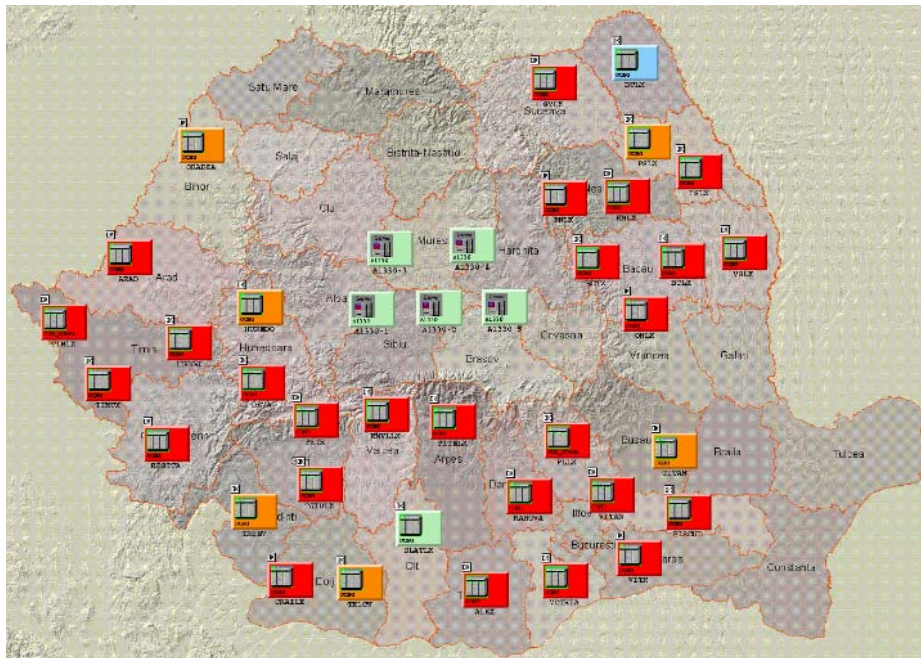

Figure 2: Example of national server

Another telecom competitor company adopted different strategy, trying to decrease expert numbers and also the server numbers. The company replaced a regional exploitation with a national exploitation, with 2 servers (one pilot, one backup). The experts can access from distance the central server for interventions in

every zone. The situation is depicted in figure 2. Also, the intervention of switching experts can be made from home.

Now the number of servers decreased to 2 and the number of experts to 5, with substantial reduced costs (from 3,800,000 to 575,000).

The benefits of this organizational strategy are already demonstrated. So, the access from distance (using public IP network, or public switched network) on central server saves a lot of money for companies, though the work volume is bigger and the responsibility has increased, the capital and operational expenses are reduced substantially.

## **4 Conclusions**

Since 1995, work in general, and knowledge in particular, has relied increasingly on the infrastructure that networks provide. The shift to a knowledge economy has increased the complexity of work activity. Where work once primarily occurred in physical space, with fellow workers able to directly see each other, it now frequently takes place in virtual place, where workers occupy separate locations and rely on telecommunications to bring their efforts together.

Virtual knowledge work is now widespread. The case study illustrated how the World Wide Web has created new possibilities for conducting knowledge work in virtual space. However, the possibilities of virtual space pose significant challenges of coordination and communication.

The modern workplace is characterized by highly complex interactions across the whole organization to encourage high-quality performance from all employees. An understanding of the organizational context and expectations helps employees to frame their work roles and contributions, and enables constant adaptation and response to new demands and trends at work.

There is one aspect of the modern work environment: people need to change and adapt to different work expectations, build new skills, and anticipate further challenges over time.

## **5 Future Work**

Technology has played a major role in enhancing the way people can share knowledge and expertise across companies, states and nations. A particularly challenging example of knowledge sharing occurs in virtual team. Virtual teams rely on technology to communicate and work through new ideas and to share their perspectives. In the near future we intend to analyze this significant form of collaboration (various roles of group members need to be clarified, if members need to be guided in some key processes, including building trust, valuing diversity, encouraging sharing, and identifying the key areas of collaboration which are to be nurtured, if there are culturally problems).

## References

- [Atkinson, 2003] Atkinson, R.D.: *The innovation economy: A new vision for economic growth in the 21st century*, Washington, DC, Progressive Policy Institute, (2003)
- [Baker, 1992] Baker, W. E.: *The network organization in theory and practice*. In Nohria, N., Eccles R.G., (Eds.), *Networks and organizations: Structure, form, and action* (pp. 397-429). Cambridge, MA: Harvard Business School Press, (1992)
- [Daft, 1984] Daft, R., Lengel, R.H.: *Information richness: a new approach to managerial behaviour and organizational design*, in Staw, B.M., Cummings, L.L., (Eds.), *Research in Organizational Behaviour*, vol.6, Greenwich, CT, JAI, pp.191-233, (1984)
- [Daft, 1986] Daft, R., Lengel, R.H.: *Organizational information requirements, media richness and structural design*, *Management Science*, 32 (5), pp. 554-571, (1986)
- [Debowski, 2006] Debowski, Shelda: *Knowledge Management*, John Wiley & Sons, Australia (2006)
- [DeFillippi, 2006] DeFillippi, R.J., Arthur, M.B., Lindsay, V.J.: *Knowledge at work. Creative collaboration in the global economy*, Blakwell Publishing, USA, (2006)
- [DeSanctis, 1999] DeSanctis, G., Monge, P.: *Introduction to special issue, Organization Science, special issue on "Communication Processes for Virtual Organizations"*, 10(6), pp.693-703, (1999)
- [Davenport, 2005] Davenport, Th.: *Thinking for a Living: How to Get Better Performances And Results from Knowledge Workers*, Harvard Business School Press, (2005)
- [Friedman, 2005] Friedman, T.L.: *The world is flat*, New York, Farrar, Strauss and Giroux, (2005)
- [Haraldsson, 2007] Haraldsson, M.: *Effects of distance work on the activity-travel Pattern*, (2007) On line <http://www.vti.se/EPiBrowser/hosting/Swopec%20distansarbete.pdf>
- [Gibson, 2003] Gibson, C.B., Cohen, S.G.: *Virtual teams that work*, San Francisco, Jossey-Bass, (2003)
- [Kiesler, 2002] Kiesler, S., Cummings, J.: *What do we know about proximity and distance in work groups? A legacy of research*. In P. Hinds & S. Kielser (Eds.), *Distributed work* (pp. 57-82). The MIT Press, Cambridge MA , (2002)
- [Kock, 2000] Kock, N.: *Benefits for virtual organizations from distributed groups*. *Communications of the ACM*, 43(11), 107-112, (2000)
- [Skyrme, 1993] Skyrme, D.J.: *Distance Working - The Corporate Perspective*, *Proceedings of The European Distance Working Conference*, Robinson College, Cambridge, (1993)
- [Sturesson, 2000] Sturesson, L.: *Distansarbete - Teknik, retorik och praktik*. Linköping, *Studies in Arts and Science*, Linköping University, (2000)

## **More Productive Knowledge Work**

### **A Report on a Systems Theory Based Approach to Identify Options for Higher Knowledge Work Productivity and its Applications in Business and Public Management**

**Sebastian Eschenbach**

(Fachhochschulstudiengänge Burgenland Ges.m.b.H., Eisenstadt, Austria  
sebastian.eschenbach@fh-burgenland.at)

**Bettina Schauer**

(Fachhochschulstudiengänge Burgenland Ges.m.b.H., Eisenstadt, Austria  
bettina.schauer@fh-burgenland.at)

**Abstract:** The established methods used for measuring labour productivity — originally designed for the manufacturing sector — do not fit the specific characteristics of knowledge work. We therefore propose a more appropriate understanding of the driving forces behind knowledge work productivity, focussing on process quality instead of result quantity. In a three step potential analysis, we assess (1) the knowledge intensity and then (2) current levels of knowledge work productivity with regard to typical intellectual activities such as information processing, communication, decision making, and learning, as well as organizational adaptability. The quality of knowledge work can be increased if the handling of information, communication and knowledge during these activities occurs in a systematically organised way instead of arbitrarily. Results of the analysis are then used to (3) propose both short and medium term action plans for more productive knowledge work.

**Keywords:** knowledge work, knowledge work productivity, labour productivity

**Categories:** M.9

## **1 Introduction**

In this paper we present a new method to identify potential for higher knowledge work productivity and its application. The analysis technique, which we have called “Potential Analysis” since its aim is to identify potentials for improved knowledge work productivity, consists of three major steps:

Step 1 — Knowledge intensity: Assessing the knowledge intensity of an organization’s processes and products we conclude how relevant knowledge and therefore knowledge work productivity is for a specific organization.

Step 2 — Current levels of knowledge work productivity: While most approaches towards work productivity deal with work efficiency only [see State of the Art] ours concentrates on effective standards for typical knowledge work activities.

Step 3 — Fields for improvement: The results from Step 1 and 2 allow identifying “quick wins” and a development path for knowledge management.

## 2 State of the Art

We follow Drucker's [Drucker 69] definition of knowledge work, who first introduced the term more than 35 years ago for people who deal with formal knowledge as a major part of their job also raising awareness to the relationship between productivity and knowledge: "The most valuable assets of a 20th-century company were its production equipment. The most valuable asset of a 21st-century institution, whether business or nonbusiness, will be its knowledge workers and their productivity" [Drucker 99].

In their taxonomy of methods to measure knowledge worker productivity, Ramirez and Nembhard [Ramirez and Nembhard 04] report that to date there are no effective, universally accepted, practical methods to measure knowledge worker productivity, see also [Drucker 99]. Approaches to measuring the productivity of knowledge work include input/output oriented models, as well as models that evaluate how efficiently knowledge work tasks are accomplished. The majority of these models aims at determining time standards but do not provide any information on the quality of the work done. Other methods try to enhance the efficiency of an organization by identifying and consequently reducing overhead costs. Although the approaches listed above cover aspects such as quantity and quality, costs and profitability, timeliness, customer satisfaction etc., none puts the defining task of knowledge work, the handling of rather formal knowledge [Drucker 69] at the center of attention. Among the concepts to enhance the productivity of knowledge workers most focus on the employment of IT, followed by approaches that emphasize the effects of management, culture and teams on knowledge work productivity. Others stress the importance of the workplace environment to make knowledge workers more productive [Sumanth et al. 90]. Heisig provides a survey of business process oriented approaches towards knowledge management and concludes that there still is a lack of theoretically as well as empirically founded methods that support the process oriented handling of knowledge in a systematic and methodologically sound way [Heisig 05].

## 3 The Analysis Technique

The importance of knowledge workers and their productivity when handling formal knowledge is undisputed [Drucker 99]. The Potential Analysis presented in this paper focuses precisely on the systematic handling of information, communication and knowledge. So far it has been applied to eight organisations in Austria:

- one of Austria's major financial service institutions,
- the Austrian subsidiary of a major international software company,
- a large social service organization,
- a branch of the regional government dealing with youth welfare,
- two institutes for teacher training,
- a medium sized research center, and
- an international, Austrian based machine construction business

Thus the Potential Analysis is not limited to a specific kind of business. It is carried out in three consecutive steps over a few months. However the input required by the cooperation partners is basically limited to the time needed for the interviews.



### 3.1 Step 1: Determining the Knowledge Intensity of a Business Unit

In an emerging knowledge economy, organizations have to face new challenges, which traditional management approaches are not well equipped to do. However, this does not mean that knowledge management is per se important for every organization but only when sophisticated, knowledge-based products and services are critical success factors [Willke 01].

The first objective of the Potential Analysis is therefore to determine the knowledge intensity of a business unit — in case of a small organization — or of the whole organization in order to establish if, why, and in connection with which types of activities knowledge work productivity and thus knowledge management is of special relevance. To determine the knowledge intensity we conduct a small number of expert interviews with the middle managers in charge of the products or processes in question. The knowledge intensity of a product or process is measured by:

- the extent to which a product or process depends on information and consulting (information intensity),
- the time and effort that is needed for coordination (interdependencies),
- the number of options that characterize the product or process (variability),
- the rate at which processes or products need to be adapted in order to keep a business competitive (innovation rate), and
- the necessary standard of formal education and training of the employees involved (qualification requirements).

These indicators are assessed relatively to important competitors on a simple ordinal scale as of lower, average or higher. The higher the indicators are, the higher is the knowledge intensity and thus the need for knowledge management. Both factors — the knowledge intensity of processes and the knowledge intensity of products and services — are entered into a two by two matrix. This helps to discuss the importance of knowledge management to a specific organization.

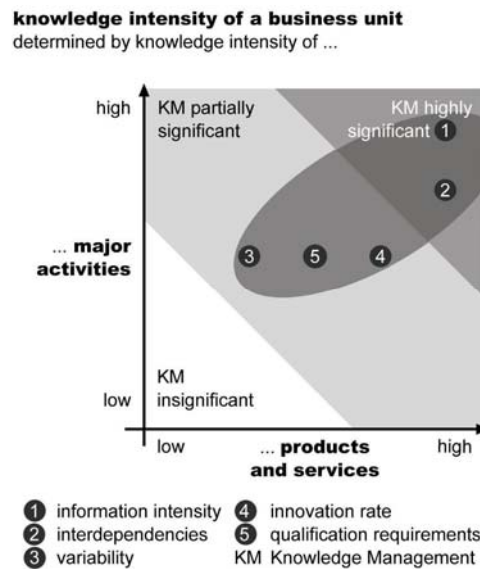

Figure 1: Example of a resulting Knowledge Intensity Matrix

The matrix is an adaptation of the Information Intensity Matrix developed by [Porter and Millar 85], which, despite its name, actually shows the importance of knowledge for an organization's major activities, final products, and services [Willke 01], see [Fig. 1]. In accordance with the often used definitions of information and knowledge by [Davenport and Prusak 00], we have consequently renamed the matrix "Knowledge Intensity Matrix". By entering the five indicators into the matrix the driving forces of knowledge intensity can be identified. [Fig. 1], for example, shows that in this case the major activities as well as the products and services are characterized by high information intensity, while variability does not have so much effect on the knowledge intensity. Therefore the first step of the analysis results in defining the focus of the knowledge management emphasis.

### 3.2 Step 2: Current Levels of Knowledge Work Productivity

Labor productivity measures the output of work. Knowledge work productivity refers to the specific characteristics of knowledge work. While in economics general labor productivity is frequently equated with efficiency [OECD 08], "[t]here is a consensus in the literature that in knowledge work, *quality* is one of the more important factors" [Ramirez and Nembhard 04].

Traditional products and services have become intelligent and knowledge-based. The knowledge inherent to these products and services is decisive for their quality and keeps organisations competitive [Willke 01]. Thus, trying to assess the results of knowledge work we believe that it is mandatory to focus on the quality of these results instead of the quantity. The more knowledge intense work gets, the more important the quality of the output becomes compared to the quantity. However in many cases it seems to be very difficult if not virtually impossible to directly assess the quality of the results of knowledge work as the definition of quality strongly depends on the individual contexts of their application [Merchel 03]. Thus, instead of assessing the quality of knowledge workers' results directly, we evaluate the quality of the activities producing these results, which is a common approach for many quality management settings, notably for the assessment of scientific research.

The fundamental basis of our analysis is Willke's systemic approach which says that the quality of knowledge work increases if the handling of knowledge occurs systematically instead of arbitrarily [Willke 01]. Thus to achieve a high process quality for knowledge work, an organisation needs to establish a system of standards or rules — to use the appropriate systems theory term — to govern key knowledge work activities. The production factor knowledge should be managed as systematically as we have learned to manage traditional production factors such as land, labour and capital; especially as knowledge is about to overtake the traditional production factors in their importance. We equate the quality of knowledge work processes with effectiveness. Whereas the quantity of the results – output per work hour – is equated with efficiency. If there are more results per working hour or knowledge work is more rule based an organisation operates in a more productive way.

$$\begin{aligned} &\text{Productivity of knowledge work} \\ &= \text{work efficiency} \times \text{effective handling of knowledge} \dots \end{aligned}$$

This is in contrast to mainstream economics where productivity is usually equated with the ratio of output and input [Samuelson and Nordhaus 04] and thus corresponds

to efficiency only. We have experienced that for many types of knowledge work, fixing standards for output and minimising input to increase productivity is just no longer possible.

Following Willke's systemic concept knowledge management [Willke 01], to find out if an organization does effectively make use of its knowledge we investigate whether a system of rules and adequate ICT for the incorporation, storage and re-using of information and knowledge exists, as well as whether the employees are familiar with these rules and observe them. We run a series of interviews applying the Critical Incident Technique [Flanagan 54] which requires that the interview strictly refers to the behaviour within specific situations — to critical incidents. Basing the interviews thus on actual incidents helps the interviewer to get accurate descriptions while personal biases and false generalizations are avoided. During the interviews, the transactions under examination are reconstructed in minute detail. The interviews focus on one or two characteristic knowledge intensive processes. However, the aim of the analysis is not to improve these specific processes but to identify deficiencies in the systematic handling of knowledge which are typical for the organisation.

At the international software company, we analyzed the preparation of a complex offer within the business unit application sales; the attendance of a debtor during the preparation of personal bankruptcy at the social service organization. The execution of care concepts for children and teenagers was analyzed at the branch of the regional government for youth welfare, similarly the preparation of teacher seminars for the forthcoming semester at the institute for teacher training.

During the interviews with the key account managers of the financial service provider, a common answer was that there were no written rules for a certain activity but that the interviewees acted as they had always done. We considered the existence of such "tacit rules" as informal rules about the handling of information, communication and knowledge. Such informal rules might work quite well. However, they cause problems whenever new employees have to be trained, and when an organization tries to systematically adapt its long established ways of handling certain activities to a changing environment. From the absence of rules, we do not conclude that every single activity has to be documented in writing. We would just like to point out that the handling of information, communication and knowledge is left to chance. The exchange of information and knowledge could, for example, also be improved by organizing regularly held, well-conducted meetings for the key account managers.

We also learned from the first application of the Potential Analysis to cluster typical activities associated with knowledge work into four major categories: information processing, communication, decision making and the adaptation of an organisation to changing circumstances — double-loop learning — each combined with the adequate ICT support. This categorization allows us to distinguish between (a) a lack of effectiveness in connection with a specific sub-activity — "a local weakness" so to say (e.g. an employee in a certain subsidiary is not yet familiar with a new guideline) and (b) a more general deficit of effectiveness, which might be typical for an organization's general approach towards knowledge work (e.g. generally rather vague rules about responsibilities, which results in ineffective, widespread up-delegations). [Fig. 2] shows the results of Step 2 of our analysis. 100% refers to the total number of questions for each category.

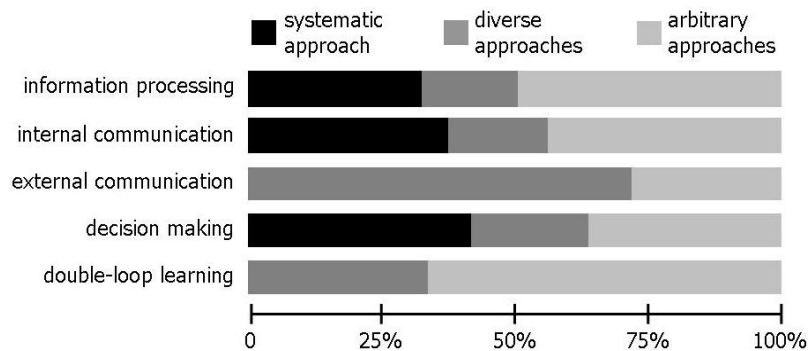

Figure 2: Results of step 2 of the Potential Analysis applied at an international financial service provider

A “systematic approach” towards the handling of knowledge refers to the case when all of the interviewees state that they know written standards on how to handle information, communication and knowledge during a certain activity and observe them. The category “diverse approaches” covers the case when some interviewees know about rules and observe them sometimes and others do not know about these rules. By “arbitrary approaches”, we mean that none of the interviewees know written standards or rules on how to proceed during a certain activity.

### 3.3 Step 3: Fields for Improvement

In the case of the international financial service provider, the results of our analysis point to two main potentials for more systematic and, according to our definition at the beginning of this paper, therefore more productive knowledge work.

#### 3.3.1 Potential 1: Knowledge Exchange about/with Customers

Despite the particularly high knowledge intensity of the customer interface [Eschenbach et al. 06], analysis of the interviews indicated a remarkable weakness precisely in this area (i.e. ineffective or unsystematic handling of knowledge). It seems that many of the account managers who work with customers on a daily basis are simply not aware of some of the guidelines (e.g. for customer communication) — a fact that came as quite a surprise to some of the headquarter managers in charge of these processes. So both the handling of knowledge about customers and the exchange of knowledge with customers leave plenty of room to further improve knowledge work productivity. This seems to be of special importance if a financial service provider tries to shift its focus from information transaction to far more knowledge intensive customer consulting activities.

#### 3.3.2 Potential 2: Double Loop Learning/Organizational Learning

The issue here is how systematically a company learns (i.e. creates and implements new knowledge). According to Willke [Willke 01], organisational learning can only take place if there are guidelines for the creation of new standards and rules, as well

as for the adaptation of the standards and rules currently valid. When we asked the product and process managers how they find out whether their guidelines and rules are not applicable in daily business, they answered that probably one of the account managers would tell them. So there seems to be no systematic procedure concerning the adaptation of rules. In reaction to these findings, some employees of the client company questioned whether in times of rapid change, management should rely on rules and other types of regulations any longer. To answer this question, one needs to see what choices organizations in a fast changing knowledge economy actually have: Certainly not the choice between a predictable and static or a changing environment, but between systematic adaptation of the organization's knowledge to new circumstances, and arbitrary reaction. The more knowledge intensive an organization is and the faster the environment changes, the louder is the call for clearly managed organizational learning on the basis of explicit knowledge.

## 4 Conclusions and Further Research

One of the questions that arise again and again is whether really everything should be standardized in detail. We have not yet found a satisfactory answer to this question. On the one hand, knowledge is today the most important production factor for many organizations. From this perspective, it definitely does make sense to organize the handling of knowledge more systematically. The deployment of other important production factors such as capital, manual labor or land is not left to chance either. On the other hand, the handling of knowledge differs from traditional production factors. While Taylor [Taylor 11], the figure head of systematic management for manual work, was convinced that for every task there is exactly one best way to solve it, this does not apply to knowledge work [Drucker 99]. Knowledge workers have to know their individual strengths, weaknesses and procedures in order to be productive. Any kind of standardization that restricts their individuality in this respect will consequently decrease their productivity. The integration of these two views will thus have to be improved in the future, as knowledge work — from an individual as well as from an organizational perspective — requires much more systematic management.

### Acknowledgements

We would like to thank Robert Hayes and Christian Schlögl for their valuable comments on our theoretical foundation, Doris Astleitner, Bernd Haselgruber, Michaela Hofer, Miranda Loibl, Stefan Pohl, Astrid Reisner, Doris Riedl, Manfred della Schiava, and Sabine Wittmann for their contributions based on applying the Potential Analysis, as well as Veronica Dal-Bianco and Marie Deissl O'Meara for proof reading.

### References

[Davenport and Prusak 00] Davenport, T.H., Prusak, L.: "Working Knowledge — How Organizations Manage What They Know"; Harvard Business School Press/Boston (2000)

- [Drucker 69] Drucker, P.F.: "The Age of Discontinuity — Guidelines to Our Changing Society"; Harper & Row/New York (1969)
- [Drucker 99] Drucker, P.F.: "Management for the 21st Century"; HarperCollins/New York (1999)
- [Eschenbach et al. 06] Eschenbach, S., Riedl, D. & Schauer, B.: "Knowledge Work Productivity: Where to Start"; In: Reimer, U., Karagiannis, D. (Eds.): *Practical Aspects of Knowledge Management; Lecture Notes in Computer Science 4333*; Springer/Berlin, Heidelberg; (2006), 49–60
- [Flanagan 54] Flanagan, J.: "Critical Incident Technique"; *Psychological Bulletin*, 51, 4 (1954), 327-358
- [Heisig 05] Heisig, P.: "Integration von Wissensmanagement in Geschäftsprozesse"; EuReKi/Berlin (2005)
- [Merchel 03] Merchel, J.: "Zum Stand der Diskussion über Effizienz und Qualität in der Produktion sozialer Dienstleistungen"; In: Möller M. (Ed.): "Effektivität und Qualität sozialer Dienstleistungen"; kassel university press GmbH/Kassel; (2003), 4–25
- [Porter and Millar 85] Porter, M.E, Millar, V.E: "How Information Gives You Competitive Advantage"; *Harvard Business Review*, 63, 4 (1985), 149-160
- [OECD 08] OECD Macrothesaurus: <http://bibliotecavirtual.clacso.org.ar/ar/oeecd-macroth/en/1729.html> Accessed 09.Jan.2008.
- [Ramirez and Nembhard 04] Ramirez, Y.W., Nembhard, D.A.: "Measuring Knowledge Worker Productivity"; *Journal of Intellectual Capital*, 5, 4 (2004), 602-628
- [Rupp 04] Rupp, K.: "Wenn der Chef nichts darüber weiß"; *Gewinn*; May (2004), 100–102
- [Samuelson and Nordhaus 04] Samuelson, P.A., Nordhaus, W.D.: "Economics" (18th ed.); McGraw-Hill/Irwin (2004)
- [Sumanth et al. 90] Sumanth, D., Omachonu, V., Beruvides, M.: "A Review of the State-of-the-Art Research on White-Collar/Knowledge-Worker Productivity"; *International Journal of Technology Management*; 5, 3 (1990), 337–355
- [Taylor 11] Taylor, F.W.: "The Principles of Scientific Management"; Harper/New York (1911)
- [Willke 01] Willke, H.: "Systemisches Wissensmanagement"; Lucius&Lucius/Stuttgart (2001)

## **A Model for Document Processing in Semantic Desktop Systems**

**Ola Leifler**

(Linköping University, Sweden  
olale@ida.liu.se)

**Henrik Eriksson**

(Linköping University, Sweden  
her@ida.liu.se)

**Abstract:** There is a significant gap between the services provided by dedicated information systems and general desktop systems for document communication and preparation. This situation is a serious knowledge-management problem, which often results in information loss, poor communication, and confusion among users. Semantic desktops promise to bring knowledge-based services to common desktop applications and, ultimately, to support knowledge management by adding advanced functionality to familiar computing environments. By custom tailoring these systems to different application domains, it is possible to provide dedicated services that assist users in combining document handling and communication with structured workflow processes and the services provided by dedicated systems. This paper presents a model for developing custom-tailored document processing for semantic-desktop systems. Our approach has been applied to the domain of military command and control, which is based on highly-structured document-driven processes.

**Key Words:** semantic desktop, document-driven processes, semantic documents, planning

**Category:** H.5.3, H.5.4, I.7.1, I.7.5, M.1, M.4

### **1 Introduction**

Information handling and knowledge communication in dedicated application systems, such as accounting and planning systems, are typically designed to support users in achieving common organizational goals. Normally, such dedicated information systems assume well-defined information processes and workflows. Conversely, there are generic desktop applications that support users in a wide variety of tasks such as communication via e-mail, document preparation through word processors and information navigation through web browsers. Such general desktop systems do not make any commitments to a particular work process.

Unfortunately, there is a significant gap between dedicated information systems and common desktop applications for everyday work. Often, users must communicate outside dedicated information systems, for example when preparing and sending documents to one another. In case users have needs for communicating or storing information that cannot be managed within dedicated

information systems, users resort to generic desktop systems. In such situations, it is difficult to keep the activities in dedicated and generic systems synchronized. In document-driven activities such as planning and reporting, where document preparation and use are core activities, it is especially important to bridge the core process of using dedicated support systems with the document authoring task and to keep the document flow manageable.

Important elements of knowledge management are document preparation, communication, archival, and retrieval. Many knowledge-intensive activities are document-driven in the sense that they focus on document authoring and document use to support human tasks such as planning, decision making, and information dissemination. Today, users take advantage of computer-based office programs such as Microsoft office and OpenOffice to create and edit documents. However, these document-processing environments mainly provide support for text-based editing tasks rather than semantic services to support knowledge management.

*Semantic desktops* are inspired by the semantic web in the sense that the semantic desktop brings semantic-web technologies to the user's desktop [Cheyer et al., 2006, Sauermann et al., 2006, Dong and Halevy, 2005]. A principal idea behind the semantic desktop approach is to support working and reasoning with semantic entities that are normally scattered across several different resources. One of the advantages of semantic desktops is that they promote both formal and informal work processes and flexible information flows. Furthermore, these systems avoid the rigid structures sometimes imposed by traditional dedicated information systems. However, without in-depth knowledge of the application domain (i.e., specific information about the content, structure, and purpose of the documents), it is difficult to provide semantic services beyond general document indexing and search.

Our approach is to extend a pre-existing semantic desktop with domain-specific functionality that enables relevant document analysis based on both the document structure (e.g., outline, tables, and diagrams) and textual content (e.g., keywords, terms, and distinguishing phrases). The development of such semantic-desktop extensions includes modeling of the document workflow, definition of domain concepts in ontologies, and implementation of document-analysis components. The implementation of extensions to a semantic desktop can involve the addition of domain-specific document tracking, indexing and visualization. Naturally, it is necessary to precede this extension development with a traditional requirements analysis identifying the relevant services that the environment should provide.



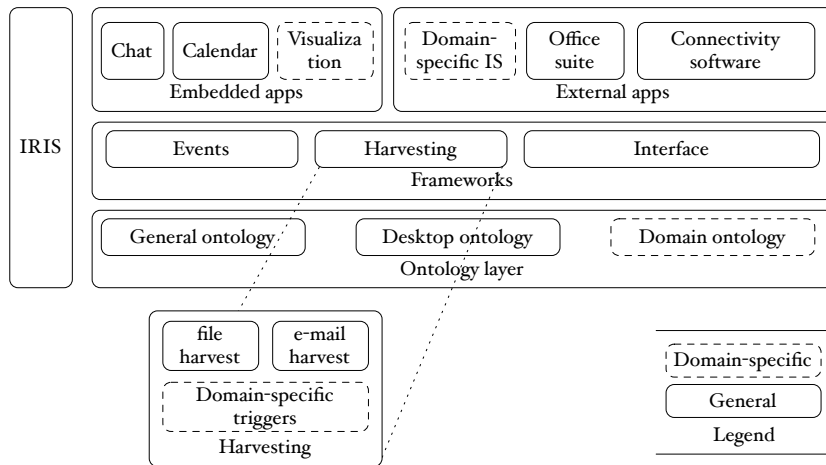

Figure 1: The IRIS semantic desktop model as a three-layered architecture with the ontology at the bottom, the frameworks used to interact with the ontology in the middle and applications at the top.

## 2 Background: Semantic desktop systems

Semantic Desktops [Cheyer et al., 2006, Sauermann et al., 2006] introduce technologies from research on the *semantic web* [Berners-Lee et al., 2001] to the computer desktop with the goal to empower users through improved information-management techniques. The semantic-desktop effort aims at managing information more intelligently through the use of powerful logical formalisms [Baader et al., 2003] for reasoning about semantic entities on the desktop.

Figure 1 presents an overview of the semantic-desktop model. It is based on the notion of an underlying formal ontology, which contains concepts and relationships that pertain to the use of a computer desktop environment. The concepts in the ontology describe interacting with applications, opening and editing files, reading e-mails etc. Also, it contains concepts that relate to semantic entities people refer to in their daily work, and which is what the semantic desktop is built to support. To give an example of such a semantic entity, we often refer to a *person*, although on a computer desktop, a person may be manifested in e-mails as the sender or recipient, in documents as the author, and in calendars as the participant in an event. All these application-specific references are identifiers of the same semantic object, however.

IRIS is a semantic-desktop environment [Cheyer et al., 2006] that contains functionality for harvesting references such as people, tasks and other common concepts from desktop resources. However, the flow of information between parts

of an organization may contain much richer semantics than that which can be described using such general concepts. Especially in highly-regulated activities, such as military command and control and medicine, additional information can be inferred from the context of work.

Like many other semantic-desktop environments, IRIS is an extensible framework where functionality can be added at all levels. To support the use of dedicated information systems along with generic desktop applications, the environment needs extensions primarily in the layers concerned with managing the ontology and ensuring that the semantics in the document flow is merged with information from dedicated information systems. The semantics of documents can be retrieved by injecting a context-aware IRIS plug-in that responds to events on the semantic desktop, such as the arrival and submission of documents via e-mail, and the creation and modification of documents. Together with a workflow model based on domain-specific documents, we propose to use semantic desktops as the foundation for new methods of merging and reasoning with information sources.

### 3 Document workflow modeling

The document flow within an organization is an important part of the knowledge-management process. Figure 2 illustrates the information flow between two levels of management. Both levels of management work in parallel to evaluate and plan activities, as well as monitor their progress and coordinate common resources. One way to characterize the interaction and workflow between these levels of management is through the documents that are created, modified, and accessed as part of the process. All traceable actions can be described as communication acts with specific senders and recipients within the organization, or with specific documents as attachments to e-mail communication. Moreover, for each specific domain, the contents of the documents communicated can be described in more detail, such as the character of the *situation brief* submitted by middle management. In the command-and-control domain, such situation briefs can contain descriptions of the current restrictions related to geographical, logistical, legal, and temporal conditions as well as medical restrictions. Also, the directive produced from upper management may contain a decision table with references to objective specifications, due dates for individual tasks, and allocated resources.

In domains where regulations or prevailing practice stipulate a well-defined structure for documents and communications, along with current trends towards standardized formats for documents such as OpenDocument and the proliferation of powerful toolkits for information extraction [Cunningham et al., 2002], a semantic desktop can be augmented with functionality that takes advantage of this structure and uses it to facilitate consistent and efficient use of information.

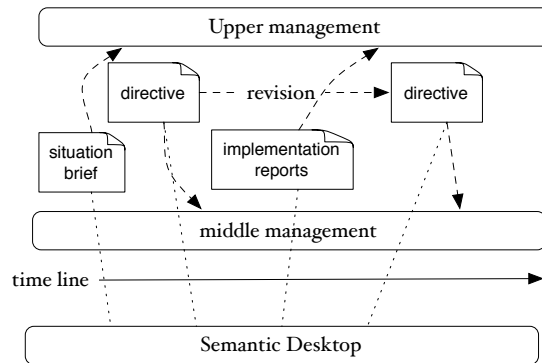

Figure 2: Document flow as part of the collaboration between two levels of management. The documents involved in this communication carry auxiliary information, such as specific file names, structured content, format, author, sender, and recipients. This type of information can assist the information-extraction process.

#### 4 Domain-specific semantic desktop information management

Recent standards in document formats (e.g., the OpenDocument and Office Open XML formats) along with advances in natural-language processing simplify the inspection of generic desktop documents. Today, it is a relatively straightforward task to recognize the structure of a document and use that structure to harvest information on its contents. In addition, natural-language-processing tools can classify words and phrases as being references to specific semantic entities, such as people and locations. Together, these advances corroborate the case for the semantic desktop as a viable support tool for knowledge management.

The use of domain-specific information can support users with reconciliation of resources, efficient information navigation, and improved communication in the following manner:

- *Reconciliation of resources* can be performed using the mechanisms already in place in semantic desktops for reifying information [Dong and Halevy, 2005], with the only addition that the source of the information must originate from the dedicated information system as well as text documents. The IRIS environment in particular is designed to act as an open platform that merges semantic references from other applications and other computers through the use of web services.
- *Efficient information navigation* can be supported by IRIS through generic views that present information about the objects on the desktop, such as

people and tasks. However, because IRIS is an open platform, it is possible to add views for displaying and navigating among references to locations, resources, teams, and so on. Furthermore, developers can connect these views to the ontology via specific events that inform each view of updates to the specific kind of semantic entities that the view manages.

- *Improved communication* can also be supported by the semantic desktop by using the shared knowledge base. The knowledge base is set up to be shared over a network, along with an event-driven architecture that provides users with notifications of changes or additions to specific categories of semantic entities.

## 5 Implementation for command and control

To demonstrate its viability, we have successfully used our approach in a military command-and-control scenario, where we harvest domain-specific location references from standard OpenOffice documents and provide navigation among those references via a map-based user interface that supports information navigation. As another example, we have identified documents with a specific structure and purpose<sup>1</sup>, and extracted domain-specific references to tasks in those documents, based on the structure of the document and the existence of a tabular definition of tasks and responsibilities, to reason about temporal dependencies between tasks. Furthermore, we are currently employing our approach to facilitate communication analysis by modeling the transactions between members of staff.

## 6 Discussion

The use of semantic-desktop environments promotes interoperability across organizations because most of the information interchange is based on e-mail and standard document formats rather than dedicated protocols. This design enables tracking and analysis of documents from outside sources and collaboration partners. In a way, the documents act as user interfaces to the tracking and analysis programs because they affect the actions of these systems.

In this work, we have addressed the analysis of standard documents. However, we believe that it is possible to augment documents with additional metadata to achieve *semantic documents* [Eriksson and Bång, 2006, Eriksson, 2007]. Such semantic document can contain ontologies with concepts that are linked to words, sentences, paragraphs, and other parts of the document. It is possible to add this information to standard document formats, such as PDF, to allow analysis programs to access metadata directly without extracting them from the document text. For example, by representing the content of decision tables in the

---

<sup>1</sup> to synchronize the use of resources over time during a mission

documents as ontology classes and instances, a semantic-desktop environment could compare documents directly by performing ontology matching. In other words, semantic documents have the potential of retaining semantic information available at the time of document preparation.

A long-term goal for domain-specific semantic-desktop approach is to make it available to a broad range of applications by lowering the effort to custom tailor the environment. In the area of knowledge acquisition, researchers have developed metatools for instantiating domain-specific knowledge-acquisition tools from high-level descriptions [Gennari et al., 2002]. A similar approach could potentially be used to create domain-specific extensions for semantic-desktop environments. For example, we believe that a meta-level tool could generate a domain-specific extension from a combination of domain ontologies and document templates. Naturally, there are many design alternatives for making domain-specific commitments in future generalized semantic-desktop environments and for developers to specify the domain-specific aspects.

Our evaluation of semantic desktops as a viable approach for supporting document-driven staff work has currently been conducted through technical implementation work, based on analyses from participating in and observing actual staff work. The results of our work indicates that semantic desktops can be used successfully to extract and reason about information critical to commanders and represented as parts of the contents or the structure of documents. In military staff exercises, we have identified issues related to the management of temporal and spatial information in documents that was a major cause of concern. Since effective sense making is crucial to a staff, and since that process implies primarily interpreting information jointly, means for organizing the desktop content according to semantic entities instead of the physical structure of documents would make valuable contributions to the work environment of commanders.

## **7 Conclusion**

Semantic desktop systems have the potential to enhance document-driven knowledge-management processes through more effective management of semantic entities in documents and communications. One of the main advantages of the semantic-desktop approach is that it supports the users in their daily activities without introducing traditional application systems that require separate streams of information handling. To maximize the benefit of semantic desktops, however, we believe that it is necessary to adapt these systems to the knowledge-management environment of the users and the tasks that the users are performing daily.

A remaining challenge for domain-specific semantic desktops is to find ways to customize the system to the documents and work patterns particular to the

application area. Specifically, it is important to streamline the adaptation of document analysis for new document types.

## Acknowledgments

This work was supported by the Swedish National Defence College.

## References

- [Baader et al., 2003] [Baader et al., 2003] Baader, F., Calvanese, D., McGuinness, D., Nardi, D., and Patel-Schneider, P., editors (2003). *The Description Logic Handbook*. Cambridge University Press.
- [Berners-Lee et al., 2001] [Berners-Lee et al., 2001] Berners-Lee, T., Hendler, J., and Lassila, O. (2001). The semantic web. *Scientific American*, 284(5):28–37.
- [Cheyer et al., 2006] [Cheyer et al., 2006] Cheyer, A., Park, J., and Giuli, R. (2006). IRIS: Integrate. relate. infer. share. In *Proceedings of the Semantic Desktop and Social Semantic Collaboration Workshop (SemDesk-2006)*.
- [Cunningham et al., 2002] [Cunningham et al., 2002] Cunningham, H., Maynard, D., Bontcheva, K., and Tablan, V. (2002). GATE: A framework and graphical development environment for robust NLP tools and applications. In *Proceedings of the 40th Anniversary Meeting of the Association for Computational Linguistics*.
- [Dong and Halevy, 2005] [Dong and Halevy, 2005] Dong, X. L. and Halevy, A. (2005). A platform for personal information management and integration. In *Proceedings of the Second Biennial Conference on Innovative Data Systems Research*.
- [Eriksson, 2007] [Eriksson, 2007] Eriksson, H. (2007). The semantic document approach to combining documents and ontologies. *International Journal of Human-Computer Studies*, 65(7):624–639.
- [Eriksson and Bång, 2006] [Eriksson and Bång, 2006] Eriksson, H. and Bång, M. (2006). Towards document repositories based on semantic documents. In *Proceedings of the Sixth Conference on Knowledge Management*, pages 313–320, Graz, Austria.
- [Gennari et al., 2002] [Gennari et al., 2002] Gennari, J. H., Musen, M. A., Ferguson, R. W., Grosso, W. E., Crubézy, M., Eriksson, H., Noy, N. F., and Tu, S. W. (2002). The evolution of Protégé: an environment for knowledge-based systems development. *International Journal of Human-Computer Studies*, 58:89–123.
- [Sauermaann et al., 2006] [Sauermaann et al., 2006] Sauermaann, L., Grimnes, G. A., Kiesel, M., Fluit, C., Maus, H., Heim, D., Nadeem, D., Horak, B., and Dengel, A. (2006). Semantic Desktop 2.0: The Gnows Experience. In Cruz, I., editor, *Proceedings of the International Semantic Web Conference (ISWC 2006)*, volume 4273 of *Lecture Notes in Computer Science*, pages 887–900. Springer Verlag.

# **Knowledge Building and Competence Development in eLearning 2.0 Systems**

**Malinka Ivanova**

(Technical University – Sofia, Bulgaria  
m\_ivanova@tu-sofia.bg)

**Abstract:** In the paper the new possibilities of eLearning 2.0 management systems for knowledge production, experience sharing and communication are presented. The Web 2.0 effects and mechanisms for knowledge capturing and construction are discussed. Reviews of seven new generation learning systems are done with aim one of them to be selected for knowledge building and competence development during the university education as well as after degree receiving. The analysis of eLearning 2.0 management systems is performed in context of the IEEE LTSA (Learning Technology Systems Architecture) component architecture.

**Keywords:** eLearning 2.0, LMS, LCMS, knowledge transfer, competence development, IEEE LTSA, analysis

**Categories:** H.0, H.5.3, H.5.4, J.0, J.4, M.4

## **1 Introduction**

At the present time, information and knowledge are increasingly produced, distributed and used collaboratively through the proposed possibilities of Web 2.0 technologies [Grant, 06], [Prensky, 06], [Kerres, 06], [Alexander, 06]. Knowledge management is generally understood as a means of having better control over the production and usage of explicit and implicit knowledge. The paradigm shift in the understanding of information and knowledge management is not just the result of a particular distribution or retrieval process, using and applying existing knowledge to new problems, but it is also the result of communication, collaboration and social interactions. The new view on knowledge management does not take knowledge and information as fixed, but emphasizes the ongoing growth and renewal of information and knowledge in a continual process of authoring, sharing and contribution.

Technology can play an important role in ensuring that learning is the result of a dialogue and production of new knowledge, experience and competences in new environments for audiences in and beyond the classroom, making learning design, courses content and learner activities more relevant. The integration of new emerging technologies, tools and systems into a tailored learning process is an important reason for achieving the quality in the education and society.

Current pedagogical, organizational and technological models for learning do not meet wholly the demands and possibilities for knowledge acquisition and competence development. Traditional LMSs – open source based and commercial ones are typically closed systems where knowledge cannot be received, transferred and

diffused outside. They do not allow the integration of formal and informal learning opportunities for individuals and groups.

The new approaches of eLearning 2.0 management systems suppose openness between learners and knowledge providers in the framework of the curriculum as well as beyond it - in self-organized groups, community of practices and social networks during the university education and after degree receiving.

The aim of this paper is to discuss the new possibilities of eLearning 2.0 management systems in order to select environment for knowledge building and competence development. The paper is organized as follows. In section 2 the Web 2.0 effects and mechanisms for knowledge capturing and sharing are presented and their impact on eLearning 2.0 is summarized. Section 3 contains the analysis of eLearning 2.0 management systems in the context of the IEEE LTSA component architecture and the review of seven new generation learning systems is done. The conclusion is placed in Section 4.

## 2 eLearning 2.0 and Knowledge Transfer

eLearning 2.0 is based on Web 2.0 technologies and emerging trends in eLearning and proposes different mechanisms for knowledge capturing and reusing [Downes, 06], [Rosen, 06]. Some arising effects explain the new way in production, sharing and transferring the information and knowledge through the collaborative framework and collective intelligence:

- *Data, information and knowledge on an epic scale* – This effect characterizes the methods for data, information and knowledge gathering and remixing - not only from search engines, but it is collected indirectly from users and aggregated as a side effect of the ordinary use of major web services and applications.
- *Network effect* - The Network effect is a term used to describe the increase in value to the existing users of a service in which there is some form of interaction with others, as more and more users start to use it.
- *Collective intelligence* – This effect reflects the knowledge embedded within societies or large groups of individuals. Collective intelligence can be explicit, in the form of knowledge gathered and recorded by many people and implicit intelligence that result from the data generated by the activities of many users over time.
- *Long Tail* – This effect leads to realization of significant profit out of selling small volumes of hard-to-find items to many customers, instead of only selling large volumes of a reduced number of popular items. The group of persons that buy the hard-to-find or "non-hit" items is the customer demographic called the Long Tail [Wikipedia, The Long Tail]. The Long Tail effect is related to the personalization in eLearning [Karrer, 08].
- *Snowflakes Effect* – Also, the importance of personalized eLearning is reflected through Snowflakes effect: all snowflakes in a snowstorm are unique, so each person has specific characteristics and interests [Duval, 07].
- *Openness* - The web proposes working with open standards, using open source software, making use of free data, reusing data and working for creating innovative solutions.



### 3 Analysis of eLearning 2.0 Systems

The new generation LMSs is built as a reflection on Web 2.0 characteristics and effects such as networked communication, collaborative learning, integration of social software applications, and further for developing the new competencies surrounding knowledge acquisition and information sharing.

#### 3.1 Used Methodology

The analysis of eLearning 2.0 Systems is performed with the goal to select a solution for knowledge production and management. The methodology comprises: (1) investigation via Internet search engines and using keywords “LMS, LCMS” and “Web 2.0”, (2) forming a feature list with several criteria for the description of the functional features, (3) experimental practices with the environments, (4) comparison between eLearning 2.0 system and LTSA and (5) making the decision.

#### 3.2 Analysis

The seven eLearning 2.0 systems are identified: EctoLearning, Edu 2.0, eLearning Community 2.0, LearnHub, LectureShare, Nfomedia and Tutorom. They are examined according to the created criteria list which is focused on their main functional features for knowledge capturing and sharing and competence development. These features are summarized in Table 1.

*EctoLearning* is a networked Personal Learning Environment where the learning content and knowledge can be user-created, user-rated, shared and open. Ecto hosts libraries of knowledge content that can be explored by class participants and imported, exchanged, rated, modified or just shared. [EctoLearning, 08].

*Edu 2.0* is a Learning Management System (LMS) with features for teachers, students and parents. The functionality of Edu 2.0 includes: private or public class registration, personal portfolio and space creation; group, community and network collaboration, assessment, tracking and monitoring, communications [Edu 2.0, 08].

*eLearningCommunity 2.0* is a social site for knowledge seekers to enrich their knowledge through online learning, sharing and socializing. It proposes tools and services for (1) knowledge providers: organizing a virtual classroom, conversion of knowledge into variety of digital formats, a knowledge repository area, communication; (2) knowledge seekers: access the knowledge repository on a demand, communicate with knowledge-provider through various interaction tools provided in the learning management system [eLearning Community 2.0, 08].

*LearnHub* is a network of communities. For teachers LearnHub proposes tools for online teaching. For students: LearnHub gives free access to courses with specific subjects. There are many communities which offer information, created by expert teachers, and other students. The line between teacher and student is blurred, because a student in one subject can be a teacher in another [LearnHub, 08].

*LectureShare* is a LMS that connects students and instructors by allowing instructors to effortlessly post course material and allowing students to get course updates via text messages, emails or RSS. Students: stay organized with course materials and announcements for all chosen classes gathered in a single location, beyond text-streaming audio and video content along with text and files [LectureShare, 08].

Criteria		EctoLearning Course-Pages	Edu2.0 Schools-Class- lessons	eLearning Community 2.0 Classroom- Course	LearnHub Course-Lesson	LectureShare Course-Lectures	Nfomedia Course-Unit	Tutorom Courses- Lessons
Information and knowledge capturing and sharing Tools and Services	Course Weblog		●				●	●
	Course Wiki		●				Wikis tyle	●
	Book-marking	●						
	RSS Feeds	●	●			●		
	Link Sharing	●	●	●	●	●		●
	Picture Sharing	●	●	●	●			●
	AV/ Podcast	●	●	●	●	●		●
Com-muni-cation	Synchr.		●	●		●	●	●
	Asynchr.	●	●	●	●	●	●	●
Social Networking	Social Network	Entire social groups	Schools, Classes, Groups	Communi-ties	Com-muni-ties	Communi-ties	Add conta cts	Communi-ties, Groups
	Communi-ty file sharing	●	●		●	●	●	
Produc-tivity Tools	Search	●	●	●	●	●	●	●
	Event Planning	●	●	●				
ePortfolio Creation Tool		●	●					
Personalization Tools			●				●	
Assessment			●	●			●	
New educational widgets creation	●	●						
	Import		Integrate					

Table 1: eLearning 2.0 System Tools and Services

Nfomedia is a system for higher education professors to augment their traditional classroom courses, and it's typically used to supplement the traditional classroom course to enable blended learning. Nfomedia is also an online hub for professors and students providing various ways to stay connected [Nfomedia, 08].

Tutorom (Eduslide) allows knowledge providers to create educational content and deliver it online. The system offers different ways of presenting information, as well as testing modules, wikis, chat, blogs, and slideshows. The templates for developing the complex learning web sites facilitate providers of knowledge [Eduslide, 08].

### 3.3 eLearning 2.0 System Component Architecture

The analysis of eLearning 2.0 systems is performed in the context of IEEE LTSA architecture [IEEE LTSA, 01]. The existing model of IEEE LTSA is brought up-to-date with the main aim to discover high-level frameworks for understanding certain kinds of system's components, and their interactions. The repository with Learner Records in IEEE LTSA is replaced from Learner ePortfolio that contains the learner's knowledge production according to performed learning activities. Also, Learning Resources repository is replaced with Knowledge repository, where knowledge is gathered from different web sources using several services. The process Coach is replaced by Knowledge provider who can be educator, other learner, and expert. The model is presented in Figure 1 and its main components are explained in Table 2.

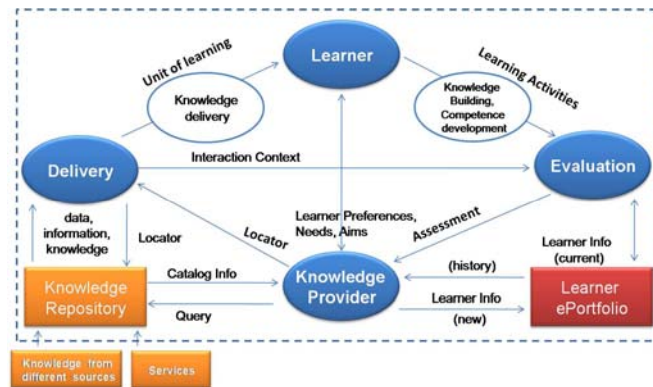

Figure 1: Component Architecture of eLearning 2.0 System

Processes and Stores	Standard LMSs	eLearning 2.0 Systems
<p><b>Learner</b> A conceptual process that represents an abstraction of a human learner: a single learner, a group of learners</p>	<p>The learners learn in a closed environment with access to other systems and virtual laboratories in the time of the course duration.</p> <ul style="list-style-type: none"> <li>- (Input/Output) The preferences, needs, aims are negotiated with the educator.</li> <li>- (Input) The learner receives course content.</li> <li>- (Output) The learner's activities are monitored.</li> </ul>	<p>The learners use an open environment with communities of practices, self-organized groups and social networks during the course and after this.</p> <ul style="list-style-type: none"> <li>- (Input/Output) The preferences, needs, aims are negotiated with the knowledge providers or they are self-defined by learners.</li> <li>- (Input) The learner receives not only Units of Learning, but shared knowledge, experience, ideas.</li> <li>- (Output) The results of learner's activities are knowledge products saved in ePortfolio.</li> </ul>
<p><b>Evaluation</b> A conceptual process that produces measurement(s) of the learner</p>	<p>The evaluation is done primarily by educator.</p> <ul style="list-style-type: none"> <li>- (Input) The learner's observable behavior.</li> <li>- (Output) Assessment information is sent to the educator.</li> <li>- (Input/Output) Learner information is stored in the Learner Records.</li> </ul>	<p>The knowledge provider can participate in the evaluation process as well as other learners.</p> <ul style="list-style-type: none"> <li>- (Input) The learner's constructed knowledge.</li> <li>- (Output) Assessment information is accessible by all evaluators.</li> <li>- (Input/Output) The products of learner's activities are retrieved and stored during evaluation process in the Learner ePortfolio.</li> </ul>

Processes and Stores	Standard LMSs	eLearning 2.0 Systems
<p><b>Knowledge Provider</b> A conceptual process that incorporate information from several sources, such as the learner, evaluation process, learner portfolio, and knowledge repository and use this information to search and select appropriate knowledge content.</p>	<p>The knowledge provider is primarily educator.</p> <ul style="list-style-type: none"> <li>- (Input/Output) The preferences, needs and aims are defined.</li> <li>- (Input) The current assessment information from the evaluation process</li> <li>- (Input) Learner information from the learner records.</li> <li>- (Output) Queries may be sent to the learning resources to search for resource.</li> <li>- (Input) The learning resources return catalogue information.</li> <li>- (Output) Locators are sent to the delivery process.</li> </ul>	<p>A Knowledge provider can be educator, learner, expert and so on, who is registered and participates in the social environment.</p> <ul style="list-style-type: none"> <li>- (Input/Output) The preferences, needs and aims are defining and changing continuously</li> <li>- (Input) The current assessment information from the evaluation process</li> <li>- (Input) Learner's products from the ePortfolio.</li> <li>- (Output) Queries may be sent to the shared knowledge repository to search for (appropriate) knowledge.</li> <li>- (Input) The knowledge repository return catalogue information, e.g., a list of locators that match the search query.</li> <li>- (Output) Locators (information, knowledge) are sent to the delivery process.</li> </ul>
<p><b>Delivery</b> A conceptual process that transforms knowledge obtained via knowledge repository and deliver it to the learners.</p>	<ul style="list-style-type: none"> <li>- (Input) May receive locators from the educator.</li> <li>- (Output) May use locators to retrieve resources.</li> <li>- (Input) May receive retrieved resources and may transform them in multimedia.</li> <li>- (Output) May send multimedia to the learners.</li> </ul>	<ul style="list-style-type: none"> <li>- (Input) May receive locators from the knowledge provider and/or learners.</li> <li>- (Output) May use locators to retrieve knowledge from different knowledge sources.</li> <li>- (Input) May receive retrieved knowledge and may transform it into a Unit of Learning for the learner.</li> <li>- (Output) May send Unit of Learning with integrated knowledge to the learners.</li> </ul>
<p><b>Learner ePortfolio</b> It stores learner's performance information.</p>	<p>Learner record stores information for learner.</p> <ul style="list-style-type: none"> <li>- (Input/Output) The evaluation process store/retrieve learner's information</li> <li>- (Input) Learner information is sent by educator.</li> <li>- (Output) - Learner information is retrieved by educator.</li> </ul>	<p>Learner Portfolio is a storage contains the products of the learner's activities.</p> <ul style="list-style-type: none"> <li>- (Input/Output) After the evaluation process the learner's products are stored/retrieved.</li> <li>- (Input/Output) The knowledge provider process store/retrieve the learner's information.</li> </ul>
<p><b>Knowledge repository</b> It collects, stores, retrieves knowledge</p>	<p>The Learning Resources Repository contains the resources uploaded by educators and/or learners.</p> <ul style="list-style-type: none"> <li>- (Input) May be searched by queries.</li> <li>- (Output) The matching information is returned as catalogue info.</li> <li>- (Input/Output) The locators are used by the delivery process to retrieve knowledge.</li> </ul>	<p>Knowledge Repository includes knowledge derived by different sources using several services and tools such as: RSS syndication, blog, wiki, podcasts.</p>

Table 2: Description of eLearning 2.0 System Components

### 3.4 Analysis Results

This overview and analysis shows that the eLearning 2.0 systems possess the potential for knowledge transfer and competence development through their possibilities for: flexible management of collaborative strategies; sharing knowledge and best practices via open networks; Personal Learning Environment building and self-organized learning starting; RSS syndication, knowledge sharing, social networks contributing, assessing, accessing, and refining information and knowledge; innovations through using the functionality for new tools and widgets integration and development.

This analysis leads to the selection of an eLearning 2.0 system for knowledge and competence building in the higher education. Edu 2.0, eLearning Community 2.0 and Nfomedia are outlined as good solutions for this purpose. Edu 2.0 is chosen for further analysis, research and deployment, because of the rich functional features.

In Figure 2 the opportunity for multiple, simultaneous knowledge transfer for the same learner via integration of multiple learning activities, preferences, and different knowledge sources is presented. The learners can work in parallel sessions with an eLearning 2.0 system, Start page and Social Networks to receive effective performance support in their successful activities completeness.

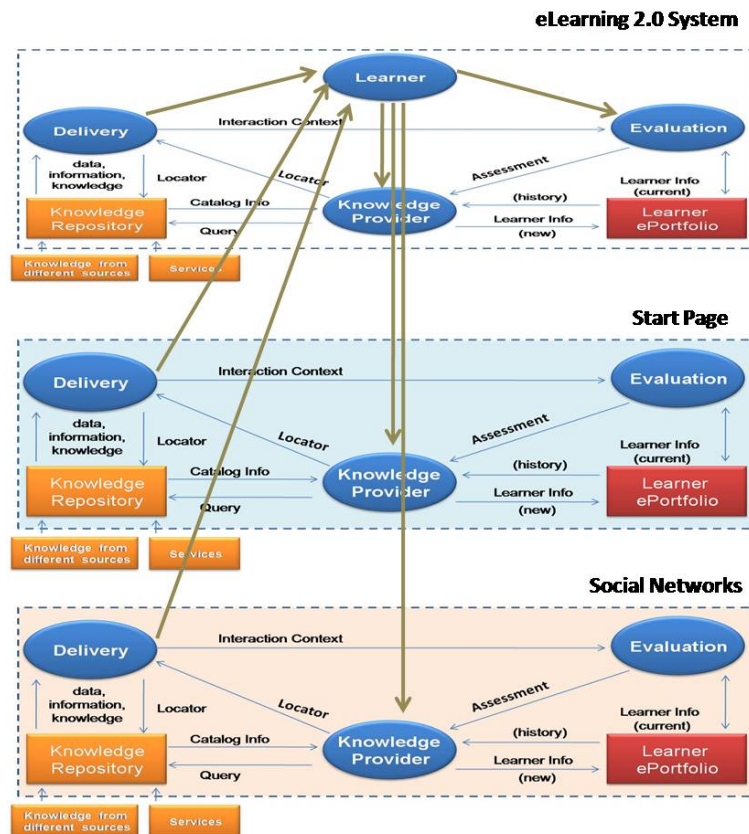

Figure 2: Multiple, Simultaneous Knowledge Capturing

## 4 Conclusion

In the paper the functions of seven eLearning 2.0 systems are examined and analyzed in the context of used Web 2.0 technologies, emergent eLearning directions and IEEE LTSA. Analysis shows that the eLearning 2.0 systems allow educators and learners actively exchange ideas, information and knowledge, work together on projects, from anywhere, using multiple communication modes. These environments stimulate the active participation and individual production of knowledge, support the performance of formal and informal web-based learning activities, form a bottom-up and less control-oriented learning culture, give the greater leverage of collective intelligence to create learning experiences, support the dynamics and openness of a learning process. Edu 2.0 is chosen for further research, learner's knowledge transfer and competence development. This eLearning 2.0 system can be used in parallel with start pages and social networks to enhance a learning process, according to proposed model.

## References

- [Alexander, 06] Alexander, B.: Web 2.0: A NewWave of Innovation for Teaching and Learning? Educause Review, 41(2) March/April, 2006  
<http://www.educause.edu/ir/library/pdf/erm0621.pdf>
- [Downes, 06] Downes, S.: E-learning 2.0, eLearn Magazine, 2006 <http://www.elearnmag.com>
- [Duval, 07] Duval, E.: Snowflakes Effect: Open learning without boundaries, 2007xxx  
<http://ariadne.cs.kuleuven.be/mediawiki2/index.php/SnowflakeEffect>
- [EctoLearning, 08] <http://www.ectolearning.com/>, [Edu 2.0, 08] <http://www.edu20.org/>
- [Eduslide, 08] <http://www.eduslide.net/>, [eLearning Community 2.0, 08] <http://www.elearningcommunity.com/>
- [Grant, 06] Grant, L.: Using Wikis in Schools: A Case Study, 2006  
[http://www.futurelab.org.uk/resources/documents/discussion\\_papers/Wikis\\_in\\_Schools.pdf](http://www.futurelab.org.uk/resources/documents/discussion_papers/Wikis_in_Schools.pdf)
- [IEEE LTSA , 01] IEEE P1484.1/D8, 2001-04-06 Draft Standard for Learning Technology — Learning Technology Systems Architecture (LTSA), 2001  
[http://ltsc.ieee.org/wg1/files/IEEE\\_1484\\_01\\_D08\\_LTSA.pdf](http://ltsc.ieee.org/wg1/files/IEEE_1484_01_D08_LTSA.pdf)
- [Karrer, 08] Corporate Learning Long Tail and Attention Crisis, 2008  
<http://elearningtech.blogspot.com/2008/02/corporate-learning-long-tail-and.html>
- [Kerres, 06] Kerres, M.: Web 2.0 and its implication for eLearning, MicroLearning conference, Innsbruck, Austria, 2006
- [LearnHub, 08] <http://learnhub.com/>, [LectureShare, 08] <http://www.lectureshare.com/>
- [Nfomedia, 08] <http://www.nfomedia.com/>
- [Prensky, 06] Prensky, M.: Delivering 21st Century tools, learning and skills education, Australian National Seminar, March 2006 <http://www.educationau.edu.au/jahia/Jahia/pid/202>
- [Rosen, 06] Rosen, A.: Technology Trends: e-Learning 2.0, The eLearning Guild, eMagazine, 2006 <http://www.readygo.com/e-learning-2.0.pdf>
- [Wikipedia, The Long Tail] The Long Tail [http://en.wikipedia.org/wiki/The\\_Long\\_Tail](http://en.wikipedia.org/wiki/The_Long_Tail)

## Improving Recommendations by Using Personality Traits in User Profiles

Maria Augusta S. N. Nunes<sup>1</sup> and Stefano A. Cerri

(LIRMM- Université Montpellier 2 & CNRS  
161 rue ADA - 34392 - Montpellier - France  
nunes@lirmm.fr, cerri@lirmm.fr)

Nathalie Blanc

(Université Montpellier 3 - LMC  
Route de Mende 34199 - Montpellier - France  
nathalie.blanc@univ-montp3.fr)

**Abstract:** By storing Personality Traits in User Profiles we enable Recommender Systems to deduce more interesting recommendations for users acting pro-actively in order to offer them products/services as a consequence of a prediction of their future needs and behavior. This paper is proposed to improve the robustness of recommendations by using psychological aspects such as Personality Traits. This paper is a part of a PhD ongoing work.

**Key Words:** User Psychological Profile, Identity, Reputation, Personality Traits, Recommendation

**Category:** H.1.2, H.3.4, I.2

### 1 Introduction

Considering claims of the International Community of Knowledge Management, "I-Knows" stress the searching for researchers that include at least one of the following claims: the needs of individual people's knowledge for flexibility with the needs of communities for interconnectivity and the needs of organizations for standardization. They believe that "knowledge services have the potential to support and merge two roles within organizations and communities: on the one hand this concerns people's knowledge which needs support for executing their current task efficiently (also by using the help of community members) and to advance their competencies over time; on the other hand the knowledge engineer needs support for the identification, modeling and standardization of community knowledge patterns and organizational knowledge structures".

We propose to help to fill this gap by proposing relevant knowledge services which will be helpful mainly to develop people's knowledge (Profiles and Reputations) about themselves and their community. Research about psychological characteristics of people's knowledge and community is needed to inform what

---

<sup>1</sup> PhD partly supported by CAPES and URI University in Brazil

type of service should be given to ensure its usefulness. As a consequence of the use of psychological characteristics, people's knowledge will be able to dynamically integrate contextualized knowledge services such as recommendation of knowledge artifacts, community awareness and collaboration support into their work environment.

The World Wide Web is an enormous source of products and services available for people. There is a huge effort done by scientists towards the creation of effective strategies to personalize those products/services for each people interested to use them. The personalization may be provided by Recommender Systems able to match people's preferences and some specific product or service.

Scientists from research areas such as Psychology [Thagard 2006], Neurology [Damasio 1994] and Affective Computing [Picard 1997] [Trappl et al 2003] agree that human reasoning and decision-making are hardly affected by psychological aspects. Thus, to maintain the same level of personalized service provided by humans, computers also should "reason" taking into account user psychological aspects. Nevertheless, unfortunately, the psychological aspects are neglected by most of the models of User Profiles. By consequence, the existing Recommender Systems do not use the psychological aspects during their decision-making. We intend to improve Recommender Systems by storing psychological traits in User Profiles, in order to be able to deduce more interesting recommendations for users. In this approach, the system acts proactively towards the user needs, offering products/services in prediction to their future needs.

This paper is presented as follow: Firstly, we describe studies done in Psychology describing Personality, Traits and Tests in order to formalize how to define, to model and to extract Psychological aspects of users in order to extract their identities and to build their Profiles. Followed by the description of how the User Reputation is formalized and how Recommender Systems is described. Finally we present our experiment followed by results and conclusions.

## 2 Psychological Aspects

In this paper we define User Psychological Aspects by using the theory of Personality. While Personality have not yet a common definition, psychologists like Burger [Burger 2000] defines personality a "consistent behavior patterns and intrapersonal processes originating within the individual".

Personality is more than just superficial and physical appearances, it is relatively stable and predictable, however it is not rigid and unchanging (normally it remains stable over-45 years period beginning in young adulthood). Personality may be defined by many different approaches. We chose Traits approach because it can differ people psychologically by using a conceptualization and measurable traits, called Personality Traits. Indeed, Personality Traits are a cluster of human features able to be modeled and implemented in computers.



Personality Traits were first defined by Allport [Allport and Allport 1921]. Allport creates 17.953 traits (common traits and individual traits) to describe the personality of an individual. Because most of the individual differences are insignificant in people's daily interactions, in order to limit the definitions of traits in an exponential way researchers assume that all men are "like some other men". Considering this, researchers reduced more 99% of trait items because they conclude only five factor was replicable. As a result, the "Big Five" Model [John and Srivastava 1999] was created. Even if Big Five factors represent a broad level of personality structure, they not guarantee exhausting all significant personality dimensions. Facets are used by psychologists in order to enrich Big Five dimensions with more fine-grained characteristics.

In order to extract human traits (as Big Five factors and their respective facets) psychologists usually use computer based questionnaires which are called Personality Tests. We propose to use NEO-IPIP Personality Test. It allow to assess 5 factors of Big Five including also more 6 facets for each dimension (30 facets in total) using then a fine-grained descriptions of people's personality traits and a consequent bigger precision in those traits representation.

NEO-IPIP Inventory [Johnson 2000b] was created when Johnson chose from among the various personality inventories of a public domain scales called IPIP (The International Personality Item Pool [Goldberg 1999]) his 300 items proxy for the revised NEO Personality Inventory (NEO-PI-R) [Costa and McCrae 1992]. Johnson chooses to create a NEO-IPIP because it is a free of charge version of NEO-PI-R which is one of the most robust, used and well-validated commercial inventory in the world [Johnson 2000a].

Personality Test, is a computer narrative instrument able to measure person's individual differences. Those individual differences are named "Personality Traits" which generally reveal cues about person's Identity and person's Public Reputation and might be used in recommendation of knowledge artifacts and community awareness.

### 3 Identity, User Profile and Reputation

According to researchers of Personality theory, the Identity development receive an important influence of person's personality. Boyd [Boyd 2002] describes two different aspects of the individual Identity: the internalized notion of the self (Internal Identity) and the projected version of ones internalized self (Social Identity). Considering Identity as an important channel where people personality appears, their Personality Traits (Individual and/or Social) will give cues about their future behaviors and needs in a community.

In Computer Science, the technical and persistent way to formalize Identity in a Virtual Community (or Social Network) is using User Profile and User Reputation.

Donath [Donath 1999] affirms that ones own Identity (Internal) and ones reputation (Social) are fundamental to the formation of a community. In a Virtual Community the Virtual Identity of user is defined by him/herself similarly he/she does in the real world. The Identity is stored in User Profiles, like in e-commerce and e-communities areas for example.

User Profiles are approximate concepts, they reflect the interest of users toward several subjects at one particular moment. Each term a User Profile expresses is, in a certain degree, features of a particular user including all information directly requested from him/her and implicitly learned from web activity [Poo et al 2003]. Physically, the User Profile can be see as a database where the user information, interests and preferences are stored.

In order to define user Identity, together with User Profiles (Internal Identity), User Reputations (Social Identity) is also very relevant and, consequently, should also be presented.

Reputation can be defined as the social feedback opinion given about someone personality. The Reputation may agrees or not with the description done in the User Profile. Josang et al in [Josang et al 2007] describes Reputation as "the information generally said or believed about a person's or thing's character or standing".

In this work we define Reputation as an extension of a User Profile. It uses the same type of information stored in the User Profile but instead of the information to be filled by user it is filled by a friend. In this work the Identity are determined by the Personality Traits of user stored by him/herself physically in the User Profile and by his/her friends physically in User Reputation.

User Profiles and/or User Reputations are very important in order to define the user's Identity. That means, User Profile and Reputation can provide the prediction of user behavior and needs in a community while Reputation also allows the creation of relation of trustworthiness among community members. The user's Identity is very useful during social interaction inside a Community.

Unfortunately, Psychological aspects like Personality Traits have not yet been implemented in a current User Profiles/Reputations. That happens mainly because human psychological aspects are really hard to extract intentionally from user. Even if psychological aspects are difficult to extract, their relevance is quite significant in the recommendations<sup>2</sup> to be ignored by Recommender Systems, as we see next.

## 4 Recommendations

Recommendation is a deliberative social process done by ordinary people when they want to describe their degree of appreciation about someone or something.

---

<sup>2</sup> used a posteriori for supporting the user decision making process in a context of Knowledge services.

In computers, Recommender Systems begin to appear in 90's, they are applications that provide personalized advice for users about products or services they might be interested in [Resnick and Varian 1997]. They are mainly used to recommend products or services.

In ordinary life, normally people trust in recommendations done by others. Those recommendations appear to them as word of mouth reputation, recommendation letters, movie and book reviews printed in newspapers and magazines. In digital life, Recommender Systems start to be used as a trustful information of people opinions (Reputation) about other people, services and products used by them.

Recommender System is a rich problem research area. It has abundant practical applications also defined as systems which promote recommendation of people (normally seen as service provider) as well promote recommendation of products/services. In 2005, Terveen [Terveen and McDonald 2005] redefined those specific Recommender Systems, called Social Matching Systems.

Unfortunately, Recommender Systems do not use psychological aspects in its recommendations. However, psychological aspects are a powerful features that improve significantly the recommendations.

In 2005 Gonzalez [Gonzalez et al 2007] proposed a first model based on psychological aspects, he uses Emotional Intelligence to improve on-line course recommendations. Next, in this work we propose an illustrative scenario in order to prove, actually, that the use of Personality Traits in User Profile/Reputation might definitively improve recommendations done by a Recommender System.

## 5 Experimentation

This paper addresses an experimentation in order to prove that Recommender Systems (or Social Matching Systems) can be more effective if they use Psychological Traits of people than just conventional ones (demographic information and competence, for instance) in order to recommend more adequate products, services or people.

This experimentation contemplates the Recommender System showing its ability to recommend people, in this case, considerate as a product to be delivered according to a product view<sup>3</sup>.

---

<sup>3</sup> The Recommender System generate a person as a product because, in this case, a person is considered as a packet closed, a person's name, for instance. In this case, the person is not considered as a service provider, as normally s/he is. The product view means, a person receives a recommendation of someone as a name to be took into account as a support in his/her decision making process. In a service view, people receive a name to be used as a service provider, who will execute some service in posteriori. In a product view, the Recommender System gives a passive answer, different from a service view where the answer is going to generate a dynamic interaction in order to generate a service.

Here the Recommender System is going to generate a product of its internal processing called recommendation. The generated product, in this case, is a person's name. This name could be used as knowledge support during the decision making process for a person and his community in a Knowledge management scenario.

### 5.1 Scenario

An illustrative scenario was presented by the "Elections for President in France" carried through april 2007. In this case a Recommender System was used to give a private recommendation considering a better choice of a president's candidate for a person to vote. This experimentation started to be applied in december 2006 and finished in july 2007.

This experimentation focus on User Psychological Reputation (User Psychological Profile according friends view) based on people's feedback of candidates on a specific case of the French presidential.

### 5.2 Method

In order to create a User Psychological Profile/Reputation we used the NEO-IPIP Inventory<sup>4</sup> based on 300 items.

About 100 people were invited to participate.

Each people who participated the experimentation was instructed to answer the NEO-IPIP(900 questions): thus, 300 (NEO-IPIP) for "The Ideal President", 300 for "Ségolène Royal" and 300 for "Nicolas Sarkozy". They are:

1. "The Ideal President" questionnaires. Questionnaires's answers reflects how each person thinks an Ideal President should be;
2. "Ségolène Royal" (one of the president's candidate) questionnaires. Questionnaires's answers reflects how each person feels and thinks about "Ségolène Royal"'s psychological traits.
3. "Nicolas Sarkozy" (one of the president's candidate). Questionnaires's answers reflects how each person feels and thinks about "Nicolas Sarkozy"'s psychological traits.

Through answers we were able to model psychological aspects of two French presidential candidates, Ségolène Royal, Nicolas Sarkozy and a imaginary "Ideal President". The recommendation done was based on those psychological aspects (reputation) of President's candidates and an imaginary personage who was his/her dreamed "Ideal President".

---

<sup>4</sup> The tool used to extract Reputations is partly described in [Nunes et al 2007] and can be found at <http://www.lirmm.fr/~nunes/big0.1/> .

In order to assess the validity of the questionnaire and the precision of our Recommender System, each person who answered seriously and completely the three questionnaires should confirm that the President's candidate recommended for him/her actually was the President who s/he, actually, VOTED (that's means, the candidate nearer psychologically of his/her own psychological definition of an imaginary "Ideal President").

Results and conclusions of the experimentation are presented next.

### 5.3 Results

10% of People answered the complete Personality Traits inventory (NEO-IPIP) in order to get the recommendation of *a better candidate to vote in a French Presidential*.

We did two different types of recommendations. The first one was based on 30 facets and then in 5 factors of Big Five, followed by the second one which was based only on 5 factors of big five.

Results of the recommendations were much more satisfying and representative than what we expected. The first recommendation was more fine-grained than the second one. The results are:

- If we consider the fine-grained answers, that means Personality Traits measurable by 30 facets, the recommendation was 100% correct. That means, 100% of cases recommended by the Recommender System was compatible with the *presidential candidate* that the user actually *VOTED* during the Election for President in France;
- If we consider the coarse-grained answers, that means Personality Traits measurable by 5 Big Five factors, the recommendation was 80% well correct. That means, 80% of cases recommended by the Recommender System was compatible with the *presidential candidate* that the user actually *VOTED*. However, 20% of cases recommended by the Recommender System was INCOMPATIBLE with the *presidential candidate* that the user actually *VOTED*.

Even if is difficult and tiring answer a fine-grained questionnaire (30 facets) the final result of a recommendation is 25 % better than if we use a coarse-grained questionnaire.

This experiment started to be applied in december 2006. Because we have a non massive participation (only 10% of people asked to answer the questionarie effectively did it), the recommendation have been generated in july 2007, that means, after the French presidential (april 2007).

Considering this, the recommendation were not useful in order to influence the people's action (their vote). However, the recommendation have been very

useful in order to prove that the recommendation generated was actually very relevant because *people's effective vote* was 100% compatible with the recommendation. That means, if people had received the recommendation before the votation, at least, they would be influenced positively. Otherwise, the recommendation might be used as an instrument for the knowledge management service in order to predict the user behaviors and/or needs using it as those relevant information to be used during the decision making process.

## 6 Conclusions

This work contributes to state of the art by using Personality Traits to improve the recommendations in Recommender Systems and consequently for providing this recommendation as a support in a decision making process for the knowledge management community. We chose the Traits approach because it is the way that psychologists differentiate people from one another, conceptualizing and measuring their characteristics by using Personality Traits.

Results of this experimentation proved that user Personality Traits stored in User Profile and processed by Recommender Systems can provide, when using a fine-grained questionnaire, actually, optimal recommendations. In the context of our experimentation the recommendation generated was done in order to select some *compatible candidate to vote in a French Presidential*. However, the experimentation presented here is meant to be significant for a much wider spectrum of cases where the use of Personality Traits may be of importance to Recommender Systems. Those recommendations could be used in knowledge services as a support for helping, clarifying and guiding human/machine decision making processes, for instance.

**Research follow up Future Work:** Even if the fine-grained questionnaire gave optimal recommendation (100% of compatibility), it was very hard to find people with time available to answer NEO-IPIP Personality Traits questionnaire (900 items on that experimentation). Many times in real circumstances researchers have no choice other than to use a extremely brief instrument (or they use no instrument at all). Because of that, we decided to develop a second experimentation using a coarse-grained questionnaire to verify if we will get better results (more than 80% extracted from the first experimentation). The second experimentation is being applied in order to recommend an efficient work group based on Personality Traits of students from a programming course at "Instituto Superior Técnico" in Lisbon. The results from these experiments are the subject of ongoing reports.

## References

- [Allport and Allport 1921] Floyd H. Allport and Gordon W. Allport. Personality traits: Their classification and measurement. *Journal of Abnormal and Social Psy-*

- chology*, (16):6–40, 1921.
- [Boyd 2002] Danah Boyd. Faceted id/entity: Managing representation in a digital world. Master's thesis, Cambridge, MA, August 2002.
- [Burger 2000] Jerry M. Burger. *Personality*. Wadsworth, fifth edition, 2000.
- [Costa and McCrae 1992] P. T. Costa and R. R. McCrae. Revised neo personality inventory (neo-pi-r) and neo five-factor inventory (neo-ffi): Professional manual., 1992.
- [Damasio 1994] Antonio R. Damasio. *Descartes' Error: Emotion, Reason, and the Human Brain*.
- [Donath 1999] Judith S. Donath. Identity and Deception in the Virtual Community. In Marc A. Smith and Peter Kollock, editors, *Communities in Cyberspace*, chapter 2, pages 29–59. Routledge, London, first edition, 1999.
- [Goldberg 1999] L. R. Goldberg. A broad-bandwidth, public-domain, personality inventory measuring the lower-level facets of several five-factor models. *Personality Psychology in Europe*, 7:7–28, 1999.
- [Gonzalez et al 2007] Gustavo Gonzalez, Josep Lluís de la Rosa, and Miquel Montaner. Embedding Emotional Context in Recommender Systems. In *The 20th International Florida Artificial Intelligence Research Society Conference-FLAIRS*, Key West, Florida, May 2007.
- [John and Srivastava 1999] O. P. John and S. Srivastava. The big five trait taxonomy: History, measurement, and theoretical perspectives. In Lawrence A. Pervin and Oliver P. John, editors, *Handbook of Personality: Theory and Research*, pages 102–138. The Guilford Press, New York, second edition, 1999.
- [Johnson 2000a] John A. Johnson. Predicting observers ratings of the big five from the cpi, hpi, and neo-pi-r: A comparative validity study. *European Journal of Personality*, 14:1–19, 2000.
- [Johnson 2000b] John A. Johnson Web-based personality assessment. In *71st Annual Meeting of the Eastern Psychological Association*, Baltimore, USA, 2000.
- [Josang et al 2007] Audun Jøsang, Roslan Ismail, and Colin Boyd. A survey of trust and reputation systems for online service provision. *Decision Support Systems*, 43(2):618–644, 2007.
- [Nunes et al 2007] Maria Augusta S. N. Nunes, Stefano A. Cerri, and Nathalie Blanc. Psychological identity x psychological reputation: How to recommend compatible peers in a work team. In *Workshop on Social eLearning : Mobile Ubiquitous Learning and Conversational Agents. At TIGERA2007- The International Conference on Computing x e-Systems*, Hammamet, Tunisie, 2007. Tigera.
- [Picard 1997] Rosalind W. Picard. *Affective computing*. MIT Press, Cambridge, MA, USA, 1997.
- [Poo et al 2003] Danny Poo, Brian Chng, and Jie-Mein Goh. A hybrid approach for user profiling. In *HICSS '03: Proceedings of the 36th Annual Hawaii International Conference on System Sciences (HICSS'03) - Track 4*, page 103.2, Washington, DC, USA, 2003. IEEE Computer Society.
- [Resnick and Varian 1997] P. Resnick and H. R. Varian. Recommender systems. *Communications of the ACM*, 40(3):56–58, 1997.
- [Thagard 2006] Paul Thagard. *Hot Thought: Mechanisms and Applications of Emotional Cognition*. A Bradford Book- MIT Press, Cambridge, MA, USA, 2006.
- [Terveen and McDonald 2005] Loren Terveen and David W. McDonald. Social matching: A framework and research agenda. *ACM Trans. Comput.-Hum. Interact.*, 12(3):401–434, 2005.
- [Trappl et al 2003] Robert Trappl, Sabine Payr, and Paolo Petta, editors. *Emotions in Humans and Artifacts*. MIT Press, Cambridge, MA, USA, 2003.

# **Applying Adaptive Collaborative Management for Social Learning: A Case Study of Community Forestry in Nepal**

**Chiranjewee Khadka**

(University of Natural Resources and Applied Life Sciences, Vienna, Austria  
chiranjewee.khadka@boku.ac.at)

**Harald Vacik**

(University of Natural Resources and Applied Life Sciences, Vienna, Austria  
harald.vacik@boku.ac.at)

**Abstract:** This contribution promotes the application of an adaptive collaborative management (ACM) approach for social learning in the context of Nepal's community forestry program. We highlight the principles of the ACM process, the problems, potentials and limitations of the approach especially to demonstrate social and collaborative learning for sustainable community forest management. Researchers and local facilitators were involved in a deliberative planning process and community forest users groups developed a common understanding of how to apply the ACM approach. In a joint learning process the users tested assumptions built upon their experiences and knowledge which allowed them to achieve the goals of the local community in a sustainable manner. Evidence of the combined application of the ACM process and social learning are presented from six case studies on community forestry in Nepal using a broader range of the knowledge management activities. Community forest management provides a participatory environment to achieve conservation and poverty reduction. In particular, the current status, challenges, and opportunities for future improvement as seen from the perspective of social learning are highlighted. Conclusions and policy suggestions are made as contribution for the development of a common understanding in which an ACM approach can be practiced to transform a knowledge management organization towards a learning environment.

**Keywords:** Nepal, Community Forestry, Adaptive Collaborative Management, Social Learning  
**Categories:** I.2.6, F.4.3, G.2.2

## **1 Introduction**

In this paper, we use the terms 'Adaptive Collaborative Management' (ACM) and 'adaptive co-management' to describe a management process that merges the principles of adaptive management with collaborative management, as well as the principles of social learning and participatory approaches [Fisher *et al.* 07]. We want to demonstrate that the opportunities of ACM and its application can support social learning in institutions and organisations in Nepal. The paper highlights the experiences and lessons of Participatory Action Research (PAR) project of the BOKU University in collaboration with the Nepal Ministry of Forests and Soil Conservation and national NGOs with funding from Austrian Academy of Science (KEF), Austria. The project is focusing on the development of Criteria and Indicators for sustainable Community forest management project, Nepal.



We want to indicate in this contribution the importance of involving diverse stakeholders for planning, reflection, and negotiation in order to contribute for a better management of community forests involving the complex environmental, socio-economic and political circumstances and people with differing preferences and objectives for sustainability. This paper analyzes the underpinning issue how forestry related information and knowledge is perceived, shared and used by community forest users groups (CFUGs) in an adaptive collaborative management context and how social learning might take place in solving the problems with respect to community forest management (CFM). For this purpose we rely on the basic three-step planning processes of the ACM: problem identification, problem modelling and problem solving. That involves the acquisition and analysis of information, represents both the relation between management strategies and outcomes and the design of the management strategies of the community forest management [Kangas *et al.* 96].

## 2 Community Forest Management and Social Learning

Nepal is known as a country of community forestry (CF) and a “learning centre” in the field of participatory environmental governance meeting the twin goals of conservation and poverty reduction. The CF program is launched with collaboration and co-ordination between and among all stakeholders of resource management and tries to find out not only the optimum solution for sustainable livelihood and forest health but for collaboration in problem solving. Community Forestry in Nepal has already passed its infant stage of development and the management system shifted from “passive” (more protection oriented) to “active” (more production oriented) for the overall natural resource management. Although, CF program has been able to restore the degraded landscapes of Nepal since handing over of the forests to local communities, it is unable to provide a significant contribution to the livelihood of poor and marginalized people and equitable use of forests products within the community. In response to community forestry management issues, there is a need to organize the information and knowledge with the engagement of an increased number of stakeholders in problem-solving and decision-making.

As defined by the Center for International Forestry Research (CIFOR), ACM is an ‘engine’ for adaptation and innovation. It is a quality-adding approach to forest management and governance, whereby stakeholders—the people or groups who use, control or in some way have interests in a forest—engage in a process of effective social interaction in which they negotiate a vision for the forests [Fisher *et al.* 07]. ACM also includes learning at a higher level that it is not only individual learning of facts, but also (and especially) social learning—a process in which ‘multiple stakeholders bring together their different knowledge, experiences, perspectives, values and capacities for a process of communication and critical reflection as a means of jointly understanding and addressing shared challenges and potential options [McDougall *et al.* 02]. In essence social learning is the integration of these diverse knowledge bases in ways that enables the adaptation of management.

### 3 Adaptive Collaborative Management Framework

A general goal of the research project was to identify criteria and indicators for sustainable community forest management by involving diverse stakeholders. Specific objectives included the identification, development and critical assessment of conditions, processes and outcomes of social learning and collaborative management approaches to the governance and management of CFs. Six CFUGs in the Chitwan and Makawanpur district of Nepal have been selected as case studies (Table 3-1). The sites can be considered as an average representative of CFUGs in terms of geography, demographics, resources, governance, conflicts and ethnicity. The research combined traditional social and biophysical research methodologies with PAR techniques. Traditional research was the basis for the background studies that enabled us to compare the socio-economic, institutional, forest management and biophysical information in each case study before and after the research activities.

Case study sites	Location	Forest area/ Households	Major Ethnic Groups
<b>Jhirghari</b> (Makawanpur)	Namtar VDC- 2 & 3	560 ha/89 HHs	Hill Ethnic Groups, Tamang
<b>Kalka Chandika</b> (Makawanpur)	Bhaise VDC- 2 & 3,	801 ha/192 HHs	Magar, Tamang, Brahmin, Chettri, Newar, Dalit
<b>Nawalpur Sarswoti</b> (Makawanpur)	Hetauda-11, Basamadi VDC	234 hac/774 HHs	Brahmins, Chhettris, hill ethnic, Dalit
<b>Simpani Deokot</b> (Makawanpur)	Manahari VDC-4	358 ha/389 HHs	Hill ethnic groups, Chhetri, Brahmin, Dalit, Chepang
<b>Pragati</b> (Chitwan)	Shaktikhor VDC- 5	137 ha/137 HHs	Newar, Praja, Dalit, Brahmin, Chhetri
<b>Gyneshwar</b> (Chitwan)	Mangalpur VDC – 1 to 6	234 hac/1660 HHs	Brahmin, Chhetri, Dalit, Terai ethnic, hill ethnics

Table 3-1: Brief summary of case study sites

[Gray and Chan 00] advance a framework that seeks to categorize and integrate these practices into a single model based on the view that the problem-solving process is a vehicle for connecting knowledge and performance - knowledge can generate economic value when it is used to solve problems, explore opportunities and make decisions. Understanding the contribution of various knowledge management practices to problem solving may help integrate the diverse thinking in this area [Gray 01]. Therefore we applied ACM processes to find out the activities of problem identification, problem modelling and problem solving in the context of a knowledge management system (KMS). The KMS helped to manage the identification and generation of knowledge which led to the rise of awareness in the identification of new problems and for the solving of already existing problems. The KMS helped to reduce the overall complexity and uncertainty involved through the transfer and

dissemination of information within CFUGs. The approach supported the transfer of innovation of through the Knowledge Acquisition (KAc), Knowledge Identification (KI), Knowledge Application (KAp), Knowledge Maintenance (KMa), Knowledge Transfer (KT), Knowledge Generation (KG) within an adaptive collaborative management framework (Figure 3.1).

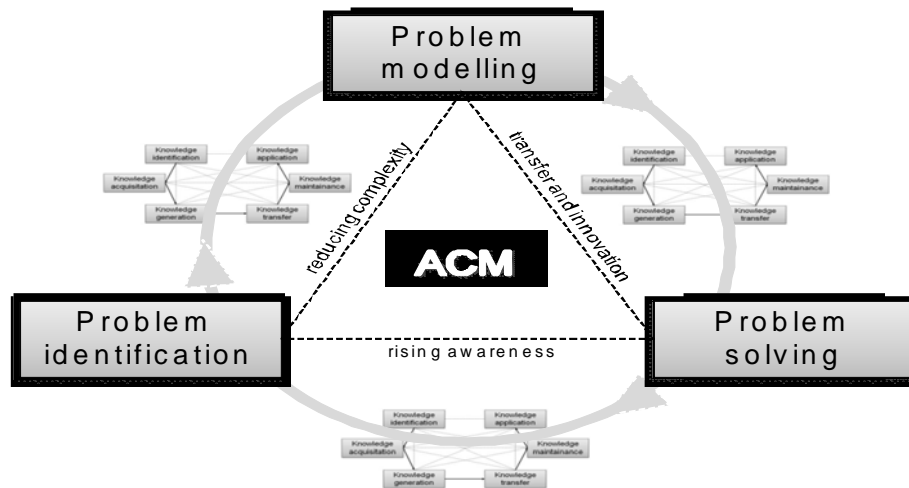

Figure 3.1: Knowledge management system for adaptive collaborative management

The knowledge management activities applied in the ACM process fostered the process of social learning by open communication, multiple stakeholder participation, SWOT analysis, content analysis of policy documents, resource inventory, social mapping, and identification of knowledge sources as well as facilitation training. These activities can be described in a matrix that represents the influence and impact on the status quo for improving the situation of CFUG's in relation to problem identification; modelling and problem solving (compare Table 4-1). The step of problem identification is based on knowledge-based visioning of members of the CFUGs to express their goals and objectives. Stakeholders described new management strategies with a structured view on the identified problem and based on their experiences, knowledge and capacity of the organization. Multi-criteria methods have been proved useful in providing a framework for structuring different aspects of the forest management problem [Ananda and Herath 05]. The visioning workshop, identification of C&I and elicitation of preference for the C&I were major activities in the problem modeling phase. Methods for prioritizing management alternatives in the phase of problem modeling (e.g. for eliciting, scaling and aggregating preferences regarding objectives' weights) are used to select the best management plan [Kangas *et al.* 06]. Qualitative approaches to forest management problem solving were used to project future developments made by stakeholders based on their experiences and expectations. For that purpose, stakeholders convert their qualitative preferences into grades so that management alternatives could be prioritized [Romero and Rehman 87; Pukkala 02; Khadka *et al.* 07].

## 4 Findings and Discussion

In comparing the status quo of the community forest management before and after the PAR we explored some changes in planning and decision-making. A broad range of knowledge management activities helped to share the power between the members of the CFUGs and promoted participatory actions towards achieving the vision of the CFUGs. The general shift in the way how planning and decision making for an integrated forest management is implemented was the heart of the observed changes in our participatory action research (Table 4-1).

Recognizing the increasing complexity of management, some CFUGs have started to adopt various innovative institutional arrangements to facilitate an effective communication, the involvement of all relevant stakeholders in planning and actions, an effective conflict management, the understanding of the difference between "try and error" and adaptive management and develop social capital. In Gyneshwar CFUG, the action groups took on leadership roles, working in coordination with the executive committee and thereby reducing committee control of activities. These groups have even written their constitution and operational plans which became an important aspect of the institutional structure. A key lesson emerging in this regard is that the recognition of sub-groups (such as interest groups or toles (hamlets)) can facilitate the expression of interests, particularly those of the disadvantaged groups leading to more effective and more equitable negotiations [Kaski ACM team, 02].

Knowledge management Activities	Identified system element	Present status	PI	PM	PS
Stakeholder analysis (KAc, KI and KT)	Power dynamics: gender, caste ethnicity, wealth groups	Local elite domination decision making, techno-bureaucracy and multiple actors cause conflicts	+	+	
	knowledge, skills	local knowledge and traditional management practices are present, less motivation for innovation and less political will for management	+		
	Social networking	high numbers of stakeholders but less motivation for information sharing and weak communication mechanism	+	+	+
Content analysis of constitution and Operation plan (KAc, KI, and KMa) and SWOT analysis (KI, KAp, KMa, KI and KG)	Institution structure	existing executive committee and sub committee but no proportional representation, committee is overburden	+	+	+
	Socio-economic	injustice membership fee, low participation of women and marginalized groups in decision making and other incentives, male and wealthier groups domination in representation	+		+
	Bio-physical	lack of vision, goals and objectives, protection oriented management, block division, high demand of users can't be met	+		
	Policy framework/institution	ad hoc linear planning and decision making, top-down decision making dominated by executive committee (chairperson)	+		
Social mapping (KAc, KI and KMa) and heterogeneity analysis (KI, KAp, KMa, KI and KG)	Fund mobilization and management	poor documentation, focus on community development and infrastructure, low budget for poverty reduction and income generation activities	+	+	
	Development infrastructure	weak infrastructure and building of CFUGs	+	+	
	resource mobility, access	high pressures on forest	+	+	
Participatory resource mapping (KAc, KI, Ka, KMa, KI and KG)	Settlements	scattered settlements	+		
	Conflict on resource uses and preferences	conflict in resource uses, the interest and preferences of diversified stakeholders	+	+	+
	Forest condition	medium and less pole size tree, over mature tree and sapling domination, species diversities	+	+	+
Workshop/ Training (KAp, K and KG) and C&I Development (KI, KAp, KMa and KG)	Management issues and objectives	conventional management system, subsistence, no silvicultural operation and treatment, no specific objective and action plans for block management		+	+
	Awareness building	low awareness level, weak communication mechanism, less sharing and reflections, less exposure and issues for management	+		+
	C&I development	no holistic management approaches, no specific mechanisms for monitoring	+	+	+
Management strategy development and implementation process		less consistency in actions and objectives of management plan, not properly following the prescription of management, less interventions for forest management		+	+
<b>Total</b>			<b>15</b>	<b>11</b>	<b>9</b>

Note: (+) supports Problem identification (PI), Problem modeling (PM) and Problem solving (PS)

Table 4-1: ACM interventions, practices, present status and social learning patterns

In response to an increased awareness for the need of more equity in CFUG decision making, all six CFUGs made changes to the balance of gender, caste, ethnic and/or wealth groups on their executive committees. Most groups identified these changes by their prescription of goals and indicators. Gyaneshwar CFUG made them

official in their revisions of CFUG rules and reformed their institution which might enable them to institutionalize these provisions on the long-term.

The networking between district forest officers and users helped to recognize the value of social learning in the process of applying the ACM approaches, but failed to identify the various types of interconnections necessary. For example, research units of central department and district forest officials fail to encourage two-way vertical connections at Nawalpur Sarswoti CFUG. Members of the CFUG could not benefit from the establishment of silvicultural and bio-diversity conservation demonstration plots for experimental learning and the communication within and among the communities and outsiders. They also failed to communicate new initiatives of plot distribution to women groups which were important for the income generation activities of the poor and marginalized groups. In this case, the ACM approach created the opportunity to build the linkages downwards and upwards within the community and was subject to a regular quality improvement of their programs and increased the social learning.

ACM supported the identification and structuring of decision problems. The processes were supported differently, as the PI phase was supported 15 times, the PM phase 11 times and the PS 9 times. Knowledge storage and knowledge management strategies, production and distribution patterns of resources, assessment of the traditional and indigenous knowledge of users, empowerment and welfare of community members allowed social learning and recommendations for future policy implications. The study provided a new insight of ACM process for social learning in community-based institutions, their knowledge for problem solving and information for decision-making process at Gyneshwar CFUG (Table 4-1). For instance, decision support systems could help to organize the decision process and provide flexible, on-demand access to the full array of methods and tools applicable to a particular problem situation [Rauscher *et al.*, 06]. In this context a "good" decision is one that is made based on a thorough understanding and analysis of the problem [Holloway, 79]. There is no guarantee that a good decision will always achieve a good outcome in terms of sustainability. The consequences of a "good" outcome are favourable with respect to the preferences of the decision maker. A decision resulting in a bad outcome could still be considered a good decision as long as the decision-making process indicated the possibility of a bad outcome. The presented ACM approach provide a proper documentation of the decision making process. Thus, rationales and information used in arriving at a decision can be compared with the achieved outcome, which enables better decisions in the future.

## 5 Conclusions

Adaptive collaborative management and social learning play an important role in influencing change, and sustaining a social and institutional environment, power balance and operational provisions of resource management that contributes to the improvement of the forest condition and people's livelihood. ACM process helped CFUGs become more effective and responsive learning institutions and become more active and more successful in meeting their goals. The process of mindfully engaging in the C&I development process and provides 'breaks' in systems thinking and improve the overall performance of the management system and promote social

learning. Based on this, we suggest that applying ACM approaches in analyzing and facilitating CFM at various levels could be a very useful means of enhancing the effectiveness of social learning, including the opportunities for knowledge management within and between institutions. In each of these aspects, we also noted a variety of innovations that have emerged, including various monitoring practices, decentralizing decision-making processes, activities for power sharing, provision and proportional representation of members in decision making processes. Much progress can be made relatively rapidly by drawing new boundaries of knowledge or by connecting existing data, information, and knowledge in new ways [e.g. Vacik *et al.*, 07]. A new data, information, and knowledge are created; we can use our KM activities and tools to rapidly integrate new content into the existing body of knowledge. We can also share that content cheaply, widely, and immediately. There is no doubt that such integration is technologically feasible, what is missing now is a shared vision and the political will to implement it in Nepal.

ACM is oriented to identify opportunities on which forest users and researchers could improve local condition of forest, maintain biodiversity, conserve soil and water, promote livelihood, governance and institutional changes in the context of integrated resource management. ACM approaches have paid less attention to identify the problems and solve it within knowledge management activities. The ACM approach we proposed in this contribution is concerned about social justice, inclusion, equity and enables an environment for social learning. This is made possible through devolving responsibility, and increasing horizontal relationship among stakeholders for problem identification, modelling and solving the relevant problems of the people. In order to additionally value community forest management, ACM approaches should focus on biodiversity, landscape, climate change and other political ecological issues by considering concepts for dealing with uncertainty, complexity, chaos and knowledge based decision making theory.

### **Acknowledgements**

The Authors thank two anonymous reviewers for their constructive comments. We thanks for the financial support by the Commission for Development Studies at the Austrian Academy of Science (KEF-ID 150, Austria). Special thanks to active members and leaders of CFUGs, researchers (especially Hima D. Uprety), representative of project partners (MoFSC, FECOFUN, RRN, NORMS). We also thank to North- South Dialogue Program (OEAD, Vienna) for providing the financial support for the doctoral study.

### **References**

- [Allen et al. 02] Allen, W.; Kilvington, M., Horn, C.: Using participatory and learning-based approaches for environmental management to help achieve constructive behavior change. Landcare Research Contract Report LC0102/057, Lincoln, New Zealand. Available from: [http://www.landcareresearch.co.nz/research/social/par\\_rep.asp](http://www.landcareresearch.co.nz/research/social/par_rep.asp)
- [Ananda and Herath 05] Ananda, J., Herath, G.: Evaluating public risk preferences in forest land-use choices using multi-attribute utility theory. *Ecological Economics* 55, 408-419.

- [Fisher et al. 07] Fisher R., Ravi Prabhu and Cynthia McDougall.: Adaptive Collaborative Management of Community Forests in Asia Experiences from Nepal, Indonesia and the Philippines, Center for International Forestry Research (CIFOR), Indonesia in Nepal, Indonesia and the Philippines. CIFOR ACM Research Report. CIFOR, Bogor, Indonesia.
- [Gray 01] Gray, P.H.: A problem-solving perspective on knowledge management practices: School of Business, Queen's University, Room 111, Dunning Hall, Kingston, Ontario, Canada, *Decision Support Systems* 31 (2001) 87–102.
- [Gray and Chan 00] Gray, P.H. and Chan Y.E.: Integrating knowledge management practices through a problem-solving framework, *Communications of the AIS* 4 (12) 2000.
- [Khadka et al. 07] Khadka, C., Kandel P., Vacik H.: Criteria and Indicators for community based sustainable forest management - Case study from Nawalpur Saraswati (Basamadi) Community Forest User Group, Makawanpur District, Nepal. In: *Organization Committee of Ecosystem Summit 2007 (Eds.), Ecological Complexity and Sustainability - Abstracts of EcoSummit 2007*, p 150, 22.05-27.05.2007, Beijing.
- [Kangas et al. 06] Kangas, A., Laukkanen, S., Kangas, J.: Social choice theory and its implications in sustainable forest management - a review. *Forest Policy and Economics* 9/1, 77-92.
- [Kangas et al. 96] Kangas, J., Loikkanen, T., Pukkala, T., Pykäläinen, J.: A participatory approach to tactical forest planning. *Acta Forestalia Fennica* 251, 25 pp.
- [Kaski ACM Team 02] Kaski ACM Team.: Adaptive and collaborative management in community forestry final report: the case of a participatory action research in Bamdibhir and Deurali-Baghedanda forest user groups in Kaski District, Nepal. ACM Research Project Final Field Report 2002.
- [Holloway 79] Holloway, C. A.: *Decision making under uncertainty: Models and choices*. Prentice Hall, New Jersey.
- [McDougall, 02] McDougall, C., Kaski ACM Team, NewERA ACM Team and Forest Action.: Planning for the sustainability of forests through adaptive co-management: Nepal country report. ACM Project/MoFSC Internal Research Report. CIFOR, Bogor
- [Pukkala 02] Pukkala, T., (Ed.): *Multi-objective forest planning*. Kluwer Academic Publishers, London.
- [Rauscher et al. 06] Rauscher H.M, Schmoldt D.L., Vacik H.: Information and Knowledge Management in Support of Sustainable Forestry: a Review In: Reynolds K., Rennolls K., Köhl M., Thomson A., Shannon M., Ray D. (Eds.), *Sustainable Forestry: From Monitoring and Modelling to Knowledge Management and Policy Science*, 439-460; CAB International, Cambridge;
- [Romero and Rehman 87] Romero, C., Rehman, T.: Natural resources management and the use of multiple-criteria decision making techniques: A review. *European Review of Agricultural Economics* 14/1, 6-89.
- [Vacik et al. 07] Vacik H., Wolfslehner B., Seidl R., Lexer M.J.: Integrating the DPSIR approach and the analytic network process for the assessment of forest management strategies. In: Reynolds K., Rennolls K., Köhl M., Thomson A., Shannon M., Ray D. (Eds.), *Sustainable Forestry: From Monitoring and Modelling to Knowledge Management and Policy Science*, 393-411; CAB International, Cambridge

## **KAJAL – An Algorithm for Workflow Navigation in Informal Learning**

**Eicke Godehardt, Markus Doehring, Andreas Faatz, Manuel Goertz**  
(SAP AG, Germany, SAP Research CEC Darmstadt, Germany  
{eicke.godehardt, markus.doehring, andreas.faatz, manuel.goertz}@sap.com)

**Abstract:** The more information a knowledge worker has to handle, the more (informal) learning is needed right at the workplace. This paper describes an algorithm that enables users to explore their current workflow, jump and navigate through their own tasks (even future ones), for informal learning or help purposes. This is done by overlaying the real workflow with a cloned one, providing an interface to access additional information, like prerequisites, associated documents or expert contacts. In particular, we developed KAJAL, which is a Petri net formalism to cope with the question of determining the states after a jump to a future task was triggered during the user's navigation.

**Keywords:** informal Learning, workflow, workplace-embedded learning

**Categories:** L.3.2, L.3.4, L.3.6

### **1 Introduction**

Informal e-learning [Ley05] means learning activities without a pre-defined support by electronic curricula or textbooks. Informal learning environments like the prototypes described in [Lin05] can be closely embedded into the working place and can be related to the order of tasks a worker wishes to fulfill on the job. That means that a worker's workflow guides the training measures, i.e., tasks in that workflow have a connection to electronic learning material. Informal e-learning is at the frontier to context-aware help, which denotes any kind of IT-based help system, that changes due to the state an application is in. This context-awareness can be established/expressed by the state of a workflow.

This paper aims at navigation in informal learning environments. The strict conduction of a workflow is supplemented by a modus, which allows the exploration of a workflow keeping as most as possible of the current workflow state a worker is in.

Consider for example the following workflow in figure 1 as a possible learn and work status. Each task might have documents attached to it, which explain or train the purpose and the actions of that task.



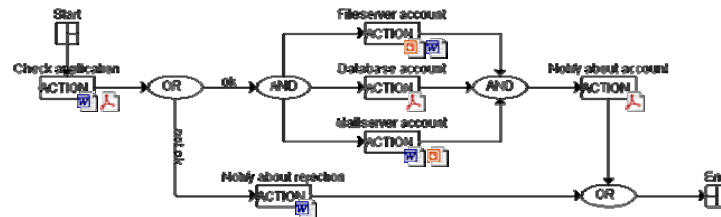

Figure 1: Example workflow with associated documents or learning resources per task (source: <http://www.ultraflow.de>)

Its middle parts include actions regarding fileserver, database and mail server accounts. These actions are only started, if “check application” returned the state “ok”. Even if a worker is actually in the middle of such a workflow, s/he sometimes requests training material about a future task (and they really do), which might leave the strict conduction of the workflow. The offered training material could still be provided by an LMS (learning management system) and the effect on the user’s skill will be the same, no matter if the user is in working mode or just learning.

KAJAL (**keeping states in arbitrary jumps and learn**), the system described in this paper, generates a view of the selected task, which is as similar as possible to the worker’s workflow view before the selection. For example, if s/he already checked the fileserver and database account, the preferable situation after the jump to “Notify about account” will be resulted from the assumption, that the mail server account has also been checked – instead of assuming, that the worker will follow the bottom path of the workflow and undertake more different actions. KAJAL presents an approach to formalize this notion exactly and restrict the complexity of the decision, what a state-based similarity of workflows means.

Similarly, if a context-aware help system or informal e-learning material is depending on the working task, the worker might prefer a kind of help, which considers her/his current context but also keeps the logic of the workflow. Thus by jumping into a task for explorative reasons the help under the operating KAJAL would not change disruptively. For instance, if the user never passed the branch in the above illustration, which is about “notify about rejection”, KAJAL would prefer states of the workflow resulting from the passage of the three branches in the middle of the illustration.

This paper describes a formalization of the approach. It is based on state-based representations of workflows. An example for state-based representations of workflows is YAWL, which we will use for illustration. Workflows in any other workflow language, which can be translated to Petri nets, can be subject to KAJAL as well.

The presentation of KAJAL’s results will always be shown by cloning the actual view or screen, i.e., keeping the original graphical user interface and opening a second one, where an interaction under the assumptions and results of KAJAL is possible. This is depicted in figure 2, where the view is cloned from the original view. The target view shows the position of the jump (marked by a dotted frame), while the

initial view shows the initial position (marked by a frame). KAJAL provides the background states for the target view.

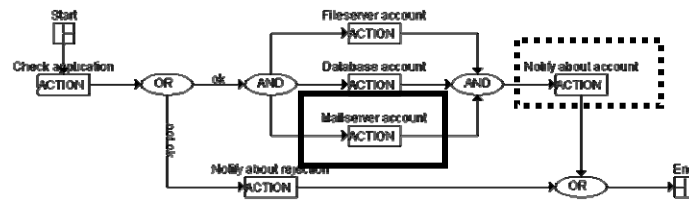

Figure 2: Cloned view on the workflow, to which KAJAL computes states in the background (source: <http://www.ultraflow.de>)

This paper is organized as follows. We will introduce basic workflow constructs and definitions first. After presenting related work, we will explain our algorithm. At the end we will finish with a conclusion and future work.

## 2 Workflows: basic concepts and definitions

We first want to define several (workflow) concepts, especially from the YAWL point of view.

**Workflow:** We explain the concept of a workflow by the example of YAWL [AH05]. Basically, a workflow in YAWL consists of tasks ordered to sequences, parallelism and controlled branches by AND, OR and XOR gates. This set up and the following constructs make YAWL translatable to a Petri Net [Aal02]. Note that we use only the control flow part of workflows (data passed between tasks is not taken into account).

**Task:** A task is a working step. Tasks can be compared to a transition in Petri-Nets, including the firing behavior (consumption and production of tokens). In YAWL, we can assign an action, e.g., a human, to a task.

**Composite Task/Subnet:** It is possible in YAWL to structure workflow definitions hierarchically. This is done by means of composite tasks, which act as a placeholder for other autonomous workflow definitions. The autonomous workflow definition in a composite task is also called a subnet.

**Condition:** Similar to conditions in Petri-Nets, YAWL conditions represent states within a workflow. If two tasks are directly connected with an arc, conditions can be seen as implicitly presented between these two tasks. In YAWL, the extended concept of Colored Petri-Nets (see e.g. [Jen97]) is used. That means a condition may contain multiple tokens that carry different information (e.g., necessary to distinguish between multiple workflow instances).

**User context:** Any information that characterizes the user's current situation and that is important for the interaction between the user and the application. Context-aware systems use this context data to offer relevant information and/or services.

### 3 Related work

There are some related research projects in using workflows for learning. But none of them is workplace embedded or focusing on informal learning based on workflows. Cesarini et. al. [Ces04] uses workflows to model and structure e-learning content. In a similar manner [Kwa05] tries to use the greater flexibility for structuring e-learning content to enhance SCORM based content. Another project [Bru97] is also not workplace-embedded, but uses workflows to model traditional learning content to make it more adaptive. All of these approaches do not have the goal to integrate learning into the workplace and thus still stick to fixed roles for learners and teachers in a dedicated e-learning environment. Also APOSDLE [LGF07, GDF07] as a prototype of an informal learning environment that tries to bring these different roles of work, learn and teach together, has until now no mechanisms like the ones described in this paper, as the strictness of the workflows applied there is rather weak from a control flow perspective. Consequently, no system like KAJAL was designed for these environments.

In the domain of context-sensitive help the works of [DJH04] has proven fruitful, but was rather applied to classical tutorial situations than to workflow-oriented help, i.e., concrete workflow models are not taken into account.

## 4 Description of the algorithm

### 4.1 Assumptions and principles

We assume that the user follows a workflow and has a graphical view (i.e., screen) about his/her possibilities. The example graphical view is YAWL, but KAJAL works for any workflow language, which can be formally expressed as a Petri net.

The normal course of following a workflow is that the worker/user processes the enabled tasks, enabling new tasks, which can be processed again. The goal of KAJAL is to offer an alternative modus of operating the workflow: leaving the enabled tasks, i.e., jumping to a task, which is not necessarily enabled. The alternative modus triggered by a jump and computed by KAJAL is displayed on a second screen or view as depicted in figure 2. In the above example, if the user would jump from “ACTION: file server account” to “ACTION: notify about account”, a screen for the initial state of the workflow at “ACTION: file server account” would remain and a second screen at “ACTION: notify about account” resulting from KAJAL computations would open. This process walkthrough for learning purposes is intended to provide a feature for the informative examination of workflows (in contrast to live-execution). The user instantiates a kind of “dummy workflow” and navigates through it for a better understanding of the process itself, its internal dependencies and its corresponding work items. For example, s/he could select a task and the system would show up the next possible steps s/he could take subsequently. By manually selecting process steps which seem interesting to him/her, s/he is also able to access the linked material and expert contacts. With the help of the desired “arbitrary jumping” functionality, s/he does not have to run through the whole process if – for instance – s/he is interested in a work item at the end of the workflow. Besides this benefit for jumping once, KAJAL can be exploited for the design of a context-sensitive help: typically, textual

help descriptions give the opportunity to jump in many different tasks the user has not been into. KAJAL will open the respective “dummy workflow” finding the most similar overall picture of the workflow in terms of conditions. All this only holds, if the net never deadlock and do not contain any tasks which are never enabled.

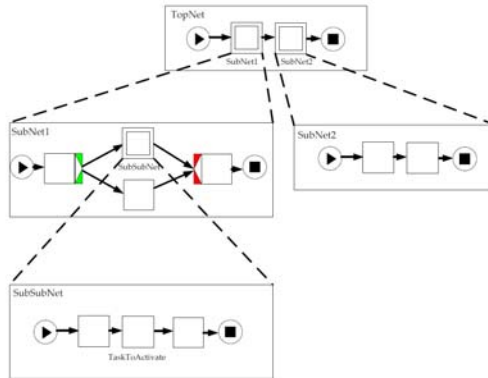

Figure 3: Example hierarchical workflow

## 4.2 System

We assume that the system starts with no input information except the concerned task ID (indicating the intended task to jump to) and the instance of the workflow. Since we assume that the target task ID only exists once, the reuse of decompositions (i.e., the assignment of single nets to multiple composite tasks) has to be prohibited.

The initial step now is to determine where the task is exactly situated within the workflow hierarchy of YAWL nets. To give a comprehensive example for the reader, figure 3 contains a hierarchical YAWL workflow. The tree consists of three stages, and four nodes. If we want to enable the “task-ToActivate” for instance, this presumes that the composite tasks “Subnet1” and “SubSubNet” are currently executing. If one of those nets is inactive, any attempt to enable the taskToActivate is doomed to failure. That is the reason why it is necessary to gather all involved nets from the root net of the workflow down to the net which contains the target atomic task.

A recursive search is performed to traverse the hierarchy and to determine the path to the desired task. As an example, the determined path for the TaskToActivate of figure 3 would be  $\text{TopNet} \rightarrow \text{SubNet1} \rightarrow \text{SubSubNet}$ . The resulting path to the jump task is run through from top to bottom. For each net, three main steps are executed which are described below. The first step is to determine all “allowed” states of the currently processed net. Figure 4 contains a simple YAWL net which serves to demonstrate the characteristics of such a state more specifically. In this figure, A, C and D are OR splits/joins while B and E are AND splits/joins. Please note, that the conditions  $c_1, c_2, c_3, c_4, c_5, c_6$  and  $c_7$  do normally not have to be explicitly displayed within a YAWL diagram (see above). For our demonstration purposes it is anyhow inalienable to imply them in the diagram.

The state of a YAWL workflow net can be described in terms of the amount of tokens within each condition. The notation “ $nc_i$ ” means, that condition  $c_i$  contains  $n$

tokens. If for instance  $c_6$  and  $c_7$  of the YAWL net in figure 4 contain a token (which would enable task E),  $1c_6;1c_7$  unambiguously characterizes the current state of the net. We will keep this denotation and from now on speak of a particular marking of a net.

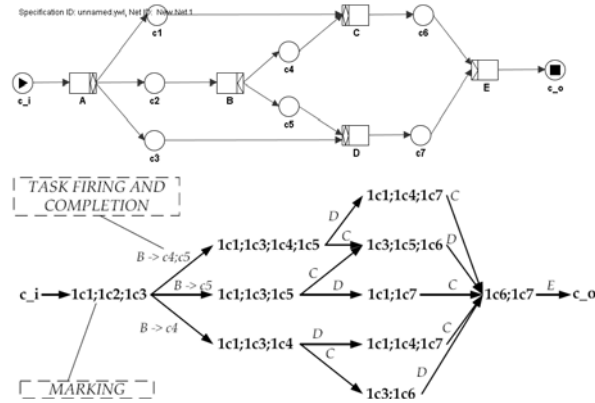

Figure 4: Example YAWL net and the corresponding reachability graph

From all possible markings of a net, only a subset is relevant for our purposes. Solely the reachable markings have to be considered, since all other markings do not stand for a valid state of a YAWL net. The reachability of a marking determines whether there exists an execution order of tasks within a YAWL net that leads to the concerned marking. The whole subset of reachable markings can be gained by generating the finite reachability graph of a net. For our example above, the corresponding reachability graph is shown in the lower part of figure 4. One can see that there are twelve possible markings and six possible execution orders. Details about reachability analysis can be found in [Wyn06].

At this stage of the system, we dispose of a set of markings for each determined net on the path to the jump task. As a second step, the “best” marking for each net that should be realized has to be filtered out. For this purpose, the set of markings for each net is processed by a five-tier ranking system.

*Tier 1 – Enabling of obligatory task:* Within each net, there is exactly one task which necessarily has to be enabled by the desired marking. Within nets from upper levels of the hierarchy, this concerns the composite task which is decomposed to the net of the next level. Within the leaf net, this corresponds to the atomic task we intend to jump to. In figure 3 for example, the obligatory tasks are SubNet1, SubSubNet and TaskToActivate. All markings that do not enable the obligatory task are filtered out.

*Tier 2 – Congruency of enabled tasks:* It might be the case that more than one marking has passed the above tier of the ranking system. For this situation, it is intended to select the target marking which is most “similar” to the current marking. Similarity measures can be defined in the following ways:

(i) the size of the enabled task intersection of the initial marking and the target marking. That means markings which preserve most of the enabled tasks are preferred.

- (ii) the average number of steps a token would have to pass along the shortest way in a graph spanned by places and tasks as vertices and transitions as edges.
- (iii) any weighted version of (i) or (ii).
- (iv) any hybrid of (i), (ii) or a case of (iii), for example established as a weighted sum of the corresponding figures or scores.
- (v) the system might rank markings as more similar, which already occurred while the workflow was executed in real.

*Tier 3 – Amount of enabled tasks:* If there are still multiple markings left after tier 2. The markings which generally enable the highest number of tasks are chosen. (optional step)

*Tier 4 – Amount of tokens within the marking:* Any marking arriving this tier is examined regarding the amount of tokens it is going to realize. The marking with the overall highest number of tokens are chosen. (optional step)

*Tier 5 – Consistency criterion:* In very unusual situations, it is possible that even at this last stage, several equivalent markings are left. Though it is not a semantically valid criterion, we have to ensure determinism and unambiguousness of the system. We therefore introduce a last consistence criterion responsible for the determination of a single marking. The consistency might be established by alphabetical order or by applying an additional criterion from the list we provided in Tier 2 (i)-(v).

### 4.3 Instantiate the new marking

For the third step of KAJAL's net processing part, the path to the jump task together with the best marking for each involved net is available. Up to this step, it was not necessary to do any changes to the actual workflow. All computations could be performed in a kind of sandbox, only requiring reading access to the workflow engine. Now it is time to transform the running workflow's state. The first action for each net is to reserve the tokens of the target marking that are consumed when the obligatory task fires. Then all running tasks of the currently processed net are examined. All running atomic tasks are canceled in the first place. For composite tasks, the treatment depends on the target marking. If they are enabled by the target marking, we simply remove the tokens that would be needed to fire the corresponding task. We therefore allow the running subnet of the composite task to remain unchanged. If the target marking does not allow the composite task to be in an executing state (for it would not even be enabled), it is completely canceled together with its running subnet.

At last, every condition of the currently processed net is synchronized with the up-dated target marking. The tokens reserved for firing the obligatory task are thereby naturally included. If an obligatory composite task gets enabled, it is automatically fired by the engine. We therefore do not have to manually take care about it. Having run through all involved nets, it is finally possible to fire the atomic jump task.

## 5 Conclusion and future work

We have presented an approach for determining target states of workflows based on Petri-Net formalisms for performing arbitrary jumps between tasks. Generally, we thereby increase the possible degree of dynamism in workflows while simultaneously keeping the benefits of their formal restrictedness. The main advantage of our algorithm is the utilization of an adjustable ranking system for target workflow states in cases where several states are possible to activate the jumping task. Therefore, the “history” of a workflow, e.g., in terms of past user behavior, is included in the determination of the most suitable jumping state.

The jumping functionality can be especially utilized in informal learning environments. For example, it may support navigation and exploration, allowing “what-if-analyses” for the user, who can in turn examine the consequences of activating a task. With the concept of a supporting system for knowledge workers in mind, this could also imply the provision of related documents or expert contacts assigned to the particular task. It is noteworthy that this can be achieved by non-invasive means regarding the currently running workflow, simply by instantiating a second “dummy” workflow and applying our algorithm on that copy.

However, there are some important issues to be addressed in future. First, we completely focused on the control-flow perspective for the development of our jumping algorithm and abstracted from data-flow concerns. That means the actual data assigned to net variables is not taken into account when performing an arbitrary jump. Undesired data-flow behavior may be a possible result. For example a “backward” jump might be performed to re-execute a task which has already been completed. When the re-executed task has finished, it eventually overwrites some net variables with its produced data. This might lead to inconsistencies within the data flow.

Second, the calculation of the complete reachability graph may take unacceptable computation times when particular patterns occur in the workflow (mostly related to a large number of outgoing arcs from a task). An imaginable solution would be to calculate the reachability graph in advance at design time and to prune the computation when an “adequate” state has been obtained (It would then be necessary to consider when a target state can be called “adequate”).

Corresponding experiments and the concretization and formulation of solution approaches to both data-flow and runtime issues are ongoing, as well as an evaluation of the described concepts, e.g., in a knowledge intensive working environment.

## References

- [Aal02] van der Aalst, W.M.P.: Making Work Flow: On the Application of Petri nets to Business Process Management. In: Lecture Notes in Computer Science vol. 2360, Springer-Verlag, 2002, p. 1–22.
- [AH05] van der Aalst, W.M.P; Hofstede, A.H.M. T.: YAWL – Yet Another Workflow Language. Information Systems vol. 30. Orlando/New York: Elsevier Ltd., 2005, p. 245–275.
- [Bru97] Brusilovsky, P., Schwarz, E and Weber, G.. A tool for developing adaptive electronic textbooks on www. Proceedings of WebNet, 1996.

- [Ces04] Cesarini, M., Monga, M, and Tedesco, R.. Carrying on the e-learning process with a workflow management engine. Proceedings of the 2004 ACM symposium on Applied computing, Nicosia, Cyprus; 2004.
- [DJH04] Deacon, A., Jafta J. Horwitz, D. Customising Microsoft Office to Develop a Tutorial Learning Environment, *British Journal of Educational Technology* 35 (2), p223-234 Mar 2004.
- [GDF07] Eicke Godehardt, Markus Doehring, Andreas Faatz, and Manuel Goertz. Deploying YAWL for Workflows in Workplace-embedded Learning. 7th International Conference on Knowledge Management, pages 281–288, September 2007.
- [Jen97] Jensen, Kurt: *Coloured Petri Nets*. vol. 1. edition 2. Springer-Verlag, 1997.
- [Kwa05] Kwang-Hoon Kim, Hyuk-Hyae Hoo, and Hak-Sun Kim. A process-driven e-learning content organization model. In *ICIS '05: Proceedings of the Fourth Annual ACIS International Conference on Computer and Information Science (ICIS'05)*, pages 328–333, Washington, DC, USA, 2005. IEEE Computer Society.
- [Ley05] T. Ley, S. Lindstaedt, and D. Albert. Supporting competency development in informal workplace learning. In *Lecture Notes in Artificial Intelligence*, number 3782, 2005.
- [LGF07] Robert Lokaiczkyk, Eicke Godehardt, Andreas Faatz, Manuel Goertz, Andrea Kienle, Martin Wessner, and Armin Ulbrich. Exploiting context information for identification of relevant experts in collaborative workplace-embedded e-learning environments. In *Proceedings of EC-TEL'07*, September 2007. *Proceedings of EC-TEL 2007*.
- [Lin05] S. N. Lindstaedt, T. Ley, and H. Mayer. Integrating working and learning with aposdle. In *Proceedings of the 11th Business Meeting of Forum Neue Medien*, 10–11 November 2005, Vienna. Verlag Forum Neue Medien, 2005.
- [Wyn06] Wynn, M. and Thandar, K.: *Semantics, Verification, and Implementation of Workflows with Cancellation Regions and OR-joins*. Brisbane: Faculty of Information Technology, Queensland University of Technology, 2006.



## **Extending Low Level Context Events by Data Aggregation**

**Robert Lokaiczky**

(SAP Research, Germany  
robert.lokaiczky@sap.com)

**Manuel Goertz**

(SAP Research, Germany  
manuel.goertz@sap.com)

**Abstract:** Providing context-aware personalized desktop assistance that is related to the work task of the knowledge worker is a recent research topic. Our approach focuses on task detection by work context observation. A sum of steps towards this goal are addressed by our work, including (1) accessing the desktop computers event stream of user interaction and system status, (2) context reasoning and prediction of the user's working task and (3) recommending relevant resources based on the predicted work goal. Here, we present an algorithmic approach for automated context aggregation by using mapping functions. This instance of context inference combines lower-level context features to new aggregated features which represent a higher-level context. While related work uses manually defined domain-specific rules for combining features, we automate this approach and in addition show that by means of that the prediction accuracy of the user's work task increases significantly.

**Key Words:** context-aware systems, machine learning, task inference

**Category:** H.3.4, H.5.2

### **1 Introduction**

Most current personal information and knowledge management systems take the knowledge worker's context, especially his work task, into account [Kessell and Chan, 2006], [Shen et al., 2006]. The vision of electronic assistants that continuously adapt themselves to the implicit user's information need and the surrounding situation has been carried over to the electronic learning community in the manner of workplace-embedded recommendation systems [Zaiane, 2002]. Those systems provide the user with suitable learning resources relevant for the current work task.

The key success factor for automated task inference is user's context. To deliver learning resources to the user which are both suitable and helpful with regards to the user's current work situation, the information system always has to consider the learner's actual work task, his environment, and history. Forms of workplace-integrated learning support might be displaying a list of task-relevant documents in a corporate environment (standards, policies, examples, definitions) but also learning object from open repositories. But in order to infer relevant learning material the system needs to know what the worker is currently working on - the current work task. Systems like [Mayer et al., 2005] and [Grebner et al., 2007] will then infer relevant resources determined by a semantic network given a description of the current work task. Therefore,

we aim at determining the current work task of the knowledge worker precisely and automatically only by means of available context information on the desktop and not by manual user input.

This paper structures as follows: In Section 2 we define our understanding of desktop context. This is the grounding of a context-based task classification of the user's work task (Section 3). Since this paper focuses on task elicitation we describe the feature aggregation algorithm (Section 3.1) and the mapping functions (Section 3.2) in-depth. Thereafter we evaluate the accuracy of our algorithm and show the achieved improvements (Section 4.2). Before giving an outlook on possible extensions, we compare our approach to related work.

## 2 Context Observation

There are a number of different definitions for the term *context* spread in different research communities (see [Brezillon, 1999, Zimmermann et al., 2007]). Since we focus on knowledge-intensive work on the desktop of the computer worker, we define *Desktop Context* as environmental settings that surround the user desktop work and have a measurable impact on the user's work task. These settings are observed by desktop context sensors that collect system events and user interaction with the workbench. The context sensors are implemented as software hooks that operate on operation system level and log the user's desktop work continuously. This way our context elicitation layer is unobtrusive and updated regularly. For an overview on what context sensors are used and how they are filtered see [Lokaiczky et al., 2007].

Figure 1 shows the structure of a typical desktop event that can be used as an indicator for a certain task in a certain domain. For further processing we consider the event stream of collected desktop events as a reflection of the user's working process.

```
<event name="IE_CHANGED" type="Browser"
      timestamp="11-5-2007 15:13:11">
  <attribute url="http://www.uml.org/" />
  <attribute title="Object Management Group"/>
  <attribute importantTerms="OMG, UML, Tools,
                            Resource, Modeling"/>
</event>
```

**Figure 1:** Example: XML-Representation of a Desktop Event

Tasks are then seen as slices of the serial event stream consisting of typical events or event patterns. Since context events can include keystrokes, program starts and full-text

```
do
  foreach combination(f1,f2) of features do
    new feature = aggregate(f1,f2)
  end
while ( max(IG_growth(all new features)) >
       max(IG_growth(features of last iteration)) / 2 )
```

IG: Information Gain

**Figure 2:** Pseudo code: Context Aggregator Algorithm.

of documents, the sequence of context events can be interpreted as a realistic reflection of the knowledge worker's actions during the work process. Based on the collected context information we then infer the user's work task.

### 3 Aggregating Context Events

[Lokaiczuk et al., 2007] understand the problem of task detection as a machine learning classification. The key idea is first to collect a reasonable amount of training data acquired by manual work task selecting during the work process. In this step, the knowledge worker picks a task from a pre-modeled task list defined by a domain expert. The task label is then annotated to the collected event stream. At this moment, it is possible to build a task prediction model with a machine learning classifier. Afterwards, the knowledge worker is able to continue her work process and she does not need to manually notify the system of task switches anymore. During this phase of automated task inference the classifier tries to detect changes in the knowledge worker's current task. As a result task-relevant resources or lists of associated learning resources are displayed.

#### 3.1 Aggregation Algorithm

Currently most approaches of aggregating desktop events to more complex, meaningful units are manually handled by the user or previously modeled by domain experts. We present the idea of unsupervised context event aggregation (Figure 2) that reduces the manual modeling effort by automated event aggregation and relevance measurement. As a consequence this algorithm is not dependent on domain-specific knowledge, but could be extended easily with further domain-specific aggregation functions.

The basic idea is to create new context events by combining simple desktop events. The resulting aggregated feature is potentially more valuable for work task prediction.

As a relevance measure we use the information gain increase [Mitchell, 1997] compared to the basic features. The combination of features is a well established method in the machine learning community for increasing classification performance. Intuitively speaking, if you know that the knowledge worker used a program like Microsoft Visio and dragged and clicked a lot in the current time slice in an open document named activity diagram for UC12.vsd, it appears more plausible to predict the task *Create UML activity diagram* than basing this decision on solely one of this features.

### 3.2 Mapping Functions

Still, this raises the question which strategy combines the features most advantageously. We propose a set of combination functions that map a number of simple features  $n$  to a aggregated feature (equation 1) and appear to be very prospering for our particular context aggregation problem.

$$f_i : F^n \rightarrow F \quad (1)$$

We implement  $f$  with several mapping functions which are grouped into this categories.

#### logical functions

$$f_1(event_1, event_2) = event_1 \text{ AND } event_2$$

$$f_2(event_1, event_2) = event_1 \text{ OR } event_2$$

$$f_3(event_1, event_2) = event_1 \text{ XOR } event_2$$

$$f_4(event_1) = NOT \ event_1$$

#### frequency functions

$$f_5(event_1) = \text{number of occurrences of } event_1 \text{ }^2$$

$$f_6(event_1) = \text{percentage of } event_1 \text{ }^2$$

$$f_7(event_1) = \text{existence of } event_1 \text{ }^2$$

$$f_8(event_1) = \text{existence of category}(event_1) \text{ }^2$$

#### temporal functions

$$f_8(event_1, event_2) = event_1 \text{ appears before } event_2$$

$$f_9(event_1) = \text{time since last appearance of } event_1$$

#### structural functions

$$f_{10}(event_1, \dots, event_n) = \text{all events appear } \text{ }^2$$

$$f_{11}(event_1, \dots, event_n) = event_1..event_n \text{ appear in sequence } \text{ }^2$$

$$f_{12}(event_1, \dots, event_n) = event_1..event_n \text{ appear in strictly successive order}$$

---

<sup>2</sup> in considered timeframe

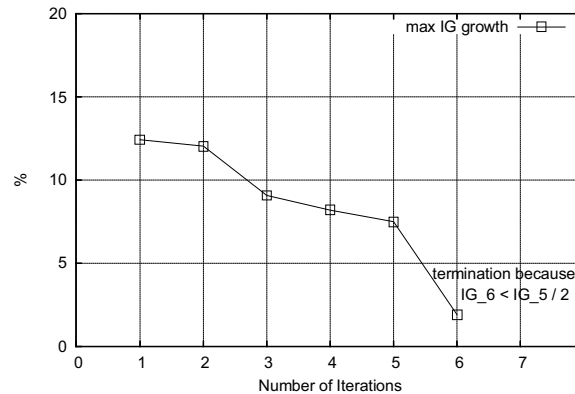

**Figure 3:** Convergence of the maximum IG growth

If necessary you can add domain-dependent aggregation functions to the default primitives above as part of the configuring that potentially better exploit the characteristics of a particular domain. The default set of functions already delivers good results, since it was constructed manually to cover already a broad range of domains and data characteristics. Thus, you can decide for the benefit of high quality manual rule definition for context aggregation by the user or for the savings of a completely automated approach.

## 4 Analysis

### 4.1 Termination

In order to prove the termination behavior of the algorithm, we show by considering the termination condition that for an arbitrary set of given events  $e_1, \dots, e_n$  the algorithm will always stop. The loop continues as soon as the maximum information gain of the newly generated features is higher than half of the maximum of the previous iteration. As the maximum possible IG of any feature is limited by 1 and the information gain values are constantly increasing, the loop iterations are obviously limited. But in most cases not by reaching an IG of 1 for each feature but by terminating the loop since the IG converges much earlier. Figure 3 shows the decrease of the information gain growth with each iteration. Usually the termination condition holds after not more than 5 iterations and the overall increase in accuracy converges.

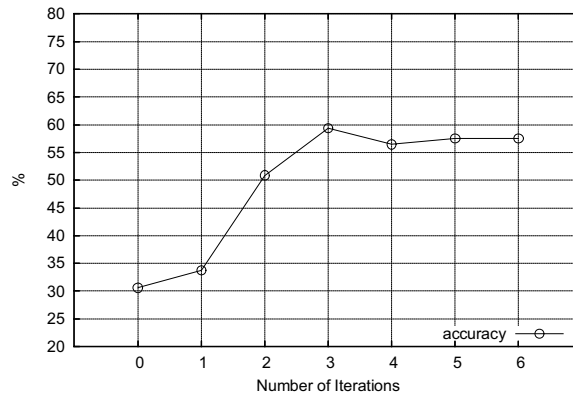

**Figure 4: Boosted Accuracy**

## 4.2 Evaluation

Our evaluation is based on context data of a user study (see Section 2) with  $n = 14$  distinct users, mostly students, and approximately 18 hours of annotated work tasks collected in a domain-specific software engineering scenario. The annotation was added right during the work process by the user itself. In order to measure the improvement of the context aggregation, we apply an  $n$ -folder cross-validation. The training material of each knowledge worker consists of slices of the recorded event stream with the annotated task as a label. Then we select the first folder (first user) for testing the classifier and the rest for training it. Thereafter we calculate the classification performance for this particular data segmentation. This process is repeated by picking the next folder as testing set and the rest as training until each partition is used as testing set. Finally, the averaged performance from the individual data segmentations is used.

The separation of the training folders for each user is necessary in order to really prove that the learned model from the training data is really transferable to the testing user whose training material is not in the particular training set.

Since other researchers report the Naive Bayes classification algorithm to perform well in various domains, we prefer Naive Bayes due to complexity reasons. Figure 4 compares the accuracy values of the prediction algorithm with context aggregation to those without (no. of iterations=0). Obviously, the context aggregation yields to an increased prediction accuracy. We also show the significance of the improvement. Therefore we define the  $H_0$ -hypothesis: The context-aggregated Naive Bayes classification with our collected dataset does \*NOT\* show any improvement over the unmodified feature set. We set the confidence to 99% and apply a t-test for pair wise samples. This test rejects the  $H_0$ -hypothesis which shows some evidence that the context aggregation

significantly increases the accuracy of work task prediction and therefore improves our task-based information system.

It turns out that on the given dataset from our user study logical and frequency functions are preferred by the aggregation algorithm rather than structural and temporal functions. But this might differ on other datasets which incorporate tasks with different feature characteristics.

## 5 Related work

The challenge of automatic user task prediction was addressed in several earlier works. [Shen et al., 2006] and [Stumpf et al., 2005] give promising results for the overall objective of this paper. Horvitz [Horvitz et al., 1998] proposed a Bayesian network approach which supports inference about the user's need. The office assistant prototype, partly deployed in Microsoft Excel, requires explicit modeling of the user and her actions for reasoning about the user's goal. Using a similar event language that offers operators that are a subset of our aggregation functions, they offer means for reasoning from a stream of user actions.

Other projects address work task prediction from a different perspective. Oliver et al. [Oliver et al., 2006] try without any manual training by the user but utilize unsupervised clustering of tasks instead and for that use a string similarity measure on window titles. For unsupervised activity segmentation Brdiczka [Brdiczka et al., 2007] defines a similarity measure based on histograms of event frames.

Technically, our feature aggregation approach partly reminds on decision tree induction [Quinlan, 1986]. By combining features with regard to their entropy, decision trees build hierarchical structures of features joined with the *AND*-operator. Yielding solid classification results decision trees found their way into state of the art machine learning applications.

Since most of the existing solution do not target on our domain-specific problem, we adapt existing ideas and extend them until they match the specific requirements. We differ significantly from other solutions by providing a completely automated approach for aggregating desktop events to higher-level context information used for the current user's work task determination. Additionally, we provide an analysis and an extensive evaluation.

## 6 Summary and Future Work

We propose a context reasoning algorithm that constructs high-level context out of a large number of collected low-level context events. Despite our recommended aggregation functions already yield a significant performance improvement on our dataset for the purpose of user task prediction, we still can extend our general-purpose approach by adding domain-specific potentially more suitable aggregation functions. Still, the quality of the classifier for user task prediction is low for very infrequent classes of tasks.

And the recall of tasks is low as well. However, since the problem of task inference desires high precision and is not so much focused on high recall, we prefer the algorithm not predicting anything at all instead of predicting the wrong class. Nevertheless, we have to face this challenge in our future work.

## References

- [Brdiczka et al., 2007] Brdiczka, O., Crowley, J. L., and Reignier, P. (2007). Learning situation models for providing context-aware services. In Stephanidis, C., editor, *HCI (6)*, volume 4555 of *Lecture Notes in Computer Science*, pages 23–32. Springer.
- [Brezillon, 1999] Brezillon, P. (1999). Context in Artificial Intelligence: I. A survey of the literature. *Computer & Artificial Intelligence*, 18(4):321–340.
- [Grebner et al., 2007] Grebner, O., Riss, U. V., Ong, E., Brunzel, M., Roth-Berghofer, T., and Bernardi, A. (2007). Task management for the nepomuk social semantic desktop (poster). 4th Conference on Professional Knowledge Management - Experiences and Visions -.
- [Horvitz et al., 1998] Horvitz, E., Breese, J., Heckerman, D., Hovel, D., and Rommelse, K. (1998). The Lumiere project: Bayesian user modeling for inferring the goals and needs of software users. In *In Proceedings of the Fourteenth Conference on Uncertainty in Artificial Intelligence*, pages 256–265, Madison, WI.
- [Kessell and Chan, 2006] Kessell, A. and Chan, C. (2006). Castaway: a context-aware task management system. In *CHI '06: CHI '06 extended abstracts on Human factors in computing systems*, pages 941–946, New York, NY, USA. ACM.
- [Kokinov et al., 2007] Kokinov, B. N., Richardson, D. C., Roth-Berghofer, T., and Vieu, L., editors (2007). *Modeling and Using Context, 6th International and Interdisciplinary Conference, CONTEXT 2007, Roskilde, Denmark, August 20-24, 2007, Proceedings*, volume 4635 of *Lecture Notes in Computer Science*. Springer.
- [Lokaiczuk et al., 2007] Lokaiczuk, R., Faatz, A., Beckhaus, A., and Görtz, M. (2007). Enhancing just-in-time e-learning through machine learning on desktop context sensors. In [Kokinov et al., 2007], pages 330–341.
- [Mayer et al., 2005] Mayer, H., Haas, W., Thallinger, G., Lindstaedt, S., and Tochtermann, K. (2005). APOSDLE - Advanced Process-oriented Self-directed Learning Environment. Poster Presented on the 2nd European Workshop on the Integration of Knowledge, Semantic and Digital Media Technologies.
- [Mitchell, 1997] Mitchell, T. M. (1997). *Machine Learning*. McGraw-Hill Higher Education.
- [Oliver et al., 2006] Oliver, N., Smith, G., Thakkar, C., and Surendran, A. C. (2006). Swish: semantic analysis of window titles and switching history. *Proceedings of IUI '06*, :194–201.
- [Quinlan, 1986] Quinlan, J. R. (1986). Induction of Decision Trees. *Machine Learning*, 1(1):81–106.
- [Shen et al., 2006] Shen, J., Li, L., Dietterich, T. G., and Herlocker, J. L. (2006). A hybrid learning system for recognizing user tasks from desktop activities and email messages. In *IUI '06: Proceedings of the 11th international conference on Intelligent user interfaces*, pages 86–92, New York, NY, USA. ACM Press.
- [Stumpf et al., 2005] Stumpf, S., Bao, X., Dragunov, A., Dietterich, T. G., Herlocker, J., Johnsrude, K., Li, L., and Shen, J. (2005). Predicting User Tasks: I Know What You're Doing. *20th National Conference on Artificial Intelligence (AAAI-05), Workshop on Human Comprehensible Machine Learning*, .
- [Zaïane, 2002] Zaïane, O. R. (2002). Building a recommender agent for e-learning systems. In *ICCE '02: Proceedings of the International Conference on Computers in Education*, page 55, Washington, DC, USA. IEEE Computer Society.
- [Zimmermann et al., 2007] Zimmermann, A., Lorenz, A., and Oppermann, R. (2007). An operational definition of context. In [Kokinov et al., 2007], pages 558–571.



# A Model for Context-Sensitive Transfer of Expertise

**Bernhard Mayr**

(rumpfhuber.cc, Scharten, Austria  
bernhardmayr@gmx.net)

**Rainer Born**

(Institute of Philosophy of Science, Johannes Kepler University, Linz, Austria  
rainer.born@jku.at)

**Abstract:** This paper introduces the LIR-Schema, a framework to model knowledge flows within a company based on model-theory. Competence management is integrated in this framework as a tool for modelling the contexts of sender and receiver of expertise. The main target of this framework is to reduce the knowledge gap between experts and laymen within the company.

**Keywords:** Competence-management, transfer of expertise, knowledge-transfer, LIR-Schema

**Categories:** M.4

## 1 Introduction

This paper discusses the topic of sharing expertise within a company. It will give you an idea, why it is difficult to share expertise and sketches a model that helps to ensure that expertise can be transferred in the company. The authors of the paper work in the field of knowledge management and have already conducted several structured interviews with managers responsible for knowledge transfer processes and/or human resources in different companies in Austria ranging von 200 to 1000 employees. These interviews indicated a major problem with designing the process of expertise transfer. The interviewees located a loss of quality of expertise during the transfer-process.

The authors of the paper derived a need of frameworks for context-sensitive knowledge transfer within companies. Probably the LIR-Schema enriched with competence management can outline such a framework. In what follows the authors first describe the LIR-Schema and the some required basics of competence management. Afterwards these two buckets are combined and the benefits of this integration are illustrated.

The approach is based on a model of knowledge transfer and representation that itself is based on model-theory. This is the LIR-Schema (*Language-Information-Reality*) which is illustrated in Figure 1 [Born 1987; Born 2000b; Born 2000a; Born and Danielczyk 2007]. The initial point of the LIR-Schema is an analysis of language in relation to information and reality but can be extended to a general framework for the analysis of correlation of representation, knowledge and world.

The LIR Schema contains four roles in the knowledge transfer process which are embedded in the two dimensions representation and reality. Furthermore you have to differentiate between the left side (structures) and the right side (processes). The left

side shows the static and explanatory side whereas the right side shows the dynamical and operative elements.

The main objective is to get a better understanding of the generating, creating and transferring of knowledge especially the transfer of expertise with the help of multi-component semantics according to the philosophy of science see [Born 2000b].

The main quadrants show the different roles that are involved in the process of transferring knowledge. There are the expert's role (E), the layman's role (F), the calculus (C) and the meta-knowledge (M).

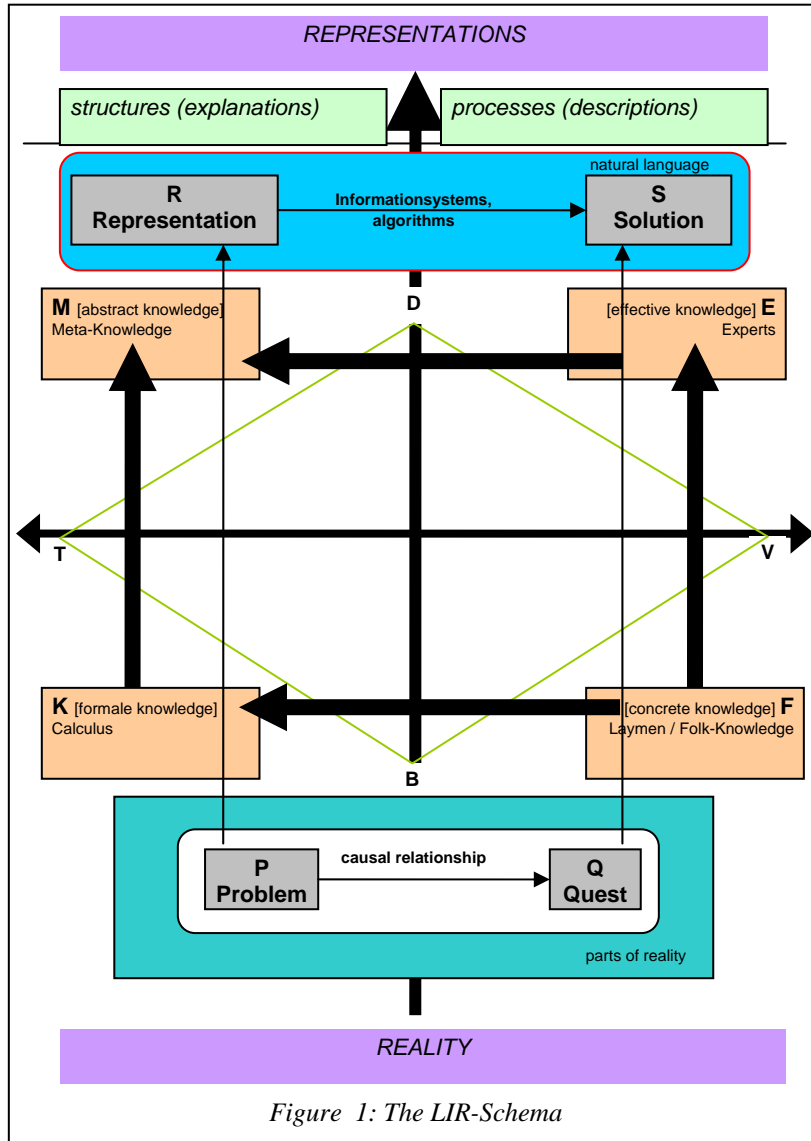

Figure 1: The LIR-Schema

If you try to illustrate the procedure of reproducing a solution of a special problem in the real world (the transition from the Problem P to Quest Q in the LIR-Schema) you have to make explicit the components which represent the background-knowledge of the individuals who are involved in the process of sharing knowledge.

An important aspect is the splitting of the total area in a part above the middle and one below the middle because in the top part, there is a logical deduction whereas in the bottom part there is a temporal deduction of the solution.

The LIR-Schema addresses the main-problems of knowledge management systems, that act in a way that McElroy and Firestone capture with the term *first generation knowledge management* [Firestone 2001a; Firestone 2003; Firestone and McElroy 2003a; Firestone and McElroy 2003b; McElroy 2003]. First generation knowledge management means that the experts' knowledge (the E-role in the LIR-Schema) is just codified, digitalized and stored in databases. In terms of the LIR-Schema the Experts document their knowledge. This is stored in a database-system. The knowledge is transferred from E to C. C now acts as a kind of experts system for the laymen (F). The laymen just act according to the given rules in C, yet they do not understand the deep rooted sense in these rules. First generation knowledge management was misused for eliminating the experts (many thought, the whole experts knowledge is stored in the rules in C). Yet in this state the system is stuck. Every time when there is a case that doesn't fit into the given rules it is considered as defective work because the laymen do not have the required background knowledge to interpret the case and generate an innovative solution. According to the LIR-Schema there are only the roles C and F involved. This way knowledge transfer work like an assembly line. Everything that doesn't stick to the rule is considered as defective work. The only Mantra is: never stop the assembly line. The work of Deming at Toyota showed that the assembly line should be stopped every a time a failure occurs and the root of the failure should be retrieved to improve quality.

Firestone and McElroy reclaim that this kind of knowledge management is just another information management concept because it deals with information and not with knowledge. The LIR-Schema shows that individuals in the role of experts produce a different set of solutions using the formal knowledge from the Calculus (C) than the individuals in the role of laymen would do. These two sets are equivalent in an average realm, yet problems arise in the periphery. These peripheral spots are the origins of new knowledge and innovative energy. Therefore we have to bestow consideration upon this peripheral spots.

## 2 Problems with the transfer of expertise

The main target of knowledge management within a company is, wide spreading the experts' knowledge within the company. Ideally the laymen have the same knowledge as the experts. Nevertheless in reality a gap arises between the knowledge of the experts and the layman. (*Mind that "expert" and "layman" are roles in the knowledge transfer process. The same individual within the company can occupy different roles in different knowledge processes.*) This knowledge gap is illustrated by

the distance between the experts' role (E - Experts) and the laymen's role (F – Folk-Knowledge) in the LIR-Schema (see Figure 2)

This knowledge gap exists for different reasons. One of them is the difficulty of transferring knowledge, due a different background or context of the participants. Usually the way of solving a problem is codified in a special formalized way. Yet the person who documents the case only documents, what he or she thinks is important. These important facts are those that were important because of the context of the documenting person. There may be aspects that would be important to another reader with a different background, but they were not documented. In this way the documentation is less worth to the reader. To minimize these problems the people in the role of experts and the people in the role of laymen should communicate more intense. Nonetheless the communication is the most difficult part of the knowledge transfer process. For example nurses have a lot of practical knowledge in dealing with patients and in diagnosing kinds of illnesses whereas doctors have expert knowledge and knowledge in the theory of illnesses. In the sense of knowledge and expertise transfer the two parties should communicate and exchange knowledge for better mutual understanding an improving the treatment of patients. Yet there are different cognitive and motivational factors that affect the willingness of knowledge-sharing. Hinds and Pfeffer argue that *“there are deep-rooted cognitive and motivational limitations that interfere with people’s ability to share their expertise.”* (see [Hinds and Pfeffer 2002]) In the case of nurses and doctors there are different barriers. One of them is a motivational or social factor because doctors usually have a higher social reputation than nurses due to their academic degree and longer studies. For removing this barrier different training from the field of soft skills could improve the situation. Another barrier is a contextual. Generalizing nurses are practitioners (laymen in the sense of the LIR-Schema). Their problem approach is patient-oriented. Generalizing doctors are experts. Their problem approach is coined from their studies of medicine, they are Science-oriented. The gap between these two groups also arises because of the different contexts. Another example for the impact of different contexts could be the use of context-specific vocabulary. If you are able to model the context of the people participating in the process of knowledge sharing and generating, it’s easier for them to understand and interpret the knowledge of the other party.

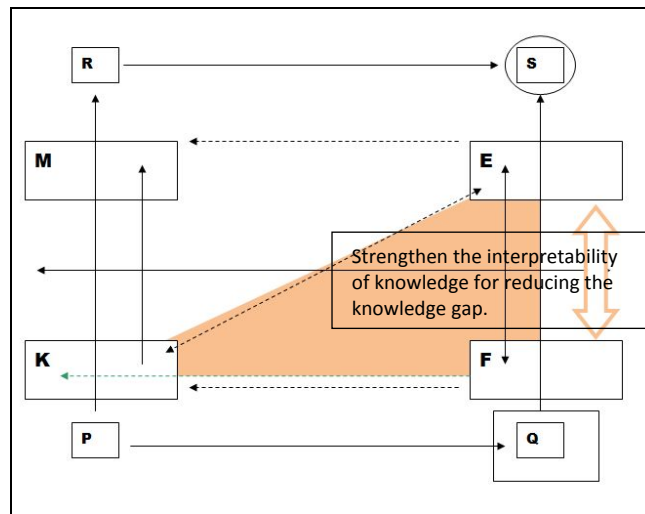

Figure 2: The knowledge Gap

Generally speaking, the main reasons for the knowledge gap are limitations in the transfer of knowledge. These limitations could be minimized by establishing a common ground between the expert and the layman respectively between the sender and the receiver of the expertise.

### 3 Striving for a solution

Neglecting the fact, that this model of the transfer of expertise is a generic model that's not bound to a specific software system the use within software can be promising. If a knowledge management software tool should be successful, it must be capable of minimizing the knowledge gap within the company and help to simplify the transfer of expertise. To do so, the tool must consider the context of the sender and the context of the receiver – this is what the model does.

This context is summarized in M (the Meta-Knowledge) within the LIR-Schema. The Meta-Knowledge describes what makes the experts successful. This description contains the context in which the knowledge was created and the background knowledge of the participants. The main challenge is to find a way to model such a context. One approach could be the use of the methods of competence management to model the individual's background. For this reason the following section covers some basics of competence management and how it's integrated into the LIR-Schema.

### 4 Competence Management

This paper shouldn't give a deep insight in the methods of competence assessment. The reader interested in the topic of competence assessment is referred to [Bergenhengouwen, Horn ten et al. 1996; Bellmann 2002; Erpenbeck and von

Rosenstiel 2003; Rosenstiel, Pieler et al. 2004; Zelewski, Alan et al. 2005; Bergmann and Daub 2006; Jochmann and Gechter 2007] for a deeper insight in the assessment of competences.

To give a short introduction in the field of competence assessment we have to distinguish between self-assessment and external-assessment of competences. Self-assessment means that individuals rate their competences by themselves whereas external-assessment means that the competences are rated by another person (mostly the superior of the individual person). Both practices have different advantages and disadvantages. Therefore the methods should be combined to get a good understanding of the competences of the individual.

With the help of the assessed competencies it's possible to model a network of competences for each person within the organization (it's also possible to do this for external persons – e. g. customers, suppliers, etc). These individual competences are aggregated to an individual competence-profile.

This competence-profile forms a strengthened Meta-Knowledge about the contexts of the individuals participating in the knowledge transfer process. With this stronger M it is possible to enrich and represent expertise with context. This means the context of the sender and the receiver of expertise can be encoded into the problem-solving algorithm. (The transition from R to S in the LIR-Schema)

So especially information and communication systems using a strong Meta-Knowledge M to enrich expertise with context are capable of presenting meaningful knowledge to the receiver. The knowledge receiver can interpret the knowledge in an easier way. This makes systems able of sense making [Weick 2001] for the interacting individuals. Now individuals are able to interpret expertise in an easier way. This supports the transfer of expertise. This way of sense-making should help enterprise to minimize the knowledge gap and support the dialogue between the roles Experts and Folk-Knowledge within the LIR-Schema.

The integration of methods of competence management into the LIR-Schema enriches the possibilities of transferring expertise by adding a component that is able to represent the context of the sender and the context of the receiver. This representation can be processed automatically by information technology. So the integration enables information technology to represent expertise according to the specific needs of the users.

## 5 Future work

There has to be done future research work about the way, knowledge can automatically be adapted to different contexts and this functionality can be successfully used in information and communication systems.

Therefore, further research should be conducted in the field of context-sensitive knowledge transfer. Case studies should show how the framework of sharing expertise and knowledge that was presented in this paper can be best adapted to the requirements of practice and how these theories can be combined with existing theories of representing knowledge in an adequate way.

## References

- [Bellmann, K. 2002] Bellmann, K., Ed. *Aktionsfelder Des Kompetenz-Managements - Ergebnisse Des 2. Symposiums Strategisches Kompetenz-Management.*; Wiesbaden; Deutscher Universitäts-Verlag GWV Fachverlage GmbH; 3824475804.
- [Bergenhengouwen, G. J., H. F. K. Horn ten, et al. 1996] Bergenhengouwen, G. J., H. F. K. Horn ten, et al.; "Competence Development - a Challenge for Hrm Professionals: Core Competences of Organizations as Guidelines for the Development of Employees." *Journal of European Industrial Training*; 20(9): 29-35.
- [Bergmann, G. and J. Daub 2006] Bergmann, G. and J. Daub; *Systemisches Innovations Und Kompetenzmanagement: Grundlagen - Prozesse - Perspektiven.* Wiesbaden; Betriebswirtschaftlicher Verlag Dr. Th. Gabler; 103834901431.
- [Biesalski, E. 2004] Biesalski, E.; "Ontologien Als Bindeglied Bei Der Personalentwicklung." Source: <http://www.ernst-biesalski.de/> [last visited: 2008-06-08]
- [Born, R. 1987] Born, R., Ed. *Artificial Intelligence: The Case Against*; London / Sydney; (paperback 1988, reprinted 1989); St. Martin's Press; 0312004397.
- [Born, R. 2000a] Born, R.; "Prometheus in Der Hölle: Chancen Zur Verbindung Von Technik Und Kunst Oder Chancen Und Nutzen Einer Globalen Informationsvernetzung."
- [Born, R. 2000b] Born, R.; "Was Soll Und Was Kann Es Bedeuten, Von Wissen Zu Reden? (Vom Nach-Denken Über Wissen Zum Vor-Aus-Denken Von Wissen)." Source: <http://sowi.iwp.uni-linz.ac.at/Dialog/Mitarbeiter/BORN/wm2k0917/WM280700.html> [last visited: 2008-06-18]
- [Born, R. and S. Danielczyk 2007] Born, R. and S. Danielczyk; "Kreativität – Europas Letzter Wettbewerbsvorteil?" Source: [http://www.iwp.jku.at/born/mpwfst/07/0711\\_Wettbewerbsvorteil.pdf](http://www.iwp.jku.at/born/mpwfst/07/0711_Wettbewerbsvorteil.pdf) [last visited: 2008-06-08]
- [Erpenbeck, J. and L. von Rosenstiel 2003] Erpenbeck, J. and L. von Rosenstiel, Eds.; *Handbuch Der Kompetenzmessung - Erkennen, Verstehen Und Bewerten Von Kompetenzen in Der Betrieblichen, Pädagogischen Und Psychologischen Praxis*; Stuttgart; Schäffer-Pöschl; 3-7910-2106-0.
- [Firestone, J. M. 2001a] Firestone, J. M.; "Key Issues in Knowledge Management." *Knowledge and Innovation: Journal of the KMCI 1*; 3: 8-38.
- [Firestone, J. M. 2001b] Firestone, J. M.; "Knowledge Management Process Methodology: An Overview." *Knowledge and Innovation: Journal of the KMCI 1*; 2: 54-90.
- [Firestone, J. M. 2003] Firestone, J. M.; *Enterprise Information Portals and Knowledge Management*; Butterworth Heinemann; 0750674741.
- [Firestone, J. M. and M. W. McElroy 2003a] Firestone, J. M. and M. W. McElroy; *Key Issues in the New Knowledge Management.* Burlington, MA; Elsevier Science; 0-7506-7655-8.
- [Firestone, J. M. and M. W. McElroy 2003b] Firestone, J. M. and M. W. McElroy; *The Open Enterprise - Building Business Architectures for Openness and Sustainable Innovation.* Vermont; KMCI Online Press.
- [Hinds, P. J. and J. Pfeffer 2002] Hinds, P. J. and J. Pfeffer (2002); "Why Organizations Don't Know What They Know": Cognitive and Motivational Factors Affecting the Transfer of Expertise." from <http://gobi.stanford.edu/ResearchPapers/Library/RP1697.pdf>.

[Jochmann, W. and S. Gechter 2007] Jochmann, W. and S. Gechter, Eds.; *Strategisches Kompetenzmanagement*; Berlin/Heidelberg; Springer-Verlag; 103540279660.

[McElroy, M. W. 2003] McElroy, M. W.; *The New Knowledge Management: Complexity, Learning, and Sustainable Innovations*. Boston, MA; KMCI Press / Butterworth-Heinemann; 0750676086.

[Prahalad, C. K. and G. Hamle 1990] Prahalad, C. K. and G. Hamle; The Core Competence of the Corporation. *Harvard Business Review*.

[Rosenstiel, L. v. H., D. Pieler, et al. 2004] Rosenstiel, L. v. H., D. Pieler, et al., Eds.; *Strategisches Kompetenzmanagement - Von Der Strategie Zur Kompetenzentwicklung in Der Praxis*; Gabler Verlag; 3-409-12597-3

[Weick, K. E. 2001] Weick, K. E.; *Sensemaking in Organizations (Foundations for Organizational Science)*; Blackwell Publishing Ltd.

[Zelewski, S., Y. Alan, et al. 2005] Zelewski, S., Y. Alan, et al., Eds.; *Ontologiebasierte Kompetenzmanagementsysteme - Grundlagen, Konzepte, Anwendungen*; Berlin; Logos Verlag; 3-8325-0617-9.



# **Collaboration Patterns for Knowledge Sharing and Integration in Second Life: A Classification of Virtual 3D Group Interaction Scripts**

**Andreas Schmeil**

(University of Lugano, Switzerland  
andreas.schmeil@gmail.com)

**Martin J. Eppler**

(University of Lugano, Switzerland  
epplerm@gmail.com)

**Abstract:** In this paper we propose a classification and systematic description structure based on the pattern paradigm for interaction scripts in Second Life that aim at facilitating knowledge sharing and knowledge integration in groups. We present eight examples of such interactions, a description structure to formalize them, and classify them into four classes according to their design scope and added value. Based on this classification we distinguish among sophisticated 3D collaboration patterns, seamless patterns, decorative patterns, and pseudo patterns.

**Keywords:** Interaction, Knowledge Visualization, Patterns, Second Life, Knowledge Sharing, Knowledge Integration, Collaboration, Collaborative Virtual Environments

**Categories:** H.4.3, H.5.3, J.5, M.0

## **1 Introduction**

Modern organizations have realized that information and knowledge is essential for their success. The increasing use of electronic information systems in work processes is the foundation of the development of the concept of organization memory and the driving motor in the research field of knowledge management.

Tomek states that the information capturing part of a knowledge management system should include a Collaborative Virtual Environment (CVE) [Tomek, 01]. He defines a CVE as a software environment that creates a configurable universe which emulates a number of serviceable aspects of physical reality, such as the concept of space, movable objects, navigation, and communication between (representations of) humans. The most relevant of the several reasons Tomek gives for his claim are:

- the emulation of physical topology as a natural metaphor, a prerequisite for successful groupware
- CVE allow for organizing both people and information spatially
- awareness of co-workers, usage policies for tools and objects is enhanced
- allocated space can be separated to allow privacy and group restrictions
- computer-mediated communication between disjoint places provides a good basis for recording in context (as all communication can be logged instantly)

Collaborative Virtual Environments can thus enhance sharing and integration of knowledge. We agree in this point and further believe that the use of a three-dimensional CVE can upgrade current knowledge management even more substantially, even in situations that go beyond visualizing data or reviewing spatial models in applications like architecture and design. Our systematic description and classification of group interaction scripts in 3D collaborative environments aims to help facilitate and enhance team collaboration and knowledge management by providing reusable patterns that leverage the ample possibilities only three-dimensional virtual environments offer.

So far it is unclear what enhancements are needed to make a CVE a really good environment for serious distributed collaborations [Bainbridge, 07]. Among other benefits, a classification like the one we propose in this paper could form a first step in the process of formalizing collaboration in virtual environments by providing an overview of so far implemented patterns, could help in the research regarding theories that underlie 3D interaction for collaboration, and could initiate a collection of reusable best practice patterns and templates.

The remainder of this paper starts with giving reasons why 3D collaborative environments in general and the online virtual world Second Life in particular can improve collaboration and knowledge sharing. In chapter 3 we then first discuss previous work that relates to our proposal of a formalization of 3D collaboration patterns. In succession to that we introduce our systematic description structure, show it applied on two example key patterns, and propose our classification. Chapter 4 presents conclusions we could draw, suggest implications of the presented work, and outline some directions of our future work.

## 2 Why Second Life?

The vague definition of CVE in a general sense comprises all systems spanning from text-based environments [Hayes, 98] through environments with simple two-dimensional graphical representations [Vitero, 08] to systems based on Virtual Reality (VR). As mentioned in stating our motivation, our research focuses on the latter, regarding only three-dimensional graphical CVE that are rich in representation and support embodied avatars and 3D objects in spatial relation to each other. Some major advantages in comparison to the former types of CVE are given in the following. After that, characteristics of Second Life that distinguish this online virtual world from other 3D collaborative virtual environments are presented.

### 2.1 3D Collaborative Virtual Environments

Compared to text-based and two-dimensional ‘flat’ graphical CVE, an environment fully based on three dimensions can enhance the functionality in a number of respects. Most importantly, 3D environments provide ways to experience and view information that is *dynamic and interactive* [Krange, 02]. A more accurate *approximation of physical reality* can be provided, which can ease first access to the system and improve overall usability. In the same sense, a “feeling of immersion, a perceptual and psychological sense of *being in the digital environment*” is evoked [McLellan, 96]. Also the feeling of *presence* is enhanced, by the sense of orientation and position

in space. People and information can be *organized* in a more natural way in three dimensions, also making available more real space instead of small corners on flat screens. McLellan states that three-dimensional CVE are proclaimed to be appropriate for model building and problem solving [McLellan, 96].

Casanueva et al. presented experiment results showing that the *awareness* of collaborators and their actions can be significantly enhanced by more realistic representations of persons [Casanueva, 01]. Furthermore, *usage policies* for tools and objects can be illustrated more clearly and in a more natural way employing the theory of affordances [Norman, 88]. And finally, the level of *privacy* of allocated spaces is continuously adjustable in a natural way (cmp. the office design metaphor: open office vs. combo office vs. private office).

A disadvantage of three-dimensional virtual environments mentioned in the literature describes the opinion that 3D models are more difficult to use than 2D data or text and could thus distract a user from communication. We take this issue into account by regarding the design scope of the particular collaboration patterns in our classification. This is explained in more detail in chapter 4. A differentiation in defining CVE is made concerning the accessibility of 3D virtual environments. Immersive collaborative VR systems are in most cases locally installed, while some desktop-based three-dimensional CVE are online virtual worlds with persistent world states, and are thus accessible virtually around the clock (with regards to system downtime). The fact that all data is being held online is an important distinction to other CVE, yet the acronym MUVE has been established for these *online* Multi-User Virtual Environments.

For the said reasons also we believe that 3D collaborative environments help make sense of complex data, can help develop a common understanding in a collaborative mind set and engage people through appealing and memorable experiences. The latter can lead to an increased involvement, can focus attention of the participants, and provide a good basis for creativity.

## 2.2 Relevant Characteristics of Second Life

Second Life is an online Multi-User Virtual Environment (MUVE), i.e. a special type of CVE [Second Life, 08]. Using a viewer software, everyone can access this virtual world, from anywhere, at any time. The status of the world is persistent; no data is lost, nor has massive data to be up- or downloaded at login. Users are represented by extremely customizable avatars that have a unique name and can resemble strong own identities. Targeting businesses and entrepreneurs, Second Life is often advertized as “a place where there are no real-world manufacturing or service costs and few barriers to what’s possible”. Second Life was launched in 2003. After a massive hype in 2007, the statistics of April 2008 state that over 13 million users had registered in total, and about 1 million users had signed in during the preceding 60 days [SL Stats, 08]. Characteristics of SL relevant for knowledge management and collaboration are:

- content is produced by residents of the world; developers provide powerful tools designed to be used by everyone [Ondrejka, 08]
- in-world spaces are thus easily reconfigurable and extendable at any time
- avatars can present valuable identity information solely by appearance

- group and private chat functionality, as well as object sharing provide inherent collaboration possibilities

### 3 Collaboration Patterns for Knowledge Management

A pattern is a description of a known solution to a specific type of problem [Gottesdiener, 01]. The theory of patterns, originally developed for architecture [Alexander, 99], but in practice more commonly used in software development [Gamma, 95], can be usefully applied to the domain of collaboration.

Collaboration patterns can be understood in terms of how users act in dialogues and in the usage of artifacts [Krange, 02]. Gottesdiener defines them as techniques, behaviors, and activities for people who share a common goal of working together in a group [Gottesdiener, 01]. For our proposed formalization and classification of different collaboration situations through the use of patterns, we use this definition and extend it by the requirements for the creation of the virtual experience. This is explained in more detail in section 3.2. We believe that the pattern concept offers the right type of granularity and reproducibility to capture and *envison* collaboration possibilities in Second Life. This seems feasible as the pattern approach has been applied to similar endeavours such as e-learning, web design, or programming.

#### 3.1 Related Work

The MG Taylor Corporation developed a modeling language, introducing patterns for collaboration and organization in enterprises [MGTaylor, 96]. Whyte et al. investigate visual practices – practices around visual materials, i.e. artifacts that embody the current status of a design or act as mediating devices to develop understanding [Whyte, 07]. Visual materials play a significant role in knowledge practices within organizations. Krange investigated collaboration patterns for learning in Second Life, but only to a certain extent [Krange, 02]. Since that research strongly focused on learning, i.e. on knowledge construction, the analysis of the interrelations between actors, especially vocal interaction were investigated.

#### 3.2 Description of Collaboration Patterns

In the following we introduce a systematic description structure which we developed as a means to formalize collaboration patterns in 3D virtual environments. We applied this description structure on the various patterns that emerged in our research in Second Life. Due to lack of space, this paper only presents the descriptions of two of the key collaboration patterns of the eight we found and classified in the end. Figure 1 shows two screenshots of within Second Life: a virtual meeting (a) and a virtual design studio (b). The latter facilitates the collaborative design and implementation of functionality of a door with a security panel – rapid prototyping at its best: door and panel can be tested already during the creation and design process. Table 1 shows our description structure, applied on the two shown collaboration patterns. We describe such a pattern among other criteria through its usage situation, i.e. the context in which the virtual environment is used, the aim of the usage, the level of intensity of the participants' interaction as well as common actions of the avatars, what artifacts

are required in general, risks or caveats of the pattern and the design scope: the amount of effort required to develop the environment for the collaboration pattern.



Figure 1: Screenshots of (a) a Virtual Meeting and (b) a Virtual Design Studio in Second Life ((b) from [Bainbridge, 07])

Pattern Name	Virtual Meeting	Virtual Design Studio
Usage Situations	project meeting, team meeting	product development/design, architectural design
Objective	knowledge transfer and decision making	design of a physical (or virtual) object
# Participants	< 15	< 5
Interaction Intensity	low to medium	high
Typical Duration	up to 1 hour	up to 4 hours
Required Artifacts	places to sit, information displays	designing tools, sketching tools, plans
Avatar Actions	chatting, showing	modeling, designing, sketching
Risks	not making use of 3D features	design influenced by limited functionality of design studio
Design Scope	medium: room design and projections	very high: design tools, sketching tools; interaction design

Table 1: Description structure for collaboration patterns in Second Life, applied to two example patterns

### 3.3 A Classification of Collaboration Patterns

We propose a classification of collaboration patterns in 3D virtual environments by arranging them in two dimensions according to their design scope and their 3D added value. By design scope we mean the amount of effort that is necessary to stage the particular collaboration pattern; 3D added value can be seen as a compound measurement comprising efficiency, cost, and quality of the collaboration and its outcomes. We chose these dimensions to put into relation the effort of designing a virtual 3D experience with the outcome gained from it. The design scope could be gauged in measuring the time and manpower required to prepare the collaboration setting and functionality, while the compound axis of 3D added value is more complex to measure. In this early stage of research, both measurements are

operationalized qualitatively. Choosing these criteria allows us to distinguish real value added collaboration patterns from merely cosmetic ones. Our research scope will focus on patterns that can be deployed in organizational contexts. The principal research methods used are participant observation in Second Life and subsequent classification and documentation. The classification showing the first eight emergent patterns is shown in figure 2. Elliptic elements in the figure make clear that there can be different occurrences of one pattern.

To exemplify the two axes, the upper extreme in added value would be a collaboration pattern that is time-efficient (e.g. product modeling and reviewing/testing at the same time), saves costs (e.g. in physical prototype production) and can result in a higher quality (by e.g. seeing a product in its designated usage context), like the *Virtual Design Studio* pattern. The design scope in this case is high, due to the necessary a-priori implementation of design and modeling functionalities and tools. The *Virtual Workplace* pattern describes the mirroring of ongoing work and workplaces in the real world into the CVE, e.g. casting the computer screens of employees while they are working (called ‘screencasting’) onto walls or other in-world projections. Co-workers can thus get an overview of what everybody is currently working on by wandering through the virtual workplace and can give help in particular cases. Another example pattern of collaborative work is *Knowledge Map Co-Construction*. Collaborators construct and modify a knowledge map in the CVE. The 3D added value here is based around collaborative interaction as well as viewing and editing multiple designs of a knowledge map in context. Obviously, many of the classified patterns share the fact that putting more design effort into the collaboration pattern leads to more added value; this can be seen by the orientation of some ellipses from the left-lower corner to the right-upper corner.

A *Learning Trail* is a means for providing stepwise knowledge acquisition by positioning objects of any complexity as learning content along a trail in the virtual world. People share and perceive common interests implicitly by meeting in front of the same objects. This concept of premeditated serendipity is also applied in the *Knowledge Fair* pattern, which differs from the learning trail in terms of time scheduling. A knowledge fair is an event while a learning trail is more of a persistent exposition. The two patterns are different also in terms of complexity of the presented objects, as at knowledge fairs mostly simple elements like posters and video/slideshow presentations are on display. We called this class, which comprises 3D experiences as a natural solution to problems, “Quick Wins” to emphasize the great 3D added value compared to a rather low designing effort required.

Descending the axis of 3D added value, two patterns emerged that use the 3D experience as a means for motivating collaborators to participate and for higher engagement; we called them “decorative patterns”. The *Virtual Meeting* pattern in the simplest form merely constitutes the staging of a meeting room where collaborators can chat and talk to each other and hold presentations. Also in this case, as illustrated in figure 2, adding more functionality to get a higher added value comes with an increase in implementation effort. The *Group Configuration* pattern comprises all group activities that follow the “voting by feet” principle, i.e. using localization, navigation and other spatial cues as an indication of personal preference. For example, a group of people can divide into disjoint subgroups for voting or to answer a question; the results and tendencies are visualized.

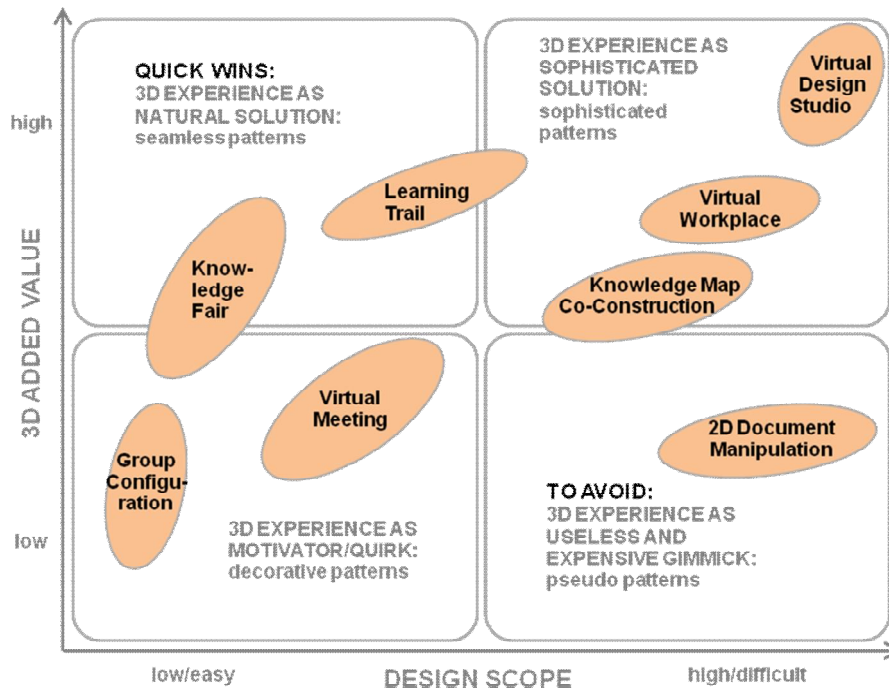

Figure 2: A classification of collaboration patterns by design scope and 3D added value

An example of a 3D experience as a useless and expensive gimmick we have come across is the creation and editing of a Powerpoint presentation on a Second Life collaborative design screen. In the classification this is represented by the pseudo pattern *2D Document Manipulation*. The complex user interface of enabling several people to work on a 2D document together could be done easier and more convenient in a 2D collaborative environment, for example in Google Docs [GoogleDocs, 08].

#### 4 Conclusions and Future Work

The presented classification should sensitize designers and users to the fact that not all collaboration scenarios envisioned for use in Second Life may generate the added value the amount of effort put in might promise. The classification can furthermore be used to empirically test which features lead to high-value patterns and which quadrant patterns are used in which constellations or for which motives. As such the current classification is subject to on-going revisions. It is early work, scientific proof is still to be developed. Nevertheless already its current form helps researchers, designers, and users to assess a 3D collaboration setting in terms of its scope and benefits.

Further steps will include the definition of additional patterns, different classification approaches, and also the development of guidelines for the creation of effective experiences for virtual environments. Future work could furthermore include

an experimental comparison of collaboration tasks in three-dimensional CVE against corresponding tasks in text-based CVE and real-life collaboration, which could be evaluated by performance. Furthermore, to go deeper into collaboration, investigating the question of which theories help to explain 3D interaction for collaboration would be very interesting; for example, the actor-network theory, Gibson's theory of affordances, and the cognitive scaffolding theory. Our research is focusing on Second Life right now because of its availability, the great opportunity to conduct research due to a huge number of events and participants, and its convenience of use, but we are not excluding other virtual worlds and collaborative online environments.

## References

- [Alexander, 99] Alexander, C.: A Pattern Language. IEEE Transactions on Professional Communication, vol. 42, no. 2. 1999.
- [Bainbridge, 07] Bainbridge, W. S.: The Scientific Research Potential of Virtual Worlds. Science, vol. 317, no. 5837. July 2007.
- [Casanueva, 01] Casanueva, J., Blake, E.: The Effects of Group Collaboration on Presence in a Collaborative Virtual Environment. EGVE'00 – 6th Eurographics Workshop on Virtual Environments, June 2000.
- [Gamma, 95] Gamma, E., Helm, R., Johnson, R., Vlissides, J.: Design patterns: elements of reusable object-oriented software. Addison-Wesley Longman Publishing Co., Inc. Boston, MA, USA, 1995.
- [GoogleDocs, 08] Google Docs, 2008, <http://docs.google.com/>
- [Gottesdiener, 01] Gottesdiener, E.: Decide How to Decide: A Collaboration Pattern. Software Development Magazine, vol. 9, no. 1, 2001.
- [Krange, 02] Krange, I., Fjuk, A., Larsen, A., Ludvigsen, S.: Describing construction of knowledge through identification of collaboration patterns in 3D learning environments. Proceedings of CSCL 2002, Boulder, Colorado, USA, January 7-11, 2002.
- [McLellan, 96] McLellan, H.: Virtual Realities. Handbook of Research for Educational Communications and Technology, New York, NY: Macmillan, 1996.
- [MGTaylor, 96] MG Taylor Corporation, 2008, <http://www.mgtaylor.com/>
- [Norman, 88] Norman, D.: The Design of Everyday Things. New York: Basic Books, 1988.
- [Ondrejka, 08] Ondrejka, C.: Education Unleashed: Participatory Culture, Education, and Innovation in Second Life. The Ecology of Games: Connecting Youth, Games, and Learning, The John D. and Catherine T. MacArthur Foundation Series on Digital Media and Learning. Cambridge, MA: The MIT Press, 2008.
- [Second Life, 08] Second Life, 2008, <http://www.secondlife.com/>
- [SL Stats, 08] Second Life Statistics, 2008, [http://secondlife.com/whatis/economy\\_stats.php](http://secondlife.com/whatis/economy_stats.php)
- [Tomek, 01] Tomek, I.: Knowledge Management and Collaborative Virtual Environments. Journal of Universal Computer Science, vol. 7, no. 6. 2001.
- [Vitero, 08] Vitero, 2008, <http://www.vitero.de/>
- [Whyte, 07] Whyte, J.K., Ewenstein, B., Hales, M., Tidd, J.: Visual practices and the objects used in design. Building Research and Information, vol. 35, no. 1, 2007.



# The Leap to Knowledge Management for Universities in Developing Economies

**Ciprian Cucu**

("1 Decembrie" University, Alba-Iulia, Romania  
cucu.ciprian@gmail.com)

**Mircea Rîșteiu**

("1 Decembrie" University, Alba-Iulia, Romania  
mircearisteiu@yahoo.com)

**Abstract:** Although collaboration is widely accepted as the most efficient method for creating value some important barriers of knowledge sharing arise leading to the creation of non-collaborative environments. Especially in developing countries, universities have to face new challenges that rise from shifts in the knowledge production paradigms and from frequent changes in policies. Considering these particularities, we believe that some measures have to be taken to ensure a leap to knowledge sharing, a leap over usual knowledge sharing barriers that arise on traditional approaches to knowledge management implementations.

**Keywords:** knowledge sharing, non-collaborative environments, universities

**Categories:** H.1

## 1 Introduction

Collaboration is a process, where two or more people who share a common goal work together, share knowledge, exchange ideas and build a unitary result. Other definitions mention, beside the aspect of idea exchange and knowledge sharing the need to share "complementary skills interacting to create an understanding that none had previously possessed or could have come to on their own". [Schrage, 1995]

Going further into the definition of the concept, we can find the three levels of collaboration [Schrage, 1990].

- Level 1: At a basic level, individuals operate independently and interact to accommodate their own specific needs passing documents back and forth and sharing information, but not as part of a working group or team.
- Level 2: At the next level, a group of individuals exchange information as part of a community of interest, but not to achieve a common goal.
- Level 3: At the highest level, collaborators operate as a team to achieve a common purpose by working together and gaining new insights.

Although collaboration is widely accepted as the most efficient method for creating value some important barriers of knowledge sharing arise leading to the creation of *non-collaborative* environments to be further discussed in [Section 2],

environments that only reach the first or the second level from the above proposed list.

These environments found to exist mostly in developing economies, usually have less understanding of the Knowledge Management concepts, and less or no experience in using and implementing such systems. Thus implementing Knowledge Management Systems i.e. Information Systems that offer collaborative software as well as allow storing and dissemination of information, can provide significant challenges, such as:

- Resistance to change: complex systems made up of individuals with a reduced opening to knowledge sharing have a strong inertia and can be difficult to accept new systems.
- Lack of long term support: although short-term support can be assured in an organisational system where personal interests are the main priority long-term support is difficult to maintain.
- Lack of funding: in an organisation where knowledge sharing is not well understood thus has a low priority, necessary funding for systems implementation can be insufficient.

In such a context, the implementation of Knowledge Management Systems can be thought of as a *leap* – thus acknowledging the importance of speed in the process, by bypassing some of the steps usually proposed by traditional implementation approaches and developing new, creative methods to help fill the gap between organizations in developing economies and their counterparts in more mature, developed economies.

## 2 Knowledge Sharing in Developing Countries Universities

The political context of developing countries still has an increased impact on the quality of the universities, both regarding research conducted and educational activities: only 1% of universities mentioned in most European universities rankings are from Eastern Europe, based on several reviews such as the THES - QS World University Rankings [QS, 2007].

As paradigms on knowledge and knowledge creation shifted from the academic world towards corporations and other professional organisations [Bleiklie and Byrkjeflot, 2002] and with the impact of Globalization that led to “education being regarded as a commercial product, governed essentially by market forces” [Mohamedbhai, 2003], universities in developing countries found themselves in a strong competition both on a national and on an international level.

Furthermore, knowledge becomes more and more valued and thought after on a global scale. Some authors [Bleiklie and Byrkjeflot] even consider that relationships established between major actors in the area of knowledge production and dissemination (politicians, institutional leaders, researchers and business leaders) are based on three concepts: knowledge interests, knowledge alliances and knowledge regimes (where regime is defined as referring “both to a formal aspect, a form of governance and a procedural aspect, a manner of governing and comprises thus both the structures and processes of governance”).

Considering this and the fact that in developing countries some political and social instability still exists, it is safe to say that the competition between

organisations duplicated to a competition inside each organisation, where employees compete for acknowledgement, better positions and increased revenues. Personal interests still carry a lot of weight and when competitive advantages are based on personal knowledge – such as in the case of universities, *knowledge sharing* is less embraced.

One of our first projects regarding Knowledge Management aims to implement a Knowledge Management System at the “1 Decembrie” University, Alba Iulia. The project has a pilot-phase – implementing the system for the Department of Mathematics-Informatics and based on its results further implementation is to be discussed.

The current situation is that of a non-collaborative environment situation that was established based on a small survey conducted among the members of the department. The questionnaire based study was run on all the members of the department thus making its results reliable and representative.

The questionnaire comprised of several themes spread through 20 questions and shows among others the degree in which respondents know the concept of Knowledge Management, how they see its importance for an organization and some variables that assess the knowledge sharing practices: the number of articles / books or other type of research offered to colleagues and the number of article / books or other type of research received from colleagues.

The findings are as follows:

On the first theme – *KM concept awareness*, we found that only 50% of respondents know what Knowledge Management implies. Looking further, at the level of understanding respondents claim to have, 50% of the respondents that know what KM means (25% of all respondents) have a basic knowledge of the concept and 50% (or 25% of all respondents) have a medium knowledge of the concept. None of the respondents claimed to have a good understanding of the concept through study and / or practical experience. Another related finding was the importance of the subgroup respondents were part of: Mathematics group and Informatics group. The findings show that the respondents from the Informatics group have more knowledge regarding KM Systems than the Mathematics group: 71,4 % to 20% (the 50% average is achieved because the Informatics group is slightly larger than the Mathematics group). Interesting was also the fact that age does not seem to have an effect on KM awareness, the answers being spread evenly among the three age intervals proposed: under 25 – 40, 41 – 55 and over 55.

Considering the importance of KM Systems in the university, the findings show a “positive feedback” with 25% of respondents choosing “useful” and 25% of respondents choosing “very useful”. 50% were missing answers, since those respondents do not know the concept of KM thus cannot have an opinion regarding its importance. Another interesting aspect is the tendency to give more weight to KM Systems as the personal knowledge of the concept increases (the Spearman and Pearson correlations show a direct connection even if it is only a medium connection).

Furthermore, considering the agreement to implement a KM System in the university and also the agreement to help in such an implementation, we found that no respondent is against it: 67% are positive towards it, while 33% can't answer / don't know. Moreover, 58% of respondents agree to help in an implementation project even though most of them (43%) only offer a couple of hours each week.

Regarding KM barriers, from the 50% that answered the question we found that 83% consider there will be difficulties for the implementation of KM Systems with the main one being the difficulty to change existing mindsets and systems (60% of the respondents who answered there could be problems). Other barriers were lack of time (20%) and poor communication (20%). The age of the respondents came into effect here, but in a awkward way: most of the respondents over 40 years old didn't answer the question (either because they don't know what KM is, either because there are not sure regarding problems that may arise), while most of the respondents under 40 said there will be some barriers. That basically implies that the younger respondents believe that the current mindset will be the most difficult thing to overcome and that this is mostly due to their older colleagues. However, we would like to underline a limitation of our study in this aspect – the fact that 75% of respondents were in one age category. Further inquiry is necessary, including rearranging the age intervals.

Communication and overall collaboration and appreciation among colleagues is another aspect we tried to assess. First we asked the respondents to name three of their colleagues and their taught subject, with the professor-subject association being our main interest. Only 58% of the respondents could name all three and 16% named only two. Some (8.3%) could not make any correct professor – subject association and some made only one correct association. When analysing the mentioned professors we found that the most named professor was the newly appointed head of department and the second most named professor was the head of the International Relations department – which could imply that formal power is an important aspect of the respondents mentality. When looking at this issue while considering the two groups we found that 90% of answers from the mathematics group named other professors in the mathematics group (and 10% from the informatics group) while 80% of answers from the informatics group named professors in the same group. This shows that group belonging is still highly important and more important for the mathematicians, mathematics being the older of the two groups.

The other ways we tried to assess communication and collaboration was to ask the respondents to name five of their colleagues and their research interests and also five colleagues and their extracurricular activities. The findings show no profound communication practices: only 50% could name five professor – research association and most of respondents (58%) could not name at least one extracurricular activity of their colleagues.

Regarding Knowledge sharing, most respondents (90%) said they have received 0-5 books or articles from colleagues and all respondents admit to not having written any review for books / articles of colleagues. What we found to be intriguing is a contradiction between received books and articles and offered books and articles: 50% of respondents considered they did offer some of their work to colleagues (25% consider they offered 10-25% of their work and 25% consider they have offered over more than 50% of their work). While we cannot at this point be sure of all the reasons that led to this contradiction, we can imply a certain lack of structure: while some might have received papers from colleagues they didn't find the time to read them, or even forgot about receiving them and on the other side some might have had the intent to offer some works to colleagues but didn't actually do so. Another aspect we take into account is the difference in scale: while the first question had a value based scale (0 to 5 articles, 5 to 10 and so on), the second had a percent based scale (0-10%)

that could fit in some specific contexts. The percent based scale was chosen because of the need to determine not only the actual number of papers offered by respondents to their colleagues, but also (and more importantly) the degree of openness – what that number represents (10% of 5 papers is different than 10% of 50 papers). We are considering some change for the scale of these questions and even adding more questions or an in-depth interview to better evaluate the sharing policies.

The last issue that we wanted to determine is how respondents consider their colleagues' abilities as teachers and researchers as well as how they see themselves in relation to their colleagues. The findings show a slight positive feedback, most of the respondents (54%) consider that the general level is “good” (on a scale consisting in below average, average, good, very good), while 36% consider the level as “average” and 10% as “under average”. Considering their relation to their colleagues, 30% consider themselves to be better than the average of their colleagues and 70% consider themselves to be at the same level. When running a cross-tab between the two variables, we found a slight opposite link: respondents who consider themselves better have more expectations thus they see the general level lower. This finding could be another factor to take into account in relation to the non-collaborative environment: lack of knowledge is considered one of important barriers towards knowledge sharing (as shown by [Hew and Hara, 2007]).

To sum up the conclusions of our study, we have found that:

- KM is a concept that is not very well known.
- People tend to give a positive feedback – agreeing with the implementation of such a system and even considering offering some of their time.
- The most important barrier to KM implementation is considered to be the *mentality* switch. The younger people are more likely to consider this a major issue and there is an important probability that they imply the switch of the mentality of their older colleagues.
- Communication and collaboration is *chaotic* at the department level. People tend to know others in their own group and have less deep interest in their colleagues. The mathematics group is more homogeneous but also more *enclosed*, while the professors from the informatics group are more individualistic. Also, the best known colleagues are those who hold important administrative positions.
- Knowledge sharing is also *chaotic*, not structured and very underdeveloped. It is highly likely that this leads to confusion regarding each person's abilities.
- The respondents tend to consider themselves slightly better than their co-workers but are confident about the general average abilities.

### 3 The Leap to Knowledge Management: Avoiding Pitfalls of Traditional Models

The implementation of a Knowledge Management System (KMS) can be seen as a *public good social dilemma* [Cabrera, 2002]: why would I contribute to the public good when other might not thus wasting my time and not getting anything in return?

One of the first measures we propose is similar to that proposed by Cabrera – the restructuring of the payoff function but with several amendments. First of all we would like to emphasise the role of the monetary incentives of most developing countries and while social status is desirable, the financial rewards are more looked after. Furthermore we would like to emphasise the role that administrative management has in developing countries (as revealed in the study) – thus making it necessary for official KM policies to be established: participation will thus become mandatory, being added to the job description of faculty and researchers and also to the promotion criteria of the university.

Furthermore, we agree that both quantity and quality of inputs from the system users have to be taken into account but the evaluation methodology has to be especially well designed: for instance, the grading of the value of inputs should take into account external reviewers (where it is possible). For taking into account the internal benefit, users may rate a particular answer but only with positive ratings if they consider the input as very useful, but a negative rating should not be allowed to avoid the possibility of penalty grading based on personal differences. Also, indirect measures such as number and frequency of access for each input should be taken into account to determine quality.

In regard to the solution that proposes promoting group identity and personal responsibility [Cabrera, 2002] we consider that while it could work in some environments, trying to apply it here will run into the barriers of *chaotic communication* and *non-collaborative environments* (as shown in section 2). The deficient group identity is anchored in the current mind-set (the major barrier to KMS identified in section 2). In order to promote group identity and personal responsibility, specific steps have to be taken to ensure the change of that mind-set (mentality), a process that will have to face the same mentality. Thus we consider that a promotion of group identity is more a consequence of the leap to KM than it is one of its prerequisites.

Another one of the pitfalls we would like to address in relation to traditional knowledge management approaches is the time such a process requires to be understood, accepted and put into practice.

The lack of time is in fact widely considered to be a barrier for knowledge management implementation. A study conducted by the *Knowledge Management magazine* and IDC credits the lack of time as the main barrier for Knowledge Management (41% of respondents) [Milam, 2001] while our study showed 20%.

The barrier time, however is considered to have a strong relationship with the concept of prioritizing [Hew and Hara, 2007] and can be avoided by developing a permanent KM team or department that will:

- periodically remind faculty of the need to publicize their work in the KMS, even publishing themselves the works of their colleagues after they ask for permission;

- conduct a lobby activity on a management level to ensure that high importance is given to KM and that the policies are enforced;
- conduct lobby activities among peers to increase visibility of the KMS and its results;
- ensure the proper functioning of the Information Systems in place;
- periodically conduct evaluations of users opinion on the system as well as the system's efficiency.

To further address the non-sharing culture, as described in [Section 2], we propose going beyond external motivation (social, monetary or regulatory) into internal motivation. Practical benefits from knowledge sharing have to be observed and promoted. Occasional studies can be conducted to show actual benefits in terms of personal development. Another two steps could help internal motivation:

- Attracting informal internal leaders: every team has beside formal leaders one or several informal leaders that have an important impact on the team. Attracting them to use and promote the system could lead to an important motivation boost.
- Adding value to the knowledge management system. from external sources: establishing relationships with other systems (such as on line databases) and even publishing work from external sources in the system can increase its value thus increasing its use.

Related to the issue of technologies and tools used to implement Knowledge Management we are faced with new concerns: the lack of experience can easily lead to choosing the wrong tools and persuading management to committing to a large monetary investment with probable long-term return could be a difficult task. Developing a personalized basic system can overcome this issue since the costs incurred could be much less and the experience gained in this process could be the basis for further proposals. Furthermore, an integration policy to integrate existing systems could speed up development and implementation (such as using personal e-mail address in stead of creating a new asynchronous messaging platform).

#### **4 Conclusions and Future Work**

The current paper shows that universities in developing countries are characterized by a smaller degree of understanding and supporting Knowledge Management, in part based on the existent culture and mindset – less opened to sharing.

As developments in the field are progressing rapidly, there is a need for most universities in developing countries to “catch up”, to leap over some well-documented barriers and to bypass some of the pitfalls of traditional approaches to the implementation of a Knowledge Management System. Providing monetary and social incentives, adding knowledge sharing as criteria for promotion and evaluation as well as making the system more valuable by establishing relationships with external authors are a few of the envisioned steps that could allow that leap to happen.

Our future work aims to pursue the for-mentioned theories and develop and implement a Knowledge Management System at the “1 Decembrie” University in Alba Iulia, Romania so we gain further insight in knowledge sharing practices and the ways through which these can be improved.

## References

- [Bleiklie and Byrkjeflot, 2002] Bleiklie, Ivar and Byrkjeflot, Haldor, *Changing knowledge regimes: Universities in a new research environment*, Higher Education 44 pages 519–532, Kluwer Academic Publishers, Netherlands, 2002.
- [Cabrera, 2002] Cabrera, Ángel, Cabrera, Elizabeth F, *Knowledge-Sharing Dilemmas*, Organization Studies, 2002, 23 (5): 687-710.
- [Hew and Hara, 2007] Hew, Khe Foon and Hara, Noriko, *Empirical study of motivators and barriers of teacher online knowledge sharing*, Association for Educational Communications and Technology, published online on <http://www.springerlink.com>.
- [Ion, 2007] Ion, Alina-Mihaela, *Knowledge Management Methodologies*, published in the Proceedings of the Eight International Conference on Informatics in Economy – Informatics in Knowledge Society, ASE Printing House, Bucharest, 2007.
- [Madanmohan, 2005] Rao, Madanmohan, *Knowledge Management Tools and Techniques* Oxford, UK: Elsevier Butterworth–Heinemann, 2005, pag. 350.
- [Milam, 2001] Milam, John H., *Knowledge Management for Higher Education*, ERIC DIGEST, published on <http://www.eric.ed.gov/>, 2001.
- [Mohamedbhai, 2003] Mohamedbhai, Goolam, *Globalisation and Its Implications on Universities in Developing Countries*, in G. Breton and M. Lambert, eds, *Universities and Globalisation: Private Linkages, Public Trusts*. Paris: UNESCO/Université Laval/Economica.
- [QS, 2007] Times-QS World University Rankings, available online (June 2008) at: <http://www.topuniversities.com/worlduniversityrankings>
- [Schrage, 1995] Schrage, Michael, *No More Teams! Mastering the Dynamics of Creative Collaboration*, DoubleDay, 1995.
- [Schrage, 90] Schrage, Michael, *Shared Minds - The New Technologies of Collaboration*, Random-House, Inc. New York, 1990.



## **Growth and Sustainability in Online Social Networks**

**Günther Ossimitz**

(Alpen Adria University Klagenfurt, Klagenfurt, Austria  
guenther.ossimitz@uni-klu.ac.at)

**Christian Russ**

(Alpen Adria University Klagenfurt, Klagenfurt, Austria  
chr@uni-klu.ac.at)

**Abstract:** Today Online Social Networks (OSN) are very popular Web sites which show remarkable user growth and attention on the Internet. One reason of the extraordinary success of these social software sites are the enhanced Web 2.0 technologies and concepts, but they do not really explain why a OSN in particular produce explosive growth while another similar Web site is drying out. We believe that these socio-technical mass phenomena can be better understood by introducing self-organization theory (SOT) and crowd behavior. These concepts can explain why spontaneous collective- and herd behaviors may emerge and how the development of these processes could look like. However OSN should not only grow fast, they also want to stay sustainable and get profitable. Hence an important question of these potential “overshoot and collapse” Web sites on the Internet is how to get it stabilized and turned into a long lasting and successful service. Therefore we present some considerations about growth and sustainability in the dynamic and competitive online world.

**Keywords:** Online Social Networks, growth and sustainability, self-organization, mass behavior

**Categories:** H.5.1, H.5.4, J.4., K.4, L.6.1

### **1 Introduction**

An online mass phenomenon can be defined as an event or situations where masses of users gather virtually on the Internet and produce collective behavior which can lead to extraordinary results. Most of the Internet behaviors are self-determined by the users and they follow rational arguments why visiting a Web site or registering an online service. But sometimes, in rare cases collective behavior turns into a self-enforcing and self-accelerating development process, where users tend to behave like an online herd. They observe and imitate the behavior of other users and follow online trends without a rational reason. These “mind infected” users can be seen as “Online Crowds” (OC) who can amplify the usage and growth of a Web site or vice versa can be the reason that an established Web site is stagnating [Russ, 07]. Prominent examples are Online Social Networks (OSN) which are growing exceedingly fast and attracting a lot of users (hypes) but on the other side a lot of similar OSN clones are suffering by absence of users and publicity (flops).

In the first chapter we introduce several models of system growth as a fundament of system dynamics. Afterwards we use the principles of Self Organization Theory (SOT) and Self Organized Criticality (SOC) to explain online growth and emergent

mass behavior on the Internet. Furthermore we apply the before mentioned theories on two popular OSN and conclude with some considerations about requirements for sustainability and stability of emerging online communities.

## 2 Models of system growth

Growth is a very fundamental systems concept. It is defined as change over time in a certain direction: things become bigger. In Biology it is associated on the level of a single living entity with growing up from a child state to a mature status [Bertalanffy, 76]. On the level of a population it is associated with the spread of populations until an environmental capacity limit is reached. In business life growth is often considered to be the key factor for success or even used as a synonym for prosperity: “the bigger the better”.

It is important to differentiate between the state of a system and its change (eg. growth). In System Dynamics modelling [Sterman, 06] one discerns between stock variables referring to time-points and changes of these stocks over time-intervals via associated flows (inflows and outflows). For example a population is a stock-variable having a certain value at each time point. Births and immigrations are inflows, deaths and emigration are outflows of the stock, happening over certain time intervals. Empirical investigations [Booth-Sweeney, 00], [Ossimitz, 02] have shown that even highly educated persons tend to mix up flows with stocks and erroneously infer from the decrease of an inflow (which just slows down the growth but lets it still grow) a decrease of the stock.

### 2.1 Mathematical Models of Growth

Mathematical models of growth can be divided into two big categories: limited and unlimited growth – given an infinitesimal amount of time. For the unlimited case the linear and the exponential growth are the two most basic types. In the linear case the absolute increase over a certain period of time is constant. No matter how big or small the state variable is the growth rate over a fixed time interval is always constant. For the exponential case growth is both proportional to the existing stock and also to the fixed growth-factor.

### 2.2 Limited Growth

For real-world systems absolute growth of some state variable over a finite time interval is always limited. This also implies that only finite values of the state are reachable within finite time. Hence it is also true for exponential growth, which grows towards infinity when time is allowed to pass on forever, except for a finite time-interval. Even over a hypothetical infinite time-span the state of many systems would stay always finite. This applies due to the finiteness restriction of our world, which allows neither infinitely tall persons nor unlimited big populations or infinite big amounts of money. Typically this limitation to growth can be specified by some kind of specific limitation (carrying capacity). A market share cannot go beyond 100%, and also the absolute size of any market is always finite.

There are different models of limited growth. Typically these models contain a limit of growth (maximum carrying capacity), which is assumed to be given as a free to choose constant for the growth process. A simple example for a limited growth process is growth that goes without any restriction until the given carrying capacity  $K$  is reached. At this level growth stops immediately and forever. This model applies e.g. for filling a rain-barrel with water or for booking seats for an airplane flight, where the additional seats might be booked without problems until the plane is full (not taking into account strategies of overbooking). The growth rate changes in this type of model immediately from some finite value to zero as soon as the capacity limit  $K$  is reached.

In many cases it is preferred that the growth becomes slower as the capacity limit  $K$  is approached. A very simple approach is to formulate this as:  $u'(t) = k*(K-u)$ , which leads to a Bertalanffy-type growth function [Bertalanffy, 76]. The growth stops when  $K=u$ , for  $K-u$  becomes zero. Normally the difference  $K-u$  decays exponentially over time.

Another important model of limited growth is the logistic model. The basic idea is that the growth is proportional to the given state  $u(t)$  and the growth factor  $k$  and free space  $F$ , which is the proportion of  $K$  is not yet being occupied by  $u$ :  $F = 1 - u/K$ .

Thus  $u'(t) = k*u*F$  and yields an S-shaped logistic growth curve and the growth is proportional to three factors. If  $u$  is considerably smaller than  $K$ , then only a small proportion of the available capacity is actually occupied and  $F$  is just a little bit below 1. This allows the growth to be of exponential type as long as  $u$  is small in comparison to  $K$ . When  $u$  becomes bigger the limiting factor  $F$  becomes more and more important. As in the case of the Bertalanffy Growth the whole process stops when  $u=K$ , because then  $F$  becomes zero and so  $u'(t)$  becomes zero, too.

### 2.3 Overshoot and Collapse

An important and disastrous case of limited growth is “overshoot and collapse”. It happens whenever a system has a carrying capacity  $K$ , which is actually ignored by the growing forces, so that the overgrowth goes considerably beyond  $K$ . A remarkable and well-documented example for an overshoot-and-collapse-behaviour is the case of the deer population in the Kaibab Plateau in 1905-1930 by [Rasmussen, 41]. The Kaibab Plateau is bordered by the Grand Canyon, the Kanab Canyon on three sides and by a high desert in the north, allowing the deer population there no escape to other regions. When hunting of the natural enemies of the deer (pumas, coyotes, wolves) was allowed in 1906, the deer population started to grow from about 4.000 to about 100.000 until 1924. The forests and grasslands of the region could at most supply about 30.000 deer. Since the number of deer grew considerably above this limit, they eventually consumed almost all of the green plants of the plateau in order to secure their survival. From 1924 to 1926 about 60.000 deer died of starvation, despite of massive nourishing programs started by the National Park Authority. The systemic reason for this catastrophe simply was that the deer did not stop growing in number when the carrying capacity of about 30.000 was reached in 1916, but the growth continued until the deer had destroyed their own basis of survival.

### 3 Self organization in online mass phenomena

#### 3.1 Dissipative systems and self organized criticality

Self organization theory (SOT) is one approach to explain emergent behavior in social processes and helps to provide a theoretical framework supporting the development of such growth processes. In detail SOT systems tend to build up new structures as a response to external circumstances and are able to influence elements of their system without explicit control [Heylighen, 99] [Kurihara, 98] [Banzhaf, 02]. Moreover these kind of open systems are highly dynamic, non-deterministic, self-maintaining and sometimes employ unexpected emergent phenomena of reactions [Johnson, 02].

Online mass phenomena which produce “Online Crowds” patterns cannot be explained easily by analyzing the elements of a system independently: To understand the social mass processes on the Internet we use some characteristics of SOT and adopt them to the observed phenomena of the Web. According to [Bak, 87], [Kurihara, 98], [Heylighen, 99], [Banzhaf, 02], [Johnson, 02] and [Ossimitz, 06] systems based on SOT can be described by properties like complexity, global order from local interactions, autonomy, redundancy and resilience, self-referentiality and feedback loops [Richardson, 91], non linearity, organizational closure, bifurcations and symmetry breaking.

Moreover there is an important concept of SOT which is known as dissipative structures, describing dynamics which are far from equilibrium state. [Prigogine, 77] introduced the concept of dissipative structures as non equilibrium thermodynamic systems which generates spontaneously order with new and stable structures. This is conducted by absorbing (dissipating) energy from their external environments until it reaches a critical point of energy input and a bifurcation is happening. In Figure 1 the generalized approach is used from [Bak, 87], [Russ, 08], [Ossimitz, 06] and presents the stationary states of dissipative structures.

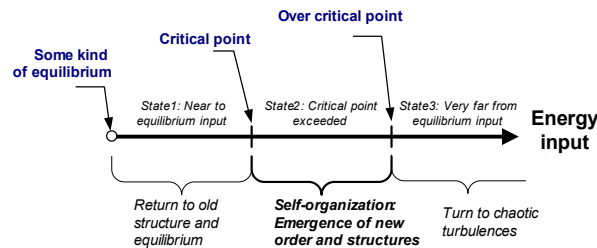

Figure 1: Stationary states of dissipative structures [Russ, 08]

Starting from left to right, the left side equilibrium is some kind of stable state where a system resides and the entropy is very low and no energy is dissipated. Without the extraneous cause of additional energy, it will remain in this minimized energy state. However, if there is an asymmetric input of new energy on the system, it starts to dissipate the energy and a shift away from the equilibrium is happening. Depending on the degree of the energy input and the durability it can pass following stages:

- *Near to the equilibrium*: If the energy contribution is not high enough or ending up early the system will move right back to the prior equilibrium state. The energy input is *under critical* and does not change the system.
- *Critical point exceeded*: If the amount of energy influx exceeds the threshold of the critical point the system can emerge towards self-organization and build up a new order with different stable structures. Consequently small instabilities and positive feedback loops in the system can lead to irreversible bifurcations and new stable system states afterwards [Heylighen, 99]. The energy input is *over critical* and has to persist to keep the established structures alive.
- *Very far from the equilibrium*: In some cases the energy input continues to grow and the system moves to the last possible state: chaotic turbulences. At this time the energy input is *beyond the over critical point*. If a system falls into this state it turns to chaotic behaviors and build up structures can collapse.

This overall dynamic of dissipative systems can be seen as a kind of self-organized criticality (SOC) [Bak, 87] and [Banzhaf, 02]. The SOC model states that large dissipative systems can drive themselves to a critical state where unexpected and new structures or forms of orders can emerge. Consequently SOC can be applied to a diverse set of phenomena, e.g. ecological disasters, economic dynamics, biological evolution and emergent social systems. In [Beckenkamp, 06], complex collective behaviors similar to “Online Crowds” (OC) can apply to the same principles of SOT and SOC.

### 3.2 Development phases of online mass phenomena

We assume that the development of an extraordinary online mass phenomenon with exponential growth is driven by the emergence of “Online Crowds” (OC) [Russ, 07] who behave like herds, imitating and following the trends of other users. This concept of “other directedness” [Riesman, 82], [Bonabeau, 04] is well known in various research areas of social psychology, mass psychology and economics [Russ, 07]. From the social point of view this theory helps us to understand how people tend to react collectively and how crowd behavior can evolve.

Figure 2 demonstrates the typical but rare development and the involved phases of an online mass phenomenon driven by an OC over the time. Every phase of this social process is accompanied by a transition and a threshold which leads into the next phase. If we combine the principles of OC with the theory of SOC we can find several similarities in the characteristics identified before.

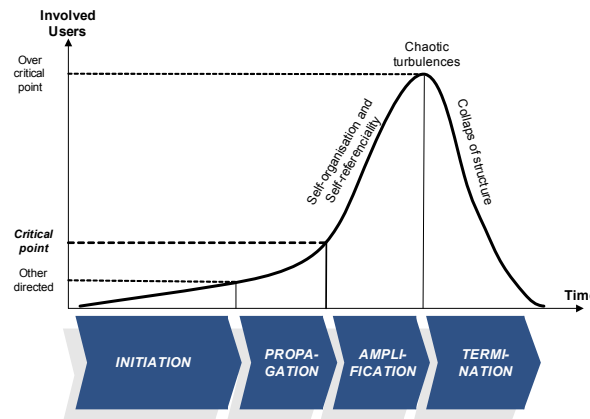

Figure 2: Development and phases of a mass phenomenon (Online Crowd)

The detailed requirements, circumstances and the details of an “Online Crowd” (OC) is described in [Russ, 07] and [Russ, 08], hence this paper concentrates on the similarities between the OC model and the SOC of dissipative systems.

- *Initiation*: Every OC needs an initial trigger, which induces the “initiation phase”. From the SOC point of view this is represented by an initial energy input which increases the entropy of the system. Typical triggers are the mass media, innovations or some displacement in the social or political fabric. If the energy input is strong enough, the initiated users are in a higher state of attention. Else, if the energy is diminishing the process is dying out before it really started.
- *Propagation*: In some cases the energy continues to grow by additional psychological accelerators like trend setters, increased media coverage, assumed advantages and others. New users begin to look at the behavior of others (*other directedness*) and the signals of the accompanying users are getting more and more an appeal to follow them. The concept of imitation is documented in various areas like social learning [Celen, 04] and information cascades [Bikhchandani, 98], [Bonabeau, 04] as well as network externalities [Katz 85], to name only a few of them.
- *Amplification*: So, if the energy is still dominant and growing because of new joining users, increased spread about the buzz and media awareness, the most important threshold of the process can be reached: *the critical point* of involved users. When this barrier is broken, the process turns into a new form of self-organizing structure and order and can show exponential growth characteristics. The system state is producing self-referential, self-enforcing and self-accelerating patterns which lead to herd like behavior and hypes [Beckenkamp, 06], [Russ, 07]. From this point on the growth of the mass phenomenon is rapidly changing from a linear to a non linear pattern and temporary effects like euphoria are emerging. Hence the energy input is still increasing; positive feedback loops are multiplying it [Arthur, 94] and the chain reaction of “infected” online users is fully deployed.

- *Termination*: According to the overshoot-and-collapse principle, the energy input can not last for ever and the euphoria is switching to hysteria. With the attainment of the *over critical point* of involved users the whole phenomena is getting instable and showing first signals of chaotic turbulence. From this point on the same leveraging forces which boosted the process are now accountable for the collapse of the phenomenon. In some cases the hysteria is changing into panic, in other cases the simple absence of addition psychological, social and media based energy, as well as the time as attrition rate stops the mass phenomenon. In other cases a mass phenomenon is simply replaced by another, so the OC is moving from one trend to another.

## 4 Application scenario: Online Social Networks

Online Social Networks (OSN) like MySpace.com, Facebook.com, Bebo.com and Friendster.com, to name just a few, are promising areas to explore self-organized criticality (SOC) and "Online Crowds" (OC) patterns. These Web sites are very user-centric and massively dependent on how efficiently imitation signals can spread to existing and potential users. The principle idea of OSN is to build and maintain communities of personal social networks which have similar interests or which are interested in exploring the interests and activities of others [Boyd, 07].

Therefore, these online platforms offer various ways to communicate and interact with each other. One of the major principles of OSN is the "visibility" of the other participants who flock together in this online community. Hence there are virtual profiles of users as well as the possibility to connect with each other in a network of linked trusts. These virtual social networks enable the individuals to propagate and distribute information very easily through the electronic channels and to reach a broad audience with the same content and ideas. Additionally, most of the content and information about the online individuals are public and free to access for everyone on the web. Thus it is quite easy to search and observe the actions of others in these OSN. In November 2006 the 10 most popular domains accounted about 40% of all page views on the Internet and nearly half of the views can be credited to the OSN systems like MySpace.com and Facebook.com [Breslin, 07]. These online networked users are offering a high potential for OC behavior and the spread of rumors, fads, and trends.

### 4.1 Comparison of Friendster.com against Facebook.com

One of the first online social networks (OSN) was Friendster.com. This Web site started early in 2003 and had a great potential to get a blockbuster in this online segment. The service was stable, had already some online presence and several million of venture capital, which presented a perfect environment to grow fast and get successful. But the opposite went reality; the late bloomer in 2006, Facebook.com has stolen the show and got the winner in the race [Chafkin, 07].

So the interesting point is why did these two OSN services developed that different as shown in Figure 3. We assume that the presented page views somehow correspond proportionally with the number of active users. Friendster.com had 3 years lead over Facebook.com and was a US-based spin-off with a promising outlook. At

the beginning both were growing very slowly, but suddenly at the beginning of year 2007 there was a change into a clear non-linear trend. Even more, mid of 2007 there was a massive bifurcation going on. Friendster.com was abruptly going to stagnate, but Facebook.com was overshooting and reaching the domination of all major OSN sites. Today Facebook.com is ruling the OSN market and Friendster.com has lost lead in this market segment.

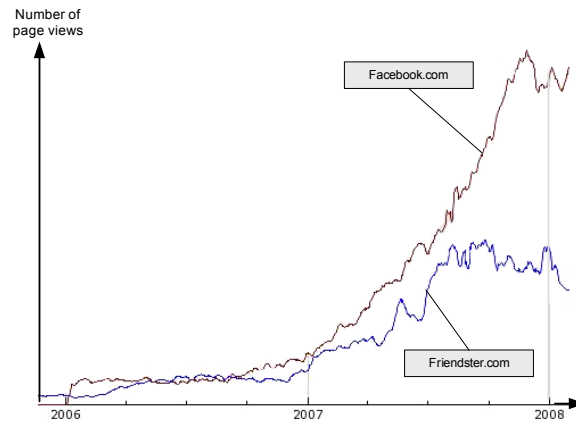

Figure 3: Development of page views of two OSN [Alexa, 08]

From the self-organization theory and the OC point of view there are some particularities to mention. During the year 2006 both OSN reside in the initiation phase and users have chosen the service which was present first or which fits best to their needs. But with the last quarter of 2006 a transformation into the propagation phase started. Users started to transform from self-directed to the other-directed behavior and preferred the OSN more, which was also used, recommended and listed by others. Somehow the critical point of self-organized criticality (SOC) of new users was reached with beginning of 2007. Hence the development turned into the amplification phase and had two remarkable effects: Facebook.com escalated and turned into a self-enforcing and self-accelerating blockbuster, despite Friendster.com escalated also but into the opposite direction. Although it was growing at the beginning of the amplification phase (maybe because of the bandwagon effect), finally the escalation was operating into the counterproductive direction. The same mechanism which boosted Facebook.com upwards took Friendster.com downwards and the similar mechanisms of self-enforcing and escalation opened the negative trend. Consequently one OSN won the race against another by reaching a critical mass of online users who have decided themselves for one online service and afterwards the process of exponential growth to the top or the inevitable termination was fulfilling itself.



## 5 Implications about online sustainability and growth

The most important condition for a system to be sustainable is that it must be able to exist independent of extreme growth. This implies that a system which requires growth as a necessity for its existence (e.g. like Ponzi-schemes, financial bubbles and hypes) will inevitably die out. So OSN have to be designed to be able to perform both under growth and non-growth conditions over some period. Another important aspect to take into account is that “other directedness” can have two-sided effects. On the one hand it might attract “other-directed” people to the OSN, on the other hand people tend to leave a Web site because of others leaving too. For a sustainable development it is relevant that people are sharing a site due to self-directed (intrinsic) motivations. From the ideally case an OC can transform into a sustainable online community if it fulfils most of the following properties: (a) the content is provided by active users themselves (also known as user generated content [Preece, 01]); (b) the content is also interesting for visitors, who initially not necessarily have to share content; (c) the organization and the quality of the content is driven by the users themselves (self organizational behaviours [Beckenkamp, 06]); (d) the more comprehensive the content becomes the more attracting the Web site will get (path dependence [Arthur, 94]); (e) the content does not become outdated or irrelevant quickly just by time passing by and it keeps its value even if active users leave the Web site; (f) new users can build upon the existing content and structures of former users.

Two examples which somehow fulfil all these criteria are Wikipedia.org and flickr.com, which started originally in one language, but prospered over the years to a multilingual community. Concerning the sustainability of OSN an additional critical factor in the long term might become the increasing number of inactive users with outdated or wrong information.

## 6 Conclusions and future work

This paper has presented an approach to better understand the raise and the break down of cometlike Web sites on the Internet. Successful OSN show a lot of similarities with the patterns of “Online Crowds” and SOC, which often can grow in an overshoot-and-collapse-manner. The theoretical conditions for sustainability imply that an OSN must also be able to function well when having reached some limits of growth. Future research have to address this, how to deal with the problem of outdated content and how to identify “natural” limits to growth in OSN. Furthermore it would be interesting to demonstrate the theories on real-world data sets and to identify the exceptions of this approach.

## References

- [Alexa, 08] Alexa – The Web Information Company, Graphic Graph Daily Pageviews, 2008, <http://www.alexa.com>
- [Arthur, 94] Arthur, W. B.: *Increasing Returns and Path Dependence in the Economy*, University of Michigan Press, 1994

- [Banzhaf, 02] Banzhaf, W.: Overview of self-organizing systems in Science, In: Encyclopedia of Physical Science and Technology, Academic Press, New York, Vol. 14, pp. 589-598, 2002
- [Bak, 87] Bak, P., Tang, C., Wiesenfeld, K.: Self-Organized Criticality: An Explanation of 1/f Noise, *Physical Review Letters*, vol. 59, pp. 381-384, 1987
- [Beckenkamp, 06] Beckenkamp, M.: The Herd Moves? Emergence and Self-organization in Collective Actors, Max Planck Society for the Advancement of the Sciences - Max Planck Institute of Research on Collective Goods, MPI Collective Goods Preprint No. 14, 2006
- [Bertalanffy, 76] Bertalanffy, L. von: *General System Theory*, Braziller (George) Inc., U.S., 1976
- [Bikhchandani, 98] Bikhchandani, S., Hirshleifer, D., Welch, I.: Learning from the Behavior of Others: Conformity, Fads, and Information Cascades, *American Economic Association in Journal of Economic Perspectives*, pp.151-170, 1998
- [Bonabeau, 04] Bonabeau, E.: "The Perils of the Imitation Age"; *Harvard Business Review Article*, Jun 1, pp.45-47, 49-54, 2004
- [Booth-Sweeney, 00] Booth-Sweeney, L., Sterman, J.: Bathtub Dynamics: Initial Results of a Systems Thinking Inventory. *System Dynamics Review* 16(4), pp. 249-286, 2000
- [Boyd, 07] Boyd, D., Ellison, N. B.: Social Network Sites: Definition, History, and Scholarship, *Journal of Computer-Mediated Communication*, Vol. 13, No. 1-2, 2007
- [Breslin, 07] Breslin, J., Decker, S.: The Future of Social Networks on the Internet – The Need for Semantics, *Digital Enterprise Research Institute, Galway, IEEE Internet Computing* pp.87-90, 2007
- [Chafkin, 07] Chafkin, M.: How to Kill a Great Idea!, *Inc.com*, Juni 2007, <http://www.inc.com/magazine/20070601/features-how-to-kill-a-great-idea.html>, 2007
- [Celen, 04] Celen, B. and Kariv, S.: Observational learning under imperfect information, *Games and Economic Behavior* 47(1), pp. 72-86, 2004
- [Heylighen, 99] Heylighen, F.: The Science of Self-organization and Adaptivity, In: *The Encyclopedia of Life Support Systems*, 1999
- [Johnson, 02] Johnson, S.: *Emergence: The Connected Lives of Ants, Brains, Cities, and Software*, Scribner Book Company, 2002
- [Katz, 85] Katz, M.L., Shapiro, C.: Network Externalities, Competition, and Compatibility, *The American Economic Review*, Vol. 75, No. 3, pp. 424-440, 1985
- [Kurihara, 98] Kurihara, S., Sugawara, T. and Onai, R.: Self-organization based on nonlinear nonequilibrium, *Dynamics of autonomous agents; Artificial Life and Robotics*, Volume 2, Number 3 / September, 1998
- [Ossimitz, 02] Ossimitz, G.: Stock-Flow-Thinking and Reading stock-flow-related Graphs: An Empirical Investigation in Dynamic Thinking Abilities. In: *Proceedings of the System Dynamics Conference 2002*, Palermo
- [Ossimitz, 06] Ossimitz, G., Lapp, C.: *Das Metanoia Prinzip - Eine Einführung in systemgerechtes Denken und Handeln*, Franzbecker Verlag, Hildesheim, Berlin 2006
- [Prigogine, 77] Prigogine, I.: *Time, Structure and Fluctuations*, *Novel Lecture*, 8 December, 1977

- [Preece, 01] Preece, J.: "Online communities: Usability, Sociability, Theory and Methods."; In R. Earnshaw, R. Guedj, A. van Dam and T. Vince (Eds) *Frontiers of Human-Centred Computing, Online Communities and Virtual Environments*. Springer Verlag: Amsterdam, pp263-277, 2001
- [Rasmussen, 41] Rasmussen, D. I.: *Biotic Communities of Kaibab Plateau, Arizona*, Ecological Monographs, Vol. 11, No. 3, pp. 230-275, 1941
- [Richardson, 91] Richardson, G.P.: *Feedback Thought in Social Science & Systems Theory: In Social Science and Systems Theory (System Dynamics Series)*, Pegasus Communications, 1991
- [Riesman, 82] Riesman, D., Reuel, D., Glazer, N.: *The lonely crowd– A Study of the Changing American Character*, Yale University Press; Subsequent edition, 2001
- [Russ, 07] Russ, C.: *Online Crowds - Extraordinary mass behavior on the Internet*, In: *Proceedings of i-Media '07*, Graz, Austria, pp.65-76, October 2007
- [Russ, 08] Russ, C., Lux, M.: *A Model of Self-Organized Criticality in Emergent Web Systems*, to appear In: *Proc. 7<sup>th</sup> International Conference on Information Systems Technology and its Applications (ISTA 2008)*, Klagenfurt, Austria, April 2008
- [Sterman, 06] Sterman, J.D.: *Business Dynamics. Systems Thinking and Modeling for a Complex World*, Mcgraw-Hill Higher Education, 2006

## Dynamic Network Analysis of Wikis

Ralf Klamma, Christian Haasler

(RWTH Aachen University, Information Systems  
Ahornstr. 55, 52056 Aachen, Germany  
{klamma|haasler}@dbis.rwth-aachen.de)

**Abstract:** Wikis have their seeds in the easy collaborative editing and maintenance of web pages. This was picked up by tremendously successful public projects such as the online encyclopedia *Wikipedia*. Creating, modifying and maintaining of wiki articles implies social structures and dependencies between wiki authors and wiki articles themselves. The general challenge of this work is to consider these structures as dynamic evolving networks and to point out prominent behaviors in large wiki-based networks. We present an environment capable of handling data management, measurement and visualization issues for the dynamic network analysis of publicly available wiki data.

**Key Words:** Dynamic network analysis, wiki, Wikipedia, social networks, visualization, measurement, data management

**Category:** E.1, G.2.2, H.3.1, H.3.3, H.3.7, H.4

### 1 Introduction

Wikis and blogs are among the most successful social software platforms of the last years [Kumar et al., 2004, Vossen and Hagemann, 2007]. A whole industry has now been established around advancing wiki software, hosting wikis and offering added-value services. A variety of wiki projects are hosted on the *MediaWiki* engine, e.g. the most famous *Wikipedia*, an online encyclopedia with millions of entries in hundreds dozens of languages edited by a countless, non-paid crowd of editors. The enormous number of public and organizational wikis has created a long tail. Besides the very successful and very visible wiki-based knowledge creation and sharing projects, there are many others with much less editors and edits. These phenomena have drawn also a lot of scientific attention, e.g. [Vega-Redondo, 2007, Adler and de Alfaro, 2007, Kittur et al., 2007, Aronsson, 2002]. A lot of studies have already been performed to analyze wikis. One of the first comprehensive researches of Wikipedia was conducted in 2005 by J. Voß[Voss, 2005]. Wikipedia was measured [Barabási et al., 1999] to find out that the distribution of links behaves with respect to *growth* and *preferential attachment*. Wikipedia also revealed a scale-free character in its link structure. D. Wilkinson and B. Huberman figured out that the quality of an article highly depends on the number of its modifications. They demonstrated that the accretion of edits to an article is described by a simple stochastic mechanism, resulting in a heavy tail of highly visible articles with a large number of edits [Wilkinson and Huberman, 2007]. [Kittur et al., 2007] examined the success of

Wikipedia. In particular, they analyzed if it is a great number of contributors where each deals with only a few articles or if it is only a small elite group of contributors that has the lion's share. In spite of Wikipedia's equal treatment of editors, some members get a leading role [Reagle, 2007]. On this qualitative view on Wikipedia the work of [Priedhorsky et al., 2007] dealt with the creation and destruction of Wikipedia articles. The researchers quantified the influence of edits and revisions in relation to the visitors. Most astonishing, vandalized articles are only read by three readers in average before being repaired by the Wikipedia community. In general, those studies can be classified in studies which make use of the publicly available wiki data (dumps) themselves and in studies making use of additional data like access log files [Priedhorsky et al., 2007]. In this paper we concentrate on the analysis of publicly available wiki dumps. In this regards, we can further classify studies concentrating on the static analysis of wiki dumps [Voss, 2005, Hu et al., 2007] and those concentrating on the dynamic aspects. In this paper we concentrate on the dynamic analysis of wikis, especially dynamic network analysis (DNA).

DNA is an emerging area of science enriching traditional social network analysis [Carley, 2003] by the idea that networks evolve over time in terms of changes of nodes in the networks and changes of links between nodes. The kind of changes depends strongly on the network under enquiry. Why is DNA of any relevance for wikis? We argue that first, revealing prominent nodes within the network, "important" and "unimportant" nodes, centrality, hidden dependencies within networks, power laws, heterogeneity, distinct hierarchical structures, small distances etc. are not possible without any network analysis. But within this static view it is not possible to analyze growth, saturation and adjustment of networks. For wiki users, wiki managers, and wiki hosting services it is extremely important to know, if wikis are still going to grow in numbers of authors, edits and wiki articles or if the wiki is going into a phase of stagnation? When a node is "important" will it stay important over the lifetime of the wiki or will its importance change over time? If a network is heterogeneous will it become homogeneous after a while or will it by that way for ever? When it comes to the dynamic network analysis of wikis we investigate two different kind of nodes, authors and articles and two different kind of relations, author–author relations and article–article relations to answer questions like those stated above.

The rest of the paper is organized as follow. In Section 2 we characterize wikis as social networks where DNA is applicable. In Section 3 we are presenting the main results of our analysis of different wikis. We conclude our paper with a discussion and an outlook on further research.

## 2 Wikis as Social Networks

Social network analysis is concerned with patterns of relationships between social actors [Breiger, 2004]. In this manner, mediated relations between actors as in Wikis can be regarded as social networks. Authors as well as articles can be seen as actors in a social network which helps to achieve the aim of establishing the wiki. Relations between node pairs emerge while two authors are writing an article in common. These networks of different actors and relations naturally evolves through the wiki editing process. The most significant restriction of classical social network analysis (SNA) is the lack of dynamic components such as the growth and adjustment of the social network. Dynamic network analysis (DNA) considers acting and behaviour of the network objects during the evolution process. Thus, a time component will be added to the networks. We use now classical centrality measures as well as the Small World Phenomenon and the power law distribution in social networks, for details cf. to e.g. [Brandes and Erlebach, 2005].

As aforementioned two network models are set up. Thus the (undirected) author graph is defined as  $G_{author} = (V_{author}, E_{author})$ . A label consisting of the author name and type (*registered/anonymous*) is allocated to every node  $v \in V_{author}$ . Because the node labels are unique there won't be an explicit distinction between a node and its label below. Each edge  $e \in E_{author}$  represents a relation between two authors, i.e. the collaboration of them on a wiki article. So the connective edge can be understood semantically as that article on which both authors have cooperated the first time. In the (directed) article graph  $G_{article} = (V_{article}, E_{article})$  each node  $v \in V_{article}$  corresponds to a wiki article and its name space. E.g. the node for the Wikipedia discussion site of the article *Chemistry* is denoted by *Talk:Chemistry*. The directed edges of article graphs represent references/links from one article to another article or to external resources like websites. The references are contained in the text body of a wiki article. The evolution process of a wiki is journalized by means of revisions and special revision pages. Hence each modification of an article is reproducible via the corresponding revision. Each wiki possesses a sequence of timestamps  $TS$ . The smallest ("oldest") element of  $TS$  is that time stamp of the first article modification. It corresponds to the wiki generation. The greatest ("youngest") element corresponds to the last modification, i.e. the moment of the wiki dump creation. Author graphs as well as article graphs depend on timestamps  $t \in TS$ . By using timestamps it is possible to map the state of a wiki graph according to  $t$ . Consequently  $G_{article}(t)$  and  $G_{author}(t)$  represent the graph at time stamp  $t$ .

### 3 Dynamic Analysis of Wikis

Due to the space restrictions, we can only give some examples of hypotheses for the dynamic analysis of wikis we tested already with our system. If readers are interested in further analysis they can contact us or visit our system online, e.g. at <http://www.prolearn-academy.org>. We have developed a two-stage system prototype to handle all data management issues like data extraction from different wiki hosting platforms, transcription of wiki dumps into dynamic social network data sets reflecting dynamic author-author article-article dependencies, the dynamic analysis of network data, and last but not least the aesthetically appealing visualization of network data. In order to generate networks according to this goal a two-staged system was implemented. It consists of a software prototype that takes care of data extraction, transferring them into a system database, preparing them for generating and visualizing networks as well as applying measurement methods. Stage 1 is able to handle with XML dumps of arbitrary file size. Parsing is done in linear time and constant space using SAX. Stage 2 uses the advantages of graph tool kits and their network analysis methods and algorithms. The details of the design and the implementation are described in [Klamma and Haasler, 2008]. The developed system allows for analyzing the gained network data on different levels. On the database interface information can be filtered and prepared for further processing. There are two main aspects in the dynamic analysis of network data. Data can be classified in *network dimension data* and in *network structure data*. In general the dimension aspect refers to the size of the wiki networks and its changing during the evolution process. In author networks the considered characteristics may be the number of authors, the number of edits per author, and the corresponding rate of growth. In the article case network dimensions may refer to the number of links and its rate of change. The structural matter applies network measurements like centrality, shortest paths or clustering. Both the dimension and the structural aspect can be analyzed via the gained network information based on public data. Wiki log files or direct measurements at the wiki database are abandoned. In the following a couple of hypothesis concerning network characteristics are introduced. They will give at least some hints how wiki networks evolve and behave.

*The rate of new authors/articles into a wiki network falls off after a period of time.* The idea is to come from a “foundation fever” of a wiki. Figure 1 shows both the growth rate of the number of authors and articles. A few wikis are treated in the diagrams. In general, the assumption can not be verified. It couldn't determined a fall off in the rate of growth in both cases. The growth's characteristics may be up to semantic aspects of a wiki, e.g. up-to-date incidences that animate new users to write new articles. It has to be proved individually. In the case of *Wikia Search* it seems to be clear. In January 2008 it went online for public – observably in the sharp bend in both network types. The mea-

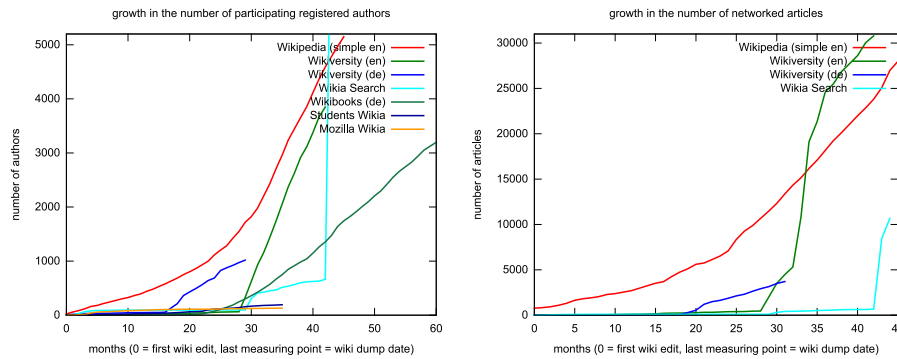

**Figure 1:** Rate of growth (author/article networks).

measurements of *Wikipedia (Simple English)* show a progressive growth rate, in the case of *Wikiversity* it fluctuates sometimes or it may have leaps and bounds in other wikis. Because Wikiversity’s articles are strongly categorised, further name spaces are included. There is a remarkable observation that wasn’t intended when considering both growth rates separately. Joining new authors to a wiki mostly means new articles – it does not mean working on already existing articles.

*Wiki networks are heterogeneous during the whole evolution process.* In homogeneous networks the number of  $k$  links per node is about the average  $\langle k \rangle$  [Albert et al., 2000]. Such a uniform distribution couldn’t be verified in (social) wiki networks. Applying and measuring the degree centrality showed an imbalance between the network nodes in terms of their links. According to a lot of situations in social structures a small portion of actors have above-average links and do most of the work, i.e. editing articles and establishing new relations. This is shown in figure 2 where two author networks are given (left, center). To make contact to other users, one needs to edit a lot of articles. But, this kind of users are the minority. This distinctive heterogeneity not only occurs in author networks, but also in article networks (see figure 2, right). For article networks this is proven in figure 3 by using the degree centrality. Incoming as well as outgoing article edges and links respectively are observed over a certain time period. The measurements showed in all considered wikis a continuous strong standard deviation of edges to nodes. Depending on semantic issues there may be a very high standard deviation of outgoing links. This is given in *Aachen Wiki* which serves as a information wiki for the city of Aachen and as an index which naturally has many outgoing references.

*Central nodes hold their important role during the evolution process.* As described, the “importance” of a node can be determined by using the betweenness



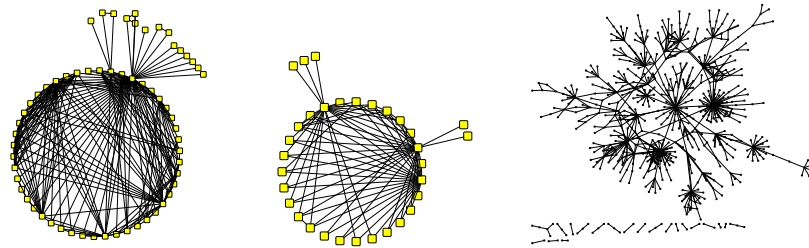

**Figure 2:** Heterogeneous author/article networks

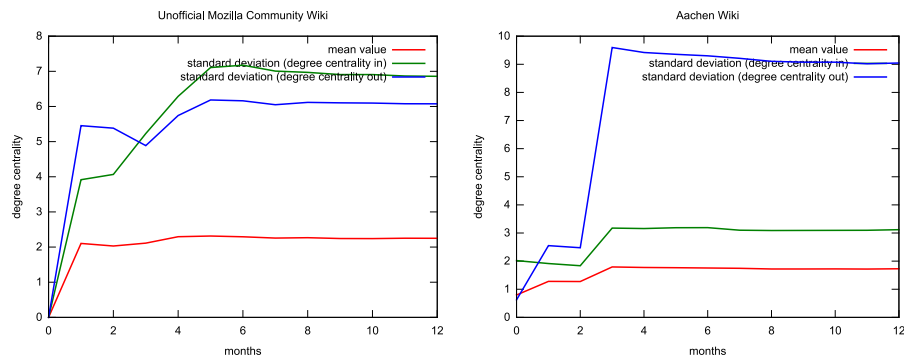

**Figure 3:** Article networks: degree centrality and standard deviation

centrality. This means that most shortest paths in the network go through these nodes. This measurement is done for *Wikia Search* for the time period August 2004 to August 2005. The left side of figure 4 gives for every registered author its betweenness centrality depending on time (unnormalized for a better view). Like the degree centrality there is only a small part of authors that have a high betweenness centrality. In general they hold or increase their high value during the evolution process. The survey can be found in article networks as well. The right side of figure 4 shows the betweenness centrality for *Jabber Wiki*, a wiki as the name suggests.

Important nodes can be found, too. Most central nodes keep their role during the process. The measure betweenness centrality also supports the assumption of heterogeneity of wiki networks. It shows both central authors and articles controlling the information flow in a wiki network. Author nodes with high centrality serve as intermediary of author relationships as well as they have a connection function of different author groups. Article nodes with a high index are visited often (above average) by “clicking” through the wiki.

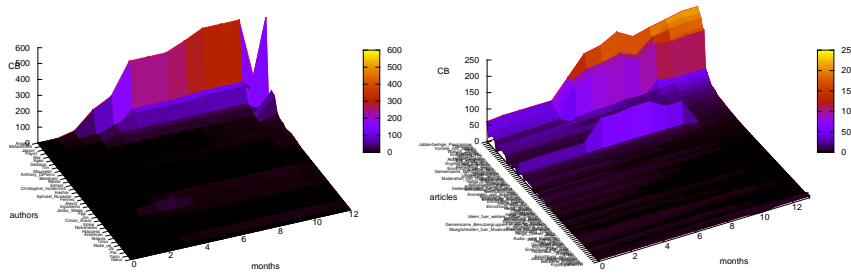

**Figure 4:** Betweenness centrality of author and article networks

#### 4 Conclusions and Outlook

Primary goal of this work was to establish a new view on wikis towards social networks and furthermore as continuous mutating and growing network structures. A deeper understanding of the network evolution and its dynamics was given by considering different kinds of quantitative and qualitative characteristics. Therefore, formal network models were established, regarding both network types author–author and article–article. To come up with the steady changing of networks a time component was added. The applied DNA refers to structural as well as to dimension aspects of wiki networks. One of the prominent characteristics gives the topology of both network types. Measurements of centrality indices revealed a growing heterogeneity in both cases. Like other social networks it could be determined a strong hierarchical structure of important and unimportant nodes. Furthermore, it could built a bridge to the Small World Phenomenon [Milgram, 1967, Watts and Strogatz, 1998] that can be found in social science frequently. It was shown a continuous growth in the number of authors and articles with a remarkable correlation. But there could not made a general assertion about the kind of growth. This has to be checked in any particular case. But, it offers interesting starting points for further research in cross-medial network types like author–article that contains author as well as article nodes. Beyond that research towards more semantic matters is interesting. What effect does weighting of edges have? What is the influence of *minor edits*? In addition, semantic analyses of corresponding discussions, talk or user pages in terms of growth and changing may be interesting, too.

#### Acknowledgements

This work was supported by the German National Science Foundation (DFG) within the collaborative research center SFB/FK 427 “Media and Cultural Communication”, within the research cluster established under the excellence initiative of the German government “Ultra High-Speed Mobile Information and Communication (UMIC)” and within the cluster project CONTICI. We thank our colleagues for the inspiring discussions.

## References

- [Kumar et al., 2004] Kumar, R., Novak, J., Raghavan, P., Tomkins, A.: Structure and Evolution of Blogspace.. *Communications of the ACM* 47(12) (2004) 35–39
- [Vossen and Hagemann, 2007] Vossen, G., Hagemann, S.: *Unleashing Web 2.0. - From Concepts to Creativity*. Morgan Kaufman, Burlington, MA (2007)
- [Vega-Redondo, 2007] Vega-Redondo, F.: *Complex Social Networks*. *Econometric Society Monographs*. Cambridge University Press, Cambridge (2007).
- [Adler and de Alfaro, 2007] Adler, B.T., de Alfaro, L.: A content-driven reputation system for the Wikipedai. In: *WWW (2007)* 261–270
- [Kittur et al., 2007] Kittur, A., Chi, E.H., Pendleton, B.A., Suh, B., Mytkowicz, T.: Power of the few vs. wisdom of the crowd: Wikipedia and the rise of the bourgeoisie. In: *25th Annual ACM Conference on Human Factors in Computing Systems (CHI 2007)*; 2007 April 28 - May 3; San Jose, CA. (2007)
- [Aronsson, 2002] Aronsson, L.: Operation of a large scale, general purpose wiki website: Experience from susning.nu's first nine months in service. In: *Proceedings of the 6th International ICC/IFIP Conference on Electronic Publishing, Karlovy Vary, Czech Republic, (2002)*, 27–37
- [Priedhorsky et al., 2007] Priedhorsky, R., Chen, J., Lam, S.T.K., Panciera, K., Terveen, L., Riedl, J.: Creating, destroying, and restoring value in wikipedia. In: *GROUP '07: Proceedings of the 2007 international ACM conference on Supporting group work*, New York, NY, USA, ACM (2007) 259–268
- [Voss, 2005] Voss, J.: Measuring wikipedia. In: *Proceedings of the 10th International Conference of the International Society for Scientometrics and Informetrics*. (2005)
- [Hu et al., 2007] Hu, M., Lim, E.P., Sun, A., Lauw, H.W., Vuong, B.Q.: Measuring article quality in wikipedia: models and evaluation. In: *CIKM '07: Proceedings of the sixteenth ACM conference on Conference on Information and Knowledge Management*, New York, NY, USA, ACM, 243-252
- [Carley, 2003] Carley, K.M.: Dynamic network analysis. In Breiger, R., Carley, K.M., eds.: *Summary of the NRC workshop on Social Network Modeling and Analysis*, National Research Council (2003)
- [Barabási et al., 1999] Barabási, A.L., Albert, R., Jeong, H.: Mean-field theory for scale-free random networks (1999)
- [Wilkinson and Huberman, 2007] Wilkinson, D.M., Huberman, B.A.: Assessing the value of cooperation in wikipedia (Feb 2007)
- [Reagle, 2007] Joseph M. Reagle, J.: Do as i do.: authorial leadership in wikipedia. In: *WikiSym '07: Proceedings of the 2007 international symposium on Wikis*, New York, NY, USA, ACM (2007) 143–156
- [Breiger, 2004] Breiger, R.L.: The analysis of social networks. In Hardy, M., Bryman, A., eds.: *Handbook of Data Analysis*. London, SAGE Publications (2004) 505–526
- [Brandes and Erlebach, 2005] Brandes, U., Erlebach, T.: Fundamentals. In Brandes, U., Erlebach, T., eds.: *Network Analysis: Methodological Foundations*. Springer (2005)
- [Klamma and Haasler, 2008] Klamma, R., Haasler, C.: Wikis as social networks: Evolution and dynamics. In: *Proceedings of 2nd ACM SNA-KDD Workshop at KDD 2008, August 24, 2008, Las Vegas, NV. (2008)*
- [Albert et al., 2000] Albert, R., Jeong, H., Barabási, A.L.: Error and attack tolerance of complex networks. *Nature* 406 (2000) 378–382
- [Milgram, 1967] Milgram, S.: The small-world problem. *Psychology Today* 1(1) (1967) 60–67
- [Watts and Strogatz, 1998] Watts, D.J., Strogatz, S.H.: Collective dynamics of 'small-world' networks. *Nature* 393 (1998) 440–442

## Getting to “Know” People on the Web 2.0

**Yiwei Cao, Anna Glukhova, Ralf Klamma, Zinayida Petrushyna**

(RWTH Aachen University, Ahornstr. 55, 52056 Aachen, Germany)

Databases & Information Systems

{cao|glukhova|klamma|petrushyna}@dbis.rwth-aachen.de

**Abstract:** Web 2.0 platforms such as media sharing and social network sites (SNS) concern people in everyday life to a great extent. People are enabled to reach out to various media and up to now, it is nearly impossible to use digital identities ex ante or to recreate users' identities ex post across different platforms. In this paper, we explore important methodologies in Web 2.0 such as cross-media analysis and social pattern based analysis based on a survey in this area, aiming at cross-platform information diffusion across social network sites. Open issues are discussed to explore the challenges and solutions in this new research area.

**Keywords:** social network analysis, Web 2.0, cross-platform, cross-media, Web services, identity management, XML, Semantic Web, Multimedia

**Categories:** H.5.1, H.3.5, H.3.3.

### 1 Introduction

Nowadays, media information sharing takes place rather on virtual social networks than in real life. Moreover, knowing people on the Web 2.0 is different from our experiences in real life. There are mere technical issues like different email addresses, different computers in the network, different account information in social platforms, different authorization methods like password based accounts or public key infrastructures and so on. In addition, social and psychological issues like preferred anonymity result in creation of many faked online identities or faked avatars etc. Furthermore, there are also commercial, security, and privacy issues like personal account data locked in vendor databases as a company asset, identity data kept on secure servers not shared with other sites and data protection laws preventing companies from sharing account information, even if users explicitly allow it.

Nevertheless, online reputation of people depends on their social capital, i.e. the closest neighbours, including knowledge about their favourite topics, their roles in the network, their behaviour, their mutual trust relation etc. Solutions to the requirements may not be novel. But it is challenging to deal with the technical, the socio-psychological, the legal, and the commercial issues at the same time. Here we concentrate on some aspects of things already available to sift the field.

The mechanics of social networks consider their members as actors of a community. Information sharing depends on the media we use. If we want to share private information, we normally do not use a public blog but an email. If we want to spread a message immediately, we post it in a frequently-read forum or tell it to a blabbermouth. In short, information diffusion aims to find media and people relevant to a particular piece of information. People's relevance is assessed by their knowledge

about the topic, by their position in the network, by their behaviour, by their mutual trust relations, etc. Hence, we propose the cross-media and social pattern-based analysis with social network analysis [Degenne and Forse 03] approach to realizing cross-platform information diffusion and to manage identities across social network sites in Web 2.0.

The rest of the paper is structured as follows. In Section 2 we give an overview of concrete solutions in cross-platform social networking. We introduce new methodologies and approaches related to research cross-platform social networking aspects in Section 3. The paper concludes with a short discussion.

## 2 What is already there in Cross-platform Social Networking?

Social network sites (SNS) emerge in recent years to enable users to create, search, share, and publish all kinds of information including not only diverse media content but also people's opinions and activities. Web 2.0 has become a kind of new culture with great social impacts. Virtual openness and reach out to communities feature Web 2.0 users. People can get to know people who they do not know in real life by reaching out to sharing information. Everybody is enabled online to share their ideas, videos, pictures, activities online. We compare people "know" people online and offline and find the comparison useful to understand identity issues well (cf. Table 1).

Activities	How to know people in reality?	How to know people the on Web 2.0?
Identity	name + social security id	User name + OpenID
Authentication	name + face	email address (user name) + password
Communication	handshaking, conversation, glance, seeing a film, meeting in a bar, visiting ...	Commenting, emailing, chatting, virtual discussions, emoticon
Knowing people in the networks	usually yes	yes or no (virtual friends)

Table 1: Differences on identifying people in real life and online

The prevalent SNS are shortly discussed as follows.

*Facebook* (<http://www.facebook.com>) as one of the most popular social network service has opened APIs also for third parties. Social network data is aggregated by news feeds to show recent activities within users' networks, such as who posts comments in whose profile, who tags whom in photos or who exchanges applications with whom.

*Flickr* (<http://www.flickr.com>) is a photo sharing platform that includes an explicit social network. This is exposed by the Flickr API exploring contact lists data and tagging activities.

*Del.icio.us* (<http://del.icio.us>) is a social bookmarking system which allows users saving, tagging, and describing links. In addition, an explicit social network can be established by adding interesting people into the list to see their bookmarks.

YouTube (<http://www.youtube.com>) is a video sharing web application allowing users collaborating around video files applying tagging and ranking. Users can manage a contact list to create an explicit social network.

The other prevalent SNS are presented as a summary in Table 2. The summary is done according to our observations of the presented data in SNS. Statistical analysis refers to media popularity, freshness. Semantic analysis is an extraction of data, community actors or media according to the interests, tags, and location etc. Structural analysis is performed on social patterns.

SNS	Shared information							Communication					Analysis				
	Photos	Videos	Music	Bookmarks	Stories	Contacts	Cross-media Activities	Activities	Ranking	Comments	Tagging	Forums	Friend's list	Emails	Statistical	Semantic	Structural
Del.icio.us				●		○	○	○			●		○		●		
YouTube		●				○	○	○	●	●	○	●	○		●	○	
Blogger	○	○	○		●	○	○	○		●	●						
Last.fm		○	●			○	○	○	○	○	●	○	○		●	○	
Facebook	●		○		●	○	○	●	○	●	●	●	●	●	●	○	●
LinkedIn						○	○	○	○				○	○			○
Twitter						○	○	●									
Mixx	○	○	○		○	○	○	○	○	●	●		○		●	○	●
Flickr	●	●				○	○	○		●	●		●	●	○		
FriendFeed	○	○	○	○	○	○	○	●		●	●		○				
○ - Though the feature is supported, it is not the focus of SNS; the support is poorly implemented, compared to the others																	
● - the feature is supported and SNS make an accent on it as one of the main features																	

Table 2: A summary to the comparison of Social Network Sites (SNS)

Content and systems interoperability is a main issue of information system nowadays. Web 2.0 technologies like RSS facilitate information sharing across different Web 2.0 platforms. In addition, cross-platforms have been realized by synchronization technologies between MSN Messenger and Windows Media Player, between Outlook/iCal with Google Calendar, and among Last.fm and Windows Media Player and iTunes. For example, socialization is performed by informing people what music their buddies are listening to. From viewpoint of social network platforms a single sign-in over different platforms is crucial for interoperability concept.

The cross-platform aspect is novel and emergent for social network information aggregation and diffusion. This aspect is well identified and covered in [Guy et al. 08]. SNS have a wide coverage of applications with diverse content created by users ranging from simple user contacts to multimedia. When a user is a novice to a social network site, he needs to register, login, create his/her user profile, and get his/her social network via email address books. Through recent booming acquisition of start-

up social network sites by the market leading companies, users are supported to single-login to some extent. However, the interoperability of social network information across SNS is still limited.

#### *The Friendfeed Approach to Social Aggregation*

Above all, *Friendfeed* ([www.friendfeed.com](http://www.friendfeed.com)) allows users aggregating 41 different SNS services including Flickr, Del.icio.us and YouTube. What happens within supported SNS can be well traced, so that users are able to monitor their buddies' activities correspondingly. Besides, Socialthing!, Spokeo, SecondBrain and Iminta are all the similar platforms like Friendfeed to serve as social aggregators for cross-platform information diffusion.

In conclusion, the Friendfeed approach makes a first successful step towards cross-platform information diffusion on Web 2.0. However, the information is passed within the friend network limited in SNS. Users could have partly different networks on different SNS, which are not taken into account totally. No SNS like MySpace or Facebook etc. which consists of many different and non-interoperable for each other services such as photo sharing, blogging, instant messaging and so on) can be aggregated. Only "homogenous" SNS services, that are built according to the same model and use standard services, can.

### **3 Conceptual Cross-Platform Information Diffusion**

According to the data presented in the last section, we propose four main aspects of cross platform information diffusion: social network analysis, cross-media, social pattern, and identity management. The existing approach is social aggregation of diverse SNS media including services and content created by user communities. We observe media and communities as a whole. Not only media is dealt with in a cross-platform manner, but also social networks need to be analysed across platforms. Hence, social pattern analysis as well as social network analysis needs to be employed to draw a social graph [Hinchcliffe 08b] on it (cf. Figure 1). Identity management is the key to fulfilling cross-platform information diffusion on cross-platform networks.

#### *Social Network Analysis Methodologies*

Social networks indicate a special kind of networks where social relationships are viewed as edges in graphs with values in a social context. The understanding of relationships between members, dependencies between networks and technologies, as well as semantic examination of networks and members identities study is complex tasks of social networks exploration. Within social networks, actors and their actions are viewed as interdependent rather than independent and autonomous units [Wasserman and Faust 94; Vega-Redondo 07]. Recently, there are much research and many available systems for finding relevant people [Lin et al. 08; Guy et al. 08]. In order to distinguish nodes within a network, SNA focuses on the study of in-degrees and out-degrees of a node, i.e. centrality measures. Nodes with the high degree centrality are the most visible in the network, adjacent to the members, and contribute to the identity of the network [Wasserman and Faust 94]. The betweenness centrality identifies how many paths are going through members, how many times they are

bridges of information. The Edge Betweenness Centrality (EBC) [Freeman et al. 91] is useful to identify network subgroups and to recognize social patterns.

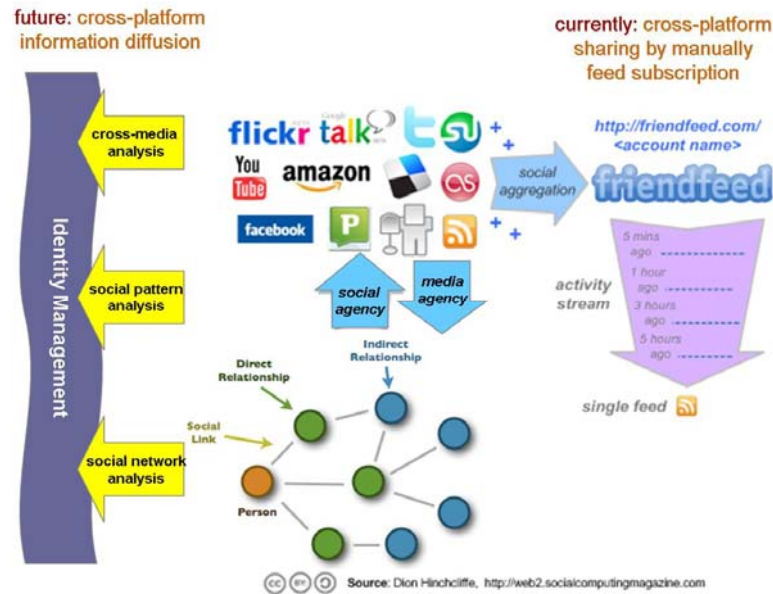

Figure 1: Cross platform for social network sites (adapted from [Hinchcliffe 08a; Hinchcliffe 08b])

#### Cross Media Analysis

We deal with social network data from different sources which are of a private (e.g. private SMS, private chat), a semi-public (e.g. mailing lists, group chats, forums, protected wikis) or a public nature (e.g. blogs, public wikis, public image or video sharing) [Klamma et al. 07]. Digital media make information easy to be copied and aggregated with little additional workload [Hogan 07]. The requirements on the combination of data from the media create the need of cross-media analysis application in the examinations of social networks.

Applying this we need network models that focus on individuals and consider the network structural environment as opportunities for or constraints on individual actions. Network models conceptualize social, economic, and political structures as lasting patterns of relations among actors. Among others, Actor Network Theory (ANT) [Latour 91] is appropriate for observing networks formed by humans and media, as it does not distinguish between human and non-human actor. ANT model reveals relations between technologies for social networks and identifies one prototype for all technologies and members of social networks in order to ease the comparison of influences of technologies and to alleviate the merge of social networks [Klamma et al. 06]. Furthermore, semantic analysis can be additionally applied besides cross-media approaches, with which social network data can be traced



back to the term of “semantic nets” as well as semantic networks based on graph theories [Shastri 91].

#### *Social Pattern Based Analysis*

Social patterns include similar behaviour of members over their social networks. The following social patterns are useful for cross-platform information diffusion. The members are *brokers*, when they transmit knowledge between sub-groups in networks [Kilduff and Tsai 06]. The brokers are usually those, who span *structural holes* that are the relationships between two non-redundant neighbours of the network [Burt 92]. The size of a member social capital, i.e. the closest neighbours of the member in a network, increases, if the number of structural holes he spans grows [Granovetter 73]. A broker is a bottleneck in the network and enjoys his/her power. He/she controls information flows between groups. Brokers are useful to spread information to non-relevant people. The members are *hubs*, when these have a relatively high number of relations with *authorities*. The members are the *authorities*, if many of the others have relations with them [Kleinberg 99]. Usually, there are many *hubs* and few *authorities* in the network. Such distribution over nodes indicates that the network is scale-free and obeys the power law [Barabási 03].

#### *Identity Management*

Microsoft Live ID and Google accounts first brought identity into sight. Concept of identities is of great importance in digital social networks [Neuenschwander et al. 05] and one of examples of its implementation is the standard of OpenID. The standard has been developed from a lightweight HTTP based URL authentication framework to an open community-driven platform [Recordon and Reed 06]. Started with 9 million users on LiveJournal.com for bloggers, more and more social network sites support OpenID. The most significant benefit is to enable single-login, so that users do not need to register with another set of username and password to a new service. Users' wish whether to use OpenID is specially mentioned in [Powell and Recordon 07], which leads to trust issues potentially. Users might question how safe it would be to sign in each social network sites to access personal mail box with the same user name and password. So far, OpenID is an efficient method to identify users across platforms. What will happen, if one's OpenID is once stolen? A personal identity repository can be established, if email addresses traced. However, these emails are not allowed to be used for further purpose. In short, security, privacy and trust are particularly critical.

## **4 Discussion and Conclusion**

In this paper we collected and analyzed some of the literature related to new approaches of analyzing and introducing social data across different platforms. We have argued that identification of right people and right media is essential to many new tasks in the social web like the effective and efficient diffusion of information. Because of our view that analysis is as important as operational support for cross-platform systems, we argued to identify people by a combination of pattern-based social network analysis giving us more insights in the social agency of people and cross-media analysis giving us the opportunity to gain knowledge out of the

embedding of agency in media. The other components that have to be taken into consideration in the future for the paper topic are the media types we are using for any task in SNS. These affect our behaviour and our position in a society. Technologies and their influences have to be included in the analysis of social network data as their competent members. Furthermore, the examination of Part-Of-Speech taggers in social network content and its emotions resolves ambiguity about the sense of content [Lakoff and Johnson 80; Pennebaker et al. 07]. Through all presented in the paper approaches, it is possible to reflect the social network data changes dynamically and to keep social network data processing up-to-date. Based on the research presented here, it is possible to develop new mechanisms for social network data collections and for developing new services for cross-platform information diffusion services.

## References

- [Barabási 03] Barabási, A.L.: “Linked: The New Science of Networks”, *J. Artificial Societies and Social Simulation*, 6(2), 2003.
- [Burt 92] Burt, R.: “Structural Holes: the Social Structure of Competition”, Harvard University Press, Massachusetts, 1992.
- [Degenne and Forse 03] Degenne, A., Forse, M.: “Introducing Social Networks, Sage Publications, 2003.
- [Freeman et al. 91] Freeman, L.C., Borgatti, S.P., White, D.R.: “Centrality in valued graphs: A measure of betweenness based on network flow”, *Social Network*, 13:141–154, 1991.
- [Guy et al. 08] Guy, I., Jacovi, M., Shahar, E., Meshulam, N., Soroka V., Farrell, S.: “Harvesting with SONAR- The Value of Aggregating Social Network Information”, *Proc. ACM Conference on Human Factors and Computer Resources, CHI’08*, Florence, Italy, 2008.
- [Granovetter 73] Granovetter, M.S.: “The Strength of the Weak Ties”, *American Journal of Sociology*, 78:1360–1380, 1973.
- [Hinchcliffe 08a] Hinchcliffe, D.: “Social Aggregators Emerge to Manage Digital Lifestyles”, *Dion Hinchcliffe’s Web 2.0 Blog*, March 19, 2008, <http://web2.socialcomputingmagazine.com/{12.04.2008}>.
- [Hinchcliffe 08b] Hinchcliffe, D.: “The Social Graphs: Issues and Strategies in 2008”, *Dion Hinchcliffe’s Web 2.0 Blog*, January 16, 2008, <http://web2.socialcomputingmagazine.com/{12.04.2008}>.
- [Hogan 07] Hogan, B.: “Using Information Networks to Study Social Behavior: An Appraisal”, *IEEE Data Eng. Bull.* 30(2): 6-14, 2007.
- [Kilduff and Tsai 06] Kilduff M., Tsai, W.: “Social Networks and Organizations”, SAGE Publications, London, Thousand Oaks, New Delhi, 2006.
- [Klamma et al. 06] Klamma, R., Spaniol, M., Cao, Y., Jarke, Y.: “Pattern-based cross media social network analysis for technology enhanced learning in Europe”, Nejd, W., (eds): *Innovative approaches for learning and knowledge sharing: Proceedings of First European Conference on Technology Enhanced Learning, EC-TEL 2006*, Crete, Greece, October 1-4, 2006, Berlin: Springer, 2006 (LNCS 4227), 242-256.
- [Klamma et al. 07] Klamma, R., Cao Y., Spaniol, M.: “Watching the Blogosphere: Knowledge Sharing in the Web 2.0”, Nicolov, N., Glance, N., Adar, E., Hurst, M., Liberman, M., Martin,

- J.H., Salvetti, F., (eds): International Conference on Weblogs and Social Media, Boulder, Colorado, USA, March 26-28, 2007, 105-112.
- [Kleinberg 99] Kleinberg, J.: "Authoritative Sources in a Hyperlinked Environment", J. ACM, 49:604–632, 1999.
- [Latour 91] Latour, B.: "Technology is Society Made Durable", Law, J., (eds): A Sociology of Monsters: Essays on Power, Technology and Domination, London: Routledge:103–31, 1991.
- [Lakoff and Johnson 80] Lakoff, G., Johnson, M.: "Metaphors We Live By", Chicago: University of Chicago Press, 1980.
- [Lin et al. 08] Lin, C.-Y., Ehrlich, K., Griffiths-Fisher, V., Desforges, C.: "SmallBlue: People Mining for Expertise Search MultiMedia", 15(1):78-84, January-March, 2008.
- [Neuenschwander et al. 05] Neuenschwander, M., Lewis J., Blum, D.: "Enterprise Identity Management: Moving from Theory to Practice", Burton Group, Identity and Privacy Strategies, In-Depth Research Overview, June, 2005.
- [Pennebaker et al. 07] Pennebaker, J.W., Chung, C.K. Ireland, M., Gonzales, A., Booth, R.J.: "The Development and Psychometric Properties of LIWC2007", LIWC Inc, Austin, Texas 78703 USA in conjunction with the LIWC2007 software program, <http://www.liwc.net/LIWC2007LanguageManual.pdf> {10.04.2008}.
- [Powell and Recordon 07] Powell A., Recordon, D.: "OpenID: Decentralised Single Sign-on for the Web", Ariadne issue 51, April 30, 2007, <http://www.ariadne.ac.uk/issue51/powell-recordon/> {10.04.2008}.
- [Recordon and Reed 06] Recordon D., Reed, D.: OpenID 2.0: "A platform for user-centric identity management", Proceedings of the second ACM workshop on Digital identity management, Alexandria, Virginia, USA, ACM Press, 11-16, 2006.
- [Shastri 91] Shastri, L.: "Why semantic networks?", Sowa, J.F. (eds): Principles of Semantic Networks, Morgan Kaufmann Publishers, inc., 1991.
- [Vega-Redondo 07] Vega-Redondo, F.: "Complex Social Networks", Cambridge University Press, 2007.
- [Wasserman and Faust 94] Wasserman S., Faust, K.: "Social Network Analysis", Cambridge University Press, 1994.

# **Knowledge Sharing with Social Software - Wikis in Human Services**

**Klaus Bredl**

(University of Applied Sciences, Neubrandenburg, Germany  
bredl@hs-nb.de)

**Abstract:** The need for Knowledge Management (KM) in Human Services is growing. New “Social Software”-solutions which came along with the so-called “Web 2.0” enable advanced possibilities of implementing KM-strategies in smaller agencies in the domain of Social Work. In the field of human service-oriented knowledge sharing one case out of three projects showing the use of a wiki will be presented. The project deal with the introduction of a wiki in the area of Case Management in a job center.

**Keywords:** Social Software, Wiki, Web 2.0, Human Services, Knowledge Management, Open Source

**Categories:** H.1.1, M.5, M.6, L.1.0

## **1 Introduction**

The organization of knowledge is diverse in public Human Service Agencies confronted with private companies or domains. Knowledge Management is especially necessary in Social Work, since human service occupations inherently consist of knowledge-based work. Social Work comprises individually-related services in which the single social worker, with his/her knowledge is the key factor for value creation. [Cha et al 06]. A problem occurs when knowledge (e.g. generated in pilot projects) cannot be properly transferred into routine social work.

The utilization of knowledge in Human Services is for conceptual and instrumental purposes and is holistic and contextual rather than abstract, fixed and representative [Dustin 06]. In the practice of Social Work, some knowledge is canonical. This includes knowledge about available forms of help as well as legal services to provide clients with the assistance they are entitled to within their rights. Though regulations are modelled in the specialized Information Systems, practitioners “have problems when applications contain only information because knowledge is needed to support many worker decisions” [Schoech 99]. Because most expert knowledge is often tightly connected with know-how given that the subject of social work is often the support of everyday life, it is difficult to identify declarative knowledge that experts unanimously can agree upon. Empirical evidence suggests that the acquisition of experience-based knowledge might be different in social work compared to well-structured domains like medicine [Boshuizen & Schmidt 92b; Gruber 1999].

Tacit knowledge [Polanyi 66] is often stored in our minds and is not easily available. Tacit knowledge can be regarded as encapsulated expert knowledge [Boshuizen et al. 1992a] and is difficult therefore to pass on, particularly to novices.

If we regard the domain of Social Work and think about the various services for help, counseling and therapy, we could come to the assumption that the implicit part of the knowledge-iceberg which is under the water seems much bigger in this ill-defined domain as it is in well-defined other ones [Bredl 08]. In order to get an idea of this issue we should think about questions like: How to counsel? How to help? Comparable questions on economic or industrial services seem much more explicable or standardized like: How to produce? How to serve?

Around the dimensions in the HOT-model which is divided in the areas of Human, Organization and Technology based upon the TOH model of Bullinger, Wörner & Prieto [98] you can find many problems and barriers for Knowledge Sharing [Maier 07]. The problem in the area of human services is not only the overbalance of implicit knowledge but also that until now the management of social agencies do not care enough about knowledge management. Respectively, they think knowledge management is combined with an unaffordable complicated technical system. So until now, no major priority to this field of management has not been seen though it is obvious that combined with each social business process parallels a knowledge process [Remus & Maier 03]. But obviously there is a change in view. Because of the rising competition in the social field and the human service sector the focus is changing, consequently the need for knowledge will shift [Kreidenweis & Steincke, 06].

The classification of two main strategies of Knowledge Management, codification and personalization of knowledge [Hansen et al. 99] can be continued to the KM-Instruments. Therefore, interactive and integrative instruments can be differentiated. Integrative KM-Instruments regard knowledge as an object and offer functions to store and administrate explicit knowledge in systems. In contrast, interactive instruments support primarily the knowledge exchange between persons and are rather geared to implicit knowledge [Zack 99].

## **2 Social Software for Social Services**

### **2.1 The principles of Social Software**

Until now, high costs have prevented Human Services from the introduction of technology for Knowledge Management. A cheaper alternative choice is a Social Software solution which could be easily implemented and which is mostly based on Open Source [Hüttenegger 06].

What is Social Software? Do these kinds of applications, which are called “social”, have something to do with our social field, with the Human Services?

Social Software comprises web-based applications, which support the exchange of information and knowledge, the building of communities and the communication in a social context. Above all, Social Software, in contrast to traditional Knowledge Management Systems seems to require less investments. Firstly, this software installation is low-cost and secondly, due to the ease of use, there should be a reduction of laborious introduction and training efforts of the users. But Social

Software is also oriented on specific principles [Hippner 06; Schmidt 06]. The main management supporting functions of Social Software are covered by the Crystal-(Xtal-) Model [Bredl 07]. The support of four management dimensions focuses on: Communication Management; (Virtual-/Real-) Identity Management; Community Management; Information and Knowledge Management

The first and most important one is the support of communication processes which is technically realized through Web forums and Weblogs (Blogs). In a classic Information Management approach Groupware as a communication supporting instrument can be mentioned. The dimension of Communication Management is located in the strategy of personalization.

Identity Management, not to be mistaken with the term connected to IT-Security, focuses on dealing with the concept of one or more identities in Digital Social Networks and the expectable developing Virtual 3D-Worlds which will be used also in a professional corporate setting for the exchange of information and knowledge. So it is also a function of personalization.

More and more Digital Social Networks enable a powerful establishing of Communities of Practice. Therefore, the Management of Communities and Networks is necessary. This is also an important function within the strategy of personalization.

The fourth dimension is the Content and Information Management which aims at the single static parts of information in the Knowledge Management process and supports the strategy of codification.

We still have to do a lot of research on the use of these new “Social Software” solutions. The incentives for the social workers’ participation and the processes of implementation in the human services are of special interest.

Wikis provide many possibilities for teams that want to change their organization and processes and favour a participative and collaborative approach to their knowledge-based work and helping processes. For example, the requirements for an in-house training might be produced collaboratively on some versions of wiki pages [Ward 06].

## **2.2 Wikis as an Instrument for Knowledge Exchange in Human Services**

Wikis are adaptive systems which are determined by four notions: connectivity, adaptivity, self-organization and constructivism [Hippner 06]. Connectivity means links, cross references and interdependencies within the content of wikis. Adaptivity stands for flexibility, adaptation of information to the organizational change. Self-organization causes the development of patterns of information. The development of a common knowledge base is a constructivistic act by combining the different knowledge bases of the Wiki-Users. Wikis are extensible accumulations of text-based Web-Pages which are linked among each other. These web-based applications allow all users not only to observe but also to edit content of Wiki-Pages [Ebersbach et al. 05]. The founders of the first Wikis Bo Leuf and Ward Cunningham describe a Wiki as a communicative software tool, which supports and carries the discussion and the collaboration of several users [Leuf & Cunningham 01]. Wikis act as Knowledge Management instruments which could be regarded as open web-based Content Management Systems. Many of the various wiki-engines underlie the General Public License (GPL), whereby they are available as “free” software.

### **3 Case Study for the use of Wikis in Human Services**

#### **3.1 Motivation and Environment of the Case Study**

The case is chosen out of three corporate wikis in different developmental stages for supporting the knowledge exchange in an employment center, a Youth Welfare Agency which consists of 70 various locally independent welfare service units with 2600 employees and the “Socialpedia”, which was meant to become a knowledge platform for interested practitioners, but also for teachers and researchers of Social Work in Germany. The case presented in this paper shows the adoption of a wiki in a job center to enable knowledge sharing in a formal work setting.

The infrastructure, processes, implementation and potential benefits as well as challenges will be contemplated.

#### **3.2 Case Study**

##### **Infrastructure and requirements**

The organization is a small institution with approximately 200 employees divided in five agencies. The five sites are connected by a WAN with a leased line. The servers are located at the headquarter based on Citrix-Server4. The sites frame with Local-Area-Networks (LAN) individual intranets. The workplaces are provided with Thin Clients and Desktop-Workstations. The internet access works via the headquarter. External IT-administration and projects have access over VPN. The Overall Operating System is Windows XP, the utilized software is Microsoft Office and the e-mail-exchange is operated by Microsoft Outlook.

The data filing storage is via drive G:// accessible for all members of the single site. It is possible to store files individually in the Operation Systems in “My Folders” or in Microsoft Outlook.

The used Information and Documentation System (IS) LÄMMkom was introduced in 2004 and since then partially fixed with patches. The IS supports integrative procedures of the modules Administration, Benefits/Payments, Case Management and endorse the placement of clients in the first and second job market. This Case-Management-System provides less KM functionality and is focused only on administrative processes.

The „JobNetzwerk“ is a web-based application for the employment service in the first labor market which is still at a test stage.

The Trouble Ticket System (TTS) is a software to handle the reception, confirmation, classification and processing of client requests (Trouble Tickets). The TTS runs on an Apache webserver. The corresponding Open Source software is ORTS. For security reasons the different access authorizations for the systems are not handled by Single Sign-On [Schrader 07].

##### **Previous Knowledge Sharing**

Despite of the existing technical systems the knowledge-exchange occurs mainly in discussion groups. The case managers regularly discuss their experiences with the cases and e.g. the implications of new legal situations. Protocols of the meetings' content are always prepared.

The structure of the sessions looks like:

In the Headquarter: Divisional head with agency heads; Meetings of team leaders division benefits; Meetings of team leaders division Case Management

Within the agencies: Staff Member benefits with Team Leader benefits; Case Manager with Team Leader Case Management

The need for knowledge dissemination was primarily in the field of the granting of supplementary benefits which are subject to individual interpretation of legal rules. The case manager also has to provide social work-based supporting measures and to find the right job offers for the client. The staff searches for generalized case reports and network information about the regional job market.

### **Implementation**

The described Wiki is called the “SozAgWiki” and should serve as an internal Wiki-Knowledge-Base and for the knowledge exchange of the Case-Manager in a job center about best practice cases and lessons learned by helping people to return to the labor market. Before the launch of the new wiki-based system for the support of Knowledge Management within the agencies, there was a discussion group to clarify how to work with the wiki. The question was whether by directive or by the Web 2.0 Wiki-voluntary principle. As no real decision was made, it went more or less to a voluntarily-based solution.

Motivation techniques were introduced by E-Mail to increase the staff’s use of the wiki:

1. Direct information of the staff by E-Mail about the functionality and the advantages of the new wiki.
2. Pointed action: E-Mail link to a gag combined with the wiki-page-link  
This little campaign caused a considerable increase of the wiki-access within six hours as 80 hits were counted.
3. Pointed information offer – menu of the canteen
4. Staff members were addressed directly by e-mail to put information in the wiki. The page had already been created before and the mail contained the page link.

“Good morning R., please put your information and comments about your course of instruction in our wiki. You find the page under <http://.....>  
Thank You!”

### **Lessons Learned**

The reactions were diverse. Especially the younger staff members worked actively with the wiki because they were very interested in it. But predominantly the staff only satisfied the demands for the collaboration with the wiki, in the long term the majority of the staff lacked a continuous support of the wiki-project.

A formative evaluation accomplished by interviews with two participants in the wiki-project is shown below:



**First interview****-Overview:**

*“In my opinion there is a lack of: Relevant court decisions, Examples of good assessment notices, Guidelines, work tools, Materials of further trainings”*

**-Structure**

*“I think we should reflect again on the structure of the wiki knowledge base. Moreover, the alphabetical index should contain folders. For me it is a big mixture. Names beside keywords, briefings next to manuals. From my point of view there should be more folders and subfolders: Agency x/Head/Staff Members; Service regulations with several subfolders; Assessment notices grouped by subjects: refusals, partially approved, approved”*

**Second Interview****-Overview:**

*Advantages: Correction and actualisation of text.*

**-Structure**

*“Initial problems concerning the orientation on the home page are secondary, whereas the retrieval of information is no problem. And the automatic index of content is very helpful. The function of editing is not so easy. Some colleagues do not have enough time for using the wiki actively.*

*The deposited documents are not refillable. The creation and editing of pages should only be possible for registered users. So the modifications could be traceable.”*

**4 Conclusions**

The example presented above represent the possibility of implementing a knowledge base for social agencies with restricted resources. In the case, only a few members of the organization have to be involved with the development. Consequently, less effort is required and basic ICT infrastructure is sufficient supporting KM. The fact that the KM project in the human service agency started with a core group and one person who designed the wiki structure, positively contributed to the first success of that initiative. Fast advances could be shown in some selected knowledge-intensive help processes. Still, because the SozAGWiki is focused too strongly on codification, they neglect the potential benefits of interactive instruments, such as blogs and communities like a social network. A solution could be an integrative system with combined various Social software components.

The problem was, that the organization was too small for a significant growth of the wiki-knowledge-base. The attempt to interlink the SozAgWiki with the other 69 similarly organised job centers throughout Germany failed because of accessibility and technical reasons. But the SozAgWiki is still in use for special documentation tasks in the relevant agency.

To make the wiki available for the staff and to advise them to use it from now on as the most important source of information and knowledge could cause some problems. It seems difficult, that an unstructured wiki is able to serve as a tool for all required knowledge sharing purposes. So it is explicable that the organisational information of the clients might still be stored in a separate information system.

## 5 Future Work

Social Software for KM is the combination of human and technology-oriented KM instruments and systems. Moreover, an information system like a wiki is a bottom-up instrument and enables processes of the democratization of the organization. As we have seen, technology cannot by itself change organizational culture. The kind of participation on which wikis and other Social Software applications rely “depends upon an existing corporate culture in which individuals feel free from possible repercussions for the information they contribute“ [Tredinnick 06]. According to Ward [06], there are a variety of tips to succeed in the implementation of a wiki in human services organizations:

1. Start small and work with just one group which is enthusiastic and committed to monitoring their experience and giving feedback.
2. Identify, understand and involve key users as soon as possible to develop a sense of shared ownership.
3. Some initial categories of content should be provided beforehand. Members will often require encouragement to begin to utilize the site. In the early phase, it will be helpful to prompt people to respond to relevant discussions posted on the site.
5. Base the selection of software on dependency of the service needs and uses. A Wiki is not the solution for all the problems of Knowledge Management. Don't call it “Wiki-project”- call it “New Information System”.
6. Evaluation of the implementation of Social Software is important. The Measurement of use and acceptance of the applications are vital.

Successful implementation is connected with the steering and monitoring of a given project. To place a wiki only to the disposal of staff is not enough. In this case, McLuhan [64] was not right, i.e. “The Medium is [not] the message”.

## References

- [Boshuizen et al 92a] Boshuizen, H. P. A., Hobus, P. P. M., Custers, E. J. F. M. & Schmidt, H. G.: Cognitive Effects of Practical Experience, Berlin, Springer, 1992
- [Boshuizen and Schmidt 92b] Boshuizen, H. P. A. & Schmidt, H. G.: On the role of biomedical knowledge in clinical reasoning by experts, intermediates and novices, In Cognitive Science, 16, 153-184, 1992
- [Bredl 07] Bredl, K.: Knowledge Management with Web 2.0 applications in Human Services, Poster presented for the conference: “The 8th International Conference of Human Services Information Technology Applications HUSITA”, August 26th - 29<sup>th</sup>, Toronto, Canada, 2007
- [Bredl 08] Bredl, K.: Kompetenz von Beratern. Analyse des Kompetenzerwerbs bei Unternehmensberatern im Kontext der Expertiseforschung, Saarbrücken, vdm, 2008
- [Bullinger et al 98] Bullinger, H.-J., Wörner, K., & Prieto, J.: Wissensmanagement-Modelle und Strategien für die Praxis. In H. D. Bürgel (ed.). Wissensmanagement. Schritte zum intelligenten Unternehmen, 21-39, Berlin, Springer, 1998
- [Cha et al 06] Cha, T., Kuo, E., & March, J.: Useful Knowledge for Social Work Practice. Social Work & Society, 4 (1), 111-122, 2006

- [Ebersbach et al 05] Ebersbach, A., Glaser, M., & Heigl, R.: Wiki Tools, Berlin, Springer, 2005
- [Gruber 99] Gruber, H.: Erfahrung als Grundlage kompetenten Handelns, Bern, Huber, 1999
- [Hansen et al 99] Hansen, M. T., Noria, N., & Tierney, T.: What's your strategy for Managing Knowledge? Harvard Business Review, 77 (2), 106-116, 1999
- [Hippner 06] Hippner, H.: Bedeutung, Anwendungen und Einsatzpotentiale von Social Software, In K. Hildebrand & J. Hofmann (Eds.). Social Software, HMD Praxis der Wirtschaftsinformatik, 252, 6-16, Heidelberg, dpunkt.verlag, 2006
- [Hüttenegger 06] Hüttenegger, G.: Open Source Knowledge Management. Berlin, Springer, 2006
- [Kreidenweis & Steincke 06] Kreidenweis, H. & Steincke, W.: Wissensmanagement, Baden-Baden, Nomos, 2006
- [Leuf & Cunningham 01] Leuf, B. & Cunningham, W.: The Wiki Way: Quick Collaboration on the Web, Boston, Addison-Wesley, 2001
- [Dustin 06] Dustin, D.: Skills and Knowledge Needed to Practise as a Care Manager: Continuity and Change, In Journal of Social Work, 6 (3), 293-313, Retrieved April 28, 2008, from <http://jsw.sagepub.com/cgi/reprint/6/3/293>, 2006
- [Maier 07] Maier, R.: Knowledge Management Systems. Information and Communication Technologies for Knowledge Management (3rd ed.), Berlin, Springer, 2007
- [McLuhan 64] McLuhan, M.: Understanding Media: The Extensions of Man, New York, Mentor, 1964
- [Polanyi 66] Polanyi, M.: The Tacit Dimension. London, Routledge and Kegan Paul, 1966
- [Remus & Maier 03] Remus, U. & Maier, R. (2003): Implementing process-oriented knowledge management strategies, Journal of Knowledge Management, 7 (4), 62-74, 2003
- [Schmidt 06] Schmidt, J.: Weblogs. Eine kommunikationssoziologische Studie, Konstanz, UVK, 2006
- [Schoech 99] Schoech, D.: Human Services Technology: Understanding, Designing, and Implementing Computer and Internet Applications in the Social Services, New York: Haworth, 1999
- [Schrader 07] Schrader, A.: Möglichkeiten ausgewählter Open Source – Software zur Unterstützung des Wissensmanagement in einer Optionskommune nach dem Zweiten Sozialgesetzbuch SGB II, Diploma thesis, University of Applied Sciences Neubrandenburg, 2007
- [Tredinnick 06] Tredinnick, L.: Web 2.0 and Business: A pointer to the intranets of the future? In Business Information Review, 23 (4), 228–234, 2006
- [Ward 06] Ward, R.: Blogs and wikis: A personal journey. In Business Information Review, 23 (4), 235–240, 2006
- [Zack 99] Zack, M. H.: Developing a Knowledge Strategy. In California Management Review, 41 (3), 45-58, 1999

## **Web 2.0 Adoption by Danish Newspapers - Urgent Need for New Business Models?**

Niels Bjørn-Andersen

(Centre for Applied ICT, CBS, Copenhagen, Denmark  
nba.caict@cbs.dk)

Leif Bloch Rasmussen

(Centre for Applied ICT, CBS, Copenhagen, Denmark  
lbr.caict@cbs.dk)

Soley Rasmussen

(Centre for Applied ICT, CBS, Copenhagen, Denmark  
sr.caict@cbs.dk)

**Abstract:** This paper presents findings from the development process of a general innovation framework for an ongoing Nordic R&D project on e-business and media. It focuses on the current state of the Danish news media sector and the conclusions we can draw from the “Web 2.0 activity” of the Danish newspapers. The paper concludes that the Web 2.0 offers the opportunity for fundamental re-thinking of the business models of the news media sector and for developing a new framework for business modelling for this sector.

**Key Words:** Web 2.0, Wikinomics, New Media, Social Media, Newspapers, Business Models

**Categories:** H.4.2., K.4.4., L.6.1

### **1 Introduction**

This paper is work in progress and part of a Nordic R&D project on e-business and media supported by the Nordic Innovation Centre. The objective of this project is to identify, evaluate and develop new innovative service forms and products for Nordic service providers and new innovative software and hardware for these e-business and media products.

At the Centre for Applied ICT at the Copenhagen Business School we have developed the general framework for innovation for the project and currently we are working on a pilot study for developing new business models together with a large Danish media vendor. This pilot study focuses on the news market.

In the first section we present a survey of the “Web 2.0 activity” of traditional Danish news media. This gives rise to the question whether there is a need for development of radically new business models in the media sector. In affirmation of this we finally propose an ontology for business modelling that could support this development.

## 2 Survey of Web 2.0 adoption by Danish news media

The phrase Web 2.0 was coined at a conference at O'Reilly Media in 2004 and hints at an improved form of the World Wide Web. While Web 1.0 sites were mere information silos, the “upgraded” 2.0 Web enables interactive content generation by the utilization of technologies for many-to-many publishing (e.g. blogs, wikis, RSS Feeds etc.), social/collaborative software for data sharing (e.g. Facebook, YouTube or Flickr) and open source standards/source code sharing. O'Reilly Media associates different technologies, services and phenomenon with the term, see fig. 1.

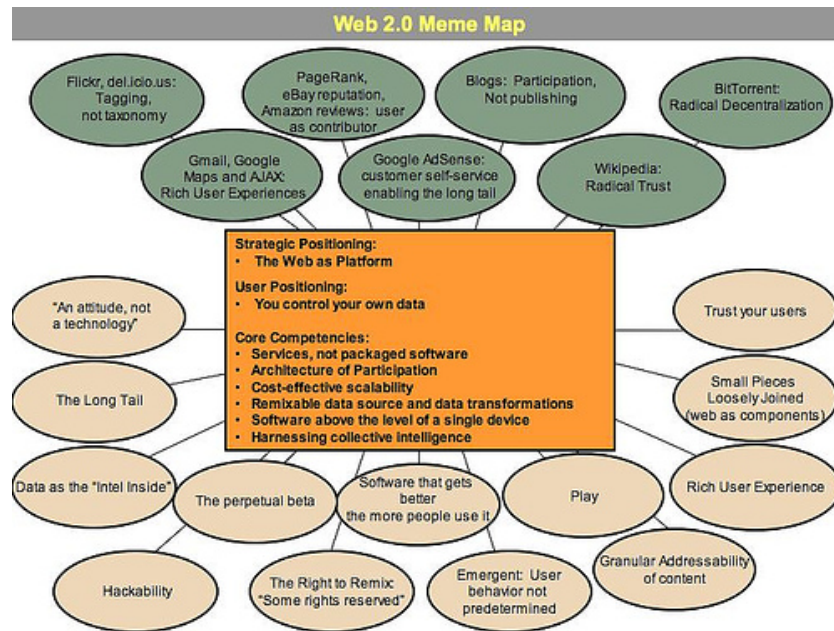

Figure 1: Meme map of Web 2.0 [O'Reilly, 2005]

To establish a better understanding of the impact of Web 2.0 on the media sector, we have done a survey of the adoption of Web 2.0 technologies and services by traditional Danish news media. Because the Web 2.0 umbrella embraces both technologies and services these will be referred to as ‘features’ in the following. Under the Web 2.0 umbrella we include new methods for delivery, participation and sharing, shopping, search, Web TV, and semantic/affiliated micro ads such as GoogleAds, see Table 1. These categories were developed during the process of the survey and thus, if a new feature was discovered, the categories were changed. The result are categories that frame different aspects of the Web 2.0 umbrella. A number of other features that could be included under the Web 2.0 umbrella are so widely or so little adopted, that we have chosen to list them separately, see Table 2.

The news media in the survey are the websites of all the Danish newspapers with national coverage, plus the three business news sub-sites (epn.dk, business.dk,

erhvervsbladet.dk) that are part of the two large media houses (JP/Politikens Hus and Berlingske Officin). All sites are categorised by affiliation to the parent organisation, those which are not part of a larger media house are categorised as independent. The total number of sites in the survey is 16, including the websites of five traditional morning news papers (Jyllands-Posten (JP), Politiken, Berlingske, Information, Kristeligt Dagblad (KrD)), one business morning paper (Børsen), one weekly paper (Weekendavisen), two tabloids (B.T., Ekstra Bladet (EB)), four free daily papers (24timer, Urban, metroXpress, Nyhedsavisen (Avisen)).

	Delivery					Participation/sharing							Shopping				Search			TV	Ads		
	Delivery (pdf)	Newsletter	RSS	Mobile feed	Podcast	Blog	Comments/Debate	Tips/sharing	Bookmark	Vote/your opinion	Photo/video/Flash (+ sharing)	Competitions	Games (free pay)	Pay per tips	Mobile PC (download)	Weblogs (music, films, books, travels)	Tickets (cultural events)	Jobs, addresses, cultural events etc.	Travels (info)	Deling	Web TV	Semantic/linked (Google, Sensei)	
JP/Politiken	JP.dk	x	x	x	x					x			x		x			x	x		x		
	epn.dk		x	x	x																	x	
	Politiken.dk	x	x	x	x		x	x		x		x	x			x	x	x	x			x	
	EB.dk	x		x	x		x	x	x		x		x	x	x	x	x	x	x	x		x	
	24timer.dk	x					x	x	x			x		**		x							
Berlingske Officin	Berlingske.dk	x	x	x			x	x	x	x	x					x	x		x	x		x	
	business.dk		x	x			*	*		x												x	
	erhvervsbladet.dk		x	x			*	*		x												x	
	BT.dk		x	x			x	x	x	x	x	x			x	x			x	x	x	x	x
	Urban.dk	x		x		x				x	x		x		x	x			x	x			
Independent	Weekendavisen.dk																						
	Information.dk		x				*	x														x	
	KrD.dk	x	x	x			x	x		x						x				x			
	Avisen.dk	x		x			x	x															x
	Metroxpress.dk			x				x			x			**		x	x		x				x
Børsen.dk	x	x	x	x	x							x										x	
<b>Total</b>	<b>16</b>	<b>9</b>	<b>10</b>	<b>13</b>	<b>5</b>	<b>2</b>	<b>11</b>	<b>11</b>	<b>4</b>	<b>1</b>	<b>9</b>	<b>5</b>	<b>5</b>	<b>6</b>	<b>3</b>	<b>4</b>	<b>8</b>	<b>3</b>	<b>13</b>	<b>6</b>	<b>3</b>	<b>10</b>	<b>3</b>

\*journalist blogs with user comments \*\* gifts, not cash

Table 1: Web 2.0 features on Danish newspapers' websites, Feb. 2008.

As shown in Table 1 all except one of the sites in the survey offers some of the features that we have included under the Web 2.0 umbrella. RSS feeds and newsletters are the most common features and some sites also offer other forms of personal delivery such as podcasts and feeds for mobile telephone platforms. JP.dk offers the most advanced delivery service with the JP2beta, an electronic edition of the paper that updates itself whenever the user is online. Most sites allow users to participate by commenting and blogging and other interaction features such as votes, competitions and tips are also common. A few sites even offer to “pay” for tips and other user input, e.g. user profiles and links. Avisen.dk incites pro-am-journalism explicitly.

Most sites have intensive use of photo, video, sound and Flash journalism and many allow users to share visual/audio content. Most sites display WebTV. Berlingske.dk has the most user-friendly bookmark and sharing system, allowing the user to share different kinds of content using a simple, single interface. Some sites offer free games and other entertainment freeloards. Most sites include free search options for jobs, shopping, travels etc. Most offer some kind of payload and/or retail shopping (music, films, gadgets, tickets, books etc.) or links to partnering sites that offer such services. A few display ads by Google and one displays Ad Pepper Media's semantic iSense ads (MetroXpress). Figure 2 gives an overview of the total adoption.

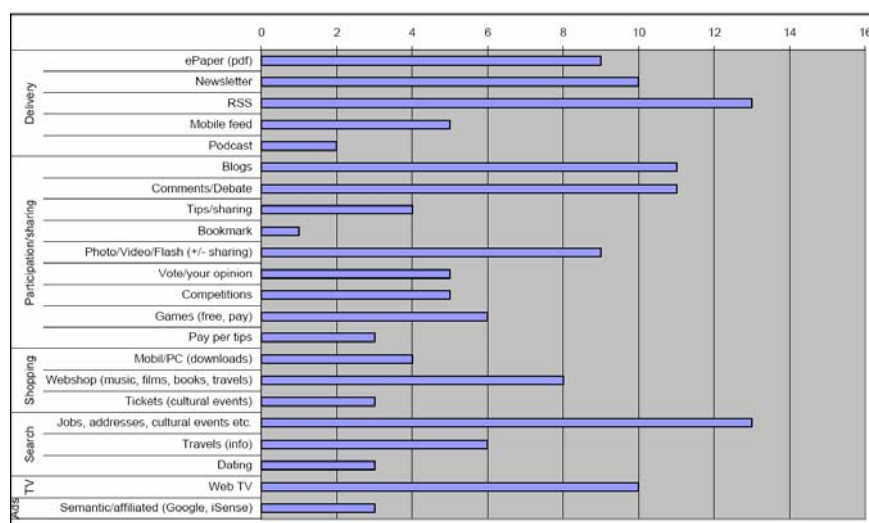

Figure 2: Overview of Web 2.0 features on Danish newspapers' websites, Feb. 2008.

Going into the details of this adoption reveals great differences in both quantity and quality of the utilization of the technologies and services. The sites affiliated with the two large media houses represents the bulk of the Web 2.0 adoption, but even though these two groups of sites have access to the same (respectively) technologies and services, they do not utilize them in the same manner. For example is the site of the free daily paper, 24timer, set up as a real *blogosphere*, the only one in the survey, while the sites of the morning paper, Politiken, and the tabloid, EB, focuses on publishing rather than participation; they offer blogging, but are not centred around it. This is also the general picture.

Table 2 lists a number of features that are either widely adopted or little adopted. As we include these features under the Web 2.0 umbrella, the listing of the little adopted features points at a variety of adoption that seem almost random, and it might also imply a vast space of unutilized possibilities for the traditional media industry.

General features – adopted by most	Special features – adopted by few
Partnering	Links to other news providers, e.g. international newspapers (Information)
External links	Free calendar for events posted by users (Information)
Diversification of content, sub-sites	Open Source (Information)
Hybrid media	Blogosphere/User universe (24timer)
Hyper local content	Gadgets/widgets (Børsen)
Archive search (mostly by subscription)	Webcam (Politiken)
Pay per article	Very user-friendly sharing (Berlingske)
Tip/tell your friend	Forums: Stock market, politics (business.dk)
Most read	MyPaper (JP2, Nyhedsavisen)
Related articles	OurPaper/Pro-AmJournalism (Nyhedsavisen)
Tags	Payload music, films (BT, Urban)
	Radio (Urban)
	No web 2.0 features (Weekendavisen)

Table 2: Web 2.0 related features with either wide or little adoption

Even though the data presented in the survey point at wide adoption of Web 2.0 features by the traditional Danish media sector, in comparison with the Web 2.0 adoption of the ‘new media companies’ such as Google, Facebook or the Danish site Arto.dk (an extremely popular social networking site for youngster) the websites of the traditional Danish media sector seem to be far from reaching their potential for Web 2.0 adoption. Our data suggests that the changes we see in traditional media are driven by the ‘new media companies’ and that traditional media adapts to, adopts and promotes these changes, but are not themselves drivers of change. Their Web 2.0 activity does not seem to fully embrace the new possibilities. The current adoption seems random and driven more by fashion and fascination than strategic implementation of business models.

This becomes clear when we try to derive business models from the adoption of Web 2.0 features, as there seems to be no genuine ‘Web 2.0 business models’ connected to the websites in the survey. Most features seem to be adopted on the basis of a single logic: Increase traffic by offering the consumer a somewhat customizable product in order to increase advertising revenues. Thus, it is not the “Web 2.0 feature” in-itself that generates revenue, and the question is, whether traditional news media industry will become capable of generating profit in the realm of Web 2.0, where companies like Google or Facebook are natives. For example are the advertising models of these companies far more sophisticated than those of traditional media, revenues are generated by facilitating access to social networks, sharing of personal information etc. – profit is very closely linked with the user’s “Web 2.0 activity”. This seems not to be the case in traditional media today.

These findings are in accordance with Krueger, who states in her conclusion [Krueger, 2006, p. 292] that “Online news is ... an excellent example of how the newspaper industry in the physical world is grappling with the changes which moving to cyberspace requires”. On the use of business models in the news media she finds [Krueger, 2006, p. 296]:

“Most descriptions of Internet business models were rather static ..., and failed to take into account the dynamics of increasingly complex market environments. My findings make clear that the Internet gives business models a new flexibility that did not previously exist.”

Krueger also checked whether existing definitions, frameworks, taxonomies and components in the area of Internet business model research were valid for Internet business models in the news and music sectors. She concludes, that they were, but that they “... just did not go far enough and weren’t flexible enough for a constantly changing new business environment.” Osterwalder makes a similar conclusion in his dissertation [Osterwalder, 2002].

The authors of *Wikinomics* [Tapscott and Williams, 2006] note that though the significance of ‘prosumers’ – a term originally coined by Allan Toffler in 1980 to describe how the gap between producers and consumers is blurring – is now widely recognized, prosumption is still not embraced by traditional business:

“... most still confuse prosumption with “customer centricity”, where companies decide what the basics are and customers get to modify certain elements.” [Tapscott and Williams 2006, p. 125]

From different perspectives Tapscott and Williams, Tim O’Reilly [O’Reilly, 2006] and James Surowiecki, author of the much cited “*The Wisdom of Crowds*”



[Surowiecki, 2005], all state that the entire world of business will be undergoing never precedented changes as a consequence of the rise of the wise, creative, collaborating and sharing crowd that is the powerful core of Web 2.0. Accordingly, these authors point at a need for radically new approaches – businesses need to embrace collaboration, user-generation, re-mixing, copying, hacking etc. When the consumer become producer and vice versa the neo-classical economic models crumble. For the traditional media industry the need to take action is especially urgent:

“In no other industry is the tension between the pre-existing power of producers and the increasing power of self-organized customer communities so pronounced.” [Tatscott and Williams, 2006, p. 137]

The survey of the current state of the “Web 2.0 activity” of traditional Danish media confirms these authors’ claims. If profitable “Web 2.0 business models” are to be developed by the traditional media sector, we believe it is necessary to disregard the traffic related advertising models as the primary source of revenue and start to concentrate innovative forces on the development of business models that incites collaboration, embraces genuine user-generation, targets and involves networks and maybe foremost: Are independent of the traditional publishing based business models of traditional media.

But are these business models fundamentally different from those of traditional media?

### 3 New business models?

After an analysis of a manifold of business and e-business models (e.g.: Applegate [Applegate, 2001], Timmers [Timmers, 2002], Cherian [Cherian, 2002], Afuah and Tucci [Afuah and Tucci, 2001], Weill and Vital [Weill and Vital, 2002], Amity and Zott [Amity and Zott, 2001], Rappa [Rappa, 2002]) Hedman and Kalling ask:

“...does the Internet, dot-com and the networked economy require new business models?” [Hedman and Kalling, 2002, p. 134]

And they answer: NO! Hedman and Kalling claim that even if the so-called old business model might be greatly affected by e-business models, nothing has changed except alterations of the causality between the components of the business model.

“Every firm, wherever they compete (the Internet or the real world), needs a market with customers and has to offer services and/products at a certain price at a certain cost. The offering has to be developed and produced through activities and an organization that use resources to convert production inputs into offers.” [Hedman and Kalling, 2002, p. 234]

This conclusion is in accordance with Porter [Porter, 2001], [Porter, 2008], who still claims that his strategic model from the seventies [Porter, 1979] can be used even in a world of rapid change and extreme complexity. Only minor alterations in the Five Forces and the Value Chain are needed, but the six basic principles behind his thinking are not threatened. Rationality and analysis in any industry is still the most needed approach. Porter writes:

“In our quest to see how the Internet is different, we have failed to see how the Internet is the same. While new means of conducting business has become available, the fundamentals of competition remain unchanged. The next stage of the Internet's

evolution will involve a shift in thinking from e-business to business, from e-strategy to strategy. Only by integrating the Internet into overall strategy will this powerful new technology become an equally powerful force for competitive advantage" [Porter 2001, p. 78].

Even without the "e" business models based on the strategic framework of Porter are based on neo-classical economic thinking. To develop genuine "Web 2.0 business models" there seems to be a need for new frameworks for business model development. According to Gordijn and Akkermans [Gordijn and Akkermans, 2003] classical e-business models focus on IT Architecture and/or Business Processes. This is in accordance with the findings of both Krueger [Krueger, 2006] and Osterwalder [Osterwalder, 2002]. However, Gordijn and Akkermans point to the fact that there is a need for a third perspective; the value perspective. So in their ontology – named the e<sup>3</sup>-value model - all three perspectives are represented:

- Business managers who decide whether or not to go ahead with forming the value constellation.
- Business architects who design business processes and responsibility structures.
- IT architects who design IT support for business processes.

Our findings based on the survey of the use of Web 2.0 features by traditional Danish news media are in accordance with these conclusions of Gordijn & Akkermans.

#### **4 Conclusion: A new business model ontology for the traditional media sector?**

As the ontology of the e<sup>3</sup>-value model points out, any e-business model should include the following qualities: (1) economic value that are created, exchanged, and consumed by all actors, including who is doing business with whom, (2) power elements, not only prices themselves, but the actors who select the service or product, (3) cover all important issues in order to create a viable and sustainable comprehensive, transparent model, (4) incorporate an encouraging way of visualising for better mutual understanding and communication, (5) focus on possibilities for dynamic innovation and strategy [Gordijn and Akkermans, 2001] and [Gordijn and Akkermans, 2003].

An essential feature of this value quality in e-business modelling is the concept of network. In the neo-classical economic thinking the "Porter-stakeholders" (competitors, buyers/customers, vendors) is taken to be very constant in the industry. But in a knowledge economy where these stakeholders dynamically and constantly change into each other - and at the same time and in the same space exchange knowledge - the value creation and exploitation processes are totally determined by the network constellation of the actors and their offerings. In the words of Castells: The business unit of the future is *the network*. Castells explains [Castells, 1996, p.170-1]:

“...co-operation and networking offer the only possibility to share costs, and risks, as well as to keep up with constantly renewed information. .... Under the conditions of fast technological change, networks, not firms, have become the actual operating unit. ... This enterprise has the specific form that goals and the change of goals, shape and endlessly reshape the structure of means.”

This kind of enterprise, the network, must be able to generate knowledge and process information efficiently in order to adapt to the variable geometry of the global economy. It must be flexible enough to change its means as rapidly as goals change, under the impact of cultural, technological, and institutional change. And it must constantly innovate both its products/services and its business model, as innovation becomes the key competitive weapon. These characteristics are indeed features of the new economic system, and business modeling must be able to handle this challenge by developing business models that reflects cooperative exchanges of value.

## References

- [Afuah and Tucci, 2001] Afuah, A., Tucci, C. L.: “Internet Business Models and Strategies: Text and Cases”, McGraw Hill, Boston (2001)
- [Amit and Zott, 2001] Amit, R., Zott, C.: “Value creation in e-business Strategic Management Journal”, 22, (2001) 493-520
- [Appelgate, 2001] Applegate, L.: “Emerging networked business models: lessons from the field”, HBS case No 9-801-172. Boston: Harvard Business School (2001)
- [Castells, 1996] Castells, M.: “The Rise of the Network Society”; Blackwell Publ. (1996)
- [Cherian, 2001] Cherian, E.: “Electronic Business: the business model makes the difference”, In: Proceedings of the Eight European Conference on Information Technology Evaluation”, Oxford: Oriel college, (2001) 171-174.
- [Gordijn and Akkermans, 2001] Gordijn, J., Akkermans, J.M.: “Designing and Evaluating E-Business Models”; Intelligent Systems, 16, 4, (2001) 11 – 17
- [Gordijn and Akkermans, 2003] Gordijn, J., Akkermans, J.M.: “Value based requirements engineering: Exploring innovative e-commerce ideas”; Requirements Engineering Journal, 8, 2 (2003) 114-134.
- [Hedman and Kalling, 2002] Hedman, J., Kalling, T.: “IT and Business Models”; Copenhagen Business School Press/Copenhagen (2002)
- [Krueger, 2006] Krueger, C. C.: “The Impact of the Internet on Business Model Evolution within the News and Music Sectors”; University of South Australia (2006)
- [O’Reilly, 2005] O’Reilly, T.: <http://www.oreillynet.com/pub/a/oreilly/tim/news/2005/09/30/what-is-web-20.html?page=1> (2005) (last visited Apr. 10, 2008)

- [O'Reilly, 2006 ] O'Reilly, T.: <http://radar.oreilly.com/archives/2006/12/web-20-compact-definition-tryi.html> (2006) (last visited Apr. 10, 2008)
- [Osterwalder, 2004] Osterwalder, A.: "The business model ontology"; Lausanne University (2004)
- [Porter, 1979] Porter, M.: "How Competitive Forces Shape Strategy"; Harvard Business Review, Mar/Apr (1979)
- [Porter, 2001] Porter, M.: "Strategy and the Internet"; Harvard Business Review, 79, 3 (2001)
- [Porter, 2008] Porter, M.: "The Five Competitive Forces that Shape Strategy"; Harvard Business Review, Nov/Dec (2008)
- [Rappa, 2008] Rappa, M.: "Business models on the Web, 2002", available online at: <http://digitalenterprise.org/models/models.html> (last visited June 19th 2008)
- [Surowiecki, 2005] Surowiecki, J.: "The Wisdom of the Crowds"; Anchor Books/New York (2005)
- [Tapscott and Williams, 2006] Tapscott, D., Williams, A. D.; "Wikinomics"; Portfolio/New York (2006)
- [Timmers, 2002] Timmers, P.: "Electronic Commerce - Strategies and Models for Business-to-Business Trading", Wiley, Chichester (2002)
- [Weill and Vitale, 2002] Weill, P., Vitale, M. R.: "Place to space: migrating to ebusiness models", Harvard Business School Press, Boston, Mass. (2002)

## **Developing an User-Centred Project Involving the Web 2.0 Community: a Case Study Based on Video Sharing Websites (<http://e-guitar.univ-reunion.fr/>)**

**Olivier Sébastien**

(IREMIA, University of Reunion, France  
olivier.sebastien@univ-reunion.fr)

**Noël Conruyt**

(IREMIA, University of Reunion, France  
noel.conruyt@univ-reunion.fr)

**Abstract:** The Web 2.0 philosophy has brought new ways of using the web as a content repository and a sharing platform. Non-computer skilled people can now publish their own text, images, videos and/or sounds and take part in communities created around topics they like.

It has also brought an opportunity to propose resources to a potentially huge audience. Indeed, a promotional video posted on YouTube can be watched by millions of users. That is why we wanted to know if it was possible to take advantage of this possibility to recruit testers for our music learning tool: our development is user centred, so it is important for us to have it evaluated by lots of testers. Until now, they were recruited in a geographically limited area, i.e Réunion Island.

Therefore, we have set up an experiment called “E-guitar Sonar Edition” to gather information about this recruiting opportunity. The idea is thus to design a free downloadable version of our system (originally, it was a DVD), put it on a dedicated web site and have it promoted thanks to video sequences posted on YouTube and Dailymotion, the two majors video Web 2.0 sharing sites, the most appropriate services.

This article presents the conditions and the process used. It also deals with the assessment part, the way we gather feedback and finally shows the firsts results. The experiment itself has no limit in time, so it is still currently running.

**Keywords:** Knowledge management, skill-oriented learning, User-centred assessment, Music learning, Web 2.0-based services

**Categories:** H.4.2, H.5.1, H.5.2, H.5.4, H.5.5

### **1 Introduction**

The Web 2.0 philosophy has brought new possibilities for user to behave as content producer instead of passive consumers [Tapscott, 06]. Activity is concentrated around big hubs like YouTube, MySpace, Facebook and many other resources sharing websites. This fact has an interesting consequence: targeting a large audience seems easier than before, at a lower cost. Indeed, it is more difficult to draw the attention of a visitor from a web search engine, whereas most Web 2.0 sites automatically propose related content to what the user is currently consulting. Therefore, he is at only one click of distance to a new resource. Moreover, it seems more attractive than a simple

link because a thumbnail is often provided, that gives an idea of what is behind the click.

Thus, we wanted to know if we could take an advantage of this opportunity to facilitate our work of building practical knowledge management tools, at a fairly low cost. Our team at the University of la Réunion has focused for some years on skills transmission with instrumental music as our field of experimentation. The development of product/service is iterative and user-centred that is why we need external feedback to improve our softwares.

Unfortunately, recruiting beta testers is not easy: most of them want an immediate substantial reward, without mentioning the geographical limits. However, users who want to involve themselves deeper in the project exist, we call them gold testers. The problem we encountered is that we have to access to a large community in order to find enough of them to validate the evaluation. That is why we had the idea to search and engage a relationship with this kind of profile thanks to popular Web 2.0 services. Finally, the question is: can YouTube help us to work? Of course, it would be interesting to target a more specialized audience such as music teaching sites, but as we are not aware of similar previous experiences, we wanted to address the largest community, despite not being focused on one particular topic, in order to acquire the reference level.

Thus, this paper aims at presenting the process we have created to answer the above-mentioned question and the first results we had. The experiment itself is still in progress: we have chosen not to limit it in time.

In a first part, we will present the methodology and the tool proposed for testing, then we will focus on the access scenario, the monitoring and feedback side and we will finish with the firsts trends.

## **2 Methodology**

The idea is to adapt our existing DVD tool to take into account Internet constraints (bandwidth and file format) and release it as a free download from a dedicated website hosted at our University. Promotion would rely on one or two major Web 2.0 services like YouTube. Finally, a simple feedback solution is provided to gather users opinion. Let us start with a short presentation of our research in order to explicit why this idea seems relevant to us.

### **2.1 Project presentation**

#### **2.1.1 Skills transmission**

Our team works in the field of skills transmission. We have focused on this particular topic because it proposes many challenges. On one hand, it deals with human learning behaviour for constructing knowledge [Ackermann, 04], and on the other hand, it deals with skills that are very difficult to lay down on paper.

Concerning Instrumental e-learning, the domain we have chosen, the best way to learn this art has been the private lesson with a teacher for ages. There are of course lots of alternative media that have been created to materialize this knowledge and facilitate its transmission. But none of them has the same efficiency as the in-situ

course.

Paper was the only medium for centuries. Then came audio recording and video. Computing capabilities brought another dimension: interactivity. This is the cement between these media and it can be used to add a meaning.

Thus, our proposition is to use natural media that do not require much interpretation from the learner to represent the professor's skills and therefore learn by imitating the gestures. This was done in the context of the E-guitare project [Sébastien, 05].

### **2.1.2 The E-guitare project**

It started in late 2003 and is led in collaboration with the Classical Music Academy (CMA), the regional authority in music teaching, which ensure the quality of pedagogical aspects. E-guitare's aim is to build natural guitar learning systems that are efficient and easy to use. A system is a learner-centred tool designed to mediate the process of learning efficiently a piece of music without the professor or between two lessons with him. To do so, we heavily rely on multimedia. The development process is based on a co-design platform that involves designers and users. This structure is based on iterations around refined versions of the system that are confronted with users.

Two systems are proposed. The first one is an interactive DVD product that manages the teacher to student communication. To achieve this, the professor is filmed performing a musical piece, from various pedagogical angles of viewing. A time-stretched slow-motion feature is implemented to let the learner better analyse the movements. Technical advices are contextually attached to the music to help him taking over the difficulties once they are encountered. The idea behind is to stream the right information at the right time. An animated score and tablature is also provided for those who can read it. Finally, the learner steps forward through the piece, as he would have done with a teacher in front of him, but at his own speed.

The second tool is an add-on around the above product called Figs/Gloss2u that is still in development. It handles the student to teacher communication. Questions and answers about a tune are exchanged in an audiovisual way by using webcams and Flash Media Server [Sébastien, 07]. They are automatically indexed to the part of the music they are referring to. What is interesting here is that every debate is saved so that newcomers can take advantage of what has already been discussed.

According to our user-centred philosophy, these systems have to be evaluated by testers. Recruiting them is not so easy, especially for the interactive DVD because it is necessary to ship a disk. That why we wanted to build a full virtual version of it which promotion is done using Web 2.0 video hosting services.

## **2.2 The Sonar Edition**

Building a relationship that is entirely based on virtual tools requires to build a specific process. We have named it E-guitar (without the French final 'e') Sonar Edition, to separate this experiment with what we have already done. Here are the parameters we have set. The Sonar word reflects the fact that we wanted to put some light on a particular domain that is unknown to us, i.e what response can be expected from delivering a fully operational virtual DVD downloadable freely from the web.

### **2.2.1 Adapting the DVD system**

Shifting from a physical disk to a virtual one is not very difficult. The ISO standard supports the making of a disk image that contains a whole structure in one file which can be downloaded. Users can access to the content either by writing the image to a blank media (using a DVD Writer) or directly, by mounting it with a virtual drive. This is supported natively with MacOSX and Linux but requires a software like Daemon Tools with Windows. The main problem comes from the file to download: it can be very large (half a Giga Byte for an 1 minute tune). That is why we have decided to limit the amount of media embedded (6 down to 3 angles of viewing), and picked pieces that were not too long. Another idea was to propose each of the 8 tunes separately instead of just having one compilation, like we did before.

The music was selected to cover a wide range of styles, thus ensuring that most people will find something they like: classical, folk, rock, reggae... Our four guitar teachers created specific arrangements designed to be attractive and accessible at the same time for a beginner. Due to resources constraints, the musical pieces were either adapted from the public domain directory or original compositions. This is an important parameter because picking famous titles would certainly provoke a higher interest from visitors. However, this choice seems relevant to us because it allows to do the experiment in conditions that are not the best. Thus, we keep in mind that we will acquire the minimal trends, i.e the boundaries ones.

The whole content of the disks is in English but optional subtitles in English (and French) are also available for those whom English is not the mother tongue.

### **2.2.2 Creating a dedicated site**

The E-guitar Sonar Edition website has been created to manage the download of the virtual DVD. It contains information about the teachers, the proposed pieces and how to use the ISO images. In the Frequently Asked Questions part, we present the project, our motivation and the necessity for us to gather feedback. Several links points to a page that shows how to leave users feeling toward the system (described later in this article).

### **2.2.3 Promoting the Sonar Edition in the Web 2.0 community**

There are many sites claiming to belong to the Web 2.0. However, people tend to gather around the biggest ones: YouTube, MySpace, Facebook, Flickr or del.icio.us. Given the fact that our system is heavily video-based, it was a natural choice to rely on video sharing services. YouTube, a belonging of Google, is the biggest one, and at the time we started the experiment, Dailymotion was the second. Thus, we decided to post trailers of each piece with appropriate tags and a video description of the project on these two services. A link to our website is inserted both in the sequence and in the text description.

## **3 Scenario of use and monitoring tools**

Communication means between the visitor and us have been inserted at every step of the typical use case we have expected. Moreover, data retrieving trackers are inserted along the path.



### 3.1 Typical scenario

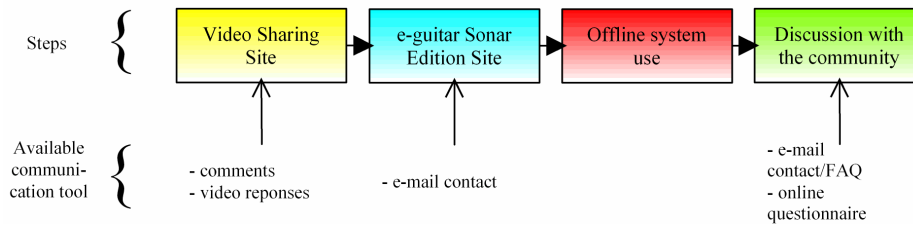

Illustration 3.1.1.: typical scenario

The global process is depicted on Illustration 3.1.1. It starts with the user discovering the project on YouTube or Dailymotion then clicking on the link to go to the Sonar site and downloading a virtual DVD. He can practice on his own and finally is supposed to leave a final feedback on his experience. As shown in the previous illustration, he can leave his opinion at any moment, so that we can detect if there is something preventing him from going to the next step. This is the qualitative part of the experiment.

### 3.2 Monitoring tools

The communication means evoked before are useful to obtain qualitative feedback. Monitoring tools allow to get quantitative information. Many of them are interesting because they are automatically obtained: figures are recorded without needing an explicit action from the user. They can be split into two categories: external and internal.

#### 3.2.1 External monitoring

It refers to the information gathered from servers that are outside our University network. Here are the parameters that can be observed:

- View count for each video post on YouTube and Dailymotion
- Number of subscribers for the channel
- Online questionnaire: testers are invited to fill in a 18 questions survey hosted on a service named my3q.com

#### 3.2.2 Internal monitoring

It is related to what happens from our server's side:

- The easiest source of information that comes in mind is the Apache web server log. Visitors leave traces for each requested file: virtual DVDs as well as web page elements. They are identified by their IP address. However, data retrieved is rather computer related than user related: operating system, web browser, software versions, etc
- That is why, it is completed by two free site tracking services: Xiti and Google Analytics. Each page and virtual DVD is tagged with an identifier so that they are able to record any activity. The results are presented in an online interface. It is possible to determine the geographical origin, the average time spent on the site, the number of pages viewed per visitor, etc

At this stage, we must precise that logs appear to be a debatable measure. Indeed, there are situations where they do not reflect the real activity, and this is particularly true when the overall number of entries in the file is low. The most important bias comes from the virtual DVDs count. Someone using a download manager will start multiple connections at the same time to speed up the transfer. Any automatic data analyzer like Webalizer will count multiple downloads whereas finally, only one person will have the file. It would be necessary to filter by IP address but this process can not be automated because most Internet users have it changed every 24 hours.

Finally, we solved that issue by inserting a tracker directly on the links that lead to the disk images, thus counting the number of clicks instead of the server requests.

## 4 First results

The E-guitar Sonar Edition has been released to the public on the 11<sup>th</sup> of February 2008. The promotion videos have been uploaded a few days before, from the 6<sup>th</sup> to this month. The problem concerning the downloads count was spotted during the first week, resulting on the subscription to the Google Analytics service (Xiti cannot handle this freely). At the time this article was written, we can present the results obtained from the launch of the edition to the 14<sup>th</sup> of April, which represents 64 days.

What is interesting here is to compare our audience on the video sharing websites with the number of visitors on the Sonar website and finally how many of them downloaded at least one piece.

### 4.1 Video sharing websites audience

The first thing we discovered is that YouTube audience is much larger than Dailymotion's one. After 64 days, the most viewed piece on the first one has 475 hit whereas on the second, it has only 73. It is about a six and a half ratio. The same thing occurs concerning the less viewed video (110 to 24). These audience figures are average compared to other similar videos posted approximatively at the same time: some are better than ours (especially if they feature a girl, even if she performs bad) whereas others are worst. Generally speaking, it is more difficult to attract people with beginner and/or not unknown pieces. As far as subscribing is concerned, results are bad: our *eguitarsonar* account only has 3 subscribers on YouTube and none on Dailymotion. Google's subsidiary gives a better exposition than its competitor. Consequently, we have decided to leave Dailymotion to concentrate on YouTube figures in the following analysis.

### 4.2 Activity generated on our side

#### 4.2.1 Quantitative results

They are synthesized on the Illustration 4.2.1. The average daily audience on YouTube, for all proposed video, is 31.52 views. It can be compared to the average value of 3.16 visits on our site per day and about 20% of them will make at least one download of a virtual DVD. This ratio is the transformation factor.

We must precise here that YouTube is not the only source: people also come directly, via our E-guitare main site (where an article has been posted) or other guitar

sites linking to us and from search engines. On the whole period, YouTube and Google in general represents half of the incoming traffic and it tends to increase. That was not the case at the beginning because shortly after the release, lots of access were done by our technical staff and relatives for demonstration purpose and to detect bugs (hence the initial peak). It is not the case anymore. This perturbation can not be filtered as visiting our site is anonymous. We decided that forcing people to create an account was a discouraging barrier. However, we managed to remove connections from our team inside the University, as they are easily identifiable in the logs (internal IP address pool).

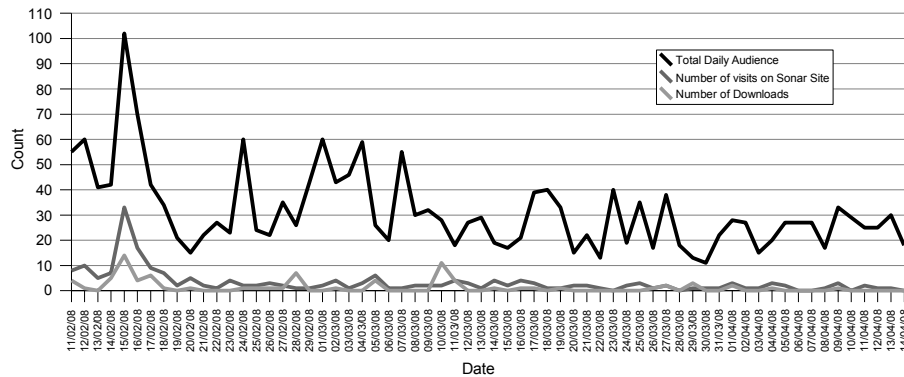

*Illustration 4.2.1: Daily Audience on YouTube compared to the number of visitors on Sonar website and to pieces download*

One can also notice on the chart that some days, the number of downloads is greater than the number of visits. It comes from two facts: firstly, one user can request multiple images during one visit and secondly, a visitor can initiate a transfer one day and continue other downloads the day after during the same session. Time is GMT+4 referenced. In absolute value, on the studied period, the activity represents a maximum traffic of 52.5 GB and 81 downloads of our system. This is particularly interesting because in the past it took us about six months with a physical DVD to have the same diffusion that we had in 64 days, at a lower cost. There is no doubt that from this point of view, the experiment is a success.

#### 4.2.2 Qualitative results

They mainly constitute the explicit communication from the visitors to us. The fact is that for the moment, there is no qualitative information at all! A comment was left for one piece but it was not related to our system. No email were sent and nobody answered the questionnaire. Three hypothesis can be formulated to explain this phenomenon, partially based on the experience we had on the main e-guitare project:

- People did not have enough time practising to send feedback
- The proposed feedback solutions do not fit. Concerning this, we decided not to create a blog because it relies on topics decided by the authors, not users and we didn't want our visitors to be constrained. The feedback tools selected are simple and people are used to them but maybe they are not attractive enough

- Most people do not care about giving feedback and we have not found any gold tester yet

For the moment, we have no information to confirm one of these possibilities. However, we are thinking about ways to improve the situation.

### 4.3 Improving figures

Basically, to have more chance to find out users that want to involve, we must increase the visibility of our work among the others. First idea that comes in mind is to subscribe to YouTube Promoted Videos program. It allows to appear in dedicated area of the video page, when visitors are watching a video about the same topic. The complementary service is the Google AdSense program that displays contextual ads on another section of the page.

There is another mean to slightly improve the audience: provide content regularly. Indeed, it allows to build a bigger video pool that is more likely to be well ranked in users search requests. But all these solutions need specific resources.

## 5 Conclusion and perspectives

One can find that the initial results are mixed: on one hand, exposition of our software is large compared to the investment, but on the other hand, figures are rather low and finally, no active user has been found out for the moment: most people seem to behave as consumers. However, from an experimental point of view, this step is very important because it allows us to draw what we call the reference level. Indeed, this is what is obtained with a very low amount of resources, without commercial aspects and when no specific communication process (advertisement) is provided.

There is no doubt that using Google business services like AdSense or YouTube Promoted Video, the amount of visitors would have been greater, but in what proportion? Thanks to this experiment, it will be possible for forthcoming development to evaluate very accurately the efficiency of the operation, by comparing it to the reference level we have determined.

## References

[Ackermann, 04] Ackermann, E., *Constructing Knowledge and Transforming the World*, in *A Learning Zone of One's Own*, 2004, 17-33

[Conruyt, 06] Conruyt, N., Conruyt, P., Sébastien, O., *A Methodology for Designing E-services from a Co-Design Platform*, *i-Know'2006*, Austria, 2006

[O'Reilly, 05] O'Reilly, T., *What Is Web 2.0: Design Patterns and Business Models for the Next Generation of Software*, 2005

[Sébastien, 05] Sébastien, O., Conruyt, N., Conruyt, P., *Natural Music E-learning System Development: the E-guitare User-centred Approach*, *ICOOL 2005*, South Africa, 2005

[Sébastien, 07] Sébastien, O., Conruyt, N., Calderoni, S., *Enhancing Music Learning Experience through a Dedicated Web 2.0 Oriented Service*, *i-Media'2007*, Austria, 2007

[Tapscott, 06] Tapscott, D., Williams, A., *Wikinomics*, Penguin Group, 2006.

## **Aggregation and Personalization of Infotainment – An Architecture Illustrated with a Collaborative Scenario**

**Stéphane Turlier, Benoit Huet**

(Institut TELECOM – EURECOM, Sophia-Antipolis, France  
{Stephane.Turlier; Benoit.Huet}@eurecom.fr)

**Thomas Helbig, Hans-Jörg Vögel**

(BMW Group Forschung und Technik, Munich, Germany  
{Thomas.Helbig; Hans-Joerg.Voegel}@bmw.de)

**Abstract:** A user-centric architecture of infotainment content adaptation to the context is presented. The architecture uses component technologies in term of business logic and functionalities offered by social web (OpenID, FOAF) and semantic descriptions of MPEG-7 and MPEG-21. Technological alternatives are discussed and adapted to the specificity of vehicle applications in terms of scalability and platform mobility. The requirements of the architecture are motivated by the presentation of a scenario.

**Key Words:** MPEG-7, MPEG-21, FOAF, OpenID, content-based Multimedia Retrieval, Hypermedia systems, Web-based services, XML, Semantic Web, Vehicle

**Category:** H.1.2, H.3.1, H.3.3, H.3.5, H.3.6, H.5.1, H.5.4

### **1 Introduction**

The increasing amount of metadata describing multimedia content makes possible the personalization of the multimedia experience. Different approaches of music recommender systems based on description metadata have been proposed mainly on music-centric approaches. However, to our knowledge, no architecture addresses the problem of delivering audio cross-media content in a user-centric approach. The goal of this article is to show how the combination of multimedia description and semantic user descriptions can lead in a proper architecture to propose a more user-centric approach of multimedia personalization and to explain how it can be used in a collaborative scenario.

### **2 An automotive scenario of collaborative filtering**

In order to identify the requirements of the architecture, we imagined this scenario: *Andreas, Barbara and Christopher are a group of friends who want to go together to some sea resort on the coast for the week-end. Andreas proposed to Barbara and Christopher to use his car for the journey. When driving, they would like to enjoy a personalized entertainment program matching their preferences.*

Step 1: *Each of them has at least one profile containing preferences and this profile is accessible online. In their preferences they specify the type of content they like to listen to. Andreas likes listening to classical music and jazz, world news and sport news whereas Barbara prefers rock music, daily national news and Christopher also likes rock music and wants to hear every hour the stock-exchange variations. Christopher hates classical music, while Andreas is not really keen on stock-exchange market.*

Step 2: *Andreas, Barbara and Christopher start driving. During their journey they have to cross various regions from urban environments to mountains and the availability and the quality of the wireless service is changing. The multimedia system adapts its selection of resources depending on their availability.*

Step 4: *Andreas, Barbara and Christopher start a discussion; in order to be able to understand one another properly they want the multimedia system to lower the volume and to avoid playing back spoken content.*

Step 3: *The road mates want to keep track of their infotainment experience as a group. They may want to bind their profiles and to mark their common interest in order to refine the personalization of their return journey together.*

### **3 Infotainment available metadata are heterogeneous**

In order to adapt infotainment to the user, a good knowledge of the content is necessary. A description standard like MPEG-7 provides an extensive framework even if it has still few commercial applications. However a wide range of multimedia content is now reachable from a vehicle but available metadata are unequal depending on the kind of source.

#### **3.1 Live broadcasted content (Push-Paradigm)**

##### **3.1.1 Analogue sources**

Historically, live content (push paradigm) available by analog radio was the first type of media content available in the cars. Today the excellent coverage by AM and FM radio of most of territories makes possible the delivery of infotainment very easily and everywhere. Even if originally now metadata was provided by traditional FM radios, RDS makes possible to identify them and to change dynamically frequency when moving, more over new techniques like RadioText Plus [RDSForum 2005] provides metadata like the title and the name of the artist currently being played.

##### **3.1.2 Digital sources**

The digital standards like DAB-H, DVB-SH or T-DMB widen the diversity of available live programs and enable the distribution of description metadata along

with them. However, as analog broadcasted sources, digital broadcasted sources do not provide any sort of personalization and are delivered on an inflexible timely fashion.

### **3.2 On-Demand available content (Pull-Paradigm)**

The pull paradigm enables the user to select exactly the content that he/she wants to listen and to listen to at any moment. Stored content on recordable media (CD, DVD), flash Medias or hard drives (MP3 players, cell-phones, etc) have the advantage to be available even when no wireless communication is reachable. The drawback is that the audio content available on them is limited to the storage capacity of these media which has consequences in term of diversity and it cannot be updated without synchronization. But above all, the new breakthroughs in terms of available data rates among wireless connections such as UMTS, Wifi or Wimax make more ubiquitous the online music catalogues (Amazon, iTunes, Rhapsody, etc) and audio podcasts. In our architecture, our client is able to access various online music libraries and also to update podcasts. Description metadata coming along with this type of content is the largest and the most accurate. Online music catalogue tag their music items with ID3 tags or equivalent in order to index them more easily. Podcasts are described using a standardized XML syntax. In case of dealing with untagged stored music like CDs, services like Gracenote or MusicBrainz, can overcome the lack of metadata with a fingerprint recognition technology.

## **4 Describing the driving context**

### **4.1 Available network resources in the vehicle**

In this scenario, we will assume that the capacities of the terminal are not changing and are independent from the vehicle (the same software is installed on the same hardware in all the vehicles using our platform delivery service). As a result our delivery platform will not take in consideration, any adaptation of the content to the nature of the client (transcoding, transmoding, etc) which would be beyond the scope of this publication. However, we still take into account the versatile nature of the wide-band connection, i.e. the client can automatically switch to an FM radio when no more online connection is available or when the rendering of a live-content is requested, and when no FM radio is properly available switch to AM radio or to a local content resource. MPEG-21 framework is well suited to describe the context.

### **4.2 Driving conditions**

Driving conditions refer to the environment from a user-centric point-of-view. MPEG-21 provides also descriptors for the geolocation, time, audio environment

Type of source	Personalization	Available Metadata Content	diversity/update	Coverage and availability
Analog Radio Broadcast	None.	Limited to RDS and RD+ standards for FM.	Large choice of radios. Up to date live news available.	Large.
Digital Radio Broadcast	None.	Description of the broadcasted programs.	Large choice of radios. Up to date live news available.	Limited areas depending on the technology used.
Stored Media	On demand, possibility to rate content.	ID3 tags (title, artist, genre)	Not up-to-date, diversity depending on the amount of stored data.	Independent of coverage.
Online Infotainment (On-Demand catalogues, Podcast services)	On demand, possibility to rate content and see other people ratings.	Very large. ID3 tags included in downloaded MP3s. XML description of podcasts using Atom or RSS.	Very large choice of content. Last album released available. Live streaming and up-to-date podcasts.	Wifi, Wimax, limited to urban regions. UMTS still unavailable in remote regions.

Table 1: Comparison of the different types of infotainment sources available and their possibilities in term of mobility and collaborative adaptation

and illumination characteristics. Unfortunately, it does not provide descriptors using traffic condition or weather driving conditions that are really influencing the driving experience. Nevertheless, based on geolocation and time description, the system can easily retrieve traffic and weather information from online services or infotraffic sources. This information can thus be stored using explicit semantic specification [Tsinaraki and Christodoulakis 2006].

## 5 Defining and creating user profiles for a personalized experience

The creation of user profiles can come from various sources. The easiest solution is a web portal where the user fills in some fields concerning his music tastes.



But there is very little chance that users may want to spend a lot of time in defining his music tastes. Moreover, his tastes may change in time and need being updated. In terms of music personalization, an incredible amount of internet services are now available online such as Imeem , Last.FM or Rhapsody . Not only do they allow creating easily a user profile, by selecting artists or music tracks as favorites, but some of them also update their user's profiles by monitoring user behaviors or saving relevance feedback. Actually, user profiles are not static data at all and need being updated. The description of an audio-user profile for a driving entertainment experience should contain the following information:

- Music preferences: The music preference should identify what the user likes to hear when driving. The simplest way is to record ratings of each song, the personalisation system can then choose the songs that the user likes at best. Same approach can be done by artist or by genre so as to broaden the amount of music items that are rated.
- Non-musical infotainment preferences: Non-musical infotainment refers to an editorially-defined program like a news edition from a commercial radio. The user may want to precise if he wants to hear the last edition of the news (i.e. exactly on time when it is being broadcasted, it could be the case for football match results for instance), if need be, the client has to switch to a push service paradigm, otherwise the client can download the latest podcast of the program and render it.

Preferences concerning musical as well as non musical infotainment are not only user dependent but rather user context dependant. As previously mentioned, we are dealing here with an audio-driving profile but the definition of an ontology describing the different context of driving is necessary to refine the adaptation policy. For instance, the user may have different preferences depending if he is driving by night or during the day. FOAF provides a basic way to describe preference using the interest descriptor [Oscar et al. 2005]. The interest of FOAF is that it can enable to bind different preference profiles from different users. A differentiation between the sort of knowledge between these users is semantically possible (colleagues, friends, etc). MPEG-7 Description Schemes provides a much more detailed way to describe the user preferences themselves via its `Filtering-AndSearchPreferences`, `Preference-Conditions`, `ClassificationPreferences`, `SourcePreferences` descriptors. The combination with various description schemes like (genres or artist) and MPEG-21 environment description enables very refined description of preferences depending on context.

## 6 A user-centric architecture for flexible context adaptation

In this section, we present an architecture which is able to handle the integration of preference profiles in terms of infotainment. Our architecture core functionali-

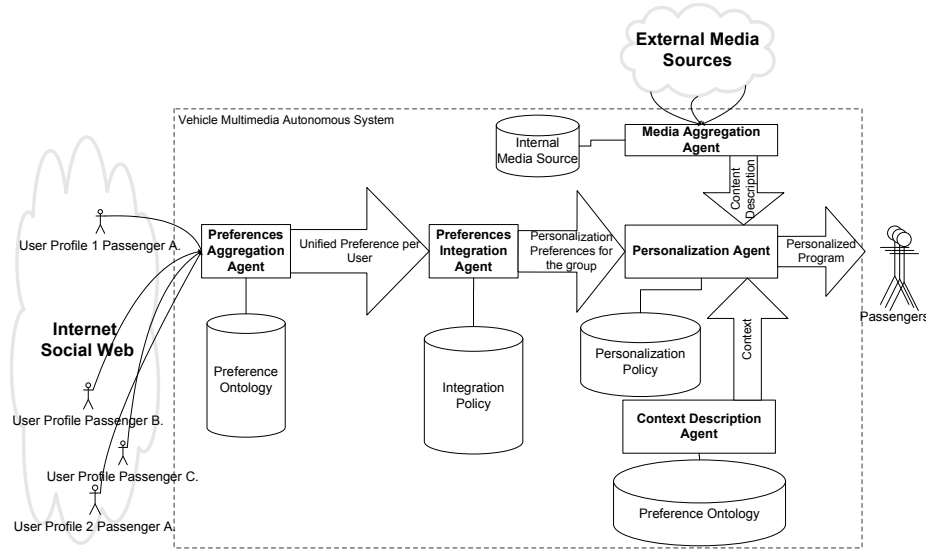

**Figure 1:** Architecture for multimedia preferences adaptation to the context

ties are the creation of personalization policies based on the user preferences and adaptation policies, and the delivery of a personalized service based on the previously created personalization policy and a knowledge of available content. The architecture makes use of the available metadata for the various infotainment sources from analog broadcast to on-demand online infotainment services.

A profile aggregator is a functional component that can retrieve personal profiles coming from various sources. A single user can have different profiles on different online services. Thus a mechanism to discover and resolve these different profiles is necessary if we want to aggregate them. OpenID, [Recordon and Reed 2006] is an example of a universal way to address and discover different services with a single identity. As previously said, those profiles can come from various sources and have to be integrated, meaning that the aggregator can understand the different standards used by the different services and process them with its own ontology before they are merged into a group profile.

A preference integrator is a functional component that combines them to create a common infotainment personalization profile. The preference integrator must have its own integration policy, for instance it may decide to give more importance to the preference of the driver of the vehicle. Several approaches for making decision that pleases everyone have been proposed, [O'Connor et al. 2001] and [Chao et al. 2005]. The role of the integration policy is to describe which approach has to be processed by the system. The context description agent is a

functional component that can describe the driving context. It combines the output of local sensors like the noise level and the luminosity, with content provided by GPS position or traffic information.

Contextual updates are regularly sent to the personalization agent which is a functional component that matches the personalization profile with the context description and available content to provide a personalized infotainment service. The personalization policy describes which approach has to be used to display adapted content. A basic approach could be to take the highest ratings and display content items corresponding to these ratings. However a limitation is that only the items which have been rated can be proposed. Recommendation models based on music similarity [Selfridge 1995] or latent semantic indexing [Hofmann 2004] make possible the creation of playlists which includes musical items which have not been rated but that the user may like. Another limitation of rating music by genre is that it is a very music-centric approach and thus is limited to the nature of the genre taxonomy used, [Pachet 2000]. A more user-centric approach has also been proposed to overcome this problem, [Lesaffre et al. 2003].

## 7 Illustration of the architecture with the scenario

Step 1: *Each of our three travel friends has a profile containing preferences and this profile is accessible online. In their preferences they specify the type of content they like to listen when driving.* In this step, online services are used to describe the user preferences. The user profile has to be available online in order to be retrieved by the content aggregator. The profile integrator compares these aggregated profiles and uses its integration policy to combine them. The integration policy chooses to give priority to the driver of the car (Andreas) and to render classical music even if Christopher hates it.

Step 2: *Andreas, Barbara and Christopher start driving. During their journey they have to cross various regions from urban environments to mountains and the availability and the quality of wireless service is changing.* When they start driving from their home city, the multimedia system can reach easily broadband wireless access. Podcast download and music libraries are used to propose to the user a content matching as much as possible their preferences. When they get away from the city and enter a mountainous environment, the personalization agent is informed by the context description agents of the loss of the online connection. The multimedia system switch seamlessly to local content available or to analogue radios if available.

Step 4: *When leaving each other, our three road mates want to keep track of their infotainment experience as a group. They may want to bind their profiles and to mark their common interest in order to refine the personalization of their future journeys together.* If available online FOAF files of the users are updated

to bind their profile. Thus, the profile aggregator can more easily locate and resolve their preferences in the future.

## 8 Conclusions

After identifying the different sources of metadata information necessary for a proper personalization of the content to a small group of users, we described an architecture that uses semantic descriptions of actors and resources to provide a personalized infotainment experience. Our architecture, involves both multimedia descriptions of the infotainment content assets and semantic description of the users. The combination of both information sources at different steps can be done using different strategies that have to be specified in the corresponding policies. Our scenario illustrates how our architecture can support both a service adaptation logic depending of the environment and a personalization logic adapted to the users.

## 9 Future Work

We will concentrate in the future on the different possible approaches that can be defined in the integration policies of user profiles. The problem of updating and refining the personalization system (based mainly on recommendation algorithms), by monitoring the users behaviour as a group will also be addressed.

## References

- [Chao et al. 2005] D. L. Chao, J. Balthrop, and S. Forrest. "Adaptive radio: achieving consensus using negative preferences". Proc. ACM SIGGROUP, 2005.
- [Hofmann 2004] T. Hofmann. "Latent semantic models for collaborative filtering". ACM Trans. Inf. Syst., 22(1):89-115, 2004.
- [Lesaffre et al. 2003] M. Lesaffre, M. Leman, K. Tanghe, B. De Baet, H. De Meyer, and J.-P. Martens. "User-dependent taxonomy of musical features as a conceptual framework for musical audio-mining technology". Proc. Stockholm Music Acoustics Conference, 2003.
- [O'Connor et al. 2001] M. O'Connor, D. Cosley, J. A. Konstan and J. Riedl. "PolyLens: a recommender system for groups of users"; Proc. ECSCW'01, Norwell, MA, USA, 2001.
- [Oscar et al. 2005] C. Oscar, R. Miquel, and P. Herrera. "Foafing the music: a music recommendation system based on rss feeds and user preferences". 2005.
- [Pachet 2000] F. Pachet. "A taxonomy of musical genres". In RIAO, April 2000.
- [RDSForum 2005] RDSForum. Radiotext plus (rtplus) specification, 2005.
- [Selfridge 1995] E. Selfridge-Field. "In melodic similarity - concepts, procedures, and applications". 1998.
- [Tsinaraki and Christodoulakis 2006] C. Tsinaraki and S. Christodoulakis. "A multimedia user preference model that supports semantics and its application to mpeg 7/21"; Multi-Media Modelling Conference Proceedings, pages 8 pp.-, 2006.

# ActiveTM

## The Factory for Domain-customised Portal Engines

**Lutz Maicher**

(Topic Maps Lab, University of Leipzig, Germany  
maicher@informatik.uni-leipzig.de)

**Benjamin Bock**

(Topic Maps Lab, University of Leipzig, Germany  
bock@informatik.uni-leipzig.de)

**Abstract:** Our goal is increasing the users' value and experience *and* decreasing the implementation time for web portals. To achieve this goal we adopt a subject-centric perspective on information architecture. The fundament of this approach is that portals should be driven by subject-centric models of the portals' domains. Out of these domain models, the interaction and interface design of the portals is self-evident. Amongst others, the international industry standard Topic Maps is a portal technology and an implementation of the subject-centric modelling paradigm. With ActiveTM we introduce a technology, which implements a Model-driven approach to automatically create domain-customised, subject-centric portal engines, based on Topic Maps. ActiveTM has proved as technique for reducing the implementation cost of portals enormously and the implied subject-centricness increases the users' value and experience significantly.

**Keywords:** subject-centric, Information Architecture, Ruby, Topic Maps, Ruby Topic Maps, RTM, ActiveTM, Semantic domain models, Web 2.0, portal federation, XML, XTM, Model-driven development

**Categories:** D.2, H.1, H.5

## 1 The Benefits of a Subject-centric Information Architecture

The Information Architecture Institute defines Information Architecture (IA) as “*the structural design of shared information environments*”.<sup>1</sup> Further, it is defined as “the art and science of organising and labelling web sites, intranets, online communities and software to support usability and findability.” The efforts of IA are focused on two goals: increasing the value of the users *and* decreasing the costs building and managing information systems.

Though years of discussing are passed by, today's portals or websites are often still driven by documents or fixed structures. Not the subjects of the content drive the users' experience and navigation, but strict hierarchies of sites reflecting organisation charts or arbitrary content categorisations. David Weinberger's discussion about the miscellaneousness of everything [We07] illustrates impressively the power which can be unleashed when disburden the information systems from these rigid structures.

---

<sup>1</sup> [http://iainstitute.org/en/about/our\\_mission.php](http://iainstitute.org/en/about/our_mission.php) (April 7, 2008)

In light of this potential we argue, that behind the scenes IA must change to a *subject-centric* information architecture. What does it mean? It is obvious, that a portal anyway represents a domain. Consequently, the portal must be driven by the *domain model*. Each domain consists of different subjects which are variously *intertwined* by differently typed relationships. Such subject-centric domain models must define the interaction and interface design. These portals, reflecting the domain as it is, will directly result in an increased experience, with added value for the users. This value increasing effect has already been proofed empirically [OP07].

Within this article we further show that the subject-centric approach allows decreasing the implementation time and costs for new websites or portals. In ActiveTM, the Ruby based technique presented here, the ontology of the domain models is directly used for the model driven production of a domain-customised portal engine.

Summarised, building websites or portals around the subject-centric domain models they represent, will increase the portals' user value and experience *and* simultaneously decrease the implementation time and costs for these information systems.

The remainder of this paper contributes the following. In chapter 2 we sketch an existing reference model for information architecture, which reveals the central position of the domain models in the development process of the sites. In the following chapter 3 we introduce the subject-centric approach for domain modelling and present Topic Maps as one implementation of this approach in short detail. In this context, the term *subject-centric information architecture* is defined. In chapter 4 the relationship between the subject-centric domain models and the resulting subject-centric interaction and interface design of the driven websites is shown by the example of the implemented TMportal *Musica migrans*. Chapter 5 consolidates the discussion in ActiveTM, the Ruby based factory for subject-centric, domain-customised portal engines. In the concluding chapter 6 it is fast forwarded to the time when TMportals will start gossiping by using the built-in information exchange and integration facilities of the underlying portal engines.

## 2 The Elements of User Experience

As already discussed above, IA is defined as the “the structural design of shared information environments“. Under the title “Elements of user experience” Garrett [Ga02] introduced a reference model for the process of implementing information environments. The whole process consists of five panes, starting from the definition of the strategy and ending up with the surface design. Remarkably, the whole process is always viewed from two perspectives: on the one hand the produced portal is considered as hypertext system, on the other hand as software interface.

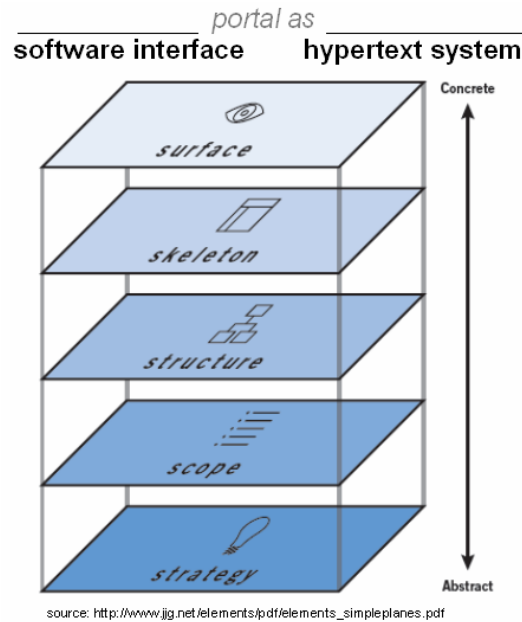

Figure 1: Elements of User Experience according to Garrett [Ga02]

Figure 1 summarises the reference model, more details are given in [Ga02]. Here we want to discuss the importance of the *structure* pane. This pane defines the domain model. It is the linchpin of the whole reference model. Most agreements in the strategy and scope pane will be condensed in the domain model, and the interaction and interface design developed in the skeleton and surface panes completely depend on the domain model defined in the structure pane. By exposing the importance of the structure pane, Garrett’s reference model is very well suited as basis for a subject-centric information architecture.

But the weak point in Garrett’s approach is the *laissez-faire* concerning the modelling technique to apply for creating the domain models in the structure pane. In the next chapter we introduce the subject-centric modelling paradigm as proposed fundament for the structure pane.

### 3 The Subject-centric Modelling Paradigm and Topic Maps

Each domain consists of a set of subjects. A subject is “*anything whatsoever, regardless of whether it exists or has any other specific characteristics, about which anything whatsoever may be asserted by any means whatsoever*” [TMDM]. Summarised, a subject is anything that can be a topic of conversation. According to the subject-centric modelling paradigm, for each relevant subject exactly one proxy is created within the domain model. All information about a certain subject is always appended to the according proxy. In most cases these information are relationships to other subjects. Within the domain models, these relationships are represented as

associations between the according proxies. As a result, each proxy becomes the unique information access point for all information about its subject. And the domain models will become highly interlinked.

ISO 13250, the international industry standard Topic Maps (TM) is an implementation of the subject-centric modelling approach. A topic map is a subject-centric domain model, consisting of *topics*, as subject proxies, and *associations* between them. Each topic can represent a set of typed names for the subject. Furthermore, occurrences allow representing typed properties of the subject. The associations between the topics are typed, role-based and n-ary. Summarised, TM provides a subject-centric modelling approach *and* a full set of basic modelling constructs, which is called a *legend* [DN07], like names, occurrence and full-featured associations for convenient domain modelling. For a deeper introduction into TM we refer to [AM05, Ma07]. Further we recommend a methodology for domain modelling in TM proposed by Garshol [Ga07].

Besides the expressive and flexible modelling constructs, TM provides a powerful *integration model* [Ma07b, TMDM]. This integration model assures that two topics representing the same subject will always be merged. Hence it is guaranteed that in a topic map there is always only one information hub for each subject. This powerful integration model is the fundament for the usage of TM as integration technology.

In the following chapter we demonstrate how the interaction and interface design of subject-centric TMportals are directly driven by the underlying subject-centric domain model, a topic map.

#### 4 TMportals – how the Subject-centric Domain Model drives the Interaction and Interface Design

The interaction and interface design of a subject-centric information environment are directly driven by the *ontology* of the underlying domain model. A domain ontology defines the main subject types and the main relationships in the domain [Ga07].

A subject-centric portal mainly consists of two types of pages: index pages for each type in the domain ontology and individual pages for each subject in the domain model [Tr08].

*Musica migrans*<sup>2</sup> [Ma08] is a TMportal<sup>3</sup> designed and implemented by the Topic Maps Lab<sup>4</sup> at University of Leipzig.

---

<sup>2</sup> <http://www.musicamigrans.de> (April 7, 2008)

<sup>3</sup> <http://www.fuzzy.com/tag/?id=2238> (April 7, 2008) for links to further TMportals

<sup>4</sup> <http://www.topicmapslab.de/>



MUSICA MIGRANS  
Life courses of central and east European musicians

German Help News Imprint

search Login

A B C D E F G H I J K L M N O P Q R S T U V W X Y Z

{ Persons  
Places  
Nationalities  
Confessions  
Professions  
Sources  
Dates  
}

Aich Anton \* 1878 - 1963 \*  
Bargiel Waldemar \* 03.10.1828 - 23.02.1897 \*  
Becker Robert \* 1845 - 1919 \*  
Biernacki Nikodem \* 1826 - 06.05.1892 \*  
Bigdasch-Bigdashev Polikarp \* 22.11.1877 - 1946 \*  
Bilse Benjamin \* 17.08.1816 - 13.07.1902 \*  
Birnbaum Zdzisław Aleksander \* 28.02.1878 - 09.1921 \*  
Blima Franz-Ksaver \* 1770 - 1822 \*  
Bohdanov Yuchim \* 1860 - 1911 \*  
Bronsart[Mädchenamen Starck] Ingeborg (Lena) von \* 1840 - 1913 \*

Persons

Figure 2: Index page for the type “person” in the TMportal *Musica migrants*

The domain of this TMportal consists of the life courses of Eastern European musicians in the 19<sup>th</sup> century. The figure above depicts the *index page* for “person”, the main type in the domain ontology. Each entry in the index provides a link to the subject page of the according person.

MUSICA MIGRANS  
Life courses of central and east European musicians

German Help News Imprint

search Login

Training place

Persons  
Places  
Nationalities  
Confessions  
Professions  
Sources  
Dates

General  
Place of birth  
Place of death  
Training place  
Place of work  
Stage of journey

1869 - 1872		
Name of artist:	Klenck Robert	
Institution:	no entry available	
Educational goals:	Violonist	
	Komponist	
unknown - unknown		
Name of artist:	Lubicz Zdislav Anton	
Institution:	Leipziger Konservatorium	
Educational goals:	Pianist	
	Komponist	
unknown - unknown		
Name of artist:	Biernacki Nikodem	
Institution:	no entry available	
Educational goals:	Klavier	
	Komposition	
	Violine	
1846 - 1850		

Leipzig

Figure 3: Subject page for “Leipzig” in the TMportal *Musica migrants*

The figure 3 above depicts the *subject page* for Leipzig. In the portal this page is the central information access hub for this subject, with all its facets. In the domain model, Leipzig acts as a place for birth and death of musicians, but also as place for their educational and working periods as well as for the concerts they gave. All this information is represented in the subject page rendered out of the Leipzig topic in the domain model. In the underlying topic map all relationships of Leipzig to other topics are represented as typed associations, in the front-end they come up as links to the according subject pages in the portal. Out of the networked domain model a strongly interlinked portal is automatically produced.

After walking away from understanding the basic idea of subject-centric domain models to concrete portals driven by them, we want to define the term subject-centric information architecture *as the structural design of shared information environments with subject-centric interaction and interface designs, based on subject-centric domain models.*

Subject-centric information architecture is an approach to increase the users' value and experience of information environments. But only if supporting software exists, this approach has the full potential to revolutionise portal creation. In the next chapter we introduce ActiveTM, which provides the required technology.

## 5 ActiveTM – the Model-driven TMportal Engine Factory

A TMportal like *Musica migrans* is based on a Topic Maps engine. In general, a TMengine provides access to the standardised data model using a comprehensive Application Programming Interface (API) allowing programmers to create and modify topic map structures while transparently maintaining semantic consistency through the standardised integration model. The information is kept in memory or persistent storages [Ma07a, ch. B.8]. An advanced TMengine may have specialised facilities for convenient web application development [Bo08b, ch. 5].

Ruby is an interpreted, object-oriented programming language, which has gained remarkably popularity in the web application community within the last years. With Ruby Topic Maps (RTM)<sup>5</sup>, we developed a TMengine in and for the Ruby programming language, to fuse the subject-centric approach with appropriate web technologies. For more details about RTM we refer to [Bo08a].

RTM is an implementation of the ISO-standardised Topic Maps data model [TMDM] and features an in-memory as well as a persistent database back-end. It relies on the object-relational mapper ActiveRecord which is part of Ruby on Rails<sup>6</sup>. The persistent back-end supports all databases supported by ActiveRecord.<sup>7</sup>

RTM is developed using Model-Driven Development (MDD) techniques at two layers of abstraction. The standardised Topic Maps data model is implemented in a custom Domain-Specific Language (DSL) which describes all TMDM items, like topics, occurrences, or associations, including their properties, equality rules, constraints, and the rules for merging. It also includes the core relationships defined

<sup>5</sup> <http://rtm.rubyforge.org/> (April 7, 2008)

<sup>6</sup> <http://rubyonrails.com/> (April 7, 2008)

<sup>7</sup> Databases currently fully supported: MySQL, PostgreSQL, SQLite, SQL Server, Sybase, and Oracle.

by the TMDM, namely type-instance and supertype-subtype. At this layer of abstraction, RTM provides a non-conventional, but convenient way to create generic TMEngines, in any required programming language, as well as for Ruby. The main bottleneck of such generic TMEngines is that the provided APIs stick strictly with the terms used in the TMDM (the legend), *but they do not provide convenient programming interfaces for a certain domain.*

In this context, ActiveTM provides an innovative solution. The domain ontology, which for example should drive a certain portal, can be specified by using a custom DSL. Automatically, the source code of a full-fledged TMportal engine is produced, which is *customised* to this domain ontology. If, for example, the ontology specifies, that there are persons which might have relationships to their place of birth, the customised TMportal engine does not only have generic TMEngine interfaces to create topic and association objects, likewise classes for representing persons are available. These domain specific classes provide convenient getter and setter methods for handling the relationship to the birth place, which may be a simple characteristic as well as a fully specialised domain object.

ActiveTM provides many predefined facilities to define and generate all common characteristics and relationships of domain objects. The domain model classes and their methods are generated completely automatically. Using these classes and methods, the web application developers have a convenient interface directly to the domain model.

Additionally, creating highly customised characteristics and relationships is easy. This extra functionality is available both for generation of domain classes and within single generated classes. Including domain constraints inside the definition of characteristics and relations aids the validation of user-input at a central place.

This Model-driven approach for producing domain-customised portal engines has proved as technique for reducing the implementation time of subject-centric portals enormously.

## 6 Fast forward

We have argued that a subject-centric information architecture, where the developed portals are driven by the subject-centric models of the domain they represent, will increase the users' value and usability. Furthermore we have introduced ActiveTM as technique for creating domain-customised portal engines, which allow reducing the implementation time of the systems enormously.

The dissemination of subject-centric information architecture and the availability of scalable and productive software technology might lead to an advent of TMportals.

Looking fast forward, the emergence of crowds of TMportals will yield a new level of information exchange in the web. This is due to the twofold interfaces of each TMportal: besides human-centric representation of all information about a certain subject in an individual subject page, the same information can always be requested as Topic Maps fragment. This TMfragment is an XML-document (using a standardised syntax) which combines all information about a certain subject in a computer-readable representation.

The built-in integration model of TM allows that any TMfragment can automatically be merged into the current back end. The integration model which must

be implemented by a full-fledged TMengine assures that after merging there is always only one topic which grasps all information about a certain subject. It is obvious, that when federating distributed portals the back-ends and the front-ends can be updated automatically by using an appropriate subject-centric portal technology. The door for new content-oriented business models is wide open.

## References

- [AM05] Ahmed, K.; Moore, G.: *An introduction to Topic Maps*. In: The Architecture Journal 5, 2005.
- [Bo08a] Bock, B.: *Ruby Topic Maps*. In: Maicher, L.; Garshol, L. M.: *Scaling Topic Maps*. LNAI 4999, Springer, Berlin (2008).
- [Bo08b] Bock, B.: *Topic-Maps-Middleware. Modellgetriebene Entwicklung kombinierbarer domänenspezifischer Topic-Maps-Komponenten*. Diploma thesis at University of Leipzig (2008).
- [DN07] Durusau, P.; Newcomb, S.: *The Essentials of the Topic Maps Reference Model (TMRM)*. In: Maicher, L.; Sigel, A.; Garshol, L. M.: *Leveraging the Semantics of Topic Maps*. LNAI 4438, Springer, Berlin (2007).
- [Ga02] Garrett, J. J.: *The Elements of User Experience*. New Riders (2002).
- [Ga07] Garshol, L. M.: *Towards a Methodology for Developing Topic Maps Ontologies*. In: Maicher, L.; Sigel, A.; Garshol, L. M.: *Leveraging the Semantics of Topic Maps*. LNAI 4438, Springer, Berlin (2007).
- [Ma07a] Maicher, L.: *Autonome Topic Maps. Zur dezentralen Erstellung von implizit und explizit vernetzten Topic Maps in semantisch heterogenen Umgebungen*. Doctoral thesis at University of Leipzig (2007).
- [Ma07b] Maicher, L.: *The Impact of Semantic Handshakes*. In: Maicher, L.; Sigel, A.; Garshol, L. M.: *Leveraging the Semantics of Topic Maps*. LNAI 4438, Springer, Berlin (2007).
- [Ma08] Maicher, L.: *Musica migrans - Mapping the Movement of Migrant Musicians*. Presentation held at the Topic Maps User Conference 2008, Oslo. Slides available at (April 10, 2008): <http://www.topicmaps.com/tm2008/maicher.pdf>
- [OP07] Oh, S. G.; Park, O.: *Design and Users' Evaluation of a Topic Maps-Based Korean Folk Music Retrieval System*. In: Maicher, L.; Sigel, A.; Garshol, L. M.: *Leveraging the Semantics of Topic Maps*. LNAI 4438, Springer, Berlin (2007).
- [TMDM] ISO/IEC IS 13250-2:2006: *Information Technology - Document Description and Processing Languages - Topic Maps - Data Model*. International Organization for Standardization, Geneva, Switzerland. <http://www.isotopicmaps.org/sam/sam-model/>
- [Tr08] Trainor, K.: *An Information Architecture for Frank Lloyd Wright*. Presentation held at Topic Maps User Conference 2008, Oslo. Slides available at (April 10, 2008): <http://www.topicmaps.com/tm2008/trainor.pdf>
- [We07] Weinberger, D.: *Everything is Miscellaneous*. Times Book, New York (2007).

## Non-linear Story-telling in a Mobile World

Ralf Klamma, Yiwei Cao, Anna Glukhova,  
Andreas Hahne, and Dominik Renzel  
(Informatik 5 (Information Systems), RWTH Aachen University  
Ahornstr. 55, 52056 Aachen, Gemany  
{klamma|cao|glukhova|hahne|renzel}@dbis.rwth-aachen.de)

**Abstract:** Story-telling has been a means of bequeathing knowledge since aeons. Whereas the idea of the story-telling remains unaltered, the world around undertakes continuous changes. New media, new technologies and devices, new ways of communication define a new format of the story-telling. This paper proposes a new non-linear version of mobile story-telling in the emerging ubiquity of knowledge sharing. To support our concept we provide a description of multimedia services based on the MPEG-7 metadata standard used for our non-linear mobile story-telling environment.

**Key Words:** Multimedia, MPEG-7, Tagging, Story-telling, Mobile Services

**Category:** H.3.3, H.3.4, H.3.5, H.5.1, H.5.2, H.5.4

### 1 Introduction

Information sharing via story-telling is an ancient concept. Over centuries of development and evolution the story-telling method has not lost its power in a changing world. As one would expect, how stories are produced (media used) and consumed have changed. But the underlying intention to stimulate knowledge sharing and learning – the basic idea of story-telling – has remained unaltered. In today’s computer technology era, also the story-telling approach gets its new digital face. Joe Lambert writes in [Lambert 07]: “The digital context makes testing a particular music in the video much easier than in film and analog media, and so experimentation is encouraged. You may find that, by going against the expected, you create another layer of meaning that adds depth and complexity to your story”. Further on he stresses: “Digital storytelling is an opportunity to repurpose existing material to tell a story.”.

So, story-telling can be seen as an approach to developing learning histories [Roth and Kleiner 99] by creating knowledge hyper stories [Royrvik and Bygdas 02]. Another more important application represents knowledge sharing and learning in communities of practice [Wenger 98]. Moreover, digital story-telling intertwines semantic knowledge and episodic knowledge. For example, already reified concepts of communities stored as documents are linked with the narrative experiences gained from episodic knowledge. This combination of semantic and episodic knowledge serves for saving of situational context.

A story can represent either linear or non-linear sequence of actions. In a linear story, the plot is completely specified during story creation. Thus, the author

prescribes a linear path, while the user will have to follow in order to consume the story. Consequently, each part of the content is meant to be seen or heard in the same order every time. The only main.pdfinteractivity allowed to “jump” back or forward on the navigation path. Obviously, for the modern application of story-telling linearity is restrictive. The use of digital media for story-telling makes stories more effective (combination of various media types) and interactive (management by different users). Such stories strive for the creation of many branches.

We re-visit our approach and adapt it to current trends in mobile computing. Mobile phones, PDA, guidance systems, interactive white boards, etc. make the new way of human-computer interaction possible. Mobile story-telling offers flexibility and mobility for media interaction. This requirement on story-telling has been already recognized by projects like VIEW [Kuner 08] or InStory [CITI 08] providing story-telling on mobile devices for different media types. However, the stories in those systems are linear only. In the related work, another trend in story-telling is to combine stories with video games. For instance, Mateas and Stern chose dramas as the original stories to create video games in a narrative way [Mateas and Stern 05]. It is a successful attempt in applying the concept of soap-opera onto video games. Virtual story-telling is another project developed at the Institute ZGDV in Germany to combine story-telling and virtual reality technologies [Iurgel 05]. Story-telling can be also applied in software engineering. In the project CONTICI ([www.contici.org](http://www.contici.org)) the story-telling concept is used to trace the evolution of requirements presenting not only a communication medium for project community, but also a perfect learning resource.

In this paper, we show the importance of non-linear story-telling in the mobile world. We are relying on the formal definition of the MOD approached specified in [Spaniol et al. 06a]. The rest of the paper is organized as follows. In Section 2 we will present an application scenario of mobile story-telling to demonstrate the needs of non-linearity on the way to ubiquity. In Section 3 we discuss how the proposed concept can be realized, with regard to the technical specification of the existing services. The paper closes with conclusions and an outlook on further research.

## 2 Scenarios and Concepts of Mobile Story-telling

Imagine that you are visiting an unacquainted place destination. As a tourist, you have possibly prepared for the trip by getting a tourist guide in order not to miss anything. However, those guides do not offer any flexibility and merely provide limited information. One can try to overcome this restriction by printing out some information found in the web. How reliable is the information from a great variety of opinions given by users? Obviously, the best-fit advice might come

from your friends, colleagues, generally speaking, your communities. However, we can never be prepared for everything in advance. It is even not practical to taking a heap of papers with you in trips.

An appropriate solution could be some prevalent electronic small devices which can work like flexible tour guides, e.g. smartphones, PDAs, or iPhones. For example, some electronic guides like iGuide already exist [iTour 08] being capable of providing information of certain sightseeing places in cities or of artifacts in museums. However, they are similar to paper guides and provide different predefined routes. In case of getting unexpected free time in a foreign city, tourists might be in an even worse situation due to the lack of time for preparation. Very recently, the news about that Nokia has acquired Plazes (<http://plazes.com>) as well as the new release of iPhone stress the combination of location and communities.

We propose the concept of mobile story-telling. In the information retrieval aspect, tourists get a mobile access to the information about the routes that others have already taken, the places they have visited, the pictures they have captured. Barely nobody denies the usefulness of the stories from other travelers in the same communities, because interest and hobbies might be similar. Considering the problem that there are much fewer people who create information than those who use it, we have solutions in the information creation and information annotation aspects. We found that one of the reasons of such a phenomenon is the complexity restricts the recreation process of people's experiences. Usually, people get the possibility to upload trip pictures, to describe them, and to express their opinion, etc. only after coming back home from trips. Unfortunately, the impressions pale, the information gets forgotten. Consequently, the wish to share decreases, while the time span increases. Thus, mobile story-telling on mobile services provides ways to mobile media annotation and story establishment. In the information repurposing aspect, a non-linear story with different branches can be created based on input, if there is more than one member in your community who previously visited the same city and created a story about his/her trip. In the information monitoring aspect, GPS coordinates of the required services (e.g. picture capture, semantic annotation, information retrieval, etc.) during the trip can be monitored and used for story-telling. If two service requests were close to each other in terms of position, they were attached to one node of the story tree.

Moreover, using GPS tourists can start their virtual tour of the real life tour at any node of the already existing story which lies next to the current coordinates of the user. The detailed specification of the non-linear story creation is as follows. Adjacent media nodes  $action_i$  and  $action_{i+1}$  on a path are monotone regarding coordinates, i.e.,  $action_i(x, y, z) < action_{i+1}(x, y, z)$ . This restriction makes the tour reasonable and time independent. As the parts of different stories

are attached to one node, again the location is explored. However, the context of a tour has to be considered. If the route was created for pedestrians, the distance of 5 kilometers will take an hour of walking and only 10 minutes by car. Thus we have to define a restriction  $action_i(x, y, z) - action_{i+1}(x, y, z) \leq v_{max} \cdot (time(action_i(x, y, z)) - time(action_{i+1}(x, y, z)))$ , where  $p$  is the geographical position and  $v_{max}$  the estimated maximum moving speed in the tour.

### 3 MPEG-7 Based Media & Story Management

In order to realize the proposed tourist guide using the mobile non-linear storytelling concept, those web services which were developed in our previous research can be further used. They are also used in some other platforms such as NMV and MIST.

The Nillenposse Media Viewer (NMV) provides a wide range of image editing and annotation functions (cf. Figure ??, right). Users can tag, upload and search any type of media e.g. images and videos. Besides plain key word tagging and free text annotation, semantic tagging is also applied in NMV containing explicit definitions for the meaning of a tag. Each semantic tag represents one of the *Semantic Base Types* Agent, Object, Place, Time, Event, Concept, or State defined by the MPEG-7 standard.

NMV provides image tagging methods, i.e. using images to describe other multimedia including images, videos, etc. Moreover it allows the search for plain keywords by Boolean expressions as well as a search on the semantic tags of a medium. For instance, one can search for media whose keywords match the expression ‘Buddha’ or ‘Bamiyan’ and not ‘Religion’. Therefore, NMV enables the creation and management of the semantical knowledge of the story.

The NMV platform runs on the client side, representing the front end of the LAS environment [Spaniol et al. 06b] providing both user and security management. Users can receive permissions or prohibitions for certain services or methods and be merged to groups with common rights. Moreover, each object managed by the services can have specific access rights defined in so-called Access Control Lists. Since uploading, tagging and searching are implemented in LAS services, it is possible to check whether users are permitted to perform these operations. In particular, one group can also tag the same media with different annotations from another one, depending on their needs and habits. NMV presents a good service for media management, which is also implemented on mobile devices like Nokia N95 [Klamma et al. 07].

With regard to the data storage, images are stored on a FTP server. Videos are uploaded to a streaming server in the way that download and replay can be conducted synchronously. The metadata of the media is stored in a condensed version of the MPEG-7 XML scheme [ISO 02, ISO 03] in an XML database.



For the creation of non-linear stories we use the Movement Integrated Story Telling (MIST) service, which was intended to realize the combination of the objective *semantical knowledge* and the emotion-oriented *episodic knowledge* (cf. Figure ?? left). The process of story creation is split into a general part in which the plot is created and a detailed part in which the actual media is integrated. The available media base is the same as the one used by NMV, i.e., the semantic tags integrating the semantical knowledge into the story can be used, whereas the raw media represents the episodic knowledge. The paradigm of Movement Oriented Design (MOD) is the key structure of the stories created in MIST [Sharda 05]. Its basic idea is that each story consists of begin (describing a problem), middle (explaining the problem), and end part (solving the problem). Each of these parts can be decomposed recursively into *Central Story Units*. The result tree has the actual media as the tree leaves. Due to some restrictions of the Begin-Middle-End completeness, authors can define a successor relation among media which has to comply with the following general rules which ensure a reasonable story flow. (a) Each media instance is reachable (except the start media of course). (b) All successor relations are valid in the sense that begins are (optionally) followed by middles and middles are followed by ends of the same story unit. (c) Each story unit contains at least one begin, one middle and one end media instance.

Considering the graph in Figure 1, we recognize a story with two story units 0 and 4 and six media instances associated with begins, middles and ends (B, M, E). The arrows represent (valid) successor relations according to the MOD paradigm. One could not insert a successor relation between  $m_{MB}$  and  $m_E$  because of an incomplete Story Unit. Edges between  $m_{ME}$  and  $m_M$  (both are middle part media) and  $m_{MM}$  to  $m_E$  (middle and end part medium do not belong to the same story unit) are not allowed, either.

Because of both aspects, the story creation and its consumption, are implemented in the same application. Two main panels are realized, denoted as *Editor* and *Player*. The editor provides three windows: the story plot with its problem hierarchy, the detailed story editor for actual story creation and a panel which lists all employed media and the related tags.

The media player on the other hand shows a list of all possible successors for the last visited media instance and a tree of all problems treated by this media instance, whereas in the main panel the medium itself is displayed as in NMV.

Currently, stories – or linear subsets – can be exported into two file formats. One path can be selected and exported to the SMIL format [W3C 08]. This can be used for advertising a story for instance. Another opportunity is to transform the whole story into the base of an E-Learning adventure game where the media is used as game backgrounds and the successors serve as transitions. Certain XML documents and a game engine are in use [Moreno 08].

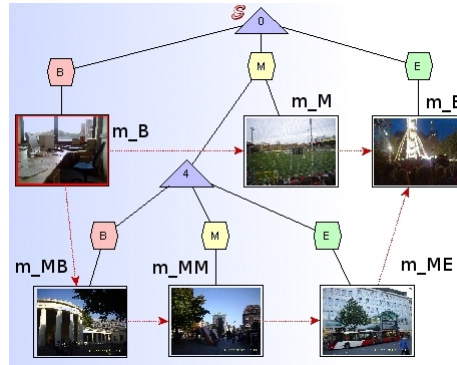

Figure 1: A Simple Story in MIST

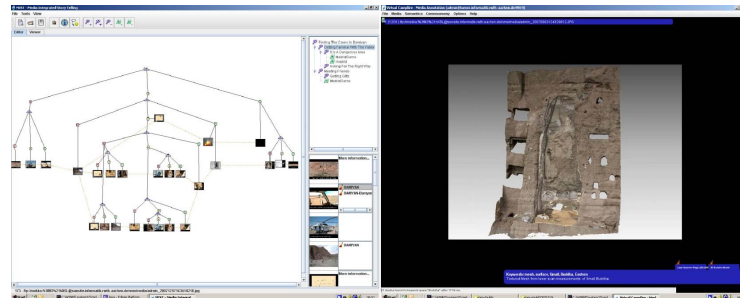
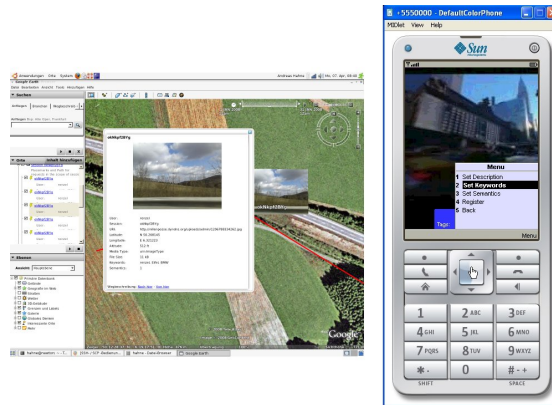

Figure 2: Annotated concept map

Yet, no complete mobile MIST version has been developed which is the only barrier on the way to the touristic guide in form of mobile non-linear story-telling. The design of mobile version of MIST is a challenging task. The restrictions of the mobile devices have to be considered to assure application usability.

Moreover, we will use a *Mobile Service Oracle for Success* (MobSOS) that measures the success of mobile multimedia community services [Renzel et al. 08]. As MobSOS tracks time and position of the service call, it can be applied for supplement the user action with additional semantical information. When taking pictures with NMV mobile, for instance, a tracked tour can be exported to the KML format used by Google Earth [Google Earth 08], providing the images and the tagged information as well. Figure 3 shows the interface of NMV mobile on the right-hand side and monitoring data displayed in Google Earth on the other side. The position information collected by MobSOS will be used to trace actions with close locations, which is the core idea of the aimed story-telling structuring.



**Figure 3:** Pictures in Google Earth Tagged with the NMV Mobile Interface

#### 4 Conclusions and Future Work

In this paper, we have presented a new evolutionary step of our story-telling environment MIST to its mobile non-linear version. We describe a concrete scenario to demonstrate the usefulness of our approach. Furthermore, we defined three already developed and deployed services. The mobile versions can be further integrated to get our proposed system later. In this paper, the current technical realization and the core concepts of each service were sketched.

We are currently working on the full mobile version of MIST. The media annotation tool is already implemented for mobile use and it produces media needed for the mobile story-telling approach. We are catching on many restrictions of mobile devices. We are performing a user-oriented conceptualization phase for the mobile MIST environment. Thereby, also the experience gathered during the development of MobsSOS will be useful.

#### Acknowledgment

This work is supported by the Excellence Initiative of German National Science Foundation (DFG) within the research cluster Ultra High-Speed Mobile Information and Communication (UMIC) and the DFG cluster project Context Adaptive Interaction in Cooperative Knowledge Processes (CONTICI). We are grateful to our colleagues Marc Spaniol and Baltasar Fernández Manjón for the inspiring discussions, also thanks to our students for the implementation.

## References

- [CITI 08] CITI-Project: “Interactive Personalized Mobile Story-telling”, *citi.di.fct.unl.pt/project/project.php?id=1*, 2008 (last access: 09.04.2008).
- [Google Earth 08] Google Earth: “Explore, Search and Discover” *earth.google.com* (2002) (last access: 09.04.2008).
- [Iurgel 05] Iurgel, I.: “Beneficial Dependencies: Design Principles for Narrative Games”; Subsol, Gérard (Ed.): *Virtual Storytelling – Using Virtual Reality Technologies for Storytelling (LNCS 3805)*, Proceedings, Berlin; Heidelberg: Springer (2005), pp. 209-218.
- [ISO 02] ISO/IEC: Information Technology “Multimedia Content Description Interface” Part 3: Visual. ISO/IEC 15938-2:2002, ISO (2002).
- [ISO 03] ISO/IEC: Information Technology “Multimedia Content Description Interface” Part 5: Multimedia description schemes. 15938-5:2003, ISO (2003).
- [iTour 08] iTour: “Die angenehmste Art Städte kennen zu lernen!”, *www.itour.de* 2008 (last access: 08.04.2008).
- [Klamma et al. 07] Klamma, R., Spaniol, M., Renzel, D.: “Community-Aware Semantic Multimedia Tagging – From Folksonomies to Commsonomies”, 7th MMC Workshop, I-Media 07 (5th September 2007).
- [Kuner 08] Project View, *mobilestorytelling.org* (2008) (last access: 09.04.2008).
- [Lambert 07] Lambert, J.: “Digital Storytelling Cookbook”; Digital Diner Press, San Francisco, California, USA (2007).
- [Mateas and Stern 05] Mateas, M. and Stern, A.: “Structuring Content in the Facade Interactive Drama Architecture”; Proceedings of Artificial Intelligence and Interactive Digital Entertainment (AIIDE 2005), Marina del Rey, (June 2005).
- [Moreno 08] <e-Adventure>: “Educational Adventure Games for Online Education”, *www.e-adventure.e-ucm.es* (2008) (last access: 25.03.2008).
- [Renzel et al. 08] Renzel, D., Klamma, R., Spaniol, M.: “MobsOS - A Testbed for Mobile Multimedia Community Services”, *9th International Workshop on Image Analysis for Multimedia Interactive Services (WIAMIS '08)*, May 7-9, 2008, Klagenfurt, Austria (2008).
- [Roth and Kleiner 99] Roth, G., Kleiner, A.: “Car Launch, The Human Side of Managing Change”; Oxford University Press, New York (1999).
- [Royrvik and Bygdas 02] Royrvik, E. A., Bygdas, A. L.: “Knowledge Hyperstories – The Use of ICT Enhanced Story-telling in Organizations”; The Third European Conference on Organizational Knowledge, Learning and Capabilities, Athens, Greece (2002).
- [Sharda 05] Sharda, N.: “Movement Oriented Design: A New Paradigm for Multimedia Design”. *International Journal of Lateral Computing (IJLC)*, 1(1):7-14, 2005.
- [Spaniol et al. 06a] Spaniol, M., Klamma, R., Sharda, N., Jarke, M.: “Web-Based Learning with Non-Linear Multimedia Stories”, International Conference on Advances in Web Based Learning (ICWL), 5 (2006), Penang.
- [Spaniol et al. 06b] Spaniol, M., Klamma, R., Janßen, H., Renzel, D.: “LAS: A Lightweight Application Server for MPEG-7 Services in Community Engines”, K. Tochtermann, H. Maurer (Eds.): Proceedings of I-KNOW '06, 6th International Conference on Knowledge Management, Graz, Austria, September 6 - 8, 2006, J.UCS (Journal of Universal Computer Science), Springer, pp. 592-599.
- [W3C 08] W3C Synchronized Multimedia; *www.w3.org/AudioVideo* (2008) (last access: 25.03.2008)
- [Wenger 98] Wenger, E.: “Communities of Practice: Learning, Meaning and Identity”; Cambridge University Press, UK (1998).

## Providing Multi Source Tag Recommendations in a Social Resource Sharing Platform

Martin Memmel, Michael Kockler and Rafael Schirru

(Knowledge Management Department  
DFKI GmbH, Kaiserslautern, Germany  
{mommel, kockler, schirru}@dfki.de)

**Abstract:** In today's information environments, tagging is widely used to provide information about arbitrary types of digital resources. This information is created by end users with different motivations and for different kinds of purposes. When aiming to support users in the tagging process, these differences play an important role. This paper discusses several approaches to generate tag recommendations, and a prototypical recommender system for the social resource sharing platform ALOE will be presented. This interactive system allows users to control the generation of the recommendations by selecting the sources to be used as well as their impact. The component was introduced at DFKI, and a first evaluation showed that the recommender component was considered as helpful by a majority of users.

**Key Words:** classification, collaborative tagging, digital resources, knowledge management, knowledge sharing, metadata, recommender, tagging, web 2.0

**Category:** H.3.0, H.3.2, H.3.3, H.3.4, H.3.5, H.5.0, H.5.1, H.5.2

### 1 Introduction

With the advent of the Web 2.0 social resource sharing platforms arose which allow their users to easily organize and share content. Well-known examples of such platforms are flickr<sup>1</sup> for photos and del.icio.us<sup>2</sup> for bookmarks.

In order to organize content for future search, navigation and filtering the users of such platforms assign tags (i.e., freely chosen keywords) to the resources in the system. As pointed out in [Golder and Huberman 2005], collaborative tagging is most useful when there is nobody in the "librarian" role or if there is just too much content for a single authority to classify. For the web, where collaborative tagging has grown popular in the recent years, both cases apply. Providing tag recommendations in such scenarios not only has the potential to supporting users in the tagging process, it can also help to reduce undesired noise in the folksonomy.

In this paper, we present an interactive approach to generate tag recommendations using different kinds of sources. The approach allows users to influence the tag recommendation process by offering them to choose from different sources

---

<sup>1</sup> <http://www.flickr.com/>

<sup>2</sup> <http://del.icio.us/>

and services to calculate the tag recommendations. Thus, it provides the possibility to adapt the recommendation outcome to the users' current needs.

The paper is structured as follows: section 2 describes the functions of tags, motivations for users to annotate tags as well as the resulting implications for tag recommenders. In section 3 we describe different sources for tag recommendations as well as criteria to measure the quality of tag recommendations. A prototypical implementation of a multi source tag recommender for the ALOE system as well as a short evaluation will be depicted in section 4. We then summarize our results and give an outlook on future work.

## 2 Why are people using tags?

Tagging is used in a variety of scenarios, and people tag for very different reasons. To understand how tag recommendations can help users in the tagging process, an understanding is required about what kinds of tags exist and what motivates people to tag.

### 2.1 Functions of tags

Tags can convey information about potentially any facet of a resource. This concerns information about the content and creation of a resource, about the way it should be or was used, etc. In [Golder and Huberman 2005], the following kinds of tags for resources are identified: *identifying what (or who) it is about*, *identifying what it is*, *identifying who owns it*, *identifying qualities or characteristics*, *self reference*, and *task organizing*.

Each of these purposes requires different kinds of tag recommendations, generated by using different kinds of sources. E.g., the content of a resource can be used to identify entities in a resource and thus to suggest keywords that describe what or who it is about, whereas it makes almost no sense to use such information for task organizing or to identify qualities or characteristics.

### 2.2 What motivates people to tag?

As we have shown, people use tags for different purposes. But not only the purposes of tags have to be considered. The motivation of users to tag resources also has to be considered. Marlow et al. identified the following criteria: *future retrieval*, *contribution and sharing*, *attract attention*, *play and competition*, *self presentation*, and *opinion expression* [Marlow et al. 2006].

It is obvious that different kinds of tag recommendations should be offered for different kinds of motivations. Whereas tag recommendations derived from the analysis of the resource content will be useful in most cases, they won't be helpful when users want to express their opinions. The way existing tags should

be taken into account also depends on the users' motivations. E.g., support for users that want to attract attention should take into account existing, popular tags from the whole system, whereas mainly the tagger's existing tags should be taken into account to support future retrieval or self presentation.

### 2.3 Implications for tag recommenders

We have seen that the way tag recommendations should be generated strongly depends on what kind of tag shall be used and for which reason. Thus, a one-size-fits-all solution is not adequate. It should be possible to adapt a recommender system to a variety of usage scenarios. As it is rather unlikely that the recommender knows in advance about what characterizes the current scenario, the user should have the possibility *to decide which sources to use for recommendations, to determine the impact the different sources should have, and to decide whether the recommended tags should be restricted to a certain vocabulary*, e.g., the user's own tags or the tags already existing in a system.

As a recommender component with that many features might become very complex and requires some knowledge and expertise about how recommendations are generated, it might not necessarily be useful to provide it to arbitrary end users in any kind of tagging system. Yet, it might be very useful to provide it to a restricted group of users, or to a community manager or admin to specify values that best correspond to the characteristics of the community and content in the according system. These settings can then be used for a reduced version of the tag recommender with less complex interaction possibilities that can be made available for all end users.

## 3 Generating recommendations

A variety of sources can be used to generate tag recommendations. This not only concerns the content of a resource, but also existing metadata, information about usage contexts, etc. After examining by which means tag recommendations can be created, we will then discuss what constitutes good tag recommendations.

### 3.1 Available sources for tag recommendations

As shown in Figure 1, one can distinguish four different knowledge sources that can have an impact on the generation of tag recommendations: the tagging *user*, the *system* providing the tagging facility, the *resource* to be tagged and *background knowledge*. In the following, each of these knowledge sources will be examined briefly.

First, information from and about the user who wants to tag a resource can be taken into account. This includes the tags already used, tags used by the user's

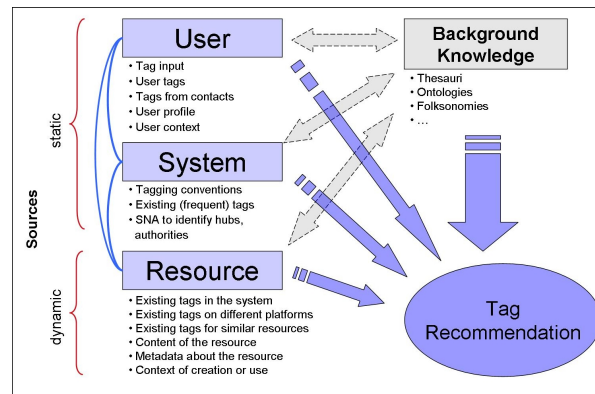

**Figure 1:** Potential sources for tag recommendations [Kockler 2008]

contacts, information that can be drawn from the user's profile (e.g., containing information about interests), and information about the current context of the user (e.g., gathered with user observation components).

Secondly, the system for which the recommendations shall be provided can play an important role. In case such a system uses certain tagging conventions (e.g., multi-word terms can be used as tags using quotation mechanisms), this has to be taken into account. Furthermore, information about popular tags can be used as a source, and social network analysis can provide additional information about the users of the system (e.g., identifying them as hubs or authorities) that can be used to estimate the quality of existing contributions.

Thirdly, the resource itself can be examined. Using techniques from the fields of Information Extraction and Natural Language Processing, information about the content of the resource (e.g., concepts such as topics, people or organizations) can be derived. Furthermore, existing tags and additional metadata about the resource (e.g., containing information about the context of use) can be taken into account.

Last but not least, a tag recommender can make use of background knowledge in the form of thesauri, ontologies or folksonomies. Such information can be used, e.g., to find similar or related tags in the recommendation process.

### 3.2 Quality of tag recommendations

As argued in section 2, the reason tags are used strongly depends on a user's motivation and the context of use. Thus, the quality of tag recommendations also depends on these factors. E.g., a recommendation might be very useful to describe the topic of a resource, but almost useless when users want to express



their relations to the resource. In this case, existing tags already used in such a context would be helpful. Nevertheless, we would always consider a tag recommendation as bad when it does not provide valuable information for any kind of usage scenario, e.g., if a tag was recommended that is not related to the resource.

When existing tags will be recommended, one also has to consider what is sometimes denoted as the *echo chamber effect* [Jamieson and Cappella 2008]. This effect turns up when popular tags from the head of the long tail of tags (see [Anderson 2006, Barnett 2006]) will be recommended very often, thus causing that the respective tags become even more popular. On the one hand, this can be considered as positive, as the usage of the same tags for resources fosters that more potentially relevant resources can be found when searching for the respective tag (positive impact on recall). On the other hand, the usage of a diversity of tags allows for more subtle distinctions (positive impact on precision). Marlow et al. therefore distinguish *blind tagging* where a user does not see the tags which have been assigned to the same resource by other users, *viewable tagging* where users can see these tags, and *suggestive tagging*, where the system suggests possible tags to the user [Marlow et al. 2006].

## 4 Multi source tag recommendations in ALOE

Before presenting the prototypical realization of the multi source tag recommender, we will first introduce the ALOE system in which it was embedded. We will conclude this chapter with the results of a first evaluation.

### 4.1 The ALOE platform

ALOE<sup>3</sup> is a social media sharing platform currently being developed at the Knowledge Management Department of DFKI<sup>4</sup>. ALOE offers possibilities to share digital resources and arbitrary information about them. It provides a rich user interface and allows access to data and functionalities via a Web service API. ALOE allows to upload and share arbitrary types of digital resources, and to share and organize bookmarks. It also provides common social media functionalities such as tagging, rating, and commenting, groups can be initiated, users can communicate with each other, etc. See [Mommel and Schirru 2007] for more details about functionalities, use cases and the system architecture.

### 4.2 The multi source tag recommender

The interface of the prototypical implementation of the multi source tag recommender is shown in Figure 2. First, users have to enter the URL of the resource

<sup>3</sup> see <http://aloe-project.de/>

<sup>4</sup> funding for the development within the project CoMet (see <http://www.dfki.uni-kl.de/comet/>) was provided by the “Stiftung Rheinland-Pfalz für Innovation”

they want to tag. Using the Recommender Mixing Desk, users can choose the source from which the recommendations shall be derived. Available sources are *the content of the resource*, *metadata about the resource* that has been published in ALOE (this concerns the usual ALOE metadata as well as external metadata sets such as FM-XML from KMi, OU that is associated with public FM replays published in ALOE), *the usage context of the resource* that has been gathered with selected user observation components developed at DFKI (see [Kiesel et al. 2008] for more details), and *existing tags* for the resource from different sources.

By using the sliders, users can decide which impact each source will have in the tag recommendation process. In the box below, the information extraction services which shall be used to extract the entities that appear in the considered resource can be selected. Services that can be used here are Semager<sup>5</sup>, Yahoo!<sup>6</sup>, TagTheNet<sup>7</sup> and ALOA<sup>8</sup>. Stemming can optionally be applied to the keywords that have been determined that way. If existing tags shall be used, users can select tags of the resource in ALOE, tags that the user's contacts have used, and the tags which have been assigned to the resource in del.icio.us. The third box on the page allows to specify for each selected source whether related tags shall be taken into account to generate the tag recommendations. If this is the case then also the services which have to be used to determine related tags have to be specified. Available services are: Semager, Yahoo!, WordNet<sup>9</sup>, MobyThesaurus<sup>10</sup> and Watson<sup>11</sup>.

After choosing sources and services, the generation of a recommendation cloud can be initiated. The size of the tags in the cloud corresponds to the relevance that has been determined for the respective tag. Tags in the recommendation cloud can be restricted to tags from the users themselves, their contacts, or tags in ALOE by applying different filters. In the bottom of the page, the results for each different source are shown to provide information about the impact they had.

### 4.3 A first evaluation and results

In a first evaluation at DFKI, 15 users were asked to try out the recommender with three specified resources as well as with arbitrary resources they could choose freely. They then had to fill out a questionnaire to provide feedback. 10 users were already familiar with tagging, mainly using it for "future retrieval"

<sup>5</sup> <http://www.semager.de/api/textcloud>

<sup>6</sup> <http://developer.yahoo.com/search/content/V1/termExtraction.html>

<sup>7</sup> <http://www.tagthe.net/>

<sup>8</sup> <http://eiche.informatik.rwth-aachen.de:3333/ALOInterface/index.jsp>

<sup>9</sup> <http://wordnet.princeton.edu/>

<sup>10</sup> <http://www.mobysaurus.com/>

<sup>11</sup> [http://watson.kmi.open.ac.uk/WS\\_and\\_API.html](http://watson.kmi.open.ac.uk/WS_and_API.html)

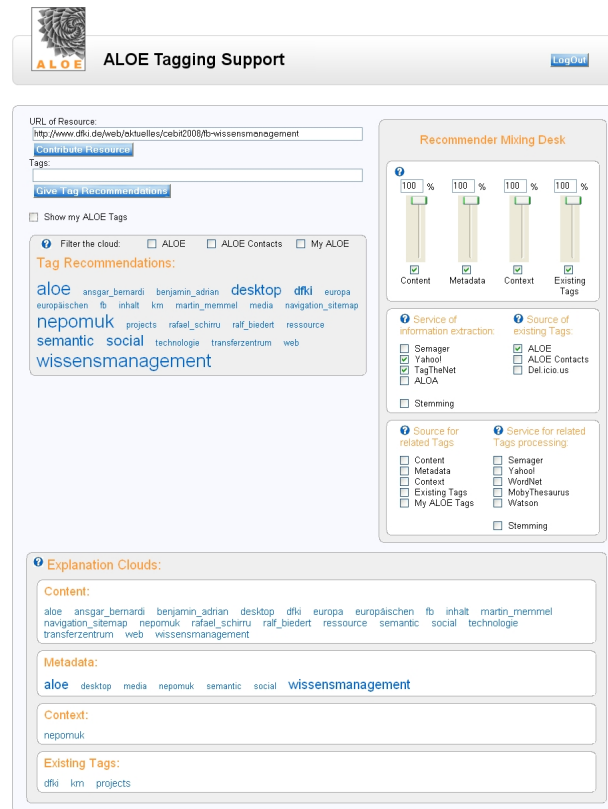
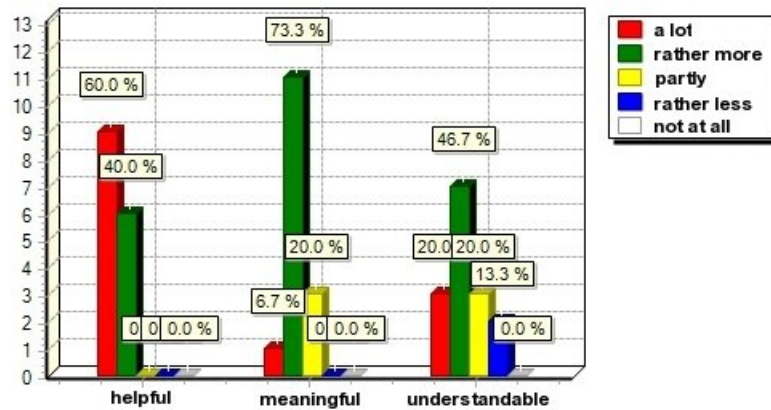

**Figure 2:** A screenshot of the multi source tag recommender interface

and “contribution and sharing”. Figure 3 shows that the vast majority of users considered the recommendations as meaningful and helpful. Furthermore, the evaluation showed that the selection of sources as well as information extraction services has a huge impact on the user’s satisfaction with the recommended tags.

## 5 Summary and future work

Supporting users in the tag generation process requires an understanding of the nature of tags as well as the users’ motivations to tag a resource. Thus, a respective recommender component must be adaptable to different usage scenarios. We therefore suggested a tag recommender that allows users to select the sources as well as the impact of these source for the recommendation process. A first prototype of the system was developed as part of the ALOE system, and a first evaluation showed that the recommendations were considered as meaningful and



**Figure 3:** Evaluation results for the quality of recommended tags

helpful by a majority of users. In the future, we plan to use the full version with all interaction possibilities mainly as a tool for experts within ALOE. Meaningful settings that correspond to the characteristics of users, resources, tags, and additional metadata can thus be determined and used for a reduced version of the tag recommender with less complex interaction possibilities that will be made available for all end users of the system.

## References

- [Anderson 2006] Anderson, C.: “The Long Tail”, Random House Business Books, 2006.
- [Barnett 2006] Barnett, A.: “The Long Tail of Tags”, 2006, electronic document date of publication: September 16, 2006. Retrieved April 27, 2008, from <http://alexbarrett.net/blog/archive/2006/09/16/The-Long-Tail-of-Tags.aspx>.
- [Golder and Huberman 2005] Golder, S.; Huberman, B.A.: “The Structure of Collaborative Tagging Systems”; HP Labs, 2005.
- [Jamieson and Cappella 2008] Jamieson, K. H.; Cappella, J. N.: “Echo Chamber: Rush Limbaugh and the Conservative Media Establishment”, Oxford Univ. Press, 2008.
- [Kiesel et al. 2008] Kiesel, M.; Schwarz, S.; van Elst, L.; Buscher, G.: “Using Attention and Context Information for Annotations in a Semantic Wiki”; 3rd Semantic Wiki Workshop, co-located with the 5th European Semantic Web Conference (ESWC), Spain, June 02, 2008 (to appear).
- [Kockler 2008] Kockler, M.: “Conception & Implementation of Tagging Support Mechanisms in a Web 2.0 Social Media Sharing Platform”; Diploma Thesis, Technische Universität Kaiserslautern, DFKI, 2008.
- [Marlow et al. 2006] Marlow, C.; Naaman, M.; Boyd, D.; Davis, M.: “HT06, Tagging Paper, Taxonomy, Flickr, Academic Article, ToRead.”; Proceedings of Hypertext 2006; New York: ACM Press, 2006.
- [Mommel and Schirru 2007] Memmel, M.; Schirru, R.: “Sharing Digital Resources and Metadata for Open and Flexible Knowledge Management Systems”; in Klaus Tochtermann and Herrmann Maurer, editors, Proceedings of I-KNOW 2007, Journal of Universal Computer Science, pages 41–48. Graz, Austria, 2007.

## **What's the Power behind 2D Barcodes? Are they the Foundation of the Revival of Print Media?**

**Paul Schmidmayr**

(Graz University of Technology, Graz, Austria  
paul.schmidmayr@gmx.at)

**Martin Ebner**

(Graz University of Technology, Graz, Austria  
martin.ebner@tugraz.at)

**Frank Kappe**

(Graz University of Technology, Graz, Austria  
fkappe@tugraz.at)

**Abstract:** 2D barcodes are capable of storing different kind of data. A significant number of new mobile phones come with a built-in camera. These technologies together with the fact that mobile phones are next to the owner most of the time are the foundation of a variety of interesting applications. In Japan more than 75% of all mobile phones do have already a pre-installed barcode reader, that allows the user to decode the incorporated information of a barcode. This procedure can be used to improve the user experience while simplifying the input of data into the mobile device. These 2D barcodes can be used to exchange information between mobile phones and to connect to the mobile web. These days the Western World is gaining interest in this technology. In this paper the most important applications are introduced. The relevance to print media and the advertising industry is shown.

**Keywords:** ad tracking, Datamatrix, 2D barcodes, QR Codes, mobile phone, mobile tagging

**Categories:** L.1, L.7, H.3, H.5, K.4

### **1 Introduction**

1D barcodes are already ubiquitous as they can be found on the packaging of virtually any product. 2D barcodes or matrix codes are symbologies that are capable of storing more data than 1D barcodes.

Mobile phones are another technology that is becoming ubiquitous in the developed countries. Also the number of devices with built-in cameras and internet connectivity is increasing rapidly.

The merge of these two technologies allows the link from the physical to the digital world in a simple way.

In this context 2D barcodes are also called "mobile tags", and are placed on e.g. physical objects, that for additional information will be provided on a web page.

Mobile Tagging is the process of [Fig.1]:

- 1) capturing the image of the barcode with the camera-equipped mobile phone
- 2) decoding the image using a software program, called barcode reader
- 3) linking to the decoded URL on the world wide web to get more information.



Figure 1: Graphical illustration of the process "mobile tagging" [Wiki08]

This approach is an inexpensive and an easy to use solution to several problems:

Mobile phones are used most of the time just by the owner and serve through the wide range of functionalities (e.g. phonebook, organizer, ..) as personal assistants.

An unsatisfying user experience in dealing with mobile devices is the entry of data. Instead of typing the data key by key, 2D barcodes are one solution to this task.

Using the barcode reader application, scanning and storing of the e.g. contact details of a conference participant is a task of pressing a couple of keys. Also date, location and description details of events can be saved to the organizer this way.

While reading the newspaper several articles come with hyperlinks providing further information. Very often the personal computer is not nearby (e.g. in the bus or train, ...). Even the content would be of interest to the reader it is less likely that the content will not be checked out. Using the mobile phone which is in reach at any time accessing the link immediately or at least saving it to the bookmarks for use at a convenient time becomes easy.

The link from print media to the World Wide Web brings several advantages to the end user and the publisher as well.

The main purpose of this paper is to give an overview how to use 2D barcodes in print media and on advertising billboards to get more accurate estimates about the interest of the targeted audience. The advantages of ad tracking and opting in to build a relationship with the potential customer, already common on the World Wide Web are becoming available to the physical world as well.

## 2 Types of 2D barcodes

Meanwhile there do exist more than 1000 different barcodes. More than 100 of them are 2D barcodes.

The number of 2D barcodes used for mobile tagging is around twelve different ones [MoTag07]. In [Kato05] nine criteria were outlined that should be fulfilled by a standard 2D barcode for applications (e.g. mobile payment) with mobile phones. Also several barcodes have been developed especially for the use of mobile tagging none of the surveyed code satisfied all criteria. The outcome of this research selected VSCoDe™ [VSCoDe02] as the best choice as a standard 2D barcode for this purpose. But considering which barcodes and barcode readers are mentioned more often on websites dealing with this topic, VSCoDe does not seem to play a very important role currently.

In [Fig.2] an overview of relevant mobile tagging barcodes is given.



Figure 2: Overview of relevant mobile tagging barcodes [Wiki08]

## 2.1 QR-Code

QR-Code [ISO18004] was developed by the Japanese cooperation Denso Wave [Denso03] in 1994. QR-Code (“Quick Response”) is the de facto standard for Japanese telecommunication providers and handset vendors. 3G Vision’s [3G Vision] barcode reader decodes QR-Codes and is installed on 75% of Japanese handsets.

### 2.1.1 Micro QR-Code

Micro QR-Code is distinct smaller than the original QR-Code. The capacity is very limited(maximum 35 numeric characters or 21 alphanumeric characters). A barcode reader decoding QR-Codes is not necessarily able to decode Micro QR-Codes.

## 2.2 Data Matrix

Data Matrix [ISO16022] was developed and standardized by NASA, Department of Defense and several other companies. The Consumer Electronics Association, R9 Automatic Data Capture Committee, did a comparison of the Data Matrix and the QR-Code and decided that there is no necessity to include the QR-Code as a permitted symbology. The comparison has shown that Data Matrix is the most space efficient of all the two-dimensional symbologies. At that time, 2001, it was the most widely implemented 2D barcode in the greatest diversity of applications and industries. No significant advantage of the QR-Code over the Data Matrix has been stated [CEA01]. The QR-Code was developed to allow the decoding of Japanese Kanji-characters and this feature has no relevance in the Western World .

## 2.3 Proprietary Codes

[Semacode06] compares Data Matrix vs. proprietary codes. In the discussion the expertise of the developers of proprietary codes in comparison to the industry driven development of Data Matrix is questioned. The availability of technical specifications and the width of industry support are mentioned as an argument for the standardized

format. The reliance on a single vendor involves risks in case of a change in his business model or a close down. Proprietary codes may have limited capacity to store data. The reason behind may be, that the vendor wants to act as a required middleware service provider.

While the standardized codes will probably get support from manufacturers of mobile phones, this will most likely not be the case for proprietary codes.

### *Beetagg*

Beetags have been optimised to address some issues of the Western mobile market [Beetagg08]. E.g. in Japan most mobile phones are equipped with an autofocus and/or a macro functionality. This is not the case in the Western World so the scanning of small printed codes is not possible.

Beetagg is designed, to overcome this issue, so that the mark could be encoded without autofocus and/or a macro lens.

Beetagg allows the placement of a logo for branding in the middle of the symbol. The developing company states that this is an advantage over the two standardized barcodes mentioned above. Even the standard does not provide the possibility of branding. But also the opportunity of branding is not included in the standards, there are already QR-Codes and Data Matrix codes holding a logo in the centre.

Some other proprietary codes for mobile tagging: Aztec [AIM], [Cybercode00], [Ezcode07], [mCode], [Quickmark], [Shotcode08], [Trillcode], [UpCode].

To emphasize the importance of barcodes, it should be mentioned, that Google launched Zxing [Zxing07], which is an open-source, multi-format 1D/2D barcode reader library implemented in Java. It is also part of Android [Android08], a project of the Open Handset Alliance [OHA], the first open and free mobile platform.

Barcodes are also a research topic at Microsoft Research [Microsoft].

## **3 Mobile tags and camera equipped mobile phones**

To make use of mobile tags first of all a camera-equipped mobile phone is necessary. At the current time only very few handsets in the mobile market outside Asia come with a built-in barcode reader, a software program that decodes the data from the two-dimensional symbology. These built-in programs in most cases can only handle Data Matrix code and/or QR-Codes. Different barcode readers are downloadable via the World Wide Web [I-Nigma08] [Kaywa08] [Neoreader08] [Nokia].

Someone can download the barcode reader directly to his mobile phone via UMTS, GPRS or wireless LAN. Otherwise the downloaded program can be transferred from the PC to the handset through a cable link, bluetooth or infrared connection.

Mobile tags can be created by everyone very easily with free resources on the World Wide Web [I-Nigma08] [Kaywa08] [Neoreader08] [Nokia]. For some proprietary barcodes the creation of codes and keeping them active requires a monthly fee.

The following list provides examples of incorporated data and its distribution:



*personal use:*

- simple text
- printed on business card to save contact details in phone book [Dawson98a]
- date, location and description of events or appointments to save into the organizer [Dawson98b]
- entering phone number
- subscribing to RssFeed
- data exchange direct from the display of one mobile phone to another one
- printed on clothing (T-shirt [FacebookApp], bags,...)
- Tattoo

*general or commercial use:*

- URL (coupons, incentives, mp3-, video download)
- predefined email or sms
- printed (e.g. newspaper, magazine, flyer)
- billboards
- flatscreens
- mobile payment
- special applications

Extracting the encoded data is very simple and takes only a couple of keystrokes.

To decode a barcode, the barcode reader application has to be launched on the mobile device and the barcode will be decoded when focusing the camera on the symbology.

In the field deployment of the AURA system (Advanced User Resource Annotation) [Brush05] the usage of a mobile device in conjunction with an external barcode reader was observed. Users of the AURA system are able to enter or check comments, recommendations and other additional information for a specific product. Since the mobile phone together with the integrated camera is part of every day life and no additional device is needed, the usage may be more likely.

## **4 Applications of barcodes related to print media**

Some projects using mobile tags, which launched recently:

1. The newspaper "Welt Kompakt" [Welt07] was the first one that introduced QR-Codes in the German-speaking countries. For several printed articles it is possible for the reader to get additional information on these topics following a link to mobile content through that is encoded in a QR-Code
2. Spektacle.com [Spek07] is the first QR-Code magazine in the Western World based in Great Britain. The magazine is issued bi-monthly, but the online content is updated more often. The magazine focuses on design, fashion and music. Some integrated QR-Codes allow the purchase of an advertised product via the mobile phone.

3. Recently Google launched the Google Print Ads platform [GoogleAd07] to manage the run of an ad in several newspapers of the United States online. Google also supports the use of QR-Codes within these print ads [Google07]

The main purpose of 2D barcodes in print media is to provide additional content. Additional information can be provided e.g. in form of multimedia, like animations to clarify some process, interviews via mp3-files, competition or simple games.

It will also be easier to allow the reader to participate and generate content, which is also one pillar of Web2.0 [OReilly05]. (user votings or comments).

At Graz University of Technology some research work is done by using QR-Codes. Perhaps the most interesting one is dealing with tracking conventional advertisement. Till now ad tracking was reserved for online marketing in the World Wide Web. With the use of 2D barcodes in print media it becomes possible to get better estimates about the consumed content. Which kind of additional content is checked out, will give a more accurate view of the readers wants. Also this method allows determining, at which time of the day which content is consumed.

Thinking of advertisements on billboards, passer-by could be offered an incentive to scan the code, like a coupon. With this method the quality of the location for the advertisement can be determined.

For this setting each advertisement would show a different 2D barcode, encoded a unique URI. This URI is looked up in a database, which holds the link to the targeted website and the description of the location of the billboard where the advertisement is shown. The content of the targeted website is sent to the users mobile phone automatically. Currently the first tests with a prototype are running.

## **5 Discussion**

Mobile technology is still in progress and there are some issues to be solved.

- 1) The procedure of mobile tagging is a very convenient and easy way to deal with entering data into the mobile phone and improves the mobile user experience.
- 2) The mobile phone is next to the owner most of the time and also used rarely by someone else it is dedicated to serve as personal assistant. Therefore it is necessary to find a way to ease the input of personal contacts, events and other information.
- 3) For publisher of newspaper and magazines it provides the possibility to get accurate estimates about behaviour of the readers.
- 4) Now billboards become a mean to start a dialog with a prospect.
- 5) Data Matrix and QR-Codes are standardized codes but there is no guideline for the „internal structure“ of the encoded data. On December 17, 2007 Mobile Codes Consortium announced the commitment of the GSM Association [GSMA] and the Open Mobile Alliance [OMA], to drive worldwide barcodes standards
- 6) Older models of mobile phones with built-in cameras do not always allow to encode especially smaller printed 2D barcodes. Newer handset models equipped with autofocus and/or macro lenses are a part of the solution.
- 7) The number of different codes and the requirement of the installation of different barcode readers seems to stand in the way of the take-off of this technology.
- 8) Barcodes on advertisements can be replaced by an other ones.
- 9) Connecting to the Internet via mobile phone is still very.

## 6 Conclusions

This paper discusses the importance of 2D barcodes and their usage and impacts for print media and advertising. Mobile phones are converging to personal assistants which are storing essential personal data and they are next to the owner most of the time. It can be observed that the costs of the Internet access via mobile phones are becoming achievable and this eliminates the barrier of the price tag.

Organizations are taking efforts to set a standard for the use and the format of the incorporated data of mobile barcodes.

2D barcodes provide a mean to simplify the data entry to mobile phones in terms of a more convenient user experience. Mobile tags in conjunction with an appropriate infrastructure allow the tracking of ads and collecting accurate data about the interest of a targeted audience. This can be used to improve the relationship to the reader.

The link between print media and World Wide Web is the next big step in the digital world.

## References

- [3G Vision] <http://www.3gvision.com/prod-code-reader.htm> (last visited: 10.4.2008)
- [AIM] <http://www.aimglobal.org/standards/matrixsymbolologies.asp> (last visit: 12.4.2008)
- [Android08] <http://code.google.com/android> (last visited: 10.4.2008)
- [Beetagg08] <http://www.beetagg.com> (last visited: 10.4.2008)
- [Brush05] Brush, A.J.B., Turner, T.C., Smith, M.A., Gupta, N. 2005. Scanning Objects in the Wild: Assessing an Object Triggered Information System, UbiComp 2005.
- [CEA01] "Comparison of Data Matrix and QR Code", Consumer Electronics Association, R9 Automatic Data Capture Committee,  
[http://www.autoid.org/2001\\_documents/ANSI/ANSI\\_WG6/R9\\_Neg\\_IEC62090\\_5thCDV\\_0701.doc](http://www.autoid.org/2001_documents/ANSI/ANSI_WG6/R9_Neg_IEC62090_5thCDV_0701.doc) (last visited: 10.4.2008)
- [Dawson98a] Dawson, F. and Howes, T., vCard MIME Directory Profile. Internet RFC 2426, September 1998.
- [Dawson98b] Dawson, F. and Stenerson, D., Internet Calendaring and Scheduling Core Object Specification (iCalendar). Internet RFC 2445, November 1998.
- [Denso03] <http://www.denso-wave.com/qrcode/index-e.html> (last visited: 10.04.2008)
- [EzCode07] <http://www.ezcode.com.sg/home.aspx> (last visited: 10.4.2008)
- [Falas07] Falas, T. and Kashani, H. 2007. Two-Dimensional Bar-Code Decoding with Camera-Equipped Mobile Phones. In *Proceedings of the Fifth IEEE international Conference on Pervasive Computing and Communications Workshops* (March 19 - 23, 2007). PERCOMW. IEEE Computer Society, Washington, DC, 597-600.
- [FacebookApp] <http://www.facebook.com/apps/application.php?id=21352510322> (last visited: 12.04.2008)
- [Gao07] Gao, J. Z., Prakash, L., and Jagatesan, R. 2007. "Understanding 2D-BarCode Technology and Applications in M-Commerce - Design and Implementation of A 2D Barcode

Processing Solution". In *Proceedings of the 31st Annual international Computer Software and Applications Conference - Vol. 2- (COMPSAC 2007) - Volume 02* (July 24 - 27, 2007). COMPSAC. IEEE Computer Society, Washington, DC, 49-56

[Google07] <http://www.google.com/adwords/printads/ads/barcode> (last visit: 10.4.2008)

[GoogleAd07] <http://www.google.com/adwords/printads/index.html> (last visit: 10.4.2008)

[CyberCode00] Rekimoto, J. and Ayatsuka, Y. 2000. CyberCode: designing augmented reality environments with visual tags. In *Proceedings of DARE 2000 on Designing Augmented Reality Environments* (Elsinore, Denmark). DARE '00. ACM, New York, NY, 1-10.

[GSMA] <http://www.gsmworld.com/index.shtml> (last visited: 10.4.2008)

[I-Nigma08] <http://i-nigma.com/personal> (last visited: 10.4.2008)

[ISO16022] ISO/IEC 16022:2006. Information technology - Automatic identification and data capture techniques - Data Matrix bar code symbology specification

[ISO18004] ISO/IEC 18004:2006(E). Information technology – Automatic identification and data capture techniques – QR Code 2005 bar code symbology specification

[Kato05] Kato, H. and Tan, K.T., "2D barcodes for Mobile Phones", *Proceedings of 2nd International Conference on Mobile Technology, Applications and Systems*, pp.8, Nov. 2005.

[Kaywa08] <http://reader.kaywa.com> (last visited: 10.4.2008)

[Mcc07] <http://www.mobilecodes.org> (last visited: 10.4.2008)

[mCode] <http://www.connexto.com/Index.aspx> (last visited: 10.04.2008)

[Microsoft] <http://research.microsoft.com/research/hccb/about.aspx> (last visited: 10.04.2008)

[MoTag07] [http://mobile-tagging.blogspot.com/2007/06/windows-surface-und-die-zukunft-der-2d\\_05.html](http://mobile-tagging.blogspot.com/2007/06/windows-surface-und-die-zukunft-der-2d_05.html) (last visited: 11.04.2008)

[Neoreader08] <http://neoreader.com/home.html> (last visited: 10.04.2008)

[Nokia] <http://mobilecodes.nokia.com/scan.htm> (last visited: 12.04.2008)

[OHA] <http://www.openhandsetalliance.com/> (last visited: 10.04.2008)

[OMA] <http://www.openmobilealliance.org> (last visited: 10.04.2008)

[OReilly05] <http://www.oreillynet.com/pub/a/oreilly/tim/news/2005/09/30/what-is-web-20.html> (last visit: 12.04.2008)

[Pavlidis00] Pavlidis, T., "A New Paper/Computer Interface: Two-Dimensional Symbologies," *icpr*, p. 2145, 15th International Conference on Pattern Recognition (ICPR'00) - Volume 2, 2000.

[Quickmark] <http://www.quickmark.com.tw/En/info/about.asp> (last visited: 10.4.2008)

[Semacode06] Choosing the best 2D barcode format for mobile apps, Technical white paper, Semacode, 2006

[Shotcode08] <http://www.shotcode.com> (last visited: 10.4.2008)

[Spek07] <http://www.spektacle.com> (last visited: 08.04.2008)

[Trillcode] <http://www.trillcode.com/> (last visited: 12.04.2008)]

[UpCode] <http://www.upc.fi/en/upcode> (last visited: 12.04.2008)

[VSCo02] Veritec Iconix Ventures Inc. 2002. "The New 2D Matrix Code, VSCODE™"  
<http://www.vi-vi.com/english/catalogue/VS-Catalogue.pdf> (last visited: 10.4.2008)

[Welt07] <http://www.welt-kompakt.de> (last visited: 08.04.2008)

[Wiki08] [http://en.wikipedia.org/wiki/Mobile\\_tagging](http://en.wikipedia.org/wiki/Mobile_tagging) (last visited: 12.04.08)

[Zxing07] <http://code.google.com/p/zxing/> (last visited: 10.04.2008)

## Building Tagged Linguistic Unit Databases for Sentiment Detection

**Arno Scharl**

(MODUL University Vienna, Austria  
arno.scharl@modul.ac.at)

**Albert Weichselbraun**

(Vienna University of Economics and Business Administration, Austria  
albert.weichselbraun@wu-wien.ac.at)

**Stefan Gindl**

(MODUL University Vienna, Austria  
stefan.gindl@modul.ac.at)

**Abstract:** Despite the obvious business value of visualizing *similarities* between elements of evolving information spaces and mapping these similarities e.g. onto geospatial reference systems, analysts are often more interested in how the *semantic orientation (sentiment)* towards an organization, a product or a particular technology is changing over time. Unfortunately, popular methods that process unstructured textual material to detect semantic orientation automatically based on tagged dictionaries [Scharl et al. 2003] are not capable of fulfilling this task, even when coupled with part-of-speech tagging, a standard component of most text processing toolkits that distinguishes grammatical categories such as article (AT), noun (NN), verb (VB), and adverb (RB). Small corpus size, ambiguity and subtle incremental change of tonal expressions between different versions of a document complicate the detection of semantic orientation and often prevent promising algorithms from being incorporated into commercial applications. Parsing grammatical structures, by contrast, outperforms dictionary-based approaches in terms of reliability, but usually suffers from poor scalability due to their computational complexity. *This paper* addresses this predicament by presenting an alternative approach based on automatically building *Tagged Linguistic Unit (TLU)* databases to overcome the restrictions of dictionaries with a limited set of tagged tokens.

**Key Words:** sentiment detection, semantic orientation, tagged linguistic unit

**Category:** I.2.7, I.2.7, E.m

### 1 Introduction

The field of *Sentiment Detection* is an intriguing one, since the revelation of the semantic content of a written text shows the real opinion and meaning of the writer. This information can be used for several reasons: enterprises can research on the question, why a certain product failed a success in the market, in politics this knowledge can be used to predict the electoral behavior to adapt the political course or search engines can profit from these methods to augment search results.

The detection of the semantic content of writings has fascinated many researchers, leading to a vast amount of different approaches to absolve this task. Some of these only use binary decisions (a positive or negative sentiment), others use more sophisticated classifications.

Pang et al. [Pang et al. 2002] present an approach using movie reviews as text corpus. The basis for the sentiment detection builds a manually annotated lexicon. The authors use machine learning methods, i.e. Naïve Bayes, maximum entropy and support vector machines (SVMs), and the SVM performed best. The approach is refined in their subsequent work [Pang and Lee 2004]. Kushal et al. [Kushal et al. 2003] apply three machine learning methods to product reviews, comparing their results to a baseline algorithm. In the baseline algorithm, the score of a term is decided by the number the term occurs in a class divided by all terms in this class.

The polarity of the context, in which a sentiment term occurs, influences the significance of this term [Wilson et al. 2005] - e.g., in ‘...the president of the National Environment Trust...’, with ‘trust’ a large enterprise is meant and not the synonym for ‘confidence’. They use a set of 28 features, such as modifiers or adjacent terms, to determine the context’s polarity.

Subasic and Huettner [Subasic and Huettner 2001] use a lexicon to ascertain the semantic orientation of a document. They discriminate a word’s meaning by focusing on three features: the *affect* class a word belongs to is decided via part-of-speech tagging (e.g., ‘alert’ as an adjective targets *intelligence*, whilst as a verb it targets *warning*). The feature *centrality* shows how strongly a word belongs to the affect class, whereas the *intensity* represents the strength of a word (e.g., ‘abhor’ is stronger than ‘displeasure’, but both belong to the affect ‘repulsion’). The words are aggregated in a fuzzy thesaurus (using max-min combination) and the overall sentiment is calculated via the weighted average of the occurring terms of each class and their intensities. Mullen and Collier [Mullen and Collier 2004] work on SVMs, processing music reviews. The semantic wordlist contains three dimensions: *potency* (representing the strength of a term), *activity* (active or passive) and *evaluation* (positive or negative).

Lexical entries can also be distinguished from each other by using so called ‘appraisal taxonomies’ [Whitelaw et al. 2005]. These contain information on the attitude of a word (e.g., ‘appreciation’ or ‘affect’), the ‘orientation’ (positive vs. negative), the ‘force’ (can be increased by modifiers like ‘very’), or the ‘polarity’ (a binary decision depending on the existence of a negation trigger).

## 2 Lexical Approaches versus Shallow Parsing

Capturing the evolution of information spaces calls for a new generation of robust, language-independent and distributed natural language processing tech-

niques optimized for throughput and scalability. From a stakeholder perspective, the semantic orientation expressed in textual material (e.g., media coverage) is a particularly interesting aspect when identifying semantic relations [Scharl and Weichselbraun 2006]. Automated methods to compute semantic orientation, however, usually belong to one of the following two categories: (i) full parsing of grammatical structures implicates in good results, but suffers from poor scalability; (ii) simple, scalable methods that focus on the lexis of text but, compared to the first category, fall short in terms of reliability and validity. This paper presents an alternative approach based on automatically generated databases of *tagged linguistic units* with a focus on heterogeneous data in terms of sample composition and entity type (e.g., content versus social).

Past research often preferred to gather a large corpus of text, compiled from many sources and typically sampled in regular intervals - the *US Election 2004/2008 Web Monitor* ([www.ecoresearch.net/election2008](http://www.ecoresearch.net/election2008)), for example, or the *Media Watch on Climate Change* ([www.ecoresearch.net/climate](http://www.ecoresearch.net/climate)). Using part-of-speech tagged and partially parsed corpora to identify relevant sketches (= co-occurrence lists for grammatical patterns provided by a grammar rule engine) improves the performance of existing techniques for computing semantic orientation [Kilgarriff et al. 2003, Kilgarriff et al. 2004], but processing arbitrarily long blocks of text still requires a fundamentally new strategy. The ability to maximize the algorithm's validity even when working with very short textual segments is paramount when trying to analyze the *evolution* of knowledge reflected in corpora. Longitudinal studies of specific topics or events often yield few additional occurrences of a term in a given interval, as incremental changes to existing documents are common. This complicates the analysis, since the validity of many text processing methods depends on corpus size and frequency of target terms.

### 3 Tagged Linguistic Units

Generic methods for computing semantic orientation, i.e. those that do not use machine learning algorithms on a narrowly defined domain, rely on a tagged dictionary that distinguishes between positive and negative sentiment words. The semantic orientation towards a target term is then calculated by measuring the distance (in words) between the target term and these sentiment words [Scharl et al. 2003].

Tagged dictionaries typically contain a few thousand words, annotated with positive or negative charges. They can be subjected to a reverse lemmatization procedure (word stemming), adding inflections to the initial list of sentiment words. But even assuming such an extended dictionary, dictionary-based approaches do not suffice for robust, scalable components to be embedded in corporate knowledge architectures.



This paper addresses this shortcoming by developing a hybrid method based on spreading activation networks coupled with machine learning algorithms for assigning sentiment charges to encountered linguistic units. For this purpose, the following linguistic units for computing the semantic orientation should be distinguished: *tokens* (single words), *terms* (multiple-word units of meaning), and *concepts* (units of meaning not tied to a particular lexical form and represented via rules or regular expressions).

A sentiment value and a context (for instance part-of-speech tag, geo location, or named entity) is assigned to each linguistic unit. The matrix of sentiment values is constantly being updated based on new data from the knowledge acquisition services, and can be customized for specific domains, applications or users. The outlined approach represents a significant improvement in terms of scalability and reliability. Generating and using a *Tagged Linguistic Unit (TLU)* database instead of a *tagged dictionary* that only contains words and binary classifications. This allows a fine-grained differentiation between the sentiment values associated with morphologically similar but semantically different linguistic units such as *cell*, *fuel cell* and *prison cell* and the consideration of tags like part-of-speech tags, named entity tags, and geo tags.

Work by Scharl et al. [Scharl et al. 2008] has demonstrated the usefulness of assigning sentiment values to geographic locations, but also shows how heavily these values depend on the text's context. Future approaches therefore will address these dependencies by combining tags with more sophisticated context information as for instance hierarchical classifications [Weichselbraun 2004] or topic tags. This approach is (i) *language-independent* in the sense that only a small set of seed terms (e.g., 100 positive and 100 negative words) and grammar patterns are required to initialize the machine learning algorithm and fine-tune the semantic values to any language that is decomposable into concepts, terms and tokens, (ii) not restricted to the categories of 'positive' and 'negative', but supporting an arbitrary number of linguistic categorizations such as weak  $\longleftrightarrow$  strong, passive  $\longleftrightarrow$  active, etc., (iii) ensures that *every* sentence or document can be annotated; traditional approaches often encounter sentences that do not contain any of the words listed in the tagged dictionary. Annotating the context unit (= sentence, paragraph or document) based on the *average sentiment vector* for all linguistic units encountered in the context unit, instead of only considering a few sentiment words.

Figure 1 illustrates sentiment scoring based on linguistic units. A tagging engine identifies part-of-speech tags, named entities, and geo locations facilitating the identification of linguist units by the phrase engine. The sentiment engine processes linguistic units and associated tags based on the data in the tagged linguistic units database, computing a sentiment value for the given text. Tagging provides important background information for these tasks - in the easiest case

the sentiment of linguistic units as for instance the word `like` depend on the assigned part-of-speech tag (`like/VB` versus `like/IN`), in more complex cases named entity tags or even geo tags might be necessary to correctly identify the TLU's sentiment value (e.g., in the case of `National Environment Trust`).

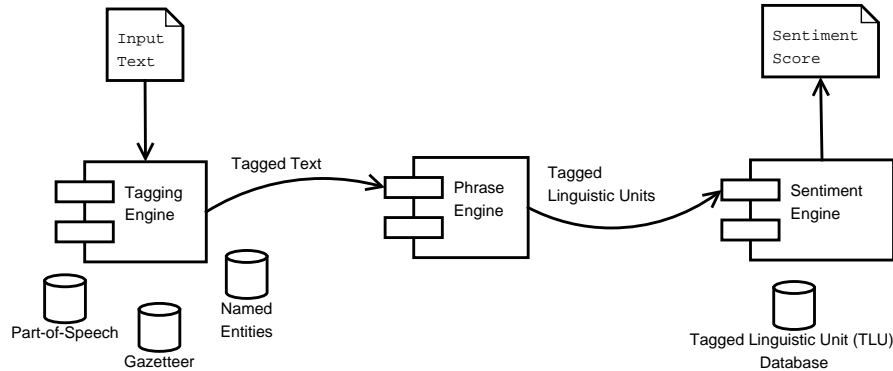

**Figure 1:** Sentiment Scoring based on Linguistic Units

#### 4 Iterative Extension and Optimization

As outlined in the previous section Tagged Linguistic Unit databases can be easily customized to specific domains and use cases. A domain specific corpus, language specific grammar rules and a set of seed terms with “known” sentiment values (as for instance provided by the conventional tagged dictionaries as the General Inquirer project) initialize the TLU database, the architecture identifies unknown linguistic units in the corpus and determines their sentiment value as illustrated in Figure 2.

The tagging component marks sentences with part-of-speech tags and identifies named entities such as people, organizations, and geographic locations. Combining co-occurrence analysis with a grammar rule engine yields candidate terms for extending the TLU database. Annotating these terms with named-entity tags and encoding characteristic grammatical patterns and known phrases creates a complex semantic network, which describes the relations between the identified linguistic units. Liu et al. [Liu et al. 2005] demonstrated how decomposing and translating semantic networks based on heuristic rules yields a spreading activation network facilitating the domain specific extension of domain ontologies.

Applying this approach for dynamically identifying and tracking tagged linguistic units builds a spreading activation network used to distribute the semantic charges between the units based on the features and annotations generated during the annotation step. Activation of concepts with known semantic charges in accordance to sign and strength of the charge leads to the propagation of energy pulses through the network, eventually distributing charges to all linguistic

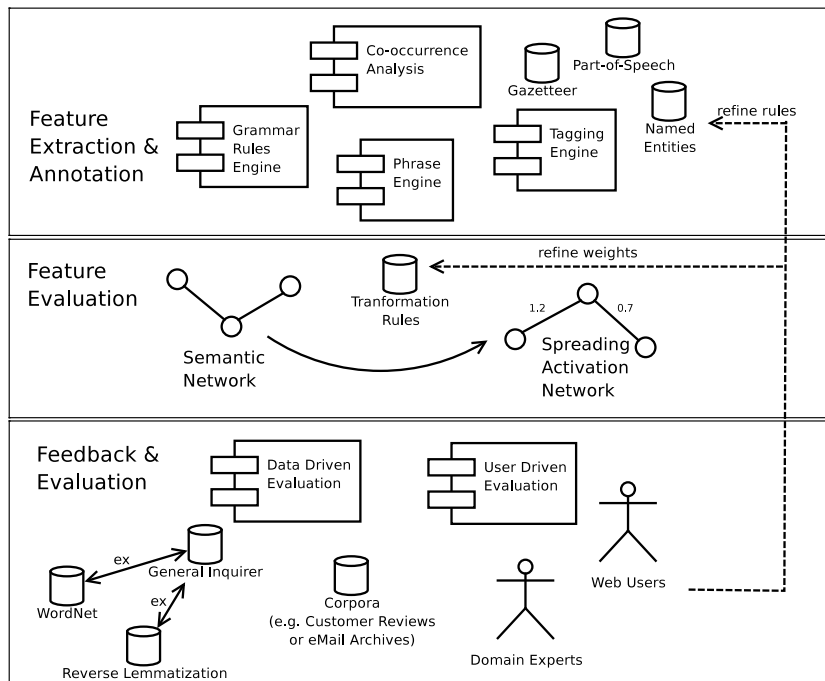

**Figure 2:** Iterative fine-tuning of the Tagged Linguistic Unit (TLU) Database

units. Analyzing the sentiment values' variance allows estimating confidence levels and facilitates the identifying of synonym  $\leftrightarrow$  antonym relationships.

Feedback gathered in the evaluation step adjusts and optimizes the transformation rules for the given domain and corpus, improving the quality of the TLU database with every subsequent step.

Automatic data-driven evaluation on a TLU level will help assess overall performance. Facilitating publicly available corpora like product (amazon.com), movie (www.imdb.com) and music reviews (www.metacritic.com, mp3.com) test cases for sentiment scoring will be developed and applied to the TLU database. Automated processes will be complemented by user-driven evaluations from domain experts and Web users. The feedback gathered by the data- and user-driven evaluations will be utilized to refine the transformation rules of the feature evaluation, and to identify candidate patterns for the inclusion into the databases of the grammar rule engine and the phrase engine.

Automatically generating TLU databases faces the problem of determining the correct charge (+0.4 vs. -0.4, for example) of the sentiment value to be assigned to the linguistics unit. The problem arises from the fact that synonyms and antonyms have very similar (co-)occurrence patterns in a given corpus. Advanced relation discovery techniques developed within the AVALON project

[Weichselbraun et al. 2007] will help overcome this challenge and facilitate the automation of this classification process. The machine learning algorithms can be trained and evaluated on augmented tagged dictionaries (created through reverse lemmatization and adding WordNet synonym and antonym pairs), as well as on publicly available tagged corpora that can serve as the ‘gold standard’.

## 5 Conclusion and Outlook

Simple approaches to sentiment detection based on co-occurrence patterns with terms from a tagged dictionaries scale well, but provide inferior results when comparing their output to complex methods that require a full parsing of sentence structures. The sheer volume of textual data, however, frequently rules out the most sophisticated approaches. Continuously updated databases of tagged linguistic units aim to balance accuracy and throughput. They represent a radical improvement over static sentiment scoring approaches based on tagged dictionaries, which still tend to be compiled manually.

Preliminary results from the described approach are promising. Following a formal evaluation of different approaches to sentiment detection, recall and precision were significantly improved by adding WordNet synonyms and antonyms to the tagged dictionary (only considering synsets with high frequencies to exclude rare and uncommon expressions) [Gindl and Liegl 2008]. Currently we are extracting terms from media corpora as candidates for assigning polarity values via co-occurrence analysis, which will further extend the tagged dictionary.

The increased effectiveness of sentiment detection algorithms will pave the way for a more widespread use in both academic and commercial applications. Refined versions of the sentiment detection method presented in this paper will generate a richer set of context information (e.g., ontology concepts or explicit references to other types of structured knowledge), and consider this information in the scoring process.

## Acknowledgment

The authors wish to thank Johannes Liegl for his feedback and suggestions. This work has been developed as part of RAVEN (Relation Analysis and Visualization for Evolving Networks) research project funded by the Austrian Ministry of Transport, Innovation & Technology (BMVIT) and the Austrian Research Promotion Agency (FFG) within the strategic objective FIT-IT ([www.fit-it.at](http://www.fit-it.at)).

## References

[Gindl and Liegl 2008] Gindl, S. and Liegl, J.: "Evaluation of Different Sentiment Detection Methods for Polarity Classification on Web-Based Reviews". In *Methods for*

- Polarity Classification on Web-Based Reviews. International Workshop on Computational Aspects of Affectual and Emotional Interaction, 18th European Conference on Artificial Intelligence. Patras, Greece. (2008).
- [Kilgarriff et al. 2003] Kilgarriff, A., Evans, R., Koeling, R., Rundell, M., and Tugwell, D.: "WASPBENCH: A Lexicographer's Workbench Supporting State-of-the-Art Word Sense Disambiguation". In 10th Conference on European Chapter of the Association For Computational Linguistics, Morristown, USA. Association for Computational Linguistics (2003).
- [Kilgarriff et al. 2004] Kilgarriff, A., Rychl, P., Smrz, P., and Tugwell, D.: "The Sketch Engine". In 11th Euralex international Congress, Lorient, France (2004).
- [Kushal et al. 2003] Kushal, D., Lawrence, S., and Pennock, D. M.: "Mining the Peanut Gallery: Opinion Extraction and Semantic Classification of Product Reviews". In WWW '03: Proceedings of the twelfth international conference on World Wide Web. ACM Press, (2003), 519–528.
- [Liu et al. 2005] Liu, W., Weichselbraun, A., Scharl, A., and Chang, E.: "Semi-Automatic Ontology Extension Using Spreading Activation", *Journal of Universal Knowledge Management*, 0, 1 (2005), 50–58.
- [Mullen and Collier 2004] Mullen, T. and Collier, N.: "Sentiment Analysis Using Support Vector Machines with Diverse Information Sources" (2004).
- [Pang and Lee 2004] Pang, B. and Lee, L.: "A Sentimental Education: Sentiment Analysis Using Subjectivity Summarization Based on Minimum Cuts". In Proceedings of the 42nd ACL, (2004), 271–274.
- [Pang et al. 2002] Pang, B., Lee, L., and Vaithyanathan, S.: "Thumbs up? Sentiment Classification using Machine Learning Techniques". In Proceedings of the 2002 Conference on Empirical Methods in Natural Language Processing (EMNLP) (2002).
- [Scharl et al. 2008] Scharl, A., Dickinger, A., and Weichselbraun, A.: "Analyzing News Media Coverage to Acquire and Structure Tourism Knowledge", *Information Technology and Tourism*, 10, 1 (2008), 3–17.
- [Scharl et al. 2003] Scharl, A., Pollach, I., and Bauer, C.: "Determining the Semantic Orientation of Web-based Corpora". In Liu, J., Cheung, Y., and Yin, H., editors, *Intelligent Data Engineering and Automated Learning, 4th International Conference, IDEAL-2003, Hong Kong (Lecture Notes in Computer Science, Vol. 2690)*, Berlin. Springer, (2003), 840–849.
- [Scharl and Weichselbraun 2006] Scharl, A. and Weichselbraun, A.: "Web Coverage of the 2004 US Presidential Election". In 11th Conference of the European Chapter of the Association for Computational Linguistics (EACL-2006), Trento, Italy. Association for Computational Linguistics, (2006), 35–42.
- [Subasic and Huettner 2001] Subasic, P. and Huettner, A.: "Affect Analysis of Text Using Fuzzy Semantic Typing", *IEEE Transaction on Fuzzy Systems*, 9, 4 (2001), 483–496.
- [Weichselbraun 2004] Weichselbraun, A.: "Ontologiebasierende Textklassifikation mittels mathematischer Verfahren". PhD thesis, Vienna University of Economics and Business Administration (2004).
- [Weichselbraun et al. 2007] Weichselbraun, A., Wohlgenannt, G., Scharl, A., Granitzer, M., Neidhart, T., and Juffinger, A.: "Applying Vector Space Models to Ontology Link Type Suggestion". In 4th International Conference on Innovations in Information Technology, Dubai, United Arab Emirates. IEEE Press, (2007), 566–570.
- [Whitelaw et al. 2005] Whitelaw, C., Garg, N., and Argamon, S.: "Using Appraisal Taxonomies for Sentiment Analysis". In Proceedings of MCLC-05, the 2nd Midwest Computational Linguistic Colloquium, Columbus, US (2005).
- [Wilson et al. 2005] Wilson, T., Wiebe, J., and Hoffmann, P.: "Recognizing Contextual Polarity in Phrase-Level Sentiment Analysis". In Proceedings of Human Language Technologies Conference/Conference on Empirical Methods in Natural Language Processing (HLT/EMNLP 2005), Vancouver, CA (2005).

## Using Domain Knowledge Provided by Ontologies for Improving Data Quality Management

**Stefan Brueggemann**

(OFFIS, Oldenburg, Germany  
brueggemann@offis.de)

**Fabian Gruening**

(University of Oldenburg, Germany  
fabian.gruening@informatik.uni-oldenburg.de)

**Abstract:** Several data quality management (DQM) tasks like duplicate detection or consistency checking depend on domain specific knowledge. Many DQM approaches have potential for bringing together domain knowledge and DQM metadata. We provide an approach which uses this knowledge modeled in ontologies instead of acquiring that knowledge by cost-intensive interviews with domain-experts. These ontologies can directly be annotated with DQM specific metadata. With our approach a synergy effect can be achieved when modeling a domain ontology, e.g. for defining a shared vocabulary for improved interoperability, and performing DQM. We present three DQM applications which directly use knowledge provided by domain ontologies. These applications use the ontology structure itself to provide correction suggestions for invalid data, identify duplicates, and to store data quality annotations at schema and instance level.

**Key Words:** Data Quality Management, Domain Ontologies, Knowledge Representation, Metadata Annotation

**Category:** H.2.8, I.2.4, M.4

### 1 Motivation and goal

Data Quality Management (DQM) approaches report on the quality of data measured by defined data quality dimensions and, if desired, correct data in databases. DQM relies on domain knowledge for detecting and possibly correcting erroneous data, as data without its definition cannot be interpreted as information and is therefore meaningless. On the one hand, DQM approaches like [Hinrichs 2002] or [Amicis and Batini(2004)] define phases where domain experts provide their knowledge for further utilization in the DQM process. On the other hand, there are domain ontologies, i.e. formal specifications of conceptualizations of certain domains of interest, that already provide such knowledge but remain unused in the DQM context. Our contribution is to directly use the knowledge provided by domain ontologies in the DQM context in order to improve the DQM's outcome.

This paper is structured as follows: Firstly, we will discuss work related to this topic and secondly describe our approach which directly uses the knowledge

provided by domain ontologies in the context of DQM in detail by presenting three applications, namely consistency checking, duplicate detection, and meta-data management. Finally, we will draw some conclusions and point out further work that results from this work.

## 2 Related Work

Little work has been done on the field of using ontologies for DQM. Existing approaches can be divided into two major classes:

The first application of ontologies in the case of DQM is management of data quality problems and methods. The OntoClean Framework has been introduced in [Wang et al. 2005]. It provides a template for performing data cleaning consisting of several steps like building an ontology, translating user goals for data cleaning into the ontology query language, and selecting data cleaning algorithms.

The second application of ontologies is the use of domain ontologies. They provide domain specific knowledge needed to validate and clean data. This allows for detecting data problems, which could not be found without this knowledge. To the best of our knowledge, only [Milano et al. 2005] and [Kedad and Métais 2002] use domain ontologies in this way.

We extend these approaches by annotating domain ontologies with DQM-specific metadata which we show in the following section by presenting three DQM-applications that further include the usage of algorithms of the data mining domain.

## 3 Multiple utilizations of domain ontologies for DQM

To show the advantages of using ontologies in the context of DQM and emphasize the usefulness of our approach to improve the outcome of DQM we present three applications of domain ontologies in that context: consistency checking, duplicate detection, and metadata management.

### 3.1 Context-sensitive inconsistency-detection with ontologies

Data cleaning is often performed when data have to be integrated into a database. Data cleaning consists of the detection and removal of errors and inconsistencies from data [Rahm and Do 2000]. We use domain specific knowledge to detect inconsistencies. Consistency is defined as the abidance of semantic rules. These rules can be described with integrity constraints in relational databases for attributes on schema level. On instance level, consistency is being defined as the correct combination of attribute values. A tuple is consistent when the values from each attribute are valid in combination.

We now provide an algorithm and a data model for consistency checking.

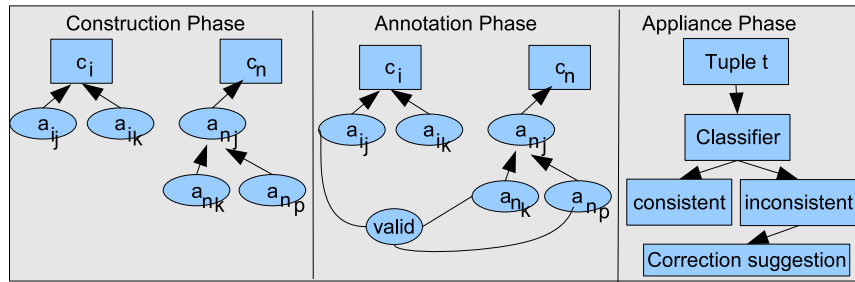

Figure 1: Overview of an inconsistency detection algorithm using a domain ontology

### 3.1.1 Basic Idea

Figure 1 shows a graphical representation of the consistency checking algorithm. The algorithm consists of three phases. In the construction phase a domain ontology is being created. It can be learned from an existing database, created manually, or already existing ontologies can be used. The expressive power of OWL (web ontology language) enables a generic semi-automatic ontology construction approach. The domain ontology can mostly be directly used for DQM, just tuples have to be labeled as valid in the annotation phase. In the appliance phase tuples are being identified as being consistent or inconsistent. When an inconsistency is being detected, a correction suggestion is made. The ontology structure is used to correct invalid tuples. Other valid tuples are searched and characterized as possible corrections. The suggestions are ranked using the distance between the valid and invalid tuples. The advantage over the statistical edit/imputation-approach presented by [Fellegi and Holt 1976] is the usage of the context of invalid attributes for correction. The statistical approach replaces invalid tuples with randomly chosen values, whilst our approach suggests context-sensitive corrections changing as few attributes as possible.

### 3.1.2 Data model used for consistency checking

A relation schema  $R = (A_1, \dots, A_n)$  is defined as a list of attributes  $A_1, \dots, A_n$ . Each attribute  $A_i$  belongs to a domain  $dom(A_i)$ . Each domain  $dom(A_i)$  defines a non-empty set of valid values. A relation  $r$  of  $R$  is a set of  $n$ -tuples  $r = t_1, \dots, t_m$ . Each tuple  $t_i$  is a set of values  $t_i = (v_{i_1}, \dots, v_{i_n})$  with  $v_{i_j} \in dom(A_j)$ .

In the simplest case a tuple  $t_i$  is valid iff  $\forall 1 \leq j \leq n : v_{i_j} \in dom(A_j)$ . According to our definition, a tuple is consistent if it is valid and all  $v_{i_j}$  are combined correctly.



When validating a tuple  $t$ , using only the domains  $dom(A_j)$  doesn't enable to identify inconsistencies because combinations cannot be checked. Therefore an ontology is being built containing all values  $a_{i_k} \in dom(A_i)$  of each domain with  $k = |dom(A_i)|$ . Furthermore, domains often contain hierarchical, multidimensional, or other complex structures. These can be respected in an ontological structure.

An ontology consists of a concept  $C_i$  for each domain  $dom(A_i)$ . Attributes  $a_i$  are defined as individuals of  $C_i$ . They are arranged using "moreSpecificThan" properties to enable modeling complex structures.

Dependencies are defined between concepts. For instance, there is often no semantic dependency between the attributes "id" and "surname". Instead, in oncology, several constraints exist when combining "localization"-values and "T", "N", and "M"-values from the TNM-classification (tumour, node, metastasis) scheme [UICC 2001]. Concepts have properties "valid" and "invalid" to combine attributes of different concepts and to label them as valid or invalid.

### 3.1.3 Example

We now provide an example from tumour classification in the cancer registry of lower saxony. Figure 2 shows an ontology containing the concept Localization, which depends on the concept T. The individuals "C02", "C02.1", "C02.2", and "C02.3" describe malignant neoplasms of the tongue, where the "C02.x" (tip, bottom, 2/3 of front) individuals are more specific than "C02". The property "moreSpecificThan" is hidden due to readability. The three "valid" nodes are introduced as blank nodes and used to describe the following three consistency rules: "C02.1" is only valid with "T"-values "1a" and "1b". "T"-values lower than 2 describe tumour-sizes lower than 2cm. "C02.2" is valid with "T"-Values "1a", "1b", "2a", and "2b". "2x"-values are sizes between 2 and 5cm. "T"-values larger than "2" describe tumour sizes larger than 5cm. "C02.3" is valid with "T"-values "1", "2", and "3". Specifying these connections with "i" defines these as inheriting connections. These connections are inherited to the children of "1", "2", and "3". Therefore the more specific values of "1", "2", and "3", namely "1a", "1b", "2a", "2b", "3a", and "3b", are also valid with "C02.3".

For instance, the tuple  $\langle C02.3, 1 \rangle$ ,  $\langle C02.3, 3 \rangle$ , and  $\langle C02.1, 1a \rangle$  with the structure  $\langle Localization, T \rangle$  can be resolved as valid. The tuple  $\langle C02.1, 3 \rangle$  instead can be identified as invalid, but using the ontological structure, the tuple  $\langle C02.1, 1a \rangle$ ,  $\langle C02.1, 1b \rangle$ ,  $\langle C02.3, 3 \rangle$ ,  $\langle C02.1, 3a \rangle$ , and  $\langle C02.1, 3b \rangle$  can be resolved as correction suggestions.

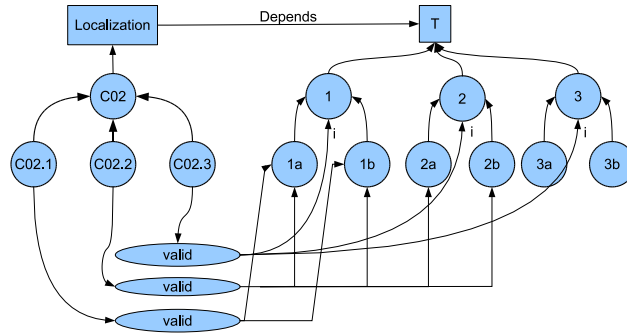

**Figure 2:** Ontology containing concepts Localization and T with individuals

### 3.2 Duplicate Detection

[Schünemann 2007] presents an algorithm and its evaluation for several configuration based on [Bilenko and Mooney(2003)] for detecting duplicates in databases which are multiple representations of one real world entity and therefore a major issue relevant e.g. in the scenario of integrating several databases. Figure 3 shows a graphical representation of the algorithm which uses a classification algorithm from the data mining domain and will be explained in the following.

The algorithm consists of two consecutive phases, the learning phase and the application phase. In the learning phase a classifier learns the characteristics of duplicates from labeled data, i.e. pairs of instances that are marked as duplicates or non-duplicates. The algorithm's inputs are the distances between every two of the instances' attributes and the information whether or not the instances are duplicates. The algorithm's output is a classifier that is able to distinguish between duplicates and non-duplicates by having identified the combination and grade of those attributes' similarities, that are relevant for instances being duplicates. The application phase uses those classifiers for detecting duplicates in non-labeled data. The advantage over the statistical approach presented by [Fellegi and Sunter 1969] is the usage of similarity metrics, e.g. string distance metrics, to calculate the attributes' distances instead of using binary information whether two attributes have identical values or not as those metrics are more sensitive in case of small differences.

Although the described algorithm can be used to find duplicates in any database using any data model the usage of ontology provides a major advantage: As ontologies' concepts represent real world extracts without any normalization or considerations with respect to the performance of the database e.g. by artificially inserting redundancy those concepts' attributes describe a real world entity completely. Such an algorithm can therefore directly be applied to the concepts' instances as they semantically contain all information that it is defined

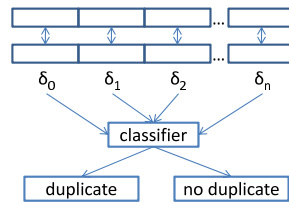

Figure 3: A duplicate detection algorithm using a classification algorithm. In the learning phase, the algorithm’s inputs are the distances between the correspondent attributes and the knowledge about whether or not the instances are duplicates, in the application phase that knowledge is deduced through the classifier that is the learning phase’s output.

by. There is not the "object identification problem" where real world entities are scattered around several data model elements, e.g. tables, or extended by artificial values like (primary) keys that are not relevant to the decision whether or not two instances represent the same real world entity. Therefore ontologies’ conceptualizations provide an ideal basis for duplicates detection in databases. Furthermore the labels that show which instances are correct and therefore are used to learn from, the scales of measurement of the attributes for calculating meaningful distances etc. are user-defined metadata that is annotated through the ontology as well.

### 3.3 Metadata Annotation

Models for data quality are used to make statements about data regarding to their data quality. [Batini and Scannapieco 2006] point out that those models are a major issue for establishing a DQM approach. We show three DQM-specific metadata tasks where ontologies and especially their serializations in RDF (resource description framework) are an excellent choice for making those statements that seamlessly integrate into existing databases.

#### 3.3.1 Data Provenance

Establishing a DQM approach oftentimes requires an integration of several data sources. Data provenance refers to the task of keeping track of the data’s origins for correctly giving information about the data quality’s state of those databases. XML Namespaces that are widely used to identify RDF’s resources’ origins can directly be used to point out the database the data is coming from.

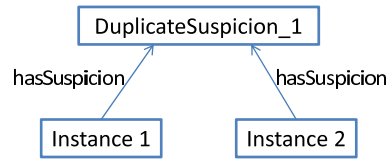

**Figure 4:** Annotation of a duplicate suspicion.

### 3.3.2 Data Quality Annotations at Schema and Instance Level

Both on schema and instance level annotations are needed for DQM. On schema level DQM-algorithms might need to know the attributes' levels of measurements for proper preprocessing. At instance level several annotations like labeling for consistency checking (refer to section 3.1), duplicate detection (see section 3.2), or rule mining (refer to [Brüggemann 2008]) can be performed.

Again, RDF's resources provide an elegant way to make statements about data on both schema and instance level, as also RDF-Schema and OWL-Ontologies are usually serialized as RDF-triples. Those resources can be used as subject in statements about data quality aspects, e.g. that a number is a nominal value (e.g. an identifier for a room) and therefore distances of two of those values cannot be calculated meaningfully. The duplicate detection algorithm must handle such an information e.g. by applying "1" to the distance if those values are different and "0" otherwise.

### 3.3.3 An Ontology for the DQM-domain

The annotations introduced in the preceding section need a vocabulary. Such a vocabulary can be provided by creating a DQM-Ontology. Such an ontology has to cover concepts for the following annotations: On schema level the level of measurements have to be annotated for proper preprocessing. On instance level the preprocessed values as well as time stamps for measuring the values currencies have to be annotated. Furthermore, the already mentioned labeling of consistent tuples and labels for training data mining algorithms have to be annotated. Erroneous data has to be pointed out, specifying the reason for the suspected error like outliers, inconsistencies (also see [Uslar and Grüning 2007]) or duplicates, as shown in figure 4. Therefor an instance of the concept "DuplicateSuspicion" is generated and both instances get connected to the instance via the property "hasSuspicion".

## 4 Conclusions and Future Work

The usage of the knowledge provided by domain ontologies can be used to improve DQM's outcomes in several ways as shown by three given examples, namely

consistency checking, duplicate detection, and the seamless possibility of meta-data annotation. Therefore, a synergy effect from modeling a domain ontology, e.g. for defining a shared vocabulary for improved interoperability, and DQM can be achieved. The further work will include the appliance of our described approaches on enterprise scaled databases to verify their applicability. The EWE AG (please visit [www.ewe.de](http://www.ewe.de)) partly funds the projects the presented results originate from and also provide such data for large scale tests. As described, another test szenario is tumour classification in cancer registries.

## References

- [Amicis and Batini(2004)] Amicis, F.D., Batini, C.: "A methodology for data quality assessment on financial data." *Studies in Communication Sciences*, 4:115–136, 2004.
- [Batini and Scannapieco 2006] Batini, C., Scannapieco, M.: "Data Quality" Springer, Berlin / Heidelberg 2006.
- [Bilenko and Mooney(2003)] Bilenko, M., Mooney, J.R.: Employing trainable string metrics for information integration. In *Proceedings of the IJCAI-2003 Workshop on Information Integration on the Web*, pages 67–72, Acapulco, Mexico, 8 2003.
- [Brüggemann 2008] Brüggemann, S.: "Rule mining for automatic ontology based data cleaning". In *Proc. APWeb 2008*, 2008.
- [Fellegi and Holt 1976] Fellegi, I.P., Holt, D.: "A systematic approach to automatic edit and imputation." *Journal of the American Statistical Association*, 71:17–35, 1976.
- [Fellegi and Sunter 1969] Fellegi I.P., Sunter, A.B.: A theory for record linkage. *Journal of the American Statistical Association*, 64(328):1183–1210, 1969.
- [Hinrichs 2002] Hinrichs, H.: "*Datenqualitätsmanagement in Data Warehouse-Systemen*". PhD thesis, Universität Oldenburg, 2002.
- [UICC 2001] International Union Against Cancer (UICC) 2001. "*TNM Classification of Malignant Tumours, 6th edition*". John Wiley & Sons, Hoboken, New Jersey (2001).
- [Kedad and Métais 2002] Kedad, Z., Métais, E.: "Ontology-based data cleaning". NLDB (2002).
- [Milano et al. 2005] Milano, D., Scannapieco, M., Catarci, T.: "Using ontologies for xml data cleaning". In P. H. Robert Meersman, Zahir Tari, editor, *On the Move to Meaningful Internet Systems 2005*, volume 3762. LNCS, Springer Berlin / Heidelberg, 2005.
- [Rahm and Do 2000] Rahm, E., Do, H.H.: "Data cleaning: Problems and current approaches". *Bulletin of the IEEE Computer Society Technical Committee on Data Engineering*, 23(4):3–13, 2000.
- [Schünemann 2007] Schünemann, M.: Duplikatenerkennung in Datensätzen mithilfe selbstlernender Algorithmen. Master thesis, Universität Oldenburg, 2007.
- [Uslar and Grüning 2007] Uslar, M., Grüning, F.: Zur semantischen Interoperabilität in der Energiebranche: CIM IEC 61970. *Wirtschaftsinformatik*, 49(4):295–303, 9 2007.
- [Wang et al. 2005] Wang, X., Hamilton, H. J., Bither, Y.: "An ontology-based approach to data cleaning". Technical report, Department of Computer Science, University of Regina, June 2005.

## A Knowledge-based Solution for Core Competence Evaluation in Human-Capital Intensive Companies

Simona Colucci  
(Politecnico di Bari, Bari, Italy and  
D.O.O.M. s.r.l., Matera, Italy  
s.colucci@poliba.it)

Eugenio Di Sciascio  
(Politecnico di Bari, Bari, Italy,  
disciascio@poliba.it)

Francesco M. Donini  
(Università della Tuscia, Viterbo, Italy,  
donini@unitus.it)

**Abstract:** Determining fields of excellence in the know-how of knowledge intensive companies is often a crucial decisional process, aimed e.g., at identifying the competence to be strengthened or to invest on in a long term strategy. In this paper we propose a semantic-based approach for automatic extraction of such a specializing knowledge, usually called Core Competence in knowledge management literature. The proposed approach exploits Description Logics as formalism for the representation of knowledge sources and implements novel reasoning services, in particular *informative common subsumers* specifically devised for Core Competence evaluation.

**Key Words:** Common Subsumers, Core Competence, Description Logics.

**Category:** M.4, M.7, H.3.3

### 1 Introduction

Since first investigations on the role of knowledge in human-capital intensive companies, the capability to focus on a significant portion of the organizational know-how has been identified as a crucial asset for business success. Such a belief is at the basis of the so-called *Resource-based Theory* of the firm [Wernerfelt, 1995], according to which unique company capabilities should be exploited to achieve competitive advantage [Barney, 1991, L. Halawi and McCarthy, 2005, Meso and Smith, 2000]. In particular, the term Core Competence was introduced [Hamel and Prahalad, 1990] to denote such a specializing portion of organizational know-how. It is intuitive that the hardness of identifying such an intellectual capital increases with the size of the company and with the ambiguity of company know-how descriptions.

In recent years we have been investigating knowledge-based approaches and solutions for a specific field of knowledge management, namely skills and competence management, in the framework of Description Logics (DLs)[Baader et al., 2002] and

semantic technologies, both exploiting classical inference services and introducing new ones [Colucci et al., 2007b]. As it is nowadays well-known, semantic-based technologies ask for company intellectual capital to be unambiguously described in formal representations, according to a shared vocabulary provided by ontologies modeling skills domain. In particular, our solutions employ DLs for knowledge representation and exploit DL reasoning services to infer new knowledge on the elicited descriptions. Obviously, once company know-how has been formally represented in a common knowledge base in terms of individual profile descriptions and know-how, such a repository could be exploited to extract the most characterizing portion of company intellectual capital, *i.e.* company Core Competence. Nevertheless this is easier said than done, as well-known reasoning services fail to provide such information. As we show later on, the apparently best suited inference service for the above task, the *Least Common Subsumer* [Cohen et al., 1992], shows clear limits.

In this paper we therefore propose new non-standard inference services on collections of individual profile descriptions formalized in DL, for the automatic extraction of company Core Competence. Such specifically developed reasoning services are introduced in Section 2. Two different Core Competence evaluation approaches are then detailed in Section 3, before closing the paper with conclusions.

## 2 New Services Definition

In the automated Core Competence extraction we propose, we refer to  $\mathcal{ALN}$  (Attributive Language with Number Restrictions) for formally describing knowledge sources of a company.  $\mathcal{ALN}$  provides a limited set of constructs, which allow for describing the knowledge domain by combining the basic elements of a DL, namely **concept names**, representing objects of the domain — *i.e.* *ProductionManagement*, *AssetAllocation*, *Creativeness* and *AssetManager* — and **role names**, representing possible binary relationships among concepts, *i.e.* *knows*, *isAbleTo*. Every DL includes two concepts,  $\top$  and  $\perp$ , representing a concept interpreted by the whole domain and by an empty set, respectively.  $\mathcal{ALN}$  allows also for **qualified universal restrictions** — *i.e.*  $\forall \textit{knows.AssetAllocation}$  denotes an advanced knowledge in Asset Allocation — and **number restrictions** — *i.e.*  $(\geq 3 \textit{knows})$ ,  $(\leq 2 \textit{isAbleTo})$  denote the possession of at least three skills and at most two abilities — over roles. By using such constructs it is possible to detail concept **inclusions** and **definitions**, which constitute the intensional knowledge of a DL system, what is called a **TBox** in DL and **ontology** in knowledge representation. For example the inclusion  $\textit{AssetManager} \sqsubseteq \textit{Manager}$  asserts that the set of asset managers in the domain is included in the one of managers; the concept definition  $\textit{AssetManager} \equiv \textit{Manager} \sqcap \forall \textit{knows.AssetAllocation}$  gives instead to managers endowed with Asset Allocation knowledge the name of Asset Manager, like the definition  $\textit{Manager} \equiv \sqcap \forall \textit{knows.Management}$  gives the name manager to subsets of domain possessing Management knowledge.

Every DL allows for basic reasoning services inferring new knowledge from the descriptions elicited in the TBox; in particular *satisfiability* and *subsumption* are defined for every DL. In a nutshell, satisfiability checks for internal coherency of concept descriptions, evaluating the consistency of elicited information; subsumption checks instead whether a concept description is more generic than another one. Formally, subsumption is defined as follows, with respect to a domain interpretation function  $\mathcal{I}$ :

**Definition 1 (Subsumption)** Given two concept descriptions  $C$  and  $D$  and a TBox  $\mathcal{T}$  in a DL  $\mathcal{L}$ , we say that  $D$  subsumes  $C$  w.r.t.  $\mathcal{T}$  if for every model of  $\mathcal{T}$ ,  $C^{\mathcal{I}} \subset D^{\mathcal{I}}$ . We write  $C \sqsubseteq_{\mathcal{T}} D$ , or simply  $C \sqsubseteq D$  if we assume an empty TBox.

Having a collection of concept descriptions in a DL  $\mathcal{L}$ , the problem of determining the Least Common Subsumer(LCS) of the collection has been proposed by Cohen, Borgida and Hirsh [Cohen et al., 1992] as a non-standard reasoning service. By definition, the LCS of a collection of concept descriptions represents the most specific concept description subsuming all of the elements of the collection. Formally, we recall the following definition:

**Definition 2 (LCS,[Cohen and Hirsh, 1994])** Let  $C_1, \dots, C_n$  be  $n$  concepts in a DL  $\mathcal{L}$ . An  $LCS(C_1, \dots, C_n)$ , is a concept  $E$  in  $\mathcal{L}$  such that the following conditions hold:  
 (i)  $C_i \sqsubseteq E$  for  $i = 1, \dots, n$   
 (ii)  $E$  is the least  $\mathcal{L}$ -concept satisfying (i), i.e., if  $E'$  is an  $\mathcal{L}$ -concept satisfying  $C_i \sqsubseteq E'$  for all  $i = 1, \dots, n$ , then  $E \sqsubseteq E'$

If the collection contains employee profile descriptions, as in our reference scenario, the LCS represents the competence shared by all the employees in the collection. Such a concept description is a good candidate for determining the Core Competence of the company at a first sight. Nevertheless the need for the LCS to subsume each concept in the collection causes its corresponding description to be too generic in most cases: if a competence has to be shared by the whole company personnel it needs to be quite generic. As a toy example, consider a small company in which only the following three employees work:

- Nick:  $AssetManager \sqcap \forall isAbleTo.Creativeness$
- Frank:  $\forall knows.AssetAllocation \sqcap \forall isAbleTo.Creativeness$
- Robert:  $Engineer \sqcap \forall isAbleTo.Creativeness$

The only LCS of such a collection is Creativeness ability, which might result a not much significant knowledge. If we instead give up such a full skill coverage and accept the assumption that Core Competence needs to be possessed by a significant portion of company personnel, more interesting results can be achieved. Obviously the required degree of coverage may be set by company management. To this aim, we propose and introduce new reasoning services.

**Definition 3 (k-CS)** Let  $C_1, \dots, C_n$  be  $n$  concepts in a DL  $\mathcal{L}$ , and let be  $k < n$ . A  $k$ -Common Subsumer ( $k$ -CS) of  $C_1, \dots, C_n$  is a concept  $D$  such that  $D$  is an LCS of  $k$  concepts among  $C_1, \dots, C_n$ .

If the example company management decides that 2/3 of the employees have to



possess some knowledge to consider it part of the Core Competence, Asset Allocation knowledge represents a commonality between two employees (according to the definitions at the beginning of the section) and then a Core Competence. Of course also Creativeness ability is a  $k$ -CS of the collection, but it does not add any informative content to the LCS: for this reason we distinguish in the following  $k$ -Common Subsumers adding informative content to LCS.

**Definition 4 (IkCS)** Let  $C_1, \dots, C_n$  be  $n$  concepts in a DL  $\mathcal{L}$ , and let  $k < n$ . An *Informative  $k$ -Common Subsumer (IkCS)* of  $C_1, \dots, C_n$  is a  $k$ -CS  $E$  such that  $E$  is strictly subsumed by  $LCS(C_1, \dots, C_n)$ .

Among possible *IkCSs*, some are characterized by maximal cardinality of the set of subsumed concepts: in our example scenario, if we set  $k = 3$  Asset Allocation knowledge stops being a  $k$ -CS and the only common subsumer is Creativeness ability, which is not informative by definition. We define in the following concepts like Asset Allocation as best informative common subsumers (with  $k = 2$ ).

**Definition 5 (BICS)** Let  $C_1, \dots, C_n$  be  $n$  concepts in a DL  $\mathcal{L}$ . A *Best Informative Common Subsumer (BICS)* of  $C_1, \dots, C_n$  is a concept  $B$  such that  $B$  is an Informative  $k$ -CS for  $C_1, \dots, C_n$ , and for every  $k < j \leq n$  every  $j$ -CS is not informative.

For collections whose LCS is equivalent to the universal concept  $\top$ , the following definition makes also sense:

**Definition 6 (BCS)** Let  $C_1, \dots, C_n$  be  $n$  concepts in a DL  $\mathcal{L}$ . A *Best Common Subsumer (BCS)* of  $C_1, \dots, C_n$  is a concept  $S$  such that  $S$  is a  $k$ -CS for  $C_1, \dots, C_n$ , and for every  $k < j \leq n$  every  $j$ -CS  $\equiv \top$ .

Consider for example a new employee :

– *Fred = Manager  $\sqcap \forall$ knows.ProductionManagement.*

The only LCS of the collection including the four employees is the universal concept. On the contrary, for  $k = 3$  we have Creativeness ability as  $k$ -common subsumer, which is informative w.r.t. the LCS (it is equivalent to the universal concept) and best: if we add one unit to  $k$  the  $k$ -CS reverts to the universal concept.

### 3 Solutions to Core Competence Evaluation Problem

In this paper we provide two processes for Core Competence evaluation: the first one exploits the services introduced in Section 2 to discover unknown fields of excellence of the company; the second one checks for the possession of a list of known target competencies by a significant portion of company personnel and explains how to reach the target in case the check fails.

Both of the approaches ask for the concepts to be written in *Concept Components* according to the following rules. If  $C$  is a concept description in a DL  $\mathcal{L}$ , with  $C$  written in a conjunction  $C^1 \sqcap \dots \sqcap C^m$ , the *Concept Components* of  $C$  are defined as follows: if  $C^j$ , with  $j = 1 \dots, m$  is either a concept name or a negated concept name or a number restriction, then  $C^j$  is a *Concept Component* of  $C$ ; if  $C^j = \forall R.E$ , with  $j = 1 \dots, m$ ,

then  $\forall R.E^k$  is a *Concept Component* of  $C$ , for each  $E^k$  concept component of  $E$ . The definition of *Subsumers Matrix* in the following is preliminary to both processes of Core Competence evaluation.

**Definition 7 (Subsumers Matrix)** Let  $C_1, \dots, C_n$  be a collection of concept descriptions  $C_i$  in a Description Logic  $\mathcal{L}$  and let  $D_j \in \{D_1, \dots, D_m\}$  be the *Concept Components* deriving from a set of concepts. We define the **Subsumers Matrix**  $S = (s_{ij})$ , with  $i = 1 \dots n$  and  $j = 1 \dots m$ , such that  $s_{ij} = 1$  if the component  $D_j$  subsumes  $C_i$ , and  $s_{ij} = 0$  if the component  $D_j$  does not subsume  $C_i$ .

Referring to Subsumers Matrix, we define:

**Concept Component Signature** ( $sig_{D_j}$ ): set of indexes of concepts  $C_1, \dots, C_n$  subsumed by  $D_j$ ; observe that  $sig_{D_j} \subseteq \{1, \dots, n\}$ ;

**Concept Component Cardinality** ( $T_{D_j}$ ): cardinality of  $sig_{D_j}$ , that is, how many concepts among  $C_1, \dots, C_n$  are subsumed by  $D_j$ . Such a number is  $\sum_{i=1}^n s_{ij}$ ;

**Maximum Concept Component Cardinality** ( $M_S$ ): maximum among all concept component cardinalities, that is,  $M_S = max\{T_{D_1}, \dots, T_{D_m}\}$ ;

**Second Maximum Concept Component Cardinality** ( $PM_S$ ): maximum among the cardinalities of concept components not subsuming all  $n$  concepts in the collection ( $PM_S = max\{T_{D_j} | T_{D_j} < n\}$ ); by definition  $PM_S < n$ ;

**Common Signature Class** ( $\cap_{sig_{D_j}}$ ): concept formed by the conjunction of all concept components whose signature contains  $D_j$ :  $\cap\{D_h | sig_{D_j} \subseteq sig_{D_h}\}$

### 3.1 Core Competence Extraction

**Definition 8 (Collection Subsumers Matrix)** Let  $C_1, \dots, C_n$  be a collection of concept descriptions  $C_i$  in a Description Logic  $\mathcal{L}$ . We define the **Collection Subsumers Matrix** as a Subsumers Matrix in which  $D_j \in \{D_1, \dots, D_m\}$  are the concept components deriving from all concepts in the collection.

In the following we define, with respect to a collection of concept descriptions,  $\underline{BCS}$  the set of BCSs,  $\underline{BICS}$  the set of BICSs,  $\underline{ICS}_k$  the set of ICSs, given  $k < n$  and  $\underline{CS}_k$  the set of k-CSs, given  $k < n$ . In [Colucci et al., 2008] we proposed Algorithm 1 determining the sets  $\underline{BICS}$ ,  $\underline{CS}_k$ ,  $\underline{ICS}_k$ ,  $\underline{BCS}$  of a collection  $\{C_1, \dots, C_n\}$  of concepts in  $\mathcal{ALN}$ , whose Subsumers Matrix is given as input. In order to understand the rationale of the proposed algorithm, consider the company with the four employees (Nick, Frank, Robert and Fred) in the tiny example in Section 2. The concept components coming from the collection of employees are:  $D_1 = \forall knows.Management$ ,  $D_2 = \forall knows.AssetAllocation$ ,  $D_3 = \forall isAbleTo.Creativeness$ ,  $D_4 = Engineer$ ,  $D_5 = \forall knows.ProductionManagement$ . The collection subsumers matrix is shown in the left-hand side of Figure 1. If  $k = 2$ , the only components with cardinality at least equal to  $k$  are  $D_1$ ,  $D_2$  and  $D_3$  and then their common class signature is added to the set  $\underline{CS}_k$  (line 3), which contains the  $k - CS$ s  $D_1, D_2 \sqcap D_3$  and  $D_3$ . The check in line 4 results true for all of the three components, given that the only concept subsuming the four employee profiles is the universal concept; the three concepts in  $\underline{CS}_k$  are then added to

**Input** : Collection Subsumers Matrix  $S = (s_{ij})$  for a collection of concepts  $\{C_1, \dots, C_n\}$  in  $\mathcal{ALN}$ ,  
integer  $k < n$   
**Output** :  $\underline{CS}_k; \underline{ICS}_k; \underline{BICS}; \underline{BCS}$   
1  $\underline{CS}_k := \emptyset; \underline{ICS}_k := \emptyset; \underline{BICS} := \emptyset; \underline{BCS} := \emptyset;$   
2 **foreach**  $D_j$  s.t.  $T_{D_j} \geq k$  **do**  
3  $\underline{CS}_k := \underline{CS}_k \cup \bigcap_{sig_{D_j}}$ ;  
4 **if**  $T_{D_j} < n$  **then**  $\underline{ICS}_k := \underline{ICS}_k \cup \bigcap_{sig_{D_j}}$ ;  
5 **if**  $M_S = n$  **then** **foreach**  $D_j$  s.t.  $T_{D_j} = PM_S$  **do**  $\underline{BICS} := \underline{BICS} \cup \bigcap_{sig_{D_j}}$ ;  
6 **else** **foreach**  $D_j$  s.t.  $T_{D_j} = M_S$  **do**  $\underline{BCS} := \underline{BCS} \cup \bigcap_{sig_{D_j}}$ ;  $\underline{BICS} := \underline{BICS} \cup \bigcap_{sig_{D_j}}$ ;  
7 **return**  $\underline{CS}_k, \underline{BCS}, \underline{ICS}_k, \underline{BICS};$   
**Algorithm 1:** An algorithm for Common Subsumers enumeration

	$D_1$	$D_2$	$D_3$	$D_4$	$D_5$
Nick	1	1	1	0	0
Frank	0	1	1	0	0
Robert	0	0	1	1	0
Fred	1	0	0	0	1

	$R_1$	$R_2$
Nick	1	1
Frank	1	1
Robert	0	1
Fred	0	0

**Figure 1:** Example Collection and Concept Subsumers Matrixes

$\underline{ICS}_k$ , too (line 4). The maximum cardinality is  $M_S = 3$ , so the check in line 5 fails and the flow in line 6 is followed.  $D_3$  is the only concept component with cardinality  $M_S$ : its common signature class, equivalent to  $D_3$  itself, is then added to  $\underline{BCS}$  and  $\underline{BICS}$  (line 6).

### 3.2 Target Core Competence Reaching Evaluation

An approach was proposed in [Colucci et al., 2007a] to evaluate whether a company possesses a given Core Competence, taken as target. The approach implemented an algorithm performing a subsumption check for each profile description in the repository, in order to determine the number of employees holding the target knowledge. We here add to this approach an explanation feature, providing, in case the target is not reached, the reasons why this happens.

Consider a collection of concept descriptions  $C_1, \dots, C_n$  in  $\mathcal{ALN}$ , representing employees knowledge profiles, and a target Core Competence description  $R$ , in  $\mathcal{ALN}$ . In the following, we specialize Definition 7, w.r.t. a concept description  $R$ .

**Definition 9 (Concept Subsumers Matrix)** Let  $C_1, \dots, C_n$  be a collection of concept descriptions  $C_i$  and  $R$  a concept description, both in a Description Logic  $\mathcal{L}$ .

We define the **Concept Subsumers Matrix** as a Subsumers Matrix in which  $D_j \in \{D_1, \dots, D_m\}$  are the concept components of  $R$ , denoted by  $R_j$ .

We here provide Algorithm 2 for evaluation of target Core Competence reaching, with explanation features. The algorithm checks first of all if there are components of the target Core Competence possessed by a number of employees at least equal to the required threshold value  $k$  (line 1). If such a preliminary condition does not hold, an

**Input** : Concept Subsumers Matrix  $S = (s_{ij})$  for a collection of concepts  $\{C_1, \dots, C_n\}$  and a concept  $R$  in  $\mathcal{ALN}$ , integer  $k < n$   
**Output**: Set of Explanations  $E = \{E_l | E_l = \{(C_i, R_j)\}\}$   
**1** if there exists any  $T_{R_j} \geq k$  then compute  $Min = \min\{T_{R_j} | T_{R_j} \geq k\}$ ;  
**2** else  $E = \emptyset$ ;  
**3** foreach  $R_j \in \{R_1, \dots, R_m\}$  such that  $T_{R_j} = Min$  do  
    **4** if  $\bigcap_{sig_{R_j}} \equiv R$  then return  $E = \{\top\}$ ;  
    **5** else foreach  $R_h, h \neq j$  such that  $sig_{R_j} \not\subseteq sig_{R_h}$  do  
    **6**     foreach  $C_i$  do if  $S_{ij} - S_{ih} = 1$  then  $E_l := E_l \cup (C_i, R_h)$   
    **7**      $E := E \cup E_l$ ;  
**8** return  $E$ ;

**Algorithm 2:** An Algorithm for Target Core Competence Reaching evaluation

explanation process makes no sense: there is no component of the target knowledge that belongs to the company know-how. The set of explanations is therefore empty (line 2). If the check does not fail, instead, only components with cardinality equal to  $Min$ , the minimum cardinality bigger than  $k$ , are considered (line 3). The target reaching evaluation process is started from any of these components: if any common signature class embeds all components of  $R$  (line 4),  $R$  is a Core Competence for the company and no explanation is required ( $E = \{\top\}$ , line 4). If the test in line 4 fails, a different explanation process is started from each component  $R_j$  with cardinality equal to  $Min$ , in order to return the set  $E$  of alternative solutions for reaching the target. In particular the test fails if a set of at least  $k$  employees possesses only part of the components of  $R$ . The objective is then that of individuating the employees which could undertake a learning process for the missing knowledge [Colucci et al., 2005]. For this reason, for each component not in the common signature class of the one initially selected (line 5), the employees to train are selected (line 6). The pairs component-employee selected according to the process detailed before are proposed as explanation  $E_l$  (line 6) corresponding to the initial  $R_j$ . The returned set  $E$  is then made up by all the alternative explanation solutions referred to different  $R_j$  with cardinality equal to  $Min$ .

Consider the tiny example running throughout our paper, and the Core Competence *CreativeAssetAllocation*  $\equiv \forall knows.AssetAllocation \sqcap \forall isAbleTo.Creativeness$ . The concept components deriving from  $R$  are  $R_1 = \forall knows.AssetAllocation$  and  $R_2 = \forall isAbleTo.Creativeness$ , and the concept subsumers matrix is given in the right-hand side of Figure 1. If  $k = 2$ , only  $R_1$  is selected in line 3 and, given that the check in line 4 is satisfied, the Core Competence may be considered reached, as shown by the value  $\top$  in the returned explanation set. If  $k = 3$ , instead, only  $R_2$  is selected in line 3; as the check in line 4 fails, in line 5  $R_1$  is selected and, according to the check in line 6, the pair (Robert,  $R_1$ ) is added to  $E_l$ . No other explanation is needed in  $E_l$  which is proposed as the first alternative in the returned explanation set  $E$  (line 7). The loop in lines 3–7 stops because there are no more components satisfying the check in line 3; the only explanation alternative is then the pair (Robert,  $R_1$ ): if Robert acquires Asset Allocation knowledge, the company may reach Creative Asset Allocation Core Competence.

## 4 Conclusions

We have presented a general framework for Core Competence evaluation in knowledge intensive companies. The proposed approach exploits the formalization of company skill sources in a DL knowledge base, which is investigated both for extracting unknown Core Competence and for checking for possession of known one, taken as target. The former process implements specifically introduced DL reasoning services; the latter enriches the check for target Core Competence possession with explanation solutions, suggesting useful learning solutions in case the target is not reached. Both of the approaches are being implemented in the framework of Impakt, a novel and optimized commercial system for competences and skills management [Colucci et al., 2007b], which will be released late this year by D.O.O.M.srl.

## Acknowledgement

This work has been supported in part by EU-FP6-IST-26896 project and Apulia Region funded projects PE\_013 *Innovative models for customer profiling* and PS\_092 *DIPIS*.

## References

- [Baader et al., 2002] Baader, F., Calvanese, D., Mc Guinness, D., Nardi, D., and Patel-Schneider, P., editors (2002). *The Description Logic Handbook*. Cambridge University Press.
- [Barney, 1991] Barney, J. B. (1991). Firm Resources and Sustained Competitive Advantage. *Journal of Management*, 17(1):99–120.
- [Cohen et al., 1992] Cohen, W., Borgida, A., and Hirsh, H. (1992). Computing least common subsumers in description logics. In *Proc. of AAAI-92*, pages 754–760. AAAIP.
- [Cohen and Hirsh, 1994] Cohen, W. W. and Hirsh, H. (1994). Learning the CLASSIC description logics: Theoretical and experimental results. In *Proc. of KR'94*, pages 121–133.
- [Colucci et al., 2005] Colucci, S., Di Noia, T., Di Sciascio, E., Donini, F., and Ragone, A. (2005). Semantic-based automated composition of distributed learning objects for personalized e-learning. In *The Semantic Web: Research and Applications. In Proc. of ESWC '05*, volume 3532 of *LNCS*, pages 633–648. Springer-Verlag.
- [Colucci et al., 2008] Colucci, S., Di Sciascio, E., and Donini, F. (2008). Partial and informative common subsumers of concept collections in description logics. In *Proc. of DL 2008*.
- [Colucci et al., 2007a] Colucci, S., Noia, T. D., Sciascio, E. D., Donini, F., and Ragone, A. (2007a). Measuring core competencies in a clustered network of knowledge. In *Knowledge management: Innovation, technology and cultures*, volume 6 of *Innovation and Knowledge Management*, pages 279–291.
- [Colucci et al., 2007b] Colucci, S., Noia, T. D., Sciascio, E. D., Donini, F., and Ragone, A. (2007b). Semantic-based skill management for automated task assignment and courseware composition. *Journal of Universal Computer Science*, 13(9):1184–1212.
- [Hamel and Prahalad, 1990] Hamel, G. and Prahalad, C. K. (1990). The core competence of the corporation. *Harvard Business Review*, May-June:79–91.
- [L. Halawi and McCarthy, 2005] L. Halawi, J. A. and McCarthy, R. (2005). Resource-Based View of Knowledge Management for Competitive Advantage. 3(2):75–86.
- [Meso and Smith, 2000] Meso, P. and Smith, R. (2000). A Resource-Based View of Organizational Knowledge Management Systems. *Journal of Knowledge Management*, 4(3):224–231.
- [Wernerfelt, 1995] Wernerfelt, B. (1995). The Resource-Based View of the Firm: Ten Years After. *Strategic Management Journal*, 16(3):171–174.

# **Proposing a Framework for Frequently used Terms in Knowledge Management**

**Alexander Hoffmann**

(Johann Wolfgang Goethe-University, Frankfurt a.M., Germany  
alexhfm@wiwi.uni-frankfurt.de)

**Abstract:** In this paper we analyze the meanings and relations of frequently used terms in knowledge management (KM). We start with an overview of the terms data, information, and knowledge, which are mostly seen to be in a hierarchical relation with either knowledge or data on top of the hierarchy. Afterwards, we present the concepts that underlie tacit knowledge, implicit knowledge, and explicit knowledge. Since the meaning of all of these terms varies depending on the author, we give working definitions of the terms and integrate them in a coherent framework, which clarifies and visualizes the relations between data, information, and different types of knowledge. The framework allows researchers to build on a clear terminology concerning frequently used terms in KM, and helps readers of KM literature to gain a better understanding of their meanings and relations.

**Keywords:** Knowledge, Information, Data, Explicit Knowledge, Implicit Knowledge, Tacit Knowledge

**Categories:** H.1.0, M.2

## **1 Introduction**

As a part of KM research, this paper analyzes frequently used terms in the domain of KM and their relations. Since the meaning of the terms tacit knowledge, implicit knowledge, explicit knowledge, data, and information varies depending on the author, the reader has to rethink these terms every time a text in the domain of KM is consulted. Therefore we developed a framework, which explains and integrates these terms and provides a terminological basis for KM research.

## **2 Data, information, and knowledge**

In the KM literature, two major perspectives about the relation between data, information, and knowledge have emerged, each of them seeing these terms in a hierarchical relationship. Depending on the concept, either knowledge or data are defined first and the other terms are subsequently derived from the first term. In this section we will give a short overview of these two perspectives.

The first perspective sees data, information, and knowledge in a hierarchical relationship with knowledge being on top of the hierarchy. That is, data exist first and need to be defined without referring to information and knowledge.

[Davenport and Prusak 1998] see data as “a set of discrete, objective facts about events”. Other authors, referring to facts as well, define data as “facts, images, or

sounds” and “streams of raw facts” [Alter 2002; Laudon and Laudon 2005]. According to [Zack 1999], data are not facts, but represent facts or observations out of a context and are therefore “not directly meaningful”. The observation aspect of data can be found in other approaches as well, where data is regarded as “observations of states of the world” and records of events or facts [Davenport and Prusak 1997; Curtis and Cobham 2005]. Following [Beer 1979], facts are “that which is the case” or whatever is given. It is widely accepted that data consist of symbols [Greschner and Zahn 1992; Krcmar 2005; van der Spek and Spijkervet 2005] that have to be arranged in a meaningful way following the rules of a code or syntax [North 2002]. Some authors propose that data can be seen as not yet interpreted symbols, and that interpreted symbols are “more” than data [Aamodt and Nygard 1995; van der Spek and Spijkervet 2005].

Based on the idea that interpreted symbols are more than data, [van der Spek and Spijkervet 2005] define information as “data which has been assigned a meaning.” Therefore, information is “interpreted data” or “data with meaning”. [Davenport and Prusak 1998] describe information as data that “change the way the receiver perceives something”. Similarly, [Beer 1979] speaks of information as “that which changes us” and what is “susceptible to action”. Consequently, it depends on the individual who uses data if these data constitute information, since only an individual can tell if he or she was “informed” and changed his or her state of mind. For data to become information, they must be associated with a meaningful context by the interpreter [Kock and McQueen 1998; Zack 1999; Wilson 2002; Krcmar 2005]. Information emerges if data have purpose in the context of a decision process and can be used by people to prepare actions [Greschner and Zahn 1992].

Knowledge can be seen as beliefs and values based on the accumulation of information through experience, communication, or inference [Zack 1999]. Knowledge is created by processing of information through the human mind with information being the resource that is used to gain knowledge [North 2002]. It relies on information and data, which are an instrument for communicating and storing knowledge. Knowledge can also be seen as “learned information” [Aamodt and Nygard 1995]. Processing or learning of information results in “new or modified insight or predictive understanding of the implications of possible action alternatives” [Kock and McQueen 1998]. Knowledge is incorporated information that a person can use purposefully within a decision process because he or she is aware of the effect of the information [Greschner and Zahn 1992; Aamodt and Nygard 1995].

The second perspective sees data on top of a terminological hierarchy, with information and knowledge building the basis for data. In other words: “Data emerge last – only after knowledge and information are available” [Tuomi 1999].

[Wittmann 1979] defines knowledge as beliefs about the truth of linguistic statements. Therefore, knowledge exists only in the mind of a person. According to [Augustin 1990], knowledge involves the processes of comprehension, understanding, and learning and can simply be defined as “what we know” [Wilson 2002]. Knowledge can also be seen as representations of the real or imagined world stored in a physical medium, which can be the human brain or, e.g., any kind of data carrier [Bode 1997].

If knowledge is seen as residing within people, it can be articulated and become verbal or textual. Knowledge, which is verbalized or articulated using oral, written, graphic, or gestural forms is called information [Tuomi 1999; Wilson 2002]. Similarly, [Stenmark 2002] defines information as knowledge that is “articulated and furnished with words”. [Bode 1997] speaks of information as a subset of knowledge that allows the transfer between people and is represented in a human language. [Augustin 1990] argues that an articulated issue can only be called information if this articulation is comprehensible for certain recipients and can be used by at least one recipient.

[Tuomi 1999] states, that “it is commonly known [...], that raw data do not exist”. Knowledge and information must exist first, before data can be collected. Using the already defined terms knowledge and information, data can be defined as a “carrier of knowledge and information” and as manifestations of information, whose basic elements are signs [Augustin 1990; Kock and McQueen 1998]. Data are information that have been formalized in order to be communicated, interpreted or manipulated [Stahlknecht and Hasenkamp 2005]. [Tuomi 1999] speaks of data as the “atoms” of information that can be processed automatically and that have no meaning to be considered in automatic manipulation.

### 3 Explicit, tacit, and implicit knowledge

When using the term knowledge in KM, researchers frequently draw a distinction between tacit and explicit knowledge. In this context, many authors refer to [Polanyi 1958], who introduced the concept of tacit knowledge. His most cited statement is that “we can know more than we can tell” [Polanyi 1958]. It is due to lacking awareness of some knowledge that we are unable to put that kind of knowledge into words.

[Collins 2001] points out that if a person holds tacit knowledge, he or she is not able to “formulate the rules” that are necessary for other persons to instantly have the same knowledge after reading these rules. Tacit knowledge resides within the individual, and the individual can “neither document it in a manual, nor explain it in word to others” [Stenmark 2001]. [Wilson 2002], following Polanyi’s idea of tacit knowledge, states that “tacit knowledge is hidden knowledge, hidden even from the consciousness of the knower.” [Herbig and Büssing 2003], who use the term implicit knowledge instead of tacit knowledge but refer to unconscious knowledge and the work of Polanyi as well, agree by saying that implicit knowledge is “generally not verbalisable since [it is] not conscious”. They distinguish implicit knowledge from explicit knowledge, which is “always aware, reflected [and] working above a subjective threshold” and is therefore verbalisable. According to [Schreyögg and Geiger 2003], transformation of tacit knowledge into an explicit form is basically not possible.

[Nonaka and Takeuchi 1995] pick up Polanyi’s idea of tacit knowledge, but see tacit knowledge as basically expressible but not yet expressed. In general, tacit knowledge has a “personal quality” and is hard to formalize and difficult to communicate or to share with others [Nonaka and Konno 1998; Nonaka, Toyama et al. 2000]. This implicates that tacit knowledge is knowledge that a person is conscious of but that is just difficult to express.



Other authors follow the notion of tacit knowledge as not yet codified but basically expressible knowledge and diverge from Polanyi's original idea [Davenport, De Long et al. 1998; Krcmar 2005]. "Tacit knowledge thus has come to signify an absolute type, namely: ,not codified knowledge'" [Cowan, David et al. 2000].

According to [Nonaka and Takeuchi 1995], articulation of tacit knowledge results in metaphors, analogies, concepts, hypotheses or models that exist outside the knower's mind. The result of this process is explicit knowledge "in the form of data, scientific formulae, specifications, manuals and the like" [Nonaka and Konno 1998]. Other authors follow this view and consider explicit knowledge as articulated, transferable, and existing in archivable form [Nonaka, Umemoto et al. 1996; Stenmark 2001; Schreyögg and Geiger 2003].

#### 4 The data-information-knowledge cycle

In this section we will integrate the previously discussed terms in a coherent framework (see Figure 1), which might provide a useful terminological background in the domain of KM and information systems research in general. We propose that both discussed perspectives of knowledge, information, and data are not mutually exclusive, but can be integrated in a circular relation. Further, we propose that the concepts of tacit, implicit, and explicit knowledge can be integrated in this circular relation.

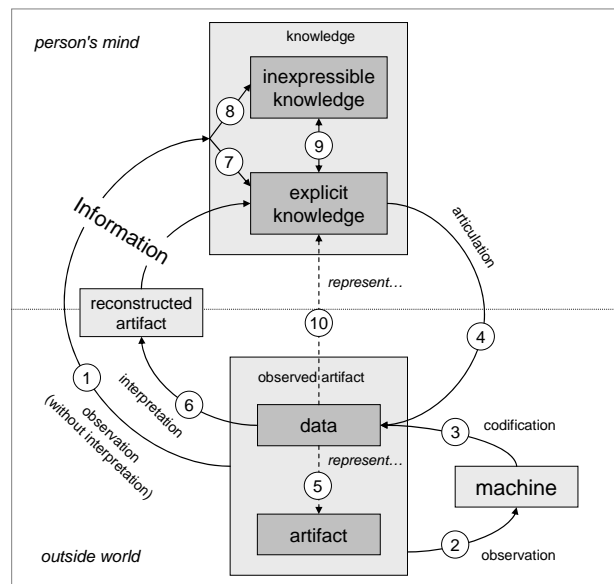

Figure 1: The data-information-knowledge cycle.

Considering Section 3, three different aspects are important in the discussion about explicit and tacit knowledge: *Location*, *awareness*, and *expressibility* of knowledge. Table 1 summarizes these previously discussed aspects.

Knowledge			
location	outside world	person's mind	
awareness	awareness independent	aware	unaware
expressibility	already expressed	expressible	inexpressible

Table 1: Classification schema for tacit, implicit, and explicit knowledge.

According to Polanyi, we use the term *tacit knowledge* to refer to knowledge that still resides in a person's mind, that a person is not aware of, and that is therefore inexpressible. If a person does not have proper means of expression, knowledge can be inexpressible, even if that knowledge is held consciously. We speak of *implicit knowledge* if it is inside a person's mind, held consciously, but cannot be expressed. Implicit knowledge is what [Janik 1988] calls "knowledge by acquaintance or familiarity" like sounds or smells.

Following these definitions, tacit knowledge and implicit knowledge both represent knowledge that cannot be expressed by the person that holds the knowledge. We will use the term *inexpressible knowledge* to cover both tacit and implicit knowledge, while keeping in mind that the reasons for inexpressibility can differ.

*Explicit knowledge* is knowledge that is located in a person's mind, that a person is aware of, and that is expressible, since the person has proper means of expression. We stress that explicit knowledge is not used in terms of Nonaka et al., who equate the term with expressed or articulated knowledge located in the outside world. Explicit knowledge is not yet codified knowledge, ready and capable of being expressed.

Considering data, we assume that data do not exist per se. Data have to be "collected" by someone or something. Collection of data requires the observation of an artifact, which can be, e.g., a physical object, a natural phenomenon, social interaction, or other already existing data. Observation does not include interpretation. Observed artifacts are seen as what they really are and not seen as representing something else. Observation can be conducted manually by a human being (1) or automatically by a machine (2).

For observations to become data they have to be made accessible for the outside world. They must either be codified by machines (3) or articulated by human beings (4). While codification of observations is a well defined, algorithmic process, since it is conducted by machines, articulation of observations is not well defined, since it depends on the individual how observations are processed and represented. The result of codification or articulation of an observation is a representation that is visible to the outside world and accessible intersubjectively.

Thinking of data as codified or articulated observations, they are not identical to the observed artifact, but only represent an artifact (5) and are therefore in a relation to the observed artifact. Data are not "what happened" or "what is", but what was observed and codified or articulated.

Data do not speak for themselves, but have to be interpreted by human beings (6). Interpreting data means to reconstruct the originally observed artifact based on its representation. Depending on a person's understanding of data, the reconstructed artifact can vary. Therefore, it is problematic to speak of data as "objective facts about events" [Davenport and Prusak 1998], since on the one hand the observation of events can be inaccurate and on the other hand the interpretation of the codified observation can diverge from the intended meaning of the used symbols.

However, both interpretation of data and observation of an artifact may change the mind of the observer or interpreter. If the observation or interpretation contains something which is new to a person, he or she "knows" more than before. Therefore, we see *knowledge* as mental concepts that represent observed or reconstructed artifacts. The basis of these mental concepts is, on the one hand, the result of cognitive processing that is triggered by the inflow of new stimuli [Alavi and Leidner 2001]. On the other hand, concepts can be created or modified by applying common rules of conclusion to get insights based on these stimuli [Wittmann 1979]. If interpretation of data or observations of artifacts extend a person's knowledge, we call the "input", which leads to the extension of knowledge, *information*.

Knowledge, which is gained through the interpretation of data, is always explicit, i.e. expressible, since in order to articulate this kind of knowledge, a person could simply reproduce the data, which he or she interpreted before. However, explicit knowledge is not necessarily created by interpretation of data, but can also be based on simple observations (7), if the observer knows enough words to precisely describe the observation.

New inexpressible, i.e. tacit or implicit knowledge, on the other hand, is acquired by observation only (8). An example of gaining inexpressible knowledge is the process of implicit learning, where a person unconsciously conducts observations and gains tacit knowledge, which he or she is not aware of [Herbig and Büssing 2003].

The different states of knowledge may vary from explicit to inexpressible and the other way round (9). In the first case, a person might simply forget how to articulate certain knowledge, and in the second case, a person may learn means of expression that enable him or her to express formerly inexpressible knowledge.

In the previous paragraphs we defined data as codified or articulated observations. Considering the observation, it is possible for a person to be both the observer and the observed artifact, that is, a person self-reflects his or her own thoughts, which may not be based on observations of outside world artifacts, but, e.g., on creative mind activities. For these thoughts to be articulated, they must be explicit knowledge per definition. Therefore, data not only represent artifacts of the outside world, but also explicit knowledge, which is not based on observations of outside world artifacts or interpretation of data (10).

## 5 Conclusion

As our framework shows, knowledge, information, and data can be integrated in a circular relation: a person's knowledge might be extended by observation of artifacts and interpretation of data, which contain something "new" for the person and therefore constitute information. New data, however, can be created by the articulation of explicit knowledge and the codification of observations conducted by

machines. Considering the two hierarchical relations between data, information, and knowledge described in Section 2, our framework merges both hierarchies in a circular relation. Additionally, we proposed a well-defined distinction between tacit, implicit, expressible, and articulated knowledge and integrated these concepts in our framework. It allows future research to build on a clear terminology concerning frequently used terms in KM and helps the readers of KM literature to gain a better understanding of the different meanings and relations of the mentioned terms.

## References

- [Aamodt and Nygard 1995] Aamodt, A., Nygard, M.: "Different roles and mutual dependencies of data, information, and knowledge - An AI perspective on their integration"; *Data & Knowledge Engineering*, 16, 3 (1995), 191-222.
- [Alavi and Leidner 2001] Alavi, M., Leidner, D. E.: "Knowledge Management and Knowledge Management Systems: Conceptual Foundations and Research Issues"; *MIS Quarterly*, 25, 1 (2001), 107-136.
- [Alter 2002] Alter, S.: "Information Systems: Foundation of E-Business"; Prentice Hall, New Jersey (2002)
- [Augustin 1990] Augustin, S.: "Information als Wettbewerbsfaktor: Informationslogistik - Herausforderungen an das Management"; Verlag Industrielle Organisation Zürich, Köln/Zürich (1990)
- [Beer 1979] Beer, S.: "The Heart of Enterprise"; John Wiley and Sons Ltd, Chichester at al. (1979)
- [Bode 1997] Bode, J.: "Der Informationsbegriff in der Betriebswirtschaftslehre"; *Schmalenbachs Zeitschrift für betriebswirtschaftliche Forschung*, 49, 5 (1997), 449-468.
- [Collins 2001] Collins, H. M.: "What is tacit knowledge?" *The Practice Turn in Contemporary Theory*. T. Schatzki, K. Cetina and E. von Savigny. Routledge, London (2001).
- [Cowan, David et al. 2000] Cowan, R., David, P. A., et al.: "The Explicit Economics of Knowledge Codification and Tacitness"; *Industrial and Corporate Change*, 9, 2 (2000), 211-252.
- [Curtis and Cobham 2005] Curtis, G., Cobham, D.: "Business Information Systems: Analysis, Design and Practice"; Prentice Hall, London, New York (2005)
- [Davenport, De Long et al. 1998] Davenport, T. H., De Long, D. W., et al.: "Successful Knowledge Management Projects"; *Sloan Management Review*, 39, 2 (1998), 43-57.
- [Davenport and Prusak 1997] Davenport, T. H., Prusak, L.: "Information Ecology - Mastering the Information and Knowledge Environment"; Oxford University Press, New York/Oxford (1997)
- [Davenport and Prusak 1998] Davenport, T. H., Prusak, L.: "Working Knowledge -

- How Organizations Manage What They Know"; Boston, Massachusetts (1998)
- [Greschner and Zahn 1992] Greschner, J., Zahn, E.: "Strategischer Erfolgsfaktor Information". Rechnergestützte Werkzeuge für das Management, Grundlagen, Methoden, Anwendungen. H. Krallmann. Schmidt, Berlin (1992), 9-28.
- [Herbig and Büssing 2003] Herbig, B., Büssing, A.: "Comparison of the role of explicit and implicit knowledge in working"; Psychology Science, 45, 3 (2003), 165-188.
- [Janik 1988] Janik, A.: "Tacit Knowledge, Working Life and Scientific Method". Knowledge, Skill and Artificial Intelligence. B. Göransson and I. Josefson. Springer, New York (1988).
- [Kock and McQueen 1998] Kock, N., McQueen, R.: "Knowledge and Information Communication in Organizations: An Analysis of Core, Support and Improvement Processes"; Knowledge and Process Management, 5, 1 (1998), 29-40.
- [Krcmar 2005] Krcmar, H.: "Informationsmanagement"; Springer, Berlin (2005)
- [Laudon and Laudon 2005] Laudon, C., Laudon, J. P.: "Essentials of Management Information Systems"; Pearson Education, New Jersey (2005)
- [Nonaka and Konno 1998] Nonaka, I., Konno, N.: "The concept of "Ba": Building a Foundation for Knowledge Creation"; California Management Review, 40, 3 (1998), 40-54.
- [Nonaka and Takeuchi 1995] Nonaka, I., Takeuchi, H.: "The Knowledge-Creating Company"; Oxford University Press, New York (1995)
- [Nonaka, Toyama et al. 2000] Nonaka, I., Toyama, R., et al.: "SECI, Ba and Leadership: A Unified Model of Dynamic Knowledge Creation"; 2000, 33, (2000), 5-34.
- [Nonaka, Umemoto et al. 1996] Nonaka, I., Umemoto, K., et al.: "From Information Processing to Knowledge Creation: A Paradigm Shift in Business Management"; Technology in Society, 18, 2 (1996), 203-218.
- [North 2002] North, K.: "Wissensorientierte Unternehmensführung"; Gabler, Wiesbaden (2002)
- [Polanyi 1958] Polanyi, M.: "Personal Knowledge"; Routledge, London (1958)
- [Schreyögg and Geiger 2003] Schreyögg, G., Geiger, D.: "Wenn alles Wissen ist, ist Wissen am Ende nichts?!" Die Betriebswirtschaft, 63, 1 (2003), 7-22.
- [Stahlknecht and Hasenkamp 2005] Stahlknecht, P., Hasenkamp, U.: "Einführung in die Wirtschaftsinformatik"; Springer, Berlin, Heidelberg, New York (2005)
- [Stenmark 2001] Stenmark, D.: "Leveraging Tacit Organizational Knowledge"; Journal of Management Information Systems, 17, 3 (2001), 9-24.
- [Stenmark 2002] Stenmark, D.: "Information vs. Knowledge: The Role of intranets in Knowledge Management". 35th Hawaii International Conference on System Sciences, (2002)

[Tuomi 1999] Tuomi, I.: "Data Is More Than Knowledge: Implications of the Reversed Knowledge Hierarchy for Knowledge Management and Organizational Memory"; *Journal of Management Information Systems*, 16, 3 (1999), 103-117.

[van der Spek and Spijkervet 2005] van der Spek, R., Spijkervet, A.: "Knowledge Management - Dealing Intelligently With Knowledge"; CIBIT Consultants, Utrecht, Netherlands (2005)

[Wilson 2002] Wilson, T. D.: "The nonsens of 'knowledge management'"; *Information Research*, 8, 1 (2002).

[Wittmann 1979] Wittmann, W.: "Wissen in der Produktion". *Handwörterbuch der Produktionswirtschaft*. W. Kern, Stuttgart (1979), 2261-2272.

[Zack 1999] Zack, M. H.: "Managing Codified Knowledge"; *Sloan Management Review*, Summer 1999, (1999), 45-58.

**Special Track on Intelligent Assistance for Self-Directed  
and Organizational Learning**  
**IWL-LOKMOL 2008**

**Eric Ras**

(Fraunhofer Institute for Experimental Software Engineering, Kaiserslautern, Germany,  
Eric.Ras@iese.fraunhofer.de)

**Martin Memmel**

(German Research Center for Artificial Intelligence DFKI GmbH, Kaiserslautern, Germany,  
Martin.Memmel@dfki.uni-kl.de)

**Tobias Ley**

(Know-Center, Graz, Austria,  
tley@know-center.at)

**Stefanie Lindstaedt**

(Know-Center, Graz, Austria,  
slind@know-center.at)

**Dietrich Albert**

(University of Graz, Cognitive Science Section, Graz, Austria,  
dietrich.albert@uni-graz.at)

*Motivation.* In spite of the close relationship between learning and knowledge, there is still a lack of cooperation between the fields of Technology-enhanced Learning (TeL) and Knowledge Management (KM). Paradigms of work-integrated learning and collective intelligence have been suggested to bridge this gap on a conceptual as well as technical level. The first workshops of the IWL and LOKMOL series have shown that KM technologies need to take into account findings from social and educational sciences, to be effective in terms of learning and that learning can profit from KM approaches as well.

In fact, there is a gap between well organized, but monolithic and inert e-Learning material such as courseware on the one hand and dynamic and flexible public or organizational knowledge bases that are often not able to activate learning processes on the other hand. An integration of KM and Technology-enhanced Learning, especially by using context-based and semantic technologies, or social media technologies could dramatically change today's understanding of workplace learning towards lifelong learning fed by dynamically changing public and organizational knowledge repositories.

In addition, Technology-enhanced Learning approaches develop more and more towards responsive intelligent environments that are embedded into the working process of individuals and existing organizational structures. Knowledge management approaches utilize more and more the collective intelligence of communities and seek

to foster organizational learning as a result of networked knowledge. However, these new developments have generated new research challenges which are far from being solved.

One set of challenges is concerned with a tighter integration of working, learning, and collaboration processes at the workplace and their technological support. How can these be intelligently and flexibly supported without imposing too rigid a structure? Several types of models have been suggested to cope with these requirements. Semantic web approaches and Web2.0 technologies have entered the learning domain, but they have yet to find their way into knowledge work practice. Cognitive and educational models, on the other hand, have been mainly applied in educational settings and need to find their way into workplace settings. Another challenge is the personalization of the learning service to the learners' background, knowledge, preferences, and abilities. Here, a crucial issue is the gathering, describing, and reasoning about context information. Research has already been tackling the domain of context, for example related to context description, context matching, or context-based information delivery, but still needs a better integration into KM and e-Learning.

This special track will continue the series of IWL special tracks and LOKMOL workshops and will build upon the results of the previous ones. This joint special track will focus on *intelligent assistance for self-directed and organizational learning*.

*Goals and topics.* IWL-LOKMOL 2008 addresses the vibrant field of technological support for workplace learning, where the goal is a) to support, enable, and exploit learning and collaboration opportunities embedded within the daily work processes of the individual in an intelligent way and b) to repurpose the experiences, work results, and other resources within the organization as learning resources. A special focus is put on novel technological approaches to support workplace learning, such as the application of semantic technologies and social software principles and related technologies. In addition, challenges as well as first requirements are derived to develop intelligent assistance systems for workplace learning.

*Contributions.* The variety of approaches presented in this workshop demonstrates that there is a recognizable trend towards a stronger cooperation between the fields of e-Learning and KM, and that there are ways to narrow the gap between these two related fields by developing intelligent assistance solutions for workplace learning.

The contributions to this workshop showed that the integration of e-Learning and KM is more than just topic-oriented delivery of knowledge chunks by following non-adaptive processes that are prescribed by a centrally managed learning initiatives. In particular, the contributions from the workshop point to the following considerations, which in turn have implications for future research in the area:

- Pedagogical and psychological aspects as well as the adherence of the current context are considered when learning methodologies and learning content is chosen to meet certain learning objectives. Gordon presents an authoring environment which delivers situated narrative learning content based on organizational stories. Pircher et al. present an instrument for supporting decisions about situated eLearning applications.
- Learning objectives are more related to the development of competencies, which are connected to task outcomes, instead of learning specific topics;



learning hierarchies (e.g., skill decomposition methods) are applied to support the connection between e-Learning and KM. This is exemplified by the contribution of Nussbaumer, et al. who present a system for visualizing skill structures for planning self-directed learning.

- Solutions that are developed focus more and more on facilitating self-directed and self-organized learning instead of prescribed instructions provided by the system. Again, the paper by Nussbaumer et al. can be cited as an example.
- Some of the presented approaches are more flexible in the way that they are based on heuristics instead of descriptive frameworks and the adaptation of instruction during run-time seems to be a promising approach. Lohmann et al., for instance, present tagging as a light-weight approach to annotating learning resources.
- Finally, learning is not just enabled by providing content and using the right methods but also by enabling learning through the involvement of individuals in purposive activities and real working tasks (see the contribution by Gordon on the use of story telling technologies for organizational learning).

As is perhaps always the case in research of this kind, more empirical research is necessary to validate the latest developments in the field of integrated e-Learning and KM. Further workshops like IWL-LOKMOL are essential to keep the community informed about recent developments in this research field and to keep the integration process ongoing.

### Organizers

- Stefanie Lindstaedt, Know-Center, Graz (Austria)
- Tobias Ley, Know-Center, Graz (Austria)
- Martin Memmel, DFKI, Kaiserslautern (Germany)
- Eric Ras, Fraunhofer IESE, Kaiserslautern (Germany)
- Dietrich Albert, University of Graz (Austria)

### Program Committee

- Maria Bannert, TU Chemnitz, Germany
- Thomas Herrmann, University Bochum, Germany
- Robert de Hoog, University of Twente, Learning Sciences, Netherlands
- Andrea Kienle, Fraunhofer IPSI, Darmstadt, Germany
- Barbara Kieslinger, Centre for Social Innovation (ZSI), Vienna, Austria
- Ralf Klamma, RWTH Aachen, Germany
- Jan Pawlowski, Information Technology Research Institute (ITRI), University of Jyväskylä, Finland
- Wolfgang Prinz, RWTH Aachen and Fraunhofer FIT, Germany
- Uwe Riss, SAP Research, Karlsruhe, Germany
- Sandra Schaffert, Salzburg Research, Austria
- Andreas Schmidt, Forschungszentrum Informatik, Karlsruhe, Germany

- Marcus Specht, Open University of the Netherlands
- Silke Steinbach-Nordmann, Fraunhofer IESE, Kaiserslautern, Germany
- Stephan Weibelzahl, National College of Ireland, Dublin, Ireland
- Fridolin Wild, Vienna University of Economics and Business Administration (WUW), Austria
- Martin Wolpers, Fraunhofer FIT, Germany
- Volker Wulf, University of Siegen and Fraunhofer FIT, Germany
- Volker Zimmermann, imc AG, Saarbrücken, Germany

## **Management of Situated E-learning in Organizations**

**Lukas Zenk**

(Danube University Krems, Krems, Austria  
lukas.zenk@donau-uni.ac.at)

**Richard Pircher**

(University of Applied Sciences bfi Vienna, Vienna, Austria  
richard.pircher@fh-vie.ac.at)

**Eva Mayr**

(Danube University Krems, Krems, Austria  
eva.mayr@donau-uni.ac.at)

**Hanna Risku**

(Danube University Krems, Krems, Austria  
hanna.risku@donau-uni.ac.at)

**Abstract:** Complex products and services require both the sophisticated knowledge of individuals on the one hand and collective collaboration between various disciplines and teams on the other. Work-related individual and organizational learning processes in organizations appear to provide the foundations for such individual and organizational knowledge and capabilities. These interconnected learning processes would also seem to be situated in both a social and a physical environment. This paper proposes a methodology for managing situated individual and organizational learning. Empirical results from a questionnaire and two test bed organizations are presented and conclusions drawn from the assessment results on recommended measures for the use of e-learning.

**Keywords:** organizational learning, e-learning, learning design, work-related learning, didactics

**Categories:** L.2.5

## **1 Introduction**

### **1.1 Individual and Organizational Learning**

Individual and organizational learning in the workplace are interconnected processes ([Kim, 93] [Schwaninger, 06]). They influence each other substantially and are difficult to differentiate. Since the late 1980s, literature has become available which recognizes not only the impact of the individual, but also the impact of the organization on individual learning processes and/or training success. Several authors in the Human Resource Development (HRD) field analyze organizational factors affecting work-related learning (e.g. [Chiaburu, 05b], [Chiaburu, 05a], [Russ-Eft, 02], [Gardiner, 99], [Confessore, 98], [Tannenbaum, 97]).

## 1.2 Situated Learning

To study the transfer of knowledge and skills in organizations, we must first clarify the *nature of such knowledge and capabilities*. From a mechanistic point of view, knowledge and capabilities can be regarded as easily transferable commodities. However, research findings suggest that the use of data and information in organizations depends on the subjective interpretation of those individuals and groups who transform this input into actions and results. Particular emphasis is given to this aspect in *situated approaches* to knowledge and learning [Lave, 91]. Within the situated approach, it has been proposed that companies must seek to influence and support knowledge management capabilities in several different areas (e.g. leadership and company culture) by deploying and integrating the available methods, instruments and technologies to provide a *beneficial environment* for the use and creation of knowledge and competencies. In doing so, they must also actively encourage and support participation in learning activities ([Poell, 04]). Since individuals can be seen as operating both independently and interdependently, their socially-derived personal histories, values and ways of knowing mediate the way they participate and learn in the workplace. They need to find meaning and value in the learning activities offered. Inconsistencies between *organizational and individual values* may lead to resistance to training. Different ways of motivating are required, for example, to attract the interest of and encourage the participation of reluctant employees. Opportunities to participate in the decision processes and learning activities as well as receive support for learning are essential for rich learning outcomes [Billett, 01].

Approaches like situated learning emphasize the *social context of learning processes* and regard knowledge as socially constructed [Lave, 91]. Working as such is recognized as a source of learning and informal learning does indeed occur in work processes. Consequently, a shift from training to learning can be observed in the field of HRD: “Learning arrangements closely linked to the workplace are at the center of attention, for example, mentoring, self-study, learning-by-doing, intercollegiate consultation, special work assignments, reflection-in-action, work-related learning projects, coaching, and work experiments” ([Streumer, 04], quoted in [Poell, 04]). An organization’s potential to provide a supportive learning environment depends very much on the way work is organized in that organization and on the actual work processes involved ([Ashton, 02], p. 160). Consequently, the complete working and learning context must be analyzed: “if we are to further our understanding of the process of workplace learning then we must move beyond a narrow focus on the process of interaction in the immediate workplace that has characterized recent research” ([Ashton, 02], p. 160).

## 1.3 Objective

The objective of our project is to define an empirically validated model of those organizational dimensions which have an impact on individual and organizational learning processes (Model of Organizational Dimensions - MOD). An assessment methodology based on this MOD supports the analysis of an organization’s learning situation. The results of such analyses serve as input and provide decision support for

didactic strategies and management measures. This particular paper focuses on decision support for the application of e-learning.

## **2 Methodology**

Based on an initial literature based version of the MOD, a questionnaire – the Learning Assessment Guideline (LAG) – was developed ([Pircher, 07], [Pircher, 06]). The LAG assesses the organizational factors relevant for individual and organizational learning. Research findings from the fields of HRD and Organizational Learning/Knowledge Management (OL/KM) were used to generate an initial item pool. The design and evaluation of the LAG in the chosen test environments was spread over two empirical phases. In the first phase, face-to-face and written interviews with managers provided information relevant to the implementation of process-oriented learning with a focus on the management perspective. Results from these interviews were used in the second phase to develop an online survey to gather information on the employee perspective on workplace learning.

A pool of 129 items was developed based on both the literature review and the interviews with managers. A subsequent online survey was conducted in January and February 2008 using this item pool. Overall, 191 employees from 5 different organizations completed the LAG. 30 of these respondents were subsequently excluded as their responses were incomplete. The actual data obtained was used to analyze the structure of the questionnaire and select appropriate items with good test statistics.

Orthogonal factor analysis with Varimax rotation revealed seven factors (accounting for 57 % of the overall variance). To reduce the complexity of the factor structure, items loading substantially on more than one factor were excluded. Within each factor, a reliability analysis was conducted for the remaining items. Items which correlated with a factor score of less than .30 were successively excluded.

## **3 Learning Assessment Guideline**

The final scales exhibited satisfactory reliabilities (Cronbach's Alpha) between .64 and .92. Consequently, the final version of the LAG contains 57 items relating to 7 factors: organizational learning orientation (OLO, 21 items), e-learning orientation (ELO, 9 items), problems with prior work-based training courses (PPT, 7 items), extrinsic motivation for work-based training courses (EMT, 7 items), workload (WL, 5 items), work-orientation of training courses (WOT, 4 items), and face-to-face learning orientation (FLO, 4 items).

To further validate the organizational nature of the dimensions assessed by the LAG, intraclass correlations (ICC) were computed for each scale on an organizational level. High intraclass correlations indicate very similar scale values within an organization. This analysis confirmed that the LAG assesses predominantly organizational factors: OLO, ELO, WL, and WOT are significantly correlated within the organization. EMT is correlated within organizations, but did not gain significance due to the sample size. Interestingly, PPT and FLO seem to feature more on an individual than on an organizational level.

#### 4 Empirical Results from Two Organizations

To visualize the assessment obtained using the LAG, data from two organizations, one from the telecommunication sector and one from the healthcare sector, was further analyzed and compared. 20 employees from the telecom company (mean age = 37.42 yrs, mean length of service in company = 5.83 yrs, 11 % management) and 25 employees from the healthcare company (mean age = 43.25 yrs, mean length of service in company = 17.26 yrs, 27 % management) completed the questionnaire. As the descriptive characteristics of both samples show, these companies differ greatly both in employee age and frequency of employee change. Despite these descriptive differences the two companies are fairly similar in many of the LAG scales (WL, EMT, FLO, PPT, WOT, cp. Fig. 2).

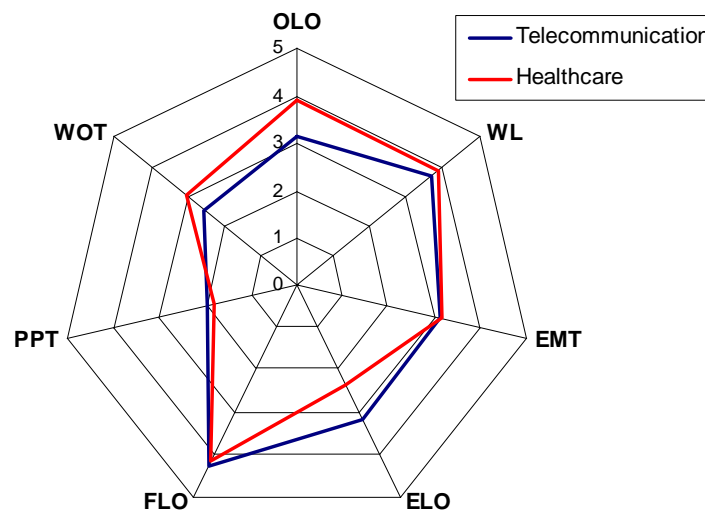

Figure 1: Assessment results from the telecommunication and healthcare sectors

However, the comparison also shows substantial differences in three scales. Results for the healthcare organization, for instance, show a higher degree of organizational learning orientation (OLO). In contrast, the telecommunication company has a higher e-learning orientation (ELO).

A comparison of the LAG values for each of these two companies with other organizations shows that the healthcare company has a significantly lower e-learning orientation, but a higher overall organizational learning orientation and fewer problems with prior training courses. The telecommunication company has a lower extrinsic motivation than other companies.

## 5 Decision Support for the Application of E-Learning

There is still a lack of research on the correlation of organizational characteristics and suitable didactic measures. However, based on our literature survey and analysis, a number of factors were identified which appear to be linked to this issue. Through the empirical work carried out in the EU project PROLIX (Process oriented learning and knowledge exchange), we identified different factors relevant for e-learning in organizations. In the following section, we will discuss how each of the seven LAG factors relates to the introduction of e-learning and which management measures can be employed to improve these organizational characteristics.

A minimum prerequisite for the application of e-learning in an organization is a moderate *e-learning orientation (ELO)*. An e-learning orientation as assessed in the LAG means the availability of the required infrastructure and a sufficient level of IT skills among employees. If an organization's ELO is low, the introduction of e-learning should be delayed until these requirements are met. From a management perspective, the potential strategic benefit of e-learning should be analyzed in combination with work-based learning ("blended learning"). Strategic measures can be developed by focusing on the main advantages and challenges of e-learning.

*Workload (WL)* is also particularly relevant for e-learning. E-learning courses are often done at the workplace, so learning usually does not take place at a specified time, but when a person has some spare time to do so. People with heavy workloads have little time to participate in e-learning and often no time to transfer the individual knowledge gained to actual work processes for organizational learning purposes. The success of and participation in such training programs could be increased by a temporary reduction in workload. Management must ensure that participation in training activities does not have significant negative consequences for employees, such as substantially increased time pressure.

An *organizational learning orientation (OLO)* is a prerequisite for the success of all forms of work-based training. Individual learning will only have an impact at an organizational level if an organization is prepared to encourage its employees to make use of their newly acquired knowledge. In cases where the organization's OLO is low, management could take steps to improve the situation by developing employee competencies and explicitly encouraging employees through their line managers to participate in training activities (e.g. a "dual ladder" [van Wees 94] or "walk the talk" [Sveiby 07] approach). Another possible option would be to provide an overview of the available internal and external knowledge (e.g. Yellow Pages, Blue Pages) and the knowledge needed in the organization (competence matrix).

If an organization has already introduced different forms of training, the factors *problems with prior work-based training courses (PPT)* and *work-orientation of training courses (WOT)* provide information on the suitability of such training in that particular organization. A high PPT value indicates that training courses did not meet the expectations and requirements of employees and that a change of didactic strategy is recommended. In such cases, a first step would be to evaluate, for example, the qualifications of the trainers, assess the types of courses used and determine whether the prior knowledge of the employees fitted the requirements of the courses. A low WOT value indicates that training courses were not sufficiently work related and that employees did not find the training topics relevant to their particular work

requirements. Knowledge is not likely to be transferred if the training available is not work-oriented and employees are thus not intrinsically motivated or encouraged to do so by their line managers. To increase the WOT and the transfer of the material learned, the topics and didactic methods used should be adapted to better suit the working environments and tasks of the employees. If not, management should offer employees support in transferring the knowledge acquired in training courses to their actual work processes.

The factor *face-to-face learning orientation* (FLO) is not relevant for the introduction of e-learning. Employees are prepared (or not) for e-learning independent of their preference for face-to-face learning (or not).

Last but not least, the factor *extrinsic motivation for training* (EMT) indicates the extent to which an organization values the training efforts of its employees. Too few incentives may result in only those employees who are highly intrinsically motivated participating in training courses. While few incentives may be needed for voluntary e-learning because a high degree of intrinsic motivation is conducive to investing time and effort in learning on one's own at a computer, extrinsic incentives should nonetheless be provided for compulsory computer-based training courses. Such incentives will motivate employees to invest their time and effort in training and thus encourage individual and organizational learning. However, care should be taken not to offer overly high extrinsic incentives, as these could reduce intrinsic motivation.

By applying this decision support to the two organizations described above, the results of the LAG indicate that the learning environment at the telecommunication company is suited to e-learning: employees report a high level of ELO, thereby indicating that IT skills and the necessary infrastructure for e-learning are available. To increase employee motivation to participate in training and transfer their acquired knowledge to the workplace, the introduction of training incentives is recommended.

In contrast, the introduction of e-learning at the healthcare company cannot be recommended, due to the low ELO level. If e-learning were to be implemented in the future, the management would have to first improve its technical infrastructure and provide courses to raise the level of IT skills among its employees. However, the company does have a high overall OLO, which is beneficial for individual and organizational learning at the workplace. As only limited PPT were reported for this company, we recommend that it basically maintains its existing didactic strategy. Should the company plan to introduce e-learning, it should first weigh up the benefits against the costs.

## 6 Conclusions

The perception of learning as a situated process has been transferred here to a further objective, namely the strategic management of e-learning. On this basis, the specific organizational context of e-learning had to be analyzed and taken into account. A literature based model of relevant characteristics was tested empirically, resulting in an assessment that included 7 factors and 57 items. By means of example, we used the results for two separate organizations to demonstrate how an organizational learning environment assessment conducted using the LAG can provide decision support for the introduction of e-learning. By taking its specific characteristics into account, suggestions for appropriate management measures and didactic support can be



provided that enable an organization to define a training strategy specifically tailored to its own particular needs.

## 7 Future Work

A next step in our research will be to test and refine the decision support by implementing it in several organizations. The final version of the decision support will then be evaluated by training designers and managers in different organizations with regard to usability and practical relevance.

To date, the decision support only provides advice for “high” or “low” values on the LAG scales. To provide a quantitative threshold for both extremes in the seven factors, we plan to use the LAG in the test beds and other organizations to generate a large data pool for the LAG to serve as reference distribution.

### Acknowledgements

The presented research was conducted within the context of the EU project PROLIX (Process oriented learning and knowledge exchange) with financial support from the European Union.

### References

- [Ashton, 02] Ashton, D.: The dynamics of workplace learning: the role of work organizations, In Evans, K.; Hodkinson, P.; Unwin, L. (Ed.): *Working to Learn: Transforming Learning in the Workplace*, London: Routledge, p. 149 - 162
- [Billett, 01] Billett, S.: Learning through work: workplace affordances and individual engagement, *Journal of Workplace Learning*, 13 No. 5, p. 209 - 214
- [Chiaburu, 05a] Chiaburu, D. S., Marinova, S. V.: What predicts skill transfer? An exploratory study of goal orientation, training self-efficacy and organizational supports, *International Journal of Training and Development*, 9:2, p. 110 - 123
- [Chiaburu, 05b] Chiaburu, D. S., Tekleab, A. G.: Individual and contextual influences on multiple dimensions of training effectiveness, *Journal of European Industrial Training*, Vol. 29 No. 8
- [Confessore, 98] Confessore, S. J., Kops, W. J.: Self-Directed Learning and the Learning Organization: Examining the Connection Between the Individual and the Learning Environment, *Human Resource Development Quarterly*, Vol. 9. no. 4, p. 365 - 375
- [Gardiner, 99] Gardiner, P.: Soaring to new heights with learning orientated companies, *Journal of Workplace Learning*, Vol. 11 No. 7, p. 255 - 265
- [Kim, 93] Kim, D. H.: The Link between Individual and Organizational Learning, *MIT Sloane Management Review*, Fall 1993, p. 37 - 50

- [Lave, J., 91] Lave, J., Wenger, E.: *Situated learning*, Cambridge: Cambridge University Press
- [Pircher, 06] Pircher, R., Risku, H.: The impact of the organizational environment on process-oriented workplace learning E-competencies for Life, Employment and Innovation "E" is more! E-learning Enabling Education in Evolving Europe, conference proceedings EDEN 2006, p. 750 - 755
- [Pircher, 07] Pircher, R., Zenk, L., Risku, H.: Context assessment as a basis for appropriate support of individual and organizational learning: 3rd Workshop on Learner-Oriented Knowledge Management & KM-Oriented E-Learning (LOKMOL 2007), <http://www.dfki.uni-kl.de/~memmel/ectel2007/> [29. 10. 2007]
- [Poell, 04] Poell, R. F., van Dam, K., van den Berg, P. T.: Organising Learning in Work Contexts, *Applied Psychology*, 53 (4), p. 529 - 540
- [Russ-Eft, 02] Russ-Eft, D.: A Typology of Training Design and Work Environment Factors Affecting Workplace Learning and Transfer, *Human Resource Development Review*, Vol. 1 No. 1, p. 45 - 65
- [Schwaninger,06] Schwaninger, M.: *Intelligent Organizations - Powerful Models for Systemic Management*, Berlin: Springer
- [Streumer, 04] Streumer, J. N.: (Ed.) *Work-Related Learning*, Dordrecht: Kluwer
- [Sveiby 07] Sveiby, K. E. (2007). Disabling the context for knowledge work: the role of managers' behaviours. *Management Decision*, 45(10), 1636-1655.
- [Tannenbaum, 97] Tannenbaum, S. I.: Enhancing continuous learning: diagnostic findings from multiple companies, *Human Resource Management*, Vol. 36 No. 4, p. 437 - 452
- [van Wees 94] van Wees, L., & Jansen, P. (1994). Dual ladder "in balance". *The International Journal of Career Management*, 6(3), 11-19.

# Visualisation Tools for Supporting Self-Regulated Learning through Exploiting Competence Structures

**Alexander Nussbaumer**

(University of Graz, Department of Psychology, Graz, Austria  
alexander.nussbaumer@uni-graz.at)

**Christina Steiner**

(University of Graz, Department of Psychology, Graz, Austria  
christina.steiner@uni-graz.at)

**Dietrich Albert**

(University of Graz, Department of Psychology, Graz, Austria  
dietrich.albert@uni-graz.at)

**Abstract:** In this paper an approach is presented how self-regulated learning can be supported and stimulated by visualising knowledge and competence structures in order to provide visual guidance in the learning process. In the field of adaptive systems and related research techniques of intelligent guidance have been developed, which, however, may have the disadvantage of limiting the learner. On the other hand, self-regulated learning gives greater control and responsibility to the learner, however, especially weak learner may have difficulties without provision of guidance. The presented approach combines both offering guidance and granting control over the own learning process. A set of learning tools have been developed which implement and demonstrate the proposed approach. Since knowledge structuring and knowledge visualisation are well established in the field of knowledge management, this approach can be exploited to bridge the research fields of e-learning and knowledge management.

**Keywords:** adaptive system, adaptivity, self-regulated learning, skill, competence, Knowledge Space Theory, information visualisation, human-computer interface

**Categories:** H.5.2, L.3.1, L.3.4, L.3.6

## 1 Introduction

Presently, two important strands of e-learning research can be observed: First, *adaptivity and personalisation* provided by adaptive systems capable of tailoring content and behaviour to characteristics and needs of learners, and second, *self-regulated learning*, a pedagogical approach which claims to give more control and responsibility to the learner. The first strand, adaptive systems, has its origin in technological developments (computer systems, Internet, hypermedia) and is characterised by research how technology can support and guide the learning process. This approach to e-learning holds the risk of having the learning process to a large extent controlled by the system. If the models or structures underlying system behaviour are invalid, however, the guidance provided by the system is actually worse than no guidance [De Bra, 2000]. In contrast, the second research strand, self-

regulated learning, has its origin in pedagogical learning theories and focuses rather on the learning process of learners than on technology. Self-regulated learning, however, requires the ability to autonomously define learning goals and paths, which an individual not necessarily possesses [Baumgartner and Payr, 1994]. Especially novices and beginners in a knowledge domain therefore need some support in directing their learning [Ley, 2006]. Besides, the tradition of self-regulated learning is not grounded on formal models that would be needed for technical implementation.

The approach presented in this paper combines these two research strands in order to make use of the advantages of both for the learner's benefit. A set of tools has been developed which follow and demonstrate this approach. Research and development of these tools are part of the iClass research project [iClass, 2008]. The aim was to support a self-regulative learning cycle, which according to [Zimmerman, 2002] consists of forethought (planning), performance (monitoring) and reflection. The developed tools support the planning and reflection processes, performance (viewing learning objects) is done by other iClass components.

The next section gives an overview on the research fields which are basis for our approach. [Section 3] gives a more detailed description of our approach and presents the developed tools. Selected development details and integration into the iClass system are described in [Section 4]. Future work and conclusion can be found in [Section 5].

## 2 Theoretical foundation and related work

### 2.1 Adaptivity and adaptive systems

The concept of *adaptivity* has a long tradition in technology-enhanced learning, for example it has been applied in Intelligent Tutoring Systems (ITS) to some extent, user-model-based Adaptive Systems (AS), and Adaptive Hypermedia Systems (AHS) [Brusilovsky, 2000]. Following the discussion in [Brusilovsky, 1996 and De Bra et al., 2004], users (learners) differ in terms of (learning) goals, pre-knowledge, individual traits and needs, as well as pedagogical parameters. Based on these characteristics adaptive presentation (adaptation on the content level) and adaptive navigation support (direct guidance, adaptive ordering, hiding, and annotation of links) are the most important features which can be provided by an adaptive system. Domain models and user models are defined in order to specify relationships between users and content, which forms the basis for the adaptation functionality. In educational applications these relationships typically represent the knowledge about learners and content. Furthermore, adaptive systems usually contain adaptation models which determine the adaptation strategy of those systems. In this way an adaptive system can help the learner to navigate through a course by providing user-specific paths.

### 2.2 Competence-based Knowledge Space Theory (CbKST)

Knowledge Space Theory (KST) and its competence-based extensions (CbKST) are prominent examples how an adaptation strategy can be grounded on a theoretical framework [Hockemeyer, 2003]. KST constitutes a sound psychological

mathematical framework for both structuring knowledge domains and for representing the knowledge of learners. Due to (psychological) dependencies between problems prerequisite relations can be established. The knowledge state of a learner is identified with the subset of all problems this learner is capable of solving. By associating assessment problems with learning objects, a structure on learning objects can be established, which constitutes the basis for meaningful learning paths adapted to the learners knowledge state. Competence-based Knowledge Space Theory (CbKST) incorporates psychological assumptions on underlying skills and competencies that are required for solving the problems under consideration. This approach assigns to each problem a collection of skills which are needed to solve this problem and to each learning objects those skills which are taught. Similar to the knowledge state a competence state can be defined which consists of a set of skills which the learner has available. Furthermore, there may also be prerequisite relationships between skills. CbKST provides algorithms for efficient adaptive assessment to determine the learner's current knowledge and competence state, which builds the basis for personalization purposes. Based on this learner information, personalised learning paths can be created.

### **2.3 Self-regulated Learning**

Self-regulated learning has become increasingly important in educational and psychological research. Compared to adaptive learning systems, the tenor in self-regulated learning is to give the learner greater responsibility and control over all aspects of (technology-enhanced) learning. There are only few attempts trying to build a complete model of self-regulated learning [Puustinen and Pulkkinen, 2001]. Most of these models deal with self-regulation as a process that involves goal setting and planning, monitoring and control processes, as well as reflection and evaluation processes. From this it becomes apparent that self-regulation is closely related to meta-cognitive strategies. In [Dabbagh and Kitsantas, 2004] six self-regulatory processes and their significance to Web-based learning tools have been identified. For example (a) goal setting is supported by communication tools, such as e-mail communication with a tutor, (b) the use of task strategies is supported by content delivery tools, such as concept mapping software to organise course content, (c) self-monitoring is supported by use archived discussion forums, (d) self-evaluating is supported by the use of rubrics, evaluation criteria, and peer feedback, (e) time planning and management is supported by communication tools concerning time budgeting, and (f) help seeking is supported by hypermedia tools.

### **2.4 Information and knowledge visualisation**

The abilities of humans to recognise visual information are highly developed. Patterns, colours, shapes and textures can rapidly and without any difficulty be detected. On the other hand, the perception of text-based content is much more effort than the perception of visual information [Shneiderman, 1996]. Information visualisation is the transformation of abstract data and information into a form that can be recognised and understood by humans. In this sense, information visualisation can be seen as an interface to abstract information spaces. So exploring large volumes of data can be done effectively by humans.

Information visualisation techniques are widely used in Web-based social software (e.g. graph visualisation is used to outline online community networks and tag clouds are often used to provide overview on collaboratively tagged Web content) and especially in knowledge management (e.g. visualisation of large knowledge structures for providing overview and interface to it). In contrast to these application areas, information visualisation is barely used in e-learning applications.

### 3 Tool description and learning cycle

#### 3.1 Combined approach

Though the approaches described in [Section 2] are rather different, they can be combined to a uniform and new approach taking advantage from each side. The approach of adaptive systems is based on user and domain models which are used to provide guidance by exploiting an adaptation model [Figure 1a]. The approach of self-regulated learning is based on mental learning processes of the learner and describes which tools support the respective processes [Figure 1b].

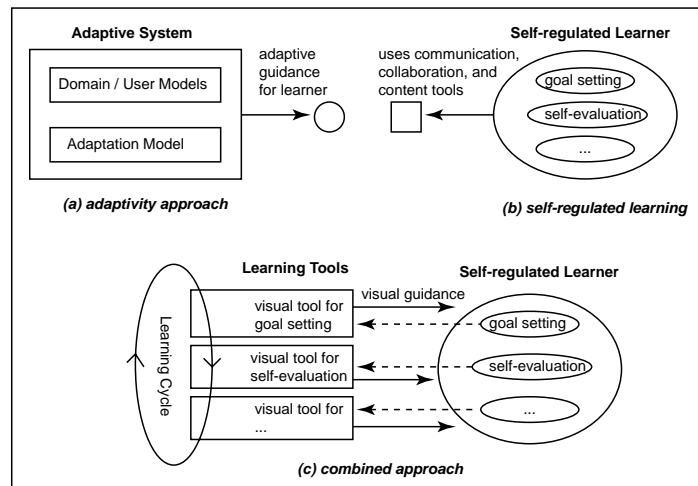

Figure 1: Combined approach based of adaptive systems and self-regulated learning.

The combined approach is to create learning tools, whereby each tool is related to a specific learning process in terms of self-regulated learning [Figure 1c]. The set of these tools represents a whole learning cycle and supports self-regulated learning as a whole. The tools employ user and domain models for two purposes: First, the

domain and user models are visualised (through various information visualisation techniques), and second, guidance based on the adaptation model is granted also in a visual way, rendered on the same or additional visualisations. Hence, the same kinds of models which are used by adaptive systems are presented to the learner in an easily understandable manner. This empowers the learner to take over control from an

adaptive system while being supported by the system through visualised structures and visual guidance.

Domain and user models are based on CbKST [see also Görgün et al., 2005]. The central elements are skills which are assigned to both learning objects and assessment objects. A skill is defined by a set of domain concepts and an action verb which specifies the cognitive processing of the respective concepts (e.g. apply the Pythagorean Theorem). The user knowledge is represented as a set of skills which the learner has available (competence state) and a set of skills which the learner should have available at the end of the learning process (competence goal).

### 3.2 Planning Tool

The Planning Tool [Figure 2] supports the learning processes of *goal setting* and *use of task strategies*. This tool visualises the domain skills and their prerequisite relations as Hasse diagram (similar to directed acyclic graph) with ascending sequences of line segments representing a prerequisite relation. On this graph, skills can be chosen to define the competence goal and subsequently sequenced on the visual plan component. Prerequisite skills of the chosen skills are also added to the plan. If the created sequence of the skills is not in line with the prerequisite structure, this tool gives visual feedback (in terms of coloured skills). Furthermore, it provides the functionality of automatically sequencing the chosen skills corresponding to the prerequisite relations. Furthermore, for each skill learning objects can be searched and chosen which teach the respective skill. As soon as for all skills of the competence goal learning objects have been added to the plan, visual feedback is provided that the plan is complete. Further guidance is granted, as the tool also can propose meaningful sequences of learning objects by using the learning object - skill relation.

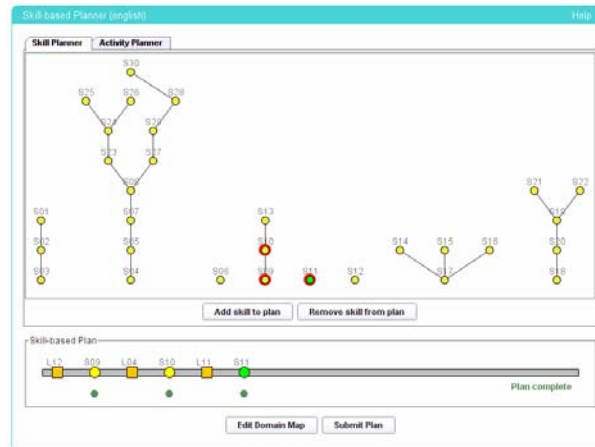

Figure 2: Planning Tool. The figure shows the prerequisite relations on skills and a plan consisting of skills and learning objects.

### 3.3 Adaptive Assessment Tool

An adaptive assessment based on KST [Doignon and Falmagne, 1999] is conducted to determine which skills a learner has available. Questions are posed to the learner taking into account previous answers and exploiting prerequisite relationships among problems. The traditional algorithm calculates the sequence of questions and is capable of posing a minimal number of questions to determine the learner's knowledge. The result of the assessment is a (verified) set of skills (competence state) which the learner has available.

In order to support self-regulated learning, modifications to the algorithms are made, which gives the learner greater control over the assessment procedure: (1) Instead of actually answering the question, the learner may judge whether to be able to solve the respective problem, which supports self-reflection. (2) The learner can determine the difficulty level of the questions. (3) Instead of presenting exactly one question to the learner, the algorithm can present a set of questions and the learner may choose between these questions.

### 3.4 Self-Evaluation Tool

A learner may reflect on what having learned by defining skills which consist of concepts and action verbs. This is done in three steps: (1) The learner is provided with a list of concepts and chooses those concepts that have been covered in the learning process so far. (2) Then the learner self-evaluates for each concept the level of 'expertise'. These levels are indicated by the Bloom taxonomy levels, i.e. the action verbs remember, understand, apply. (3) The combination of concepts and Bloom level action verbs results in skills – defined by the learner.

With this approach during the self-evaluation procedure the learner reflects on what having learned and after the procedure the learner is presented with the skills which result from the self-evaluation procedure. In contrast to the Assessment Tool, this method does not pose questions, but asks directly for learned domain concepts.

### 3.5 Learner Knowledge Presentation Tool

This tool presents the skills which the learner has learned during the learning process. Three sources for this information are used: (1) The skills which have been taught by learning objects are visualised in a chronological order together with the learning objects. (2) The acquired (verified) skills resulted from the adaptive assessment and (3) the skills (non-verified) resulted from the Self-evaluation Tool.

The presentation of skills is done in a visual way, learned acquired skills (verified and non-verified) are rendered in different colours. Furthermore, the competence goal (also defined as set of skills) is rendered in a way that missing skills can be seen immediately. In this way the learner directly monitors his learning progress and skill gap (compared to the competence goal).

### 3.6 Domain Structuring Tool

Creating domain models is usually the task of teachers and domain authors. A tool has been developed which allows for easily creating domain models by again employing visualisation techniques. For example, defining prerequisite relations between skills



can be immediately seen in the prerequisite graph, and assigning skills to learning objects are done in a fish-eye visualisation where all learning objects including the assigned skills are shown and the selected learning object is magnified.

#### **4 Implementation and Integration**

For the implementation of the tools an open and extensible framework has been developed which consists of four pillars: (1) The knowledge representation model is implemented as object-oriented model and can be easily used by the other components. A converter has been created which transforms the domain model into OWL format and vice versa. (2) CbKST algorithms (e.g. assessment algorithm) have been implemented and integrated into the framework. (3) Visual components (e.g. prerequisite relation graph) which rely on the knowledge representation model are implemented as reusable software components. They make use of information visualisation techniques, such as graph drawing and fish-eye distortion. (4) The tools have implemented basic user interfaces and integrate the knowledge representation model, the CbKST algorithms, and the visualisation components.

All implementation is done in Java and almost all parts are developed from scratch (except the OWL parser). Besides using the tools as stand-alone application, they also can be used as Applets, which is needed for the integration into the iClass system. The iClass system is designed as a service-oriented architecture with a Web-based front-end and an application server. Integration into the iClass system is realised in two ways. First, the tools are part of the front-end and are launched from front-end components. Second, the tools make use of the iClass services via SOAP, for example loading and storing domain models is done on the content delivery Web service.

#### **5 Conclusions and Future Work**

In this paper an approach has been presented how self-regulated learning can be supported and stimulated. This approach makes use of concepts of the adaptive systems and related research in order to integrate guidance in self-regulated learning processes. Furthermore, a knowledge representation model (domain and user model) is used as a basis for the guidance. In contrast to adaptive systems, these models are not hidden from the user and only used by the adaptation algorithms, but - and this is seen as the major innovation of this paper - these models are visualised by the learning tools. Through these visualisations the learner can get both guidance and responsibility for his learning process at the same time. Several tools have been developed which exploit this approach in order to support particular self-regulated learning processes.

The presented approach is supposed to have great potential for further work. The research field of information visualisation is lively, which can bring new possibilities of visual guidance. Furthermore, in the field of knowledge management, knowledge structuring and knowledge visualisation are well established. Both are essential for the presented approach and hence, can be exploited to bridge the research fields of e-learning and knowledge management.

Evaluation of usability and learning effectiveness of the developed tools are currently conducted and will be finished before the final review of the iClass project in summer 2008.

## References

- [Baumgartner and Payr, 1994] Baumgartner, P. & Payr, S.: Lernen mit Software [Learning with software]. Innsbruck: Österreichischer Studienverlag.
- [Brusilovsky, 1996] Brusilovsky, P.: Adaptive Hypermedia, an Attempt to Analyze and Generalize, In P. Brusilovsky, P. Kommers, & N. Streitz (Eds.), *Multimedia, Hypermedia, and Virtual Reality (Lecture Notes in Computer Science, Vol. 1077)*. Berlin: Springer-Verlag, 288-304.
- [Brusilovsky, 2000] Brusilovsky, P.: Adaptive hypermedia: From intelligent tutoring systems to Web-based education (Invited talk), In: G. Gauthier, C. Frasson and K. VanLehn (eds.) *Intelligent Tutoring Systems. Lecture Notes in Computer Science, Vol. 1839, (2000)*, pp. 1-7, Berlin: Springer Verlag.
- [Dabbagh and Kitsantas, 2004] Dabbagh, N., & Kitsantas, A: Supporting Self-Regulation in Student-Centered Web-Based Learning Environments, In: *International Journal on E-Learning*, 3(1), (2004), pp. 40-47.
- [De Bra, 2000] De Bra, P.: Pros and Cons of Adaptive Hypermedia in Web-Based Education, In: *Journal on CyberPsychology and Behavior*, 3(1), (2000), pp. 71-77, Mary Ann Lievert Inc.
- [De Bra et al., 2004] De Bra, P., Aroyo, L., Cristea, A.: Adaptive Web-based Educational Hypermedia, In: Mark Levene, Alexandra Poulouvassilis (Eds.) *Web Dynamics, Adaptive to Change in Content, Size, Topology and Use, (2004)*, pp. 387-410, Springer-Verlag.
- [Doignon and Falmagne, 1999] Doignon, J.-P., & Falmagne, J.-C.: *Knowledge spaces, (1999)* Heidelberg, Berlin, New York: Springer-Verlag.
- [Heller et al., 2006] Heller, J., Steiner, C., Hockemeyer, C., & Albert, D.: Competence-Based Knowledge Structures for Personalised Learning, In: *International Journal on E-Learning*, 5(1), (2006), pp. 75-88.
- [Hockemeyer, 2003] Hockemeyer, C.: Competence Based Adaptive E-Learning in Dynamic Domains, In: F. W. Hesse & Y. Tamura (Eds.), *The Joint Workshop of Cognition and Learning through Media-Communication for Advanced E-Learning (JWCL 2003)*, pp. 79-82, Berlin.
- [iClass, 2008] iClass: The iClass research project, <http://www.iclass.info/>
- [Ley, 2006] Ley, T.: *Organizational competency management - A competence performance approach. Methods, empirical findings and practical implications*, Aachen: Shaker
- [Puustinen and Pulkkinen, 2001] Puustinen, M. & Pulkkinen, L.: Models of self-regulated learning: a review, In: *Scandinavian Journal of Educational Research*, 45(3), pp. 269-286.
- [Shneiderman, 1996] Shneiderman, B.: The Eyes Have It: A Task by Data Type Taxonomy for Information Visualizations, In: *Proceedings of the IEEE Symposium on Visual Languages (VL 1996)*, pp. 336-343.
- [Zimmerman, 2002] Zimmerman, B.J.: Becoming a Self-regulated Learner: An Overview, In: *Theory into Practice*, 41(2), (2002), Springer-Verlag.

## **Story Management Technologies for Organizational Learning**

**Andrew S. Gordon**

(University of Southern California, Los Angeles, CA, USA  
gordon@ict.usc.edu)

**Abstract:** The stories told among members of an organization are an effective instrument for knowledge socialization, the sharing of experiences through social mechanisms. However, the utility of stories for organizational learning is limited due to the difficulties in acquiring stories that are relevant to the practices of an organization, identifying the learning goals that these stories serve, and delivering these stories to the right people and the right time in a manner that best facilitates learning. In this paper we outline a vision for story-based organizational learning in the future, and describe three areas where intelligent technologies can be applied to automate story management practices in support of organizational learning. First, we describe automated story capture technologies that identify narratives of people's experiences within the context of a larger discourse. Second, we describe automated retrieval technologies that identify stories that are relevant to specific educational needs. Third, we describe how stories can be transformed into effective story-based learning environments with minimal development costs.

**Keywords:** Storytelling, Knowledge acquisition, Natural language processing, Information storage and retrieval, Simulation-based learning environments

**Categories:** M.0, I.2.7, H.3.3, L.5.1

### **1 Story-Based Organizational Learning in the Future**

Imagine that you, several years from now, are far from home conducting some business for your organization. Perhaps you are a businessman negotiating a new contract with a company in your supply chain, or perhaps you are an international aid worker trying to establish a clean water supply in an impoverished region. The work is gruelling, but is always interesting. The rapid pace of change brings you new experiences that you never expected when you first trained for this job, constantly forcing you to improve your skills in new areas. Keeping in touch with your colleagues back home is a priority for you. Each night, when both time zones are reasonable, you use your smart-phone to socialize with others in your organization - to tell them about the bizarre event that happened to you that day, or simply to hear the latest office gossip.

As usual after a long phone call, your smart-phone has some questions for you. In listening to the conversation you were having, it noticed that you told some new stories - different in some way than the sort of stories that it has heard from you in the past. It plays back some of the audio of these stories for your review. Listening to yourself tell them, you find that many of these stories are narratives of the personal encounters you have had on your journeys. However, some of them are specifically about the job you are there to do, ones that you would be happy to share more broadly

with the rest of the people in your organization. After sorting out which is which with your smart-phone, and re-recording the ones that could benefit from a better delivery, you authorize it to pass along the organizational stories into the story management pipeline.

Contributing in this way to your organization's story management pipeline is a bit more work for you to do, but you can see the value of it each morning as you open your laptop to prepare for the day's new challenges. For this job, preparation requires practice, so you spend an hour each morning honing your skills with a simulation-based training application. Each morning you are faced with new simulated situations that challenge your abilities, perhaps ones that present you with new problems for negotiating your supply chain contract or ones that introduce new considerations for laying out fresh water filtration systems. After completing each new simulation scenario, you always check to see what real-world story was used as the basis for the fictional situation. What was the lesson learned from real-world experience that made its way into the training application you are using this morning? Usually these scenarios are based on the experiences of people you know from your organization, often told into their smart-phones only days or weeks earlier - just like you had done the night before.

## 2 Story-Based Organizational Learning in the Present

Many aspects of this vision of story-based organizational learning in the future, where real-world experiences are captured and transformed into fictional simulation-based learning environments, are already exhibited in the way that some organizations develop new training technologies. In their work to develop immersive training applications for the United States Army, the Institute for Creative Technologies at the University of Southern California has created a number of prototypes that transform the real-world experiences of U.S. Army soldiers into fictional video and virtual-reality training applications. In the Army Excellence in Leadership project [Hill, 04], real-world stories told by junior U.S. Army officers are fictionalized into Hollywood-style movies, then embedded in a leadership training application that allows trainees to interactively interview characters from the films. In the ICT Leaders project [Gordon, 04], real-world stories collected from U.S. Army captains are translated into decision points in a fictional branching storyline, allowing trainees to practice leadership skills by making decisions through conversations with virtual characters in a game-based simulation. ELECT BiLAT [Hill, 06] is a game-based simulation for soldiers to practice conducting bilateral engagements by negotiating with virtual characters, where scenarios are based on the experiences told to developers during interviews with subject-matter experts.

Although each of these examples targets different training objectives and utilizes different delivery methods, each follows a similar philosophy toward the role of stories in organizational learning. In this context, stories are defined as a genre of discourse where the speaker provides a narrative description and interpretation of causally-related past events. The real-world experiences of members of the U.S. Army, told as stories, are used as the basis for fictional scenarios to be experienced by trainees in multimedia learning environments. As such, these projects might be characterized as an *extremely mediated* form of traditional storytelling, where the

lessons learned from the original experience are painstakingly transformed into products that can most effectively deliver these lessons to their target audience.

Unfortunately, all of this mediation comes at a price, both in terms of time and money. These projects, each of which required millions of U.S. dollars and years of effort by large development teams, cannot be endlessly replicated to process all of the stories told by members of an organization, even wealthy organizations that are only a fraction of the size of the U.S. Army. In accordance with the original intent of their development, these systems are extremely effective at delivering a modest number of lessons-learned for a modest number of training objectives. However, they do not represent a general knowledge management solution for story-based organizational learning, where the time between real-world experience and the training of others in the organization needs to be nearly instantaneous, with negligible costs.

In 2004 we began the Story Representation and Management project, a new research effort at the Institute for Creative Technologies at the University of Southern California to develop intelligent technologies for automating the labor required to create multimedia learning environments based on the real-world stories told by members of an organization. We focused specifically on three areas that required the greatest amount of time and effort in the development of the U.S. Army training applications mentioned above. First, *story capture* technologies were developed to automatically identify stories in discourse, obviating the need to collect these stories from practitioners through directed interviews. Second, *story retrieval* technologies were developed to automatically locate stories in a corpus that are directly relevant to particular learning objectives. Third, new designs for *interactive story-based learning environments* were explored, aimed at minimizing the costs of developing effective computer based training. Collectively, these technologies constitute a *story management pipeline*, and represent the first steps toward the realization of the vision of story-based organizational learning described in section 1. Our efforts in each of these areas are described in the next three sections.

### 3 Technologies for Story Capture

The primary methods that are currently used to gather stories for use in organizational knowledge management and training applications involve face-to-face interviews with subject-matter experts, e.g. as part of a cognitive task analysis [Clark, 07], in small group meetings [Snowden, 00], or with directed story-elicitation interviews [Gordon, 05a]. The facilitator/interviewer that participates in these methods is typically not a member of the organization, and their primary role is to ensure that a large number of stories are communicated and recorded that are relevant to specific knowledge management or training needs of the organization during the course of the interview. However, studies of casual storytelling in workplace environments have shown that stories relevant to the organization are common in everyday, non-facilitated conversations among co-workers [Coopman, 98]. If these stories could be captured directly from conversations among co-workers in an automated manner, then the costs associated with collecting stories relevant to organizational practices could be dramatically reduced. Although there are substantial privacy and user-interface challenges associated with extracting stories from conversations among co-workers, our research efforts in this area were specifically focused on technical feasibility.

In our first attempt in this area, we explored the use of machine-learning techniques for identifying stories in segments of conversational speech, using the words recognized with commercial speech-recognition software [Gordon, 05b]. We followed a traditional text classification approach, where a corpus of transcribed conversational speech was first hand-annotated (story / non-story) for use as training and testing data. By developing a clear definition of what counted as a story, our annotators were able to achieve reasonably high inter-rater agreement. Segments of training data were then encoded as high-dimensional feature vectors (word-level unigram and bigram frequency counts) and used to train a naïve Bayes binary classifier. To apply this classifier to test data, overlapping consecutive segments of test data were individually assigned to either the story or non-story class, with confidence values smoothed across segments using a simple mean-average smoothing function. Performance evaluations of our approach yielded low precision (39.6%) and low recall (25.3%), equal to random chance performance on this task. However, we observed substantially higher performance when using transcribed test data (as opposed to the output of a speech recognition system), with reasonable precision (53.0%) and recall (62.9%) scores. We concluded that significant advances in open-domain continuous speech recognition would be required in order to construct a usable story-capture system for casual conversations.

Given the low performance of story capture from speech data we decided to shift our focus to written electronic discourse, specifically weblogs. By randomly sampling weblog entries on the Internet, we found that between 14% and 17% of the text in weblog entries consisted of stories, i.e. narrative descriptions and interpretations of the author's past experiences [Gordon, 07]. To apply our existing story extraction technology to Internet weblog entries, we created a new hand-annotated (story / non-story) corpus of weblog entries for use as training and test data, and achieved reasonable performance levels (precision = 30.2%, recall = 80.9%, F-score = 0.414). By incorporating techniques for automatically detecting sentence boundaries in the test data, utilizing a contemporary support-vector machine learning algorithm, and using a Gaussian function to smooth the confidence values, we were able to significantly improve the overall performance of this approach (precision = 46.4%, recall = 60.6%, F-score = 0.509). Although these performance levels leave some room for improvement, we believe that it is high enough to explore the integration of automated story capture technologies in productivity software applications used by organizations (including email, online forums, and general-purpose word processing).

#### 4 Technologies for Story Retrieval

The second key challenge in automating the management of organizational stories is connecting people who have specific learning needs with the stories that are most relevant to these needs. This problem does not arise when a modest number of stories are collected through directed interviews as part of the development of specific training applications, where the learning objectives are known ahead of time. However, as the size of organizational story collections becomes very large, and where these stories may have relevance to unanticipated learning needs, it is critical to have some mechanism for automatically pairing available stories with new learning objectives. Previous work on this problem has focused on story *indexing* (e.g.

[Domeshek, 92] [Johnson, 00]) where human analysts identify the specific points that are made by a story, and encode these points using formal representation to facilitate their retrieval. Point-based indexing of this sort is particularly suited for cross-domain retrieval, e.g. where a story about conducting contract negotiations with a company in a supply chain illustrates a point that is directly relevant to establishing a clean water supply in an impoverished region. In our own work, we have not pursued this style of point-based indexing. Aside from the difficulties in automating approach, cross-domain stories have not proven to be particularly useful in the development of the training applications mentioned earlier in section 2. Instead, we have seen that the stories most relevant to a learning need are within the same task domain or activity, e.g. the stories that are most useful for learning how to conduct contract negotiations are about the task of conducting contract negotiations. The technical challenge is to automatically select stories that describe experiences in the context of task or activity.

Our approach to this automation challenge was to use techniques for textual information retrieval, where textual descriptions of activities or tasks are used as queries for the retrieval of textual stories from a collection. To explore the feasibility of this approach, we constructed a large-scale retrieval system for finding stories automatically extracted from Internet weblogs [Gordon, 08]. In this system, called StoryUpgrade, users described an activity as a paragraph-sized description of events expected to occur in the task, written as a past-tense first-person narrative (a “boring story” of the activity). The system then encoded the query as a weighted vector of lexical features, and then ordered the relevance of stories in the collection using vector-based similarity measures. Two versions of this system were built that differed in the way that they collected stories from Internet weblogs. In the first version, we created a single collection of stories by applying our story capture technology (described earlier in section 3) to 3.4 million weblog entries, yielding a text corpus of over one billion words. In the second version, we constructed specialized story collections for each query by first sending fragments of the activity description to a commercial weblog search engine, and then applying our story capture technology to hundreds or thousands of the top search results.

We evaluated the effectiveness of the StoryUpgrade system (version 1) as a tool for finding stories relevant to the development of simulation-based training applications. The Intelligent Convoy Operations Support (ICOS) project at the University of Southern California’s Institute for Creative Technologies was an effort to develop a tutoring module to augment a training simulation for military convoy operations. Four members of the ICOS project team used the StoryUpgrade system to find relevant stories about military convoy operations told in Internet weblogs. In one forty-five minute session, these participants authored five activity descriptions of the convoy operations task and judged the relevance of 67 retrieved weblogs. There were 23 relevant stories, 6 relevant non-stories, 14 non-relevant stories, and 24 non-relevant non-stories (55% story precision, 43% relevance precision). We concluded that the performance of our approach to pairing task descriptions to stories in the collection was not high enough to fully automate this process, but that a developer could efficiently use this technology to find a sufficient number of task-relevant stories in very large collections in less than an hour.

## 5 Interactive Story-Based Learning Environments

Contemporary computer-based education and training systems are effective to the degree in which they can incorporate four complimentary design characteristics. Systems should support *situated learning* by presenting learners with situations that mirror the contexts in which their acquired skills will be executed. The acquisition of these skills is more effective when learners are given one-on-one *guided instruction* from an experienced tutor. *Multimedia* presentation can help people learn certain types of information, particularly when they encourage dual coding of the information, when the media support one another, and when learners have low prior knowledge or aptitude for the subject matter. Finally, educational experiences should be set in a rich *narrative environment*, supporting the learner's retention of educational experiences as remembered stories. The adoption of these four design characteristics has become nearly universal in the development of immersive learning environments, as in each of the systems described earlier in section 2. Unfortunately, the development costs (time and money) of these systems are also universally enormous, typically including the labor of computer programmers, scriptwriters, 3D graphic artists, animators, voice talent, and sound engineers. In our own research, we explored the opposite extreme of this design space: what is the minimal-cost design for computer-based education that supports situated learning and guided instruction in a multimedia narrative environment?

Our design solution is a web-based application called Fourth Frame Forums, which combines traditional four-frame comic strips with online web-based discussion forums [Gordon, 06]. In this application, users are presented with a four-frame comic strip that depicts a fictional problem scenario, where the protagonist is faced with a decision. The last dialogue balloon in the comic, where the protagonist decides what to say to resolve the problem, is left blank. By typing a statement directly into this dialogue balloon, the user creates a new discussion thread in an online forum, where the user's dialogue choice can be critiqued and discussed by other users of the forum, guided by an experienced mentor that moderates this discussion.

The central innovation of the Fourth Frame Forums application is the authoring methodology, which is designed to allow a training developer or instructor to quickly create new Fourth Frame Forum scenarios based on non-fiction stories of real-world experiences gathered from practitioners in the organization. The approach mirrors the techniques developed for authoring branching storylines for training applications [Gordon, 04], where stories are analyzed to identify the specific expectations about the task that they violate (the reason they are surprising and interesting). These expectations are then used to craft a fictional situation where a decision is to be made by the user, and where their choice will be dependent on whether or not they believe the expectations that were violated in the real-world story.

As part of our original work on the Fourth Frame Forums application, we created a series of fictional scenarios based on real-world stories involving leadership as told by U.S. Army Captains interviewed for the Army Excellence in Leadership project [Hill, 04]. To visualize these scenarios as four-panel comic strips, we gathered a number of screen captures from the game-based virtual-reality environment used in the ICT Leaders project [Gordon, 04], and used a standard graphical illustration application to arrange these screen captures into the four-frame comic format with the



appropriate dialogue balloons and narration boxes. As a more general solution for visualizing scenarios relevant to a broader set of tasks and organizations, we have found that contemporary “life simulation” computer games (e.g. *The Sims*, by Electronic Arts) provide an ample array tools for quickly creating scenes of customized characters in custom environments, and for exporting screen captures of these scenes for use in new Fourth Frame Forum episodes. Figure 1 shows a proof-of-concept comic authored in a couple of hours using this approach.



Figure 1: A Fourth Frame Forum visualized using scenes from a computer game

## 6 Conclusions

Achieving the vision of fully automated story management for organizational learning presented in section 1 will require overcoming many remaining technical challenges. However, there are key processes that can be automated to lessen the development costs of story-based learning environments, making them practical as an *extremely mediated* form of organizational storytelling. In this paper, we described research efforts to develop three complimentary story-management technologies for reducing the costs associated with collecting organizational stories, retrieving stories relevant to organizational learning needs, and transforming these stories into computer-based education that supports situated learning and guided instruction in a multimedia narrative environment. There remains a need for technology that can automatically capture stories from conversational speech, but we have demonstrated that stories can be extracted from extremely large text corpora with reasonable accuracy. Likewise, we have shown that finding relevant stories can be viewed as a text retrieval task using activity-based queries, but these techniques are not applicable to non-textual story collections and do not service retrieval needs based on the specific points of stories in the collection. Finally, Fourth Frame Forums offer an extremely low-cost solution for authoring story-based learning environments, but still requires the effort of a training developer or instructor. Collectively, these technologies allow a single training developer, over the course of a single day, to search through stories collected from the weblogs of members of an organization, identify ones that are relevant to specific organizational tasks, and author (and deliver) an effective story-based learning environment for immediate use throughout the organization.

### Acknowledgements

The project or effort described here has been sponsored by the U.S. Army Research, Development, and Engineering Command (RDECOM). Statements and opinions expressed do not necessarily reflect the position or the policy of the United States Government, and no official endorsement should be inferred.

### References

- [Clark, 07] Clark, R., Feldon, D., vanMerriënboer, J., Yates, K., Early, S.: Cognitive Task Analysis. In Spector, J., Merrill, M., van Merriënboer, J., & Driscoll, M. (Eds.) Handbook of research on educational communications and technology (3rd ed.). Mahwah, NJ: Lawrence Erlbaum Associates, 2007.
- [Coopman, 98] Coopman, S. & Meidlinger, K.: Interpersonal Stories Told by a Catholic Parish Staff. *American Communication Journal* 1(3), 1998.
- [Domeshek, 92] Domeshek, E.: Do the Right Thing: A Component Theory for Indexing Stories as Social Advice. PhD Thesis, Yale University, 1992.
- [Gordon, 04] Gordon, A.: Authoring Branching Storylines for Training Applications. 6th International Conference of the Learning Science, Santa Monica, CA, June 22-26, 2004.
- [Gordon, 05a] Gordon, A.: The Fictionalization of Lessons Learned. Guest Editorial for Media Impact Column, *IEEE Multimedia* 12(4):12-14. 2005.
- [Gordon, 05b] Gordon, A. & Ganesan, K.: Automated Story Extraction From Conversational Speech. 3rd Intl. Conference on Knowledge Capture, October 2-5, 2005, Banff, AB.
- [Gordon, 06] Gordon, A. (2006) Fourth Frame Forums: Interactive Comics for Collaborative Learning. 14th ACM Intl. Conference on Multimedia, October 23-27, 2006, Santa Barbara, CA.
- [Gordon, 07] Gordon, A., Cao, Q., & Swanson, R.: Automated Story Capture From Internet Weblogs. 4th Intl. Conference on Knowledge Capture, October 28-31, 2007, Whistler, BC.
- [Gordon, 08] Gordon, A. & Swanson, R.: StoryUpgrade: Finding Stories in Internet Weblogs. International Conference on Weblogs and Social Media, March 31-April 2, 2008, Seattle, WA.
- [Hill, 04] Hill, R., Gordon, A., and Kim, J.: Learning the lessons of leadership experience: Tools for interactive case method analysis. 24th Army Science Conference, Orlando, FL, 2004.
- [Hill, 06] Hill, R., Belanich, J., Lane, H., Core, M., Dixon, M., Forbell, E., Kim, J., Hart, J.: Pedagogically structured game-based training: Development of the ELECT BiLAT simulation. Proceedings of the 25th Army Science Conference, 2006.
- [Johnson, 00] Johnson, C., Birnbaum, L., Bareiss, R., Hinrichs, T.: War stories: harnessing organizational memories to support task performance. *Intelligence* 11(1): 16-31. 2000.
- [Snowden, 00] Snowden, D.: The art and science of Story or 'Are you sitting uncomfortably?': Part 1: Gathering and harvesting the raw material. *Business Information Review*, 17:147-56, 2000.

## **Learner-Generated Annotation of Learning Resources – Lessons from Experiments on Tagging**

**Steffen Lohmann**

(University of Duisburg-Essen, Germany  
steffen.lohmann@uni-duisburg-essen.de)

**Stefan Thalmann**

(University of Innsbruck, Austria  
stefan.thalmann@uibk.ac.at)

**Andreas Harrer**

(Catholic University of Eichstätt-Ingolstadt, Germany  
andreas.harrer@ku-eichstaett.de)

**Ronald Maier**

(University of Innsbruck, Austria  
ronald.maier@uibk.ac.at)

**Abstract:** The importance of comprehensive annotations for learning resources is widely recognized. However, it is often unclear how these annotations should be created. A promising solution might be that learners annotate learning resources during execution of learning processes. This paper examines tagging as a learner-driven approach that can be used to get annotations on a collaborative level. The characteristics of learner-generated annotations in learning scenarios and the applicability of these annotations to describe learning resources are investigated. As empirical grounding, the results of three independent experiments are presented in order to inform decisions concerning the establishment of institutionalized settings deploying tagging approaches.

**Keywords:** annotation, learning resources, tagging, metadata, collaboration

**Categories:** L6.2, L6.1, L3.6, L3.5, L1.2

### **1 Introduction**

Adding metadata to learning resources is a prerequisite for sophisticated administration, exchange, and reusability of these resources. Even though benefits and requirements of metadata are well-described and formulated in standards such as IEEE LOM sufficient annotations are still not provided in many cases [Brooks and McCalla 2006]. Often, no organizational routines or responsibilities are defined. Authors of learning resources are not willing to spend additional effort to add metadata and professional metadata authors are too expensive. With the advent of Web technologies allowing large numbers of users to participate in content production, collaborative ways to annotate Web resources, such as tagging, become

popular. The application of learner-generated annotation could be a promising solution to get suitable descriptions of learning resources.

In this paper we examine the applicability of tagging as a form of learner-generated annotation of learning resources. We first give a brief overview on different ways of annotating learning resources in Section 2. In Section 3, we report on studies we conducted to investigate this phenomenon. Subsequently, we draw conclusions in Section 4 based on our insights gained in the studies. The paper ends with an outlook on future research and development tasks with respect to this topic.

## 2 Annotation of Learning Resources

Annotation of resources has a long history in librarianship and was taken over to digital resources. Traditionally, a small group of experts categorizes or indexes resources on the basis of an agreed, structured catalogue of keywords, a taxonomy, in order to make resources accessible [McGregor and McCulloch 2006]. With the rapidly increasing amount of digital resources, time and cost required for professional metadata creation are unsustainable for many organizations. As a consequence, resources are frequently not or only partially annotated and descriptions often do not fit the users' needs.

Automatic processes can resolve this problem in part by reducing the number of metadata elements that have to be manually edited [Duval and Hodgins 2004], thus relieving the metadata author from part of the tedious work of filling in metadata forms [Cardinaels et al. 2005]. The basic idea of automatic annotation of resources is to use (1) different sources available to the authoring system, (2) the resource itself or (3) the context in which the resource is used [Motelet et al. 2006]. Automatic metadata generation offers good results for technical descriptions such as size or format but is no feasible approach for more qualitative descriptions, like summarizing keywords or level of difficulty [Bauer et al. 2008]. Particularly, if annotations for multimedia content and different usage contexts are required, the exclusive use of automatic approaches is not sufficient, in general, but can be used to support the manual annotation process.

With the advent of new Web concepts under the "Web 2.0" umbrella [O'Reilly 2005], tagging seems to be a promising approach that can be used for annotating learning resources. Thereby, a tag is a freely chosen text-based annotation to a resource that is not restricted to a controlled vocabulary. Collaboratively added tags can be represented in different kinds of structures that have come to be called "folksonomies" [Rollett et al. 2007]. In contrast to the top-down approach of expert annotation, this bottom-up approach reflects the learner perspective on the resources and can thus lead to a broad spectrum of descriptions for learning resources.

A major concern that has been voiced against this solution is that untrained people cannot achieve the metadata quality professionally trained staff reaches. However, Surowiecki argues for the superiority of the "wisdom of the crowds" which is conceptualized as "collective intelligence", i.e. the ideas of many people bring in a wider variety compared to one single person [Surowiecki 2004]. Similarly, the theory of the "expert blind spot" [Nathan et al. 2001] poses that the expert's judgement can be oriented towards a focused perspective that is not well connected to the perspectives of the learners, particularly to unconventional perceptions. Specifically

for metadata a broad spectrum of descriptions is valuable because the community of users of learning resources represents the potential seekers as well as several application contexts exist in which learning resources are used. Figure 1 shows the different approaches for generation of annotations schematically.

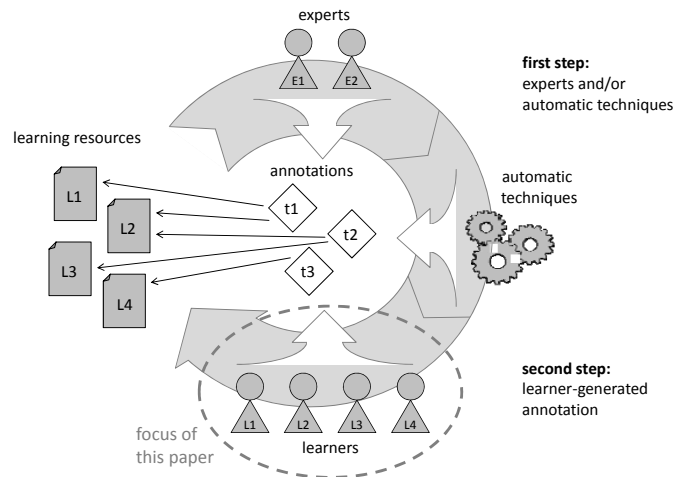

Figure 1: Annotation life-cycle

### 3 Experiments on Tagging of Learning Resources

We conducted studies to investigate the applicability of tagging as an approach to annotate learning resources. In the following, these studies are briefly described.

#### 3.1 Tagging of Lecture Slides in a Pen-and-Paper Study

We investigated the reliability and usefulness of students' tags compared to expert tags for lecture materials in a small-scale experiment. To get a controlled scenario – without technical influences on the question we investigate in – we chose a pen-and-paper design in a classroom setting, where the tagging procedure and the intended navigational feature of shared tags was emulated by circulating learning materials randomly among the students.

The study was conducted as a voluntary experiment in an advanced course on “computer-supported learning and work in groups” with 8 students and 14 exemplary slides taken from selected lectures of the course. Each student was assigned to a specific colored pen so that we can take a look at individual tagging behavior without violating data security. The slides were directly annotated resulting in 286 student tags of which 123 were different. In our analysis, we compared the collection of student tags with the tags given independently by an expert in the field, the lecturer of the course (and author of the study). The expert tag set was comprised of 74 tags of which 70 were different (the other 4 were more abstract concepts characterizing multiple slides). Based on this material, we elaborated on three research questions:

1. *“Expert’s Recall”*: Which slides can be found by a simulated query with the expert tags on the complete set of learner tags and which relevance (number of matching tags) does it have? With respect to this question, we found that in the 14 simulated queries (the expert tag set for each slide against the whole tag set of learners) all relevant slides could be found; the ratio of matches was in average 66% of the expert tags also assigned to a slide by the students.
2. *“Learner’s Recall”*: Which slides can be found by a simulated learner query on the set of expert tags and which relevance does it have? The result was that 95 of 100 simulated queries with the student tags got the relevant slide as a match. Interestingly, the only missed queries had all the same slide as focus, where the expert had given just 2 tags, which resulted in only 2 out of 7 of the students that tagged this slide finding a match.
3. *Abstraction / keyword ratio*: How many keywords assigned as tags are already present as text in the slides? This question addresses if the tags given to the learning resources stay close to the original resource or if abstraction and aggregation processes are performed by the tagger. The ratio between tags present as keywords in the slides (excluding the problematic slide mentioned above) and all tags given is 86% for the expert (62/72) and 94% (234/250) for the students. While the results do not allow reliable claims, a hypothesis for further research could be to check if experts tend to tag more abstractly and conceptual, thus having a smaller keyword ratio.

Combining the results on questions 1 and 2, we consider the correspondence of the student-generated tags and the expert tags as a good fit, in contrast to the results given in a similar study in [Bateman et al. 2007]. Yet, there are several differences in the studies, such as a synchronous vs. asynchronous setting, voluntary vs. obligation to participate. Question 3 goes along a cognitive perspective to explore the conceptual understanding and ability for abstraction while tagging, i.e. how strong the tendency is to cling to the exact words contained in the resource when choosing tag names.

### 3.2 Tagging of Learning Resources via an Online Questionnaire

Next to the pen-and-paper study, a multi-round lab experiment was realized within a course on introduction to information systems. Altogether, 174 Bachelor students of business and economics participated. The experiment was realized in two experimental series with seven course groups of between 20 and 28 students each. Every student was asked to tag 10 digital learning resources (2 videos, 3 presentation slides, 3 screenshots and 2 pictures). Overall, 4246 tags (404 different tags) were assigned to the 10 resources. As common in many available tagging tools, the most frequently used tags were presented and could be chosen easily. Also, additional tags could be entered. Technically, the study was realized by a questionnaire tool. Typical linguistic errors such as wrongly written tags and confusion by plural/singular forms were cleaned by the researchers. A more detailed description of the study can be found in [Bauer et. al. 2008].

The aim of the experiment was to investigate the applicability of tagging to gain suitable descriptions of learning resources. In order to achieve this, three premises were formulated and tested in the experiment:

4. *Commitment: Which tags are generally accepted and which tags are specialized and individual?* To apply tagging in organizations and to use learner-generated descriptions a set of meaningful tags must be extracted. Therefore, a reliable separation of generally accepted tags from specialized tags has to be achieved. The results of the experiment show that this separation seems to be realizable. In the experiment a 5% criteria could be applied to extract the meaningful tags suitable for describing resources on an institutional level. The statistical distribution shows a power law curve.
5. *Convergence: Is there a stable set of frequently used tags and which set of tags is it?* In order to apply criteria for commitment a stable set of tags and thus convergence is required. Convergence of tags could not be shown finally but several findings indicate a tendency towards convergence. The number of changes in the top 5 ranking of tags was monotonically decreasing. Additionally, the ratio of distinct tags to number of all tags decreased but the total number of distinct tags increased over all experimental turns. To show a total convergence a very large number of taggers is required. In organizational settings, this large number of taggers is normally not available and thus indicators for sufficient convergence should be identified in further research.
6. *Coordination: Is there an effect of initial tags on the semantic orientation that user-generated tags evolve?* The use of tagging in organizational settings should consider respective conventions and management directives. Therefore, coordination of the 'semantic direction' of descriptions by varying the starting set would be very useful. In order to investigate this aspect we used two different directions of semantic description (context- and content-related descriptions) for the two experimental settings. In the series with start tags describing the content of learning resources, further tags describing the content were entered by the learners. Likewise, in the series with start tags describing the context, further tags describing the context were entered. Overall, the textual input differs between 71% and 93% with 81% on average for the same resources over both experimental series. This means that on average 81% of the tags were different between the series. The 19% tags that were identical on average were mainly words that occur in the resource itself, such as headlines. These observations support the proposition on coordination, i.e. the formation of the starting set of tags can indeed influence the semantic direction of the metadata descriptions.

Altogether, in this lab experiment the extraction of meaningful descriptions by applying a 5% criteria and the coordination of tagging behavior by changing the initial set of tags could be shown. Indicators suggest a trend towards convergence in larger user groups.

### 3.3 Using Tagging Systems in University Courses

In addition to the two controlled experimental settings, we applied tagging systems in field studies over a longer period to support blended learning in university courses. The general aim of this research was to discover commonalities and differences between application of tagging in open Web and focused learning contexts.

In one scenario we used the social bookmarking service *del.icio.us* in a student project with 22 participants. The students were asked to register for this service and use it to bookmark Web pages that they consider relevant to the project context. In each case, the students should use a predefined ‘project tag’ in addition to their freely chosen tags. That way, it was possible to view the entire collection of annotated Web pages simply by inputting this ‘project tag’.

In another scenario, a Web-based application prototype has been implemented that enables the students to tag lecture slides during the teaching process or afterwards. The students attending the lecture were enabled to organize the slides from their personal perspective or to use the group view to explore the slides via the aggregated tags of the learning community. A more detailed description of the developed application prototype can be found in [Fienhold et al. 2007].

In both cases we provide an initial set of tags as starting point and illustration. With respect to the findings of research question 6 (see Section 3.2), we thereby guide the annotation in a certain ‘semantic direction’, in this case, towards content-related descriptions. Two research questions were of particular interest in these field studies:

7. *Participation: How many learners use the tagging system actively and how many passively?* Since participation was not mandatory or extrinsically motivated in both settings, similar to open Web contexts only a small number of the students actively used the tagging feature whereas the larger part can be regarded as what is called “lurkers” [Nielsen 2006] – they did not actively contribute but read the contributions of others. In the first case, 5 of 22 participants bookmarked 19 Web pages in addition to the Web pages that have already been bookmarked in advance. In the second case, 20 students used the tagging system to access the lecture slides, but only 4 students actively participated in the tagging process.
8. *Acceptance: Do learners appreciate the possibility to tag resources and to access learning contents via tags?* All students that used the tagging systems give positive feedback on this additional way to annotate or access learning resources. Most students find the feature to explore learning contents by navigating tags particularly useful. In the case of *del.icio.us*, some students even use tags to discover further web pages that have not been bookmarked by the project members but by other *del.icio.us* users. The initially given tag set was regarded as a helpful starting point and illustration. However, in the second scenario, most students prefer to annotate the lecture slides with pen and paper as usual.

Overall, in these focused field studies the basic user behavior and observed effects were similar to what is known from open web contexts. The additional form of accessing learning resources via learner-generated annotations was generally appreciated, but active participation in tag generation was limited though.

## 4 Conclusions

Generalizing from our studies with different research foci in a multi-case approach [Stake 2005] we gained several indicators that learner-generated annotation of learning resources can be a valuable contribution for all parties involved in the learning process, i.e. the learner her-/himself, peer learners, lecturers, and institutions.



Though our results are first indicators from university settings, similar effects can be expected in other organizational contexts. In the following, the results are systematized as theses for the design of institutionalized settings deploying tagging in businesses and organizations:

**Use stable set of tags for agreed description of resources:** Based on our results on establishment of generalized tags (question 4), tag convergence (question 5), and the matching of learner and expert tags (questions 1 & 2) we observe a tendency towards a stable set of tags that helps to index and easily find the relevant learning resources. Furthermore, this stable set could be used to gain valuable metadata.

**Guide the tagging process:** Besides the emergence of tags from a learning community, the addition of expert tags can contribute to the activation of the tagging process. By giving an initial description of learning resources, guidance in a certain direction can be realized (questions 6 & 8), which could be useful for maintaining organizational guidelines and principles.

**Use text extracted from resources for starting set of tags:** Furthermore, learners tend to use prominent words occurring in the learning resource, like headlines or bold text, as tags in many cases (questions 3 & 6). As a consequence, automatic approaches could be used to extract these words and use them as a starting point for the tagging process.

**Use small set of selectable tags to support convergence:** In addition to these initial sets, selectable tags could facilitate the convergence and thus the commitment within a group. This orientation can be specifically given by an expert, as the results on the coordination aspect (question 6) show, which could be used by a teacher productively to steer the tagging process and choice of tag words along the line of orientation that is best in tune with the lecture.

Motivating learners to participate, the need for electronically provided learning material, and integration into the existing ICT infrastructure are challenges in this topic area. A further challenge of learner-generated annotation is the high probability of noise in the tags [McGregor and McCulloch 2006]. For using tagging over a longer period of time, institutional life-cycles and procedures for cleaning and consolidation of tag sets are required.

## 5 Further Research

Further research includes deeper investigation and better understanding of the interplay and mutual enhancement of automatic, expert, and learner annotation. As already illustrated in Figure 1, an evolutionary process that combines these three types of annotation appears to be promising. First steps in this direction can be found in [Dahl and Vossen 2008].

Furthermore, organizational routines and processes for tagging should be investigated in order to enable an efficient management of these descriptions, including life-cycles that ensure quality. Since seamless integration of annotation into existing ICT infrastructures is crucial for the success of learner-generated annotation, further research and experiences regarding design and success factors are desirable.

Another promising research topic is the processing and utilization of the learner-generated annotations. On the one hand, sophisticated visualizations (apart from tag clouds) can provide multidimensional access and exploration possibilities on the

learning resources by means of graphical navigation through a space representing tags and resources. On the other hand, recommendation features could allow for learner-centered selection and presentation of learning resources. In both cases, all parts of the tripartite model encompassing the learning resources, the learners, and the annotations can be used as a source for relationship discovery.

### Acknowledgements

We are grateful to all our students participating in the studies.

### References

- [Bauer et al. 2008] Bauer, M., Maier, R., Thalmann, S.: "Metadata Generation for Learning Objects – An Experimental Comparison of Automatic and Collaborative Solutions"; MKWI 2008, München, Germany, Springer (2008).
- [Bateman et al. 2007] Bateman, S., Brooks, C.; McCalla, G., Brusilovsky, P.: "Applying Collaborative Tagging to E-Learning"; Proceedings of WWW 2007 Workshop on Tagging and Metadata for Social Information Organization (2007).
- [Brooks and McCalla 2006] Brooks, C.; McCalla, G.: "Towards Flexible Learning Object Metadata"; Int. J. of Continuing Engineering and Lifelong Learning, 16, 1/2 (2006), 50-63.
- [Cardinaels et al. 2005] Cardinaels, K., Meire, M., Duval, E.: "Automatic Metadata Generation: The Simple Indexing Interface"; Proceedings of the International World Wide Web Conference (WWW05), Chiba, Japan, ACM (2005).
- [Dahl and Vossen 2008] Dahl, D., Vossen, G.: "Learning Object Metadata Generation in the Web 2.0 Era"; Int. J. Information Communication and Technology Education, 4, 3 (2008).
- [Duval and Hodgins 2004] Duval, E., Hodgins, W.: "Metadata Matters"; International Conference on Dublin Core and Metadata Applications, Shanghai (2004).
- [Fienhold et al. 2007] Fienhold, J.; Riechert, T.; Lohmann, S.: "Der Lecture Tagger: Social Tagging in E-Learning-Umgebungen"; Proceedings of the Workshop on e-Learning 2007, HTWK, Leipzig (2007), 251-261.
- [McGregor and McCulloch 2006] McGregor, G., McCulloch, E.: "Collaborative Tagging as a Knowledge Organisation and Resource Discovery Tool"; Library Review, 55, 5 (2006), 291-300.
- [Motelet et al. 2006] Motelet, O., Baloian, N., Pino, J. A.: "Learning Object Metadata and Automatic Processes: Issues and Perspectives", Informing Science Press (2006).
- [Nathan et al. 2001] Nathan, M., Koedinger, K.R., Alibali, M.: "Expert Blind Spot: When Content Knowledge Eclipses Pedagogical Content Knowledge"; Paper presented at the Annual Meeting of the American Educational Research Association (AERA), Seattle (2001).
- [Nielsen 2006] Nielsen, J.: "Participation Inequality: Encouraging More Users to Contribute"; [http://www.useit.com/alertbox/participation\\_inequality.html](http://www.useit.com/alertbox/participation_inequality.html) (last access April 14th, 2008).
- [O'Reilly 2005] O'Reilly, T.: "What is Web 2.0. Design Patterns and Business Models for the Next Generation of Software"; <http://www.oreillynet.com/pub/a/oreilly/tim/news/2005/09/30/what-is-web-20.html> (last access April 14th, 2008).

[Rollett 2007] Rollett, H., Lux, M., Strohmaier, M., Dösinger, G., Tochtermann, K.: "The Web 2.0 Way of Learning with Technologies"; *Int. J. of Learning Technology* 3, 1 (2007), 87-107

[Stake 2005] Stake, R.E.: "Multi Case Study Analysis"; New York: The Guildford Press (2005)

[Surowiecki 2004] Surowiecki, J.: "The Wisdom of Crowds: Why the Many are Smarter than the Few and How Collective Wisdom Shapes Business, Economies, Societies and Nations"; B&T Press (2004)

**Special Track on Knowledge Visualisation and  
Knowledge Relationship Discovery  
KVD 2008**

**Michael Granitzer**

(Know-Center Graz, Austria,  
mgrani@know-center.at)

**Vedran Sabol**

(Know-Center Graz, Austria,  
vsabol@know-center.at)

**Wolfgang Kienreich**

(Know-Center Graz, Austria,  
wkien@know-center.at)

**Horst Bischof**

(Graz University of Technology, Austria,  
bischof@icg.tugraz.at)

Many researchers in the field of Knowledge Discovery and Knowledge Visualisation are aware of the indicators on information growth provided in the study “How Much Information 2003” conducted by the University of California at Berkeley. In early 2007, a new study conducted by IDC2 provided new numbers on information growth for 2006 and estimates for 2010. The conclusions of this study, which appropriately was titled “The Expanding Digital Universe”, are easily summarized: The amount of digital information surrounding us continues to grow exponentially.

KVD aims at providing a platform for researchers exploring knowledge contained in this expanding digital universe and trying to anticipate its explosion. This year’s special track is the sixth event in a series which started with KIV (Knowledge and Information Visualisation) at I-KNOW’03 and which was extended and renamed to KVD beginning with I-KNOW’06.

The 2008 special track on Knowledge Visualization and Knowledge Relationship Discovery (KVD’08) addresses recent developments in fields of knowledge and information visualization, knowledge discovery and information retrieval, involving discovery, visual presentation of and interaction with abstract knowledge, information spaces and structures to facilitate their rapid assimilation and understanding. Special emphasis is placed on the identification and analysis of relationships between knowledge items rather than knowledge items themselves.

An international program committee has selected a total of six contributions for publication and presentation at KVD 2008. The topics covered by the contributions reflect the multidisciplinary character of the special track. Sabrina Bresciani and Martin J. Eppler analyzed how the effects of visualizations on experience sharing and retention in groups can be measured. Ivona Dudek and Jean-Yves Blaise investigated

methods for the visual assessment of heritage architectural lifecycles. Tatiana Tekušová, Viktor Voss and Jörn Kohlhammer applied semantic search and visualization to time-series data. Olaf Noppens and Thorsten Liebig tried to foster understanding of interlinked data through visualization, exploration and analysis of ontologies. Philipp Heim and Jürgen Ziegler investigated ways to handle the complexity of RDF data by combining list and graph visualization. Benno Stein and Sven Meyer Zu Eissen devised a solution for the Spock data mining challenge they called Weighted Experts.

The presentation of the accepted peer-reviewed contributions will be complemented by an invited talk about „Discovering incoherences in Web-Archive/ing“ given by Dr. Marc Spaniol, who has accepted our invitation to present aspects of his work at the Max Planck Institute for Computer Science in Saarbrücken, where he is a member of the Database and Information Systems group lead by Prof. Weikum.

The organizers would like to thank the members of the program committee, whose scientific expertise and qualified judgements have made it possible to retain the high quality standards of the KVD special track series. The organizers would also like to thank all contributors, whose valuable input has provided a multidisciplinary view on recent developments in the field of Knowledge Visualisation and Knowledge Relationship Discovery.

## **Organizers**

- Horst Bischof, University of Technology Graz (Austria)
- Michael Granitzer, Know-Center Graz (Austria)
- Wolfgang Kienreich, Know-Center Graz (Austria)
- Vedran Sabol, Know-Center Graz (Austria)

## **Program Committee**

- Maria Bannert, TU Chemnitz, Germany
- Maik Anderka, Universität Weimar
- Albert Bifet, University of Catalunya
- Jean-Yves Blaise, UMR CNRS/MCC MAP 694 gamsau, Marseille
- Remo Burkhard, ETH Zürich
- Yiwei Cao, RWTH Aachen
- Richard Chbeir, University of Bourgogne
- Arnaud da Costa, University of Bourgogne
- Mario Döller, Universität Passau
- Anna Glukhova, RWTH Aachen
- Helmut Grabner, Technische Universität Graz
- Katharina Kaiser, TU Wien
- Josef Kolbitsch, Technische Universität Graz
- Nedim Lipka, University of Weimar
- Elisabeth Lex, Know-Center Graz

- Mathias Lux, Alpen-Adria-Universität Klagenfurt
- Sven Meyer zu Eissen, University of Weimar
- Markus Muhr, Know-Center Graz
- Bernhard Nessler, TU Graz
- Marc Spaniol (RWTH Aachen)
- Christin Seifert, Technische Universität Graz
- Benno Stein, Medien Universität Weimar
- Wibke Weber, Hochschule der Medien, Stuttgart

# **Do Visualizations Foster Experience Sharing and Retention in Groups? Towards an Experimental Validation**

**Sabrina Bresciani**

(University of Lugano (USI), Lugano, Switzerland  
sabrina.bresciani@lu.unisi.ch)

**Martin J. Eppler**

(University of Lugano (USI), Lugano, Switzerland  
martin.eppler@lu.unisi.ch)

**Abstract:** In recent years the visualization of knowledge has been gaining wider attention: visualization is said to enhance human capabilities for knowledge intense activities such as decision making and strategic thinking. However, this is a recent field and still widely unexplored. Thus far, the advantages of knowledge visualization have been investigated mainly through anecdotal evidence and qualitative studies. In this paper, we propose an experimental approach to further comprehend the role of visualization in fostering knowledge sharing. We plan to compare the elicitation and evaluation processes of groups who are provided (1) with an optimal visual support, (2) with a sub-optimal visual support, and (3) without any visualization. The goal of our research is to apply the experimental approach – widely used in studying GSS (Group Support System) but seldom used in knowledge management – to shed light on the role of visualization for knowledge-intensive tasks in groups. We report first preliminary results of an experiment with 56 MBA students and also outline the limitations of our approach.

**Keywords:** knowledge visualization, collaborative visualization, Group Support Systems, knowledge work, knowledge sharing

**Categories:** H.4.3, H.5.3, J.5, M.0

## **1 Introduction**

Collaborative knowledge work, such as experience sharing and decision making in meetings, is a crucial task in organizations: the quality of the decision process and outcome can have a dramatic impact on a company's performance. Several scholars have investigated how information visualization can help in strategic thinking, by lowering the cognitive load, providing fast insights and allowing for comparisons [Shneiderman, 96] [Blackwell, 01]. Similarly, the visualization of knowledge can potentially augment the quality of knowledge-intensive tasks such as decision making, sharing knowledge, creating ideas, evaluating and planning [Bitter-Rijkema, 02] [Coffey, 04]. Thus far, this interdisciplinary field is still in an emergent phase [Lai, 08].

With our current research, we aim at understanding how knowledge tasks in teams can be improved by using visual support. We focus on computer-based visualizations, as for example visual metaphors, diagrams, mind maps, matrices, timelines, templates, etc. (see examples in Figure 1). First, we investigate which

characteristics of knowledge visualization can facilitate knowledge work in groups. Second, we plan to compare knowledge sharing and evaluation of groups that have a visual support and groups that have no support other than a flipchart. With our investigation we attempt to provide evidence for the efficacy of visualization for facilitating knowledge intensive tasks such as experience elicitation and sharing. To reach this goal we propose to conduct an experiment with managers, giving them a typical organizational task of sharing strategic experiences and ranking (evaluating) these experiences by importance. We will then compare the results of the groups with a fitting visual support, with a sub-optimal visual support, and with no visual support.

In GSS (Group Support Systems) and DSS (Decision Support Systems) there is a long tradition of experimentation, comparing for example, face to face meetings with distributed meetings, or comparing different kinds of supports [Carey, 97] [Fjermestad, 98] [Briggs, 06] [Reinig, 07]. Conversely, in knowledge management experiments are not an often used method, with few exceptions [Brodbeck, 02]. We aim to bridge the findings and traditions of both fields, by proposing a compound methodology, based firstly on qualitative studies (interviews and observations) that lead to the development of the *collaborative dimensions framework* [Bresciani, 07], and then to an experimental approach.

## 2 Research question and design: investigating collaborative knowledge visualization

The main research question of this study is to investigate if visualization improves experience elicitation, sharing and evaluation in groups. We consider it a relevant question at a theoretical level, to investigate if and how visualization can function as a support for cognitive tasks and for integrating knowledge collaboratively in a group with a common goal. At a practical level, we aim to provide guidelines for choosing or modifying visualizations in order to select the best support for knowledge intensive tasks in group.

To answer this complex and interdisciplinary research question we propose a three step design, which is an integrated combination of different scientific methods [Hollan, 00].

In the *first step* we have started by looking into the literature of diverse related fields (information visualization, diagram studies, knowledge management, management). We have also used qualitative methods to gain insight from the field to integrate the findings from the literature: we have conducted seven semi-structured interviews with practitioners (strategy consultants) and we have observed several meetings in organizations. Through the process explained in [Bresciani, 08] we have proposed a *collaborative dimensions framework*, composed of seven main dimensions mediating the efficacy of visualization in collaborative knowledge work. These dimensions are: visual impact, clarity, perceived finishedness, directed focus, inference support, modifiability and discourse management.

The *second step* consists of matching the most used visualizations in organizations, with typical group activities. We have selected twelve visualizations that are widely and commonly used for facilitating strategic meeting in organizational settings. For each visualization, we have asked survey participants to rate the



usefulness of the visualization (on a 5 point scale) for the following four tasks: idea generation, knowledge sharing, options evaluation and activity planning [Eppler, 05]. At present, we have collected the results of 64 people participating in the survey, all of whom are middle managers, taking part in executives programs in Switzerland. The result of the matching provided us a perception of managers' on visualization methods from the most to the least suitable for each of the four tasks.

The *third step* is the actual experiment. We plan to conduct an experiment using managers (of executive MBA classes) as subjects and asking them to complete two tasks, in groups of five people. Of the previously mentioned typical tasks we choose one divergent and one convergent task, specifically knowledge sharing (divergent) and evaluation (convergent). We create three conditions with different degrees of suitable visualization support. The optimal and suboptimal visualizations are chosen according to the results of the survey conducted in the second step and adapted (to leverage specific dimensions) accordingly to the collaborative dimensions framework, explained in step one. This results in a 3x2 experimental design. To allow for significant results, we will have at least five groups per condition. More details about the design of the experiment are discussed in chapter 3.

At present we have conducted step one and two, generating a framework with seven dimensions [Bresciani, 08] and we have analyzed the results of the matching test. However, we conceive the research design as an iterative process, where new findings in the second and third step, take us back to the beginning and suggest new or different aspects to be considered. We also plan to conduct further matching tests (step two) in the next few months to consolidate the results.

### 3 Experimental Design

In the previous chapter we have briefly explained the third research step, consisting of a 3x2 experimental design, with two tasks: (1) knowledge sharing, (2) evaluation, and three conditions: (I) optimal visualization, (II) suboptimal visualization and (III) no visualization support. The independent variable is the visualization support fit for the task (based on previous findings), and the four dependent variables are: satisfaction (with process and outcome) [Briggs, 06], participation equality [Zmud, 02], productivity [Reinig, 07] and retention (memorability).

#### 3.1 Hypotheses

The main goal of our research is to investigate if the use of an appropriate visualization for a group task improves knowledge work. We decompose this broad goal into measurable and testable hypotheses, based on the aforementioned dependent and independent variables:

H1 Using an appropriate visual support for a task has a positive impact on *satisfaction* compared to using no visual support

H2 Using an appropriate visual support for a task has a positive impact on *participation equality* compared to using no visual support

H3 Using an appropriate visual support for the task has a positive impact on *productivity* compared to using no visual support

H4 Using an appropriate visual support for a task has a positive impact on *retention* compared to using no visual support

With regard to the sub-optimal visualization, we tentatively hypothesize that its effectiveness will be above the un-supported condition.

### 3.2 Task

We conduct the experiment asking groups of five managers firstly to discuss and share their experiences on the problems and pitfalls of *strategy implementation*, and secondly to rank the problems they will have identified in three groups in order of relevance (low relevance, medium relevance and high relevance).

In the first condition, the groups will be provided with one of the best fitting visualizations for the two tasks that have emerged from the matching test: that is the iceberg visual metaphor (Figure 1a) for knowledge sharing, and the matrix for the evaluation task (Figure 1b). In the second condition the groups will have to use a badly fitting visualization support for the task, which is the timeline (Figure 1c) for knowledge sharing and the concept map (Figure 1d) for evaluation. In the third condition, the groups will not be provided with any visualization, but simply with a flipchart.

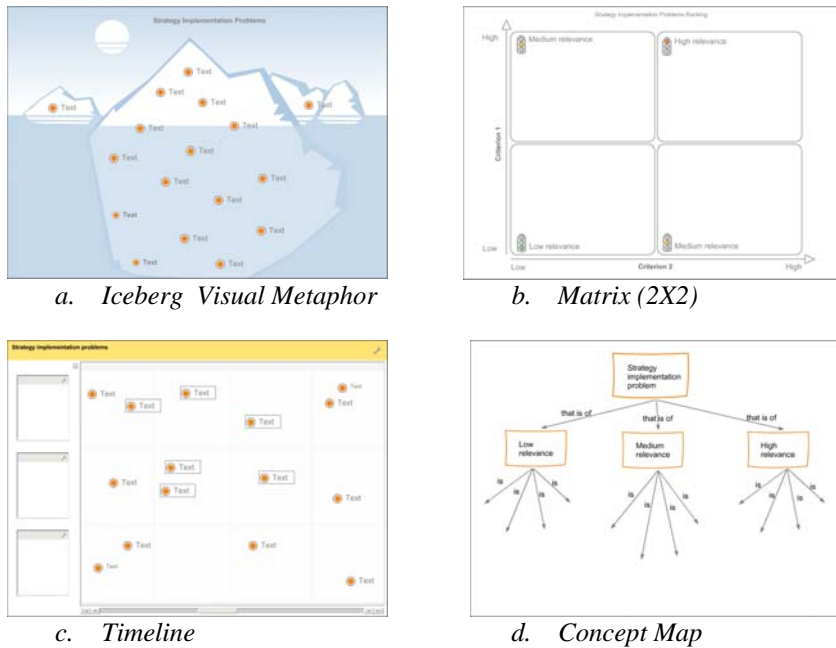

Figure 1: Graphic templates used in the experimental tasks

We will create random groups of five managers from executive MBA classes from Switzerland. The choice of MBA students in this case is particularly suitable because they are managers with at least 5-10 years experience, which is closely the target of typical users we are addressing in our study. They also should have prior

knowledge in strategy and in the process of group decision making. We will have control questions to enquire their experience. The groups will be randomly assigned by the experimenters as suitable in most experimental settings [Campbell, 73][Friedman, 94]. We will have at least five groups for each condition. One member of each group will act as a facilitator who will use the computer and manage the visual facilitation software [Fjermestad, 98] or write on the flipchart.

### 3.3 Measurement

The dependent variables will be measured with both objective and subjective measures. In detail:

1. *Satisfaction*: with process and with outcome. Subjective measures through questionnaire validated scales [Briggs, 06].
2. *Participation equality*: Subjective measures through questionnaire validated scales [Zmud, 02] and objective measures of time talking, derived from the transcripts.
3. *Productivity*: effectiveness: number of admissible non redundant items; number of good ideas [Reinig, 07], (measured comparing literature of strategy implementation problems [Yang, 08]); efficiency: number of deviation from the topic and social talks (focus) derived from the transcripts.
4. *Retention*: quantity of items recalled, completeness and accuracy of ranking, quantity of items mentioned by other people [Brodbeck, 02].

Retention will be measured forty-five minutes after the experiment (after a diversion task of exercises/puzzles), by asking the participants to write down as many strategy implementation problems discussed, as they can remember, and then to rank them as in the group discussion.

We also plan a *debriefing session* after the experiment, where the subjects express their impressions about how they have managed the tasks. In particular they will be asked about the advantages and disadvantages of the support they have used, and relate it with their past experiences. The scope is to collect qualitative data that may shed light on not yet considered topics.

In brief, the experiment will be conducted with the following *procedure*. Before the actual experiment, each person is asked to write *individually* all the strategy implementation problems that they have experienced directly or indirectly. Then the experimenters assign the groups randomly; the participants form the groups and elect a facilitator (the participants are familiar with each other); the selected leaders of the two computer-based conditions are briefly instructed on how to use the software and its main features. They will have ten minutes to familiarize with the software and templates.

All the groups are given the same instructions (one page) to discuss problems of strategy implementation. In the first task they have to share their knowledge and experience and identify strategy pitfalls with the support of the tool provided. Then they are asked to complete the first part of the questionnaire. In the second task they have to rank the identified problems (low, medium, high relevance), with the second visualization provided. Then they fill in the second part of the questionnaires. The groups are randomly assigned to the three conditions. Each group discussion is

recorded with an audio recorder (if the participants permit). The participants are allowed 60 minutes to complete the two tasks and the questionnaires. After the process and a diversion task, the recall exercise is administered. Finally a plenary debriefing session with all the participants is conducted.

The *analysis* of the results will be conducted by two independent coders who will judge the resulting ideas and the transcripts of the recorded dialogues.

As all experiments, the one presented here has *strengths and limitations*: the biggest strength we believe is that the subjects are real managers with several years of experience and they are familiar to each other. The tradeoffs of this choice is that we have constraints in the choice of the procedure because we have to strike a balance between the experimental requirements (such as recording the conversation) and the didactic context of an MBA (such as motivating the participants with educational content, or limiting the questionnaire to a small set of questions). Other *limitations* introduced by the experimental setting include personal differences: different familiarity with strategy implementation and with group support systems may introduce biases in the analysis. For this reason we introduce control questions in the questionnaire measuring familiarity with strategy and with visualization facilitated meetings. Personal preferences for the use of visualization might also have an impact. A further limit is that the subjects of the experiment are managers with very high education level (MBA) and the generalization of the experiment might be limited to experienced managers in Western companies.

### 3.4 Preliminary results

To date, we have conducted a first experiment with 56 managers attending an executive MBA program at the University of Geneva. The data is not yet sufficient to draw statistically significant conclusions and we have plans to replicate the experiment in the near future. However, the data collected thus far is very encouraging: the rough count of the number of strategy implementation problems identified by the groups (part of the effectiveness measure), resulted in an average of 16 items for the computer-supported groups and an average of only 12.5 items for the unsupported groups. We also analyzed the recall tests and we obtained an average of 12.5 items recalled for the visualization supported groups and an average of 8 items for the non supported condition.

We recognize that these are incomplete and inaccurate scientific measures, but we see them as a first confirmation of the feasibility of our experimental design. The preliminary results also show that our effort in measuring the effects of visualization on group meeting support is a promising field of research.

## 4 Conclusions

Our current work focuses on investigating the effect of organizational meetings mediated by computer supported visualization. We have presented the current state of our ongoing research and proposed an experimental design to gain solid insights on the role of visualization for group knowledge sharing and evaluation. We believe that examining this topic is highly relevant, both at a theoretical and a practical level. Our

research hypothesis is that an appropriate visualization support leads to better performance than a non supported or sub-optimal support. We have explained in detail the preceding phases of our research and how we plan to conduct the experiment to test our hypotheses. We have also reported some very preliminary but encouraging results.

This type of research design can easily lead to further investigation of several variants, such as cross-cultural issues [Reinig, 08], comparing mixed groups, comparing different supported visualizations (paper, software, whiteboard), varying group size or task complexity. The experiment has already been planned in a way to allow for cross-cultural comparisons, which we plan to conduct by comparing results of Swiss and Chinese participants. The experiment results could also be integrated with results from the field, such as through context rich field experiments or action research. Alternatively, each of the dimensions of the framework can be investigated in more detail, with a dedicated experiment.

The results of this research are expected to provide solid understanding of the effect of using visualization for knowledge-intensive tasks in organizations. If our hypothesis will be confirmed, the implications will be significant for practitioners in companies, as well as for scholars in several fields, including information visualization, knowledge management and group support systems.

## References

- [Blackwell, 01] A.F. Blackwell, C. Britton, A. Cox, T.R.G. Green, C.A. Gurr, G.F. Kadoda, M. Kutar, M. Loomes, C.L. Nehaniv, M. Petre, C. Roast, C. Roes, and A. Wong, R.M. Young: "Cognitive dimensions of notations: design tools for cognitive technology", in: M. Beynon, C.L. Nehaniv, K. Dautenhahn (Eds.), *Cognitive Technology 2001 (LNAI 2117)*, Springer, Berlin, pp. 325–341, 2001.
- [Bitter-Rijpkema, 02] Bitter-Rijpkema, M., Martens, R., Jochems, W.: Supporting knowledge elicitation for learning in virtual teams, *Educational Technology & Society*, vol. 5, Issue 2, 2002.
- [Bresciani, 07] Bresciani, S., Eppler, M.J.: Usability of Diagrams for Group Knowledge Work: Toward an Analytic Description, Conference proceedings, I-KNOW conference, Graz, Austria, 2007.
- [Bresciani, 08] Bresciani S., Blackwell A.F., Eppler M.J.: A Collaborative Dimensions Framework: Understanding the Mediating Role of Conceptual Visualizations in Collaborative Knowledge Work. Proceedings of the 41<sup>st</sup> Hawaii International Conference on System Sciences, Hawaii (HICSS 08), 2008.
- [Briggs, 97], Briggs, R.O., Reinig, B.A., Shepherd, M.M., Yen J., Nunameker, J.F. Jr., Quality as Function of Quantity in Electronic Brainstorming, Proceedings of the 30th Hawaii International Conference on System Sciences, Hawaii (HICSS 97), 1997.
- [Briggs, 06] Briggs, R.O., Reinig, B.A., de Vreede, G., Meeting Satisfaction for Technology-Supported Groups: an Empirical Validation of a Goal-Attainment Model, *Small Group Research*, Vol. 37, pp. 585-611, 2006.
- [Brodbeck, 02] Brodbeck, F.C., Kerschreiter, R., Mojzisch, A., Frey, D., Schulz-Hardt, S.: The dissemination of critical, unshared information in decision making groups: the effects of pre-discussion dissent, *European Journal of Social Psychology*, Vol. 32, pp. 35-56, 2002.

- [Campbell, 63] Campbell, D.T., Stanley C.J.: Experimental and quasi-experimental design for research, Houghton Mifflin company, USA, 1963.
- [Carey, 97] Carey, J.M., Kacmar, C.J.: The impact of communication mode and task complexity on small group performance and member satisfaction, *Computers in Human Behavior*, Vol. 13, no. 1, pp. 23-49, 1997.
- [Coffey, 04] Coffey W. J., Eskridge, T.C., Sanchez, D. P.: A case study in knowledge elicitation for institutional memory preservation using concept maps, *Proceedings of the First International Conference on Concept Mapping*, Pamplona, Spain 2004.
- [Eppler, 05] Eppler, M., Mengis, J.: Das Management von Wissensdialogen, in: *Zeitschrift für Organisationsentwicklung*, 4/05, pp. 14-23, 2005.
- [Fjermestad, 98] Fjermestad, J., Hiltz, S.R.: An assessment of group support systems experiment research: methodology and results, *Journal of Management Information System*, vol 15, issue 3, pg.7, 143 pgs, 1998.
- [Friedman, 94] Friedman, D. Sunder, S.: *Experimental Methods, A premier for Economists*, Cambridge University Press, Cambridge UK, 1994.
- [Glenn, 04] Glenn W. Harrison, G.W., List, J. A.: Field Experiments, *Journal of Economic Literature*, vol. 42, No. 4, pp. 1009-1055, 2004.
- [Hollan, 00] Hollan, J., Hutchins, E., Kirsh, D., *Distributed Cognition: Toward a New Foundation for Human-Computer Interaction Research*, *ACM Transactions on Computer-Human Interaction*, Vol. 7, No. 2, pp. 174-196, 2000.
- [Lai, 08] Jung-Yu Lai, Chao-Te Wang, Chun-Yi Chou, How knowledge Map and Personalization Affect Effectiveness of KMS in high-Tech firms, *Proceedings of the 41<sup>st</sup> Hawaii International Conference on System Science (HICSS)*, 2008.
- [Mengis, 07] Mengis, J.: *Integrating Knowledge through Communication: An Analysis of Expert Decision Maker Interactions*. PhD Thesis, University of Lugano (USI), Lugano, 2007.
- [Reinig, 07] Reinig, B.A., Briggs, R. O., Nunamaker J.F. Jr., On the measurement of Idea Quality, *Journal of Management Information Systems*, Vol 23, Issue 4, pp. 143-161, 2007.
- [Reinig, 08] Reinig, B.A., Briggs, R.O., de Vreede, G., A cross-cultural investigation of the goal-attainment-likelihood construct and its effect on satisfaction with technology supported collaboration, *Proceedings of the 41<sup>st</sup> Hawaii International Conference on System Sciences, Hawaii (HICSS 08)*, 2008.
- [Shneiderman, 96] Shneiderman, B.: *The Eyes Have It: A Task by Data Type Taxonomy for Information Visualization*, Technical Report 96-66, Institute for Systems Research, University of Maryland, 1996.
- [Yang, 08] Yang, L., Sun, G., Eppler, M.J.: Making Strategy Work: A Literature Review on the Factors influencing Strategy Implementation. in: *ICA Working Paper #2/2008*, University of Lugano (USI), Lugano, Switzerland, 2008 .
- [Zmud, 2002] Zmud, R.W., Mejias, R.J., Reinig, B.A., Martinez-Martinez I.M., Participation equality: Measurement within collaborative electronic environments : a three country study, *Purdue CIBER working papers*, 2002.

## **Handling the Complexity of RDF Data: Combining List and Graph Visualization**

**Philipp Heim and Jürgen Ziegler**  
(University of Duisburg-Essen, Germany  
philipp.heim, juergen.ziegler@uni-due.de)

**Abstract:** An increasing amount of valuable information is stored in RDF. In order to let humans access this information, providing an appropriate visualization of RDF data is an important challenge. In this paper, we present a new approach, combining list and a graph visualization to counterbalance the respective disadvantages of both representation paradigms to better handle the complexity of both the size and the structure of RDF data.

**Key Words:** RDF Visualization, Graph Visualization, Interaction, Data Exploration  
**Category:** H.3.3, H.5.2, M.7

### **1 Introduction**

Web content is typically distributed. With the use of the Resource Description Framework (RDF), the W3C standard to model information for the Semantic Web, web content can be annotated semantically and thus can be exchanged and integrated in an certain and efficient way. This happens by classifying the information contained in web content to certain classes of an ontology and thereby gives the content a well defined meaning.

In order to allow humans to access the meaning that has been given to certain web content and thereby facilitate their understanding of this content, appropriate techniques to visualize RDF data are needed. Since RDF data is organized as a graph, using a graph to present that data to the user seems to be an appropriate approach. The explicit visualization of the RDF graph, the data as it is stored in the computer, guarantees that all the information is displayed, however, it does not guarantee that all the displayed information can be understood by the user.

The problem with directly presenting the RDF graph is that graph visualization does not scale well to large datasets [Frasincar et al 2006]. Their visualization tends to result in a complex graph, which is hardly manageable or understandable by the user [schraefel and Karger 2006]. Additionally, since RDF data is often highly interconnected [Angles and Gutierrez 2005], visualizing all these connections by edges will cause a lot of edge crossings and hence will further hinder the understanding of the information contained in the RDF graph.

List visualizations by contrast are good in dealing with large datasets. Due to their clear and linear way to display data in combination with sophisticated

scrolling and paging techniques as they are implemented in many well known applications, users become empowered to handle large datasets properly. However, lists have very limited abilities in showing multi-dimensional information.

On this account we proclaim a combined approach using both, a list to display large datasets in a clear way and a graph to show multi-dimensional information in its structural complexity. The use of both representation paradigms counterbalances their respective disadvantages and thereby facilitates an enhanced understanding of the information contained in RDF data.

## 2 Related Work

Making semantic information represented in RDF accessible for users has been addressed by several projects.

Graph-based tools such as RDF Gravity [Goyal and Westenthaler 2004], IsaViz [IsaViz 2006], Welkin [Welkin 2005] and the Paged Graph Visualization [Deligiannidis et al. 2007], display RDF data as node-link diagrams, explicitly showing its internal representation structure.

Other tools like Longwell [Longwell 2005], Haystack [Quan et al. 2003], m-Space [schraefel et al. 2005] and Tabulator [Berners-Lee et al. 2006] use lists in combination with the faceted browsing paradigm [Yee et al 2003] to visualize and browse arbitrarily complex RDF datasets, allowing the end users to alter their search criteria at each step of the exploration.

A mixed approach, however, allowing the user to switch from one visualization to the other in a smooth transition, has to our best knowledge not been addressed so far. So with the RDF-ListGraph we present a first attempt in combining a list with a graph to improve the accessibility of RDF data.

## 3 RDF-ListGraph

The RDF-ListGraph is a tool to visualize RDF data as both a list and a graph. The user can switch between list and graph visualization in order to look at the same data in differing ways. The change from one visualization to the other happens in a smooth transition to not confuse the user and thereby rather hinder an understanding of the RDF data than to support it. To provide a smooth transition we use Adobe Flex, an open source framework for building rich Internet applications, using Flash's animation power. The RDF data to be viewed in the RDF-ListGraph is requested by the use of SPARQL, a protocol and RDF query language, allowing to access RDF data from every location with Internet access. The accessed data can then be visualized in any browser with Flash plug-in.

The RDF-ListGraph is developed within the context of the research project Softwiki [Softwiki 2008] that aims to support the collaborative requirement engineering process of large and spatially distributed groups of stakeholders. The



stakeholders are enabled to semantically enrich requirements and integrate them in an ontology where central classes like requirement, description and keyword are defined. Classified that way, the requirements are stored in RDF, leading to large RDF datasets. These datasets can be visualized by the RDF-ListGraph to analyze the complexity of the semantically enriched requirements and thus discover interesting relationships between them.

The analysis process with the RDF-ListGraph starts with the definition of the class of instances the user is interested in, for example the class of all requirements. Thereafter, all the existing requirements get visualized as a list, which can be controlled by filters. Having found a set of interesting instances, the user has the opportunity to change the representation paradigm and switch smoothly animated to a graph-based visualization. Since the structural complexity of RDF data can often not be understood in the direct visualization of the RDF graph, a specific graph transformation is applied to enhance users' understanding of this complexity. So the RDF-ListGraph in comparison to existing RDF visualization tools provides the three following key advantages:

1. The combination of list and graph visualization to handle the complexity of RDF data in both size and structure.
2. A smoothly animated transition between both representation paradigms to make the change clear and traceable.
3. A specific graph transformation to directly show similarities between certain instances.

#### 4 Using a List to Handle Large Datasets

Since RDF data is often large in size, the RDF-ListGraph has to be capable in dealing with large datasets. Therefore the RDF-ListGraph provides a list visualization together with different kinds of filters to iteratively narrow down a possibly large set of RDF data in order to end up with a small set of instances, which is of special interest to the user.

In order to control what information to display, the user can apply the following three different filters: The *class filter*, the *property filter* and the *display filter*. With the *class filter* the user can narrow down the search space to instances of a certain class, for example requirements (see figure 1, A). The number of instances can then be reduced by the *property filter* to only instances with specific properties, for example to requirements with keywords "spam" or "junk" (see figure 1, B). Additionally, the *display filter* can be used to show or hide certain properties of the found instances and to highlight properties of special interest by different colors, for example the properties "Keyword spam" and "Keyword junk" (see figure 1, C).

The screenshot displays a search interface on the left and a list of results on the right. The search section includes a dropdown menu (A) set to 'Requirement', radio buttons for 'with all of the following properties' and 'with at least one of the following properties', a 'Keyword' input field (B) with a dropdown, and a 'Show results as:' dropdown (C) set to 'List'. Below this is a 'highlight' button and another 'Keyword' input field. The results list (D) is a table with columns 'Title' and 'Keywords'. The items are: 'add button to hide spam' (spam, button), 'virus detection' (spam, detect, security), 'check sender address' (junk), 'block scripts' (spam, security), 'spam assassin' (junk, spam), 'junk filter' (junk, detect, delete), and 'spam detection' (spam, delete). The 'spam assassin' item is expanded to show a description: 'Several method to detect and delete spam are needed. The method should be able to get trained and quality evolutionary.'

**Figure 1:** The list visualization shows information in a clear and linear way.

Each modification of the filters leads to an update of the list, allowing the user to instantly notice the effects caused by the modification. Because a list is a well known representation paradigm and frequent changes of the displayed information do not result in new layouts, but stay in the same linear structure, the user do not get lost while narrow down the list by filters. The possibility to order the list by certain properties can additionally help to force the list in a clear structure to better keep track of changes and updates. To see the instances in more detail, for example to see the description of a requirement (see figure 1, D), the user can open and close them via a dropdown method. It is possible to open several instances simultaneously and hence become able to better compare them in detail. So the list acts as a multi-accordion where instances can be opened and closed user-defined and independently.

Until this point the list is suitable, but lacks capability to present a small set of instances in all its structural complexity. This is mainly the case, because the ability of lists to linearly arrange information has the serious disadvantage that it is not suitable to show non-linear information in all its multiplicity. Only one dimension can be represented properly by a list at one time. So in which way the instances in the set interrelate according to their properties cannot be properly shown by list visualization. In this specific situation, graph visualization seems to be the better visualization paradigm.

## 5 Using a Graph to Handle Structural Complexity

In order to understand the information contained in RDF data, it is important to understand how it is structured. A closer inspection of the data structure can unveil patterns such as dependencies between certain properties. The knowledge of possible dependencies can help to better interpret and understand certain aspects of the information. Since RDF data commonly consists of instances that share multiple properties, their possible dependencies are multi-dimensional. In order to allow the user to discover multi-dimensional dependencies in RDF data, we use a graph visualization to present multi-dimensional data in an appropriate way. The standard RDF graph, however, does not suit the task of discovering dependencies, because equal properties are not directly visualized. To make it easy for the user to spot equal properties and hence facilitate the discovery of dependencies, we transform the standard RDF graph into a graph where shared properties are directly visible.

### 5.1 Graph Transformation

In the transformed graph, only properties shared by at least two instances are visualized. The advantage of this approach is to help users to focus on those properties shared by several instances.

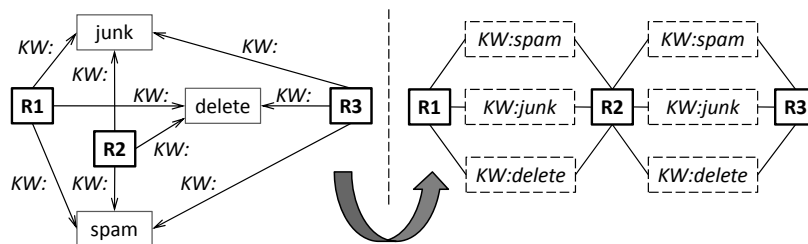

**Figure 2:** The RDF graph is transformed to better discover similarities

A second advantage is that equal properties are directly represented by labeled edges what makes similarities directly visible for the user. In the visualization of the standard RDF graph by contrast, equal properties are not directly visible and hence are hard to spot for the user. As can be seen in figure 2, the requirements R1, R2 and R3 in the transformed graph are connected by labeled edges according to their three equal properties *KW:spam*, *KW:junk* and *KW:delete*, making it easy to recognize similarities between requirements.

A third advantage of the transformed graph is a fewer number of crossing edges. Where in the RDF graph instances with the same property are connected to one and the same node (see figure 2, left), in the transformed graph they are arranged in a row (see figure 2, right). Having several instances connected to one and the same node brings up the question of shortage of space around this node. Since the space around a node is limited, the more instances are connected to the same node, the more they get clustered. With several instances sharing several properties, their clustering results in crossing edges, as it is the case in figure 2, on the left side. The transformed graph reduces the clustering by using a row to arrange instances with the same property instead of using a circle as it is in the RDF graph and thus avoid edge crossings (see figure 2, right).

### 5.2 Graph Visualization

In the graph visualization of the RDF-ListGraph, instances are represented by nodes and connected by labeled edges. To layout the graph in an aesthetically pleasing way, we use a force directed algorithm [Fruchterman and Reingold 1991] to position the nodes of the graph so that all the edges are of more or less equal length and there are as few crossing edges as possible (figure 3).

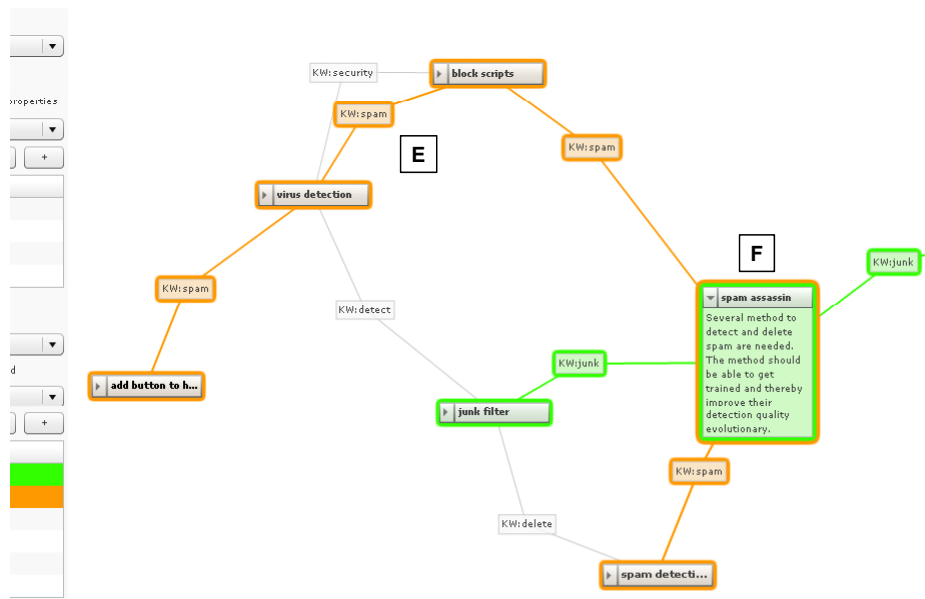

Figure 3: The graph visualization shows interrelations directly.

Since even in simple settings the problem of automatic label placement turns out to be NP-hard [Christensen et al 1995], we treat the labels as additional nodes to get the placement solved along with the computation of the force directed layout. Treating a label as a node divides the connections between two instances into two edges with the label as articulated joint in between (see figure 3, E). With a connection consisting of two edges and an articulated joint in between, the shape of an edge gets more flexible and hence avoids overlapping when two instances are connected by more than one edge.

If two instances share a property, they get connected by an edge, which is labeled by that property. If two instances share several properties, they get connected by several edges and therefore get positioned close to each other in the force directed layout of the graph (see figure 3, E). Every property can be highlighted by a specific color, making it easy for the user to see how instances interrelate by certain properties. If an instance interrelates with other instances by more than one property that is highlighted by the user, it gets surrounded by as many colored rings as there are similarities with this instance (see figure 3, F). That way, instances with certain properties are marked by certain colors and thus are easy to find in the graph.

## 6 Conclusions and Future Work

In this paper we introduced the RDF-ListGraph, a tool that offers the user both, a list to handle large datasets and a graph to show the structure of a selected set of instances in all its complexity. To not confuse the user when switching the representation paradigm, the change from a list to a graph and vice versa is smoothly animated in Flash. That way the RDF-ListGraph counterbalances the respective disadvantages of both representation paradigms and let the user handle the complexity of RDF data in both, size and structure.

We also introduced a specific graph transformation that makes similarities directly visible and thereby further facilitate the understanding of the interrelations within the set of instances. Finally, the *class*, the *property* and the *display filter*, allow the user to narrow down large datasets in order to focus on information of special interest.

In our future work we will evaluate our approach by user studies and work on a further integration of the two paradigms to reduce the cost of changing between list and graph visualization. Soften the strict separation between both visualization states seems therefore to be a promising approach. So, offering several stable states in-between list and graph visualization could improve the combination of both representation paradigms and hence further facilitate the understanding of the information contained in RDF data.

## References

- [Angles and Gutierrez 2005] Angles, R., Gutierrez, C.: “Querying RDF data from a graph database perspective”; Proceedings of the 2nd European Semantic Web Conference (ESWC), Greece (2005), 346-360.
- [Berners-Lee et al. 2006] Berners-Lee, T., Chen, Y., Chilton, L., Connolly, D., Dhanaraj, R., Hollenbach, J., Lerer, A., Sheets, D.: “Tabulator: Exploring and Analyzing linked data on the Semantic Web”; Proceedings of the 3rd International Semantic Web User Interaction Workshop (2006).
- [Bizer et al. 2006] Bizer, C., Pietriga, E., Karger, D., Lee, R.: “Fresnel: A Browser-Independent Presentation Vocabulary for RDF”; Proceedings of the 5th International Semantic Web Conference, LNCS 4273, Springer, Berlin.
- [Christensen et al 1995] Christensen, J., Marks, J., Shieber, S.: “An empirical study of algorithms for point-feature label placement”; ACM Transactions on Graphics (1995), 203-232.
- [Deligiannidis et al. 2007] Deligiannidis, L., Kochut, K., Sheth, A.: “RDF data exploration and visualization”; Proceedings of the ACM first workshop on CyberInfrastructure, New York (2007), 39-46.
- [Frasincar et al 2006] Frasincar, F., Telea, A., Houben, G.-J.: “Adapting graph visualization techniques for the visualization of RDF data”; Visualizing the Semantic Web (2006), 154-171.
- [Fruchterman and Reingold 1991] Fruchterman, T., Reingold, E.: “Graph drawing by force-directed placement”; *Softw. Pract. Exper.*, John Wiley & Sons, New York, 1129-1164.
- [Goyal and Westenthaler 2004] Goyal, S. and Westenthaler, R.: RDF Gravity; Salzburg Research (2004). <http://semweb.salzburgresearch.at/apps/rdf-gravity/>.
- [IsaViz 2006] IsaViz: A Visual Authoring Tool for RDF (2001-2006). <http://www.w3.org/2001/11/IsaViz/>.
- [Longwell 2005] SIMILE: Longwell RDF Browser (2003-2005). <http://simile.mit.edu/longwell/>.
- [Quan et al. 2003] Quan, D., Huynh, D., Karger, D.: “Haystack: A Platform for Authoring End User Semantic Web Applications”; Proceedings of the 2nd International Semantic Web Conference (2003), 738-753.
- [schraefel and Karger 2006] schraefel, m. c. and Karger, D.: “The Pathetic Fallacy of RDF”; International Workshop on the Semantic Web and User Interaction (2006).
- [schraefel et al. 2005] schraefel, m.c., Smith, D., Owens, A., Russell, A., Harris, C., Wilson, M.: “The evolving mspace platform: leveraging the semantic web on the trail of the memex”; Proceedings of the sixteenth ACM conference on Hypertext and hypermedia, New York (2005), 174-183.
- [Softwiki 2008] Softwiki (2006-2009). <http://www.softwiki.de>.
- [Welkin 2005] SIMILE: Welkin (2004-2005). <http://simile.mit.edu/welkin/>.
- [Yee et al 2003] Yee, K.-P., Swearingen, K., Li, K., Hearst, M.: “Faceted metadata for image search and browsing”; Proceedings of the ACM Conference on Computer-Human Interaction (2003).

## **Semantic Search and Visualization of Time-Series Data**

**Tatiana Tekušová**

(Fraunhofer IGD, Darmstadt, Germany  
tatiana.tekusova@igd.fraunhofer.de)

**Viktor Voss**

(Technische Universität Darmstadt, Darmstadt, Germany  
viktor.voss@gris.informatik.tu-darmstadt.de)

**Jörn Kohlhammer**

(Fraunhofer IGD, Darmstadt, Germany  
joern.kohlhammer@igd.fraunhofer.de)

**Abstract:** In the economic and financial analysis domain a quick access to the right information plays a major role. Using current systems, the search for and presentation of data is very cumbersome. The data, mostly in form of time-series, is stored in various databases. In order to retrieve the searched data, the analysts need to know where to search and sometimes even the structure of the database and its coding. Then it is required to export the data, process the data and create a chart to view the data. This might take time from tens of minutes to hours. In our work we present a first prototype of an integrated search engine that takes as input a natural language query and offers graphic and text output depending on the user task. The system automatically identifies the time-series answers, types of graphical data presentation and shows the results in a web browser and in Excel. The knowledge-based expert system uses domain ontologies for extraction of economic terms in the search queries and specially built data type taxonomy with user task and chart type ontologies for identification of graphic output.

**Keywords:** Semantic Data Retrieval, Search Result Visualization, Information Visualization, Expert Systems, Economic and Financial Data, Time Series Visualization

**Categories:** H.3.1, H.5.2, H.5.m, J.4, M.6

### **1 Introduction**

In the economic and financial analysis a quick access to the right information plays a major role. Often large amounts of data have to be evaluated in short time. The data are usually stored in heterogeneous systems and in various databases. In their work, analysts combine numerical data from various sources with text (such as news, reports, etc.), and expertise that exists in the company.

In order to collect all the needed information, analysts spend a lot of time every day with information search. Analysts usually simply browse the data sources, or use data search options available by the data provides. These conventional systems for searching for financial and economic information, however, do not offer naturally formulated search queries such as “GDP composition in Germany” with direct graphical output.

The finding of relevant data does not finish the analysis task. In the analysis process, after the data is sought, the data is copied by hand into another system for further processing (e.g. into Excel). Finally, appropriate graphics for data presentation are created. The graphic construction requires from the analyst, in addition to the domain expertise, also skills in information visualization and graphic design.

In this paper, we introduce a first prototype of a semantic-based search engine which takes as input a natural language query, searches over financial information in across multiple financial data services and displays the results in a way that suits best the user tasks (e.g. as table, text or graph). A preliminary user study to examine the common analytic tasks with matching answers was conducted. In later stage, selected end-users were asked for feedback. Results of both studies are presented.

The paper is structured as follows: Section 2 discusses relevant work about automatic graphic data presentation. The third section describes current user search tasks and used systems for data search. In the following section, our framework is presented. Section 5 provides examples of search output visualization. Finally we conclude and discuss further work.

## 2 Related Work

Automatic generation of graphical data representation goes back to the work of MacKinlay [Mackinlay, 86]. The Automatic Presentation Tool (APT) defines graphic representation based on description of visual attributes. According to visualization design methodology, we can divide current systems into two categories - constructive bottom-up and template-based top-down method [Kamps, 99]. The comparison of the two techniques can be found in [Lang, 06].

The development of data type and visualization taxonomy, was based on work of Shneiderman [Shneiderman, 96] and by Tory et al. [Tory, 04] which match different data types with visualization driven by user tasks. A general overview of analytic tasks in visualization is provided by Amar et al. [Amar, 06]. Amar et al. [Amar, 04] also describe a knowledge task-based framework for design and evaluation of information visualizations. Fujishiro et Al. [Fujishiro, 00] describe a taxonomic approach to semi-automatic design of information visualization applications using modular visualization environment. An overview of visualization techniques specialized for time-series can be found in [Aigner, 07], taxonomy for temporal data visualizations can be found in [Daassi, 06]. Kohlhammer [Kohlhammer, 05] describes the use of domain ontologies for effective visualization.

## 3 User Tasks and Current State of Data Search

### 3.1 Search Tasks

In order to best meet the analytic requirements, we have asked ten financial and economic analysts, from various work domains, which search engines they use to find the data and what systems they use for data presentation. They were asked to provide as many data queries with their desired outcomes and estimation of the time needed to accomplish the analytic task as possible (see Table 1).



More than two thirds of the searches are aimed at getting data in tables, single data observations or data charts (see Figure 1, left). Chart responses included line, column, stacked column and scatterplot charts. The respondents use financial and internal databases. They wish to copy the data to create a chart in Excel.

The time needed to accomplish the task (from data search to production of the relevant data presentation) varies strongly according to the desired output and the expertise in the searched data sources. Searching for novel information, not used by the user on a regular basis, is much more time demanding than a search for data where the data source is already known. On average, users spend 18 minutes when creating tables and only 3 minutes when looking for a single value. However, the span between minimum and maximum time is very high (see Figure 1, right) reaching a maximum time spent for one task of 4 hours.

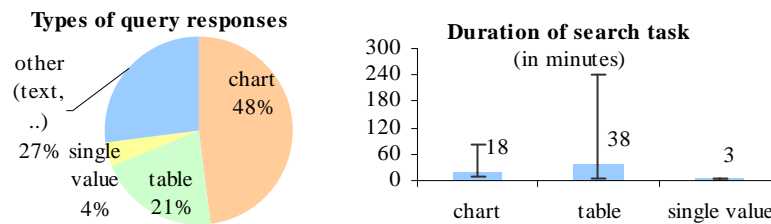

Figure 1: Required search query responses. Left: Types of search responses, Right: Time needed for response by type (average, minimum and maximum)

Question	Expected Output	Expected Duration
Show me EUR/SKK development in the last week	Intra-day line chart.	5mins
DJI index in the past year	Tick data, line chart	5mins
Show me GDP composition in Germany and France?	2 pie charts showing GDP components	30 mins

Table 1: Example Questionnaire answers

### 3.2 Data Sources and Currently Used Search Engines

The sources of information needed are spread across multiple data bases from various data providers (e.g. Bloomberg, Reuters, DataStream, Eurostat, ECB or internal sources). Each data provider uses own data classification system and data description system making the search for data across databases very complicated. Search in such databases is usually constrained to explorative overview of database entries by category. Some providers offer search engines which should facilitate the search for data. These search functions, in general, offer as outcome long lexicographic ranking (lists) of the names of the available time series (see Figure 2).

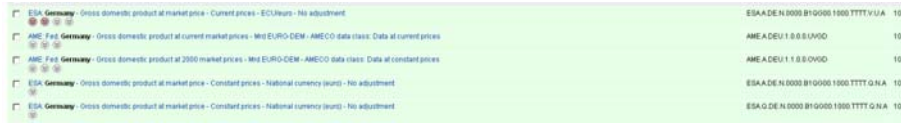

Figure 2: Example of search results using ECB search engine (<http://sdw.ecb.int>).

## 4 Semantic based Time-Series Search and Visualization

### 4.1 Search and Visualization Framework

Our knowledge-based system for integrated data search and visualization consists of three major parts (see Figure 3): in the first stage the input query is processed in order to extract relevant search criteria, then a suitable set of responses is compiled, extracted from the database and finally the responses are shown in a web browser. Our system is based on Conweaver framework [Conweaver]. ConWeaver provides automated knowledge network construction, semantic integration and intelligent search in portals and intranets.

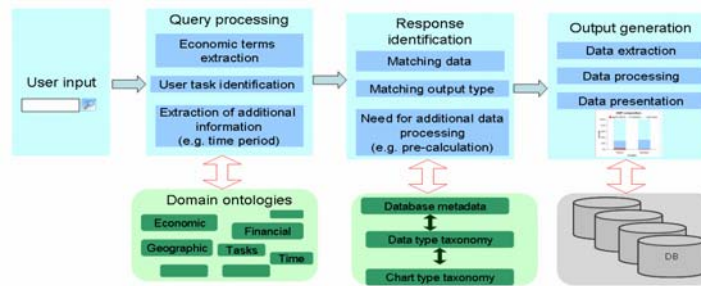

Figure 3: System framework

### 4.2 Query processing and Response Identification

In the first stage, the input query is processed in order to extract economic and financial terms in the query. In our work, we have created modules that identify economic and financial terms in the data descriptions, by looking for longest terms first. For example “GDP per capita” is a different term than “GDP”. Furthermore synonyms (consumer prices and inflation) and abbreviations (e.g. GDP = gross domestic product) can be extracted.

For defining the suitable data presentation type, we have analyzed visualization types used in the financial and economic domain and user study. A template based system for graph generation, which can be adjusted by the users, is applied. In the system, each chart type is described by type of data input, visualization parameters and analytic purpose (keywords).

For each chart type identified in the user questionnaire (line, column, pie, scatter plot, etc.), a description was created and saved in the chart type ontology. It describes types of data that the specific chart can use as input and the user tasks for each chart

type. Each chart parameter (each chart axis) is described via the type of data that it takes as input (quantitative, nominal, ordinal, etc.) and its cardinality. For example a line chart has 3 “axis”: X axis that usually takes quantitative data of cardinality  $>5$ , Y Axis takes quantitative data of cardinality  $\geq 1$ , and Legend takes nominal data of cardinality 1-10 (more than 10 series usually make the graph overcrowded). Chart is also characterized by “keywords” indicating user task connected to the specific chart type. The keywords were identified via matching search queries with expected responses (see in Table 1). For example, “composition” indicates pie chart, “development” indicates line chart.

### 4.3 Output generation

In the output generation stage, the identified suitable response data are collected from the database. The output type is influenced by the rank of matching data, the goodness of fit of the data to specific chart types and user task match with the chart keywords... The output data type and the identified user task are matched with the best possible visualization type. The chart type match (see Figure 4) uses weighted data type hierarchy for defining the best possible output type for a given data set to be shown. The output match is quantitatively expressed by the product of the data type hierarchy step weights. The weights are pre-set parameters, which can be adjusted. Additionally the user tasks influence the output type. Additionally, the the weight of each chart type is influenced by match of chart keywords with the search query. A ranking list of output types is thereby created. The top ones are used in the output visualization.

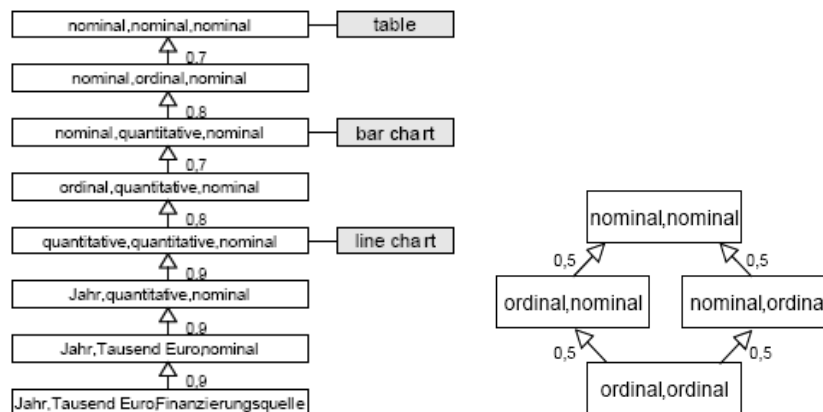

Figure 4: Semantic search for visualization type. Data set type hierarchy.

## 5 Search System Output and Evaluation

For testing the search and visualization framework, real world data set from the Federal Reserve Bank of St. Louis (<http://research.stlouisfed.org/fred2/>) were used. The FRED® database contains about 14000 economic and financial time series in flat text files. It provides raw data and time series descriptions.

The engine displays the search results on a Web frontend in the form of dynamically generated HTML pages based on search results. The data that match best the user query are displayed in a graphical form determined in the response identification phase (see Figure 5). In our prototypic application, the user may click on each chart to see the underlying data table in Excel (see Figure 6). The users can then further process the data results or design further charts in this application. On demand other export formats can be employed. In addition to numeric data, the search engine offers a list of documents searched on the internet using common text search engines (e.g. Google). Using the ConWeaver system [Conweaver] we could have easily included also search in internal documents, however we did not have any such data at disposal. This provides a composite of relevant information in one window.

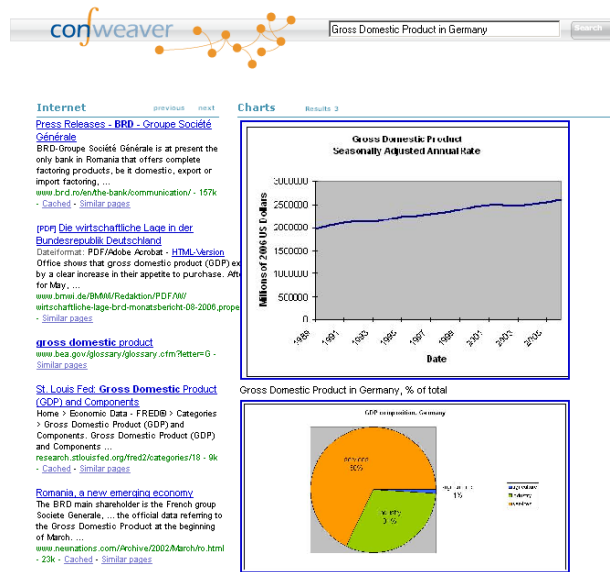

Figure 5: Example search result using our prototype tool

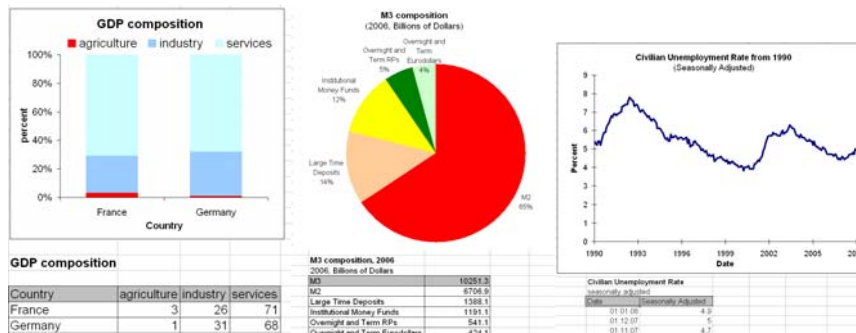

Figure 6: Selected user responses exported into Excel

The prototype user queries were used to test the results of our search engine. The users liked very much the possibility to see an overview of the search responses in graphic/table format. It enables them to quickly identify major data developments without cumbersome data export and graph creation for each single data series. This quick and easy way of preliminary data analysis saves the analysts' time which they can use for more in depth data analysis using e.g. data mining methods.

## **6 Conclusions**

A prototype system for search in economic time-series databases which takes as input a natural language query, and graphically visualizes the search results has been developed. The choice of the proper visualization type is task-dependent using data taxonomy and visualization type ontology. Domain ontology for economic data is used for finding suitable search response. The system offers time saving to the potential users when looking for and presenting economic and financial data allowing them to concentrate on the data analysis part of the analytic process.

## **7 Future Work**

In near future we would like to explore the effect of different parameter set-up for hierarchy type match. It would be also needed to expand the used financial and economic ontologies using new data sources (e.g. further classifications) and newly developed publicly available ontologies. This would allow for more accurate search responses. We would like to include automatic data processing using financial functions (e. g. calculation of indices) and widen the spectrum of used visualization techniques. It would be interesting to combine search for numeric data with search in news feeds. For example, particular patterns (peaks, strong decreases) could be matched with the relevant stock market interpretation.

## **Acknowledgements**

The authors thank the ConWeaver Company, especially Richard Stenzel and Thomas Kamps for their support and the possibility to use their engine for semantic search. We are thankful to the user study participants for their activity and helpful input. We would like to thank Tobias Schreck for helpful comments. This research was partly funded by the German Federal Ministry of Economics and Technology within the THESEUS project (<http://theseus-programm.de>).

## References

- [Aigner, 07] Aigner W., Miksch S., Muller W., Schumann H., Tominski Ch.: Visualizing time-oriented data--A systematic view, *Computers & Graphics*, Vol. 31, No. 3. (June 2007), pp. 401-409, 2007.
- [Amar, 04] Amar, R.; Stasko, J.: A Knowledge Task-Based Framework for Design and Evaluation of Information Visualizations, In Proc. IEEE Symposium on Information Visualization, 10-12 Oct 2004, pp. 143-150, 2004
- [Amar, 06] Amar, R., Eagan, J., Stasko, J.: Low-Level Components of Analytic Activity in Information Visualization. Georgia Institute of Technology, 2006
- [Audersch, 05] Audersch, S., Flach, G.: Semantic Web Technologien für die visuelle Exploration und Fusion multivariater Datenbeständen. In Proceedings of Berliner XMLTage, 2005
- [Berners-Lee, 01] Berners-Lee T., Hendler, J. und Lassila, O.: The Semantic Web – A new form of Web content that is meaningful to computers will unleash a revolution of new possibilities. *Scientific American*, 2001
- [Card, 99] Card, S.K., Mackinlay, J.D., Shneiderman, B.: Readings in Information Visualization. Using Vision to Think. Morgan Kaufmann, 1999
- [Codd, 70] Codd E. F.: A Relational Model of Data for Large Shared Data Banks, *Communications of the ACM*, Volume 13, Number 6, pp. 377-387, 1970
- [Conweaver] [www.conweaver.de](http://www.conweaver.de), accessed 7<sup>th</sup> April 2008
- [Cox, 01] Cox, K., Grinter, R.E., Hibino, S.L., Jategaonkar Jagadeesan, J., Mantilla, D.: A Multi-Modal Natural Language Interface to an Information Visualization Environment. *International Journal of Speech Technology*, 2001
- [Daassi, 06] Daassi C., Nigay L., Fauvet M.-C. : A taxonomy of temporal data visualization techniques, *Revue en Sciences du traitement de l'Information*. Cépaduès Editions., vol5, no2, pp. 41-63, 2005.
- [Date, 00] Date, C.J: An Introduction to Database Systems, 7th Edition. Addison- Wesley, Reading, MA, USA, 2000
- [Fujishiro, 00] Fujishiro, I.; Ichikawa, Y.; Furuhashi, R.; Takeshima, Y.: GADGET/IV: a taxonomic approach to semi-automatic design of information visualization applications using modular visualization environment, In Proc. IEEE Symposium on Information Visualization, 2000. InfoVis 2000. 9-10 Oct. 2000 Page(s):77 – 83, 2000
- [Kamps, 99] Kamps, T. M.: A Constructive Theory for Diagram Design and its Algorithmic Implementation, PhD Thesis, Technische Universität Darmstadt, 1999
- [Kohlhammer, 05] Kohlhammer, J., Encarnaçao, José L. (Referent), Knowledge Representation for Decision-Centered Visualization, (Dissertation, Technical University of Darmstadt), GCA-Verlag, Reihe: Forschung und Wissen - Informatik, Herdecke, 2005
- [Lange, 06] Lange, S., Nocke, T., Schumann, H.: Visualisierungsdesign – ein systematischer Überblick, German, „Visualization design – a systematic overview“, Universität Rostok, 2006
- [Mackinlay, 86] Mackinlay, J.: Automating the Design of Graphical Presentations of Relational Information. *Transactions on Graphics*, Vol. 5, Nr. 2 , April VI 1986

[Shneiderman, 96] Shneiderman, B.: The Eyes Have It: A Task by Data Type Taxonomy for Information Visualization. Proc. 1996 IEEE Conference on Visual Languages, 1996

[Sowa, 91] Sowa, J. F.: Principles of semantic networks. Explorations in the representation of knowledge. Morgan Kaufmann, 1991

[Tory, 04] Tory, M.; Moller, T.: Rethinking Visualization: A High-Level Taxonomy, In Proc. IEEE Symposium on Information Visualization, 10-12 Oct. 2004 Page(s):151 – 158, 2004

[Ware, 99] Ware, C.: Information Visualization: Perception for Design, Morgan Kaufmann, 1999

## Understanding Interlinked Data

– Visualising, Exploring, and Analysing Ontologies –

**Olaf Noppens and Thorsten Liebig**

(Ulm University, Germany)

olaf.noppens@uni-ulm.de, thorsten.liebig@uni-ulm.de)

**Abstract** Companies are faced with managing as well as integrating large collections of distributed data today. Here, the challenging task is not to store these volumes of structured and interlinked data but to understand and analyze its explicit or implicit relationships. However, up to date there is virtually no support in navigating, visualizing or even analyzing structured data sets of this size appropriately. This paper describes novel rendering techniques enabling a new level of visual analytics combined with interactive exploration principles. The underlying visualization rationale is driven by the principle of providing detail information with respect to qualitative as well as quantitative aspects on user demand while offering an overview at any time. By means of our prototypical implementation and a real-world data set we show how to answer several data specific tasks by interactive visual exploration.

**Key Words:** metadata, visual analytics, interactive exploration

**Category:** I.2.4, H.3.3, H.5.2

### 1 Motivation

Making value from collecting and integrating distributed and heterogeneous data is a critical factor of business success. In fact, the underlying problem is a very general kind of challenge of our information society and closely related to community efforts such as DBpedia [Auer et al., 2007] or YAGO [Suchanek et al., 2007] which have recently extracted large volumes of structured data from the Web (Wikipedia, US Census Data, WordNet, etc.). Those repositories are extreme in the sense that they are extraordinary in size and dominated by interlinked data incorporating only a small and typically lightweight schema. However, there is currently only little or no adequate support in navigating, visualizing or even analyzing large volumes of interlinked data in an reasonable way.

In this paper we present our approach which combines techniques from visual analytics and interactive exploration suitable even to grasp large volumes of heavily interrelated data sets. The approach has been implemented and integrated into our ontology authoring framework ONTOTRACK [Liebig and Noppens, 2005]. The following describes the various selection, exploration and analysis techniques with help of an example data set introduced in the next section.



## 2 The MONDIAL Database

For illustrating purposes we have chosen a simple but real-world data set, namely the Mondial Database<sup>1</sup> (MONDIAL). It consists of a collection of geographic information compiled from different Web data sources such as the CIA World Factbook, Global Statistics and the Terra database [May, 1999]. The core of a MONDIAL record consists of data about countries, cities as well as deserts, rivers, or ethnic groups mainly collected from the World Factbook. In addition the collection includes statistical data about populations, area, or length. Entities are typed in a lightweight manner with respect to common geographical concepts such as countries, rivers etc. The most substantial information, however, is expressed by the various relationships which relate entities among each other. For instance, the relationship **has-City** relates countries to cities, **flows-through-country** tells us through which countries a river flows to, etc.

## 3 Related Work

Understanding knowledge from a visual perspective is a challenge when it comes to large amounts of entities as well as interconnections. Whereas charts help to gain insights to numerical data sets they are not appropriate to depict qualitative relationships.

Current tools for the latter task typically try to combine visualization with interaction in a sense that users can chose between sets of entities they want to inspect or types of relationships they wants to investigate.

A representative of the former is the MatrixBrowser tool [Ziegler et al., 2002]. It allows to select two sets of entities in order to visualize the existing relationships between the set members with help of a 2D matrix as shown in Fig. 1. Here, the x-axis lists all countries and the y-axis all rivers of the MONDIAL data set. A relationship between a specific river and various countries is depicted by a mark in the corresponding intersecting field and connecting horizontal and vertical lines. For instance, Fig. 1 shows the relation **flows-through-country** between the river Argun and Russia. However, in case of only sparsely related individuals a lot of space is left unused. In addition, large data sets can not be displayed on one screen and hamper to grasp the 'big picture'. Furthermore, due to the nature of a two-dimensional matrix, only the relationships between two kinds of characteristics can be visualized and analyzed at once.

A different paradigm, namely a network centered approach is implemented within Welkin [Mazzocchi and Ciccicarese, 2007]. Welkin as well as other RDF visualizing tools such as RDF-Gravity and ISAViz utilize either spring, circle, or tree layout techniques for rendering graphs. Typically the user selects a type

<sup>1</sup> <http://www.dbis.informatik.uni-goettingen.de/Mondial/>

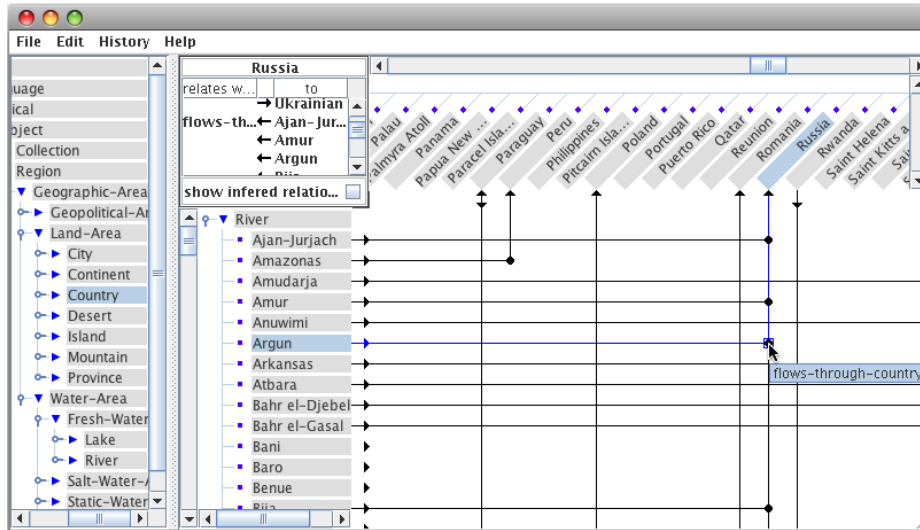

Figure 1: MatrixBrowser visualization of rivers flowing through countries.

of relationship and the corresponding network renders all existing connections of this type. For instance, Fig. 2 shows the same correlation of rivers to countries with respect to the `flows-through-country` relationship as in Fig. 1. This approach obviously is able to show the connectivity within larger data sets. However, it lacks of quantitative information, may distract in case of many interconnections, and provides no clear distinction between different types of entities.

For the purpose of comparison see the left hand side of Fig. 6 in order to get an idea how the aforementioned coherences are displayed within our approach.

#### 4 Visual Analysis through Interactive Exploration

When visualizing ontologies one needs to take their inherent characteristics into account. Therefore our novel visualization paradigm tries to consider *qualitative* aspects such as clustering of individuals with respect to explicit/implicit concept and relationship assertions as well as *quantitative* aspects as shown in the following.

##### 4.1 Visualizing Qualities

Several studies have shown that it is not advisable to arbitrarily visualize both all dependencies and all particulars at any time [Keim, 2001]. Therefore, in order to

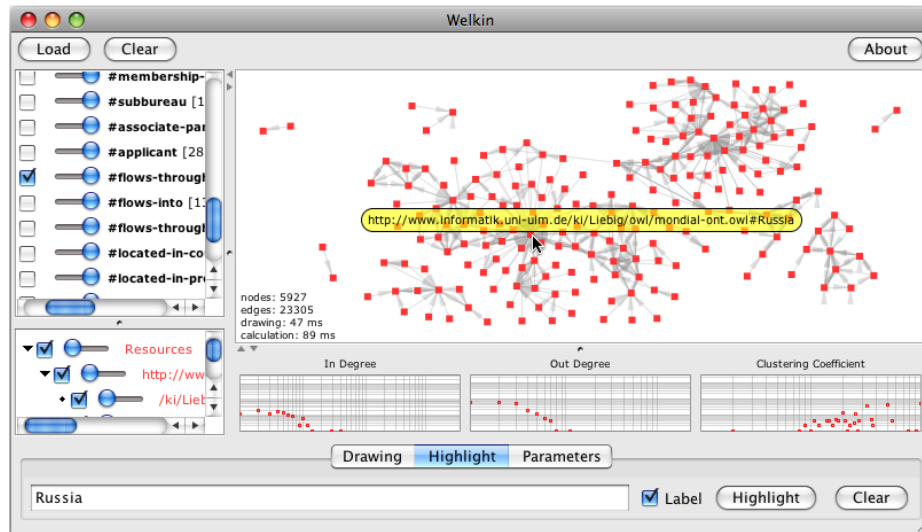

**Figure 2:** Welkin visualizer with network layout between rivers and countries.

prevent the user in being overwhelmed with currently non-relevant information pieces our user-directed interactive exploration strategy allows for focusing on relevant parts of an ontology, or fractions thereof which promise to unveil deeper insights. Initially, one can either start with a user selected entity (e. g. as the result of a query) or with entities belonging to the same concept such as all European capitals. As the visualization and analysis component is integrated into our ONTOTRACK framework the latter task can be carried out by dragging a concept from the schema representation pane on the data analysis pane.

We believe that, from the user's point of view, entities with similar characteristics should build obvious clusters from a visual perspective. These clusters are built either from concept or relationship assertions (implicit or explicit). For instance, in the MONDIAL domain all European capitals and all countries to which these capitals belong to can be pooled within a cluster as shown in Fig. 3. Here, entities are visualized as small filled circles within clusters.

A second dimension of abstraction is used to draw entities in a cluster only if the amount of entities is below a user-definable limit. To easily compare the amount in that cluster its diameter approximates the amount of entities. In addition, the number of fillers are drawn on a cluster as it can be seen in the middle cluster in Fig. 5. Additional detail information for each entity such as an image, information about the population of countries etc. in the MONDIAL domain is provided in an optional scroll-able list as shown on the left hand side

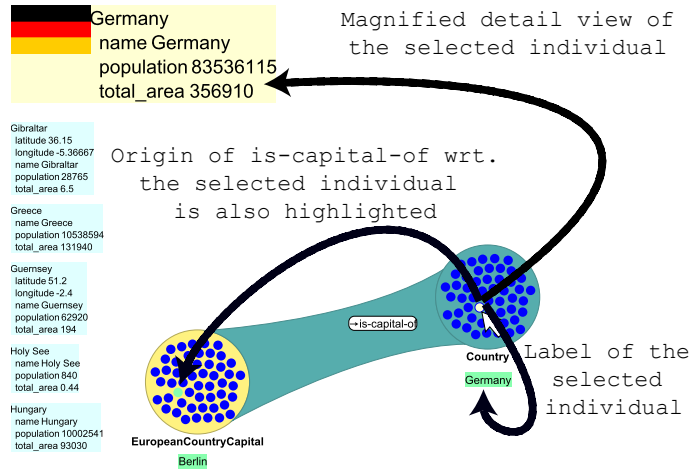

Figure 3: Clustering and club visualization.

of Fig. 3.

Instead of given each relationship between single entities a first-class visual representation and overloading the screen area, entities are grouped by their connecting relationship(s). Relationships are represented by clubs originating from the set of entities which are considered as the relationship’s subject to its objects. This “club visualization” metaphor can be seen in Fig. 3. Here, the club connects the cluster containing all European capitals and all countries to which these capitals belong to, i. e. the cluster sets are connected via the *is-capital-of* relationship. In addition, not only the union of all entities in a cluster can form the origin of a club but also single entities as shown in Fig. 5.

A graphical radial preview menu of related entities grouped by their connecting relationships guides the user through the next exploration steps after clicking on the graphical representation of an entity or a cluster. In order to allow a more flexible exploration, the exploration direction is not limited to the defined direction of the relationship. For instance, the club shown in Fig. 4 represents all countries (right-hand side of the club) that are bordered to European countries (left-hand side). Here, the preview displays different relationships such as *ethnicgroups* or *encompassed* and one can easily grasp that in Armenia there are 3 ethnic groups, or in ontological terms: “Armenia” is related to 3 entities with respect to the relationship *ethnicgroups*. Note that the preview also shows the hierarchical structure of the relationships: *has-city* is a super-relationship of *has-province-capital*. The implied direction of an expansion is denoted by an arrow sign next to the relationship’s label.

Each cluster as well as each (visible) entity can serve as a follow-up point for

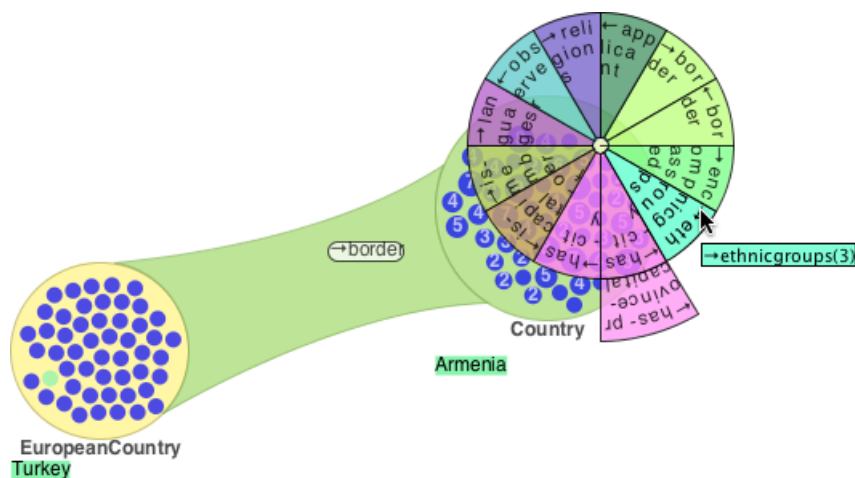

Figure 4: Previews for connected entities grouped by relationships.

further expansions to allow not only parallel expansion paths but also chains of expansions. Note that in a chain of expansion the result cluster of the previous query (i. e. expansion) is used as follow-up point for the next expansion step. For instance, Fig. 5 shows the religions worshiped in countries encompassed by Europe (expansion chain) as well as all continents those countries belong to in parallel.

To easily grasp the related entity/entities to a given one with respect to expanded relationships all entities of the origin of the club and, if further club expansion is available, of the entities of the corresponding relationship wrt. the highlighted entity are recursively highlighted, too. For instance, in Fig. 3 the mouse pointer is hovering over “Germany”. As a result its label is rendered at the bottom of the cluster and because “Berlin” is the only origin of the *is-capital-of* property the corresponding graphical representation is also highlighted and its label also rendered at the bottom of the *EuropeanCountryCapital* cluster.

## 4.2 Visualizing Quantities

Besides qualities, the representation of quantities is another important dimension of visual analytics: we found out that quite a number of queries inherently require to take quantities into account. Even if one can easily grasp how many entities are related to a given one with respect to a specific source by manually counting them, it is more complex to visually answer how many entities in a cluster are related to a specific one within its successor cluster. It is also not enough to count them because it is more a question about the distribution of entities.

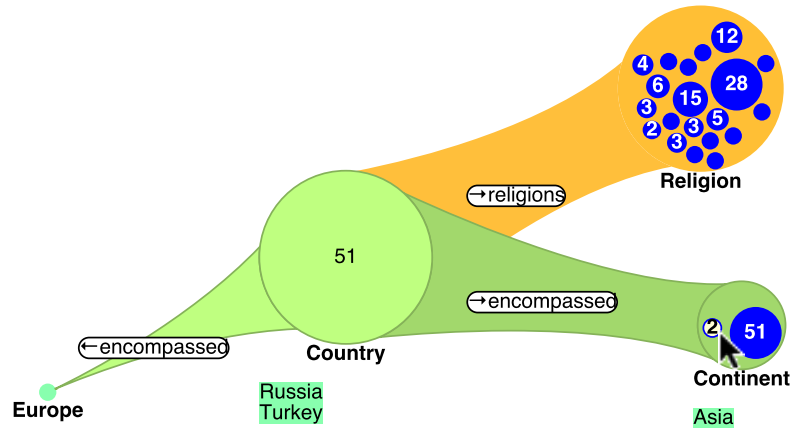
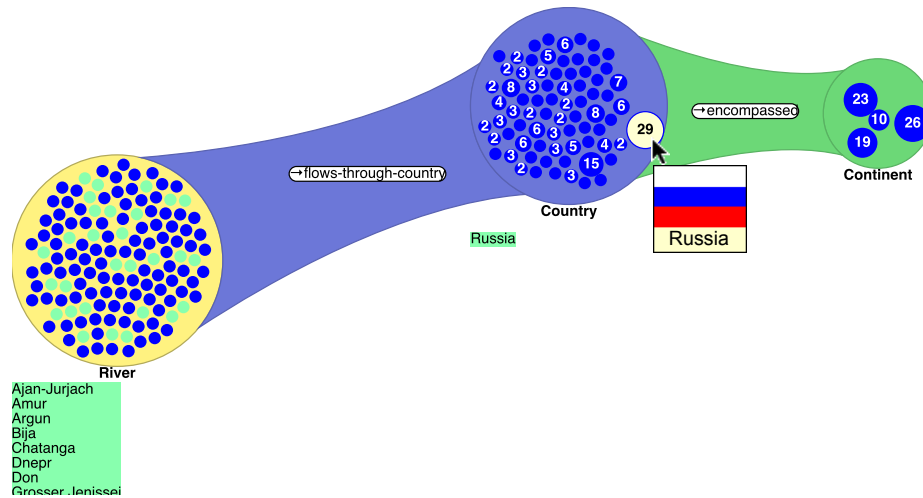

**Figure 5:** Multiple expansion paths.

For instance, to answer the question within the MONDIAL domain which are the countries with the most rivers flowing through, one would start with the cluster representing all rivers. After expanding the club connected via the **flows-through-country** relationship one gets a cluster consisting of all corresponding countries as shown in Fig. 6. Note that one can also recognize the distribution of countries to rivers as well as interactively get the corresponding rivers. Derived from well-known methods from visual analytics we have implemented a simple but powerful solution: the diameters of each country circle scales proportionally with the number of related deserts in the predecessor club. In case that there is more than one single source entity their number is also drawn within the entity circle as shown in Fig. 6. For instance, 29 rivers flow through Russia. One can also figure out on which continents the river flows. By expanding the country cluster with respect to the **encompassed** relationship it shows a follow-up quantity, namely the distribution of those countries to encompassing continents. Consider another example shown in Fig. 5. Here one can easily grasp the distribution of European countries to continents and one can see that two countries, namely Russia and Turkey, belongs also to the Asian continent.

## 5 Conclusion

In this paper we introduced our “club visualization” metaphor which combines established methods from visual exploration and visual analytics in order to discover hidden connections between individuals while not disturbing the user when



**Figure 6:** “Which is the country with the most rivers flowing through?”

exploring large ontologies. A visual feedback about quantities and the outlining of related individuals supplement this visualization in order to enable the user to gain deeper insights into large and heavily interrelated volumes of individuals. Our implementation adds new exploration and understanding possibilities not found in currently available tools. In order to have some fundamental qualitative results concerning average navigation and finding of not-obvious correlation we currently conduct a controlled user study.

## References

- [Auer et al., 2007] Auer, S., Bizer, C., Lehmann, J., Kobilarov, G., Cyganiak, R., and Ives, Z. (2007). DBpedia: A Nucleus for a Web of Open Data. In *Proc. of the 6th International Semantic Web Conference (ISWC 2007)*, pages 722–735. Springer.
- [Keim, 2001] Keim, D. A. (2001). Visual exploration of large data sets. *Communications of the ACM*, 44(8):38–44.
- [Liebig and Noppens, 2005] Liebig, T. and Noppens, O. (2005). ONTOTRACK: A semantic approach for ontology authoring. *Journal of Web Semantics*, 3(2):116 – 131.
- [May, 1999] May, W. (1999). Information extraction and integration with FLORID: The MONDIAL case study. Technical Report 131, Universität Freiburg.
- [Mazzocchi and Ciccarese, 2007] Mazzocchi, S. and Ciccarese, P. (2007). Simile: Welkin. <http://simile.mit.edu/welkin/>.
- [Suchanek et al., 2007] Suchanek, F. M., Kasneci, G., and Weikum, G. (2007). YAGO: A Core of Semantic Knowledge Unifying WordNet and Wikipedia. In *Proc. of the WWW 2007*, pages 697–706, Banff, AL, Canada. ACM Press.
- [Ziegler et al., 2002] Ziegler, J., Kunz, C., Botsch, V., and Schneeberger, J. (2002). Visualizing and exploring large networked information spaces with matrix browser. In *Proc. of the 6th Int. Conf. on Information Visualization (IV’02)*, pages 361–366.

## **Visual Assessment of Heritage Architecture Life Cycles**

**Iwona Dudek, Jean-Yves Blaise**  
(UMR CNRS/MCC 694 MAP, France  
{idu,jyb}@map.archi.fr)

**Abstract:** When studying heritage artefacts, and trying to represent what we know of them, it is important to portray not only key moments in their evolution, but also processes of transformation. In this contribution, we introduce a methodological framework of description of architectural changes, and investigate diagrammatic representations as means to visualize the above mentioned framework. We introduce two types of diagrams (diachrograms that distribute along a time axis transitions and states, variograms that detail the nature of the changes) that should help better understanding, how changes over time affect architecture. The paper also underlines key aspects of data in “historical sciences”: uncertainties, incompleteness, long ranges of time, unevenly distributed physical and temporal stratifications.

**Keywords:** architectural heritage, knowledge modelling, spatio-temporal data

**Categories:** H.3.3, H.5.2, J.5, H.1, H.2.5, H.2.8, H.3.1

### **1 Introduction**

Heritage artefacts, may they be individual edifices or whole sites, are rarely left unchanged by time. Natural or man-related events occur throughout the centuries, resulting in transformations that can introduce minor architectural changes (extension, refurbishment, etc.) or cause important modifications, both in terms of physical appearance and in terms of usage. Ultimately, what we observe (the artefact itself) and know (historical analysis) can be understood as a collection of traces, traces of “all the moments an artefact has been through” during its often complex evolution.

Methods exist that help researchers to state (although with remaining doubts) how an artefact was at time  $t_1$ ,  $t_2$ , ...,  $t_n$ . Broadly speaking, such methods rely on “expert-interpretation” (of observations or archival data) and may include cross-examinations of individual cases. But if one wants to represent and explain the processes that lead from state at time  $t_1$  to states at time  $t_2$ , ...,  $t_n$ , less solutions exist.

As an answer, we investigate visual methods in the analysis of our data set, in order to foster a comparison-enabled, global vision of the artefact’s evolution; whereas traditional architectural representation, by privileging shape modelling, tends to enhance states over changes (see[MhMK ,07]).

In the field of linguistics, F. de Saussure (see [Klinkenberg, 96] or [Barthes, 85]) introduced a distinction between a synchronic approach (where the focus is put on a moment in the evolution of the language) and a diachronic approach (where the focus is put on changes extending through time). We have shown that these notions can be a fruitful methodological base in the field of the architectural heritage [Dudek, 07b]. We consider that for edifices too, there can be a synchronic approach, in which



artefacts are observed as different moments in their life cycles, and a diachronic approach, where the focus is put on a cause-effect analysis.

In this paper, we introduce a methodological framework aiming at describing life cycles in heritage architecture, in what can be seen as a diachronic approach. Focus is put on the way artefacts get transformed, with a grid of notions identifying life cycles as a sum of states and transitions. We then introduce the diagrams that act as visual explanations of the artefact's life cycles and provide some examples on major or minor architecture within the medieval part of the town of Kraków (former capital of Poland, experimental set for this research). Concluding remarks acknowledge the remaining steps we need to take and identify the key benefits expected.

## 2 Objective and context

As shown in [Dudek, 07], cross-examinations of hypothesis about the evolution of heritage artefacts should go beyond a parallel reading of states, and include an analysis and visualisation of causes and effects. Now, when analysing major current research axes, one can observe that synchronic approaches are strongly dominant. (renewed survey techniques, simulation through 3D modelling and VR, GIS-based site management systems are among the most prominent results such approaches). In contrast, we intend to try and apply, in what we view as a visual assessment of architectural changes, E.R Tufte's *first principle for the analysis and presentation of data* : "show comparisons, contrasts, differences" [Tufte, 06].

Little has specifically been done, in the field of the architectural heritage, in order to describe and represent visually the time-chain between successive states or moments in the evolution of artefacts (see [Alkhoven, 93] though). However such approaches can be found outside of the field of the architectural heritage, and in particular in geography (for instance in time-geography [Lenntorp, 03] where the focus is put on time motion. A close example can be found in A. Renolen's graphs [Renolen,97], where changes in land areas are visually assessed through synthetic diagrams. Renolen describes and represents territorial changes: he isolates states and defines events causing changes, a view that we base on. However, his field of application is land areas as seen by a geographer, and the graphs proposed are not directly from being applicable to architectural changes. Among noticeable differences are the 3D nature of artefacts, the transformation processes within a given and stable land area, the reuses and displacements, long-term internments of built structures, uncertainties and incompleteness in the data sets, in the dating of events, etc..

We introduce an analysis of states and transitions that we believe better matches the specificity of heritage architecture. Provided that such an analysis is carried out and properly evaluated, visual methods could allow an in-depth analysis of the data, and could offer an unprecedented view on the global evolution of an artefact. In addition, such graphics could possibly *amplify cognition* [Kienreich, 06] by uncovering patterns of evolution within a site or across sites, underlining uncertainties or exceptions ("documentary gaps"), raising questions about the relative evolution of families of artefacts (urban houses in this or that quarter of the city, churches across the city, etc.). Accordingly, our objective is at the intersection of two issues:

- Describing architectural changes (i.e. a knowledge modelling issue),

- Reasoning visually on and about those changes on real cases (i.e. an infovis issue).

### 3 Method's starting point: a description grid

Our description grid identifies the notion of **artefact** and its possible remaining sub-parts once transformed: a **portion** is a subset of an artefact, it results from its conceptual division into an active part (a **core object**) and an inactive part (a **segment**). We also differentiate its evolution from what we call its life cycles.

- The **evolution of an artefact** is the time slot defined by its creation on one hand (*i.e.* its first appearance), and by its extinction on the other hand (*i.e.* its thorough and irreversible physical removal, including of sub-structures, or its division).
- An **artefact's life cycle** identifies a time slot corresponding to a consistent physical continuum, time slot during which transformations are partial (*i.e.*, the artefact is neither moved nor entirely subdivided into new independent structures).

Given the above definitions, an artefact's evolution may therefore contain several cycles of life. Each life cycle can consist of a number of **states** and **transitions**. **States** are time slots during which no major transformation occurs (or should we say when we have no indication that such transformations occurred). In other words, states identify periods of stability. Each state is preceded and concluded by transitions, time slots during which transformations occur. Often enough, transitions in the field of the architectural heritage may be rather long-lasting **Transitions** indicate that a process of transformation is under way, with specific indications that underline possible causes (for instance, damages caused by fires, a common plague during the medieval period). To sum it up, one can see transitions as causes, and states as consequences.

The proposed description grid identifies seven transitions and states occurring within a life cycle (**abandon, decay, annexation, demolition, modification, secession and segmental anaesthesia**); as well as 8 transitions and states starting/ending a life cycle (**creation, extinction, hibernation, internment, merge, reincarnation, split and translocation**). We hope tags used to denote these transitions and states are illustrative enough to let the reader grab their semantics and will focus on their practical use. Basing on the above framework, two linear diagrammatic representations are proposed, called diachrograms and variograms, combined with one another and with a time scale that matches the artefact's evolution. The next sub-section introduces a brief description of their content and role in reasoning about the artefact.

### 4 Visual methods of analysis

Diachrograms present the evolution of an artefact along a time axis. They are composed of a set of visual indicators representing successive transitions and states combined into life cycles. Their basic components are represented in Fig 1. As will be shown through the examples presented below, visual analysis of a diachrogram combines a global view (density and time distribution of changes) with a local view

(individual features of changes, events and interaction) on one artefact (Figures 1 to 4). It also allows for a comparative view over the collection of artefacts we have studied, with uncertain / lacking data stressed.

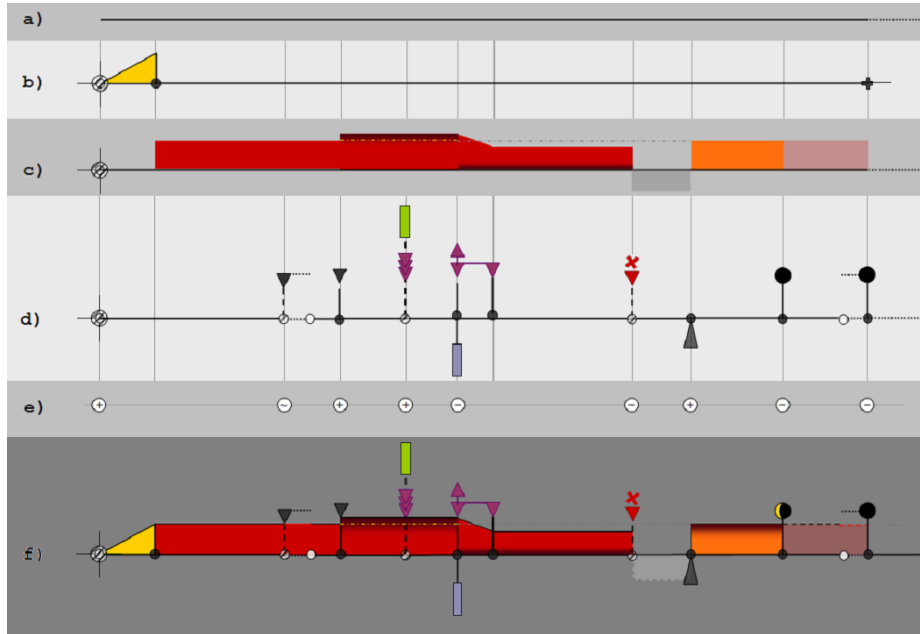

*Figure 1: A diachrogram composition; (a) the time axis; (b) symbols marking start and end of the artefact's evolution; (c) the artefact's state-bar, composed of diversely filled "rectangles" (different colour- different state) with a dash/dot line acting as a reference to the artefact's initial volume; (d) transition-markers, composed of a circle on the time axis and of a vertical line topped by symbols representing transitions. One marker represents a sudden transition, two interrelated show a lasting transition (and its duration). Vertical (green) rectangle(s) above a transition-marker indicate an annexed portion(s) or artefacts, vertical (blue) rectangle(s) below it indicate portions withdrawn from the artefact (e) additional transition qualifiers, stating how the artefact's volume is changed; (f) a combination of the basic components.*

It has to be said that a diachrogram represent an expert's view of the artefact: different analyses of the information gathered on an artefact may lead experts to propose different chronologies - the diachrogram then acts as a comparative tool. The graphic system for the 15 states and transitions identified in section 3 combines 86 transitions markers, 21 state markers, 15 event markers. We do not present each and every combination but show typical examples of use and full-size real-cases.

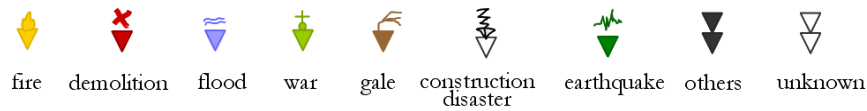

Figure 2: Transition markers, example; the colour of triangles (and sometimes their number) indicates the transition type and a cause of transformation.

Diachrograms underline visually moments when the edifice tends to “get bigger” (as a result of modification by extension or of annexation for instance). They show the level of certainty or lacking information we have on the dating of events (start and end of events). Both transitions and states are represented, with life cycles notified by symmetry along the time axis. Colour coding is used to differentiate irregular states (hibernation, reincarnation, abandon, etc.), as shown on Fig 3.

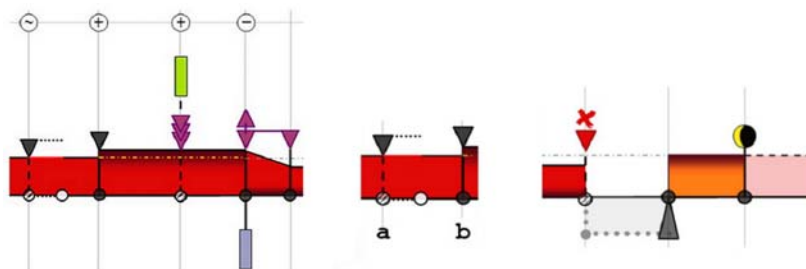

Figure 3: Left - a visual indication of trend (“gets bigger”, “gets smaller”). Middle - the intensity of circle’s filling indicates the level of certainty of the dating (three levels); Here a lasting transition with an uncertain start date and an unknown end date (a), and a sudden, well documented transition (b). Right - alternative colouring used to identify hibernation, reincarnation and abandon states.

In the case of demolition or extinction, an additional pictogram is positioned above the transition visual marker in order to deliver information on the causes of these transitions (of course, when we have enough data to state this: if we have no such data a white filling indicates our ignorance) (cf. Fig 3). A specific triangular shape is positioned below the time axis to mark the reincarnation transition.

When a diachrogram distributes along the time axis transitions and events represented as “typed global events”, a variogram further details the nature of the changes on the artefact. It is used in combination with a diachrogram.

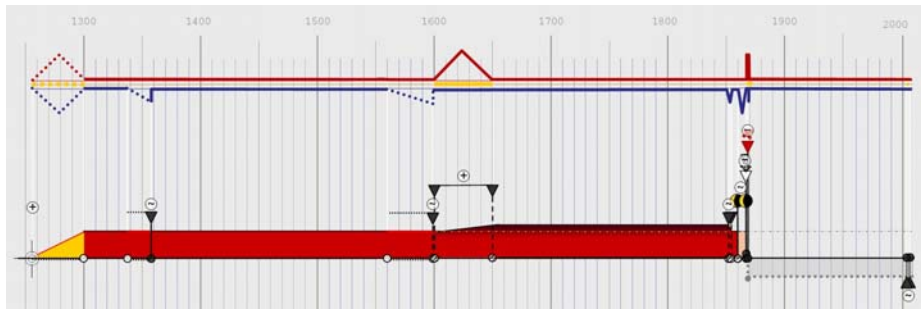

Figure 4: Variogram and diachrogram for Halles aux Draps; note: a) uncertain period of construction (white dating-circles), b) the first and the second exclusively functional modifications (bottom line of the variogram) the duration of which is not established (at least one date of each period is unknown), c) the third morphological and structural transition (construction of a new roof), the duration of the construction period is too long not to be questionable, d) the last group of functional transformations preceding roof collapse and object's demolition (repurchase of an object by a principal owner) and e) underground structures (primal ground-floor) are not demolished, they are hibernating under the ground level, they have been studied (see the last non-invasive intervention of archaeologists) and it is not excluded that it will be brought to live through the reincarnation transition.

A variogram highlights the intensity and duration of changes by combining in a parallel visualisation three aspects:

- morphological changes (formal changes such as stylistic refurbishing, decoration, or changes in surface, volume, etc.),
- structural changes (technical changes such as change of roof material, replacement of sub-elements such as floors, etc.),
- functional changes (significant switches in the way the artefact is used, or change of owners).

Variograms help visual underlining of coinciding changes and stress possible links between these three aspects.

## 5 Implementation and evaluation

This development complements previous works we have carried out on the same field of experimentation - the medieval heart of Kraków (presented for instance in [Dudek, 07] or [Dudek, 05]). Accordingly, the technical platform used is the same:

- a description of artefacts as instances of a hierarchy of classes (in the sense of OOP), with persistence enabled through RDBMS structures,
- outputs (may they be visual outputs – 3D VRML or 2D SVG- or textual outputs –XML) produced by Perl scripts nested in web-enabled pages,
- interfaces produced by Perl scripts either as XHTML (in our first experiments) or as XML/XSLT datasheets,

- graphics produced by Perl scripts either as VRML files or as SVG files.

Both the evolution of architectural and urban elements (341 objects, 885 phases studied) and historical sources used during the investigation (791 sources) have been described. The separation of various types of data allows independent growth of each database or data set, and cumulating information brought by specialists from different domains. In this development, we have privileged dynamic SVG (see [Rathert, 05]); but at this stage only for data visualisation, the interface itself remaining XML/XSLT.

At this stage, evaluation of the disposal as a whole (both the description framework and the graphics) is done by confrontation with experts of the field of experimentation. This is due to the fact that the readability and efficiency assessment of the graphics requires not only a good understanding of historic architecture, but also a deep knowledge of changes that specifically occurred in the city of Kraków (in order to point out lacks, underline inconsistencies or misleading visual signs, etc.). Accordingly we interrogated only four experts, which of course makes our evaluation an indicative one (naturally, after modifications resulting from this evaluation the disposal will be evaluated by widen the audience).

We conducted a two-stage evaluation: direct responses (rating from 1 to 5) collected on eight questions, corresponding to four criteria; and an impact assessment phase during which we identified one by one the consequences yielded by the introduction of the disposal on real cases. Tables 1 and 2 present a brief overview of the results. In short, they show the disposal fosters understanding of changes, usefully uncovers debates, but also has remaining limitations, in particular on time granularity and on showing alternative data interpretation.

readability - (of chronology, states and transitions)	4,85
usefulness in the investigation - (for reasoning, for communication)	5
validity - (ability of the expert to validate elements of the life cycle)	4,83
relevance to the domain - (uncertainty or fuzziness handling, realistic description of artefact changes)	4,25

*Table 1: Direct responses collected from experts (left - criteria, right - average rating).*

Presented diagrams :

---

Foster and uncover new debates on artefact changes among experts, and strongly encourages workgroup discussion.

---

Are an efficient disposal for information exchange - uncovering of inappropriate dating, reviling of differences in understanding of an artefact's evolution (diachrogram was found more efficient than a language (spoken or written).

---

Are effective in comparisons, they allow establishing parallels and underlining inconsistencies inside a collection of artefacts (even for typologically distinct objects).

---

Underline the need of modifications in spatial granularity.

---

Do not permit variations in temporal granularity.

---

They do not take into a consideration the relative importance (in size and significance) of the artefacts.

---

Do not show clearly the moments of uncertain artefact's evolution, when alternative solutions can be proposed.

---

As next step, new possible uses of diachrograms were identified (e.g. sorting out events by type in order to underline for a frequency of fires according to artefact's location, structure, etc.).

---

*Table 2: Impact assessment, with key benefits and remaining limitations.*

## 6 Conclusions

Observing that solutions lack when one wants to recount and sum up the evolution of historic artefacts (lacks in terms of method of description as well as of visualisation), we propose and apply a methodological framework dedicated at a diachronic reading of architectural changes.

Graphics developed are primarily designed to allow the visual assessment of an artefact's life cycles. In addition, following E.R Tufte's observation [Tufte, 01]: *comparisons must be enforced within the scope of the eyespan* - they should provide means for visual comparisons (time  $t_1$  to  $t_n$  of an artefact's evolution, comparative reading of artefacts). The proposed graphics have proved to meet two other principles for the analysis and presentation of data quoted by [Tufte, 06]: *show causality, mechanism, explanation, systematic structure and integrate evidence*. Yet their very nature (structured, commented, time-related diagrams) introduces a strong constraint: diachrograms and variograms are essentially one-dimensional narrative disposals. Accordingly, a truly multivariate analysis of architectural changes has to be accompanied by complementary spatially and dimensionally determined disposals, a direction we have already investigated. Furthermore, going back to Tufte's principles once again, our constant concern in the past years (see for instance [Dudek, 05b], [Dudek, 07]) has been to thoroughly describe the evidence (including by uncertainty "measurement"). Consequently, the development we present complements (and results from) a thorough investigation of artefacts. Diachrograms/variograms should

not be seen as an end, but “yet another mean to perform reasoning tasks” about a data set, and are to be integrated to the global information model described in [Dudek, 05].

Given these precautions, the results we report show that visual thinking can fruitfully apply to the assessment of architectural changes. Provided a relevant knowledge modelling effort is carried out, we believe that the synthetic nature of the graphics proposed helps understanding in a clear-cut manner how changes over time affect architecture, but also underline key aspects of “historical sciences” data: uncertainties, incompleteness, long ranges of time, unevenly distributed physical and temporal stratifications, etc..

## References

- [Alkhoven 93] Alkhoven, P., “The changing image of the city” PHD Thesis, University of Utrecht (1993)
- [Barthes 85] Barthes, R, “L’aventure sémiologique” Seuil, (1985)
- [Dudek 05] Dudek I., et al: “Using abstraction levels in the visual exploitation of a knowledge acquisition process”, Proc. I-KNOW 05, Graz, JUCS, (2005) pp. 543-552
- [Dudek 05b] Dudek I., et al: “From artefact representation to information visualisation: genesis of informative modelling”, Proc. SmartGraphics, LNCS Volume 3638/2005, (2005)
- [Dudek 07] Dudek I., et al: “Visual tools decipher historic artefacts documentation”, Proc. I-KNOW 07, Graz, JUCS, (2007)
- [Dudek 07b] Dudek I., et al: [Terminology of the architectural corpus: material, shape or ideas?] (orig. FR) TIA 2007 Int. conf. Terminology and Artificial intelligence, (2007)
- [Kienreich, 06] Kienreich, W.: “Information and Knowledge Visualisation: an oblique view”, MIA Journal Vol0 Numb.1, (2006)
- [Klinkenberg 96] Klinkenberg, J.M [general semiotics] (orig. FR) De Boeck & Larcier, (1996)
- [Lenntorp 03] Lenntorp, B.: “The drama of real-life in a time-geographic disguise”, In Proc. 6th Théo Quant Meeting, (2003)
- [MhMK 07] Civitas Nostra Cracoviensis – A.D.1650 CD Rom published by the city of Cracow’s Historical Museum – MhMK, (2007)
- [Rathert 05] Rathert, N.A.: “Knowledge visualisation using dynamic SVG Charts”, Geroimenko, V., Chen C (Eds.): Visualizing information using SVG and X3D Springer, (2005)
- [Renolen 97] Renolen, A.: “Conceptual modelling and spatiotemporal information systems : how to model the real world”, In Proc ScanGIS 97, (1997), pp. 35-53
- [Tufte 01] Tufte, E.R.: “Envisioning information”, Graphics Press, Cheshire, (1990-2001)
- [Tufte 06] Tufte, E.R.: “Beautiful evidence”, Graphics Press, Cheshire, (2006)



## Weighted Experts: A Solution for the Spock Data Mining Challenge

Benno Stein and Sven Meyer zu Eissen

(Faculty of Media / Media Systems

Bauhaus University Weimar, Germany

{benno.stein|sven.meyer-zu-eissen}@medien.uni-weimar.de)

**Abstract:** One of the most popular and trend-setting Internet applications is People Search on the World Wide Web. In its most general form, information extraction for persons from unstructured data is extremely challenging, and, we are pretty far away from satisfying solutions. However, current retrieval technology is able to cope with restricted variants of the problem, and this paper deals with such a variant, the so-called *multi document person resolution*. Given is a set of Web documents, and the task is to state for each document pair whether the two documents are talking about the same person or not.

For this problem Spock Inc., Silicon Valley, launched in 2007 a competition offering a grand prize of \$50 000. Task was the person-specific classification of 100 000 Web pages within 4 hours on a standard PC, striving for a maximum  $F$ -Measure. The paper in hand describes the challenge and introduces the technology of the winning team from the Bauhaus University Weimar [see 1].

**Key Words:** person resolution, named entity recognition, supervised cluster analysis

**Category:** H.3.1, H.3.2, I.5.3, M.7

### 1 Person Resolution

If one were able to assort for an arbitrary person  $x$  the entire information that people (including the person him/herself) contributed about  $x$  on the Web, a database of enormous value could be compiled. The benefits of such a database reach from private interests, e.g., when looking for ancient classmates, up to expert search, hiring services, or person-specific advertisement. Under [www.search-engine-index.co.uk/PeopleSearch](http://www.search-engine-index.co.uk/PeopleSearch), for example, various people search services can be found, and, the list is by far not complete. Typically, such services provide some kind of full-text search, possibly restricted to certain categories, person characteristics, or other constraints. If the underlying database is maintained by human editors the quality of the search results will be very high. However, since unstructured data is the fastest growing information source nowadays, there is the question whether such repositories can be built up automatically, or whether the desired information can be extracted in an ad-hoc manner.

Consider in this connection a person query (= the name of a person enclosed in quotation marks) entered into the Google interface, which ideally should yield an assorted result list, gathering all documents of the same person into its own class. In practice the mapping between people and their names is not one-to-one, and hence the search result contains Web pages of different individuals having the same name. Moreover, since an individual can have several Web pages, search results get cluttered, especially when searching for people with common names. The outlined problem can only be addressed with a deeper semantic analysis: Web page content must be interpreted in multiple respects in order to distinguish between different individuals, even if they have the same name. This grouping problem is referred to as “multi document person resolution” [Fleischman and Hovy 2004]; it has recently gained much attention, among others through the Spock Data Mining Challenge.

[1] S. Meyer zu Eissen, B. Stein, St. Becker, Ch. Bräutigam, T. Rüb, and H.-C. Tönnies.

## 1.1 The Spock Data Mining Challenge

“A common problem that we face is that there are many people with the same name. Given that, how do we distinguish a document about Michael Jackson the singer from Michael Jackson the football player? With billions of documents and people on the web, we need to identify and cluster web documents accurately to the people they are related to. Mapping these named entities from documents to the correct person is the essence of the Spock Challenge.”

[<http://challenge.spock.com>]

**Definition 1 Multi Document Person Resolution Problem.** Given are a set of (Web) documents  $D = \{d_1, \dots, d_n\}$ , a set of referents  $R = \{r_1, \dots, r_m\}$ , a set of person names  $Ne = \{ne_1, \dots, ne_l\}$ , and a set of target names  $Nt, Nt \subset Ne$ . Moreover, let  $\nu(d) : D \rightarrow \mathcal{P}(Ne)$  designate a function that returns all person names contained in a document  $d$ . Based on these sets the tuple  $\langle D, R, Ne, Nt, \beta \rangle$  defines a multi document person resolution problem,  $\pi_{pr}$ , if the following conditions hold:

- (1)  $\beta : R \rightarrow Nt$  is a mapping that assigns a target name to each referent.
- (2)  $\forall d \in D : |\nu(d) \cap Nt| = 1$

Finally, we call each function  $\gamma : D \rightarrow R$  a solution of  $\pi_{pr}$ .

*Remarks.* (i) The set of referents  $R$  is the complete set of interesting persons the documents in  $D$  talk about. Related to the quotation above the name Michael Jackson is a target name, and Michael Jackson the singer as well as Michael Jackson the football player are referents. (ii) The fact of being a function qualifies  $\gamma$  as a solution for  $\pi_{pr}$ . Note, however, that a reasonable solution of  $\pi_{pr}$  will fulfill  $\beta(\gamma(d)) \in \nu(d)$  for all  $d \in D$ ; i.e., the referent’s name occurs in its associated documents. (iii) In order to evaluate a solution  $\gamma$  of  $\pi_{pr}$ , a reference classification is needed; the quality of  $\gamma$  can be expressed in terms of the  $F$ -Measure, for example. (iv) A document  $d$  may contain several person names  $\nu(d)$  from which exactly one must be a target name. Of course, the multi document person resolution problem can be defined differently; e.g., one could allow more than one target name per document. The above definition reflects the constraints of the Spock Data Mining Challenge.

Figure 1 shows the benchmark data of the challenge. The training data is a person resolution problem  $\pi_{pr}$  for which the correct classification  $\gamma^*$  is given;  $\gamma^*$  is also designated as ground truth (of the training data) and has an  $F$ -Measure value of 1 per definition. The data set was built by Spock using their Web crawler; observe the imbalanced distributions of the number of referents per target name and the number of documents per referent. The challenge started in April 2007 and ran till December 2007.

## 1.2 Existing Research

Entity resolution exists in several variants, imposing constraints on whether or not training data is available, on whether or not external information sources can be used, or on the maximum time for computing the entity clusters. Some approaches are general enough to work across domains, e.g. the research described in [Pasula et al. 2002;

Number of	Gbyte	
target names	44	
referents	1 101	
training documents	27 000	2.3
test documents	75 000	7.8

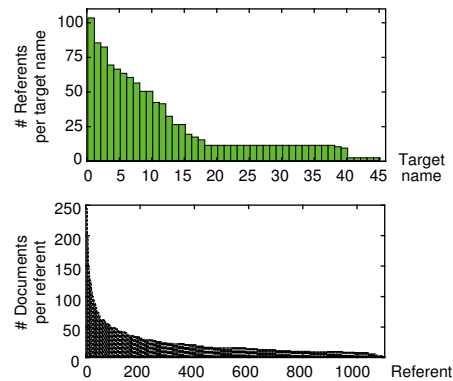

Figure 1: Benchmark data of the Spock Data Mining Challenge (left), the distribution of the referent number over target names (right top), and the distribution of the document number over referents (right bottom).

Daumé III and Marcu 2005; Bhattacharya and Getoor 2006]. The latter two approaches employ latent Dirichlet models for entity resolution, which have been proven to perform well for author name disambiguation, for proper noun coreferencing, and for reference matching. However, these approaches have not been adapted or analyzed for the assorting of Web pages according to referents. [Mann and Yarowsky 2003] propose a clustering approach to disambiguate documents containing target names. Their underlying retrieval models employ term weight features, similarity features based on proper nouns, and similarity features emerging from extracted biographic data like birth year, occupation, and school. They test their approach on a small set of Web pages, which were retrieved from target name queries to Google and manually sorted according to referents. The performance is about 86% accuracy. [Fleischman and Hovy 2004] defined the “multi document person name resolution” problem for which we gave a formalization in Definition 1. The authors propose a set of features to construct a binary classifier that decides whether two documents talk about the same person; the feature set comprises external knowledge acquired from Web search engines. The results of the classification are translated into a similarity graph which then is clustered. The authors experiment with a set of Web pages referring to 31 target names from the ACL dataset. Their results are difficult to interpret since the underlying performance metric is unclear. [Bekkerman and McCallum 2005] use agglomerative clustering to identify referents in Web pages. For evaluation purposes the authors collected Google search results for 12 target names. After result cleaning, the data comprised 1085 Web pages referring to 187 referents. For this small dataset the authors report an  $F$ -Measure of 0.80 with their approach.

From its form the last setting resembles the Spock Data Mining Challenge: Web pages are crawled and made accessible offline, training data is available, and no online requests to Web services are permitted to classify the test data. This scenario is realistic since a service for person name resolution needs to build up a tailored index of relevant pages, avoiding to spend money for frequent search engine queries. Note, however, that the above approaches were evaluated for small and manually cleaned datasets only; it is unclear whether they scale-up in terms of runtime performance and accuracy when given datasets of realistic size. Especially a manual data cleaning is unrealistic when dealing with Gbyte orders of magnitude.

### 1.3 Contributions

Key contribution is the development and implementation of technology to compute a solution  $\gamma$  for the person resolution problem  $\pi_{pr}$  specified in Figure 1, reaching an  $F_\alpha$ -value of 0.40 with  $\alpha = 1/3$  [see 2]. Section 2 introduces the main building blocks of our technology, Section 2.2 reports on selected analysis results, and Section 3 concludes by pointing to different places for improvement. Our solution includes new retrieval models, new ways to combine retrieval models with classification and data mining technology, and deals with realistic orders of magnitudes.

## 2 Elements of Our Analysis Technology

In an open and dynamic environment like the World Wide Web the number of referents  $|R|$  is high and subject to frequent changes. This means that  $\pi_{pr}$  cannot be tackled by a supervised multi-class, single-label classification approach, where the referents  $R$  define the classification scheme according to which the documents  $D$  are classified. Instead,  $\pi_{pr}$  must be understood as a clustering problem: objective is the formation of maximum groups each of which is associated with a single referent. However, if a representative sample of documents along with its correct classification  $\gamma^*$  is given, one can learn from this data, e.g. particular parameters for the clustering algorithm, which in turn can be applied for the clustering of unseen samples. Due to their hybrid nature, clustering algorithms that use knowledge from training data are called “supervised clustering algorithms” [Daumé III and Marcu 2005; Finley and Joachims 2005].

Our approach combines  $o$  retrieval models,  $\mathcal{R}_1, \dots, \mathcal{R}_o$ , to capture the similarity between two documents as an  $o$ -dimensional *meta similarity* vector  $\Sigma$ . In addition, we apply the supervised cluster analysis paradigm: based on the set of meta similarity vectors  $\Sigma_{train}$  along with the correct classification  $\gamma_{train}^*$  for a sample  $D_{train}$ , a document pair classifier  $\delta : \Sigma \rightarrow [0; 1]$  is learned (see Figure 2). Ideally,  $\delta$  will assign to the meta similarity vector  $\Sigma(d_1, d_2)$  a value close to zero if  $d_1$  and  $d_2$  are talking about two different referents—and a value close to one otherwise. In this sense,  $\delta(\Sigma(d_1, d_2))$  can be considered as an estimate for the similarity between the documents  $d_1$  and  $d_2$ ; Figure 3 illustrates for this similarity the desired probability distributions to which a combination of ideal retrieval models and classification technology should adhere.

The steps of the overall analysis process are listed below and illustrated in Figure 2. The process comprises a pre-processing stage for the construction of  $\delta$ , and an application stage, where  $\delta$  is used to compute a similarity graph  $G_\delta$  for the test data, which then is merged.

#### Classifier Construction:

- (1)  $\forall d \in D_{train}$ : compute the retrieval model representations  $\mathbf{d}_{\mathcal{R}}, \mathcal{R} \in \{\mathcal{R}_1, \dots, \mathcal{R}_o\}$ .
- (2)  $\forall d_1 \forall d_2 \in D_{train}$ : compute the model-specific similarity values  $\varphi_{\mathcal{R}}(\mathbf{d}_{1,\mathcal{R}}, \mathbf{d}_{2,\mathcal{R}}), \mathcal{R} \in \{\mathcal{R}_1, \dots, \mathcal{R}_o\}$ . The meta similarity vector  $\Sigma(d_1, d_2), |\Sigma| = o$ , comprises the similarities for  $(d_1, d_2)$ ;  $\Sigma_{train}$  is the set of meta similarity vectors for  $D_{train}$ .

[2] The *prec*- and *rec*-values are computed from the fraction of correctly classified document pairs in relation to all document pairs. In particular,  $F_\alpha = (\alpha+1)/(\frac{\alpha}{prec} + \frac{1}{rec})$ , which puts extra emphasis on the precision.

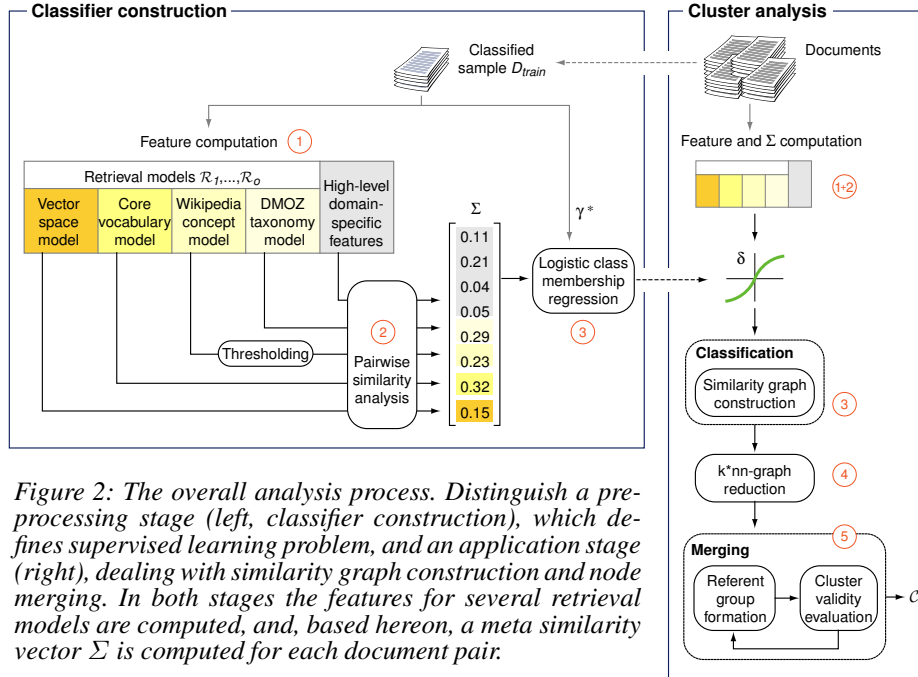

Figure 2: The overall analysis process. Distinguish a pre-processing stage (left, classifier construction), which defines supervised learning problem, and an application stage (right), dealing with similarity graph construction and node merging. In both stages the features for several retrieval models are computed, and, based hereon, a meta similarity vector  $\Sigma$  is computed for each document pair.

- (3) Based on  $\Sigma_{train}$  and  $\gamma_{train}^*$ : learn a document pair classifier  $\delta : \Sigma \rightarrow [0; 1]$ . As classification technology logistic regression was chosen, which provides advantageous characteristics in connection with dichotomous classification problems.

#### Cluster Analysis:

- (1+2)  $\forall d_1 \forall d_2 \in D_{test}$ : compute the meta similarity vectors  $\Sigma(d_1, d_2)$ .  
 (3) Create similarity graph  $G_\delta$  from the estimated document similarities  $\delta(\Sigma(d_1, d_2))$ .  
 (4) Simplify  $G_\delta$  by a mutual  $k$ -nn reduction [Luxburg 2007].  
 (5) Generate multiple, alternative clusterings with the density-based MajorClust algorithm and choose the best clustering by optimizing the internal validity measure *expected density* [Stein and Niggemann 1999; Meyer zu Eissen 2007].

Recall that the challenge conditions allowed the use of external knowledge at the pre-processing stage (e.g. from Wikipedia), for instance to construct the document pair classifier  $\delta$ . Afterwards, within in the classification situation for the test set, no usage of online knowledge was permitted.

## 2.1 The Retrieval Models

Within in the course of the challenge we investigated various retrieval models with respect to their ability to capture knowledge for person resolution: term-based models like the vector space model, text-structure-analyzing models that quantify the text organization, NLP-related models that identify and assess characteristic phrases about named

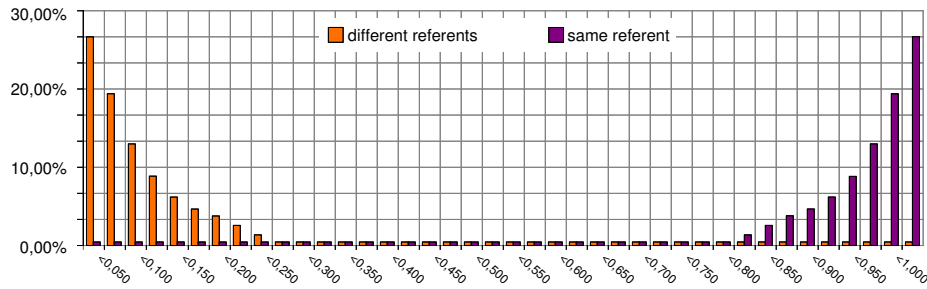

Figure 3: Desired probability distributions for the two classes “different referents” and “same referent” over the range of  $\delta$ , i.e. the similarity interval  $[0; 1]$ . A combination of ideal retrieval models  $\mathcal{R}_1, \dots, \mathcal{R}_o (\Rightarrow \Sigma^*)$  and ideal classification technology ( $\Rightarrow \delta^*$ ) will reproduce these distributions: two documents,  $d_1, d_2$ , talking about two different referents will get with a high probability a similarity assessment  $\delta^*(\Sigma^*(d_1, d_2))$  close to zero. Likewise, two documents talking about the same referent will get with a high probability a similarity assessment close to one.

entities, classification-based models that exploit knowledge compiled within human-edited taxonomies like DMOZ [see 3], and concept-based models such as LSI, pLSI, or ESA, which aim at the identification of hidden connections behind the term surface. After a thorough performance analysis the following models were finally employed:

- $\mathcal{R}_1$ . Vector space model with *tf-idf* term weighting and stopwords removed.
- $\mathcal{R}_2$ . Like  $\mathcal{R}_1$ , but restricted to the enclosing regions of the target name.
- $\mathcal{R}_3$ . Match of top-level DMOZ categories using entire document as feature set.
- $\mathcal{R}_4$ . Like  $\mathcal{R}_3$ , considering the match of top-level plus second level DMOZ categories.
- $\mathcal{R}_5$ . Like  $\mathcal{R}_4$ , but restricted to the enclosing regions of the target name.

This choice does not correspond to the strongest combination to tackle person resolution tasks: in particular, neither NLP-based nor semantically rich models are part of the solution, which is attributed to the runtime constraints that could not be adhered to with the complex retrieval models. The models  $\mathcal{R}_2$  and  $\mathcal{R}_5$  heuristically accomplish a little of the power of a named entity analysis since they introduce extra weight on the terms in the neighborhood of target names. For the retrieval models  $\mathcal{R}_3, \mathcal{R}_4$ , and  $\mathcal{R}_5$  sophisticated multi-class, multi-label classifiers were constructed.

## 2.2 Selected Analysis Results and Discussion

Figure 4 shows the probability distributions generated by the document pair classifier  $\delta$  when the models  $\mathcal{R}_1, \dots, \mathcal{R}_5$  are combined according to an optimum logistic regression of  $\gamma^*$ . The plot may look convincing, but it does not reflect the class imbalance of 25:1 between the document pairs talking about different referents and the document pairs talking about the same referent. When considering this a-priori probability, the averaged precision above a similarity threshold of 0.725 that is generated by  $\delta$  is approximately 0.2. Stated another way: only every fifth edge in the similarity graph  $G_\delta$

[3] DMOZ is a human-edited Web directory, found under <http://www.dmoz.org/>.

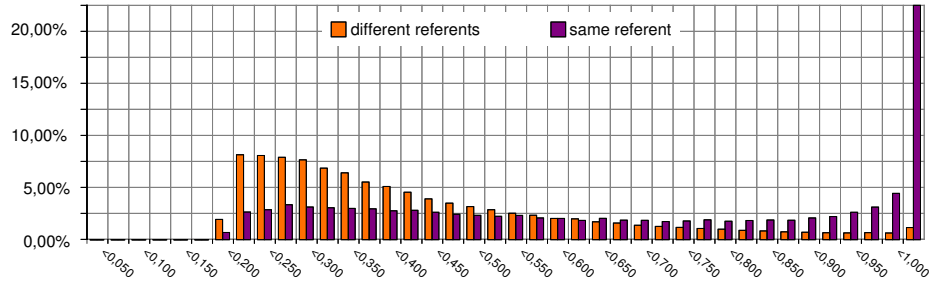

Figure 4: Probability distributions generated by the learned document pair classifier  $\delta$ , based on the optimized combination of the retrieval models  $\mathcal{R}_1, \dots, \mathcal{R}_5$ .

gets a proper weight that reflects the true similarity between its incident documents. Interestingly, this is sufficient to achieve an  $F$ -Measure value of 0.42 after the cluster analysis (see Table 1, right). The rationale for this effect is as follows. Edges between documents of different referents are distributed uniformly over  $G_\delta$ , while edges between documents of the same referent lump together. This characteristic is rooted in the quadratic connection between referent instances (the nodes in  $G_\delta$ ) and the possible relationships between these instances (the edges in  $G_\delta$ ). For a node in  $G_\delta$  one can compute a—what we call—*edge tie factor*, which quantifies this characteristic as the ratio between correct edges on the one hand, and wrong edges that lead to the *same wrong referent* on the other. This factor, which is between 4 and 6 here, reduces the class imbalance accordingly. Altogether, the class imbalance, the edge tie factor, and the achieved probability distributions for  $\delta$  (Figure 4) result in 0.65 as the *effective precision* generated by  $\delta$  above the similarity threshold 0.725.

To capture as much as possible from the  $\delta$  similarity assessments, the graph  $G_\delta$  was abstracted by a mutual  $k$ -nn reduction, and, state-of-the-art cluster analysis technology was applied, including density-based merging, density analysis, and differential probing. Table 1 compiles the recognition results for the Spock Data Mining Challenge that we finally achieved: the left-hand side shows the  $F$ -Measure values for the exclusive use of retrieval models, the right-hand side shows the  $F$ -Measure values when using  $\mathcal{R}_1, \dots, \mathcal{R}_5$  in a combined fashion.

Retrieval model (learning: logistic regression)	$F_\alpha$ -Measure ( $\alpha = 1/3$ )	Learning technology ( $\mathcal{R}_1 + \dots + \mathcal{R}_5$ )	$F_\alpha$ -Measure ( $\alpha = 1/3$ )
$\mathcal{R}_1$ . <i>tf-idf</i>	0.39	logistic regression	0.42
$\mathcal{R}_2$ . <i>tf region</i>	0.32	ensemble cluster analysis	0.40
$\mathcal{R}_3 + \mathcal{R}_4 + \mathcal{R}_5$ . DMOZ all	0.15		
$\mathcal{R}_6$ . ESA Wikipedia persons	0.30		
$\mathcal{R}_7$ . phrase structure analysis	0.17		

Table 1: The achieved recognition results for the Spock Data Mining Challenge, depending on the retrieval models and the employed learning technology. Due to performance reasons,  $\mathcal{R}_6$  and  $\mathcal{R}_7$  were excluded from the final solution.

In terms of the  $F$ -Measure the difference between a retrieval model combination and their exclusive use appears small. The main benefit of applying multiple models

lies in the improved generalization capability, which could be verified on smaller test sets. Likewise, though the ensemble cluster analysis behaves inferior compared to the logistic regression (see Table 1, right), it has the potential to generalize better when using knowledge-based combination rules.

### 3 Room for Improvements

From our point of view the most interesting results of the contribution relate to the combination of different retrieval models, and the concept of effective precision. With respect to the former we can clearly state that the full potential has not been tapped; the following promising retrieval models are not part of our solution:

- explicit semantic analysis, ESA [Gabrilovich and Markovitch 2007]
- genre-enabling models [Stein and Meyer zu Eissen 2008]
- named-entity and shallow-parsing models based on a phrase structure analysis

Further room for improvement relates to the field of graph abstraction, where the use of flexible and node-depending thresholds should be investigated.

### References

- [Bekkerman and McCallum 2005] Bekkerman, R., and McCallum, A.: Disambiguating Web appearances of people in a social network. In *WWW '05: Proc. 14th international conference on World Wide Web*, pp. 463-470, New York, NY, USA, 2005. ACM. ISBN 1-59593-046-9.
- [Bhattacharya and Getoor] Bhattacharya, I., and Getoor, L.: A Latent Dirichlet Model for Un-supervised Entity Resolution. In Joydeep Ghosh, Diane Lambert, David B. Skillicorn, and Jaideep Srivastava, editors, *SDM*, 2006. ISBN 0-89871-611-X.
- [Daumé III and Marcu 2005] Daumé III, H., and Marcu, D.: A Bayesian model for supervised clustering with the Dirichlet process prior. *Journal of Machine Learning Research*, 6:1551-1577, September 2005. URL <http://pub.ia13.name/#daume05dpscm>.
- [Finley and Joachims 2005] Finley, F., and Joachims, T.: Supervised clustering with support vector machines. In *ICML '05: Proc. 22nd International Conference on Machine Learning*, pp. 217-224, New York, NY, USA, 2005. ACM. ISBN 1-59593-180-5. doi: <http://doi.acm.org/10.1145/1102351.1102379>.
- [Fleischman and Hovy 2004] Fleischman, M. B., and Hovy, E.: Multi-Document Person Name Resolution. In *Proc. ACL '04 Workshop on Reference Resolution and its Applications*, 2004.
- [Gabrilovich and Markovitch 2007] Gabrilovich, E., and Markovitch, S.: Computing semantic relatedness using wikipedia-based explicit semantic analysis. In *Proc. 20th International Joint Conference for Artificial Intelligence*, Hyderabad, India, 2007.
- [Luxburg 2007] Luxburg, U.: A tutorial on spectral clustering. *Statistics and Computing*, 17(4): 395-416, 2007. ISSN 0960-3174. doi: <http://dx.doi.org/10.1007/s11222-007-9033-z>.
- [Mann and Yarowsky 2003] Mann, G. S., and Yarowsky, D.: Unsupervised personal name disambiguation. In *Proc. seventh conference on Natural language learning at HLT-NAACL 2003*, pp. 33-40, Morristown, NJ, USA, 2003. Association for Computational Linguistics.
- [Meyer zu Eissen 2007] Meyer zu Eissen, S.: *On Information Need and Categorizing Search*. Dissertation, University of Paderborn, Feb. 2007.
- [Pasula et al. 2002] Pasula, H., Marthi, B., Milch, B., Russell, S. J., and Shpitser, I.: Identity Uncertainty and Citation Matching. In *Advances in Neural Information Processing Systems (NIPS)*, pp. 1401-1408, 2002.
- [Stein and Meyer zu Eissen 2008] Stein, B., and Meyer zu Eissen, S.: Retrieval Models for Genre Classification. *Scandinavian Journal of Information Systems*, to appear, July 2008.
- [Stein and Niggemann 1999] Stein, B., and Niggemann, O.: On the Nature of Structure and its Identification. *Graph-Theoretic Concepts in Computer Science*, volume 1665 LNCS of *Lecture Notes in Computer Science*, pp. 122-134. Springer, June 1999. ISBN 3-540-66731-8.



## **Special Track on Knowledge Services KS 2008**

**Stefanie Lindstaedt**

(Know-Center Graz, Austria  
and Knowledge Management Institute, Graz University of Technology, Austria  
{slind}@know-center.at)

**Ronald Maier**

(Innsbruck University School of Management, Information Systems, Austria,  
ronald.maier@uibk.ac.at)

**Viktoria Pammer, Peter Scheir, Nicolas Weber**

(Knowledge Management Institute, Graz University of Technology, Austria  
and Know-Center Graz, Austria,  
{vpammer,pscheir,nweber}@know-center.at)

The knowledge management system of the future balances the needs of individual knowledge workers for flexibility with the needs of communities for interconnectivity and the needs of organizations for standardization. Knowledge services have the potential to support (and incrementally merge) two roles within organizations and communities: On the one hand this concerns the knowledge worker who wants support for executing her current task efficiently and to advance her competencies over time. On the other hand the knowledge engineer needs support for the identification, modelling and standardization of community knowledge patterns (e.g. social networks) and organizational knowledge structures (e.g. domain ontologies).

One challenge to be tackled here is the identification of relevant knowledge services which will prove helpful to the individual knowledge workers and engineers. Research into the characteristics of knowledge and community work is necessary to inform the design of knowledge services and to ensure their usefulness and usability. A knowledge worker will then be able to dynamically integrate contextualized knowledge services such as recommendation of knowledge artefacts and learning resources, community awareness and collaboration support into her work environment. Corollary community knowledge services such as automatic process detection and collaborative modelling services will speed up evolution of community and organizational knowledge structures. Further services supporting design and development, analysis and maintenance of knowledge services are desirable, if such systems shall scale and shall stay manageable over time. This includes e.g., the underlying knowledge structures, organisational and technological infrastructure as well as trust in and reputation of the sources delivering the services.

Another challenge involves the question which knowledge management system functionalities lend themselves for service encapsulation. Encapsulation of program functionality into services and the interaction of individual services in the form of service oriented architectures are active fields of research. Organisational processes or

individual workflows require (dynamic) service orchestration. Automatic identification of appropriate services for a given task requires machine-intelligible web service descriptions (semantic annotations). For application it is interesting to know how such knowledge services can be integrated into pre-existing IT-landscapes within an organisation, or which requirements knowledge services themselves have. Some challenges have already been addressed in academia and industry, and we want to continue the discussion of technical issues and profit from existing results and experiences.

Based on the reviewers' reports, 4 from 9 submitted contributions were accepted for presentation within the special track and for publication within the conference proceedings. The accepted contributions range from concrete instantiation of knowledge service on the one hand to conceptual frameworks and use cases for knowledge service on the other hand:

Bahrs, Meuthrath and Peters present Information Retrieval Services for heterogeneous information spaces. The services facilitate federated search engines that use case-based reasoning for reranking of search results.

Ong, Riss, Grebner and Du present a Semantic Task Management Framework providing a set of task services on the desktop with adaptable semantic foundation.

Woitsch and Leutgeb present a Use-Case Scenario of a Service-Based Knowledge Management Approach, currently applied in the EU-funded integrated project BREIN.

Schmidt, Hinkelmann, Lindstaedt, Ley, Mayer and Riss present the Conceptual Foundations for a Service-Oriented Knowledge & Learning Architecture to be realized within the EU-funded integrated project MATURE.

## Organizers

- Stefanie Lindstaedt, Know-Center Graz and Graz University of Technology (Austria)
- Ronald Maier, Innsbruck University School of Management (Austria)
- Viktoria Pammer, Graz University of Technology and Know-Center Graz (Austria)
- Peter Scheir, University of Technology and Know-Center Graz (Austria)
- Nicolas Weber, Graz University of Technology and Know-Center Graz (Austria)

## Program Committee

- Simone Braun, Forschungszentrum Informatik (Germany)
- Markus Bick, Europäische Wirtschaftshochschule Berlin (Germany)
- Knut Hinkelmann, Universities of Applied Sciences FHNW (Switzerland)
- Christoph Kiefer, University of Zürich (Switzerland)
- Werner Klieber, Know-Center Graz (Austria)
- Franz Lehner, University of Passau (Germany)
- Gregoris Mentzas, University of Athens (Greece)

- Claudia Müller, Universität Potsdam (Germany)
- Ulrich Remus, University of Erlangen-Nuremberg (Germany)
- Johannes Sametinger, University of Linz (Austria)
- York Sure, SAP Research (Germany)

## **Conceptual Foundations for a Service-Oriented Knowledge & Learning Architecture: Supporting Content, Process, and Ontology Maturing**

**Andreas Schmidt**

(FZI Research Center for Information Technologies, Germany  
andreas.schmidt@fzi.de)

**Knut Hinkelmann**

(University of Applied Sciences Northwestern Switzerland  
knut.hinkelmann@fhnw.ch)

**Stefanie Lindstaedt**

(Graz University of Technology and Know-Center, Austria  
slind@know-center.at)

**Tobias Ley**

(Graz University of Technology and Know-Center, Austria  
tley@know-center.at)

**Ronald Maier**

(University of Innsbruck, Information Systems, Austria  
ronald.maier@uibk.ac.at)

**Uwe Riss**

(SAP AG, Germany  
uwe.riss@sap.com)

**Abstract:** The knowledge maturing model views learning activities as embedded into, interwoven with, and even indistinguishable from everyday work processes. Learning is understood as an inherently social and collaborative activity. The Knowledge Maturing Process Model structures this process into five phases: expressing ideas, distributing in communities, formalizing, ad-hoc learning and standardization. It is applicable not only for content but also to process knowledge and semantics. In the MATURE IP two toolsets will be developed that support the maturing process: a personal learning environment and an organisation learning environment integrating the levels of individuals, communities and organisation. The development is guided by the SER theory of seeding, evolutionary growth and reseeding and is based on generally applicable maturing services.

**Keywords:** content, e-Learning, knowledge management, maturity, ontology, process, service, service-oriented architecture

**Categories:** L.3.4 - Learning Processes; L.3.6 - Technology Enhanced Learning; L.1.0 - Knowledge Construction/Representation

## 1 Introduction

In a world of constant change, enterprises need to become increasingly agile in order to successfully compete. They need to adapt to changes, deliver new or improved product and service offers. To do so, they need to leverage their employees' creativity and hands-on experience, improve the sharing of knowledge within the enterprise (and often also across its borders), and combine all this with a new form of organizational guidance. To support these activities, we need to move away from systems conceived and operated in a top-down way (like traditional learning or knowledge management systems). Rather, we need a balance of bottom-up and top-down development of systems supporting learning, knowledge handling and innovation in businesses and organisations. The aim is to bring together Web 2.0-style engagement and user empowerment with the efficiency of organizations in exploiting knowledge on a larger scale. Within the MATURE IP (<http://mature-ip.eu>), the goal is to develop two toolsets:

- *a personal learning environment* (Attwell, 2007), consisting of work-integrated, personalized tools for communicating, collaborating, structuring, reflecting, and awareness building. The individual learner should be able to easily combine these tools and readily interoperate with others' personal learning environments;
- *an organizational learning environment*, giving the organization (or better its representatives) the opportunity to analyze bottom-up activities within the sum of individual PLEs. The results of these analyses should promote the consolidation of such activities towards organizational goals, enable the breeding of strategically important communities, and help enriching existing knowledge resources so that they can be readily reused as learning objects.

Such toolsets must be flexible and easily extensible, which calls for an infrastructure providing reusable knowledge services. But how should such a service infrastructure look like? What are conceptual foundations for a service-oriented knowledge architecture that could help to reach the goals outlined above?

In this paper, we present an approach to conceptualizing knowledge services based on the knowledge maturing model (Maier & Schmidt, 2007). This model helps to understand the 'flow' of knowledge and its barriers. We extend this by differentiating between knowledge assets of varying degrees of maturity (section 2). We then derive intervention strategies from the SER model (section 3) that form the basis for maturing (support) services (section 4).

## 2 Knowledge Maturing

The knowledge maturing model views learning activities as embedded into, interwoven with, and even indistinguishable from everyday work processes. Learning is understood as a social and collaborative activity, in which individual learning processes are interdependent and dynamically interlinked with each other: the output of one learning process is input to the next. If we have a look at this phenomenon from a macroscopic perspective, we can observe that knowledge is continuously repackaged, enriched, shared, reconstructed, translated and integrated etc. across

different interlinked individual learning processes. During this process knowledge becomes less contextualized, more explicitly linked, easier to communicate, in short: it matures. The **knowledge maturing process** model structures this process into five phases (based on experiences from several practical cases as well as a comprehensive empirical study, [Schmidt 2005, Maier 2007, Maier and Schmidt 2007]):

- **Expressing ideas.** New ideas are developed by individuals from personal experiences or in highly informal discussions. The knowledge is subjective and deeply embedded within the context of the originator. The vocabulary is vague and often restricted to the person expressing the idea.
- **Distributing in communities.** This phase accomplishes the development of common terminology shared among community members, e.g. in discussion forum entries, blog postings or wikis.
- **Formalizing.** Artefacts created in the preceding two phases are inherently unstructured and still highly subjective and embedded in the context of the community. In this phase, purpose-driven structured documents are created, e.g. project reports or design documents or process models in which knowledge is 'desubjectified' and the context is made explicit.
- **Ad-hoc learning.** Documents produced in the preceding phase are not well suited as learning material because no didactical considerations were taken into account. Now the topic is refined to improve comprehensibility in order to ease its consumption or re-use. The material is ideally prepared in a pedagogically sound way, enabling broader dissemination, e.g. service instructions or manuals.
- **Standardization.** The ultimate maturity phase puts together individual learning objects to cover a broader subject area. Thus, the subject area becomes teachable to novices. Tests and certificates confirm that participants of formal training achieved a certain degree of proficiency.

This maturing process is most intuitively recognized in the case of 'content objects' (knowledge represented in the form of documents, drawings, etc.). However, it also applies to other types of knowledge representations vital for operating and developing any kind of organisation: namely processes and semantics [Riss 2005]:

- **Contents** provide a static picture of the world and are probably the best managed type of knowledge asset. The term knowledge asset points towards a value-oriented perspective on knowledge elements (business value) suggesting the importance of knowledge for the functioning of an organisation's business processes. It can take the form of notes, contributions and threads, protocols, lessons learnt, learning objects, courses, etc.
- **Processes.** This type of knowledge asset is more related to the dynamic aspect of the organisation. Large organisations already support this by developing business process models and workflows. Taking into account that organisational learning processes are much more agile and the costs of modelling approaches are considerable, a more suitable approach is to enable recording and sharing of individual work practices. Processes can take the form of e.g. individual task lists and routines, task patterns, good practices, best practices, work flows or standard operating procedures.
- **Semantics.** This type of knowledge asset is probably the least visible within organizations. Semantics connects the different assets and supports the

individual learning processes by providing the basis for mutual understanding. Without semantic integration, grassroots approaches encouraging people to contribute their individual views, experiences and insights would get stuck in misinterpretations and lengthy negotiation processes. These knowledge assets can take the form of tag clouds and emerging folksonomies, folder structures, competence models, local or global enterprise ontologies.

These three knowledge asset types – and thus the three strands of maturing – are closely interwoven and they depend on each other in various respects. Contents and processes require semantics to become communicable. Therefore, semantics is the fundament for every community-based approach and fosters collaboration between individual knowledge workers. Without process integration, semantics and contents are not directly applicable to work procedures so that additional transformation efforts by the knowledge workers are required. More mature content allows a worker to deal with the high complexity and variability of knowledge-intensive processes and adapt to unpredictable situations [Feldkamp, Hinkelmann & Thönssen 2007]. Finally, contents are required to explicate semantics and processes so that these are comprehensible to knowledge workers with different backgrounds. While semantics and processes focus on the actual doing, contents aim at understanding and reflection.

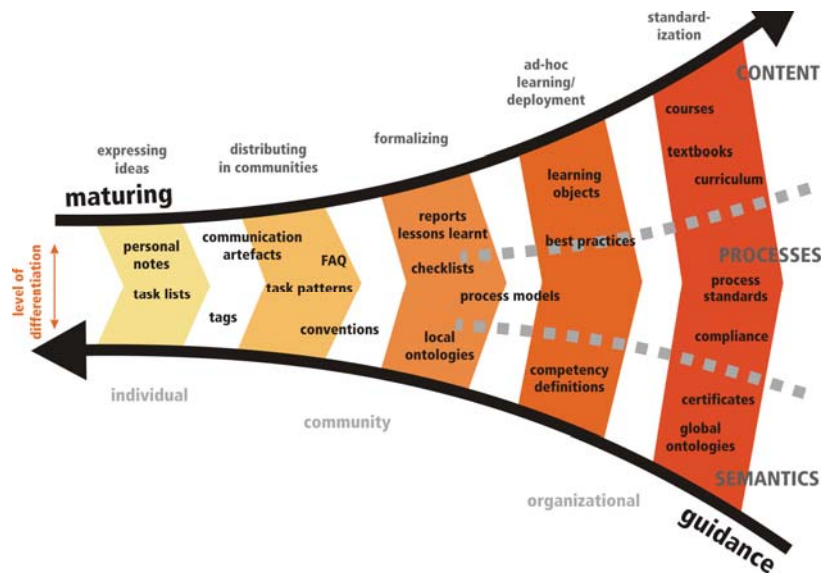

Figure 1: Knowledge Maturing Process Model.

[Figure 1] depicts the described situation schematically. Knowledge asset types are not well differentiated in the early maturing phases; notes can contain content, process, and semantic aspects, sometimes all at the same time. Only with a deepened understanding, this differentiation can take place. This corresponds with a decrease in abundance: while there are many notes and communication artefacts at the beginning of the maturing process, formal training materials are rather scarce at its end. It also

shows that the maturing process is accompanied by a process of organisational guidance that supports the identification of significant emerging topics and their transformation to more mature forms of knowledge.

As the process of guidance already indicates, the development should not be misunderstood as a continuous linear process. On the contrary, **maturing is made up of a complex pattern of individual steps**. Not all knowledge assets are developed up to the ultimate maturity phase, some of them end up in a stalemate or are discarded; others are combined with other assets at various maturity levels, or split up into more differentiated assets. What we observe is an **evolution** of knowledge assets.

### 3 Seeding –Evolutionary Growth – Reseeding

A closer look at how individual maturing phases actually take place reveals that the theory of **Seeding, Evolutionary Growth and Reseeding**, (SER) [Fischer et al. 2001] is applicable here. The SER model describes how complex systems evolve out of an initial seed (units, structure, and capabilities) and through the use of combination, analysis and change tools by many diverse users. Community activity leads to evolutionary, undirected (and often confusing) growth of the original units, structures and capabilities. At some point in time, the evolved system needs to be reseeded in order to be kept manageable. This reseeded can happen in a form of consolidation and negotiation processes in which the variety of units, structures, and capabilities are pruned and consolidated.

[Figure 2] illustrates the application of the SER model to the maturing model. The main hypothesis is that seeding, evolutionary growth and reseeded can be applied to each maturing phase. Seeding initiates the maturing process and leads into the evolutionary growth phase. At the end of each maturity process phase, a decision has to be made. One alternative is to reseed the current maturity step. This would involve cleaning out the current knowledge base (the collection of relevant knowledge assets), selecting a portion of the knowledge elements and re-starting the maturing process on the same maturity level. This reseeded implements the guidance direction (see [Figure 1]) by aligning knowledge assets with objectives and process requirements. If a portion of the knowledge base is considered sufficiently mature, it is selected and used to seed a maturity process at a higher level of maturity.

For an example consider the maturity phase ‘distributing in communities’. First a community ‘space’ is seeded with the initial idea or topic. This involves creating an initial knowledge structure together with its knowledge units and their capabilities and characteristics. In order to enable evolutionary growth this community environment needs to be equipped with means (tools) for combination, analysis, and change of the structures and the units themselves. Such tools allow the diverse users to combine knowledge units to build (increasingly complex) knowledge structures and to change the knowledge units themselves according to their needs. Analysis tools enable the community to monitor and guide its activities. If the development of the topic reaches a certain level, the decision whether to take the topic to the level of formalizing has to be made. If the development of the topic stagnates, reseeded might be an option. This includes pruning the current knowledge base, introducing new ideas, knowledge elements or people into the community or changing the topic.



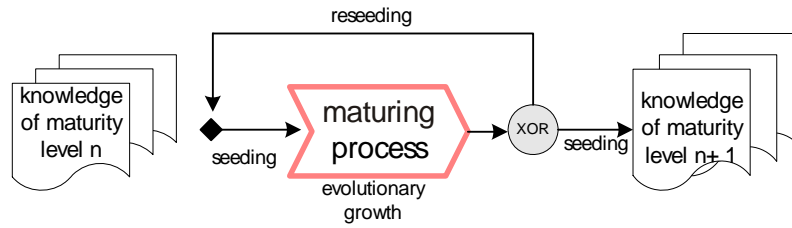

Figure 2: The SER model guides maturity processes.

### 4 Maturing Services

If we consider the knowledge asset types that appear in [Figure 1] we find that they are supported by a variety of mainly independent tools divided both along the levels of interaction and along the types of knowledge asset. The independence of these tools reflects the existing gaps in the support for maturing processes as it exists so far.

Dimensions Levels of Interaction → Knowledge Assets ↓	Individual	Community	Organisation
Contents	contacts, notes, drafts	wiki pages, blogs	manufactured contents
Semantics	tags, conventions	local ontologies	global ontologies
Processes	tasks	task patterns	process models

Table 1: Separation of knowledge asset types within different tools.

To overcome the described separations, we need to interconnect tools which manage the different knowledge assets and provide services that support the knowledge flow between the different levels [Table 1]. We refer to such tool connections and services as **maturing services**, since they support the maturing process.

Generally, a service is an abstract resource that represents a capability of performing tasks that form a coherent functionality from the point of view of providers entities and requesters entities [W3C 2004]. It consists of a contract, interfaces as well as implementation and has a distinctive functional meaning typically reflecting some high-level business concept covering data and business logic [Krafzig, Banke and Slama 2005, 57-59]. In our case, the business concepts represented by maturing services are the knowledge asset types identified above, i.e. the contents of varying degrees of maturity, the maturing and guidance processes as well as the various types of semantics. Consequently, maturing services are needed that help knowledge workers to handle these knowledge assets. Whereas the technical definition of services is supported by a set of standards (such as Web services), it is the conceptual part (i.e. defining types of services that are useful) that is currently lacking. But exactly this conceptual part matters most when organisations attempt to profit from the promised benefits of service-oriented architectures. In the following, we introduce

three maturing service types which we will consider in the future, and give an example of one intelligent service which we have implemented for a collaborative tagging environment.

#### 4.1 Maturing Service Types

According to the SER model we distinguish between three types of maturing services:

**Seeding services** enable the user to set up and initialize knowledge units and structures within a community. Such services could include the initialization of an associative network (AN) based on document similarities or the initialization of user models based on social network analysis (SNA). During seeding specific similarity measures and characteristics which the SNA algorithm operates upon will be determined. Seeding services also include functionalities to use the instantiated structures. In our example these would include services that recommend relevant documents and persons based on the AN or the user model. An example will be presented in the next section.

**Growth services** allow users to add new knowledge units (e.g. documents or users), to adapt their characteristics (e.g. the users' competencies) to provide comments and to change the system behaviour. Growth services are based on the Web2.0 paradigm in which users can produce their own content and which utilizes collective usage data and user feedback to improve the system's performance. In our example, growth services include mechanisms to change weights within the AN and mechanisms to infer user characteristics based on their activities.

**Reseeding services** allow the user to analyse and visualize the collective activities of the community, negotiate between conceptualizations of different users and finally (and most importantly) to change the underlying structures and functionalities. These reseeded services will go beyond the Web2.0 paradigm by enabling users to not only add and change content but also to change the underlying structure and functionality of the evolving knowledge system. In our example this could include adapting similarity measures and changing user characteristics.

#### 4.2 Seeding and Growth in a Collaborative Tagging Environment

Tagging resources can be seen as a first step of providing semantic descriptions for these resources. The results of such activity are knowledge assets (tags) which are used on an individual level (see [Table 1]). Collaborative tagging environments (such as <http://www.flickr.com> or <http://www.del.icio.us>) make it possible to share these in a community setting. How could services be designed to facilitate the seeding and evolutionary growth in the community setting.

As a basis of our maturing services we use cognitive models that have been extensively used for modelling individual cognitive processes of knowledge encoding, representation and retrieval. An example here is the declarative knowledge module in ACT-R [Anderson et al. 2004] which models knowledge as an associative network. We then seek to transfer these models to a distributed community setting where several actors and shared artefacts are involved. So in fact what we are aiming to do is to describe knowledge maturing in an organisation as a distributed cognitive process which is based on a knowledge representation that describes the knowledge of a whole community .

In the example of the collaborative tagging environment, the folksonomy (shared tags) is modelled as an associative network using tag co-occurrences [e.g. Steels 2006]. Tags are modelled as nodes in a network where co-occurrence with other tags determines the associations, or the weights on the edges. We have modelled a folksonomy in this way for a flickr data set [Pammer, Ley and Lindstaedt 2008].

After an appropriate model has been established (and evaluated for its validity) intelligent services can be built upon it by simulating cognitive processes on a community level, such as knowledge retrieval. In the flickr example, the service we implemented was to recommend tags when users uploaded new pictures. This service simulates tag associations in a distributed cognitive structure. In another case, we employ spreading activation mechanisms for these processes (which are also implemented in the ACT-R architecture) [Scheir, Ghidini and Lindstaedt 2007]. First experiments have shown that this service reduces the number of tags people use as they make use of existing tags. In our view this helps to emerge a shared understanding, as the system grows evolutionary.

## 5 Conclusions

In this contribution we have introduced our current understanding of the knowledge maturing process. In the MATURE project we will study in detail how this maturing process currently takes place within organizations and communities. Based on the insights we gain we will develop maturing services which will support knowledge maturing along the knowledge asset type dimension (supporting maturing of contents, semantics, and processes tightly interwoven) and providing integrated support for the whole maturing process from individual learning to organizational learning.

These services enable the creation of learning environments as a set of loosely coupled tools which can be integrated based on the emerging mashup paradigm. This brings learning & maturing support to the end user and creates a flexible and dynamic knowledge and learning architecture.

### Acknowledgements

This work has been partially funded under grant 216346 in the IST work programme of the European Community. The Know-Center is funded within the Austrian COMET Program - Competence Centers for Excellent Technologies - under the auspices of the Austrian Ministry of Transport, Innovation and Technology, the Austrian Ministry of Economics and Labor and by the State of Styria.

### References

- [Anderson et al. 2004] Anderson, J. R., Bothell, D., Byrne, M. D., Douglass, S., Lebiere, C., & Qin, Y. (2004). *An integrated theory of the mind*. Psychological Review, 111 (4), 1036–1060.
- [Attwell 2007] Attwell, Graham (2007). *The Personal Learning Environments - the future of eLearning?* eLearning Papers, vol. 2 no. 1. ISSN 1887-1542.

- [Braun et al. 2007] Braun, S.; Schmidt, A.; Walter, A.; Nagypal, G.; Zacharias, V. (2007): *Ontology Maturing: A Collaborative Web 2.0 Approach to Ontology Engineering*, WWW 07 Workshop on Social and Collaborative Construction of Structured Knowledge, Banff, Canada.
- [Feldkamp, Hinkelmann and Thönssen. 2007] Feldkamp, D., Hinkelmann, K., Thönssen, B. (2007): *KISS- Knowledge-Intensive Service Support: An Approach for Agile Process Management*. In: Paschke, A., Biletskiy, Y. (Eds.): *Advances In Rule Interchange and Applications*, International Symposium RuleML 2007, Springer-Verlag, pp. 25-38
- [Fischer et al. 2001] Fischer, G.; Grudin, J.; McCall, R.; Ostwald, J.; Redmiles, D.; Reeves, B.; Shipman, F. (2001): *Seeding, Evolutionary Growth and Reseeding: The Incremental Development of Collaborative Design Environments*, In: Olson, G.; Malone, T. and Smith, J. (eds.): *Coordination Theory and Collaboration Technology*. Lawrence Erlbaum Associates.
- [Krafzig, Banke and Slama 2005] Krafzig, D., Banke, K., Slama, D. (2005): *Enterprise SOA: Service-Oriented Architecture Best Practices*, Upper Saddle River 2005
- [Maier 2007] Maier, R. (2007): *Knowledge Management Systems. Information and Communication Technologies for Knowledge Management*, Berlin 2007
- [Maier and Schmidt 2007] Maier, R.; Schmidt, A. (2007) *Characterizing Knowledge Maturing: A Conceptual Process Model for Integrating E-Learning and Knowledge Management*, 4th Conference Professional Knowledge Management, Potsdam
- [Pammer , Ley and Lindstaedt 2008] Pammer, V., Ley, T., Lindstaedt, S. N. (2008). Tagr: Unterstützung in kollaborativen Tagging-Umgebungen durch semantische und assoziative Netzwerke. GMW Expert Workshop "Social Tagging in der Wissensorganisation – Perspektiven und Potenziale", Tübingen, 21/22 February 2008.
- [Riss 2005] Riss, Uwe V. (2005) *Knowledge, Action, and Context: Impact on Knowledge Management*. In: K.-D. Althoff, A. Dengel, R. Bergmann, M. Nick, T. Roth-Berghofer (Eds.): *Professional Knowledge Management, Lecture Notes in Artificial Intelligence*, Vol. 3782.
- [Scheir, Ghidini and Lindstaedt 2007] Scheir, P.; Ghidini, C.; Lindstaedt, S. N. (2007). *Improving Search on the Semantic Desktop using Associative Retrieval Techniques*, Proceedings of I-MEDIA 2007 and I-SEMANTICS 2007, Graz, Austria, pp. 221-228
- [Schmidt 2005] Schmidt, A. (2005): *Knowledge Maturing and the Continuity of Context as a Unifying Concept for Knowledge Management and E-Learning*. Proc. of I-KNOW 2005, Graz.
- [W3C 2004] Haas, H. and Brown, A., eds. (2004) *Web Services Glossary*, W3C Working Group Note, <http://www.w3.org/TR/ws-gloss/> (visited 2 May 2008)

# **Information Retrieval Services for Heterogeneous Information Spaces**

**Julian Bahrs, Benedikt Meuthrath, Kirstin Peters**

(Business Information Systems and Electronic Government, University of Potsdam, Germany  
{jbahrs, bmeuthrath, kpeters}@wi.uni-potsdam.de)

**Abstract:** Many enterprises lose work time because they lack of global search solutions or their solutions are not able to satisfy the needs in a reasonable time. This results in costs for lost work time as well as increased response time. We present a novel approach to federated search engines that use case based reasoning to rerank results according to the searchers needs and therefore leads to a higher quality of search results and faster information retrieval.

**Keywords:** enterprise search, information retrieval, case based reasoning, web services, heterogeneous information space

**Categories:** H.3.1, H.3.3, M.0, M.5, M.7

## **1 Introduction**

In this contribution we present an approach for a self learning search (SLS) system based on case-based reasoning (CBR) to improve result merging and ranking in federated search environments in heterogeneous information spaces. This approach is implemented into a service-based architecture for federated search engines.

First, current limitations and problems in enterprise search are outlined [Chapter 2]. Then we present the architecture of a federated search engine based on search services [Chapter 3]. This system is enhanced with profile and context based search [Chapter 4] as well as feedback mechanisms for learning quality. Finally, we outline a CBR system, to improve future queries [Chapter 5].

## **2 Enterprise Search**

Today, many enterprises cannot access their digital information through a unified search infrastructure [Bahrs, 07]. This leads to lost work time resulting in additional costs and increased response time [Feldmann, 04]. However the powerful and widely accepted search tools used in the internet cannot directly be transferred to enterprises. Enterprise search should cover more than the intranet web pages which are available to all employees. In this contribution enterprise search is understood as search over all text content available in electronic form, including an organization's internal websites, its external websites as well as database records, email or documents [Hawking, 04].

The information space of enterprises differs significantly from the web or classic document collections. It lacks a similar or widely acknowledged structure, such as documents or web pages. In enterprises a collection of elements has to deal with

different formats, such as documents, web pages, database records stored in various systems, folders, hard disks and databases, each with unique interfaces. This results in a heterogeneous structure and decentrally stored information space. Second, major parts of a company's information are protected by access rights. The deep web, which stands for content available after forms or even logins, can be understood as an equivalent. Even leading web search engines mostly ignore this content. In contrast it is a necessity in an enterprise to access protected information, as it affects major parts of the overall information. This conflicts the idea of a central index for two reasons: While concepts for central identity management are known, most enterprises are stuck with locally managed access rights, resulting in multiple systems to prove the identity of a searcher. Further, the index would have to replicate the complete access rights in order to hide results not intended for search. This is feasible for a document collection where access rights are granted for complete elements. But it clearly is a difficult task with applications and databases, where access rights are more granular. For example a record set of a customer may be viewed by everyone, while orders are only available to selected users.

In general, the quality of search results increases, if smaller domains are addressed, because content acquisition and indexing as well as query processing can adapt to content specifics. However, this is difficult to achieve with an approach to enterprise search based on the described concept of a search engine. Therefore, enterprise search often leads to a situation of federated search of multiple search engines, where a search engine forwards a search term to a number of underlying search engines and collects result sets. This reflects a conceptual analogy to the information space of enterprise and overcomes the described shortcomings. The new approach is described in [Chapter 3]. The drawback of these systems is the limited ability to merge to an overall relevance ranking [Hawking, 04]. This problem is addressed by the self learning approach presented in the following chapters 4 and 5.

### 3 Architecture of the Self Learning Search Engine

The SLS prototype is a federated search engine with a modular architecture build upon web services. These web services are provided by different information sources. An information source is itself a search engine for a small domain, that needs to provide at least a uniform resource identifier (URI) [Berners-Lee, 05], a ranking value and an optional description per result.

The architecture of the SLS prototype as shown in [Figure 1] is modeled using the Fundamental Modeling Concepts (FMC). FMC is a modeling technique to support the communication about information processing systems. In [Figure 1] a block diagram is shown to describe the compositional structure of the system in terms of active and passive components. Squares are used to model agents that are active and process information, while rounded figures are used to model storages and small circular figures to model communication channels. Both rounded and small circular figures are passive components to keep or transport information. This structure describes which agent can access which data and communicates with other agents via channels or shared storages.

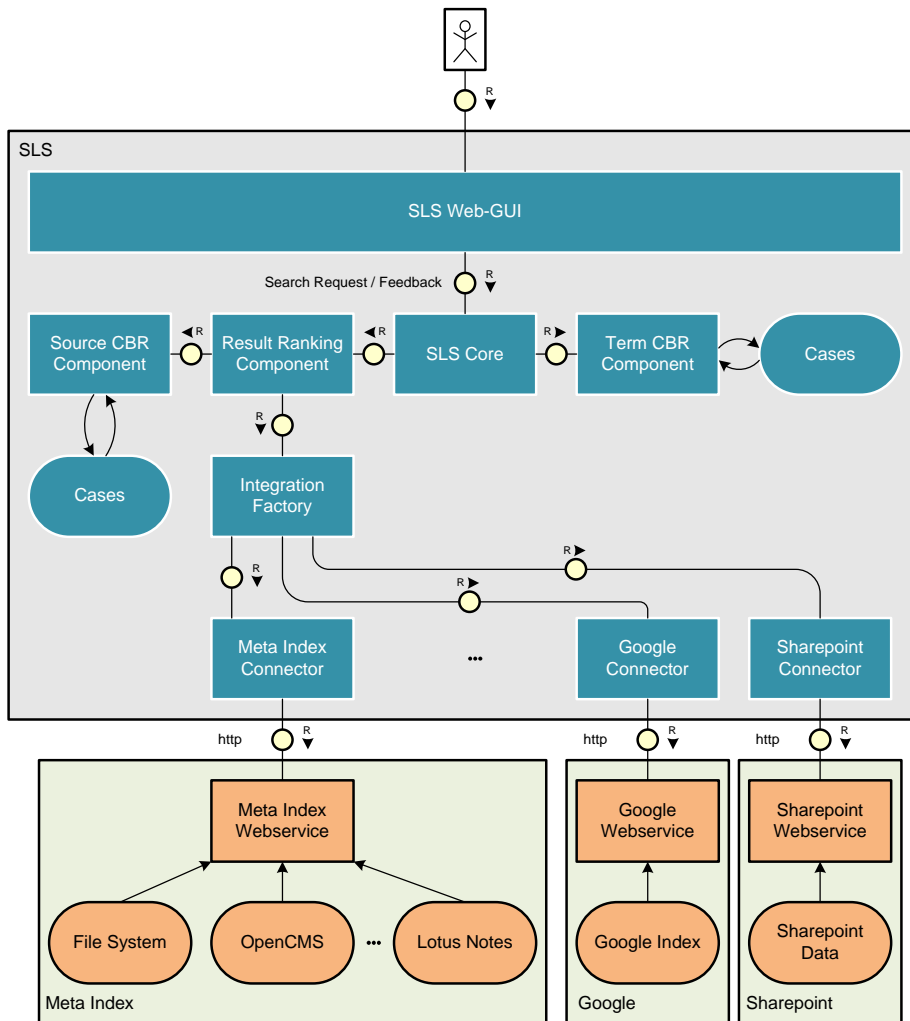

Figure 1: SLS prototype architecture

The SLS prototype consists of a core application, using a web based graphical user interface to communicate with the user. The user is enabled to enter login data that is forwarded to the underlying search engines. Furthermore, for each search request the context has to be chosen [see Chapter 5] and submitted together with a search term. The core application forwards this information to a ranking component, which in turn uses the Integration Factory to instantiate connectors for the supported search engine web services. The ranking component collects the search results, merges them into a single result list and reranks the results according to ranking values calculated by the source CBR component. This CBR component uses the z-scores of original ranking value delivered by the web services and retrieved cases to

calculate a new ranking [see Chapter 5]. The results are presented as a list to the user. Users are encouraged to give feedback in form of an evaluation of several results. This feedback is forwarded to the source CBR component. On the other side there is a term CBR component, which stores the search terms that lead to positive evaluated results. This is used to suggest similar search terms based on previously learned successful search requests [Gronau, 03].

The connectors can be variable in implementation. The Meta index connector for example connects to a web service that returns results for more than one source, which allows for further slicing and narrowing the search domain in large collections, e.g. SharePoint. As long as the connector returns a single result list with information about the source added to every result, the SLS prototype can handle this.

#### **4 Personalization of search results**

The architecture presented above increases the reach of a query and with that also the number of results, because searches are now forwarded to multiple information sources simultaneously. This takes the burden from the user to know and chose the appropriate search engine. However, relevant results may be buried among others. As most users only inspect a very limited number of results, ranking is critical [Joachims, 07]. In our approach ranking is addressed in two places. First, each search service applies its own ranking, which may make use of mechanisms specific to the content of the source. Second, a general reranking is applied based on properties of the user (profile) as well as the situation or goal anticipated with the search query (context).

As with similar approach to personalization, the profile information can be used to rerank or filter a set of results or to enhance the query based on attributes of the user issuing the search query [Riemer, 07]. Most approaches rely on a classification of content and defined profiles of interest. These are either defined prior to search request or are captured by collecting user activity with the search engine [Keenoy, 05]. However, such a profile of interest relies on deeper knowledge of the content and an overall taxonomy, and therefore has to be performed on the level of the search services. To address this personalization (and for handling access rights) we forward information on the users identity to the search services.

On the integrating layer, the selection (preference) of search services can be associated based on profiles. In analogue to the above, these preferences can be either predefined or derived from previous user activity. In our approach we anticipate the later, as it does not require initial set up. We incorporate profiles on the level of a group, instead of individual profiles. This has the advantage that learned improvements can be used for all users with the same profile. We make use of an attribute that is well known within an enterprise: departmental structure. However, searchers may follow different goals with multiple search requests.

We therefore use a second variable that is created or chosen from a list of previously created contexts by the user with each search request. Contexts represent a brief description of the search goals. The list of contexts is maintained per profile and is shared by a group of users.

During set up, an initial set of contexts can be derived through analyzing and labeling all information consuming activities of the members of a profile. One



approach to identify and visualize such knowledge activities is the Knowledge Modeling and Description Language (KMDL) [Gronau, 05].

## 5 CBR System and Learning by feedback

Because of the dynamics in organizations the relevant sources and tasks change overtime, e.g. if a new database is established. The allocation of information sources to tasks needs to be updated permanently. This can be achieved with case-based reasoning.

Case-based reasoning is a machine learning concept and means solving problems by using experiences from similar situations. Roger Schank presented the central role of reminding earlier situations for human reasoning and learning [Schank, 82]. Experiences are saved in form of cases consisting of a problem description, a solution, an evaluation of the solution and any additional information the CBR system may use. The key idea is, that similar problems require similar solutions [Kolodner, 92, Leake, 96, Rissland, 87].

Problem solving with CBR can be divided into four steps illustrated in the CBR cycle [Aamodt, 94] in [Figure 2]: *Retrieve* similar cases from the case base. *Reuse* the information in these cases to solve the new problem. *Revise* the proposed solution and *retain* the new case including problem description, solution and evaluation in the case base for future use [Aamodt, 94].

The CBR system can learn from its experiences, which information sources are relevant for which tasks, by remembering a request for a similar task and the preferred sources in this situation. The task, i.e. the intention of the request, need to be stated by the employee. The profile outlines the general tasks of an employee and with it the general intention of his requests. The context, however, specifies the intention of a request and improves the profile.

To learn which sources are preferred, the CBR system needs some kind of feedback about the quality of presented search results. There are different kinds of feedback discussed in the literature [Kubat, 07, Joachims, 07, Sharma, 05, Kelly, 03]. If the feedback is positive the CBR system will prefer the corresponding source next time.

Our enterprise search engine expects a normalized ranking value for each search result. The CBR system allocates a pushing coefficient to each information source. If the feedback is positive the pushing coefficient of the corresponding source is increased and the results of this source are pushed up in ranking next time, i.e. the normalized ranking values of all results of this source are pushed with this coefficient. If the feedback is negative the pushing coefficient is decreased and the results are pushed down in ranking. [Figure 2] shows the learning cycle of the CBR system.

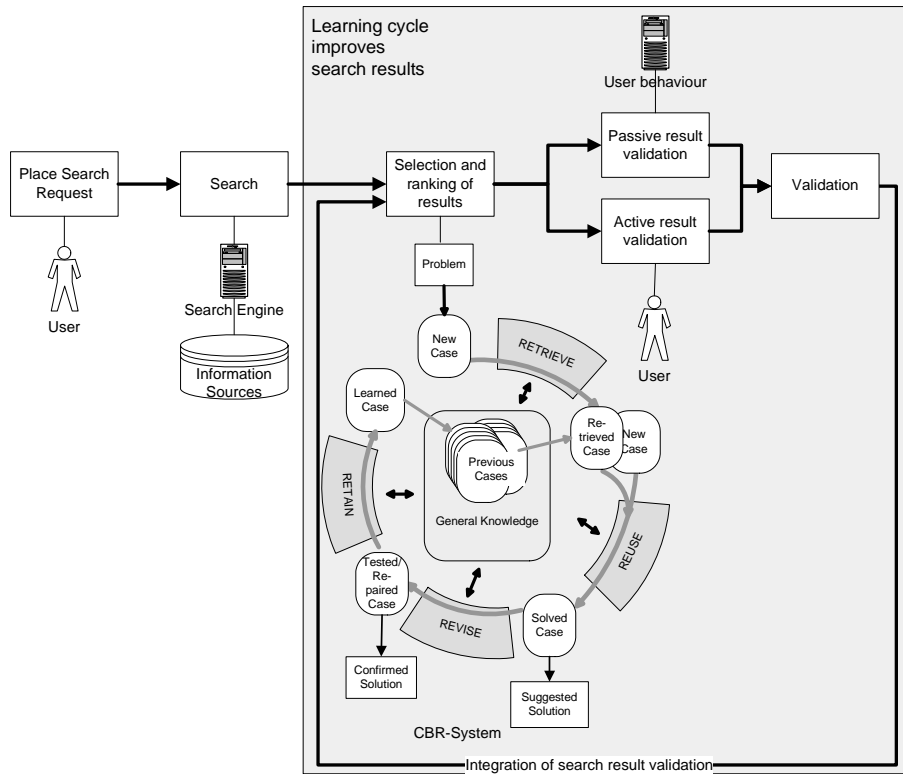

Figure 2: Process of self-learning search engine.

As described above, the intent of a request is used to choose relevant sources. The profile of the searcher and a chosen context is used to characterize this intent, i.e. the problem description of a case consists of a profile and a context. Two cases are equal, if their profile and context are equal. Later we will improve this by additional similarity pointers. To search for a case similar to a new case, profile and context are checked for equality. If no case is found, the new case is added to the case base according to its profile and context.

The solution of a case is a list with a pushing coefficient per information source. The purpose of the coefficients is to push up the information sources in ranking that fits best to the intention of the searcher. Because searchers usually only examine the results with the highest ranking coefficients, pushing the results directly influences the quality of search. Pushing all results of an information source is due to the assumption, that different information sources contain different kinds of information and the ranking within an information source is already done well by the according search service. Obviously the approach needs a high number of information sources to work well. Few sources would lead to few differences between cases.

At the beginning new cases are saved without pushing coefficients. Instead of this an initial coefficient is used, that does not influence the normalized ranking values. The entries of the pushing coefficients are established, as soon as the corresponding

information source is evaluated for the first time. This enables an easy enhancement to additional information sources.

Remembering previous cases is also fundamental to learning in CBR. The new case, consisting of a problem description, a proposed solution and an evaluation is saved in the case base.

In addition, another kind of learning is used to enhance the reasoning process. Because the profiles are not completely disjoint, it is possible that two combinations of profile and context describe the same task. It is also possible, that two contexts in one profile describe the same task, because each employee can generate new contexts. To ensure that the list of contexts will not become too long and overlapping, the number of contexts for each profile should be restricted.

The system needs to be trained first in order to build a useful case base. This training phase is completed, if the CBR system reaches a kind a stable state, i.e. the number of cases is almost stable and the coefficients change little and slowly. How long this training phase lasts depends strongly on the current situation. After that the system checks in each retain phase, whether the revised solution of the current case is very similar to another solution in the case base. Two solutions are very similar, if the values of the pushing coefficients are equal for all information sources or differ in only a few values with only little distance. Appropriate thresholds should be generated with respect to the overall number of information sources. Cases with very similar solutions are linked by a similarity pointer and are further treated as equal, i.e. feedback given for one case is also used for every case linked to it. Those cases are used as if they would describe the same situation, i.e. the cases are generalized. Two contexts in one profile, linked by a similarity pointer for a long time, are merged.

The ranking of the results deeply influences, which results are examined [Joachims, 07]. So there is the danger, that only the results of information sources with high pushing coefficients are further examined and evaluated. If we use feedback only to calculate the pushing coefficients, results of sources with bad coefficients are no longer noticed and no feedback is produced for them. Because of the dynamics in organizations, the intention of a task or the content of an information source could change, so it is necessary to reconsider the coefficients, i.e. to relativize not approved pushing coefficients. Pushing coefficients that have not been approved for a long time are reset stepwise to the initial pushing coefficient.

Because of the dynamics in enterprises similarity pointers can become faulty. So they are eliminated, if new feedback contradicts the last feedback of a linked case. Consider e.g. a combination of profile and context treated similar until a new information source is added. If contradicting feedback is stated for this new source, e.g. because the source includes information only relevant for one of the profiles, the similarity pointer linking these two combinations should be removed.

## 6 Conclusions

Finding relevant information is an actual challenge in enterprises. A federated search engine is an obvious approach to handle the amount of potential information sources. Naturally relevancy depends on the intention of the search engine user. Our approach allows the system to learn the correlation between the search context and the

relevance of the information sources. This information leads to a modified ranking of search results, resulting in higher quality result list.

Further research of a mature case base may provide a complete list of all classes of information requirements. This enables the identification of unsatisfied information requirements, e.g. contexts whose information sources were marked irrelevant. This knowledge can be used to improve information landscape. Further key information sources are identified through analyzing the case base.

Our approach is self adapting to heterogeneous information landscapes. It completely relies on self learning algorithms and requires no initial case set up. We circumvent modeling of the context or information need. Instead we assign labels to it and the system learns the preferences. Modeling the information need or assigning information sources would pose a substantial knowledge engineering task, especially if users operate with multiple applications [Fenstermacher, 02].

## 7 Outlook

A prototypical implementation of SLS on basis of existing open source meta search engines is currently in realization. In a pilot installation the prototype is tested in different stages of development and collects in an extensive log file every single action of all users. The stages of development are as follows: 1. A regular use as meta search engine, 2. with forced validation of the opened links, 3. with personalization and 4. with selected context and reranking by the source CBR component. With this data we want to prove an increase in efficiency in terms of less clicks to a successful hit and a superior validation of hits by the users.

## References

- [Aamodt, 94] Aamodt, A., Plaza, E.: "Case-Based Reasoning: Foundational Issues", Methodological Variations, and System Approaches. 1994.
- [Bahrs, 07] Bahrs, J., Schmid, S., Müller, C., Fröming, J.: "Knowledge Management in practice – empirical study" (in german). Gito (Berlin), 2007.
- [Berners-Lee, 05] Berners-Lee, T., Fielding, R., Masinter, L.: "RFC 3986 - Uniform Resource Identifier (URI): Generic Syntax". The Internet Society, IETF, January 2005
- [Feldmann, 04] Feldmann, S.: "The high cost of not finding information". <http://www.kmworld.com/Articles/ReadArticle.aspx?ArticleID=9534> (Abruf am: 21.11.2007).
- [Fenstermacher, 02] Fenstermacher, K. D.: "Process-Aware Knowledge Retrieval". 35th Annual Hawaii International Conference on System Sciences (HICSS'02), IEEE Computer Society (Island of Hawaii, USA), 2002.
- [Gronau, 03] Gronau, N., Laskowski, F.: „Using Case-Based Reasoning to Improve Information Retrieval in Knowledge Management Systems“. In: E. Menasalvas, J. Segovia, P. Szczepaniak (Hrsg.): Advances in Web Intelligence. Proc. AWIC 2003, Madrid, May 2003, 94-102
- [Gronau, 05] Gronau, N.; Korf, R.; Müller, C.: "KMDL - Capturing, Analysing and Improving Knowledge-Intensive Business Processes". Journal of Computer Science, 4, 2005; S. 452-472.

- [Hawking, 04] Hawking, D.: "Challenges in enterprise search". Klaus-Dieter Schewe, Hugh Williams (eds.): Proceedings Fifteenth Australasian Database Conference, Volume 27. Australian Computer Society, Inc. (Dunedin, New Zealand), 2004, 25-24.
- [Joachims, 07] Joachims, T., Radlinski, F.: "Search Engines that Learn from Implicit Feedback". In *Computer*, 40(8):34–40, 2007.
- [Keenoy, 05] Keenoy, K., Levene, M.: "Personalisation of Web Search"; In: *Intelligent Techniques for Web Personalization - IJCAI 2003 Workshop, ITWP 2003, Acapulco, Mexico, August 11, 2003, Revised Selected Papers*. Springer (Berlin), 2005, 201-228.
- [Kelly, 03] Kelly, D. and Teevan, J.: Implicit feedback for inferring user preference: a bibliography. In *ACM SIGIR Forum*, 37(2):18–28, 2003.
- [Knoepfel, 05] Knöpfel, A., Gröne, B., Tabeling, P.: "Fundamental Modeling Concepts. Effective Communication of IT Systems"; John Wiley & Sons Ltd., Chichester (2005).
- [Kolodner, 92] Kolodner, J.: "An introduction to case-based reasoning"; In *Artificial Intelligence Review*, 6(1):3–34, 1992.
- [Kubat, 07] Kubat, M., Tapia, M.: "Time spent on a web page is sufficient to infer a user's interest"; In *Proceedings of the IASTED European Conference: internet and multimedia systems and applications table of contents*, pages 41–46, 2007.
- [Leake, 96] Leake, D.: "CBR in Context: The Present and Future. Case-Based Reasoning: Experiences, Lessons, and Future Directions"; pages 3–30, 1996.
- [Page, 98] Page, L., Brin, S., Motwani, R., Winograd, T.: "The PageRank Citation Ranking: Bringing Order to the Web". <http://dbpubs.stanford.edu:8090/pub/1999-66> (Fetched: 10.12.2007).
- [Riemer, 07] Riemer, K., Brüggemann, F.: "Personalization of internet search – techniques and market overview". In: *Wirtschaftsinformatik*: 49, 2, 2007, S. 116-126.
- [Rissland, 87] Rissland, E. and Ashley, K.: "A case-based system for trade secrets law". In *Proceedings of the first international conference on Artificial intelligence and law*, pages 60–66, 1987.
- [Schank, 82] Schank, R.: *Dynamic Memory: "A Theory of Reminding and Learning in Computers and People"*. Cambridge University Press New York, NY, USA, 1982.
- [Sharma, 05] Sharma, H., Jansen, B.: "Automated evaluation of search engine performance via implicit user feedback". In *Proceedings of the 28th annual international ACM SIGIR conference on Research and development in information retrieval*, pages 649–650, 2005.
- [Shtykh, 07] Shtykh, R., Jin., Q.: "Enhancing IR with User-Centric Integrated Approach of Interest Change Driven Layered Profiling and User Contributions". In *Advanced Information Networking and Applications Workshops*, 1, 2007.

# Semantic Task Management Framework

Ernie Ong<sup>1</sup>, Uwe V. Riss<sup>2</sup>, Olaf Grebner<sup>2</sup>, Ying Du<sup>1</sup>

<sup>1</sup>SAP Research, Belfast, U.K.

<sup>2</sup>SAP Research, Karlsruhe, Germany

ernie.ong@sap.com, uwe.riss@sap.com, olaf.grebner@sap.com, ying.du@sap.com)

**Abstract:** Despite the growing importance of knowledge work in today's organizations, its support by means of ICT tools is still rather limited. Recent trends in semantic technologies provide novel approaches for an effective solution to these challenges in terms of semantic-based task management. However, task management involves the complex interplay of information and work activities. Thus a semantic task management framework is needed which supports an adaptable semantic foundation, to meet the challenges of knowledge work, via a set of task services on the desktop. To this end, we propose the Nepomuk Semantic Task Management Framework (STMF) as platform for a task-oriented ecosystem for desktop applications.

**Keywords:** knowledge work, task management, social semantic desktop

**Categories:** : H.5.3, K.8.0, M.5

## 1 Introduction

Knowledge work (KW) plays a decisive role in the success of knowledge intensive enterprises and beyond. Consequently, the need for effective support in KW grows increasingly urgent. However, KW is quite a recalcitrant domain with respect to ICT support since it is characterised by highly variable activities of highly skilled knowledge workers (KWers) operating both autonomously and collaboratively [DeFillippi, 06]. There are two core aspects in KW: (1) supporting the management of **information artifacts**, and (2) supporting the coordination of **work activities** – or *task management* (TM) in short. Both are closely entwined and require a joint handling to provide thorough benefit to KWers [Riss, 05b].

Recent emerging trends in semantic technologies provide better support for KWers' Personal Information Management on the desktop [Sauer mann, 05]. This also affects task management with respect to the complex interplay of information and work activities. To fully integrate and support TM the semantic framework has to provide a set of task services which can be leveraged from within existing desktop applications to meet the KWers' demands. Therefore the Nepomuk Semantic Task Management Framework (STMF) is built on the Social Semantic Desktop (SSD) that provides such a foundation and meets the challenges of KW, which are described in the following issues:

**Modelling:** provision of uniform and flexible semantic models of information artifacts and work activities in different social layers (personal vs. organizational) and in different modelling layers (application vs. domain). Here, the STMF exploits the extensible model provided by the Task Model Ontology (TMO) [Nepomuk, 06].

**Knowledge:** capture and reuse of explicit and implicit knowledge to support knowledge work. To this end, STMF provides the infrastructure to handle information and process-oriented knowledge within common productivity applications. Seamless annotation of semantic metadata in existing work processes and tools is crucial.

**Infrastructure:** support a task-oriented ecosystem for all desktop applications in a networked environment. This originates from our perspective of tasks as a generic concept that is pervasive across applications and user activities on the desktop, and represents a conceptual hub for organizing information and work activities. STMF additionally narrows the gap between semantic technologies and conventional development technologies to foster widespread adoption.

Architecturally, the STMF is designed as a task management component on top of the fundamental semantic layer, the Nepomuk middleware [Groza, 07]. The STMF provides an interface to desktop applications which require a uniform task model and specific task services. In this respect, the STMF does not see task management as an application on the desktop among others but as a fundamental layer for applications, which deal with tasks and thus require task services, to coordinate all task related activities across all desktop applications.

In Section 2 we first describe the Nepomuk approach of the Social Semantic Desktop as the basis for our approach before we come to the description of the STMF in Section 3. Section 4 provides a short glance at related work. In Section 5 we conclude the paper with a discussion of the results.

## 2 General Approach

In this section we give some motivation for introducing the STMF. We see task management as a bundle of desktop-wide services that are available for *all* desktop applications to support *all* user activities on the desktop. As such they are bundled in an application embracing framework that application developers can apply to integrate task management in a manner that is consistent with the character of their applications.

For the application developer the STMF brings the advantage that they can deal with a stable interface independent of changes to the ontologies in underlying semantic foundation layer and accessible in a uniform way. The set of services that are offered by the STMF is specific for the task management functionality, i.e., application developers are not required to work with the semantic infrastructure consisting of several ontologies but they can access tasks directly as SOAP web services.

For the KWer the integrating framework allows a uniform access to TM functionality all over the desktop, even if this is not a mandatory consequence. Since the STMF only provides an API and acts as a façade to underlying semantic and context services, task user interfaces may be adapted in a contextual way so that the particular needs of KWers in their specific work situation are optimally addressed.

Semantic integration yields clear advantages for TM since tasks are no longer isolated entities that might possess some task-specific metadata and attachments but provide a comprehensive picture of the KWers' work sphere, i.e., they are part of their personal semantic network on the desktop. Often tasks are the natural access

point for KWers to find required information, e.g., we can often remember in which context we have last dealt with a specific document but not where it is stored.

Finally, the STMF supports the social aspects of metadata and task management such as the combined transfer of both via email to delegate work including the respective context of task related information objects and metadata. This offers opportunities to implicitly enlarge the delegate's personal semantic network.

The basis for the STMF is the Social Semantic Desktop (SSD) [Groza, 07]. It essentially incorporates the Semantic Web paradigm to conceptualize the KWers' desktop data and their personal mental models. It makes use of a set of ontologies and a set of Web Services that ensure standardized interfaces and capabilities. The NEPOMUK project provides a standardized SSD architecture that is independent of specific operating systems or programming languages.

## 2 Semantic Task Management Framework

The design and implementation of Nepomuk STMF and its underlying task model called Task Model Ontology (TMO) rely on the Nepomuk semantic foundation layer, i.e., the set of services and ontologies provided by it. The TMO addresses the need for a semantic model for TM comprising a description of information artifacts and work activities. The STMF, on the other hand, provides uniform and pervasive access to task data and services across applications and user activities on the desktop. Beneath the central role of the STMF for the Nepomuk task management, applications on the SSD can access TM data using direct access to the semantic task description in the RDF format allowing the developer to leverage the full expressiveness of the format.

### 2.1 Task Model Ontology (TMO)

The central challenge of task management is providing effective task-related information support to knowledge workers. To this end, the underlying task representation, the TMO, must be highly expressive and yet extensible to cater for ill-defined and continuously changing knowledge-intensive work situations.

Consequently, the TMO is structured in two layers: (1) A set of classes and resources which describe task-oriented information and work activities, and (2) an underlying set of Nepomuk classes which support the elaboration or concretization of the more generic concepts e.g. the Personal Information Management Ontology (PIMO) [Sauermann, 06]. To increase the flexibility and extensibility of the TMO, we have introduced a distinction between intrinsic and extrinsic TMO properties. Intrinsic properties are those which are fundamental to task modelling whereas extrinsic or incidental properties enrich the core task descriptors. In this way users are not only free to construct and evolve a highly personalised information model but they can further augment the TMO with new concepts.

### 2.2 STMF Services

One of the main impediments to the widespread adoption of task management is the lack of support for tasks and their respective artifacts as first-class citizens on the desktop. This leads to a dichotomy that separates the management of tasks from the



work contexts from which they arise. This artificial separation does not only increase the cognitive load of end-users who need to regularly switch between applications, it also precludes any possibility of defining semantic relations between information artifacts as described above.

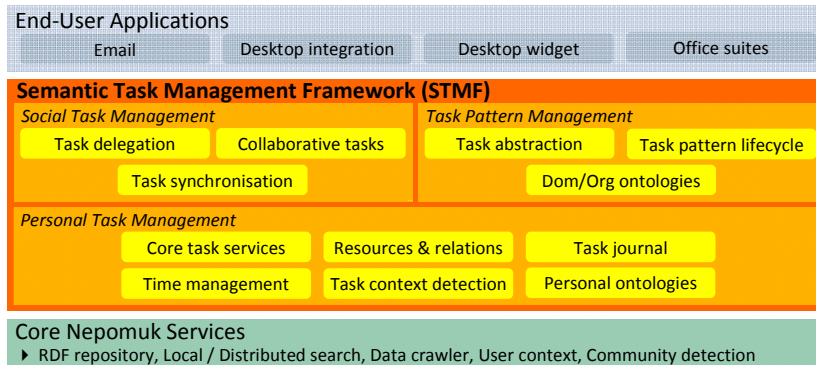

Figure 1: Overview of STMF Components

Effective support for task management on the desktop is predicated on pervasive access to tasks and task services across the desktop, e.g., from different applications, with a consistent data model. While the data model has been described in the last section we now turn to the description of the task services provided by the STMF.

The STMF consists of three categories of task-related services: Personal Task Management, Social Task Management, and Task Pattern Management. **Personal Task Management (PTM)** is the basic layer in the STMF (cf. Fig. 1). It includes *core task services* to create, maintain and delete tasks. Besides, there are other services to enrich tasks. This enrichment includes *resource and relation* handling, e.g., to relate documents or persons to tasks, and *task context detection*, e.g., to relate currently open documents to tasks. Semantic management of task resources is explicitly supported within the TMO but can be further extended via *personal ontologies* and tagging. Moreover, it offers a *task history* to reflect task chronology and *time management* to support users in efficiently organizing task regarding time constraints.

In knowledge work, it often arises that a single person is unable to adequately complete a task due to complexity which requires a multitude of expertise. Such collaboration is supported by **Social Task Management**. In this respect the STMF enables different kinds of cooperation between KWers, e.g., *task delegation*. The respective services enable the exchange of task data including associated information objects. This also encompasses the exchange of metadata that belongs to these information objects including attributes and semantic relations. Exchange of task data therefore goes beyond the conventional use of email and unstructured text as the basis for task descriptions towards a more structured approach via the use of semantics. These services are encapsulated within the STMF and do not impact the user. Beside task delegation there are services to support *collaborative tasks* in which KWers more closely work together, e.g., sharing a common task information space. It supports delegation protocols to control the processes of task delegation and metadata transfer

in order to realize *task synchronization*, e.g., for mutual updates of task status information between delegating and delegated tasks.

Finally, we plan to provide services for **Task Pattern Management** that are designed to support experience reuse via task patterns [Riss, 05a]. These task patterns will help KWers to perform new tasks on the basis of recommendations extracted from similar tasks but adapted to new application contexts. The required similarity measures will be based on *task ontologies* that refer to the KWers' business domain. Services will support the categorization of individual tasks via the similarity measures and the extraction of task patterns as *abstractions* of groups of similar tasks, e.g., on the basis of the activities performed within similar tasks as recorded by the *task journal*. Finally, we will provide services that enable the knowledge transfer from personal to collective where the knowledge reuse and organizational learning is possible [Ong, 07]. This will establish a *task pattern lifecycle*.

### 2.3 STMF Architecture

The overall architecture of the STMF and its environment is depicted in Figure 2.

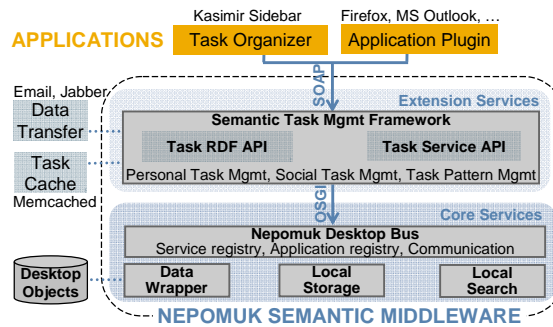

Figure 2: STMF Architecture within the Nepomuk Semantic Middleware

It shows the Nepomuk Middleware that is organized into *Core* and *Extension Services*. Core Services provide the foundational functionality on which the Extension Services are built. All internal communication within the Middleware is based on Java-OSGI whereas applications outside the Middleware rely on platform and language agnostic technologies based on HTTP such as SOAP web services when interacting with a Nepomuk service. The STMF provides Extension Services that use the following Nepomuk Core Services:

- *Nepomuk Desktop Bus* – This acts as a registry and communication layer for semantic Nepomuk services.
- *Data Wrapper* – The *Aperture Data Wrapper* crawls the desktop for *Desktop Objects*, e.g., emails and documents, and adds annotations to the *RDF Store*.
- *Local Storage* – The *RDF Store* based on Sesame2 provides the semantic database for all semantic data.
- *Local Search* – This provides access to semantic data in the *RDF Store* via SERQL and SPARQL queries.

Architecturally, the STMF services are platform and language independent. This is realized by the provision of SOAP web services. From an interface perspective, the STMF services are exposed via two API sets. The first and lower-level API (*task RDF API*) focuses on data access and comprises an RDF interface, the aim of which is to expose task data to semantics-aware applications capable of exploiting the semantic data. This interface provides client applications with direct access to the task data in the RDF Store with both SERQL and SPARQL query support.

Since most conventional applications are not capable of processing semantic data but are object-oriented, the STMF provides a transformation layer which converts RDF data to the object paradigm and thus enables the easy integration of task management within such applications. To this end the STMF also provides a second and higher-level API (*task service API*) that enables both data access and the task management services described above. Internally, the task service API uses the task RDF API to manage the underlying data.

The STMF defines an internal *Data Transfer* layer to manage the transmission of task messages between Nepomuk desktops, e.g., for task delegation and synchronization. The actual implementation can be realized in various ways, e.g., via email or other transport mechanisms such as the XMPP protocol. In the current implementation, the STMF realises the Data Transfer layer by providing interfaces to STMP/POP (email protocol) and to Microsoft Outlook via COM technology. The latter provides full access to the Outlook application model which can be further exploited to access and manipulate Outlook objects including email, address book entries and calendar entries. This enables additional opportunities for bringing email and desktop personal information management tools closer to task management.

Early tests of the STMF in *Task Organizers* such as the Kasimir Task Sidebar [Grebner, 08] have revealed a need for higher performance read operations. Such situations arise regularly when a user routinely navigates between tasks in the Task Sidebar. To this end, the STMF uses a dedicated *Task Cache* to cache frequently read task data. The current STMF uses a desktop-based **memcached** server,<sup>1</sup> a high performance distributed object cache. In preliminary tests, users have noted visible improvements to responsiveness which has had a significant impact on the usability of the Task Sidebar. From a design perspective, caching is realized in a way that is transparent to the core STMF components thereby clearly separating the concerns of provisioning of task management functionality, data caching and data access.

The use of an external cache server, as opposed to one that is tightly integrated within the STMF, has two indirect benefits. Firstly, this architecture enables the STMF to be deployed separately as a Java framework within Java applications. This results in further performance gains due to the binary-level integration with the STMF. In such a deployment, the STMF instance accesses the Nepomuk Core Services via HTTP for data management only. Secondly, the use of an external cache and a write-through caching policy ensures task data consistency across all STMF instances on the desktop in addition to increasing the cache hit rate, and therefore performance, across STMF instances.

The current STMF is designed as a façade that uses service composition to mediate access to the underlying Nepomuk services in addition to orthogonal

---

<sup>1</sup> [www.danga.com/memcached](http://www.danga.com/memcached)

services, e.g., caching and data transfer. Extensions to the STMF can be realized by delegating stable functionality to the existing STMF (closed for modification). New functionality, on the other hand, can be intercepted and handled separately (open for extension). This adheres to the Open-Closed Principle.<sup>2</sup> From an architectural perspective, an STMF extension can be realized as an additional Extension Service within the Nepomuk Semantic Middleware or as a separate web service. In this way, multiple monotonic variants of the STMF can co-exist on the same desktop.

### 3 Related Work

An approach rather close to the STMF is the Unified Activity Management (UAM) project at IBM Research [Moran, 05; Cozzi, 06]. The WAX system that results from this approach provides a Web service framework that applies a semantic representation of activities (or tasks) similar to the present approach. In the same way as the STMF it focuses on collaborative task handling, support of unstructured information and a plug-in approach.

The key difference between the STMF and other approaches such as UAM mainly consists in its embedding in the SSD. Thereby we obtain a seamless integration of tasks and other desktop objects that gives KWers universal access to information inside and outside tasks. A further benefit is that extensions to the standard SSD semantic model with personal, domain or organisational ontologies are also well integrated into the STMF. The SSD therefore provides not only services on which to realize the STMF but also a solid modelling foundation on which to enrich task descriptions. One final deviation between the two approaches is the strong foundation for modelling activities within tasks via task journals in the STMF. This forms the basis for enabling task experience reuse.

### 4 Conclusions and Future Work

The STMF philosophy regards tasks as a natural hub for integrating information, semantics and work process descriptions. As a natural consequence, the goal of the STMF is to realize a task-oriented operating environment for the desktop that provides KWers with more effective work process and information support. This requires semantic integration of KM and TM within productivity tools KWers use to perform their daily work. To this end, the STMF provides a uniform *task model* across all applications and user activities, and realizes a pervasive set of *task services* thereby elevating tasks and task services to first class citizens across the desktop

In the longer-term, we plan to provide more effective support for experience transfer and reuse via *task patterns*. This includes the effective integration of external ontologies and the introduction of multi-faceted context management within the STMF. The former leverages the potential of Nepomuk to integrate the TMO with personal, domain and organisational ontologies to provide a richer means by which multi-faceted task context can be modelled and captured. This in turn provides a

---

<sup>2</sup> <http://www.objectmentor.com/resources/articles/ocp.pdf>

means to leverage maturing activities and services for information, semantics and work processes.

### Acknowledgements

This work was supported by the European Union IST fund (Grant FP6-027705, project NEPOMUK).

### References

- [Cozzi, 06] Cozzi, A., Farrell, S., Lau, T., Smith, B., Drews, C., Lin, J., Stachel, B., & Moran, T. P. 2006, *Activity management as a web service*. IBM Systems J., 45(4), 2006, pp. 695-721.
- [DeFillippi, 06] DeFillippi, R.J., Arthur, M. B., Lindsay, V. J. 2006, *Knowledge at Work*, Oxford, Blackwell, 2006.
- [Grebner, 08] Grebner, O., Ong, E., Riss, U. V. 2008, *KASIMIR – Work process embedded task management leveraging the Semantic Desktop*. In: Martin Bichler et al., ed., Proceedings of 'Multikonferenz Wirtschaftsinformatik' MKWI 2008, Berlin, pp. 715-726.
- [Groza, 07] Groza, T., Handschuh, S., Moeller, K., Grimnes, G., Sauer mann, L., Minack, E., Mesnage, C., Jazayeri, M., Reif, G., Gudjonsdottir, R. 2007, *The NEPOMUK Project - On the way to the Social Semantic Desktop*. Proceedings of I-Semantics' 07, pp 201-211.
- [Moran, 05] Moran, T.P., Cozzi, A., Farrell, S.P. 2005, *Unified Activity Management: Supporting people in e-business*. Communications of the ACM, 48(12).
- [Nepomuk, 06] NEPOMUK Deliverable D3.1 Task Management Model.  
[http://nepomuk.semanticdesktop.org/xwiki/bin/download/Main1/D3%2D1/D3.1\\_v10\\_NEPOMUK\\_Task\\_Management\\_Model.pdf](http://nepomuk.semanticdesktop.org/xwiki/bin/download/Main1/D3%2D1/D3.1_v10_NEPOMUK_Task_Management_Model.pdf). Accessed 2007-12-01.
- [Ong, 07] Ong, E., Grebner, O., Riss, U.V. 2007, *Pattern-Based Task Management: Pattern Lifecycle and Knowledge Management*. In Proceedings of WM2007. Mar. 2007.
- [Riss, 05a] Riss, U. V., Rickayzen, A., Maus, H., van der Aalst, W. M. P. 2005, *Challenges for business process and task management*. Journal of Universal Knowledge Management. J.UKM 0(2) (2005), pp. 77-100.
- [Riss, 05b] Riss, U. V. 2005, *Knowledge, Action, and Context: Impact on Knowledge Management*. In: K.-D. Althoff, A. Dengel, R. Bergmann, M. Nick, T. Roth-Berghofer (Eds.): Professional Knowledge Management, LNAI, vol. 3782, 598-608.
- [Riss, 07] Riss, U. V., Cress, U., Kimmerle, J., Martin, S. 2007, *Knowledge transfer by sharing task templates: two approaches and their psychological requirements*. KMRP 5, 287-296.
- [Sauer mann, 05] Sauer mann, L., Bernardi, A., Dengel, A. 2005, *Overview and outlook on the semantic desktop*. In Decker, S., Park, J., Quan, D., and Sauer mann, L., editors, Proceedings of the First Semantic Desktop Workshop at the ISWC Conference 2005.
- [Sauer mann, 06] Sauer mann, L. 2006, *PIMO-a PIM Ontology for the Semantic Desktop* (draft). Technical Report, 2006.  
<http://www.dfki.uni-kl.de/~sauer mann/2006/01-pimoreport/pimOntologyLanguageReport.html>. Accessed 2007-09-01.

# **The BREIN-Roadmap with PROMOTE<sup>®</sup>: A Use-Case Scenario of a Service-Based Knowledge Management Approach**

**Robert Woitsch**

(BOC Asset Management GmbH, Vienna, Austria  
robert.woitsch@boc-eu.com)

**Andrea Leutgeb**

(BOC Asset Management GmbH, Vienna, Austria  
andrea.leutgeb@boc-eu.com)

**Abstract:** BREIN is an FP6 EC-Project dealing with the development of an intelligent grid infrastructure. A key knowledge management challenge to be addressed within the project is the distribution of the results from the project to the software development community, in order to foster the usage of the BREIN middleware. Therefore this project introduces the BREIN Roadmap. The Roadmap is realized applying the knowledge management approach PROMOTE<sup>®</sup> that enables the knowledge transformation and distribution.

**Keywords:** Knowledge Services, Service Virtualisation, Service-Based Knowledge Management

**Categories:** M.1, M.2, M.5

## **1 Introduction**

This paper presents a use case of a process oriented Knowledge Management (KM) Approach with PROMOTE<sup>®</sup> [Woitsch, 04] in a service oriented use case environment - the EU-Project BREIN [BREIN, 08]. BREIN is an Integrated Project consisting of 17 partner organisations with a focus on developing an “intelligent” grid infrastructure (intelligent autonomous resources, simplifying communication and coordination, optimising business execution, etc.) [Bai, 05], [Terracina, 06]. One of the key challenges is to distribute the results and insights from the project to the outside software development community, in order to foster the usage of the BREIN middleware and ensure sustainability of the project. The distribution and explanation of the BREIN middleware requires a knowledge transformation from the software developers that are currently involved in the project towards potentially interested software developers outside the project. Here the project faces three main challenges: First, the existing knowledge on the BREIN middleware is multi dimensional, distributed and heterogeneous. Second, the knowledge transformation is expected from software development experts towards advanced and medium skilled developers. Finally, the third challenge is that knowledge that needs to be transferred is currently generated and situated within the project boundaries. The above challenges required a well-thought KM approach that enables the knowledge

transformation and distribution, as in this context: (a) multi-dimensional is seen as the different views on the BREIN middleware considering the user who use an application that is build on top of the middleware as well as the software developer that integrates a service into the middleware; (b) distributed is seen as different formats, tools, languages, responsibilities and work-style in a project consortium consisting of 17 partners from different countries; (c) different knowledge sources is seen as storage of knowledge in the local environment, company internal infrastructure, in source code or in the heads of the experts although advanced collaboration tools are used; (d) transformation from expert to advanced developers is seen as additional training element coupled with the knowledge transformation and finally, (e) the currently generated knowledge is in an early maturity level, often too early to be distributed with traditional knowledge instruments.

KM selected for this task offered the possibility to handle the specific issues of the described requirements in the area of intensive involvement of the knowledge in the production lines - such as software development and support it with the knowledge services and knowledge tools. PROMOTE<sup>®</sup> has been selected, based on the results of the Akogrimo-Roadmap [D 5.4.1, 05] [Woitsch, 06], as it allowed structured classification of the content and the used knowledge instruments.

The paper is structured as follows in the second chapter an overview on the PROMOTE<sup>®</sup> approach used to create the BREIN Roadmap is presented, focusing on the interpretation of the process oriented knowledge management and knowledge services virtualisation. In the third chapter the use case for the chosen KM within the BREIN Project is presented, describing the goals, the methods, the tools and current results of the BREIN Roadmap. After concluding this paper, an outlook is provided that introduces the idea of the knowledge bus as mentioned in the EC-Project MATURE [Mature, 08], which plans to use PROMOTE<sup>®</sup> to create a knowledge bus used for orchestrating available knowledge services[Bless, 08].

## **2 PROMOTE<sup>®</sup> - Process Oriented Knowledge Management: A Service-Based Approach**

### **2.1 Introduction into the PROMOTE<sup>®</sup> Approach**

PROMOTE<sup>®</sup> has been developed in the EU Project PROMOTE (1999-11658) and continuously improved in both commercial projects [Mak, 05] and EU co-funded research and development projects (Akogrimo [Akogrimo, 08], AsIsKnown [AsIsKnown, 08] and BREIN). Process-oriented KM has three different interpretations. The first interpretation is that processes are seen as content, using the graphical representation in combination with a textual description in order to make implicit organisational knowledge about working procedures explicit. The second interpretation sees processes as an the starting point for requirements that need to be fulfilled by the knowledge management system, similar to Model Driven Architecture (MDA). The functional specification of the KM-System is based on knowledge intensive activities within the process. The process acts therefore as an integration platform where the whole KMS is built around it. The third approach sees the process as a management instrument to define KM-Processes that coordinate the knowledge flow within an organisation.

The PROMOTE<sup>®</sup> methodology is based on the Business Process Management System (BPMS) methodology [Karagiannis, 02], [Junginger, 00]. This methodology guides organisations through developing KM strategy, designing, developing, and implementing a process based knowledge management system (KMS).

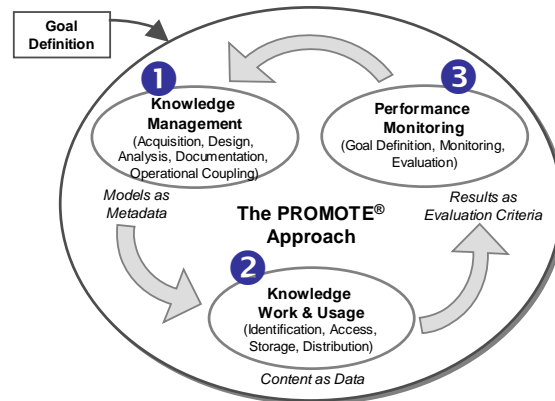

Figure 1: The PROMOTE<sup>®</sup> Approach

Within the PROMOTE<sup>®</sup> approach the goal definition as strategic decision enables the derivation of the requirements of the KMS. These requirements affect the first phase of the iterative cycle the Knowledge Management (1), where models are used to acquire, design, analyse and document. To reduce the complexity of modelling formal models, a graphical modelling environment is used. The design phase also includes the configuration and integration of knowledge products (e.g. Products presented in the Table 1). Therefore some of the knowledge products have to be virtualised to be provided as knowledge services. Operational coupling is used to transform the models for Knowledge Work & Usage (2), which deals with knowledge identification, access, storage and distribution. To enable a continuous improvement of the KMS, the results are evaluated (3). Therefore goals and criteria for performance monitoring and evaluation have to be defined. Finally, the results of the evaluation are used as input for further improvement thus leading to a continuous improvement cycle

## 2.2 Knowledge Services and Service Virtualisation

The term service in the context of service orientation refers to the well-defined principles encapsulation, loose coupling, contract, abstraction, reusability, composability, autonomy, optimisation and discoverability [Erl, 08]. So far the notion of “service” refers to a piece of software following specific characteristics. These services have a syntactical description but still miss a semantic definition.

The aim of knowledge services is to describe the service in the KM domain via semantics, thus bringing them to a higher level, to so called knowledge services. These services may be provided electronically or by humans, but require per se knowledge. To integrate also human services the concept of virtualisation is used to abstract everything that is a resource as a service.



Service virtualisation is closely related to Virtual Organisations (VOs), which enable disparate groups of organizations and/or individuals to share resources in a controlled fashion, so that members may collaborate to achieve a common goal [Foster, 01]. Sharing in this context means access to computers, data, software and other resources. The initially static collaborations have evolved and led to Dynamic VOs [TrustCom, 08], or were enhanced with the concepts of mobility [Akogrimo, 08], or business [BREIN, 08].

At runtime the services have to be dynamically orchestrated according to a defined process. To orchestrate services various mechanisms as provided by workflow engines or service discovery are used. Several levels of service discovery can be distinguished: First, on a technical level, local service discovery where networks or devices may be found. Second, web- and grid-service discovery where a concrete service for a workflow activity and a specific endpoint for the service has to be found. Third, application discovery where semantics are considered to perform the discovery process. The principles of application discovery and service virtualisation were applied in the project LD-CAST [Catapano, 08]. Here for non-technical users the implementation of the knowledge service is hidden. The user's interaction with the system will be described by business episodes that serve as coordination processes. When the user is performing a knowledge intensive task the system discovers supporting workflows related to the person and the specific task. This way the system supports the execution of processes in a user centric and flexible way, separating technical details from end-user requirements.

### **3 Use Case Scenario: BREIN Roadmap**

One of the key success factors for the BREIN project is to define how software can be implemented or be integrated to run using the BREIN middleware. The integration is concerned with the services that are part of the BREIN framework as well as applications that will run on top of it. The challenge is the appropriate knowledge provision to stakeholders that need to perform integration tasks. External existing applications are partly or entirely incompatible or overlapping to a large extent with the BREIN middleware. Hence there is need for an approach that provides the conceptual framework for the integration of BREIN in an existing environment and the development of new services and tools.

Therefore in BREIN, the Roadmap ("Roadmap to BREIN Convergence") will be implemented to tie together the methods, the tools and the conceptual framework. The Roadmap will provide the know-how to successfully integrate services into the BREIN framework. The motivation for the Roadmap was twofold, first the task of developing services for BREIN is highly challenging and knowledge intensive and second the knowledge needed for the task was situated only within the project consortium. As mentioned in the introduction the knowledge is often implicit and distributed over different sources, so the goal of the Roadmap is to organize it and facilitate the usage of the BREIN knowledge space for the consortium and for externals. Design and current usage of the Roadmap (as shown in the Figure 1) will be presented in the following two subchapters.

### 3.1 Design of the BREIN Roadmap

The BREIN Roadmap collects all steps necessary to develop services for the BREIN middleware or to integrate existing applications into BREIN. The Roadmap guides the user through necessary steps with the help of diagrams, code samples, descriptions and hyperlinks to related material. It will present this plan in a structured and graphical representation. Two Sub-Roadmaps have been defined: One to guide the development of new services within the BREIN framework and another to guide user in integrating existing applications or services.

These two Roadmaps will be realized following the iterative approach previously introduced in section 2.1. To generate the Roadmap top-down (starting from a rough view) as well as bottom up approaches (starting with existing knowledge resources) were considered. The Roadmap implements the documentation scenario of PROMOTE<sup>®</sup>, where the processes are seen as content of KM.

The Roadmap is used by the different user groups - business manager (BM), project manager (PM), the head of development (HD), Developer (D) and the integration team (IT) – using different products to reach their goals. Table 1 shows an the mapping of the identified products, the relevancy for the user groups and the service type (electronic (E) or human (H)).

Product	Description	User Group	Type
Graphical Roadmap Representation	A web user interface with a graphical Roadmap representation. Different entry points.	All	E
UML Repository	A collection of UML diagrams, concerning the architecture and specific components	HD, D, IT	E
Bug Report	A tool for the documentation of bugs	D, IT	E
Search Engine	A tool that allows advanced searching mechanisms within the Roadmap	All	E
Integration Report	A template to document integration efforts	D, IT	E
Document Repository	A repository containing best practise reports, manuals, documentation, etc.	All	E
Yellow Pages	A directory of experts, services, tools	All	E
Experts	Experts in a specific field, consortium partners with specialised expertise	All	H
Wiki	Application integration Wiki, BREIN Glossary	HD, D, IT	E
Mailing List	The BREIN mailing list	All	E
Documentation (Java-Doc)	A documentation of BREIN architecture components and their API	HD, D, IT	E
Introduction Videos	Introduction video for the BREIN architecture and each building block	HD, D, IT	E
Overview presentations	Introduction slides for BREIN relevant topics	All	E
Shared File Space	BREIN subversion system	All	E
Functionality Integration Template	A template defining a specific BREIN functionality and the integration steps necessary	HD, D, IT	E
Code Sample Repository	Collection of code samples, tips and example services	D, IT	E

Table 1: The BREIN Roadmap Products

The identified products were the starting point to build the Roadmap, as they are easy to understand and allowed to build up a KMS without being an expert. The identified products have to be virtualised (using wrapper approach) and provided as

knowledge services in order to make the system operational. Therefore for each product at least one appropriate tool had to be selected to be able to use it at runtime. As no tool exists that covers all requirements at least one tool was selected for each of the available knowledge products. The products are virtualised as knowledge services (virtual product). The service approach has the major benefit to be independent of system boundaries. PROMOTE<sup>®</sup> here supports the management of the knowledge services through the underlying models.

### 3.2 Current status of usage

After the initial phase of designing the BREIN Roadmap, the focus changed on supporting the three levels that will ensure sustainability and continuous usage of the Roadmap. The goal was to (1) keep and expand the community utilizing the BREIN Roadmap (starting from the consortium members and expanding to interested parties outside of the project), to (2) maintain and enhance existing content (knowledge space that meanwhile consists of more than one-hundred models, thousands of pages of deliverables and a lots of highly distributed knowledge) and finally to create easy to expand environment for adopting (3) new tools and technologies (integrating them in the BREIN Roadmap Products).

In order to fulfil these tasks a number of workshops were organized in order to establish common understanding, share views and prepare the BREIN Roadmap to be used by outside partners. Two of these workshops were necessary to define what the scope of the Roadmap should be and which questions it should cover. Starting with a top-down approach the following modelling sessions focused on defining the structure of the Roadmap in form of concept maps. Further five workshops were held to acquire the actual Roadmap processes that answer following BREIN related questions ( “What is the advantage to use BREIN?”, “How can existing application be integrated with BREIN?” and “How can new services for BREIN be developed?”). In the current status BREIN Roadmap is being used by the partners of consortium to develop new services for the BREIN Project and to prepare the BREIN Platform and the Roadmap for the inclusion of outside parties. Performance results of this stage will be monitored and evaluated (as depicted in the Figure 1) and provided as an input for the bootstrapping process in order to ensure the stability of the BREIN Roadmap.

## 4 Conclusions

The success of BREIN will strongly depend on its applicability and how existing solutions may be integrated with the BREIN framework. The need to make existing expert know-how explicit and to allow its usage by new developers as well as by potential adopters was satisfied by utilizing the PROMOTE<sup>®</sup> approach, and applying virtualisation of the knowledge available within the consortium to be able to offer it as a service for outside parties. Another experience was the comprehensiveness of the approach. Knowledge products as entry points were easy to understand and allowed the conceptual coupling of the system . The concept of knowledge services helped to make the system operational, as the system requirements and technical challenges are hidden. The system can be set up with different heterogeneous tools and can be used immediately and the system can be implemented in a stepwise manner

## 5 Future Work

As BREIN steps into its last project year, the Roadmap has been set-up and the knowledge collection and transformation started at the beginning of this year. Upcoming PROMOTE<sup>®</sup> developments must consider that KMS follow the overall trend towards service orientation, hence typical challenges in SOA are affecting PROMOTE<sup>®</sup>. One challenge in current software and service research is that business aspects get a tighter coupling with the technical aspects hence the Model Driven Approach becomes more important. The process is no longer a specification but evolves to an integration platform that is used for the system design, system requirement specification, system configuration via workflows and semi-automatically generated ontologies.

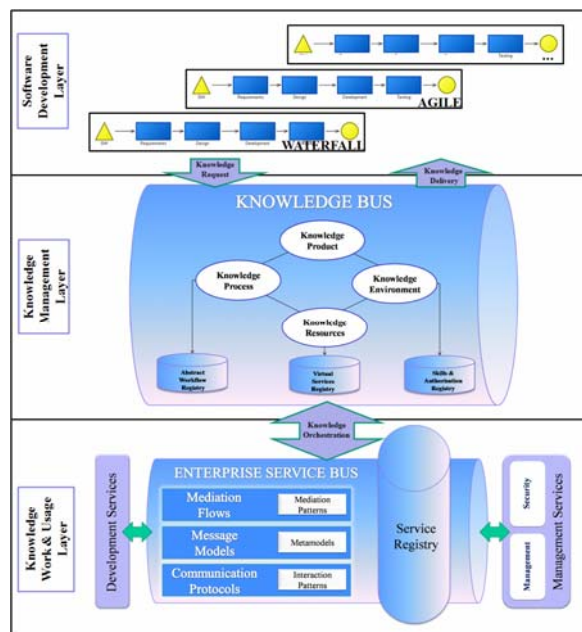

Figure 2: The Knowledge Bus Approach

Another important aspect is that the virtualisation of the services and resources in the knowledge management area is starting to be used in many application scenarios. Thus a need for a solution that involves some of the capabilities of the Enterprise Service Bus in the technical layer, but adds another important aspect – the Knowledge Bus – (as shown in the Figure 2) on the knowledge layer of the service oriented KMS, becomes reality.

Based on the results of BREIN in the recently started EU Project MATURE one of the tasks will be development and deployment of the Knowledge Bus in similar application scenarios involving orchestration and provision of access to the available virtualised knowledge services

## References

- [Akogrimo, 08] Akogrimo-Homepage, <http://www.mobilegrids.org>, access: 27.03.2008
- [AsIsKnown, 08] AsIsKnown-Homepage, <http://www.asisknown.org>, access: 27.04.2008
- [Bai, 05] Bai, X.; Yu, H.; Wang, G.; Ji, Y.; Marinescu, G.M.; Marinescu, D.C.; Boloni, L.; Coordination in Intelligent Grid Environments, Proceedings of the IEEE, Volume 93, Issue 3, March 2005 Page(s):613 – 630
- [Bless, 08] Patrick N. Bless, Diego Klabjan, Soo Y. Chang: Heuristics for automated knowledge source integration and service composition, April 2008, Computers and Operations Research, Elsevier Science Ltd, Volume 35 Issue 4
- [BREIN, 08] BREIN-Homepage, <http://www.eu-brein.com/>, access: 28.04.2008
- [Catapano, 08] Catapano, A., D'Atri, A., Hrgovcic, V., Ionita, A. and Tarabanis, K.: LD-CAST: Local Development Cooperation Actions Enabled by Semantic Technology. In Proceedings of the Eastern Europe e|Gov Days 2008, Prague, Czech Republic
- [D 5.4.1, 05] Deliverable 5.4.1, [http://www.akogrimo.org/download/Deliverables/Akogrimo-D5.4.1\\_v1.0.pdf](http://www.akogrimo.org/download/Deliverables/Akogrimo-D5.4.1_v1.0.pdf), access: 27.03.08
- [Erl, 08] Erl, T: Service-Oriented Design Principles, <http://www.soapprinciples.com/>, access: 28.04.2008
- [Foster, 01] Foster, I., Kesselman, C., Tuecke, S.: The Anatomy of the Grid: Enabling Scalable Virtual Organizations. International J. Supercomputer Applications, 15(3), 2001
- [Junginger, 00] Junginger, S., Kühn, H., Strobl, R., Karagiannis, D.: Ein Geschäftsprozessmanagement-Werkzeug der nächsten Generation – ADONIS: Konzeption und Anwendungen. In: WIRTSCHAFTSINFORMATIK, Vol. 42, Nr. 5, Vieweg-Verlag, 2000, pp. 392-401.
- [Karagiannis 02] Karagiannis D., Kühn H.: Metamodelling Platforms. In Proceedings of the 3rd International Conference EC-Web 2002 – DEXA 2002, Aix-en-Provence, France, 2002, LNCS 2455, Springer-Verlag, p. 182
- [Mak, 05] Mak, K., Woitsch, R.: Der Einsatz des prozessorientierten Wissensmanagementwerkzeuges PROMOTE® in der Zentralkommunikation der Landesverteidigungsakademie, Schriftenreihe der Landesverteidigungsakademie, 19/2005
- [Mature, 08] Mature-Homepage, <http://mature-ip.eu>, access: 28.04.2008
- [TrustCom, 08] TrustCom Project Homepage, [www.eu-trustcom.com](http://www.eu-trustcom.com), access: 28.04.2008
- [Terracina, 06] Annalisa Terracina, Stefano Beco, Tom Kirkham, Julian Gallop, Ian Johnson, Damian Mac Randal, Brian Ritchie : Orchestration and Workflow in a mobile Grid environment, October 2006, GCCW '06: Proceedings of the Fifth International Conference on Grid and Cooperative Computing Workshops, IEEE
- [Woitsch, 04] Woitsch, R., Karagiannis, D.: Process Oriented Knowledge Management: A Service Based Approach, In Proceedings of I KNOW '04, Graz, Austria
- [Woitsch, 06] Woitsch, R., Utz, W.: Roadmap to Akogrimo Convergence, A Sample of Process Oriented Knowledge Management with PROMOTE, In Proceedings of I KNOW '06, Graz, Austria

## **Workshop on Knowledge Acquisition from the Social Web**

### **KASW 2008**

**Andreas Hotho**

(University of Kassel, Germany  
hotho@cs.uni-kassel.de)

**Mathias Lux**

(Klagenfurt University, Austria  
mlux@itec.uni-klu.ac.at)

**Sergej Sizov**

(University of Koblenz-Landau, Germany  
sizov@uni-koblenz.de)

**Markus Strohmaier**

(Graz University of Technology, Austria  
markus.strohmaier@tugraz.at)

With the advent of the "Social Web", a new breed of web applications has enriched the social dimension of the web. On the social web, actors can be understood as social agents -technological or human entities- that collaborate, pursue goals, are autonomous, and are capable of exhibiting flexible problem solving and social behaviour. By participating in the social web, both technological and human agents leave complex traces of social interactions and their motivations behind, which can be studied, analyzed and utilized for a range of different purposes. The broad availability and open accessibility of these traces in social web corpora, such as in del.icio.us, Wikipedia, weblogs and others, provides researchers with opportunities for, for example, novel knowledge acquisition techniques and strategies, as well as large scale, empirically coupled "in the field" studies of social processes and structures.

This workshop aims to develop and bring together a diverse community of researchers interested in the social web and in understanding and evaluating the role of agents, goals, structures, concepts, context, knowledge and social interactions in a broad range of social web applications. Examples for such applications include, but are not limited to social authoring (e.g. wikis, weblogs), social sharing (e.g. del.icio.us, flickr), social networking (Facebook, LinkedIn) and social searching (e.g. wikia, eureka, mahalo) applications.

Recent problems of social network analysis are addressed by the contribution "Mining Socio-Semantic Networks Using Spreading Activation Technique" by Troussov, Sogrin, Judge, and Botvich (full paper). The aspect of information visualization in

Social Web environments is considered in the full paper "Visualizing Dynamics in Virtual Information Spaces" by Mueller and Kroeger. The role of Blogs for knowledge representation and acquisition is addressed by the position paper "Envisioning With Weblogs" by Gordon and Swanson. The position paper "Using Visual Features to Improve Tag Suggestions in Image Sharing Sites" by Lux, Marques, and Pitman, as well as the demo contribution "Harnessing Wikipedia for Smart Tags Clustering" by Grineva, Grinev, Turdakov, and Velikhov consider various aspects of knowledge-based tag recommendation for social content sharing environments.

The workshop KASW'08 is co-located with the Innovations Conference for Knowledge Management, New Media Technology and Semantic Systems (TRIPLE-I '08). The workshop program includes an introduction session, two research sessions with presentations of accepted contributions (2 full papers, 2 position papers, 1 demo paper), invited talks, and a round-table discussion on selected topics.

We anticipate that the increasing availability and accessibility of broad, socially-constructed knowledge on the web combined with the emergence of techniques and algorithms to acquire and structure this knowledge will fuel further research on the topics of this workshop. We expect that knowledge acquired from social web corpora can have deep implications for current research on ontology learning, common sense knowledge acquisition, the design of social web applications and social-focused navigation and search on the web.

## Organizers

- Andreas Hotho, University of Kassel, Germany
- Mathias Lux, Klagenfurt University, Austria
- Sergej Sizov, University of Koblenz-Landau, Germany
- Markus Strohmaier, Graz University of Technology, Austria

## Program Committee

- Anjo Anjewierden, University of Twente, Netherlands
- Ciro Cattuto, ISI foundation, Italy
- Andrew Gordon, University of Southern California, USA
- Ralf Klamma, RWTH Aachen, Germany
- Sotirios Liaskos, York University, Canada
- Henry Lieberman, MIT, USA
- Claudia Müller, University of Potsdam, Germany
- Kotaro Nakayama, Osaka University, Japan
- Sebastian Schaffert, Salzburg Research, Austria
- Arno Scharl, Modul University Vienna, Austria
- Marc Spaniol, MPII Saarbrücken, Germany

# **Mining Socio-Semantic Networks Using Spreading Activation Technique<sup>1</sup>**

**Alexander Trousov**

(IBM Dublin Software Lab, Ireland  
atrousso@ie.ibm.com)

**Mikhail Sogrin**

(IBM Dublin Software Lab, Ireland  
sogrimik@ie.ibm.com)

**John Judge**

(IBM Dublin Software Lab, Ireland  
johnjudge@ie.ibm.com)

**Dmitri Botvich**

(Waterford Institute of Technology, TSSG, Ireland  
dobtvich@ie.tcg.org)

**Abstract:** A mining method for egocentric and polycentric queries in multi-dimensional networks is proposed. The method allows fast search for objects in sufficient proximity of other object(s) where the proximity is defined in terms of multiple relationships between objects. The method uses spreading activation technique. Other potential uses of spreading activation technique are also outlined and, in particular, include applications to collaborative filtering (community detection based on tag recommendations, expertise location, etc). Moreover, the spreading activation technique is combined with so-called ambient navigation. The advantages of such approach are high performance and high scalability in terms of size of multi-dimensional network. The proposed method is very practical and is implemented in IBM LanguageWare software products.

**Keywords:** Spreading activation, social web, semantic web

**Categories:** H.3.1, H.4.1, H.5.2, H.5.3, I.2.7, I.5.3, L.1.3, L.1.4, L.6.1, L.6.2

## **1 Introduction**

The proliferation of Web 2.0 has brought together people and all kinds of digital artefacts: documents, concepts, vocabulary, tasks, activities, and more. The Web is increasingly becoming a participatory, social space which has established notions such as tagging as a popular mechanism to replace hierarchical categorization and formal ontologies.

A type of Socio-Semantic Web is emerging. It focuses on personalization, collaboration, findability and navigation, and bottom-up conceptualization. This web

---

<sup>1</sup> This material is based upon works supported by the European Commission under the Nepomuk project FP6-027705.



is a multi-dimensional network which connects people and the things they create and do. Each dimension of this emerging web represents different types of data with different types of relationships. Semantic Web techniques which allow us to specify types of these links, and how to use them are also suited for use in this field.

In this paper we'll discuss how technique of spreading activation helps in creating solutions for these types of multi-dimensional networks (people, documents, tasks, etc.). We'll illustrate this using as an example some new technology based on spreading activation developed by IBM LanguageWare which provides an integrated platform for combining social computing, semantic processing, and activity-centric computing for enhanced user experience.

This paper is organised as follows: in Section 2 we describe the spreading activation technique, Section 3 describes the initial input, and Section 4 describes how we can use the results and "tune" for specific tasks.

## 2 Spreading Activation Technique

Cognitive psychology and artificial intelligence research model reasoning and memory as processes on neural networks. These networks of neurons and the patterns in which they fire simulates certain aspects of the human brain. There are many different algorithms and implementations which model these processes, one of which, spreading activation, we use to mine information from multi-dimensional network data such as socio-semantic networks [Anderson,83].

Our approach focuses on using multi-dimensional networks comprised of concepts which represent actors (people, organisation, etc) and various digital artefacts related to the things they create and do, these concepts (nodes) are linked together by various socio-semantic links which represent relationships between concepts. Nodes and links in these networks may be typed and weighted, which allows great expressivity and applicability to various data and scenarios.

In general, the spreading activation algorithm proceeds as follows:

1. Initial activation is set to one or several nodes in the network (e.g. with value 1.0). This initial activation may represent items of interest, context of a document, user profile, etc.
2. Activation is spread to neighbouring nodes, but the activation value is normally less than the value of a source. For this, an activation decay parameter is introduced, usually in the range [0...1]. As the activation spreads through the network, different link types may have associated different decay values allowing for different effects like a lower rate of decay through "preferred" links.
3. If activation is spread from a node with many links, those neighbouring nodes will get even less activation to simulate a situation that many similar items get less attention when compared to one unique item.
4. However, if there are multiple paths in the network to some node, its activation will be sum of activations from its inputs. And therefore, it may get activation value even higher than the source.
5. After all activation values are calculated, they are ranked and nodes with higher activation represent important or interesting items or concepts.

We implemented a spreading activation algorithm in our Galaxy application, available from the IBM AlphaWorks site<sup>2</sup>. It contains a Java library for spreading activation and graph mining, as well as a GUI application based on Eclipse RCP.

Initial and final activation can be seen as functions on the network (e.g. real-valued function on nodes of the network), and spreading activation algorithms as a transformation from initial to final functions. It also allows us to “smooth” the initial activation function and get “highlights” or areas where activation peaks.

For example, in [Kinsella,07], we demonstrated that initial activation on four corners of a small grid might detect the centre of the grid. Some other examples will be presented later in this paper.

Superficially, the Galaxy UI appears like Google Sets<sup>3</sup>: the user focuses on one or more concepts and Galaxy tries to predict other concepts of interest (by returning the ranked list of the most activated nodes). However, unlike Google Sets, Galaxy can return results which are not necessarily in the same set of objects as the input, but which are still related. For example, given the input “red,” “green,” “orange” Galaxy might return a list of other colours, but it can also return concepts which are related, but not necessarily colours, such as “traffic lights.”

### 3 Processing egocentric and polycentric queries

Spread-of-activation might be used to provide rapid egocentric and polycentric search: query for search is expressed by placing initial activation in the nodes of interest; the result is the list of other nodes on network, ranked according to the cumulative strength of their connection to the initially activated set of nodes.

Here, we provide illustrative numerical simulations for typical small graph clusters. The nature of the spreading activation implementation we use means that the results in large scale graphs which have similar clusters contained within them as sub graphs will be similar. In the section 3.1 we provide considerations regarding cognitive value of the results of egocentric queries. In the section 3.2 we discuss applications of polycentric search. These results might be used for search and navigation in the multi-dimensional networks.

#### 3.1 Egocentric Querying

By providing activation to a single node of interest in the network and allowing the activation to propagate through the network the result is a low level analysis of what concepts (nodes) are closely related to the node of interest. This analysis is derived based on the existing relationship links in the network and the cumulative strength of activation spread through these various links. The objective of such egocentric queries is to derive an overview of the most relevant available content relating to a particular node or concept based on the data encoded in the semantic network.

[Kinsella,07] describes how egocentric queries on a social network can be used to find areas of interest, people and documents relating to individuals but which are not explicitly linked to that individual. Here, we approach egocentric queries from a

---

<sup>2</sup> <http://alphaworks.ibm.com/tech/galaxy>

<sup>3</sup> <http://labs.google.com/sets>

different point of view and show how we can use this approach to acquire additional knowledge from the network about the topic of interest of the egocentric query.

To illustrate this we use a rather simple example to show how the process works. In our example the socio-semantic network contains a person who is connected to some other people, who are researchers. Depending on the configuration of the network we would like to be able to use an egocentric query with Galaxy to extract the information that our person of interest is connected to other people or simply to researchers. Figure 1 illustrates this scenario.

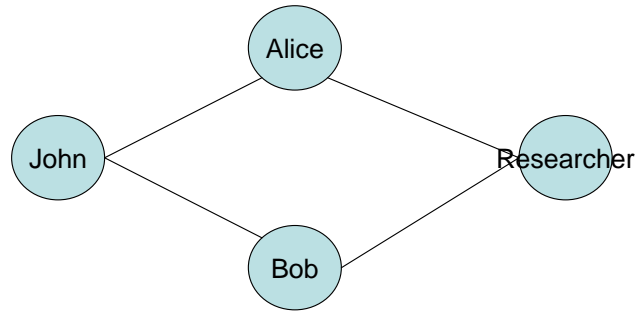

Figure 1: John is connected to two people who are researchers

Given a network like that in Figure 1 if we perform an egocentric query on the node labelled “John” it would not be unexpected that Galaxy would return “researcher” as a node which is related to John, but it would be unexpected for “researcher” to be favoured over the other two nodes in the network. That is to say that based on the information encoded in the network that we would not expect a response to our egocentric query to generalise and favour saying that “John is connected to researchers” over saying “John is connected to Alice” or “John is connected to Bob.” Figure 2 shows the activation values returned when we query such a network with Galaxy.

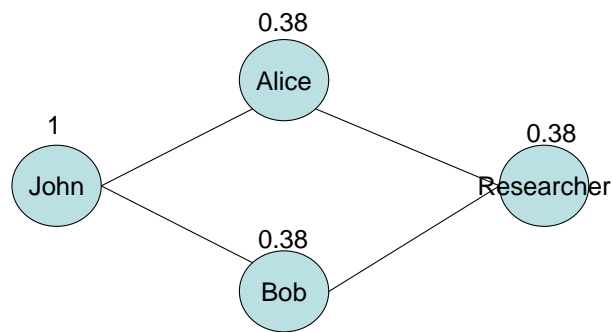

Figure 2: Activation values after egocentric query for “John” which was expressed by placing initial activation with the value 1.0 in the node “John”

The activation values shown in Figure 2 show that Galaxy has performed an accurate analysis of the network and determined that a relationship exists between “John” and his immediate neighbours in the network, that an indirect relationship exists with the concept “researcher” and that none of these relationships can be deemed to be stronger than the others based on the data in the network. This is a somewhat simplified example, however if we expand the network by introducing some more nodes as in Figure 3 we can make some interesting observations.

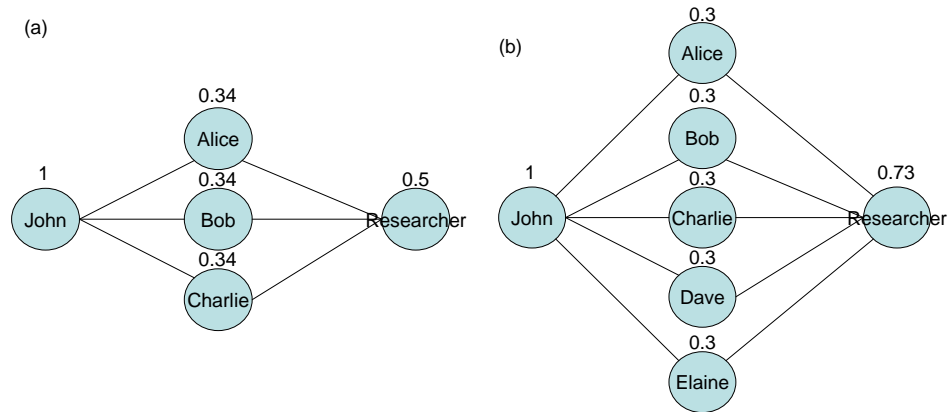

Figure 3: Egocentric query on larger networks

The graphs in Figure 3 show that as the number of intermediary nodes increases the activation level in the general category “researcher” increases while that in the individual nodes for each person is only slightly reduced. This is a desirable result because under these circumstances the nodes linked to “John” can be generalised more completely by the concept “researchers.”

### 3.2 Polycentric queries

An extension of simple egocentric queries, polycentric queries are those where initial activation is provided to multiple nodes in the network. These type of queries allow us to discover a wider range of new facts from the network data. The activation spreading from multiple simultaneous egocentric queries combines and accumulates in certain nodes which can increase the overall ranking of some nodes which would previously have had very little activation, and so would have been ranked lower. In this way by activating two or more nodes at the same time we can find nodes representing people, interests, documents etc., which are directly and indirectly related to both concepts and then use their relative activation levels to rank them according to their relevance to the overall polycentric query instead of to an individual egocentric query. This allows us, for example, to find people who are related to a series of documents, or to locate experts on a given topic who are in an individual’s social network.

## 4 Ambient Navigation

Today's applications which provide access to information typically use two navigation methods, *browsing* and *search*. A browser provides a number of links to other items or documents, while a search system shows relevant items given user's query.

We introduce a new navigation method in the socio-semantic space named *ambient navigation*, which utilises semantic network and user's context. It provides the convenience of having items presented in a way tailored to a particular user, situation, activity or context, but retaining a freedom of browsing.

Ambient navigation in our implementation is on-the fly transformation of the underlying semantic network (or ontology) in such a way that users can focus on one or more nodes (concepts) in the network, and immediately see a conceptual summary of their focus, in the form of transformed reduced network, in which unrelated items will be pruned (but not removed completely) and highly relevant items will be brought to the user's attention even if they were not explicitly linked to current user's focus. So users can navigate the information in a guided yet unconstrained way.

Ambient navigation is our user-centric generalisation of the theoretical approach which some research calls "dynamic taxonomies" [Sacco,00], but we don't restrict ourselves to hierarchical structures and facets. This kind of navigation is fast and easier for users to perceive, contextualise, simplify, and make sense of otherwise complex interlinked data without cognitive load.

### 4.1 Applicability of ambient navigation to collaborative tagging systems

Collaborative tagging or bookmarking systems like Del.icio.us or IBM's dogear are currently growing in popularity. They allow users to bookmark and tag web resources as well as view other people's bookmarked resources and tags.

All the data describing a given instantiation of a collaborative tagging system can be viewed as networks, where users, resources and tags are related by instances of tagging. Using this network, Galaxy can be used for a variety of scenarios:

- *Community detection*: Galaxy can find a community of people who relate to some other people when they tag similar resources with similar tags, therefore having similar interests or expertise. But community detection can also be used with regard to specific web resources or tags, or even any combination of them. When community detection is performed based on the current focus of a tagging system's user, it represents an example of ambient navigation by presenting useful contextual information and guiding a user to something that may be interesting for him.
- *Tag recommendation*: When tagging a web resource, a user may be presented with recommended tags based on his community. It would not simply present most frequent tags, but select ones that are used for that resource by people in his community.

The aim of ambient navigation is not to make choices for the user, but to improve or speed up user's navigation decisions by providing the most probable answers and links which are most likely to be of interest.

All these are applications of polycentric queries, as an initial activation may be put into multiple items like resources and tags. For instance, social metadata (tag) recommendation may proceed as follows:

1. Put initial activation at a person and a resource, and then find other related people or community.
2. Put initial activation at the same resource and people from the community found in the previous step, and find what tags would be related to that resource.

In this example spreading activation procedure was “cascaded”, i.e. used several times with the results of a given run used as a basis for subsequent ones. In addition, intermediate results of calculations may be presented to the user in some form to provide a means of explanation as to why and how the given results were achieved.

## 5 Conclusions

Spread of activation is a useful technique which can be easily used to mine generic or specific data represented by networks such as social networks and the semantic web, or the emerging socio-semantic web. Our implementation can be optimised for a particular task using parameters for single acts of spread-of-activation, or through cascading the results of several activation passes. In addition to this, its relative simplicity makes it computationally efficient, scalable, and extensible.

Our implementation gives results which reflect the context accurately and which are based on the context of the query and the underlying socio-semantic network and which can be tuned to variety of tasks including social/collaborative bookmarking, community detection and expertise location, as well as many emerging tasks.

## 6 Future Work

We believe that solution to many tasks in socio-semantic can be viewed as navigation from one or more initial nodes to other sets of nodes. Spreading activation techniques are generic, extensible, scalable and applicable to a variety of those problems (especially as ambient navigation).

The downside of this generality is that because the algorithm is optimised for speed, tuning can be hard, even using parameters which are described in [Galaxy,07]. We plan to address this in our future work. Our set of parameters is explicit and our performance is fast, so there is great potential for supervised learning to optimise the parameters. Randomised search in the parameter space (e.g. using evolutionary computing techniques) could prove to be a promising solution.

Secondly, we have illustrated how simple cascading of the results of spreading activation improves robustness and allows the user to easily guide the process. There is a wealth of possibilities for developing applications using this method once we have established an effective means to tune the base parameters for each task.

**References**

[Anderson,83] Anderson, J.: A Spreading Activation Theory of Memory, *Journal of Verbal learning and Verbal Behavior* 1983, (22), 261-295

[Kinsella,07] Kinsella, S., Harth, A., Trousov, A., Sogrin, M., Judge, J., Hayes, C., Breslin, J., Navigating and Annotating Semantically-Enabled Networks of People and Associated Objects, In Proc. In Proceedings of Applications of Social Network Analysis ASNA 2007, September 2007

[Galaxy,07] IBM LanguageWare Miner for Multidimensional Socio-Semantic Networks, December 2007, <http://www.alphaworks.ibm.com/tech/galaxy>

[Sacco,00] Sacco, G.: Dynamic taxonomies: a model for large information bases, *Knowledge and Data Engineering, IEEE Transactions on* Volume 12, Issue 3, May/Jun 2000, 468 - 479

## Visualizing Dynamics in Virtual Information Spaces

Claudia Mueller

(University of Stuttgart, Germany  
cmueller@iits.uni-stuttgart.de)

Stefan Kroeger

(University of Potsdam, Germany  
kroegers@uni-potsdam.de)

**Abstract:** In this contribution Wikis are interpreted as social information spaces. These information spaces can be decomposed in different networks. Here, one network is introduced – the collaboration network. This network type exemplifies how dynamics in social information spaces can be analyzed. For this, different approaches of visualizing networks are explained. The chosen approach is applied in an descriptive study. The open community project Wikiversity is examined to introduce one possible analysis in SONIVIS:Tool – an open source network mining software.

**Key Words:** Social Web, graph theory, network visualization, Wikis

**Category:** A.1, H.0, H.4.3, H.4.m, J.3, K.4.2, K.4.3

### 1 Emerging Sociability in the Web

During a conference brainstorming session, Tim O'Reilly and others have coined the term "Web 2.0". They wanted to characterize new techniques and services in the World Wide Web (WWW) [O'Reilly 2005]. But soon, this term was also applicable to a changing behavior of WWW users. More and more, the Web becomes a mirror image of the real world. With the dissolving cyber world the real social identity of an individual is transferred to a virtual equivalent. Meanwhile, the term "Social Web" is often used to describe this development. Here, Social Software plays an important role. Various applications are counted among it. One of them are Wikis. A Wiki is a *"freely expandable collection of interlinked Web pages, a hypertext system for storing and modifying information a database, where each page is easily editable by any user"* [Leuf and Cunningham 2001]. Wikis can be seen as social information spaces, which are formed by activities of authors and their content contributions. Existing dynamics in such information spaces are already investigated in terms of a temporal analysis of the Wikigraph [Buriol et al. 2006] or spatiotemporal knowledge visualization [Klamma et al. 2007]. Here, an new approach is introduced. This paper is organized as follows: first of all, a short introduction in the graph theory is given to describe collaboration networks in Wikis. Then, different approaches of visualizing dynamics in networks are explained. After an overview about the functionality of SONIVIS:Tool, an descriptive study is carried out.



Important developments in the Wikiversity project are illustrated and results of a time frame based network visualization are shown. This contribution closes with some conclusions and remarks about future work.

### 1.1 Applying graph theory

In Wiki-based information spaces, three domains can be defined: persons, knowledge/information, and tasks. Different perspectives can be specified based on these domains [Müller and Meuthrath 2007]. Every perspective contains at least one network and this networks supplies the context of interpretation. All networks in these perspective are interdependent [Carley 2003]. Here, one network definition is introduced more precisely – the collaboration network. Collaboration networks describe collaboration of authors on Wiki-pages. For example, author  $A_1$  changes page  $N_1$  at a particular time. After that another author  $A_2$  changes this page  $N_1$  at another time too. Therefore these two authors collaborate asynchronously. Collaboration networks can be formally described by applying graph theory. A collaboration network  $G_{CN}$  is an undirected graph. It consists of a set of authors (vertices)  $V_A$ . An author  $A$  is connected to an author  $B$ , when both authors revised the same Wiki-page  $E_C$ . In addition the collaboration network is a weighted graph. Each edge has a specific weight based on the number of collaborations  $W_{REV}$  of its connected authors. The combination of these three elements leads to the following description:

$$G_{CN}(V_A, E_C, W_{REV}), \{A_1, A_2\} \subseteq V_A \text{ of two actors } A_1, A_2 \text{ with } A_1 \neq A_2.$$

The objective of analyzing collaboration networks is to investigate the nature and extend of collaboration between persons in social information spaces.

## 2 Analysis of dynamics in collaboration networks

Basically, static and dynamic network visualization approaches can be differentiated. Static analysis deals with data which are accumulated over a specific time period. The network is visualized in a specific time frame (cp. [Gloor et al. 2003], [Moody et al. 2005], [Trier et al. 2007]). This time frame is part of a major time interval. Single vertices and edges are visualized, when the time frame is located in the interval of activity. The dynamic perspective of network analysis deals with the progression of state changes over time and enables the observation of events and its analysis. Dynamic network analysis allows for analyzing network states, vertices and their edges as well as changes in structure and configuration of the network [Carley 2003]. There are two kinds of visualizing dynamics in networks – cumulative analysis and sliding-window based analysis [Moody et al. 2005]. Their differ in the way of recording the network respective network parameters.

Cumulative analysis includes the aggregation of all changes and elements in a network over a long time period. The recorded strip can be interpreted as a complete image of the network. The network is growing over the period of time until it reaches the current state of the original network. All events in the considered interval are aggregated in one graph. The graph has an infinite memory of all active vertices and edges in the past and grows up to its final size which is equal to the static network's size at this time. In opposite to static network analysis, the network is investigated at different moments. Changes in the network structure are visible, but the sequence and existing interdependencies in network processes are not identifiable [Moody et al. 2005]. It is not sufficient to collect network information at different moments and then to subsume them [Doreian and Stokman 1997]. Events are not deterministic – they are stochastic. If two or three measuring points are selected randomly, then no or only unimportant events might occur. A evenly distribution of measuring points is possible, but it is without any sense, if all events happen at the same time. Therefore, another approach is applied here – the sliding-window. In the sliding-window based approach, a small period of time of the network or a sub-network is analyzed. A visualization of network data is carried out by a continuous time interval. The network is completely detached and based on single events. A sequence of these events can be evaluated based on time of occurrence and rhythm. Events can be specific attributes or positional changes. The size of the time frame depends on the number of occurred events. Only events in a specific time frame are aggregated to a network. The main objective of such investigation is to identify the impact of previous events on following events.

## 2.1 Analyzing information spaces using SONIVIS:Tool

Besides the specification of a visualization approach, a tool – SONIVIS:Tool – is developed<sup>1</sup>. SONIVIS:Tool is a Java-based open source software, which is based on Eclipse Rich Client Platform (RCP). Network visualization is implemented using the Prefuse Visualization Toolkit and metric calculation is done by GNU R, an open source software environment for statistical computing and graphics. The SONIVIS:Tool graphical user interface is based on completely configurable workspace layouts. At the moment, three main perspectives are predefined: *Analysis* (as standard perspective), *Manipulation*, and *Statistics*. The *Analysis* perspective contains different views, which provide users a quick overview about certain developments in Wiki information spaces. The *Manipulation* perspective allows for an enhanced visual manipulation of networks. There are three different layout algorithms implemented: Kamada-Kawai [Kamada and Kawai 1989], Fruchterman-Reingold [Fruchterman and Reingold 1991] and Circle Layout. A

---

<sup>1</sup> For more information have a look at <http://www.sonivis.org>.

visual filtering of the network is possible by minimal node degree and the minimal edge weight. Selected node metrics can be mapped on node size and color. Additional functions, like the network clustering, are offered.

### 3 Dynamic network visualization of Wikiversity

Wikiversity [Wikimedia Foundation, Inc. 2003] is a project of the Wikimedia Foundation. The objective of Wikiversity is *"to further the discovery and distribution of knowledge in a very natural way, by helping each other to learn."* [Wikimedia Foundation, Inc. 2003]. Important events of the German Wikiversity project are summarized in table 1.

Date	Event
2003-07	Idea of Wikiversity was published and discussed.
2005-02	First activities in the German Wikiversity.
2005-08	German Wikiversity went online.
2005-09-15 to 2005-11-01	Official poll about the autonomy of Wikiversity as a project ended.
2006-08-04	JIMBO WALES announced Wikiversity on the Wikimania conference.
2006-08-15	Launch of beta phase of English Wikiversity (6 month duration) was announced.
2006-08-24	Start of beta phase.
2006-08-25	Relaunch of the German Wikiversity.

**Table 1:** Important events of the Wikiversity project

In this explanatory scenario, the following question is answered: How do people work continuously in the Wikiversity project? Firstly, a copy of the database was download from the Wikimedia server [Wikimedia Foundation, Inc. 2008]. The first revision in the database was made on 2005-02-21 and the last revision 2008-02-05. In this period 70,929 revision where made and 29,322 links on 7,676 pages were created. The database size is about one gigabyte, whereas 13% are used by articles and 30% are used by discussion pages. 3,388 authors could be determined, whereof 1,212 are registered authors (35.8%). The Wikiversity project is a Wikimedia project, the platform is based on the MediaWiki software, which means that the data is stored in a MySQL database. In SONIVIS:Tool *DynamicCollaboration* is used as network type, the analysis period starts at 2005-02-20 and ends at 2008-02-06. Fruchterman-Reingold algorithm is used as visualization algorithm. The analysis period is divided into 36 time frames with an overlap of 5% of the frame size. The parameters form the configuration for the measurement and visualization with SONIVIS:Tool. In earlier analysis a number of 36 was evaluated as a good compromise between number of events per time

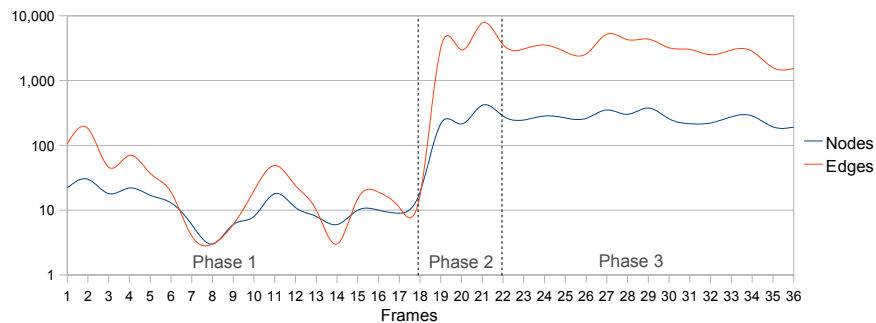

Figure 1: Development of number of vertices and edges in the investigated period (2005-02-21 to 2008-02-06)

frame and rate of changes over time [Moody et al. 2005]. The average size of time frames is about one month. The overlap is used to avoid information loss at the time frame borders [Bender-deMoll and McFarland 2006].

Figure 1 shows the number of authors for every time frame. A visualized author (vertex) denotes that an author created or edited at least one article in the specific time frame. A strong increase of active authors can be recognized at time frame 18 (marked by left orthogonal dashed line) after a long time of less or no increase (time frames 1 to 17). The number continuously rises up from frame 19 until time frame 21 (marked by a second right orthogonal dashed line). After time frame 22 the number of authors stays on a high, but nearly constant level. Figure 1 gives a first impression of the evolution of network structure. Three phases of network evolution are visible. Also from the network visualization using SONIVIS:Tool changes of the network structure and number of authors becomes visible. The kind of visualization improves the recognition of changes in network topology. Figure 2 shows the visualization of time frame 17, 18 and 19. Especially the high increase of node count and edge count between time frames 18 and 19 suggests a transition in the network. It indicates a point in the evolution of this information space. Comparing these measuring results with information about the Wikiversity project (cp. table 1), we find a specific event which might cause these changes. The announcement of JIMBO WALES on Wikimania conference and the launch of the beta phase of Wikiversity in August 2006 have increased the popularity of the project. This assumption is supported by the activity measurement of the most active registered authors in figure 3. All authors which are active in more then four time frames are shown in this visualization. These are 103 of all registered users. In phase 1, only ten of them

edited or created articles. From phase 2 (after time frame 19) on the majority contributes content to Wikiversity.

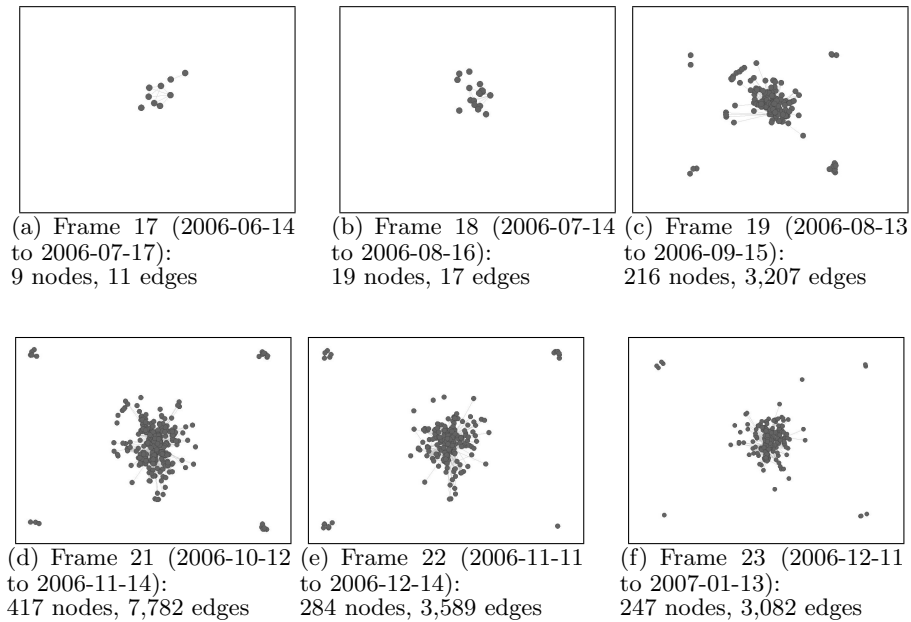

Figure 2: Screenshots of time frames 17, 18, 19 (above) and 21, 22, 23 (below) from dynamic network visualization of German Wikiversity

A second phase transition is visible between time frame 21 and 22, where the count of authors decreases slightly, but from this moment on stays on a high level. Later, changes are still minimal and an established amount of authors continuously work on the platform. Figure 2 shows the network visualizations for time frames 21, 22 and 23, where the number of authors decreased from over 400 (frame 21) to about 250 authors (frames 22 and 23). The comparison between the average node count of the phases substantiates this result. The average count of authors in phase 1 is 12, in phase two 257, and in phase three 246. In the beginning, the sliding-window based visualization of collaboration networks and the measured data show only few active authors. After a strong increase of active authors, the activity levels off at a continuous rate. Three development phases could be identified. Each phase outlines differences in the amount and intensity of authors work in the Wiki. Dynamic network visualization enables the identification of phase transitions. Additionally, user activities and their behavior in the social information space can be examined.



proved. Especially the influence of one author to another is an interesting question for further research. Dynamic visualization of the networks can be enriched by calculating and visualizing network metrics (e.g. centrality measures) and node metrics. In this way, more detailed information about reasons of network changes and influences on network structure and evolution can be uncovered.

## References

- [Bender-deMoll and McFarland 2006] McFarland, D. and Bender-deMoll, S.: “The Art and Science of Dynamic Network Visualization”; *JoSS: Journal of Social Structure* 2, 7, 2006, <http://www.cmu.edu/joss/content/articles/volume7/deMollMcFarland>.
- [Buriol et al. 2006] Buriol, L. and Castillo, C. and Donato, D. and Leonardi, S. and Millozzi, S.: “Temporal Analysis of the Wikigraph”; *Proceedings of the Web Intelligence Conference (WI 2006)*, Los Alamitos, CA, USA 2006, IEEE Computer Society [http://www.chato.cl/papers/buriol\\_2006\\_temporal\\_analysis\\_wikigraph.pdf](http://www.chato.cl/papers/buriol_2006_temporal_analysis_wikigraph.pdf).
- [Carley 2003] Carley, K. M.: “Dynamic Network Analysis”; *Dynamic Social Network Modeling and Analysis: Workshop Summary and Papers*, Committee on Human Factors, National Research Council 2003.
- [Doreian and Stokman 1997] Doreian, P. and Stokman, F. N.: “Evolution of Social Network”; Routledge 1997.
- [Fruchterman and Reingold 1991] Fruchterman, T. M. J. and Reingold, E. M.: “Graph Drawing by Force-directed Placement”; *Software - Practice and Experience* 11,21, 1991, 1129-1164.
- [Gloor et al. 2003] Gloor, P. and Laubacher, R. and Zhao, Y. and Dyne, S. B.C.: “Temporal Visualization and Analysis of Social Network”; MIT, Center for Coordination Science, Cambridge, MA 2003.
- [Kamada and Kawai 1989] Kamada T. and Kawai, S.: “An algorithm for drawing general undirected graph”; *Inf. Process. Lett.* 31,2, Amsterdam, The Netherlands 1989, 7-15.
- [Klamma et al. 2007] Klamma, R. and Cao, Y. and Spaniol, M. and Leng, Y.: “Spatiotemporal Knowledge Visualization and Discovery in Dynamic Social Networks”; *Proceedings of I-KNOW '07, 7th International Conference on Knowledge Management*, Graz, Austria, Sept. 5-7, 2007.
- [Leuf and Cunningham 2001] Leuf, B. and Cunningham, W.: “The Wiki Way - Quick Collaboration on the Web”; Addison-Wesley, New York 2001.
- [Moody et al. 2005] Moody, J. and McFarland, D. and Bender-deMoll, S.: “Dynamic Network Visualization”; *AJS Volume 110 Number 4*, 2005, 1206-1241.
- [Müller and Meuthrath 2007] Müller, C. and Meuthrath, B.: “Analyzing Wiki-based Networks to Improve Knowledge Processes in Organizations”; *Proceedings of 7th International Conference on Knowledge Management*, Graz, Austria 2007.
- [O'Reilly 2005] O'Reilly, T.: “What is the Web 2.0? Design Patterns and Business Models for the Next Generation of Software.”; 2005, <http://www.oreilly.de/artikel/web20.html>.
- [Trier et al. 2007] Trier, M. and Bobrik, A. and Bartels, T.: “Towards Understanding the Dynamics of Communication Networks”; *eOrganisation : Service-, Prozess-, Market-Engineering : 8. Internationale Tagung Wirtschaftsinformatik - Band 2*, Karlsruhe, Germany 2007, 593-610.
- [Wikimedia Foundation, Inc. 2003] Wikimedia Foundation Inc.: “Wikiversity (english)”; 2003, <http://en.wikiversity.org>.
- [Wikimedia Foundation, Inc. 2008] Wikimedia Foundation Inc.: “Wikimedia Downloads”; 2008, <http://download.wikimedia.org>.

## **Envisioning With Weblogs**

**Andrew S. Gordon**

(University of Southern California, Los Angeles, CA USA  
gordon@ict.usc.edu)

**Reid Swanson**

(University of Southern California, Los Angeles, CA USA  
swansonr@ict.usc.edu)

**Abstract:** In this position paper we present a vision of how the stories that people tell in Internet weblogs can be used directly for automated commonsense reasoning, specifically to support the core envisionment functions of event prediction, explanation, and imagination.

**Keywords:** Knowledge acquisition, Commonsense reasoning, Natural language processing

**Categories:** I.2.4, I.2.7, M.0

### **1 Commonsense Knowledge From The Social Web**

Commonsense reasoning was identified as a key problem in the field of Artificial Intelligence at its inception fifty years ago. Since then, the predominant approach to this problem has involved the logical formalization of commonsense knowledge. Although significant investment has been directed toward the authoring of formal content theories by professional knowledge engineers and researchers, only slow progress has been made toward the central goal of achieving broad-coverage commonsense formal knowledge resources [Davis, 2004]. The beginning of the current decade saw a shift away from the predominant approach, with the labor of commonsense knowledge engineering being distributed across members of large volunteer communities. Exemplified by the Open Mind Common Sense project [Singh, 2004], this work differed from the previous approach in three ways. First, natural language was used to represent commonsense knowledge, rather than logical notation. Second, knowledge bases were created as a product of contributions from thousands of (untrained) web volunteers. Third, new methods of automated reasoning were used to support commonsense inference in applications, instead of logically sound theorem-proving techniques. By pursuing a pragmatic approach to the problem of scale, this line of research has shown some success in integrating commonsense reasoning into real-world applications [Lieberman, 2004].

While the use of large volunteer communities is the most prominent characteristic of the approach, it is the use of natural language representations and alternative forms of inference that is now fuelling another shift in the way that commonsense reasoning research is pursued. The thousands of volunteers who contribute natural language to Open Mind Common Sense pale in comparison to the tens of millions of people who contribute natural language into their weblogs, online forums, and social networking websites. The Social Web has more breadth and depth of commonsense knowledge



than will ever be seen in hand-authored logical formalizations or in volunteer-contributed knowledge bases. This observation has recently spurred interest in commonsense information extraction from the web, where the *scruffy* text of social media is mined and repackaged into *neat* formalisms that can be used in traditional styles of automated reasoning. The fallacy of this approach is that using neat knowledge bases for general-purpose commonsense reasoning remains an unsolved problem, plagued by brittleness, the challenges of non-monotonic and default inference, and intractably large search spaces. Instead of squeezing the Social Web into the straightjacket of traditional approaches, we should be exploring ways to utilize its unique characteristics more directly in support of commonsense reasoning.

## 2 Envisioning With Weblogs

Reasoning about events and their causal and temporal relationships is the most central of all human cognitive abilities. Predicting the consequences of events in the world enables us to form expectations, identify potential threats to our goals, and consider alternative courses of action in the development of plans. Imagining the antecedent causes of events allows us to generate explanations for our expectation failures, and for the failure of our plans. Imagining events outside of our own experience enables our minds to wander into daydreams, consider the narratives of other people's experiences, and enjoy fictional stories. Collectively, these processes of event prediction, explanation, and imagination can be described using the umbrella term *envisioning*. Human-like Artificial Intelligence requires the development of robust general-purpose algorithms and formalisms for envisioning, and this has been the focus of most previous work in this area. However, human-like envisioning also requires a human-like model of how the world works, i.e. commonsense knowledge about the world in which people live. The lack of commonsense knowledge is one of the central reasons that we do not have successful envisioning systems today, and is subsequently a reason that we lack human-like artificial intelligence with the abilities to make explanations, draw expectations, devise plans in the real world, anticipate real-world threats, understand stories, and generate creative narratives.

Internet weblogs contain massive amounts of information about causal and temporal relationships between events in the world, contributed by tens of millions of authors. Much of this event information takes the form of first-person narratives of people's past experiences. The following (real) passage is typical of the stories found in weblog entries:

*"I cracked the egg into the bowl and then I saw it, yes a baby chicken was in the egg that was going to be our breakfast. I felt like I might be sick, but the rest of my family found this to be very interesting."*

This passage is particularly interesting from a research perspective because of a historical interest in the "egg-cracking problem," which served as a non-trivial benchmark problem in commonsense physical reasoning [Shanahan, 2004]. In its original form, the problem is to predict what would happen if the standard culinary practice of cracking an egg against a mixing bowl were changed in specific ways: What if the egg hits the edge of the bowl too quickly? What if the bowl is upside-

down? What if the egg is hard-boiled? Without resorting to logical formalization, this weblog author has just told us (in English) what happens when there is a live chicken inside the egg, namely that people will either feel like they might become sick or find it very interesting. In addition, the author has let us know that eggs turn into breakfast. Equally good answers for the original variants of the egg-cracking problem are readily available in weblog stories, with the exception of the most esoteric versions of the problem. The challenge we face is building new reasoning systems that can directly use this textual information in support of the basic processes of envisioning.

The genre of the everyday weblog story has both strengths and weaknesses as a source of commonsense knowledge, requiring that special consideration of the characteristics of this genre be taken into account. Schank & Abelson [Schank, 1995] have long argued that conversational stories of this sort are distinguished by the way that they violate commonsense expectations, suggesting that the knowledge extracted directly from stories may be the exact opposite of what is needed. This attribute is reflected in the egg-cracking passage above; we do not want to conclude from this text that baby chickens are expected to fall out of eggs that we crack. More subtly, there are a number of incorrect inferences in this passage that are more difficult to avoid: should we infer from this passage that people do not eat chickens? Problems of this sort have previously been used as a justification for the investing in the creation of hand-authored commonsense content theories. However, the massive scale of available content affords different approaches, e.g. the application of statistical, evidence-based techniques. To pursue these new approaches, however, the focus of research in the area of commonsense reasoning needs to shift toward a new set of research problems: story acquisition, story analysis, and story-based envisioning.

First, new story acquisition technologies are needed to automatically collect massive amounts of stories. Gordon et al. [Gordon, 2007] developed automatic techniques for extracting stories from weblog entries, where only 17% of the text is story-like in character. Using a machine learning text classification approach, this work obtained reasonable levels of precision and recall, but still much less than the inter-rater agreement among annotators of the training data. The further development of fast and accurate story acquisition techniques would allow for the creation and maintenance of extremely large corpora of textual stories from weblogs and other sources in the Social Web. The development of gold-standard training and evaluation corpora with high levels of inter-rater agreement would facilitate progress in this area.

Second, some amount of syntactic and semantic processing of the natural language text of stories will be necessary, particularly to identify events within these stories and the causal and temporal relationships between them. For some envisioning tasks, it may be reasonable to simply assume that sequences of story sentences map directly onto ordered sequences of events in the world. For envisioning that requires more precision, it may be advantageous to explicitly delineate events in narrative text and identify the semantic relationships between them. Recent work in this area has focused on machine learning approaches using annotated training corpora, e.g. TimeML annotations of news articles [Mani, 2006]. The utility of this technology in support of commonsense reasoning could be improved by shifting attention away from news article text and toward the stories of people's experiences, as can be found on the Social Web. Many of the existing event-analysis technologies would be

suitable for this genre, but would require the development of new training and evaluation corpora of annotated story text.

Third, new methods are needed to use the event sequences identified in stories to support automated commonsense reasoning. The basic reasoning tasks of envisioning (prediction, explanation, imagining) each require the capacity to produce a new event with a specific semantic relationship, given a state or event description as input. One strategy is to learn a model of event transitions using stories on the Social Web as training examples. This approach is exemplified in the work of Manshadi et al. [Manshadi, 2008], where language-modelling techniques were used to learn a probabilistic model of event sequences using stories extracted from weblogs. While this line of research is promising, we believe that alternative approaches to envisioning should also be explored. In particular, case-based reasoning techniques seem particularly well suited to this task, where event sequences serve as cases in an episodic memory, and the processes of envisioning are recast as textual retrieval and adaptation problems.

### **Acknowledgements**

The project or effort described here has been sponsored by the U.S. Army Research, Development, and Engineering Command (RDECOM). Statements and opinions expressed do not necessarily reflect the position or the policy of the United States Government, and no official endorsement should be inferred.

### **References**

- [Davis, 2004] Davis, E. & Morgenstern, L. (2004) Introduction: Progress in formal commonsense reasoning. *Artificial Intelligence* 153(1-2):1-12.
- [Gordon, 2007] Gordon, A., Cao, Q., & Swanson, R. (2007) Automated Story Capture From Internet Weblogs. 4th Intl. Conference on Knowledge Capture, Whistler, BC.
- [Lieberman, 2004] Lieberman, H., Liu, H., Singh, P., and Barry, B. (2004). Beating common sense into interactive applications. *AI Magazine* 25(4):63-76.
- [Mani, 2006] Mani, I., Verhagen, M., Wellner, B., Lee C., & Pustejovsky, J. (2006) Machine Learning of Temporal Relations. 46th Meeting of the Association for Computational Linguistics, Sydney, Australia.
- [Manshadi, 2008] Manshadi, M., Swanson, R., & Gordon, A. (2008) Learning a Probabilistic Model of Event Sequences From Internet Weblog Stories. 21st International FLAIRS Conference, Coconut Grove, FL.
- [Schank, 1995] Schank, R., & Abelson, R. (1995). Knowledge and memory: The real story. In Wyer (Ed.), *Knowledge and memory: The real story*. Mahwah, NJ: Lawrence Erlbaum.
- [Shanahan, 2004] Shanahan, M. (2004). An attempt to formalise a non-trivial benchmark problem in common sense reasoning. *Artificial Intelligence* 153(1-2):141-165.
- [Singh, 2004] Singh, P., Barry, B., & Liu, H. (2004). Teaching machines about everyday life. *BT Technology Journal* 22(4):227-240.

# Using Visual Features to Improve Tag Suggestions in Image Sharing Sites

**Mathias Lux**

(Klagenfurt University, Klagenfurt, Austria  
mlux@itec.uni-klu.ac.at)

**Oge Marques**

(Florida Atlantic University, Boca Raton, USA  
omarques@fau.edu)

**Arthur Pitman**

(Klagenfurt University, Klagenfurt, Austria  
apitman@edu.uni-klu.ac.at)

**Abstract:** Social media sharing sites such as Flickr or YouTube have become immensely popular. Besides sharing actual content, users also share annotations describing or classifying the contents they publish. Although tagging is easy, annotation still is a laborious task that can be made easier by suggesting meaningful additional tags to the user automatically. In this position paper we propose a system architecture and process for supporting annotation by tag suggestion to increase the quality and quantity of social annotations. The goal is not to tag previously untagged images in a completely automatic way, but instead to extend the amount and completeness of annotations by supporting the user in the process of adding further tags.

**Keywords:** Multimedia, annotation, tag recommendation, social software

**Categories:** H.3.3, H.5.1

## 1 Introduction

The amount of visual information available online is increasing rapidly. Flickr alone claims more than 5,000 uploads per minute to be viewed by an audience of millions. Still the task of finding images of interest remains as challenging as ever. A major difficulty in image retrieval is that most successful search engines rely on the presence of text associated with the images to be able to properly retrieve them. In case of social sharing sites, keywords usually appear as *tags* associated with the images. In a perfect world, all images would have a reasonable number of user-generated tags, which would then enable other users to find and retrieve them. In reality, however, only a small share of uploaded pictures are tagged. While in the early days of *content-based image retrieval* (CBIR) researchers thought visual features might tackle this problem, research was hampered by what became known as the ‘semantic gap’, which refers to the inability of a machine to fully understand and interpret images based on automatically extracted low-level visual features [Smeulders 2000]. The obstacles imposed by such a gap have limited the success of pure CBIR solutions to narrow domains.

Much of current research in visual information retrieval (VIR) is aimed at reducing the ‘semantic gap’ and incorporating textual information in order to improve the overall quality of the retrieval results [Datta 2008]. For several years, one of the most prominent obstacles for combining visual data and textual metadata was the long-held assumption that manual image annotation is too expensive, subjective, biased, and ultimately, not feasible. This assumption is now being challenged in many ways, from the availability of Semantic Web-related ontologies, to the popularity of image labelling games, to the willingness of users to annotate, tag, rate, and comment on pictures, enabled by social media sharing sites. The latter aspect, namely the availability of user-generated tags, combined with the successful track record of CBIR within narrow domains, has motivated this work: we want to extend annotation quality and quantity (in the number of tags assigned to an image) by tag recommendation. To do this we aim to identify ‘narrow domains’, select appropriate visual features automatically and use this knowledge to present users a ranked list of possible additional tags.

## 2 Related work

Tags assigned by users are often ambiguous, available in several languages or declinations and sometimes not even related to the image content at all [Golder 2006]. Despite these shortcomings, social tagging often leads to surprisingly good annotations extracted from a huge amount of annotated content due to the *wisdom of the crowds* effect [Guy 2006]. A central concept in collaborative tagging is that of *folksonomy*: the result of social annotation, a network of users, resources and tags [Mika 2005]. Also research efforts towards semantically-capable visual information retrieval systems have grown exponentially over the past five years. Some of these efforts are tied to Semantic Web standards, languages and ontologies [Hyvonen 2002], while others employ keywords in a loose way (not associated with any ontology or folksonomy) [Rasiwasia 2006]. Still others rely on tags (e.g., [Datta 2007]) and are therefore more closely related to the work proposed in this paper.

Especially relevant to the ideas presented in this position paper is the work described in [Kern 2008] proposing a tag recommendation system for images solely based on tag co-assignment analysis, which we plan to extend further. The approach of [Aurnhammer 2006] is also related to our work to the extent that they also postulate that a combination of content-based image features and tags enhances image management. However, while we focus on supporting the annotation process to improve and extend the quality of annotations, in [Aurnhammer 2006] the focus is put on reducing the negative effects of mistaken tags (typos and false tags), synonymy and homonymy for retrieval in image databases. Moreover, from a CBIR point of view, our proposed architecture extends the approach in [Aurnhammer 2006] towards current state of the art: we focus on automatic identification of best performing metric/feature combinations for narrow domains instead of defining features (and their combination) a priori.

### 3 Architecture for Semi-automatic Tag Suggestion

Figure 1 provides a general overview of the main user actions as well as the tasks to be performed by the proposed system. In our scenario we assume that a user tags an image with at least one input tag. Based on the input tag, related tags are selected solely based on tag co-occurrence. Based on a visual similarity analysis using low level visual features involving the input image against images tagged with related tags, the list of tag suggestions is then re-ranked to give higher priority to tags associated with visually similar images.

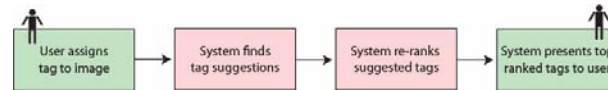

Figure 1: Overall process of the proposed system.

The re-ranking mechanism is the central and novel piece of the proposed architecture. Since this approach is only feasible for narrow domains – and different domains will call for different combination of feature vectors (descriptors) and dissimilarity metrics in order to be successful [Deselaers 2008] – our proposed system employs machine learning to train classifiers to accomplish this goal, namely, to discover the best combination of descriptors and dissimilarity measures for a certain combination of co-occurring tags, which should improve the chances of success of our classifiers.

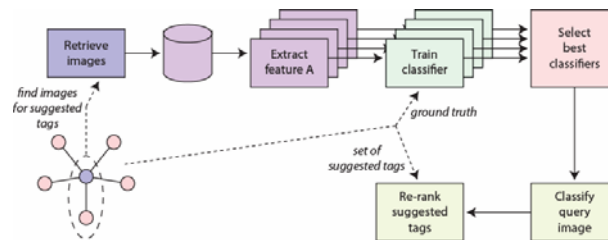

Figure 2: Flow diagram of the re-ranking step in the overall system design.

Figure 2 shows a schematic overview of the proposed re-ranking mechanism and its main steps. We assume that the co-assignment analysis of the input tag(s) results in an affiliation network depicting tag relations. The ego-centred network of the input tag of the user is the input to this process. For each tag related to the input tag, images tagged with *both* the input tag and the related tag (in a pair-wise fashion) are retrieved, resulting in  $N$  images per pair, which are stored locally for further visual analysis. For each of those images, visual features (e.g. colour histograms, texture or local features) are extracted by a set of independent feature extraction modules. Treating each tag pair and the corresponding retrieved images as a single topic, we train fuzzy classifiers for feature selection [Wu 2006] for each topic in the following way: for each available visual feature and metric combination a classifier is trained

and evaluated using cross-fold validation. Based on results from the cross-fold validation, the best performing feature/metric combination is used. The result of this procedure is a list of trained fuzzy classifiers. Each of them can be used to find the degree of membership of an image to a certain topic. Next, we return to the input image and use the best performing classifiers to determine its degree of membership. The degree of membership is then used as relevance function for tag suggestions.

## 4 Research Issues and Contributions

We want to increase quality and quantity of social annotations through the proposed tag suggestion system to support users in the annotation process. The proposed work focuses in particular on the usefulness of the combination of state of the art VIR methods and tag co-assignment analysis. We plan to answer following research questions:

- **Quality of suggestions.** Does our approach enhance the quality of tag suggestions? And if so, by how much?
- **Tag to image content correlation.** Does a significant subset of tags correlate to the image content? And if so, by how much?

As there is no gold standard for social media sharing we plan to evaluate our approach (i) user-centred and (ii) social annotation based, with the social annotations are considered as gold standard.

## References

- [Aurnhammer 2006] Aurnhammer, M., Hanappe, P., Steels, L.: "Integrating Collaborative Tagging and Emerging Semantics for Image Retrieval", Proc. Collaborative Web Tagging Workshop (WWW'06), 2006
- [Datta 2007] Datta, R., Ge, W., Li, J., Wang, J.: "Toward Bridging the Annotation-Retrieval Gap in Image Search", IEEE Multimedia, 24-35, 2007
- [Datta 2008] Datta, R.; Joshi, D.; Li, J.; Wang, J. Z.: "Image retrieval: Ideas, influences, and trends of the new age", ACM Computing Surveys 40, 2, p. 1-60, 2008
- [Golder 2006] Golder, S. A.; Huberman, B. A.: "The Structure of Collaborative Tagging Systems", Journal of Information Science 32, 2, 2006
- [Guy 2006] Guy, M., Tonkin, E.: "Folksonomies - Tidying up Tags?" D-Lib Magazine, 12, 1, 2006.
- [Hyvonen 2002] Hyvonen, E., Styman, A., Saarela, S.: "Ontology-based image retrieval", Proc. XML Finland 2002 Conference, 15-27, 2002.
- [Kern 2008] Kern, R.; Granitzer, M.; Pammer, V.: "Extending Folksonomies for Image Tagging", Proc. WIAMIS 2008, IEEE, Klagenfurt, 2008.
- [Mika 2005] Mika, P.: "Ontologies Are Us: A Unified Model of Social Networks and Semantics", Proc. International Semantic Web Conference, Springer, 522-536, 2005
- [Rasiwasia 2006] Rasiwasia, N.; Vasconcelos, N.; Moreno, P.: "Query by Semantic Example", Proc. of the International Conference in Image and Video Retrieval, 51-60, 2006

[Smeulders 2000] Smeulders, A.; Worring, M.; Santini, S.; Gupta, A.; Jain, R.; 'Content-based image retrieval at the end of the early years', *IEEE Transactions on Pattern Analysis and Machine Intelligence*, 22, 12, 1349-1380, 2000

[Wu 2006] Wu, K.; Yap, K.: "Fuzzy SVM for content-based image retrieval: a pseudo-label support vector machine framework", *IEEE Computational Intelligence Magazine*, 1, 2, 10-16, 2006



# Harnessing Wikipedia for Smart Tags Clustering

Maria Grineva, Maxim Grinev

Denis Turdakov, Pavel Velikhov, Alexander Boldakov

(Institute for System Programming of Russian Academy of Sciences  
Moscow, Russia

rekouts@ispras.ru, maxim@grinev.net

turdakov@ispras.ru, velikhov@ispras.ru, boldakov@ispras.ru)

**Abstract:** The quality of the current tagging services can be greatly improved if the service is able to cluster tags by their meaning. Tag clouds clustered by higher level topics enable the users to explore their tag space, which is especially needed when tag clouds become large. We demonstrate TagCluster - a tool for automated tag clustering that harnesses knowledge from Wikipedia about semantic relatedness between tags and names of categories to achieve smart clustering. Our approach shows much better quality of clusters compared to the existing techniques that rely on tag co-occurrence analysis in the tagging service.

**Keywords:** Wikipedia, User-generated content analysis, network analysis, tagging

**Categories:** H.3.3, H.3.5

## 1 Introduction

Tagging services that assign relevant keywords to documents or objects have become quite popular in the past few years. Currently tagging is an essential part of Web 2.0 applications such as social bookmarking services (Furl, del.icio.us), blogging (Technorati) and photo-sharing services (Flickr) [O'Reilly, 2005].

Tagging services provide their users with a repository of tagged objects - a *tag space* - that can be explored via *tag cloud*. Tag cloud is some kind of a visual depiction of a set of tags. Tags in a tag cloud are either listed alphabetically, or the size of tags in a tag cloud is proportional to their popularity. In practice, such tag clouds fail to help in exploration of the tag space when the number of tags becomes more a less significant (approximately more than 100). Improving search and exploration in tag spaces has been studied from different perspectives, among a variety of approaches we distinguish a simple yet promising idea that automatically dividing tag cloud into a number of semantically cohesive clusters would make it much more helpful for tag space exploration [Begelman, 2006], [Hassan-Monteroa, 2006].

In existing methods [Begelman, 2006], [Hassan-Monteroa, 2006], relatedness between tags is inferred by means of tags co-occurrence analysis of the tagging service repository: tags are considered related if they are assigned to a common object. However, this assumption is quite uncertain and as a consequence the methods often produce dirty clusters [Begelman, 2006]. In contrast, the key point of our approach is using Wikipedia to compute semantic relatedness between tags and to pick the names for the clusters and we demonstrate that this results in higher quality tag clusters.

## 2 Key Techniques

TagCluster processes tag cloud in three steps. The following key techniques are used in these steps:

- For each tag in the tag cloud we find its corresponding concept in Wikipedia. We use our Wikipedia-based disambiguation tool for proper handling of homonym tags. The disambiguation tool is described in [Velikhov, 2008].
- We create a weighted graph for the tags, where each vertex is the corresponding Wikipedia concept and each edge is the relatedness between concepts with the corresponding relatedness weight. Relatedness measure between Wikipedia concepts is computed as described in [Velikhov, 2008], [Lizorkin, 2008].
- We use Girvan-Newman community detection algorithm [Newman, 2004] to partition the graph into semantically cohesive subgraphs. For each subgraph we derive its topic: we compute centrality measures for its vertices, then collect the Wikipedia categories of the concepts (vertices) and rank them according to the concept's centrality measure. Categories with the highest rank constitute the community subgraph topic.

## 3 Demonstration

We demonstrate TagCluster on the del.icio.us tag clouds. We collect the tag cloud of any given del.icio.us user and perform the clustering. We show that our approach produces smarter clusters compared to existing approaches.

### Acknowledgements

The work is partially supported by grants of RFBR NN 08-07-00195 and 08-07-12010.

### References

- [Begelman, 2006] G. Begelman, P. Keller, F. Smadja. Automated Tag Clustering: Improving search and exploration in the tag space. In *Proc. of the WWW2006*
- [Hassan-Montero, 2006] Y. Hassan-Montero and V. Herrero-Solana. Improving Tag-Clouds as Visual Information Retrieval Interfaces *InSciT2006*, 2006
- [Lizorkin, 2008] D. Lizorkin, P. Velikhov, M. Grinev. Accuracy Estimate and Optimization Techniques for SimRank Computation. *To appear in VLDB '08*.
- [Newman, 2004] Girvan, M. and Newman, M. E. Finding and evaluating community structure in networks. *Phys. Rev. E* 69, 026113, 2004
- [O'Reilly, 2005] O'Reilly, T.: What Is Web 2.0. Design Patterns and Business Models for the Next Generation of Software. O'Reilly Radar report, 2005
- [Velikhov, 2008] P. Velikhov et al.. Efficient Ranking and Computation of Semantic Relatedness and its Application to Word Sense Disambiguation. *ISPRAS MODIS Technical report*, 2008

# **Becoming Knowledge Focused: Towards a Conceptual Definition of Knowledge Management in International Organizations**

**Ugo N. Ugbor**

(Center for International Knowledge Management  
Vienna, Austria  
uugbor@mac.com or uugbor@opec.org)

**Abstract:** This paper proposes a conceptual definition that can be used as a starting point to contextualize knowledge initiatives in international organizations and other types of non-profit organizations interested in knowledge management.

Organizational leaders, knowledge managers and consultants involved in creating and implementing knowledge management initiatives aimed at process improvements in international organizations context could benefit from the reflections and learning insights from this paper.

This paper does not address efficiency matters from the political or governing sphere, nor does it propose specific programmatic changes to work of international organizations; rather it presents a pragmatic “bottom-up” approach, based on case studies and interviews conducted at eight different international organizations, including the European Union (EU), the International Atomic Energy Agency (IAEA), the International Maritime Organization (IMO), the OPEC Fund for International Development (OFID), the Organization of the Petroleum Exporting Countries (OPEC), the Organization for Security and Co-operation in Europe (OSCE), the United Nations Industrial Development Organization (UNIDO) and the United Nations Office on Drugs and Crime (UNODC) and were classified according to their functional orientation. Over 40 interviews have been conducted, with organizational leaders, knowledge managers, IT managers and human resources managers.

The grounded theory methodology as described by Strauss and Corbin [Strauss and Corbin, 1990, Strauss and Corbin, 1994], using interviews and document studies for data collection, combined with findings from literature, helped identify processes involved in managing knowledge in international organizations.

**Keywords:** knowledge management, intellectual capital, international organizations  
**Category:** M.9

## **1 Introduction**

The interest in knowledge management has been growing rapidly throughout international organizations [CEB, 2005]. Yet a constant comment from existing and nascent international organizations' KM researchers and practitioners has been that, until now, most of the analytical literature concerning knowledge management has sought to understand and explain it within a mainly private sector context [Perkmann, et al., 2005]. Thus the application of KM expertise to international organizations has not been straightforward [CCPOQ, 2000]--only 2 of 17 international organizations surveyed reported “successful” results.

## 2 KM in business versus KM in international organizations

KM in businesses is generally driven by two factors: one is the competitive advantage that can be derived from knowledge [Stewart, 1998], and the other is the developments in information technology [Gallupe, 2001]. However, KM in international organizations can be driven by more complex factors. Firstly, there is a difference in the success criteria. While companies are established to generate tangible shareholder benefits, like profits and market share, international organizations are established to help generate intangible benefits for its various stakeholders, like promoting national and regional interests specifically and to improve international cooperation in general [UN, 1945, UN, 2000, UN, 2005].

Secondly, companies have a quicker feedback loop in the form of markets and profits. This makes them strive for increased efficiency [Hazlitt, 1988]. International organizations lack these kinds of short feedback loops—international agreements are made for long-term benefit. For example, the United Nations Millennium Development Goals (MDG)[UN, 2000] aims to secure peace and development, by addressing poverty, ignorance and preventable diseases. Furthermore, countries have exclusivity in official representatives at the governing sphere of international organizations, making the environment in which they operate abstract, impersonal and complex, rendering measurement of intangibles of international cooperation more difficult to articulate, locate and measure.

Thirdly, processes in the business sector are organized in order to achieve some concrete targets (like profit, or market share, and so on) at the end [Hazlitt, 1988]. However, processes and functions in international organizations are not instruments to an end, but have importance in themselves. For example, international conventions and treaties are important in themselves, even before countries ratify their proposals—the Kyoto Protocol [UNFCCC, 2007], remains an important objective, even though not all countries have ratified it.

Fourthly effectiveness in terms of stakeholder benefits is more important than efficiency in international organizations. In the business sector, a guiding principle is efficiency in resource utilization (i.e. productivity) [Hazlitt, 1988]. In international organizations, certain inefficiencies are necessarily built into the system through the diplomatic, political and bureaucratic forces of the system [Magarinos, 2005]—For example, the insistence principle of equality [UN, 1945] and the absence of intergovernmental agreements and coordination [Jackson, 1969].

These major differences between businesses and international organizations influence the application of extant knowledge management. In the business sector, knowledge has instrumental value, which is directly applied to particular products and/or services. In international organizations, knowledge has a more general application. It is often used indirectly, for normative and operational functions (cf.[Ugbor and Chanduvi-Suarez, 2007]), such as enabling the international community to react to changes in geopolitics, reaching common consensus on issues of global governance, and for providing services to enable countries meet internationally agreed standards.

### **3 Towards a conceptual definition of KM in international organizations**

International organizations' intellectual capital comprises of its member countries at the macro level, and individual specialists within and beyond the organizations boundaries at the micro level, working towards better international cooperation and collaboration. Thus, this research extends the concept of KM to include the process of managing knowledge in international organizations as defined below:

*Managing knowledge in international organizations is about harnessing the intellectual and social capital of its member countries, and the international knowledge worker, in order to improve organizational learning, international cooperation and global governance by providing knowledge focused process perspective to achieving the organizations goals.*

### **4 Conclusions**

As international relations have evolved, following the break-up of the Soviet Union [Lambert, 1993, Magarinos, 2005], one of the primary purposes of international organizations is to serve their member countries—towards achieving the Millennium Development Goals (MDG) [UN, 2006] set out in United Nations Millennium Declaration (MD), adopted by world leaders. It is from this perspective of renewed multilateral cooperation, the basis for organizing and governing internationally, that becoming knowledge focused is apparent as a way forward. Therefore becoming knowledge focused in international organizations is about developing reflective practices for effectively harnessing the world's political, scientific, and technological knowledge in the 21<sup>st</sup> century, to attain the ideals of human dignity, freedom, democracy, peace and development for all through international organizations functions.

#### **Acknowledgements**

This research has been supported by the Center for International Knowledge Management, Vienna, Austria.

#### **References**

- [CCPOQ 2000], CCPOQ: "Knowledge Management and Information Technology"; [online], 17th Session of the Consultative Committee on Program and Operational Questions (CCPOQ), Available from: <http://www.unssc.org/web1/programmes/km/documents/crp-14.pdf> [Accessed 22 July 2006], (2000)
- [CEB 2005], CEB: "One United Nations-catalyst for progress and change"; [online], Chief Executive Board (United Nations), Available from: <http://unsystemceb.org/oneun/> [Accessed 21 November 2006], (2005)

- [Gallupe, B. 2001], Gallupe, B.: "Knowledge management systems: surveying the landscape"; *International Journal of management Reviews*, 3, 1 (2001), 61-77
- [Hazlitt, H. 1988], Hazlitt, H.: "Economics in One Lesson: The Shortest and Surest Way to Understand Basic Economics"; Three Rivers Press, New York (1988)
- [Jackson, R. 1969], Jackson, R.: "A study of the capacity of the United Nations development system"; [online], Available from: <http://www.laetusinpraesens.org/docs/infwill/inf2.php> [Accessed 16 August 2007], (1969)
- [Lambert, Y. 1993], Lambert, Y.: "The United Nations Industrial Development Organization : UNIDO and problems of international economic cooperation"; Greenwood Publishing Group, Inc., Westport, CT (1993)
- [Magarinos, C. 2005], Magarinos, C.: "Economic development and UN reform"; United Nations Industrial Development Organization (UNIDO), Vienna, Austria (2005)
- [Perkmann, M., Scarbrough, H., Kannenkeril, R. and McCrea, J. 2005], Perkmann, M., Scarbrough, H., Kannenkeril, R. and McCrea, J.: "Knowledge Management in the Public Sector: A Guide to Good Practice"; British Standards Institution (2005),
- [Stewart, T. A. 1998], Stewart, T. A.: "Intellectual Capital: The New Wealth of Organizations"; Currency, New York (1998)
- [Strauss, A. and Corbin, J. 1990], Strauss, A. and Corbin, J.: "Basics of Qualitative Research"; Sage Publications, Newbury Park, California (1990)
- [Strauss, A. and Corbin, J. 1994], Strauss, A. and Corbin, J.: "Grounded theory methodology: An overview. " IN Denzin, N. and Lincoln, Y. (Eds.) *Handbook of Qualitative Research*. Thousand Oaks CA, Sage.(1994)
- [Ugbor, U. and Chanduvi-Suarez, C. 2007], Ugbor, U. and Chanduvi-Suarez, C.: "Becoming knowledge Focused: Developing a practice for managing knowledge in international organizations"; Proceedings of the 7th International Conference on Knowledge Management (IKnow 07), *Journal of Universal Computer Science* (2007),
- [UN 1945], UN: "Charter of the United Nations"; [online], United Nations, Available from: <http://www.un.org/aboutun/charter/> [Accessed 26 July 2006], (1945)
- [UN 2000], UN: "Millennium Development Goals"; [online], United Nations, Available from: <http://www.un.org/millenniumgoals/> [Accessed 18 January 2007], (2000)
- [UN 2005], UN: "History of the UN charter: The declaration of St. James Palace"; [online], United Nations, Available from: <http://www.un.org/aboutun/charter/history/> [Accessed 7 July 2007], (2005)
- [UN 2006], UN: "The Millennium Development Goals Report"; [online], United Nations, Available from: <http://mdgs.un.org/unsd/mdg/Resources/Static/Products/Progress2006/MDGReport2006.pdf> [Accessed 27 November 2006], (2006)
- [UNFCCC 2007], UNFCCC: "Parties to the Kyoto Protocol"; [online], United Nations Framework Convention on Climate Change, Available from: <http://maindb.unfccc.int/public/country.pl?group=kyoto> [Accessed 24 July 2007], (2007)

## **Expertise Finding for an Electronic Journal**

**Muhammad Tanvir Afzal, Narayanan Kulathuramaiyer, Hermann Maurer**

(Institute for Information Systems and Computer Media  
Graz University of Technology, Graz, Austria  
{mafzal, nara, hmaurer}@iicm.edu)

**Abstract:** Finding expertise is an important task required in all organisations and institutions. In looking for expertise, one typically relies on the compilation of information from multiple sources such as organisational directories and social networks. This approach has been applied to enhance the Journal of Universal Computer Science to enable it to become a still more valuable scholarly resource. This paper describes a multi-faceted representation of expertise, by consolidating human specified expert profile with systemic assessment of expertise. The multi-faceted approach is an important in the consolidation of information from multiple sources, in an effort to expand on the characterisation of expertise. The strength of this approach is drawn from the incorporation of intangible metrics for expertise assessment. This paper has revealed interesting directions for the automatic discovery of expertise in scholarly communities.

**Keywords:** multi-faceted expert profile, expertise matrices, digital journal

**Categories:** H.3.1, H.3.2, H.3.3, H.3.7

### **1 Introduction**

The discovery of expertise is crucial in supporting a number of tasks. A variety of tools have been implemented within organisations to find experts and expertise for different scenarios. Most related works make use of explicitly specified expert profiles constructed manually. The problem with such manually constructed profiles is that they tend to be developed for particular projects and constantly need to be updated e.g. [Pipek et al 2002].

Using an entirely automated mechanism for determining user expertise may also not be adequate in itself. As an illustration, Google Scholar employing an automated approach had wrongly identified names of places such as Ann Arbour, or Milton Keynes as cited authors [Postellon 2008]. This also highlights the non-trivial nature of expertise mining and the difficulty faced in the disambiguation of individuals.

There are also expertise detection systems that were based entirely on an analysis of user activity and behaviour while being engaged in an electronic environment. [Krulwich and Burkey 1995] have analyzed the number of interactions of an individual within a discussion forum as a means of constructing an expert's profile. Although such an approach is useful in monitoring user participation, measures such as number of interactions on a particular topic is in itself not reflective of knowledge levels of individuals.

This paper explores the discovery of expertise within the context of a digital electronic journal, the Journal of Universal Computer Science. J.UCS to date has more than 1,200 peer-reviewed articles covering all topics of Computer Science.

Articles published in J.UCS are classified and organized according to ACM categories.

## 2 Related Works

Expertise finder systems in the past, have been innovatively applied in helping PhD applicants in finding relevant supervisors [Liu and Dew 2004] and also in identifying peer-reviewers for a conference [Rodriguez and Bollen 2005]. The former made use of a manually constructed expertise profile database while the latter employed reference mining for all papers submitted to a conference. In the latter, a co-authorship network was constructed for each submitted paper making use of a measure of conflict-of-interest to ensure that papers were not reviewed by associates.

[Cameron et al 2007] employed a manually crafted taxonomy of 100 topics in DBLP covering the research areas of a small sample of researchers appearing in DBLP. They proposed the need for an automatic taxonomy creation as a key issue in finding experts. [Mockus and Herbsleb 2002] employed data from a software project's change management records to locate people with desired expertise in a large organization. Their work has presented a need to explicitly represent experiential characterization of individuals as a means of providing insights into the knowledge and skills of individuals. [Yimam and Kobsa 2003] have further shown that a decentralized approach can be applied for information gathering in the construction of expertise profiles. [Tho et al 2007] employed a citation mining retrieval technique where a cross mapping between author clusters and topic clusters was applied to assign areas of expertise to serve as an additional layer of search results organization.

## 3 A Multi-faceted Expert Profile

We propose the incorporation of multiple facets in providing a more representative assessment of expertise. We see these facets as providing multiple sources of evidence for a more reflective perspective of experts. In this paper, we present the combination of both tangible and intangible metrics to shed deeper insights into the intensity of expertise. The measures provided are, however, not absolute indicators of expertise as the discoveries are limited by the coverage of database of publications and expert profiles used.

In exploring a comprehensive characterization of expertise, we propose the following measurements: number of publications, number of citations received, extent and proportion of citations within particular area, expert profile records and experience. We have thus incorporated the use of user-defined profiles, "experience atom" (as proposed by [Mockus and Herbsleb 2002] to indicate fundamental experiential units), reference mining results, and a characterization of expert participation as facets of an expert profile. Combining all these factors provides a better indication of expertise with regards to a particular topic. Figure 1 shows the consolidated view of expert profile construction as applied in our research.



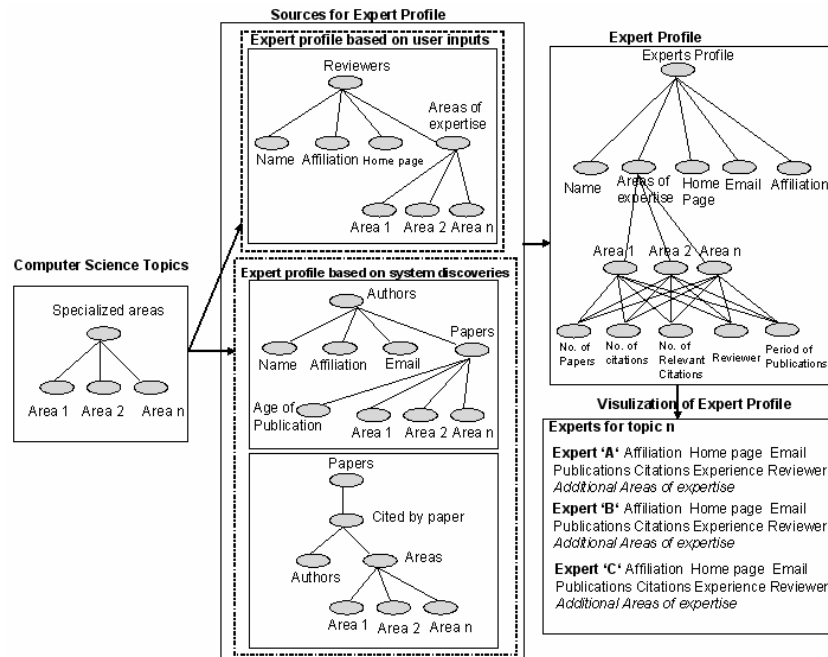

Figure 1: Building expert profile from numerous sources

In our research, there are two main sources of information used to construct an expert profile 1) user inputs and 2) system discoveries. User inputs are taken from reviewers of J.UCS. J.UCS has over than 300 reviewers on its editorial board. The expertise of these reviewers are specified and maintained according to the ACM categorization. We have extracted this information from J.UCS and have populated our expertise profile database.

The second source for constructing expert profile is computed by the system. The computation considers the number of publications of an individual, number of citations a person receives and person's age of publication in the respective area. The extraction of all publications (over 1,200) along with authors and co-authors of the publication is described in [Afzal et al 2007] with an extraction of over 15,000 citations [Afzal 2008].

We have developed a prototype system to extract expertise automatically and the preliminary results are shown in Figure 2. The results have demonstrated the importance of consolidating information from multiple sources in the construction of a detailed profile of experts.

## 4 Conclusion

We have presented a model of multi-faceted expertise characterisation, which takes into consideration both user-defined profile specification of as well as system-discovered features to augment and add value to an expert profile. Our preliminary

experiments have shown that this capability is extremely valuable for expertise finding within a digital journal.

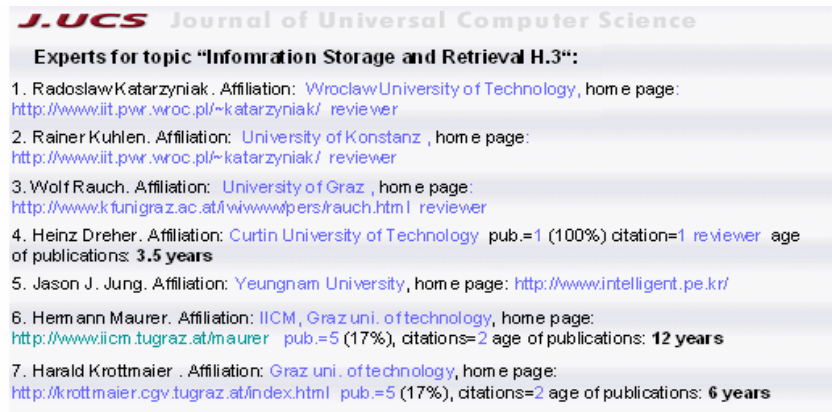

Figure 2: Discovered experts for topic "Information Storage and Retrieval"

## References

- [Afzal et al 2007] Afzal, M.T., Kulathuramaiyer, N., Maurer, H.: "Creating Links into the Future", J.UCS (Journal of Universal Computer Science), vol. 13, issue 9 (2007), 1234-1245.
- [Afzal 2008] Afzal, M.T.: "Citation Mining Technique for Creating Links into the Future", submitted to International Journal on Digital Libraries.
- [Cameron et al 2007] Cameron, D., Aleman-Meza, B., Arpinar, I.B.: "Collecting Expertise of Researchers for Finding Relevant Experts in a Peer-Review Settings", in 1st International ExpertFinder Workshop, 2007 Berlin, January 16, 2007
- [Krulwich and Burkey 1995] Krulwich, B., Burkey, C.: "ContactFinder: Extracting indications of expertise and answering questions with referrals". in the working Notes of the 1995 Fall Symposium on Intelligent Knowledge Navigation and retrieval. Technical Report FS-95-03, The AAAI Press, pp. 85 – 91.
- [Liu and Dew 2004] Liu, P., Dew, P.: "Using Semantic Web Technologies to improve expertise Matching within Academia", proceedings on I-Know, Graz, Austria, June 2004.
- [Mockus and Herbsleb 2002] Mockus, A., Herbsleb, J.D.: "A Quantitative Approach to Identifying Expertise", ICSE Orlando Florida, USA, May 2002.
- [Pipek et al 2002] Pipek, V., Hinrichs, J., Wulf, V.: "Sharing Expertise Challenges for Technical Support", in: Ackerman, M./Pipek, V./Wulf, V. (eds): Beyond Knowledge Management: Sharing Expertise, MIT-Press, Cambridge MA 2002 <http://www-winfo.uni-siegen.de/wulf/papers/downloads/paper03.pdf>
- [Postellon 2008] Postellon D.C.: "Hall and Keynes join Arbor in the citation indices", in Nature 452, 282. doi:10.1038/452282b.
- [Rodriguez and Bollen 2005] Rodriguez, M.A., Bollen, J.: "An Algorithm to Determine Peer-Reviewers" (submitted), ArXiv: cs/0605112v1 [cs.DL] 24 May 2006,

- [Yimam and Kobsa 2003] YIMAM-SEID D. KOBSA, A.: "Expert Finding Systems for Organizations: Domain Analysis and the DEMOIR Approach", in journal of organizational computing and electronic commerce 13 (1) 2003.
- [Tho et al 2007] Tho, Q.T., Hui, S.C., Fong, A.C.M.: "A citation based document retrieval system for finding research expertise", published in Information Processing and Management, 43 (2007) 248-264.

## **Query Log Analysis for User-Centric Multimedia Databases**

**Lyes Limam and Lionel Brunie**  
(LIRIS CNRS UMR 5205, INSA de Lyon  
Lyon, France  
{lyes.limam,lionel.brunie}@insa-lyon.fr)

**David Coquil and Harald Kosch**  
(Universität Passau, Passau, Germany  
{david.coquil, harald.kosch}@uni-passau.de)

**Abstract:** Recently, the information community has seen the emergence of user-centric media applications, which are characterized by the central position given to the user. To fulfill the user-centric promise, it is necessary to understand and model the actions of the users of the system. This position paper presents a methodology for modeling the behavior of multimedia database users. To this end, we propose to analyze the query logs to derive the classes of behaviors of a user. The presented method bases on the characteristics of user queries and on taxonomies. The behaviors are established using a query classification algorithm.

**Keywords:** user-centric, multimedia user behavior, multimedia database, taxonomy

**Categories:** H.2.8, H.3.3, H.5.1, H.5.2

### **1 Introduction and related work**

The user-centric approach is a design paradigm that is currently gaining momentum. It has been used as the guiding principle of a large number of systems in many domains, including information management [Smirnov 06], Community Information Management [Doan 07], information retrieval [Choi 06], etc. In user-centered systems, the user is the central entity. Her/his behavior must be fully understood so that it can be taken into account [Ha 06] to satisfy a number of purposes, e.g., to guide designers in design and management processes, to improve the quality of service or to personalize the usage of services.

Recently, a new type of user-centric applications has been proposed, called user-centric media systems, which focuses on applying the user-centric paradigm to multimedia systems. A report of the European Commission - DG Information Society and Media [European, 07] has defined user-centric media as being “about the user itself becoming the major media producer and distributor and about exploiting this media created by different citizens at different moments of time to generate a co-created application”. In this work the role of the users is limited to that of consumers or providers of multimedia content; their interactions with the system are neither modeled nor taken into account. In [Lachner 07], the authors present their view of the three major challenges of the user-centric media approach: comprehensive context awareness, personalized user interfaces, and multimedia content adaptation. Based on

this, they describe a set of requirements for the design of user-centric media applications. Here, the user behavior comprises only the actions or/and command performed on the system, and thus the users are not really integrated in the system.

In the multimedia information retrieval area, a growing number of works have adopted the user-centric point of view. For instance in [Choi 06], the authors propose a multidimensional browsing method of multimedia information for mobile devices in which the dimensions correspond to the user search criteria. This method facilitates the access to the query results and makes them easier to read. The authors argue that the traditional methods are not adapted to the small displays of mobile devices and to the large amount of retrieved information. This work could be improved if additional information about the user behavior were considered in order to personalize the presentation of query results.

In the above reviewed work, the user is considered as an external entity that interacts with the system via an interface. Nevertheless, there is no prior knowledge about the user behavior, the system responses only to the information provided in real time. There is previous work on methods for analyzing user behavior [Ha 06] but none of it specifically addresses user behavior in relation with multimedia content characteristics. In this position paper, we propose a method for modeling user behavior based on the analysis of multimedia query logs. The main idea is to construct classes of queries by discovering patterns which correspond to types of user behaviors. The proposed solution starts by defining the multimedia query, and the different query types; these query types are derived from MPQF, the future MPEG multimedia query language [Adistambha 07]. The search for patterns is based on comparing the characteristics of the individual queries which is performed using taxonomies that are built for each query type. The derived query classes correspond to the user behaviors, i.e. patterns.

## 2 Multimedia Query Logs

A query log is a file maintained by the server for each client that saves all the queries performed on the database, and optionally other contextual information (time, network parameters, etc.). Before we can use these files for our purposes, a set of pre-processing operations must be performed. For instance, doubles, invalid queries, empty queries, etc. are removed. Multimedia queries have specific properties compared to usual queries. Several categories of queries can be distinguished: Basic-features-similarity query, spatial-temporal query, free-text query, combination of query types. The main difference between queries of different categories is that they are expressed against different sets of characteristics. For example, in a spatial-temporal query the characteristics can be geographical positions, position related to other objects, distance, etc. in a basic feature similarity query the characteristics can be color (color space, color layout, etc), shape, texture, etc. or just a set of key words in the case of free text query. Therefore, it only makes sense to compare queries of the same category. Thus, the first task before starting to process the logs is to group the queries into subsets according to the categories.

### 3 User behavior

We consider the user behavior in a multimedia retrieval system as the way in which a user is interested in multimedia data. In order to capture this information, we analyze the query logs and try to find a semantic correlation between the queries expressed by a user. The part of the query that is considered is actually its specific characteristics as described in the previous section.

#### 3.1 Multimedia Taxonomy

In order to characterize user behavior, we use multimedia taxonomies. The goal is twofold, semantic and structural. The former is assured by the hierarchical relationships between the elements represented in the taxonomy, and the latter because it enables reasoning with graph concepts, (or more precisely trees). In our scheme, the taxonomy is constructed based on the content of the multimedia database, which represents the metadata instances (characteristics). Here we consider that the taxonomies are a priori constructed according to the query categories cited previously. They are: basic-features taxonomy, spatial-temporal taxonomy, free-text taxonomy. The last one deals with data which do not belong to any of the others.

#### 3.2 Queries classification

The comparison between two queries is done using the taxonomy. The requested characteristics expressed in the queries are matched with the taxonomy and the corresponding elements for each query form an internal structure in the taxonomy. The problem then comes down to deciding if two internal structures belong to the same class. To solve this problem, we first consider the taxonomy as a tree and an internal structure as a sub-tree, where nodes are the matched elements. The root of the sub-tree is the least upper bound node of an internal structure (the root can be either within the internal structure or a pre-selected element in the taxonomy). Then, we define a threshold  $T_s$  which corresponds to the maximum distance (number of edges) between two sub-tree roots of the same class.  $T_s$  is determined experimentally depending on the size of the taxonomy and the granularity. Hence, the problem of query classification consists to check whether there is a shortest path ( $P_{\min}$ ) between the two roots of two internal structures, such as the length of  $P_{\min}$  is less than or equal to  $T_s$ . A query is considered to be an element of a class if and only if the distance  $P_{\min}$  from each of the elements of the class is equal or less than  $T_s$ . The detail of the algorithm will be included nearly in a technical report.

#### 3.3 Interpretation and implication of user (group) behavior

The result of the previous step is a set of query classes, where each class corresponds to one behavior of the considered user. The interpretation of this result is facilitated by the hierarchical structure imposed by the taxonomy. In fact, by just locating the highest and lowest level elements of a class, we will be able to interpret the behavior. Moreover, the scheme described above may be generalized to deal with group of users: using the same principles, correlations between the behavior classes of two different users may be identified.

## 4 Conclusion

In this position paper, we have proposed a method for modeling user behavior in a multimedia database system by analysing the query logs. The proposed method considers the characteristics of the queries contained in the logs, in conjunction with taxonomies that represent the structure of the database and groups together the queries that share similar characteristics. After this query classification process, the resulting query classes are interpreted in order to derive user behaviors. The process is defined on a per user basis, but may be generalized to groups of users.

This work is a first step towards the goal of automating and integrating a tool to discover the behaviors of multimedia databases users. Such a tool would have many potential applications: automatic prediction of user needs, QoS improvement, selection of new content for enriching the database, etc. Thus, we plan to proceed with research in this direction. The first step will be to complete the multimedia taxonomies, to define a framework for each query type and to deal with queries of combined types. We will then evaluate the method using a real case study. On the longer run, we intend to generalise the concept of behavior by integrating other aspects such as contextual information in the user environment.

## References

- [Adistambha 07] Adistambha, K., Doeller, M., Tous, R. et al. , "The MPEG-7 query format: a new standard in progress for multimedia query by content,". ISCT '07, International Symposium on Communications and Information Technologies, vol., no., pp.479-484, 17-19 Oct. 2007
- [Choi 06] Choi, Y.-J., Yoo, S.J., Choi, S.-M. et al., "User-Centric Multimedia Information Visualization for Mobile Devices in the Ubiquitous Environment" international Conference on Knowledge-Based Intelligent Information and Engineering Systems (KES), Bournemouth October, 2006
- [Doan 07] Doan A., Bohannon P., Ramakrishnan R. et al., "User-Centric Research Challenges in Community Information Management Systems" IEEE Data Engineering Bulletin, special issue on data management in social networks. 2007
- [European, 07] European Commission-Networked Media Unit of the DG Information Society and Media: "User-centric Media Future and Challenges in European Research", Office for Official Publications of the European Communities, Luxembourg, 2007 — 76 pp.
- [Ha 06] Ha S., Jung H., and Oh Y. "Method to analyze user behavior in home environment". Personal Ubiquitous Comput. 10, 2-3 (Jan. 2006), 110-121.
- [Lachner 07] Lachner, J., Lorenz, A., Reiterer, B. et al., "Challenges Toward User-Centric Multimedia," smap, pp. 159-164, Second International Workshop on Semantic Media Adaptation and Personalization (SMAP 2007), London, 2007
- [Smirnov 06] Smirnov, A., Levashova, T., et al, "User-Centric Information Management for Decision Support in Disaster Relief & Evacuation," Military Communications Conference, 2006. MILCOM 2006 , vol., no., pp.1-7, 23-25 Oct. 2006

# **Social Software Strategies for Educational Technology Thematic Portals**

**Ramón Ovelar**

(Basque Country University, Spain  
ramon.ovelar@ehu.es)

**Manuel Benito**

(Basque Country University, Spain  
manuel.benito@ehu.es)

**Abstract:** Thematic portals are sites where subject matter experts select and organize information and, consequently, they can be described as top-bottom structures. While challenging this schema, implementing social information retrieval systems and social network representation features can improve user experience and the dissemination impact of the portal. We analyse the characteristics of social software and review examples of utilisation of these technologies that can be applied in an educational technology thematic portal.

**Keywords:** social media, read-write web, e-learning dissemination, thematic portals

**Categories:** H.3.3, H.3.5, H.5.1

## **1 Introduction**

A Web portal is a “gateway to an integrated collection of electronic resources providing a range of complementary services such as internal search, personalization, communication tools, push-technology information services and other specific services associated to the typology of portal” [Martínez, Palacios, 2004]. Manouselis and Sampson [Manouselis, Sampson, 2004] propose a flexible evaluation framework for Web portals that include the content, “their content (in terms of contained information or access to external information resources), their design (in terms of providing users a with a pleasant, usable and stable environment), their personalization capabilities (in terms of serving users’ specific preferences and needs), and their support to the formulation of virtual communities of users (in terms of bringing together users with similar interest and needs)”. Opposite to horizontal web portals, thematic portals have a domain-focus and represent a gateway to the information in the Internet of a particular area of knowledge.

From bulletin boards systems to groupware, forums, and email, computer mediated communication allowed the emergence of online communities involved in discussing and sharing [Reinghold, 1992]. Portals have included very frequently communication and collaboration tools. Nevertheless, before the generation of tools called social software, collaboration was practically pushed into the backgrounds of isolated silos such as mail lists and groupware and, therefore, the weight of Internet user participation was less significant. We claim that thematic portals, widespread



used in institutional policies for the promotion and dissemination of best practices, innovation and R&D, can benefit from social software strategies.

## 2 Characteristics of social software

Danah Boyd [boyd, 2007] attributes to Clay Shirky the first utilization of this expression –social software- to design “all uses of software that supported group interaction”. As the author explains, the choice of this new term was arguable, as other applications were formerly defined as groupware or social computing, and intended to emphasize the features of a new generation of software. However, beyond the marketing buzz there was a deeper transformation: “It’s about recognizing that the era of e-commerce centered business models is over; we’ve moved on to web software that is all about letting people interact with people and data in a fluid way” [boyd, 2007]. This new generation of tools has significantly lowered the barrier to users participating and creating content on the Internet. Social media sites, a sub-group of social software, allow users to contribute, annotate and evaluate content and also to create social networks where other users will appear as *friends* or *contacts* [Lerman, 2007]. While the main feature provided by pure social networks sites like Facebook is to articulate and make visible their professional and/or personal relationships, social media sites are fundamentally user-created content publication platforms where users can contribute but also filter and manage the submissions using social information retrieval features.

User-created content are resources available over the Internet, which reflect a certain amount of creative effort and are created outside of professional routines and practices [Vickery, Wunsch-Vincent, 2008]. From the perspective of a thematic portal, user-created content is an opportunity to foster the formation of an online community and to benefit from the strength of “the many”. From the sum of user interactions on the web, a collective intelligence able to highlight trends and patterns may emerge. Kolbitsh and Maurer [Kolbitsch, Maurer, 2006], using the parallelism of ant colonies -which are able to improve their knowledge of their environment and their organization by learning from individual decisions-, indicate that a critical mass of users participating in a collaborative system can produce the emergence of a community where the knowledge “is larger than the sum of knowledge and experience of all individuals”.

Nevertheless, community based systems cannot ensure the accuracy and quality of content the same way as editorial system do. There are not protocols assuring that information sources are checked or duly cited. Technical quality standards are either reviewed. “User-created content gatekeepers” are formed by three elements: the interest of the author in gaining a reputation, the collaborative filtering by the community and readers’ skills to differentiate between correct and incorrect information.

### 2.1 Social information retrieval

Social information retrieval systems differ from other information retrieval systems because they incorporate “information about social networks and relationships into the information retrieval process” [Kirsch, Gnasa, Cremers, 2006]. These systems

help users in the task of obtaining the information they need, harnessing previous choices by other users. Sometimes these systems are based on explicit actions, like tagging or rating, and in other cases they are based on the behaviour of other users.

Collaborative filtering systems work on the basis that we can take advantage of what others have discovered before and of their opinions regarding these resources [Malz, Ehrlich, 1995]. Some systems use an implicit collection mechanism, based on tracking the actions of the users: learning materials at Connexions<sup>1</sup> site include in their description a popularity index established with an implicit data collection mechanism. Other sites like OER Commons<sup>2</sup> demand explicit user descriptions through actions like tagging or rating.

Recommender systems are more sophisticated technologies that take into account specific user and/or content information in order to return personalized advice. These systems are used successfully in e-commerce sites like Amazon<sup>3</sup> or social music platforms like Last.fm<sup>4</sup>. However, implementation of such technologies in a portal can be challenging because a critical mass of users and/or resources is needed in order to obtain valuable outcomes.

## 2.2 Discussion, contribution and networking

Portals can provide tools such as personal blogs, forums or boards to enable user participation. A successful example of this approach can be seen at WarwickBlogs<sup>5</sup>, a social network site belonging to the University of Warwick<sup>6</sup>. All members of the university can have a personal blog along with other features. Another strategy rely on social aggregation features. Portals become hubs of the content generated by users in other platforms. Aulablog<sup>7</sup> is a Spanish educational technology portal has included a planet –software that aggregates the feeds of external blogs- in a section called Planeta Educativo. Bloggers continue to own their primary identity node but at the same time are rewarded by participating in a bigger conversation, entering a community and gaining visibility. Another model of contribution and networking is represented by Docencia.es<sup>8</sup>, a version of Digg<sup>9</sup> devoted to educational topics.

## 4 Conclusions

Thematic portals filter and organize information relevant to their domain-specific focus. Traditionally, this task has been carried out by editors and subject matter experts. Bottom-top strategies enabling users to contribute, evaluate and annotate content can help thematic portals. Nevertheless, quality and accuracy of content may

---

<sup>1</sup> Connexions <http://cnx.org/>

<sup>2</sup> OER Commons <http://www.oercommons.org/>

<sup>3</sup> Amazon <http://www.amazon.com/>

<sup>4</sup> Last.fm <http://www.last.fm>

<sup>5</sup> Warwick Blogs <http://blogs.warwick.ac.uk/showall>

<sup>6</sup> University of Warwick <http://www2.warwick.ac.uk/>

<sup>7</sup> Aulablog <http://aulablog.com/>

<sup>8</sup> Docencia.es <http://docencia.es/>

<sup>9</sup> Digg <http://digg.com>

be qualified as non-authoritative. Portals editors may need to articulate moderation systems or intermediate contribution models.

Future research to continue this analysis would study, through case studies, to what extent an editorial structure such as a portal can integrate a community-based organization. We would also revise the development of data interoperability technologies and standards for better integration of user activities within other tools in the portal. Finally, these conclusions should be applied to the specific context of users interested in e-learning.

## References

- [boyd, 2007] boyd, d.: The significance of social software, In T. N. Burg & J. Schmidt (Eds), *BlogTalks reloaded: Social software research & cases* (pp. 15-30). Norderstedt, Germany: Books on Demand 2007
- [Kirsch, Gnasa, Cremers, 2006] Kirsch, S., Gnasa, M., Cremers, A.: Beyond the Web: Retrieval in Social Information Spaces, In *Proceedings of the 28th European Conference on Information Retrieval (ECIR 2006)*, London, Springer (2006)
- [Kolbitsch, Maurer, 2006] Kolbitsch, J., Maurer, H.: The Transformation of the Web: How Emerging Communities Shape the Information we Consume *Journal of Universal Computer Science*, Vol. 12, No. 2, 187-213 2006
- [Lerman, 2007] Lerman, K.: Social browsing & information filtering in social media, Oct 2007. Available: <http://arxiv.org/abs/0710.5697>
- [Malz, Ehrlich, 1995] Malz, D. and Ehrlich, K.: Pointing the way: Active collaborative filtering. In the *Proceedings of CHI 1995*.
- [Manouselis, Sampson, 2004] Manouselis, N. and Sampson, D.: A Flexible Evaluation Framework for Web Portals Based on Multi-Criteria Analysis” In Tatnall, A. *Web Portals: The New Gateways to Internet Information and Services*. IGI Publishing 2004
- [Martínez, Palacios, 2004] Martínez, J.A, Palacios, E.: Los portales científicos como una herramienta para el fomento de la administración electrónica : contenidos y usuarios focalizados. E-LIS. 2004 Available at <http://eprints.rclis.org/archive/00006928/>
- [Reinghold, 1992] Reinghold, H.: A Slice of Life in My Virtual Community, Sausalito - Whole Earth Review 1992
- [Vickery, Wunsch-Vincent, 2008] Vickery, G., Wunsch-Vincent, S.: Participative Web and User-Created Content: Web 2.0, Wikis and Social Networking. October 2007 Available at [http://www.oecd.org/document/40/0,3343,fr\\_2649\\_201185\\_39428648\\_1\\_1\\_1\\_1,00.html](http://www.oecd.org/document/40/0,3343,fr_2649_201185_39428648_1_1_1_1,00.html)

# **Strategy Maps – A Tool for Strategic Management with High Impact on Organisational Knowledge Creation and Integration**

## **Unforeseen Experiences from a Balanced Scorecard Project in the Healthcare Sector**

**Klaus Valentin**

(Ramsauer & Stürmer Consulting, Linz, Austria  
valentin@rs-consulting.com)

**Martina Augl**

(Ramsauer & Stürmer Consulting, Linz, Austria  
augl@rs-consulting.com)

**Abstract:** In the context of the Balanced Scorecard development in the Upper Austrian Gesundheits- und Spitals AG (gespag) the methodology of strategy maps was applied in order to build a base for the definition of relevant areas of strategic measures. When applying the methodology it turned out that it is very supportive also from the knowledge management perspective (especially 2<sup>nd</sup> Generation KM), e.g. for the explication of knowledge, cognitive mapping, the creation of a common-mindset (organisational learning), the storage of information and individual learning about strategy and systemic thinking. Furthermore, it allows organisational knowledge integration meaning that people can integrate both the explicated knowledge in their system or their work, and the appropriate “sense” of the further information provided. The intention of the article is to show that methods of strategic management, and possibly from many other fields, can also be very beneficial in a knowledge management context.

**Key Words:** Knowledge Management, knowledge creation, knowledge integration, strategy maps, balanced scorecard

**Categories:** M.1, M.4

## **1 Introduction**

In February 2007 the Balanced Scorecard (BSC) project in the “Oberösterreichischen Gesundheits- und Spitals AG” (gespag) was started. The aim of the project was to develop and implement a BSC in various organisational entities in order to increase the effectiveness and efficiency of the operationalisation and implementation of organisational strategies. The gespag was founded in 2001 and consists of the headquarter, 10 hospitals, schools and academies for the education in the field of health professions, and the inhouse department health informatics. Currently the gespag employs about 9.000 persons.

The project started with an investigation of existing strategy related documents, followed by a development of strategy maps in order to translate organisational

strategies into areas of organisational change (strategy oriented objectives) that are relevant for the achievement of the defined targets. In order to integrate all relevant stakeholders, background knowledge, and insights a project team with representatives from the operational management, the gespag hospitals, and schools and academics was set up.

## **2 The Methodology of Strategy Maps and their Application in the gespag BSC Project**

The elaboration of a strategy map builds one important step when developing a BSC. It is performed after the analysis of strategic documents and assumptions. Prerequisite for the development of a strategy map is the existence of a defined and agreed organisational strategy. A strategy map builds a visual reference for an organisation with regards to its strategic objectives [Kaplan, 2004].

The aspects covered in a strategy map are:

- 1) Relevant steering perspectives
- 2) Strategy oriented objectives – areas for organisational development
- 3) Cause-and-effect chains between objectives

Steering perspectives were derived from the question about the central influencing factors for the achievement of strategic objectives. The perspectives should cover both, the main internal and external aspects like customers or investors (external) and internal aspects like processes, finance and learning. In respect of the gespag, the four perspectives are official mandate/customers and patients, financial aspects, service provision, and employees/internal potentials. Based on the main strategy, areas of change have been defined for each perspective in form of concrete objectives.

As a third step cause-and-effect chains were identified by investigating and documenting the altering dependencies between objectives. As it turned out that the views and possibilities of interrelations can be almost unlimited (interesting from a knowledge management perspective when it comes to the explication of individual knowledge in the discussions), the question with regards to the interrelation was concretised towards a focus on critical influence on strategic objectives. Furthermore, it was decided to represent only relations from the bottom to the top perspective (see figure 1) in order to build “stories of change” that should be communicated to the employees for a better understanding of the strategy.

The advantage of strategy maps is that all relevant information about the strategic objectives of an organisation can be presented at “one glance”. It is a good support for the communication of strategic objectives and interrelations.

Pictures build a very important medium for communication. Nevertheless objectives and interrelations were documented verbally to avoid multiple interpretations of the single terms and lines.

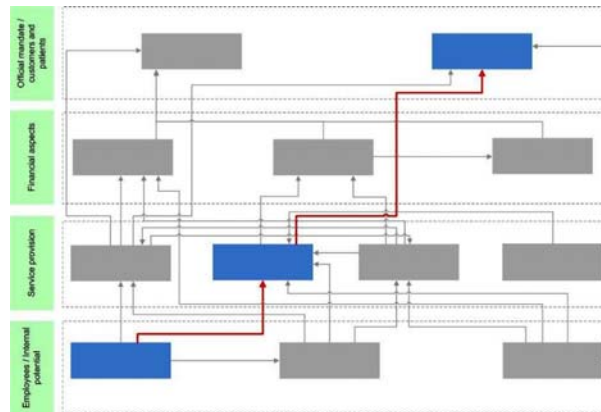

Figure 1: The overall strategy map of the gespag incl. “stories of change” (red lines)

### 3 The Methodology of Strategy Maps from the Perspective of Knowledge Management

As became clear in the last chapters the process of developing a strategy map needs intensive discussions. The discussion of an organisation’s strategies from various perspectives and their interrelations is much about exploring overall and one’s own mental models, attitudes, and values. In this context, emotions can arise easily. Therefore, it is necessary to be able to suspend one’s own point of view and get into some kind of dialogue with each other [Bohm, 1996]. Thus, individual concepts can be made explicit and individual knowledge claims [Mc Elroy, 2003] can be brought in.

Dialogue has a great impact on individual learning [Argyris, 1978] especially since the project team was composed of different key persons from all relevant areas of the organisation. Throughout the process the different knowledge claims were evaluated several times.

The concept mapping did a lot of helpful work in this intensive process: it made (partly implicit) knowledge and claims explicit and created pictures and better understanding in the minds of the team members; resulting in shared meaning and organisational learning [Kim, 2001].

Drawing the most important interrelationships (cause-and-effect chains) led to a better understanding of the organisation as a whole, its strategic intentions, and the contradictions between the various perspectives. Thus, the development of the map strongly supported the developing of expertise in systemic thinking, seeing the “big picture”, and sensing to complex interrelations. The development of shared meaning on the one hand and personal involvement and engagement within the process on the other hand led to strong commitment and motivation for the gespag BSC.

A strategy map can be seen as a kind of knowledge map that represents the strategy and objectives of the organisation and gives insight knowledge into the discussion process. The map is a beneficial tool for the communication of the strategy towards all employees and therefore also for organisational knowledge integration.

The process behind the development, reflexion, and communication of strategy maps supports the concept of 2<sup>nd</sup> Generation Knowledge Management [McElroy, 2003]. “Classical” (1<sup>st</sup> Generation) Knowledge Management assumes that all (relevant) knowledge is already existing and only has to be transferred from A to B and can then be used throughout the organisation (supply-side view). The 2<sup>nd</sup> Generation is adding the aspect of knowledge production and describes the whole knowledge life cycle as a recursive process of knowledge production, integration and use (demand-side view). The setting of the project in different teams (core team, project team, sub-teams) made it necessary to “run the knowledge life cycle” several times – ending in a lot of critical thinking, reflexion, and new ideas.

## 4 Conclusion

The paper at hand presented the experiences that were made by Ramsauer & Stürmer Consulting during the development process of the BSC in the gespag when elaborating the strategy map for the headquarter. These experiences show that strategy tools can also be seen as instruments of knowledge management when consciously used in this context. In many cases this consciousness does not exist in companies or public institutions. So when performing such strategic activities knowledge management issues can (and should) also be taken into account and communicated towards the clients. This will lead to new benefits in strategy related consulting projects.

## References

- [Argyris 1978] Argyris, C., Schön, D.: *Organizational Learning – A Theory of Action Perspective*, Addison Wesley Longman Publishing Co, Reading, Massachusetts, 1978
- [Augl, 2008] Augl, Martina: *Beyond Wor(l)ds: Modernes Wissensmanagement als Mittler zwischen Portalen und Unternehmenskultur*, Books on Demand, Norderstedt, 2008
- [Bohm, 1996] Bohm, D.: *On Dialogue*, Routledge, New York, 1996
- [Born, 2003] Born, R.: *Knowledge Integration: Its relation to organisational learning, to Knowledge Management (KM) Methods (e.g. BSC) and to measuring the benefits of KM*, unpublished paper, Linz, 2003
- [Kaplan, 1996] Kaplan, R., Norton, D.: *The Balanced Scorecard, translating strategy into action*, Harvard Business School Press, Boston, 1996
- [Kaplan, 2004] Kaplan, R., Norton, D.: *Strategy Maps, Der Weg von immateriellen Werten zum materiellen Erfolg*, Schäffer-Poeschel, Stuttgart, 2004
- [Kim, 2001] Kim, D.: *Organizing for learning: Strategies for Knowledge Duration and Enduring Change*, Pegasus Communications, Waltham, 2001
- [Mc Elroy, 2003] McElroy, M., Firestone, J.: *Key Issues in the New Knowledge Management*. Butterwoth Heinemann, Burlington, 2003
- [Senge, 2005] Senge, P.: *The Fifth Discipline*, Klett Cotta Verlag, Stuttgart, 2005

## **The TUGLL-Plug-ins**

### **Special Needs for a University Wide Blogosphere**

**Martin Ebner, Behnam Taraghi, Walther Nagler**  
(Dept. Social Learning, Computer and Information Services (CIS))  
Graz University of Technology, Austria  
martin.ebner@tugraz.at)

**Abstract:** This paper presents extensions that have been programmed by the Department Social Learning (DSL) at Graz University of Technology (TU Graz) for a blogosphere used at TU Graz called TU Graz LearnLand (TUGLL) on base of the open source software ELGG. These extensions are useful upgrades to the system following the demands of the pedagogical strategy of the TU Graz. A description of the extensions and didactical considerations are discussed.

**Keywords:** Higher Education, Weblog, Web 2.0, e-Learning

**Categories:** K 3.1, L 3.0, L 3.6

## **1 Introduction**

Web 2.0 applications [O'Reilly, 06] such as Wikipedia, YouTube, Flickr etc. are pervading our daily life more and more [Maurer, 06] [Richardson, 06] [Korica, 06] [Kolbitsch, 06]. In this context the importance of weblogs as a way to express individual thoughts and experiences is increasing enormously. Learning and teaching processes are influenced by these technologies as well. In case of Web 2.0 applications used for learning scenarios this is named E-Learning 2.0 [Downes, 05]. Although a lot of Web 2.0 technologies have their origins in the 90s of the last century actually the breakthrough of Web 2.0 has been facilitated by the establishment of broadband in the last few years. Researches, experiences and evaluations about the didactical reasonable usage in practice of Web 2.0 technologies such as weblogs for teaching purposes are therefore rare.

Since October 2006 TU Graz has decided to support a university wide blogosphere called TUGLL on base of the open source software ELGG. TUGLL offers an own personal blog environment for each member of the TU Graz, students as well as teachers and other employees. These blogs are connected to each other and display the community of TUGLL. A personal blog is being created by the first login of the new user. After half a year of experiences lots of necessities adjusted for teaching and learning behaviours were added. In other words the blogosphere had to be enhanced with "special needs". In this publication plug-ins targeting on these needs that had been programmed by the DSL are described. Another chapter attends to the aspect that these extensions base on pedagogical considerations.



## **2 The TU Graz LearnLand**

ELGG<sup>1</sup> is an open source blogosphere platform that is used as a social networking environment at TU Graz. By definition to be read at ELGG homepage "... it was established in March 2004 by Ben Werdmuller and David Tosh and designed to allow people to easily connect and share resources. Users can establish digital identities and connect with other users, collaborate with them and discover new resources through their connections. Plug-ins allow users on different social networks to collaborate, and provide specific functionality ...".

### **2.1 Extensions**

Expandability is an advantage of the system and bases on its modular structure. Plug-ins can easily be implemented and attached to the system to increase and expand the functionality without interfering with other modules. The following subchapters describe Plug-ins and extensions developed by the DSL focusing on learning purposes.

#### **2.1.1 The "Bookmarks Plug-in"**

The "bookmarks plug-in" in combination with ranking module [Ebner, 08b] enables users to share interesting links and URLs as additionally information., It can be compared to famous applications like "del.icio.us" and "Mr. Wong". To simplify saving bookmarks an import/export-functionality comes with the plug-in. Lists of bookmarks saved on local browsers, can easily be imported and shared with a single click. The plug-in also supports bookmark files as XBEL format (XML Bookmark Exchange Language). Another feature that makes bookmarking easier is the "TUGLL it" browser button, a so-called bookmarklet. Once installed the user only needs to click on the "TUGLL it" browser button and the current URL gets saved as a bookmark in the personal blog on TUGLL.

#### **2.1.2 The "XMLRPC Client Plug-in"**

As mentioned at the beginning, TUGLL bases on ELGG, which is an open source blogosphere platform that is meant to be used as a social networking environment by many universities and scientific organisations worldwide. The "XML-RPC Client plug-in" allows ELGG platforms to communicate and interact with each other. It provides their users with different services through a web service interface, which is based on XML-RPC, a remote procedure call protocol. If the search mechanism of the ELGG system is being expanded into the plug-in during installation it is even possible to let the search run through other ELGG platforms connected to.

#### **2.1.3 The "Module Settings Plug-in"**

The "module settings plug-in" helps the user to configure existing modules according to personal needs and preferences. The user may activate or deactivate single modules

---

<sup>1</sup> <http://elgg.org> (last visited: 08.04.2008)

and sidebar elements one by one or set their status by default. Modules and their corresponding sidebar elements can also be sorted or hidden.

#### **2.1.4 Generic Widgets for Profile-Page and Sidebar**

The user's profile is the page where the user presents her-/himself. In addition to usual personal information comprising contact data, interests, likes, dislikes, and so on, users can implement different types of widgets to their personal profile page and sidebar. The idea of this extension is to let the user design her/his own profile/sidebar generically. No definite types are defined; the user is able to embed any kind of widget into her/his personal profile page, which for instance could be a piece of HTML code, java script or flash application.

#### **2.1.5 MetaWeblog API**

The need to increase usability for simplifying interaction with the modules of the platform is obvious. The "TUGLL it" browser button is a good example for this task. Users can save bookmarks as easy and fast as possible even with no login to the system. The "MetaWeblog API" provides users the same functionality but for blogs. It enables the so-called remote blogging. The user only needs to install an offline blogging tool. After setting the access data and the "MetaBlog API"-URL the user can start blogging offline with no need to login to the system. Another advantage of the "MetaWeblog API" is the possibility to post a contribution on one platform and a copy of it is being saved on other platforms too, assumed that they support this API.

### **3 Plug-ins' relevance from a pedagogical point of view**

Discussing the fact that the implementation of a new tool for teaching and learning efforts must come along with didactical scenarios; otherwise the new tool will hardly be accepted by teachers and students and cannot be implemented or used in a reasonable way. There is no perfect teaching or learning tool inherently. First of all the user must feel comfortable about using the tool then he/she will become more creative by using it. Nevertheless each tool has specific aims and functions and insofar is limited to its usability per se [Ebner 08a].

#### **3.1 Discussing the TUGLL extensions**

The "bookmarks plug-in" meets the advantage of the community character of a blogosphere and furthermore fulfils the desire to collect things and have them available anywhere and anytime. The beneficial aspect is that bookmarks become part of a whole system of personal data, files and history within a community. The pedagogical effect is that anybody of this community gains from ones personal experiences. Therefore the "bookmarks plug-in" has been enlarged with a ranking system. Users are able to evaluate each other bookmarks and with the help of a ranking algorithm the most important bookmarks according to personal needs can be presented.

The "XMLRPC Client Plug-in" can be seen as a service for optimisation of the way we explore information. The possibility to search not only in one but many

ELGG databases increases the probability to hit the information searched for and enhance the local university community by connecting to other educational institutes.

The “Module Settings Plug-in” and the “Generic Widgets for profile-page and sidebar” satisfy the needs for individualisation as well as for usability. It is of high importance that the user has the opportunity to adapt a system to her/his individual demands. The more this is enabled the more she/he will identify with it and feel convenient to work, learn, teach, play and live with it.

Finally the “MetaWeblog API” specialises the remote blogging functionality of ELGG and matches it to fit in other blog-systems than ELGG if wanted.

## 4 Summary

Stephen Downs asked whether weblogs might become personal learning environments in the future [Downes, 07]? Since their integration to the e-Learning strategy of the TU Graz, TUGLL has become a multifunctional platform already exceeding the intentions of a blogosphere. It has turned into an online community-storage of personal collected information, interactions and individual connections displaying the historic of ones own study. The power of weblogs is beginning to transform into a kind of e-Portfolios more and more.

## References

- [Downes, 05] S. Downes, E-Learning 2.0, ACM eLearn Magazine, October 2005 (10)
- [Downes, 07] S. Downes, Trends and Impacts of E-Learning2.0, International Conference on Open Courseware and eLearning, Taiwan <http://www.slideshare.net/Downes/trends-and-impacts-of-elearning-20>
- [Ebner, 08a] M. Ebner, W. Nagler, Has the end of chalkboard come? A survey about the limits of Interactive Pen Displays in Higher Education, MICROLEARNING2008 conference, Innsbruck, in print
- [Ebner, 08b] M. Ebner, B. Taraghi, A Blog Sphere for Higher Education, ED-Media 2008, in print
- [Kolbitsch, 06] J. Kolbitsch, Kōrero: An Integrated, Community-Based Platform for Collaboration, 2006, in print, <http://www.kolbitsch.org/research/papers/2006-Korero.pdf> (last visited: March 2008)
- [Korica, 06] P. Korica, H. Maurer, W. Schinagl, The growing importance of e-Communities on the Web, International Conference on Web Based Communities (IADIS), p. 165-174
- [Maurer, 06] H. Maurer, W. Schinagl, Wikis and other e-Communities are changing the Web, Proceeding of ED-Media 2006, AACE, p. 2858-2866
- [O’Reilly, 06] T. O’Reilly, Web2.0: Stuck on a name or hooked on value?, 2006, Dr. Dobbs Journal, 31(7), 10-10
- [Richardson, 06] W. Richardson, Wikis, Podcasts and Other Powerful Web Tools for Classrooms, Corwin Press, Thousand Oaks (CA)



## Author Index

### A

A. Cerri, S., 92  
Afzal, M., 436  
Albert, D., 276, 288  
Augl, M., 449

### B

Bahrs, J., 378  
Benito, M., 445  
Bischof, H., 313  
Bjørn-Andersen, N., 185  
Blaise, J., 349  
Blanc, N., 92  
Bock, B., 210  
Boldakov, A., 430  
Born, R., 126  
Botvich, D., 405  
Bredl, K., 177  
Bresciani, S., 316  
Brunie, L., 441  
Brüggemann, S., 251

### C

Cao, Y., 169, 218  
Colucci, S., 259  
Conruyt, N., 194  
Coquil, D., 441  
Cucu, C., 142

### D

Di Sciascio, E., 259  
Doehring, M., 109  
Donini, F., 259  
Du, Y., 387  
Dudek, I., 349

### E

Ebner, M., 234, 453  
Eppler, M., 134  
Eppler, M., 316

Eriksson, H., 76  
Eschenbach, S., 68

### F

Faatz, A., 109  
Fiechter, C., 53  
Fundneider, T., 11

### G

Gindl, S., 243  
Glukhova, A., 169, 218  
Godehardt, E., 109  
Goertz, M., 109, 118  
Gordon, A., 296, 421  
Granitzer, M., 313  
Grebner, O., 387  
Grinev, M., 430  
Grineva, M., 430  
Grüning, F., 251

### H

Haas, W., 1  
Haasler, C., 161  
Hahne, A., 218  
Happel, H., 28  
Harrer, A., 304  
Hauer, I., 61  
Heath, T., 8  
Heim, P., 324  
Helbig, T., 202  
Hinkelmann, K., 369  
Hoffmann, A., 267  
Hotho, A., 403  
Huet, B., 202

### I

Ivanova, M., 84

### J

Judge, J., 405

**K**

Kappe, F., 1, 234  
Kemper, P., 6  
Kern, E., 53  
Khadka, C., 101  
Kienreich, W., 313  
Klamma, R., 161, 169, 218  
Koch, M., 53  
Kockler, M., 226  
Kohlhammer, J., 332  
Kosch, H., 441  
Kroeger, S., 413  
Kulathuramaiyer, N., 436

**L**

Leifler, O., 76  
Leutgeb, A., 395  
Ley, T., 276, 369  
Lieberman, H., 7  
Liebig, T., 341  
Limam, L., 441  
Lindstaedt, S., 276, 366, 369  
Lohmann, S., 37, 304  
Lokaiczny, R., 118  
Lukose, D., 9  
Lux, M., 403, 425

**M**

Maicher, L., 210  
Maier, R., 304, 366, 369  
Marques, O., 425  
Maurer, H., 1, 436  
Mayr, B., 126  
Mayr, E., 280  
Mommel, M., 226, 276  
Meuthrath, B., 378  
Meyer zu Eissen, S., 358  
Muntean, M., 61  
Müller, C., 413

**N**

Nagler, W., 453  
Niesenhaus, J., 37

Nissen, V., 19  
Noppens, O., 341  
Nussbaumer, A., 288

**O**

Ong, E., 387  
Ossimitz, G., 150  
Ovelar, R., 445

**P**

Pammer, V., 366  
Peschl, M., 11  
Peters, K., 378  
Petrushyna, Z., 169  
Pettersson, U., 45  
Pircher, R., 280  
Pitman, A., 425

**R**

Ras, E., 276  
Rasmussen, L., 185  
Rasmussen, S., 185  
Renzel, D., 218  
Richter, A., 53  
Risku, H., 280  
Riss, U., 369, 387  
Risteiu, M., 142  
Russ, C., 150

**S**

S. n . nunes, M., 92  
Sabol, V., 313  
Scharl, A., 243  
Schauer, B., 68  
Scheir, P., 366  
Schirru, R., 226  
Schmeil, A., 134  
Schmidmayr, P., 234  
Schmidt, A., 369  
Schorcht, H., 19  
Sebastien, O., 194  
Sizov, S., 403  
Sogrin, M., 405  
Stein, B., 358

Steiner, C., 288  
Stojanovic, L., 28  
Strohmaier, M., 403  
Swanson, R., 421

## **T**

Taraghi, B., 453  
Tekusova, T., 332  
Thalmann, S., 304  
Tochtermann, K., 1  
Troussov, A., 405  
Turdakov, D., 430  
Turlier, S., 202

## **U**

Ugbor, U., 432

## **V**

Vacik, H., 101  
Valentin, K., 449  
Velikhov, P., 430  
Voss, V., 332  
Vögel, H., 202

## **W**

Weber, N., 366  
Wechselbraun, A., 243  
Woitsch, R., 395

## **Z**

Zenk, L., 280  
Ziegler, J., 324