

Indriani, Gustya

Research Report

Gas flaring reduction in the Indonesian oil and gas sector: Technical and economic potential of Clean Development Mechanism (CDM) projects

HWWA-Report, No. 253

Provided in Cooperation with:

Hamburgisches Welt-Wirtschafts-Archiv (HWWA)

Suggested Citation: Indriani, Gustya (2005) : Gas flaring reduction in the Indonesian oil and gas sector: Technical and economic potential of Clean Development Mechanism (CDM) projects, HWWA-Report, No. 253, Hamburg Institute of International Economics (HWWA), Hamburg

This Version is available at:

<http://hdl.handle.net/10419/32895>

Standard-Nutzungsbedingungen:

Die Dokumente auf EconStor dürfen zu eigenen wissenschaftlichen Zwecken und zum Privatgebrauch gespeichert und kopiert werden.

Sie dürfen die Dokumente nicht für öffentliche oder kommerzielle Zwecke vervielfältigen, öffentlich ausstellen, öffentlich zugänglich machen, vertreiben oder anderweitig nutzen.

Sofern die Verfasser die Dokumente unter Open-Content-Lizenzen (insbesondere CC-Lizenzen) zur Verfügung gestellt haben sollten, gelten abweichend von diesen Nutzungsbedingungen die in der dort genannten Lizenz gewährten Nutzungsrechte.

Terms of use:

Documents in EconStor may be saved and copied for your personal and scholarly purposes.

You are not to copy documents for public or commercial purposes, to exhibit the documents publicly, to make them publicly available on the internet, or to distribute or otherwise use the documents in public.

If the documents have been made available under an Open Content Licence (especially Creative Commons Licences), you may exercise further usage rights as specified in the indicated licence.



REPORT

**Gas Flaring
Reduction in the
Indonesian Oil and
Gas Sector –
Technical and Economic
Potential of Clean Development
Mechanism (CDM) projects**

Gustya Indriani

HWWA-Report

253

Hamburgisches Welt-Wirtschafts-Archiv (HWWA)
Hamburg Institute of International Economics
2005

ISSN 0179-2253

The HWWA is a member of:

- Wissenschaftsgemeinschaft Gottfried Wilhelm Leibniz (WGL)
- Arbeitsgemeinschaft deutscher wirtschaftswissenschaftlicher Forschungsinstitute (ARGE)
- Association d'Instituts Européens de Conjoncture Economique (AIECE)

Gas Flaring Reduction in the Indonesian Oil and Gas Sector – Technical and Economic Potential of Clean Development Mechanism (CDM) Projects

Gustya Indriani

I thank Dr. Axel Michaelowa of the Programme International Climate Policy for research supervision. The CDM Capacity Building Programme of GTZ provided travel funding for data collection in Indonesia. The report was submitted as Masters Thesis under the International Master Program in Environmental Engineering at Technical University of Hamburg-Harburg under the supervision of Prof. Dr. rer. Nat. Ulrich Förstner and Prof. Dr.-Ing. Wilfried Schneider.

HWWA REPORT

Editorial Board:

Prof. Dr. Thomas Straubhaar

Dr. Klaus Kwasniewski

Dr. Konrad Lammers

Dr. Eckhardt Wohlers

Hamburgisches Welt-Wirtschafts-Archiv (HWWA)

Hamburg Institute of International Economics

Öffentlichkeitsarbeit

Neuer Jungfernstieg 21

20347 Hamburg

Phone: +49-040-428 34 355

Fax: +49-040-428 34 451

e-mail: hwwa@hwwa.de

Internet: <http://www.hwwa.de/>

Gustya Indriani

Gang Repeh-rapih no 28,

Muararajeun Beun

Bandung 40122, Indonesia

Phone: +62 22 7207507

e-mail: gustya.indriani@nithh.de

Abstract

Indonesia currently ranks as the world's 17th oil and 6th gas producer, but its production levels are slowly declining. In Indonesia, the oil companies may extract, process and market associated gas jointly with the State Oil and Gas Board. In addition, they are allowed to use associated gas in operations, as well as re-inject or flare gas that cannot be marketed. However, associated gas is still considered as a by-product of oil, which can disturb the oil flow. Due to the lack of markets, institutions and regulations, the associated gas is often simply flared instead of being used. Flaring currently amounts to about 5% of gas production and generates 10 million t CO₂. On the company level, gas flaring data show that 80% of total GHG emission from flaring was released by ten companies. By using the Clean Development Mechanism (CDM) to reduce gas flaring, the economic use of gas will be maximised. Other options are gas re-injection, gas to pipeline, improvement of flare efficiency, Natural Gas Liquids recovery, GTL and fuel switch. Large scale projects in gas flaring reduction are more feasible, especially for remote oil fields. But some cases show that small scale projects in small fields with local market opportunity are feasible as well.

Contents

1	Introduction	5
	1.1 Anthropogenic Climate Change	6
	1.2 The Kyoto Protocol	7
	1.3 Clean Development Mechanism (CDM)	9
	1.4 Sustainability	12
	1.5 Oil and Gas	12
	1.6 Indonesian Overview	14
	1.7 Gas flaring	17
	1.8 Purpose and Outline of the Report	19
2	Methods to Assess CDM in Gas Flaring Reduction	20
	2.1 Sustainable Development	20
	2.2 Reduction of GHG Emission – Additionality and Baseline	22
	2.3 Institutional Risk and Uncertainties	29
	2.4 Carbon Market Development	30
	2.5 Current CDM Activities in GFR in Indonesia	33
3	Data Collecting and Calculations	35
	3.1 General	35
	3.2 Data on Oil, Gas and Gas Flaring	39
	3.3 Data on Greenhouse Gas Emissions	40
	3.4 Calculation of gas-to-oil ratio (GOR)	44
4	Oil, Gas and Gas Flaring in Indonesia	46
	4.1 Oil Production	47
	4.2 Gas Production	51
	4.3 Gas Flaring	53
5	Greenhouse Gas Emissions and Gas-to-oil Ratio	58
	5.1 GHG Emissions from Gas Flaring in Indonesia	58
	5.2 Calculation of Gas-to-Oil Ratio (GOR)	67
6	Assessment of Gas Flaring Reduction as a CDM Project	69
	6.1 Technical Potential	69
	6.2 Economic Potential	82
	6.3 CDM Projects in Gas Flaring Reduction in Indonesia	92
7	Facilitation of Gas Flaring Reduction Projects in Indonesia	100
8	Summary	102
	Appendix	105
	References	129

1 Introduction

Climate change is a global phenomenon that affects all parts of the world. As an archipelago located on the equator, Indonesia will suffer some impacts from anthropogenic climate change. A study done by the Union of Concerned Scientists (UCS) predicted that Indonesia will experience impacts of global warming in the form of, for example, drought and fires. Wildfires 1998 and onwards burned up a huge area of rainforests, including the habitat of some endangered species. In addition, the climate change affects the coral reef bleaching in the Indian Ocean as well as the spread of malaria in high elevations, i.e. the highlands of Irian Jaya.

The Kyoto Protocol does not specify greenhouse gas reduction targets for Indonesia and other developing countries, but instead gives them opportunities to generate inflows of technology and capital through the Clean Development Mechanism (CDM). The CDM generates emission credits through projects in various sectors to reduce greenhouse gas emissions. Indonesia, as a large oil producer, might consider reducing the gas flaring process, which is linked to oil production, as a CDM project option.

This study discusses the technical and economical aspects of gas flaring reduction projects in Indonesia. The introduction will present an overview of this issue, including the basic process of climate change, characteristics of the Kyoto Protocol and current conditions in Indonesia. The purpose and structure of the report is explained at the end of this chapter.

1.1 Anthropogenic Climate Change

As radiation from the sun enters the earth's atmosphere, most of it is radiated back into the sky in the form of thermal radiation (Houghton, 2004). However, some gases known as greenhouse gases (GHG), such as CO₂, CH₄, N₂O and certain industrial gases act like glass in a greenhouse: they allow ultra violet and visible radiation to pass but absorb infrared energy. This phenomenon is called the greenhouse effect. Actually, this natural greenhouse effect is necessary in order to have an inhabitable earth. Without it, the earth would be 34⁰C colder than the current temperature (Murdiyarso, 2003c).

Human activities since the Industrial Revolution have led to an increase of GHG concentrations in the atmosphere and have thus enhanced the greenhouse effect. Already in the 20th century, global surface temperature increased by 0.6⁰C and in the period from 1990 to 2100, the earth's surface temperature is anticipated to rise by 1.4 to 5.8⁰C (Houghton et al, 2001). This warming is expected to melt the North Pole's ice and mountain glaciers, leading to a rise in the sea level of 15 to 95 cm. Further impacts are expected, such as a longer dry season and a shorter rainy season, more extreme precipitation, floods, droughts and forests fires.

Currently the GHG emission per capita of developed countries is far above the one of developing countries. However, the climate change is a global problem. Its impact will affect all regions in the world, and then all countries will have to make efforts to lessen the climate change. If the non-developed countries do not try to reduce their GHG emission, it is projected that in the year 2020 their emission will exceed that of the developed countries' (Figure 1.1).

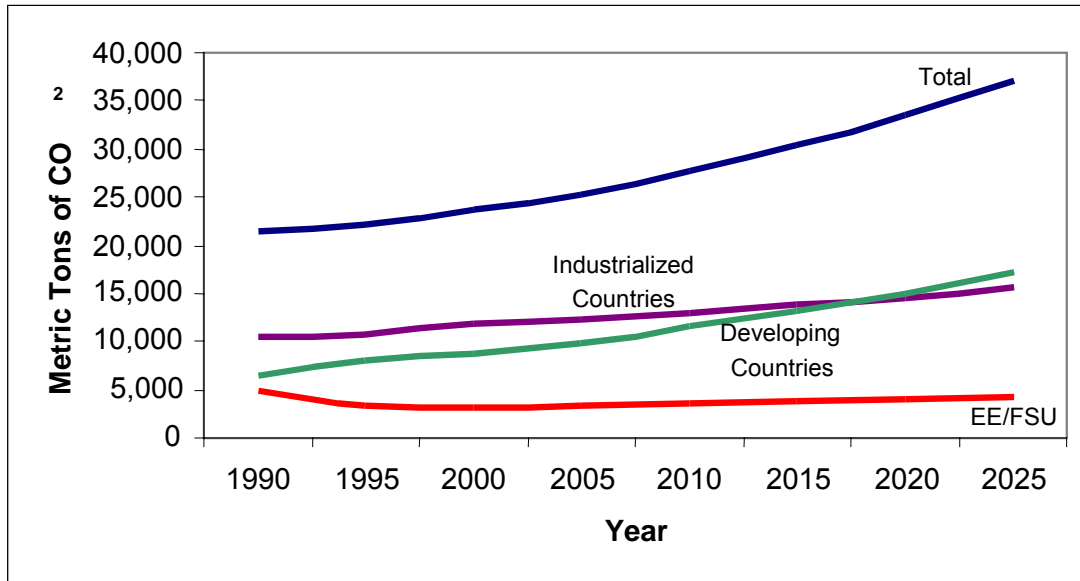

Figure 1.1 World Carbon Dioxide Emissions 1990-2025

Source: EIA 2003a, 2004c

1.2 The Kyoto Protocol

In order to address the global climate change issue, international cooperation has been forthcoming in the last fifteen years. In 1988, the World Meteorological Organization (WMO) and the United Nations Environment Program (UNEP) established the Intergovernmental Panel on Climate Change (IPCC) to assess relevant information on climate change, its impacts, adaptation and mitigation. A global agreement to mitigate climate change was proposed. This led to the United Nations Framework Convention on Climate Change (UNFCCC) which was universally accepted in 1992 at the Earth Summit in Rio de Janeiro. A Conference of the Parties (CoP) to the UNFCCC is held at least once a year, and at the third CoP in 1997 in Kyoto, Japan, the Kyoto Protocol was adopted, which defines policies to reduce GHG emissions.

According to the Kyoto Protocol, there are six gases listed as greenhouse gases, namely carbon dioxide (CO₂), methane (CH₄), nitrous oxide (N₂O), sulphur hexafluoride (SF₆), hydrofluorocarbons (HFCs) and perfluorocarbons (PFCs) families. The first three are estimated to account for 50, 18 and 6 percent of the overall global warming effect arising from human activities (UNFCCC, 2003). To make them comparable, adjusted rates have been defined in terms of Global Warming Potential (GWP) as shown on the Table 1.1.

Table 1.1 Greenhouse Gases and Global Warming Potentials

Gas	Recommended GWP (UNFCCC, 2002); applicable through 2012	IPCC Revised GWP (IPCC's Third Assessment Report, 2001); likely to be applicable after 2012
Carbon dioxide (CO ₂)	1	1
Methane (CH ₄)	21	23
Nitrous oxide (N ₂ O)	310	296
Hydrofluorocarbons (HFCs)	140 – 11900	120 – 12000
Perfluorocarbons (PFCs)	6500 - 9200	5700 - 11900
Sulphur hexafluoride (SF ₆)	23900	22200

Source: Shires & Loughran 2004, Houghton 2004

In the years 2008 – 2012 (also known as the first commitment period), 38 industrialised countries (listed under Annex I of the Climate Convention) have obligations to reduce their greenhouse gas emissions. Each country has a different emission reduction commitment, which appears in Annex B of the Kyoto Protocol. In total, reductions should reach a level of 5.2 % less than developed countries' total emissions in 1990.

A very essential part of the Protocol is its 'flexibility mechanisms':

- **International Emission Trading (IET)**, where industrialised countries can trade part of the emission budgets between themselves
- **Joint Implementation (JI)** allows industrialised countries to get emission credits from emission reduction projects in other Annex I countries
- **Clean Development Mechanism (CDM)** permits industrialised countries to get emission credits from emission reduction projects in developing countries

The justification of these three mechanisms is that greenhouse gas emissions are a global problem and it does not matter where reductions are achieved. In this way, mitigations can be made in another country, where costs are the lowest. The flexible mechanisms, their participants, and commodities traded are summarized in Table 1.2.

Table 1.2 Flexible Mechanisms of the Kyoto Protocol

Mechanism	Participants	Commodity traded
IET	Annex I countries	Assigned Amount Units (AAU)
JI	Annex I countries	Emission Reduction Units (ERU) from specific projects
CDM	Host: non-Annex I countries Investor: Annex I countries	Certified Emission Reductions (CER) from specific projects

To legally enter into force, the Kyoto Protocol must be ratified by at least 55 countries and include no less than 55% of the CO₂ emissions from industrialised/Annex B countries in 1990. The latest information from the UNFCCC shows that by October 5, 2004, 126 countries have ratified or acceded to the Kyoto Protocol. With the Russian parliament having ratified the Protocol on October 22, 2004, 61.2% of emissions from Annex B countries is included. The Protocol enters into force 90 days after the United Nations in New York receive Russia's instrument of ratification.

1.3 Clean Development Mechanism (CDM)

The Clean Development Mechanism (CDM) is the only mechanism in the Kyoto Protocol that gives developing countries the opportunity to be directly involved in implementation of the Protocol. The Annex I countries may invest on emission reduction projects in developing countries and get the certified emission reductions (CERs). One unit of CER equals to one metric ton of CO₂ equivalent, calculated according the Global Warming Potential (GWP, see Table 1.1).

Through inflow of capital and technology the non-Annex I, countries will receive financial and technological assistance to achieve sustainable development (see Kyoto Protocol Article 12, UNFCCC, 1997).

Although the Kyoto Protocol has not yet entered into force, there have been a number of project activities to promote CDM in various developing countries over the last few years. It should be noted that projects starting from the year 2000 onward might be eligible as projects under the CDM and can immediately generate CERs.

CDM can be implemented in several different structures: unilateral, bilateral and multilateral. In a unilateral mechanism, the host country designs and finances the project. It has to take all the risk, but also keeps the profits. Concerning the bilateral

structure, cost and credit emission reductions are shared based on the agreement between the hosts and Annex I countries. The same applies to the multilateral structure as well, but here the number of Annex I countries involved is more than one.

The projects themselves can be held in the energy sector, industrial process, solvent and other product use, agriculture, waste, land use and forestry.

To be able to participate in CDM, the countries must have ratified the Kyoto Protocol and established a Designated National Authority (DNA), responsible for approving and evaluating CDM projects. Furthermore, only Annex I Parties who meet the following criteria are eligible to take part in CDM (Lopes, 2002):

- have their assigned amounts properly calculated and registered
- have a national accounting system of GHG in place
- have created a National Registry
- have submitted a national GHG inventory to the UNFCCC

The UNFCCC's Conference of the Parties (CoP) and the CDM Executive Board (EB), which is a body consisting of ten elected representatives of Kyoto Protocol parties, are responsible for guidance and supervision of CDM projects, while the Designated Operational Entities (DOE), made up of independent certifiers, does the auditing.

Before validating or registering a CDM project, a Project Participant (PP) has to use a methodology previously approved by EB, which must be made publicly available along with any relevant guidance. Otherwise a new methodology for consideration and approval must be proposed, if appropriate (UNFCCC, 2004d). After the methodologies are approved, the designated operational entities may proceed with the validation of the CDM project activity and submit a project design document (CDM-PDD) for registration. The new baseline methodology shall be submitted by the designated operational entity to the Executive Board for review, prior to a validation and submission for registration of this project activity, with the draft project design document (CDM-PDD), including a description of the project and identification of the project participants.

To ensure the credibility and quality of emission reduction, all CDM projects must follow a standardised procedure known as the CDM Project Cycle. The procedure consists of five steps: project development and design, validation / registration, monitoring, verification / certification, and issuance.

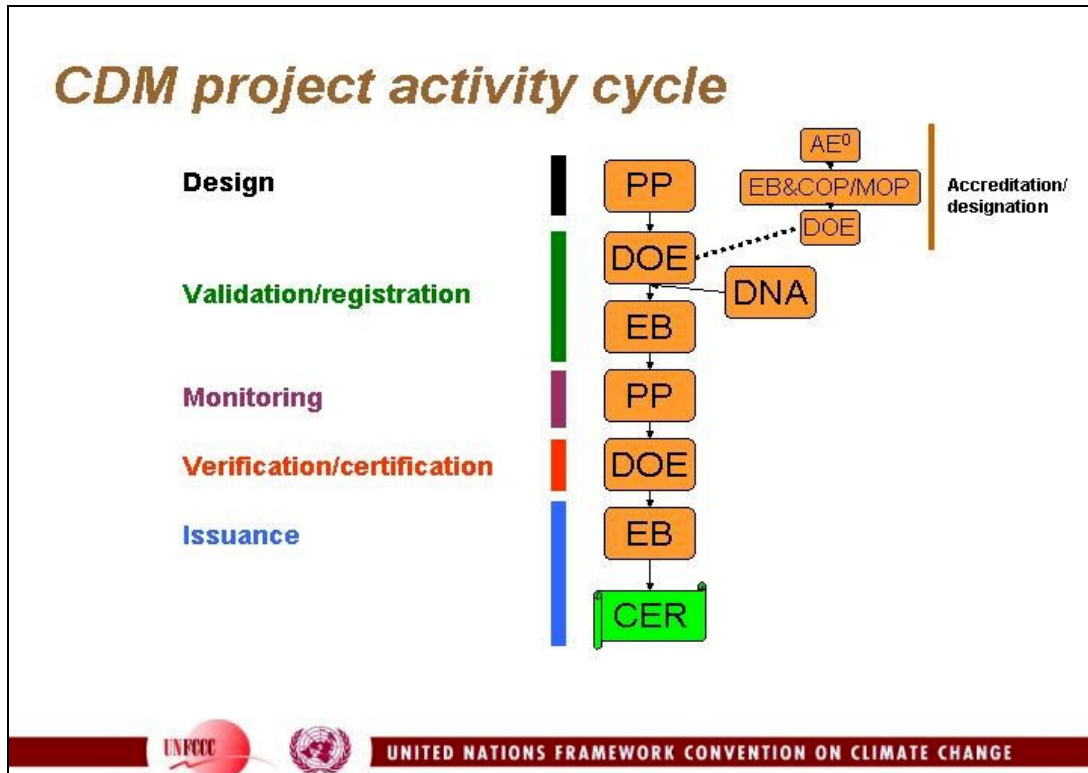

Figure 1.2 The CDM Project Cycle

PP: Project Participant, DOE: Designated Operational Entity, EB: Executive Board, DNA: Designated National Authority, CoP/MoP: Conference of Parties serving as Meeting of Parties, AE: Applicant Entity

Source: UNFCCC, 2004e (<http://cdm.unfccc.int/pac/index.html>)

Project development includes designing a project, obtaining funding, developing baselines, monitoring plans and obtaining host government approval. Then the projects must be validated by an Operational Entity (auditor) and be registered to the CDM Executive Board (EB). The project performance must be monitored and reviewed by the auditor, then the emission reductions must be verified by a designated operational. Before CERs can be issued, they must first be certified by the EB.

In order to enable the pursuit of small projects without going through complicated and expensive processes, the CDM Executive Board has issued a more simple procedure for ‘small-scale’ CDM projects. These kinds of CDM projects include:

- renewable energy projects with a maximum output capacity of up to 15 megawatts
- energy efficiency improvement projects up to 15 gigawatt hours per use
- afforestation or reforestation projects that reduce less than 8 kilo tons of CO₂ per year and are developed or implemented by low-income communities or individuals

- other project activities that both reduce anthropogenic emissions by sources and directly emit less than 15 kilo tons of carbon dioxide equivalent annually.

1.4 Sustainability

The concept of “sustainable development” appeared and became popular for the first time in 1987 in “Our Common Future”, a report of the World Commission on Environment and Development (WCED). This commission, also known as the Brundtland Commission, defined sustainable development as “...*development that meets the needs of the present without compromising the ability of future generations to meet their own needs...*” (WCED, 1987). Since the UN Conference on Environment and Development (UNCED) in Rio de Janeiro (Brazil) in June 1992, there have been numerous attempts to find more operationally useful definitions and indicators of sustainable development. The most common interpretation of this concept consists of three dimensions, known as the sustainability triangle: economy, environment, society (Huq, 2002).

The Kyoto Protocol takes the concept of sustainability into account as well. As mentioned before, an objective of the CDM is to support host countries in the attainment of their sustainable development goals. This means that the countries have the right to accept or reject CDM projects based on their development benefits (Kim, 2004). Each host country will have a different goals, criteria and indicators on defining their sustainable development. For specific CDM projects, countries (and project developers) have defined sustainable development criteria in different ways.

A more detailed discussion on this issue is presented in Chapter 2.

1.5 Oil and Gas

One of the environmental sustainable development criteria is the improved sustainability of natural resources, such as oil and gas. Oil is expected to remain the dominant energy-providing fuel in the world: both its production and consumption are projected to increase by more than 80% from 1990 to 2025 (EIA, 2004a).

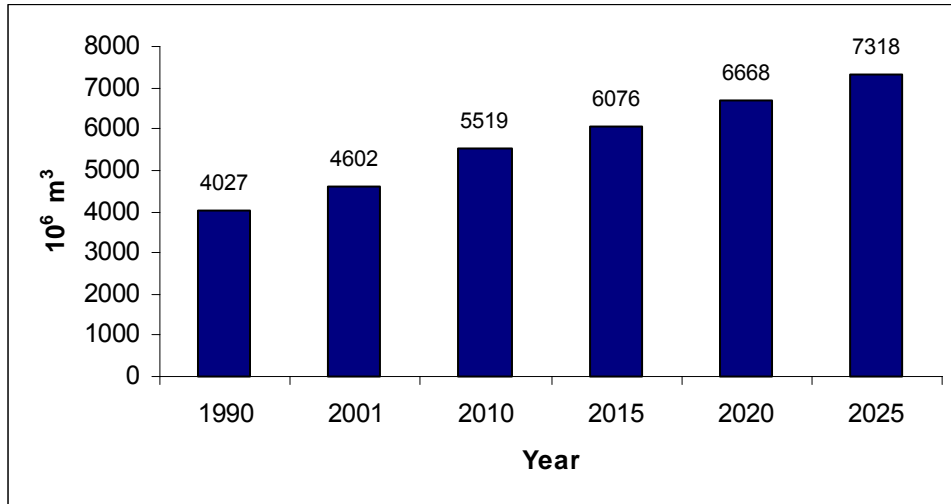

Figure 1.3 World Oil Production

Source: EIA, 2004a

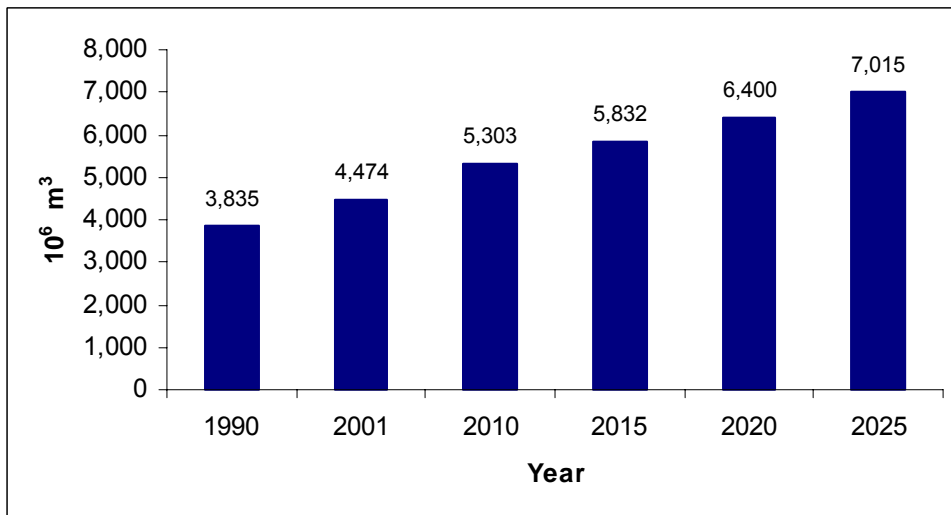

Figure 1.4 World Oil Consumption

Source: EIA, 2004a

However, natural gas is projected to be the fastest growing component of world primary energy. Consumption of natural gas worldwide is projected to increase by an average of 2.2 percent annually from 2001 to 2025, compared with projected annual growth rates of 1.9 percent for oil consumption and 1.6 percent for coal. The natural gas share of total energy consumption is projected to increase from 23 percent in 2001 to 25 percent in 2025. Most of that increase is expected to come from electricity generation.

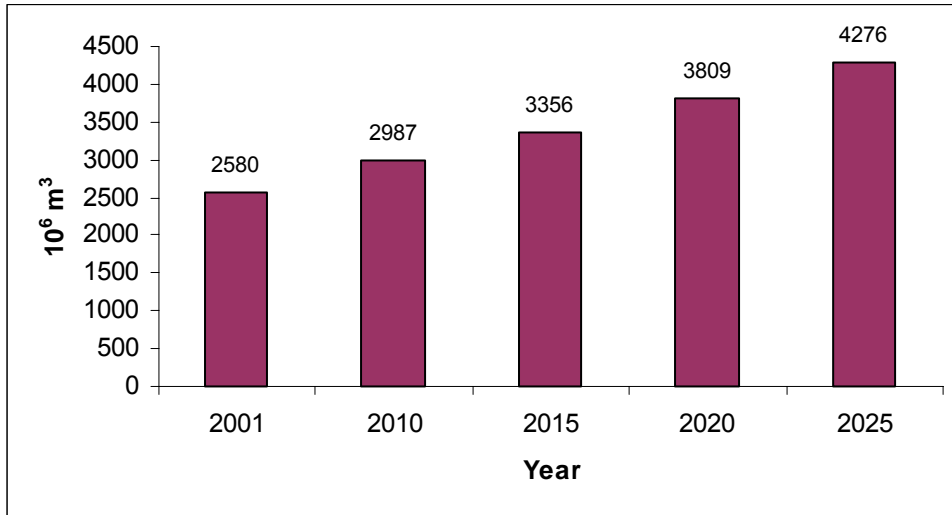

Figure 1.5 World Natural Gas Productions

Source: EIA, 2004a

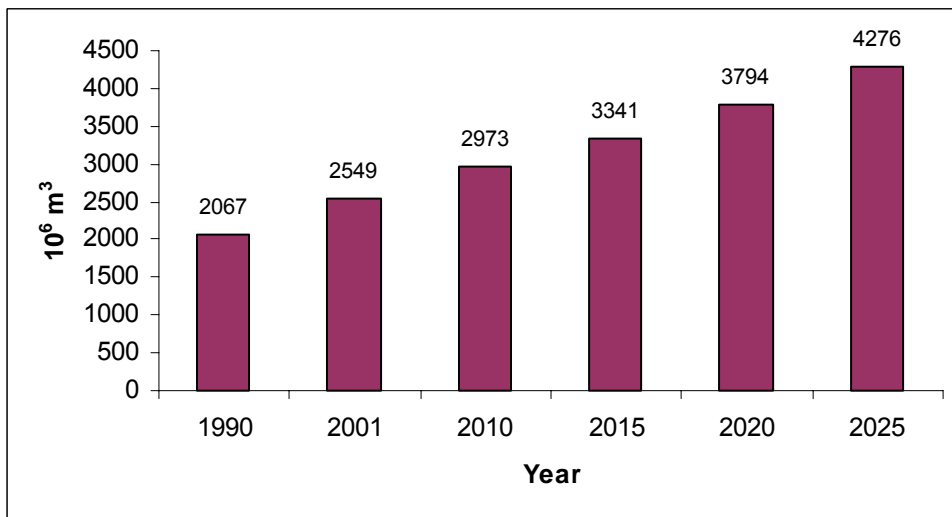

Figure 1.6 World Natural Gas Consumption

Source: EIA, 2004a

One country with substantial oil and gas reserves is Indonesia, which ranks seventeenth among world oil producers and sixth for gas production.

1.6 Indonesian Overview

Indonesia covers 1,919,440 km² over more than 17,000 islands (World Bank, 2004a). Indonesia had 238.5 million inhabitants in July 2004 and the increase in population per year is 1.5%. In 1997 and 1998, the country suffered from a severe economics crisis,

which caused a serious devaluation of the currency, the Rupiah. The current economic situation has improved, although growth is not as rapid as before the crisis. The major export products include manufactured goods, petroleum, natural gas and related products.

Table 1.3 Main Macroeconomics and Development Indicators of Indonesia

GNI, 2002 (US\$ billion)	149.9
GNI per capita, 2002 (US\$)	710
GDP, growth rate, 2003 (%)	4.1
Population density, 2002 (people per sq. km)	117
Crude death rate, 2002 (per 1000 people)	7
Crude birth rate, 2002 (per 1000 people)	20

Source: World Bank, 2004a and CIA, 2004

The country ranks sixth in world gas production, with proven and potential reserves of 4.8 -5.1 trillion cubic meters. Indonesia produces 1.8% of total world oil production, at 160 thousand m³ of oil per day by the end of 2003, but production is decreasing. However, the oil industry remains a key sector that generates strong cash flows. In 2002, oil and gas contributed 21.2 percent of total export earnings and about 25 percent of the government budget (US Embassy, 2004c).

As the world's largest liquefied natural gas (LNG) exporter and due to its OPEC membership and huge oil production, Indonesia is crucial to world energy markets. Indonesia is the only Southeast Asian member of OPEC, and its current OPEC crude oil production quota is 194 thousand cubic meters per day. However, Indonesia still relies on oil to supply its energy needs. The effort to shift towards using natural gas resources for power generation is not being smoothly achieved due to inadequate infrastructure in domestic natural gas distribution.

As a developing country, Indonesia has an opportunity to take part in CDM. In 2001, the Indonesian Ministry for Environment conducted a National Strategy Study (NSS) on CDM in the energy sector in Indonesia, which assessed the potential of CDM in Indonesia and its implementation.

Below are the potential statistics of CDM in Indonesia according to NSS:

- Share of global market: 2% (see Figure 1.7)
- Total Volume : 125-300 Million tons

- Price: US\$ 1.5 - 5/tCO₂
- Potential income: US\$ 187.5 - 1650 million
- Cost: US\$ 106 - 309 million
- Profit: US\$ 81.5 - 1260 million

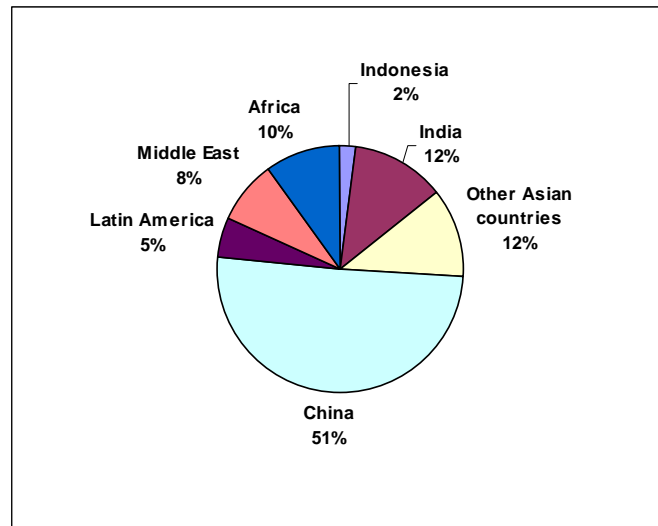

Figure 1.7 Projection of potential income share from CDM in non-Annex I countries

Source: SME – ROI, 2001

To be able to approve projects on CDM, first Indonesia has to have ratified the Protocol and established a Designated National Authority (DNA). On June 28, 2004, the Indonesian House of Representatives ratified the Protocol, and the process of setting up the DNA is currently ongoing. The president of Indonesia formally signs the ratification on October 19, 2004 in the form of ‘*Undang-undang [UU]*’ or national regulation number 17/2004.

1.7 Gas Flaring

When crude oil is brought to the surface, it releases gas components of different hydrocarbons, which is known as associated gas. This gas could be used/sold for energy purposes or be re-injected into the reservoir. Another way to dispose this excess associated gas is by flaring or venting it.

Flare refers to “...an arrangement of piping and a burner to dispose of surplus combustible vapours...” (Tver and Berry, 1980). It is most commonly situated around a gasoline plant, refinery, or production well, where elevated flares are present as tall, chimney-like structures with visible flames at the top. Basically, flaring means the burning of associated gas, while venting is the release of associated gas into the atmosphere. Gas flaring and venting occurs during the drilling and testing of oil and gas wells, and from natural gas pipelines during emergencies, equipment failures and maintenance shutdowns.

According to the World Bank, in the year 2000 worldwide 108 billion cubic meters (bcm) of gas flaring took place, while Indonesia flared 4.5 bcm gas, i.e. 4% of the total. Other big flaring nations include Nigeria, Russia, Algeria and Angola (Gerner, 2004).

The amount of GHG emission from gas flaring and venting depend on gas production, its composition, and the flare efficiency. One of the main problems is the unknown efficiency. It depends on several factors, such as the composition of the flare stream, gas flow rate and wind velocity. The efficiency determines how much gas will be burnt as CO₂, while the rest will be vented as methane, which has a higher greenhouse intensity. Estimations of efficiency range from 20% to 99% and this leads to large uncertainties as to the effects of flaring on the environment (Kostiuk, et al, 2004).

Since each gas flared from different oil fields has its own characteristics, it is not easy to find a definite measurement of its impact. The local effects must be analysed case by case, but in general, flaring releases hazardous chemicals such carcinogens and heavy metals. In addition, its emission of carbon dioxide (CO₂) and methane (CH₄) is a factor of global warming and climate change. In the year 2002, 199 to 262 million tons of CO₂ emissions resulted from gas flaring in the world, i.e. 3% of the total emission (GGFR, 2004). Due to the lack of a global standard and adequate data on gas flaring, there is a possibility that gas flaring could cause more damage than conventionally assumed.

Essentially, the huge amount of the gas being flared could be used for other more productive purposes, such as for power generation. This means that flaring is a waste of

resources. According to EIA 2004, annual flaring will increase by 60% from 1999 to 2020 if there is no effort done to reduce the flaring. However, it is possible to reduce flaring by applying certain policies and strategies (see Figure 1.8, “optimistic scenario”). In addition, the gas utilization in international and domestic markets, site use and reinjection, can also decrease the amount gas flaring.

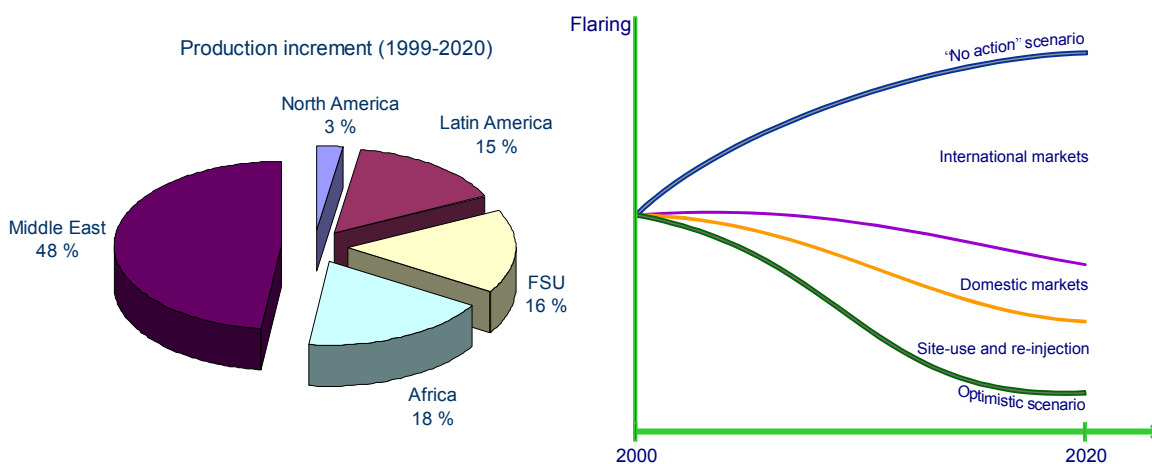

Figure 1.8 Future Oil Production and Flaring Trends

Source: EIA, 2004 and World Bank’s GGFR, 2004f

Many efforts are being made to avoid flaring by gathering excess gas and making commercial use of it, or by reinjecting it into reservoirs. In addition, some countries have introduced a carbon tax, which penalises companies for venting or flaring gas (Jahn et al, 2001), often with little effect. For example, in Nigeria the fee was too low to have an impact on gas flaring and in Norway the CO₂ emission tax was introduced when oil companies’ flaring reduction measures were already well under way (GGFR, 2004f).

Some experiences show that the flaring reduction project will achieve its goals only if it is supported by policy and regulations that create markets, both domestic and international. In many areas of the world, flares are regulated by the local Department of Environmental Control. However, each country, region, and oil company has its own approach and regulations, with different effects and results as well. Therefore, in 2001 the World Bank established the Global Gas Flaring Reduction Public – Private Partnership (GGFR, http://www.worldbank.org/ogmc/global_gas.htm), which aims to support national governments and the petroleum industry in efforts to reduce flaring and

venting of associated gas, for example by developing a (voluntary) standard to promote reduction of flaring.

1.8 Purpose and Outline of the Report

The main objective of this study is to assess the technological and economical feasibility of Clean Development Mechanism (CDM) projects in Indonesia, concerning gas flaring reduction. Analysis will be based on official oil and gas industry data in Indonesia.

The following chapter, Chapter 2, describes the methods to assess CDM in gas flaring reduction.

Chapter 3 outlines data collection and calculations on oil, gas, gas flaring, greenhouse gas emissions and gas-to-oil ratio (GOR) in Indonesia.

Chapter 4 presents the history (and in some cases, projections) of oil and gas production in Indonesia and amounts of gas flaring.

Chapter 5 explains the data and calculations on greenhouse gas emissions from gas flaring, as well as a rough estimation of GOR.

Chapter 6 describes assessment of gas flaring reduction as a CDM option in Indonesia. It presents a discussion about its potential, based on technical and economic points of view.

Chapter 7 briefly describes the facilitation of gas flaring reduction projects in Indonesia.

Chapter 8 summarises the main findings of this study.

2 Methods to Assess CDM in Gas Flaring Reduction

In searching for alternatives to gas flaring reduction, the GGFR suggests the evaluation of oil fields and projects, both from their technological and economic feasibility. From a technical point of view, the type of technology should be optimal in its implementation. In addition, it should be possible to trade carbon reduction both in domestic and international markets.

Many CDM projects are correlated with energy efficiency and renewable energy projects. However, oil and gas projects, particularly gas flaring projects, should also be considered, as they provide significant emission reduction at reasonable costs, can be small-scale, and affect sustainable development. According to the NSS, Indonesia has a potential of GHG reduction through the utilization of flared gas of around 84 million tons of CO₂ with a mitigation cost of US \$ 1.5 / ton CO₂ (SME – ROI, 2001).

One of the crucial constraints in gas flaring reduction is its financial implications. Even though most of the major operators do not have any difficulty to finance a gas flaring reduction project, some smaller companies do face this problem.

Following is the discussion of the current status of CDM rules with regards to gas flaring reduction, focusing on the circumstances in Indonesia.

The CDM's eligibility criteria require a project to show that it supports the host country, i.e. the developing country, in achieving sustainable development. In addition, the activities must result in reduction of greenhouse gases and must be compared with the business as usual (BAU) activities or the baseline (the GHG emissions that would occur in the absence of the project). Furthermore, the project must be technically feasible, comply with regulation, involve the stakeholders and be approved by the host country.

2.1 Sustainable Development

As discussed in the previous chapter, each host country will have different goals, criteria and indicators for defining their sustainable development. Indonesia has structured its criteria of sustainable development, which consists of economic,

environmental, social and technological sustainability (Baiquni, 2004). The complete goals and criteria are available in the Appendix.

Basically any project aiming to reduce gas flaring will comply with and support sustainable development. Nonetheless, it is necessary to ensure that every project takes it into account. Following is the assessment of gas flaring reduction projects compared with the Indonesian sustainable development criteria.

- *Economic sustainability*

Economic sustainability is evaluated in the area within the project's ecological border affected directly by the project activities (Baiquni, 2004). For gas flaring reduction projects, this will cover the oil fields and its surroundings. The evaluation covers community welfare at the area affected directly by the gas flaring project's activities. The CDM project should not lower local communities' income and not lower local public services. Furthermore, adequate measures should be in place to overcome the possible impact of decreases in community members' income. In case of any conflict, an agreement among conflicting parties should be reached, conforming to existing regulations, and dealing with any lay-off problems.

- *Environmental sustainability*

This criterion is also assessed in the area within the project's ecological border affected directly by the project activities. The gas flaring reduction projects should maintain sustainability of local ecological functions and maintain genetic, species, and ecosystem biodiversity and should not permit any genetic pollution. Any emission from the project should not exceed the threshold of existing national, as well as local, environmental standards (not causing air, water and/or soil pollution). In addition, the project design should comply with existing land use planning.

Concerning local health and safety, projects in gas flaring reduction are not allowed to impose any health risk; they should comply with occupational health and safety regulations.

- *Social sustainability*

In implementing a GFR project, the local community must be consulted and their comments/complaints taken into consideration and responded to. It is hoped that this will present an opportunity for participation on the part of the local population.

- *Technological sustainability*

This addresses the technology transfer on a national level. The implementation of gas flaring reduction projects will cause a transfer of know-how from non-local parties, i.e. developed countries. In addition, the local technology will be taken into account due to the specific technical characteristics in each field. It will cause a ‘balance’ in technological implementation. However, it should be kept in mind that experimental or obsolete technologies are now allowed to be used.

2.2 Reduction of GHG Emission – Additionality and Baseline

According to the Kyoto Protocol, CDM projects should result in: “Real, measurable and long-term benefits related to the mitigation of climate change; Reductions in emissions that are additional to any that would occur in the absence of the certified project activity” (Art. 12, 5, b+c). The project is considered to have additional effects only if it is not in the baseline and has lower emissions of GHGs than that of the baseline.

A CDM project in gas flaring reduction should show that it reduces greenhouse gas emissions to a level lower than if the project didn’t exist. Figure 2.1 depicts how to calculate the GHG emission reduction. The current conditions, i.e. the emissions occurring without the project, are called baseline emissions (shown by the grey line). The method to establish a baseline is discussed later. The difference between baseline and project emission is the emission reductions which result in Certified Emissions Reductions or CERs (see the yellow area), measured in metric tons of CO₂ equivalent.

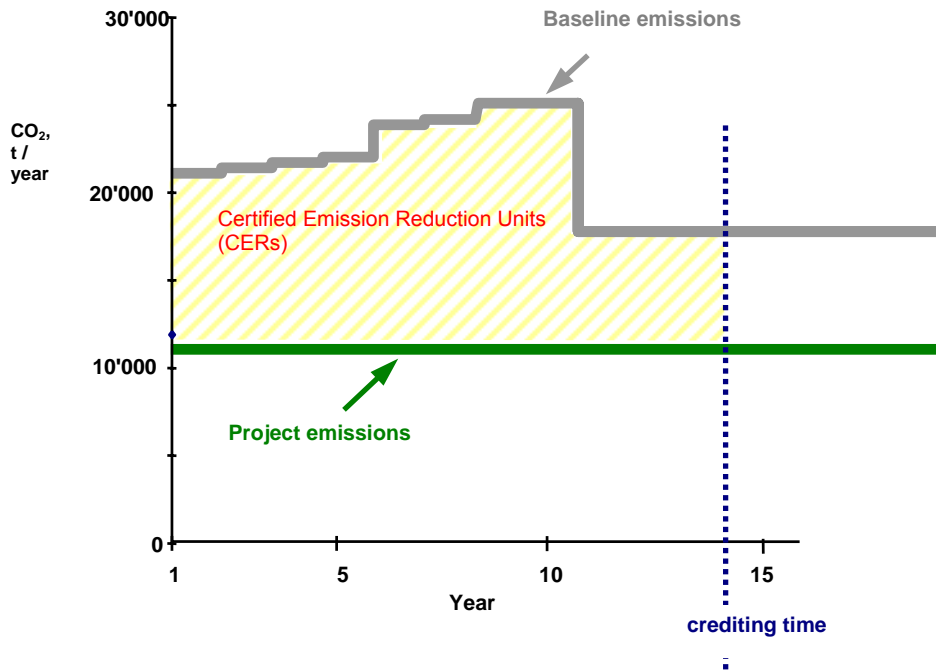

Figure 2.1 Calculation of emission reductions

Source: Sutter, 2004

2.2.1 Additionality Test

There were some concepts of additionality discussed in the negotiations, such as environmental, financial, technology, and regulatory additionality. They partly overlap with investment additionality (Langrock, Michaelowa & Greiner, 2000). Investment additionality means that the project activity, without the support from CDM, would not be undertaken, because of its not being the economically most attractive course of action, while environmental additionality refers to the situation when a project activity causes emission reductions. Another concept is financial additionality, which means that no public money that would have been spent anyway on climate-related action in developing countries could be relabeled as CDM (Dutschke & Michaelowa, 2003).

At first there was not yet a fixed definition of how additionality is measured. However, lately the CDM EB has promoted strict additionality, i.e. the project additionality. To show that a proposed project activity is additional, i.e. is not (part of) the baseline scenario, EB introduces tools that can be used to demonstrate that. In testing the additionality, the focus should be on developing a simple additionality test that is able to distinguish additional projects from non-additional ones (Michaelowa, 1999).

During its 15th meeting in September 2004, the Executive Board of the CDM made a draft of tools to show the additionality of CDM project activities. It was published for comment and was discussed during the meeting in October 2004. These tools can be accessed at <http://cdm.unfccc.int/EB/Meetings/016/eb16repan1.pdf> and consist of the identification of alternatives to the project activity, investment analysis to determine that the proposed project activity is not the most economically or financially attractive, barrier analysis, common practice analysis, and the impact of registration of the proposed project activity as a CDM project activity.

- *Identification of alternatives to the project activity consistent with current law and regulations*

The step determining whether the project is required under existing regulation is a central aspect of additionality. If there is no current policy regulating this, the project is presumably additional. Some cases from Canada, Norway and the United Kingdom show that regulation plays an important role in achieving reduction in flaring volumes (World Bank, 2004e).

Regulations on oil production and gas flaring aim to establish standards and guidelines to achieve environmental, safety and health objectives. They should be clear and efficient, establish transparent gas flaring and venting application and approval, and project implementations should be monitored. The regulators are supposedly the ministry responsible for managing the country's hydrocarbon resources. Indonesia, as an oil-producing country, unfortunately doesn't have specific guidelines and clear emission policies yet. However, there are several countries/regions that are currently succeeding in implementing regulations in gas flaring.

For example, the government of the province of Alberta, Canada, set upstream petroleum industry gas flaring and venting targets. The Alberta Energy and Utilities Board (EUB) provides Guide 60 for flaring, incinerating and venting in Alberta, as well as procedural information for flare permit applications, measuring and reporting of flared and vented gas.

Some countries have various regulations that are connected to flaring, and flaring may take place only after approval by a regulatory body. But the regulation is often vague and varies from case to case, which makes it difficult to assess the baseline and additionality of projects.

An alternative solution is to have a control group, as shown by a project of biomethanation of municipal solid waste in India (AM0012 http://cdm.unfccc.int/UserManagement/FileStorage/CDMWF_AM_627397095).

Recognizing the increasing problem of unmanaged waste sites, the Ministry of Environment and Forests issued the Municipal Solid Wastes (Management and Handling) Rules (2000). However, the regulation is poorly enforced. For this purpose, it proposes some control groups. The additionality of the project activity must be assessed by taking into account the revenue from electricity generation and organic fertilizer, regardless of whether credit is to be claimed for these components or not. The compliance rate is based on the annual reporting of the State Pollution Control Board. This organization monitors and reports the compliance level based on the annual compliance reports by municipalities and corporation. The state-level aggregation involves all landfill sites except for the site of the project. If the rate exceeds 50%, no CERs can be claimed.

- *Investment analysis*

After a project passes the first additionality test, it can be assessed economically and financially. Firstly the appropriate analysis method needs to be determined: simple cost analysis, investment comparison analysis or benchmark analysis. If the CDM project activity generates no financial or economic benefits other than CDM related income, then the simple cost analysis should be applied. Otherwise, the investment comparison analysis or the benchmark analysis should be used.

In using investment comparison analysis, the financial indicators such as IRR, NPV, cost benefit ratio, or unit cost of service must be identified. This is also true for benchmark analysis, but in addition the relevant benchmark as standard return in market needs to be identified.

All investment analysis must be presented in PDD, and include a sensitivity analysis that shows whether the conclusion regarding the financial attractiveness is robust to reasonable variations in the critical assumptions. If, after the sensitivity analysis, it is concluded that the proposed CDM project activity is unlikely to be the most financially attractive or is unlikely to be financially feasible, or can proceed to common practice analysis. Otherwise, the project activity is considered not additional.

- *Barrier analysis*

This is used to determine whether the project faces investment, technological or other barriers that could impact the project implementation. The key issue is how important barriers are (Michaelowa & Jung, 2003). Financially viable projects may be eligible if barriers can be documented, and the combination of CDM as an institution, the project design and credits overcome the barriers.

- *Common practice analysis*

This is complementary to the additionality tests' previous steps. Common practice analysis checks the common practice in the relevant sector and region. The identification should include analysis of other activities similar to the proposed project activity and discussion regarding any similar options that are underway. If similar activities cannot be observed, or if similar activities are observed, but essential distinctions between the project activity and the observed activities can reasonably be explained, then this additionality test can be continued to the last step. If similar activities can be observed and essential distinctions between the project activity and similar activities cannot be reasonably explained, the proposed CDM project activity is not additional.

- *Impact of CDM registration*

The approval and registration of the project activity as a CDM activity, and the attendant benefits and incentives derived from the project activity, should ease the economic and financial hurdles or other identified barriers. Otherwise, the project is not additional.

2.2.2 Baseline

Under project-related mechanisms to reduce greenhouse gas emissions, emission reductions can only be calculated from a reference basis of emissions, the *baseline*. An overall definition of a baseline would be the emissions level if the project had not taken place (Michaelowa, 1999).

The most crucial component for determining additionality is the baseline setting. A baseline methodology is used to select a baseline scenario, calculate baseline emissions and determine project additionality.

Until September 2004, the CDM Executive Board has approved one baseline methodology for flaring reduction projects, namely the Rang Dong project in Vietnam (AM0009

http://cdm.unfccc.int/UserManagement/FileStorage/CDMWF_AM_577581847,

approved during the 13th meeting in March 2004).

To establish the baseline for gas flaring reduction projects, there are some basic steps to follow:

- Set the project boundary (connection to the existing gas network)
- Estimate gross reduction of carbon emissions based on production and current flaring efficiency
- Estimate net reduction of carbon emissions (on site energy use and fugitive emissions, if any)
- Determine leakage (emission from outside project boundary which affects the project's total emission)

Following is the summary of existing baseline methodology for gas flaring reduction, i.e. Rang Dong methodology.

This methodology can be used for gas recovery projects if it is transported to a process plant where dry gas, LPG and condensate are produced, which are used as alternative fuel. The energy required for transport and processing of the recovered gas comes from the recovered gas itself and in the absence of the project activity, the gas is mainly flared. Therefore this project reduces GHG emissions.

The baseline and project emissions are calculated based on the gas recovered and oil production. Since the projection will engage some uncertainties, the results from calculations are adjusted during the project implementation and monitoring.

The calculations of emissions cover the emission of greenhouse gases from fuel consumption and combustion and emission from leak, venting and flaring. However, these emissions are considered as part of project boundary only if the sources are under control of the project participants. Otherwise, those emissions are calculated as leakage effects.

The detailed calculations and estimations of CO₂ emissions, CH₄ emissions from recovery and processing the gas, CH₄ emissions from transport of the gas in pipelines as well as the projects' emission reductions are calculated as the difference between baseline and project emissions, taking into account any adjustments for leakage, are

discussed in this methodology. In calculating baseline emissions, it is assumed that the recovered gas would mainly be flared in the absence of the project. In practice, flaring is often conducted under sub-optimal combustion conditions and part of the gas is not combusted, but released as methane and other volatile gases. However, measuring the quantity of methane released from flaring is difficult. Therefore in this methodology, a conservative assumption is made by converting all carbon in the gas into carbon dioxide.

The gas flaring reduction projects are considered to be additional after formulating the most likely course of action, taking into account economic attractiveness and barriers. There are some options in dealing with associated gas at oil fields, such as venting, flaring, on-site consumption, re-injection and recovery-transportation-processing-distribution to end-users. The additionality assessment consists of economic attractiveness and a comparison of legal aspects should be made for every option.

The legal aspects can be evaluated by assessing the law, agreements and standards which permit or implicitly restrict certain options. The options which are legally permitted by law or other agreements and standards are then examined for their economic attractiveness.

The overall projected gas production, projected quantity of recovery gas, price, net calorific value of the gas, CAPEX and OPEX should be taken into account in calculating the Internal Rate of Return (IRR) of each option. The option that is economically the most attractive course of action is considered as the baseline scenario. To apply the methodology project participants should demonstrate that flaring is the baseline scenario. The project activity can be considered additional, if the IRR of the project activity is lower than the hurdle rate of the project participants (typically about 10%). The DOE should verify what value for the IRR is typical for this type of investment in the respective country. The calculations should be described and documented transparently.

During the project implementation, monitoring should be done on the composition and quantity of recovered gas and products (dry gas, LPG, condensate). In addition, the quantity of any fuel consumption must be taken into account, as well as the leakage of CH₄ emission.

2.3 Institutional Risk and Uncertainties

The implementation of CDM procedures in Indonesia still faces high barriers. Aside from the time and money needed to implement projects under CDM, some risks and uncertainties due to the barriers result in a relatively undeveloped CDM market. Another problem is risk and uncertainties connected with the institutions.

The Indonesian Parliament (Dewan Perwakilan Rakyat – DPR) passed a new oil and gas law in October 2001, which ended Pertamina’s monopoly over downstream oil distribution and marketing of fuel products (US Embassy, 2004c). The new law created two new governmental bodies: the Executive Body (BPMIGAS) that takes over Pertamina’s upstream functions to manage the Production Sharing Contracts (PSCs) and the Regulatory Body (BPH Migas) that supervises downstream operations. However, the government has not yet completed its implementing regulations for the upstream and downstream sectors, which were due by the end of 2003. On the other hand, all energy activities dealing with petroleum and gas fall under the Ministry of Energy and Mineral Resources, in which one of its directorates (the Directorate General of Oil and Gas or MIGAS) is responsible for all aspects of the petroleum industry.

This transition phase creates a barrier to the start of a CDM project in gas flaring reduction. The unclear regulations concerning job descriptions of those institutions makes it difficult to know who is responsible to do what task and overlapping is unavoidable. Concerning the CDM, it is not yet clear who will deal with the buyer, because all PSC’s upstream activities in Indonesia is under the management of BPMIGAS.

Another issue regarding CDM in GFR is the CER ownership. According to the law, Indonesia’s mineral resources are owned by the State. Gas flaring reduction projects have much potential in Indonesia, however there are “policy barriers”; current regulation allows PSC to trade oil and gas only. In addition, due to the implementation of a new fiscal decentralisation law in January 2001, revenue-sharing formulas came into effect that directed 15 percent of the Indonesian government’s net oil revenues and 30 percent of its net natural gas revenues to provincial and district governments. This makes the issue of CER ownership more complicated, even though PSC structure clearly describes risk and benefit sharing terms. According to Newell (2004), since capital investment that produces credits is treated in accordance with PSC terms, it is reasonable that PSC profit split should be used for carbon credits as well.

2.4 Carbon Market Development

Despite the fact that the Kyoto Protocol has not yet entered into force, there are already some carbon submarkets and purchasers, with national, domestic and international market as the principal markets:

- International market consisting of JI and CDM projects. The purchasers are, for example, PCF/World Bank, Dutch Government, other European Governments, and private companies
- National/domestic market, such as the UK, Denmark, EU
- In-house internal trading scheme
- Offsets of retail/consumer and voluntary actions

Figure 2.2 shows that the market has been increasing since 2001, from around 15 million tCO₂e in 2001, to almost 80 million in 2003, and 65 million in May 2004 (Carbon Finance, 2004). The projects are classified into two types: the ones intended for compliance under the Kyoto Protocol, i.e. intended for registration under JI or CDM, and those not intended for compliance with the Kyoto Protocol.

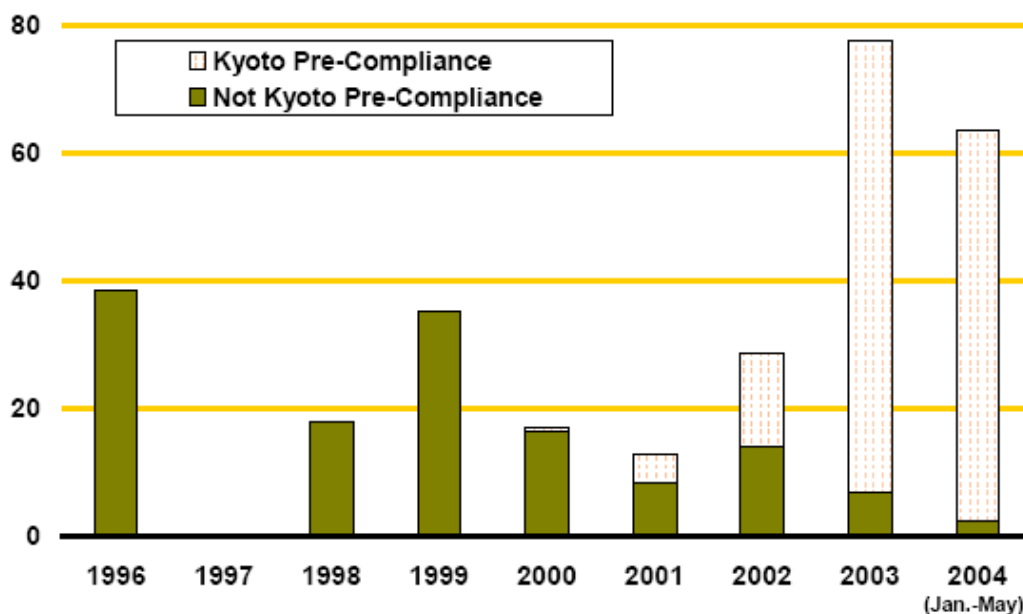

Figure 2.2 The Carbon Volume Traded in Current Carbon Market (million tons CO₂ eq)

Source: Carbon Finance, 2004

Another estimation was made by Point Carbon which shows that for JI and CDM projects, from January until October 2004, more than 30 million tons of CO₂ eq were traded. It also predicts the amount of CER delivered until 2006, as shown in Figure 2.3.

It is difficult to estimate the volume of CERs to be procured by Annex I Parties in the first Kyoto commitment period (Point Carbon, 2003). A rough estimation suggests that Annex I Parties currently plan to acquire CERs equaling about 100 MtCO₂e. The Netherlands are by far the most advanced among the actors that have so far published plans for acquiring CERs, although countries such as Canada and Denmark have recently increased their focus on CER procurement.

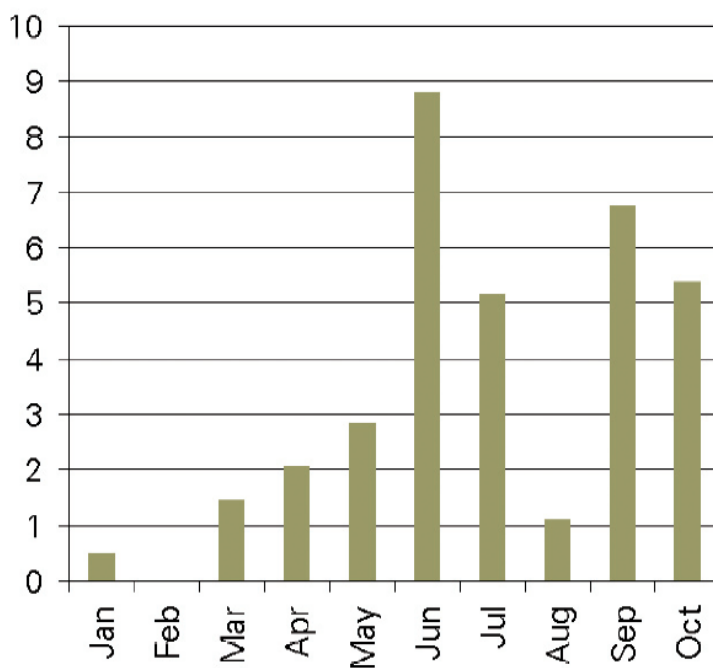

Figure 2.3 JI and CDM Investments Monthly in 2004 (million tons of CO₂ equivalent)

Source: Point Carbon, 2004

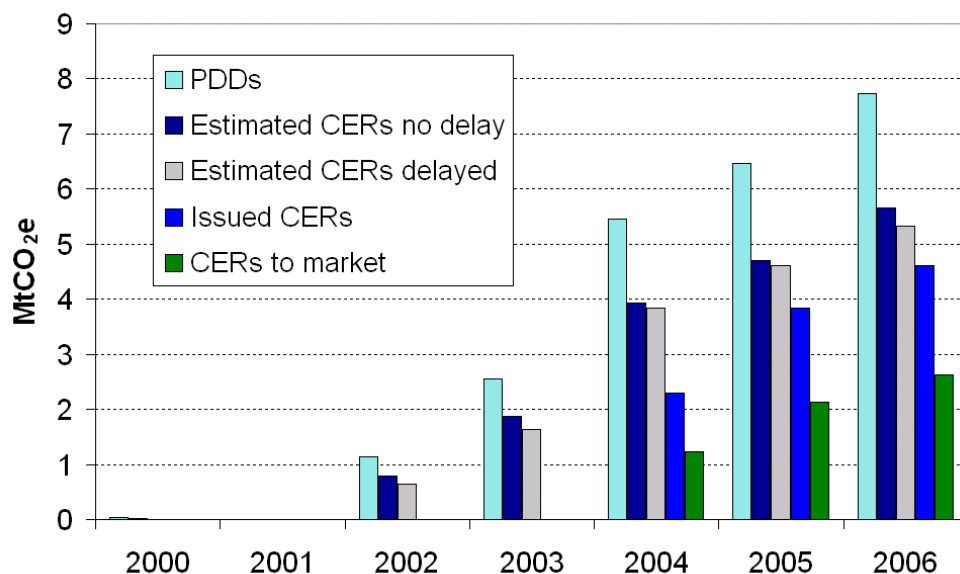

Figure 2.4 Historical and Projection of CER Amount

Source: Point Carbon, 2003

In the beginning, generally both buyers and sellers were located in industrialised countries. However, the market share in transition economies and developing countries rose from 38 percent in 2001 to 90 percent over the first quarters of 2004. The three largest suppliers (India, Brazil and Chile) account for 56% of the total volume delivered over that period, and the top five (which include also Romania and Indonesia) account for two-thirds. It is estimated that more clear rules and trading schemes in Europe, Canada and possibly Japan will drive the market to increase even more (Lecocq, 2003).

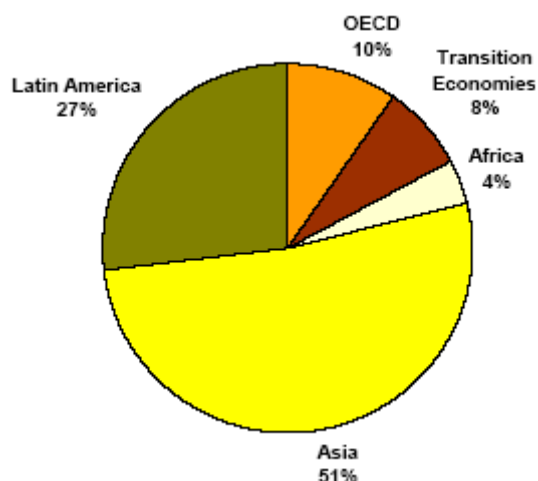

Figure 2.5 The Sellers (2003 – May 2004)

Source: Carbon Finance, 2004

The market for JI and CDM transactions is likely to grow steadily, due to the purchase orders from Japanese and European companies (Lecocq, 2004). Another major reason is that European governments have at least signaled their willingness to enter the market.

Since the total volume of emission reductions by 2012 will be no higher than 10% of the anticipated demand for emission reductions from countries in Annex B of the Kyoto Protocol (excluding the U.S. and Australia), there is a huge opportunity for a growing market. In addition, the thought that the participation in the carbon market is 'risky' due to uncertainty regarding the timing of Kyoto Protocol most likely will be solved in the near future, since Russia ratified the Protocol in October 2004. As the prospects of the entry into force of the Kyoto Protocol by the announced ratification of Russia are improving, carbon markets are emerging as a consequence of the flexible mechanisms, with different types of tradable emissions permits as commodities and allowances (Point Carbon, 2004)

2.5 Current CDM Activities in GFR in Indonesia

The basic flow of oil and gas industry in Indonesia is shown in Figure 2. According to BPMIGAS (2004), some gas flaring reduction efforts which already exist, i.e. building some utilization facilities for electric/steam generators and LPG plants, could be developed as a CDM project. In addition, the re-injection of associated gas in the field is becoming one alternative to reduce gas flaring. The gas market also exists outside the field, such as the power generator in Java and Bali, as well as the opportunity to export gas to neighbour countries, e.g. Singapore and Malaysia.

This is discussed in detail in Chapter 6. In addition, Indonesia is currently a member of the World Bank's Global Gas Flaring Reduction Partnership (GGFR, http://www.worldbank.org/ogmc/global_gas.htm), which aims to support national governments and the petroleum industry in reducing flaring and venting of associated gas.

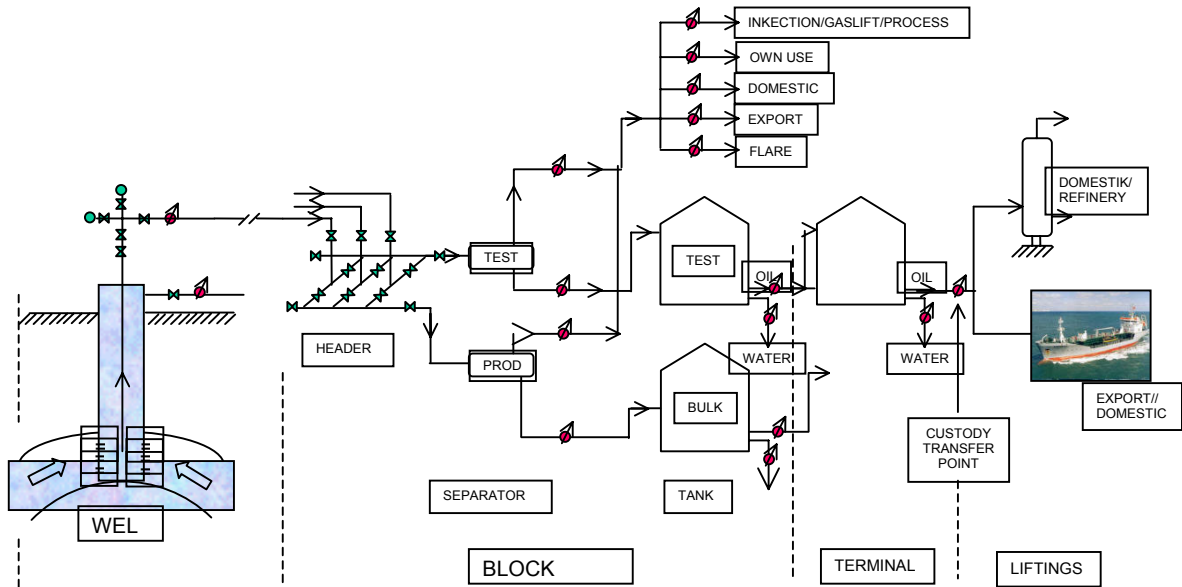

Figure 2.6 Oil and Gas Flow Diagram

Source: BPMIGAS, 2004

Concerning the market for gas flaring, Indonesia is the biggest GHG emitter from gas flaring in Asia, with a contribution of more than 70% per year. This means that Indonesia has a higher opportunity than other countries to utilize CDM projects, as long as circumstances in Indonesia support opening the market, for example by establishing clear regulations on gas flaring reduction and market. There are 10 million tons CO₂ eq in 2003 (it is not impossible that the real number is bigger than reported). Actually, the initial steps in starting a gas flaring reduction project under CDM have already been started by a company in Kalimantan, Indonesia. Most of the initiative of CDM in GFR in Indonesia are done by large companies, because there is less risk in project financing and a larger amount of CER. Existing projects are discussed in Chapter 6.

3 Data Collecting and Calculations

This study collects and analyses Indonesian data on oil, gas, gas flaring and its greenhouse gas emissions. To differentiate the data taken directly from other references and data acquired from own calculations, the data sets will be presented in two separate chapters. Data on oil, gas and gas flaring from official sources is discussed in Chapter 4, while data on greenhouse gas emissions is presented in Chapter 5. In addition, a rough estimation of gas-to-oil ratio (GOR) will be presented in Chapter 5 as well. This calculation of GOR aims to find out the reservoir fluids types, predict fluid behavior during production and determine how this influences field development planning. From GOR, the volume of associated gas produced per unit of oil produced can be estimated. If the amount of gas flaring is known, its share of the total can be estimated, as well as its projection in the future, and its GHG emission. Therefore the potential of those oil fields to have CDM projects can be estimated. Following are the explanations of the sources, units and calculations used.

3.1 General

3.1.1 Data Sources and Quality

The main objective of this data collection is to have complete information from the year 1990, i.e. the baseline year, until 2012 (end of the first commitment period). However, some factors made this difficult to achieve:

- There is not enough data available from the primary sources, i.e. official national authorities (BPMIGAS, Ditjen MIGAS) and oil companies
- First hand data is not easy to collect, due to the formality of procedures which takes time
- Often it happens that various sources provide different number(s) for the same type of data

The following procedures were developed to solve those constraints:

- First priority: using direct official data, i.e. from national authority (BPMIGAS, Ditjen MIGAS and State Ministry of Environment) and oil companies. If there is any double entry, the most up-to-date data will be chosen. The reliability of these data sets must be reconfirmed, as well as compared with each other and with data from other sources.

- Second priority: as there is no direct data from primary sources, using data from official websites/reports, such as BPMIGAS' site and published statements. If there is any double entry, the most up-to-date data will be chosen
- Third priority: using data from other organisations/institutions such as EIA, US Embassy

3.1.2 Data from BPMIGAS

BPMIGAS, as the Indonesian national executive body that regulates downstream activities, is considered as the main data source in this study.

After several attempts to collect information from BPMIGAS, at the end this institution provided three sets of data. The insufficient data management in Indonesia make it difficult to have exactly one database. Sometimes each national authority has its own data. Since the passage of a new law in oil and gas in 2001, most data are collected in BPMIGAS, including historical data from different sources.

Each set contains different elements as described in Table 3.1; presumably, they are aimed to complement each other. For example, the oil production from first set show detail data from every field, while the second set provide data per company only. However, sometimes each set provides different number(s) for the same type of data, such as first set shows that company Z has an amount of A for gas production in year 19XX while second set shows an amount of B.

Table 3.1 Available Data from BPMIGAS

	1 st data set 1993 – 2003	2 nd data set 1966 – 2002	3 rd data set 1996 – 2003
Oil production	√	√	-
Gas production	√	-	√
Gas flaring	-	-	√

It should be noted that each of the sets containing oil and gas productions data has different numbers. Therefore, it is preferred to put as much effort as possible to use data from the same set.

In addition, availability data from each field and company is inconsistent for every year. There is no complete data for each company, and the fields/companies change due to acquisitions and mergers. In the course of this thesis, it is not possible to recheck and investigate all differences/changes as this can only be done in Indonesia. However, all possible efforts were made to provide as accurate data as possible.

Due to confidentiality requirements, all company names and field locations have been changed. For each company, a code name consisting of two letters is assigned, for example OC, AM. Every field will have the code for its company and a number, for example, the fields belonging to AM will have code of AM – 1, AM – 2, etc.

To find out the accuracy of the companies' oil, gas and flaring data from BPMIGAS, it would have to be confirmed directly with the oil companies. However, this data was obtained almost at the end of the allocated time for data collecting, therefore it was not possible to contact and recheck its accuracy with the oil companies.

3.1.3 Units and Conversion

Most of the sources use the common units of the petroleum industry, i.e. non-SI units. However, this study uses SI units in order to meet EB's requirement (see EB 09 Report, Annex 3, Point 6 <http://cdm.unfccc.int/EB/Meetings/009/eb09repa3.pdf>). With consideration that most of the readers are from the oil and gas industry, who are more accustomed with non-SI units, a conversion table is provided in this section to make it easier to convert the figures.

The units of measurement in this study are:

- m^3 = cubic meters
- ton of CO_2 equivalent

Table 3.2 Conversion Factors

	Common US Units	SI Units	Other Conversions
Mass		1 kilogram	= 2.20462 pounds (lb) = 1000* grams (g)
	1 pound (lb)	= 0.4535924 kilograms	= 453.5924 grams (g)
	1 short ton (ton)	= 907.1847 kilograms	= 2000* pounds (lb)
	1 metric ton (ton)	= 1000* kilograms	= 2204.62 pounds (lb) = 1.10231 tons
Volume		1 cubic meter (m ³)	= 1000 *liters (L) = 35.3147 cubic feet (ft ³) = 264.17 gallons
	1 cubic foot (ft ³)	= 0.02831685 cubic meters (m ³)	= 28.31685 liters (L) = 7.4805 gallons
	1 gallon (gal)	3.785412×10 ⁻³ cubic meters (m ³)	= 3.785412 liters (L)
	1 barrel (bbl)	= 0.1589873 cubic meters (m ³)	= 158.9873 liters (L) = 42* gallons (gal)
Length		1 meter (m)	= 3.28084 feet = 6.213712×10 ⁻⁴ miles
	1 inch (in)	= 0.0254* meters (m)	= 2.54* centimeters
	1 foot (ft)	= 0.3048* meters (m)	
	1 mile	= 1609.344* meters (m)	= 1.609344* kilometers

Source: API Compendium, 2004

Table 3.3 Unit Prefixes

SI Units		US Designation	
Unit/Symbol	Factor	Unit/Symbol	Factor
giga (G)	10 ⁹	quadrillion (Q)	10 ¹⁵
mega (M)	10 ⁶	trillion (T)	10 ¹²
kilo (k)	10 ³	billion (B)	10 ⁹
centi (c)	10 ⁻²	million (MM)	10 ⁶
milli (m)	10 ⁻³	thousand (k or M)	10 ³

Source: API Compendium, 2004

3.2 Data on Oil, Gas and Gas Flaring

The oil, gas and gas flaring data were collected from several sources:

- BPMIGAS, Ditjen MIGAS, oil companies
- The National Strategy Study on CDM in Indonesia (2001)
- Other sources: Energy Information Administration (EIA, 2004), US Embassy's Indonesian Petroleum Report (2004)

After reviewing BPMIGAS data sets, it was decided that the first data set is used for oil production 1993 – 2003, the second for oil production 1990 – 1992, the third data set for gas production and gas flaring 1996 – 2003. For other years, the data is obtained from other sources.

Table 3.4 Data Sources for Oil, Gas and Gas Flaring

Year	Oil data	Gas data	Gas Flaring data
1990	Source: BPMIGAS (2 nd set)	Source: MIGAS in US Embassy Report	Source: MIGAS in US Embassy Report
1991			
1992			
1993	Source: BPMIGAS (1 st set)	Source: The 1 st National Communication	No data available
1994			
1995			
1996		Source: BPMIGAS (3 rd set)	Source: BPMIGAS (3 rd set)
1997			
1998			
1999			
2000			
2001			
2002			
2003			

3.3 Data on Greenhouse Gas Emissions

The flaring data from sources mentioned above is used to estimate greenhouse gas emissions in the years 1990 – 2003. Since there is no available flaring data for the years 1994 – 1995, additional information from EIA is used.

The calculations are based on two guides and at the end, both calculations will be compared:

- API Compendium of Greenhouse Gas Emissions Estimation Methodologies for the Oil and Gas Industry (2004). This is the recommended guide from the GGFR.
- Canadian Association of Petroleum Producers (CAPP)'s Guide Calculating Greenhouse Gas Emissions (2003)

For a detailed calculation of specific gas flaring reduction projects, it is recommended to follow the emission calculation contained in Rang Dong Project Methodology (AM0009

http://cdm.unfccc.int/UserManagement/FileStorage/CDMWF_AM_577581847).

3.3.1 Calculation based on API Compendium

The ratio of gas flared to gas vented (flaring efficiency) is crucial to GHG emissions because the impact of vented methane on global warming is about 21 times greater than the impact of CO₂ emissions from fuel combustions. If measured emissions data are unavailable, CO₂ emissions from flares are based on an estimated 98% combustion efficiency for the conversion of flare gas carbon to CO₂. The selection of 98% efficiency is based on general industry practice, which relies on the widely accepted AP-42 document which states: “properly operated flares achieve at least 98 percent combustion efficiency” (EPA, AP-42 Section 13.5.2, September 1991), where 98% efficiency is consistent with the performance of other control devices (API Compendium, 2004). This EPA study concluded that flares had efficiencies greater than 98% for the gas mixtures tested as long as the flame remained stable. (Kostiuk et al, 2004).

The general equations for estimating emissions from flares are:

$$\text{CO}_2 \text{ Emissions} = \text{Volume Flared} \times \text{Molar volume} \times \sum \left(\frac{\text{mole Hydrocarbon}}{\text{mole gas}} \times \frac{X \text{ mole C}}{\text{mole Hydrocarbon}} \right) \\ \times \text{Combustion efficiency} \left(\frac{0.98 \text{ mole CO}_2 \text{ formed}}{\text{mole C combusted}} \right) \times \text{MW CO}_2$$

CH₄ Emissions
 = Volume Flared × CH₄ Mole fraction × % residual CH₄ × Molar volume × MW CH₄

N₂O Emissions = Volume Flared × N₂O emission factor

The value of emission factors are shown in Table 3.5.

Table 3.5 GHG Emission Factors for Gas Flaring

<i>Original units (tons/10⁶ m³ or tons/1000 m³)</i>				
Flare Source	Emission Factors ^a			Units
	CO ₂	CH ₄	N ₂ O	
Flaring - gas production	1.8	1.1E-02	2.1E-05	tons/10 ⁶ m ³ gas production
Flaring - conventional oil production	67.0	5.0E-03 - 2.7E-01	6.4E-04	tons/1000 m ³ conventional oil production
<i>Units Converted to tons/10⁶ scf or tons/1000 bbl</i>				
Flare Source	Emission Factors ^a			Units
	CO ₂	CH ₄	N ₂ O	
Flaring - gas production	5.1E-02	3.1E-04	5.9E-07	tons/10 ⁶ scf gas production
Flaring - conventional oil production	10.7	7.9E-04 - 4.3E-02	1.0E-04	tons/1000 bbl conventional oil production

^a While the presented emission factors may all vary appreciably between countries, the greatest differences are expected to occur with respect to venting and flaring, particularly for oil production due to the potential for significant differences in the amount of gas conservation and utilisation practiced.

Sources: IPCC, 2000; API Compendium, 2004

Using Global Warming Potentials (GWP) values, GHG emissions estimates are often expressed in terms of CO₂ Equivalents or Carbon Equivalents for final summation. For each type of greenhouse gas, a different GWP is applied as defined in Chapter 1 (see Table 1.1).

$$\text{CO}_2 \text{ Equivalents, tonnes} = \sum_{i=1}^{\text{\# Greenhouse Gas Species}} (\text{tons}_i \times \text{GWP}_i)$$

3.3.1.1 Calculation According to Oil Production

Formula:

$$CO_2 : 67 \frac{\text{tons}}{1000 \text{ m}^3 \text{ conventional oil production}} \times \text{oil production}$$

$$CH_4 \text{ min} : 5 \times 10^{-3} \frac{\text{tons}}{1000 \text{ m}^3 \text{ conventional oil production}} \times \text{oil production}$$

$$CH_4 \text{ max} : 2.7 \times 10^{-1} \frac{\text{tons}}{1000 \text{ m}^3 \text{ conventional oil production}} \times \text{oil production}$$

$$N_2O : 6.4 \times 10^{-4} \frac{\text{tons}}{1000 \text{ bbl conventional oil production}} \times \text{oil production}$$

The range in values for CH₄ is due to differences of the amount of gas conservation and utilisation practiced (IPCC, 2000). In this study, the lowest value is chosen to avoid overestimation of CDM potential.

Example:

The oil production in 1990 is 88.84 million m³.

Calculations:

$$CO_2 : 67 \frac{\text{tons}}{1000 \text{ m}^3 \text{ conventional oil production}} \times 88.84 \times 10^6 = \underline{5,952,280 \text{ tons}}$$

$$CH_4 \text{ min} : 5 \times 10^{-3} \frac{\text{tons}}{1000 \text{ m}^3 \text{ conventional oil production}} \times 88.84 \times 10^6 = \underline{442 \text{ tons}}$$

$$CH_4 \text{ max} : 2.7 \times 10^{-1} \frac{\text{tons}}{1000 \text{ m}^3 \text{ conventional oil production}} \times 88.84 \times 10^6 = \underline{23,987 \text{ tons}}$$

$$N_2O : 6.4 \times 10^{-4} \frac{\text{tons}}{1000 \text{ bbl conventional oil production}} \times 88.84 \times 10^6 = \underline{57 \text{ tons}}$$

Total GHG emission min.

$$= (1 \times 5,952,280) + (21 \times 442) + (310 \times 57)$$

$$= \underline{5,979,232 \text{ tons CO}_2 \text{ equivalent}}$$

Total GHG emission max.

$$= (1 \times 5,952,280) + (21 \times 23,987) + (310 \times 57)$$

$$= \underline{6,473,677 \text{ tons CO}_2 \text{ equivalent}}$$

3.3.1.2 Calculation According to Gas Flaring

Formula:

$$CO_2 \text{ Emissions} = \text{Volume Flared} \times \text{Molar volume} \times \sum \left(\frac{\text{mole Hydro carbon}}{\text{mole gas}} \times \frac{X \text{ mole C}}{\text{mole Hydro carbon}} \right) \\ \times \text{Combustion efficiency} \left(\frac{0.98 \text{ mole } CO_2 \text{ formed}}{\text{mole C combusted}} \right) \times MW \text{ } CO_2$$

$$CH_4 = \text{volume flared} \times CH_4 \text{ mole fraction} \times \% \text{ residual } CH_4 \times \text{molar volume} \times MW \text{ } CH_4$$

$$N_2O = \text{volume gas production} \times 2.1 \times 10^{-5}$$

Example: (API Compendium, 2004)

A production facility produces 84,950 m³/day of natural gas. In a given year 566,337 m³ of field gas are flared at the facility. The flare gas composition is unknown.

Assumptions:

Since test results or vendor data are not available, emissions will be calculated based on 98% combustion efficiency for CO₂ emissions and 2% uncombusted CH₄. This is consistent with published flare emission factors, fuel carbon combustion efficiencies, control device performance, and results from the more recent flare studies (API Compendium, 2004).

Calculations:

$$CO_2 : \frac{566,337 \text{ m}^3 \text{ gas}}{\text{yr}} \times \frac{\text{lbmole gas}}{10.74 \text{ m}^3 \text{ gas}} \times \left(\frac{0.80 \text{ lbmole } CH_4}{\text{lbmole gas}} \times \frac{\text{lbmole C}}{\text{lbmole } CH_4} + \frac{0.15 \text{ lbmole } C_2H_6}{\text{lbmole gas}} \times \frac{2 \text{ lbmole C}}{\text{lbmole } C_2H_6} + \frac{0.05 \text{ lbmole } C_3H_8}{\text{lbmole gas}} \times \frac{3 \text{ lbmole C}}{\text{lbmole } C_3H_8} \right) \\ \times \frac{0.98 \text{ lbmole } CO_2 \text{ formed}}{\text{lbmole C combusted}} \times \frac{44 \text{ lb } CO_2}{\text{lbmole } CO_2} \times \frac{\text{ton}}{2204.62 \text{ lb}} \\ = 1,289 \text{ tons } CO_2/\text{yr}$$

$$CH_4 : \frac{566,337 \text{ m}^3 \text{ gas}}{\text{yr}} \times \frac{0.80 \text{ scf } CH_4}{0.02831685 \text{ m}^3 \text{ gas}} \times \frac{0.02 \text{ scf noncombusted } CH_4}{\text{scf } CH_4 \text{ total}} \times \frac{\text{lbmole } CH_4}{379.3 \text{ scf } CH_4} \times \frac{16 \text{ lb } CH_4}{\text{lbmole } CH_4} \\ \times \frac{\text{ton}}{2204.62 \text{ lb}} = 6.1 \text{ tons } CH_4/\text{yr}$$

$$N_2O: \frac{84,950 \text{ m}^3}{\text{day}} \times \frac{365 \text{ days}}{\text{yr}} \times \frac{2.1 \times 10^{-5} \text{ tons } N_2O}{10^6 \text{ m}^3 \text{ gas}} = \underline{6.51 \times 10^{-4} \text{ tons } N_2O/\text{yr}}$$

Total GHG emission

$$= (1 \times 1,289) + (21 \times 6.1) + (310 \times 6.51 \times 10^{-4})$$

$$= \underline{1417.302 \text{ tons } CO_2 \text{ equivalent}}$$

3.3.2 Calculation based on CAPP Guide

Formula:

$$CO_2eq : 2510 \frac{g}{m^3} \times \text{volume flared} \times \frac{1 \text{ ton}}{10^6 \text{ gram}}$$

Example:

A production facility produces 84,950 m³/day of natural gas. In a given year 566,337 m³ of field gas are flared at the facility. The flare gas composition is unknown.

Calculation:

$$CO_2eq : 2510 \frac{g}{m^3} \times 566,337 \text{ m}^3 \times \frac{1 \text{ ton}}{10^6 \text{ gram}} = \underline{1421 \text{ tons } CO_2eq}$$

3.4 Calculation of gas-to-oil ratio (GOR)

Reservoir fluids are broadly categorized using oil and gas gravity and the gas-oil production ratio (GOR), which is the volumetric ratio of the gas produced at standard condition of temperature and pressure (STP) to the oil produced at STP, i.e. 60 degree F (298 K) and one atmosphere (101.3 kPa) (Jahn et al, 2001).

Table 3.6 Characteristics of reservoir fluids

Type of fluids	Dry gas	Wet gas	Gas Condensate	Volatil e Oil	Black Oil
Characteristics	Colourless gas	Colourless gas + some clear liquid	Colourless+ significant clear/straw liquid	Brown liquid, some red or green colour	Black viscous liquid
Initial GOR (m³/m³)	No liquids	> 2672	534 – 2672	445 – 534	18 – 445
Oil gravity, °API	-	60 – 70	50 – 70	40 – 50	<40
Gas specific gravity (air=1)	0.60 – 0.65	0.65 – 0.85	0.65 – 0.85	0.65 – 0.85	0.65 – 0.8
Composition (mol %)					
C₁	96.3	88.7	72.7	66.7	52.6
C₂	3.0	6.0	10.0	9.0	5.0
C₃	0.4	3.0	6.0	6.0	3.5
C₄	0.17	1.3	2.5	3.3	1.8
C₅	0.04	0.6	1.8	2.0	0.8
C₆	0.02	0.2	2.0	2.0	0.9
C₇₊	0.0	0.2	5.0	11.0	27.9

Source: Jahn et al, 2001 with modifications

These types of reservoir fluids are used to predict fluid behaviour during production and how this influences field development planning.

Gas-to-oil ratio (GOR) is used to calculate how much volume of gas at atmospheric pressure is produced per unit of oil produced in cubic feet/barrel. GOR is calculated using known gas and oil volumes at surface conditions. Usually every oil field/well has a different GOR. There are some ways to estimate GOR, either by engineering calculation (such as Vasquez – Beggs formula) or by measuring it in laboratories. It should be noted that Rang Dong methodology does not mention anything about this ratio.

In this study, the calculations of GOR will be done simply by dividing the amount of associated gas by the amount of oil production, both from the first data set of BPMIGAS.

$$GOR = \frac{\text{amount of associated gas, in } m^3}{\text{oil production, in } m^3}$$

The value of GOR will be estimated for each field. However, due to the huge amount of data entries (more than 1400 name of oil fields), the value for each company will

be calculated as well. As usual, the ranking of the GOR values from each field and company will be done based on values in 2003. It should be noted that the lack of data and the questionable data reliability makes it difficult to have a sound estimation. Therefore further research is recommended in order to come up with better data.

4 Oil, Gas and Gas Flaring in Indonesia

As discussed in Chapter 3, data is obtained from several sources (see Table 3.4). Table 4.1 below presents these data sets. Oil production is presented in thousand stock tank barrel (MSTB), while gas and gas flaring are in million standard cubic feet per day (MMSCFD).

Table 4.1 Data of Oil, Gas and Gas Flaring in Indonesia

Year	Oil and Condensate Production (10^6 m^3)	Gas Production (10^6 m^3)	Gas Flaring (10^6 m^3)	% of Gas Flaring to Gas Production
1990	88.846	89,451	4,721	5.28
1991	90.716	69,711	5,747	8.24
1992	86.040	73,132	6,155	8.42
1993	98.159	75,376	5,972	7.92
1994	97.642	84,618	N/A	N/A
1995	101.468	85,858	N/A	N/A
1996	102.241	80,858	4,861	6.01
1997	98.357	81,242	4,103	5.05
1998	96.902	75,978	3,785	4.98
1999	95.487	78,953	3,473	4.40
2000	94.368	73,044	2,813	3.85
2001	83.929	70,738	3,538	5.00
2002	77.990	79,091	3,287	4.16
2003	73.266	88,115	4,123	4.68

Source: BPMIGAS, MIGAS, State Ministry for Environment (1999)

Besides total national production and gas flaring, this study will also discuss the production and gas flaring of companies. The number (and names) of companies each year are varied, due to some inconsistency and lack of data. In addition, BPMIGAS provides data from each field as well. However, it is not clear which field is still in operation, and which is not. Due to the time constraint, it was not possible to recheck this directly with the oil companies. Therefore this study does not aim to analyse

detailed data from those oil fields, but further research in this area is still possible. Further analysis and explanations are discussed in the next sub chapters.

4.1 Oil Production

Production was at its peak in 1996, then slowly went down each year until last year (2003). Continued slow investment and a decrease in new exploration were key factors behind the decline. In addition, old fields and bureaucratic issues are also responsible for Indonesia's declining oil production and delays in numerous development projects.

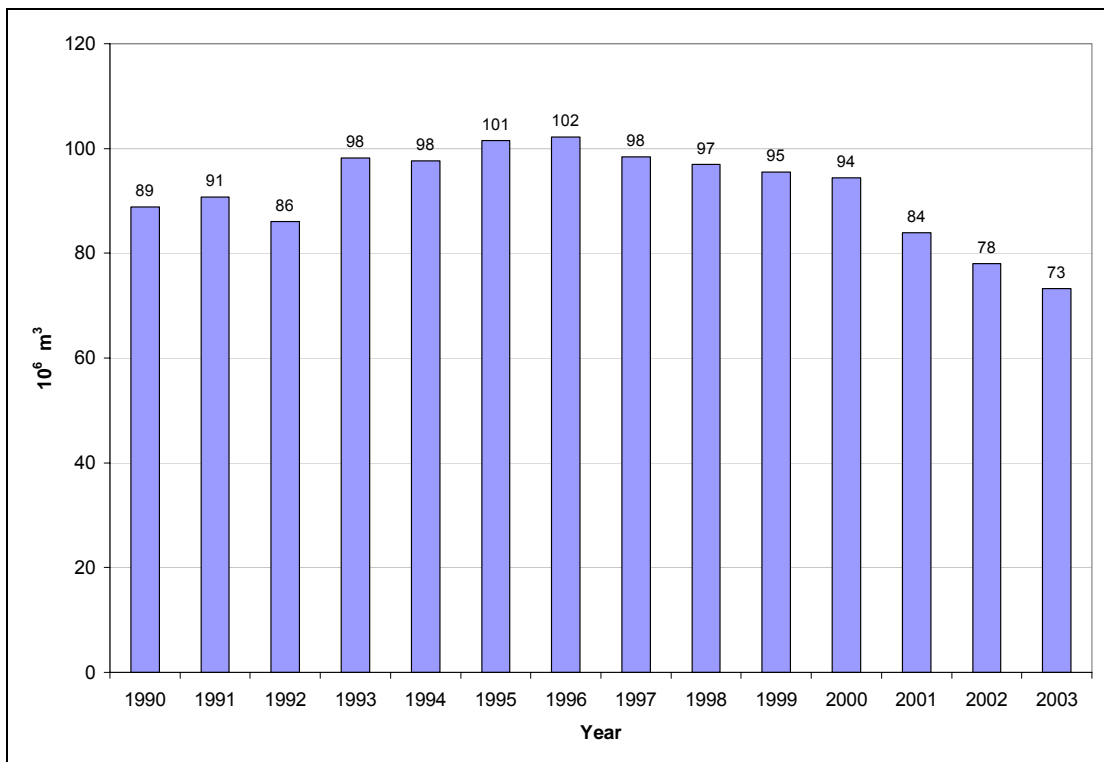

Figure 4.1 Indonesian Oil Production in 1990 – 2003

Source: BPMIGAS

The data from BPMIGAS shows that there are around 130 companies' names. Those names are coded for confidentiality reason, as explained in Chapter 3. Their production is depicted in Figure 4.2, while the numbers are available in Appendix F. It shows that the biggest oil producer in Indonesia is company IC + TD, which has constantly been in the lead since 1990. Other consistent producers are EE, IR, CI, AM and OV.

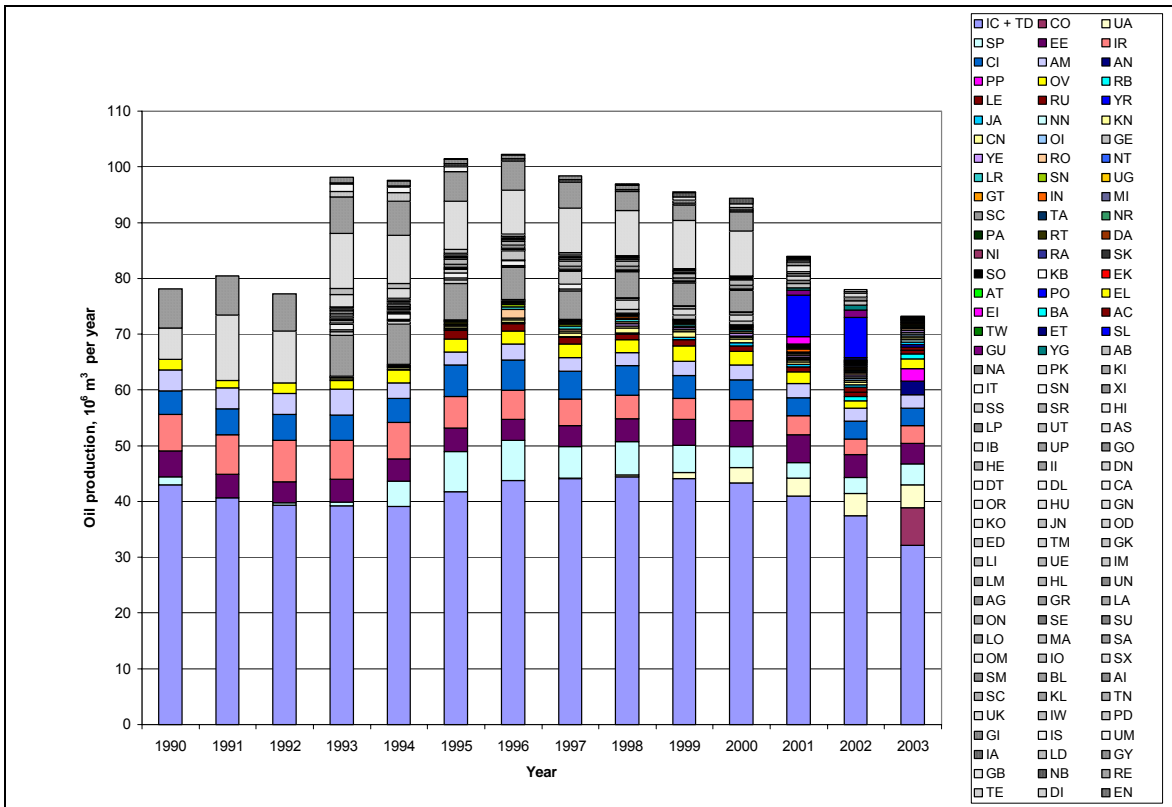

Figure 4.2 Oil Production According to Oil Companies

Source: recalculated from BPMIGAS

To assess the potential of each company, they are ranked according to their production per year. Since some mergers and acquisitions have occurred in the last years, this ranking focuses on the last five years only, i.e. 1999 – 2003. In addition, it is not possible to do the ranking by, for example, average data. Therefore the data is sorted primarily according to figures in 2003, and then followed by number in 2002, and so on. This system is applied to other criteria, i.e. gas production and flaring, as well. This is done in the aim that only existing companies are taken into consideration. However, in some cases it happens that there is no data from the previous years, as shown in Table 4.2. This could be caused by the company being new or bearing a new name since 2003, e.g. CO, AN, PP.

IC + TD is the biggest oil producer for the last five years, even since 1990. Each year, it contributes more than 40% of the country's crude oil production, even though IC + TD's production has dropped since 2002, mostly due to the loss of some fields to the regional government. The second place in 2003 belongs to CO, a new company, which accounts for about 10% of all Indonesian oil production.

Table 4.2 Top Ten of Oil Producers (in million cubic meters)

Company	1999	2000	2001	2002	2003
IC + TD	44.079	43.286	41.002	37.421	32.155
CO					6.673
UA	1.076	2.837	3.196	4.030	4.187
SP	4.895	3.735	2.781	2.808	3.741
EE	4.660	4.669	5.025	4.169	3.626
IR	3.741	3.741	3.356	2.762	3.278
CI	4.122	3.530	3.216	3.208	3.016
AM	2.565	2.687	2.530	2.321	2.519
AN					2.436
PP					2.209
OV	2.785	2.433	2.115	1.286	1.766
Others	27.565	27.452	20.709	19.983	7.659
Indonesia	95.487	94.368	83.929	77.990	73.266

Source: recalculated from BPMIGAS

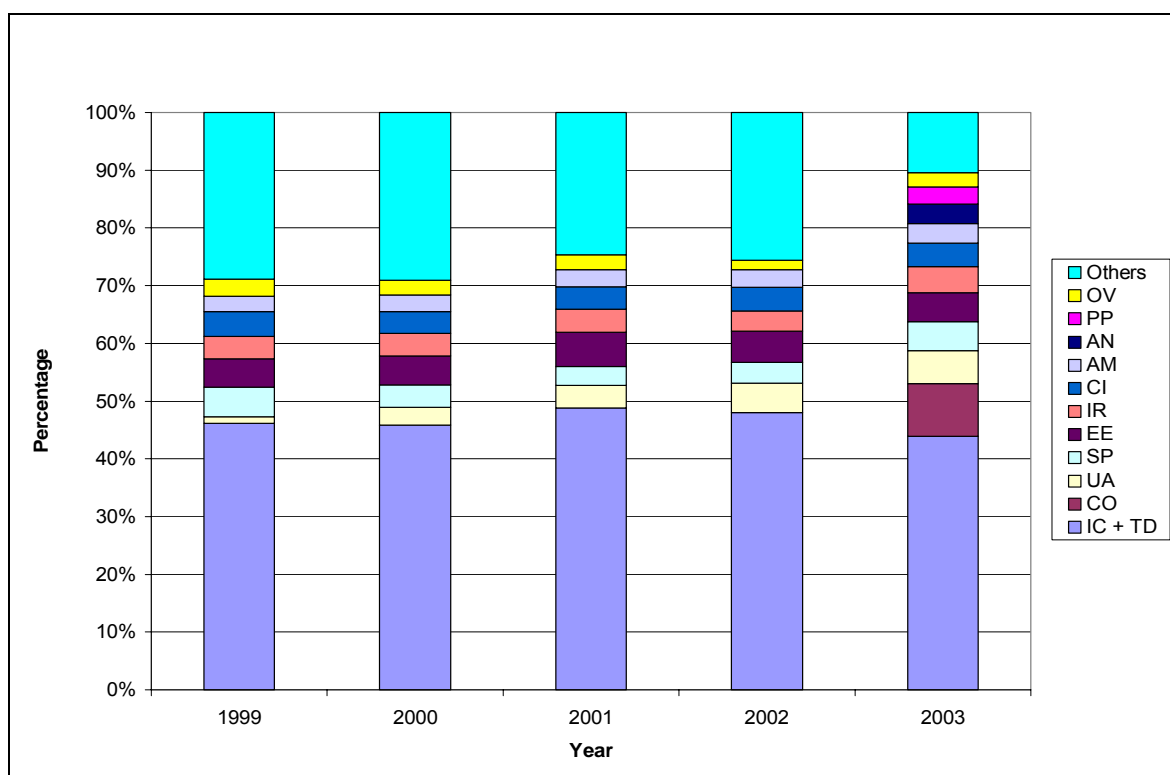

Figure 4.3 The Big Ten of Oil Producers

Source: recalculated from BPMIGAS

For the projection, this study refers to data provided by EIA in its International Energy Outlook 2004. It is projected that the world oil production will almost double from 1990 to 2025. However, Indonesian production is stable, even shows a tendency of a decline. A prediction from the US Embassy forecasts that Indonesia's oil production will

continue to decline, even if there is new investment. The new fields' projects need several years to begin their production, while most existing oil fields in Indonesia are aging. This means that production will continue to drop without greater investment in oil recovery.

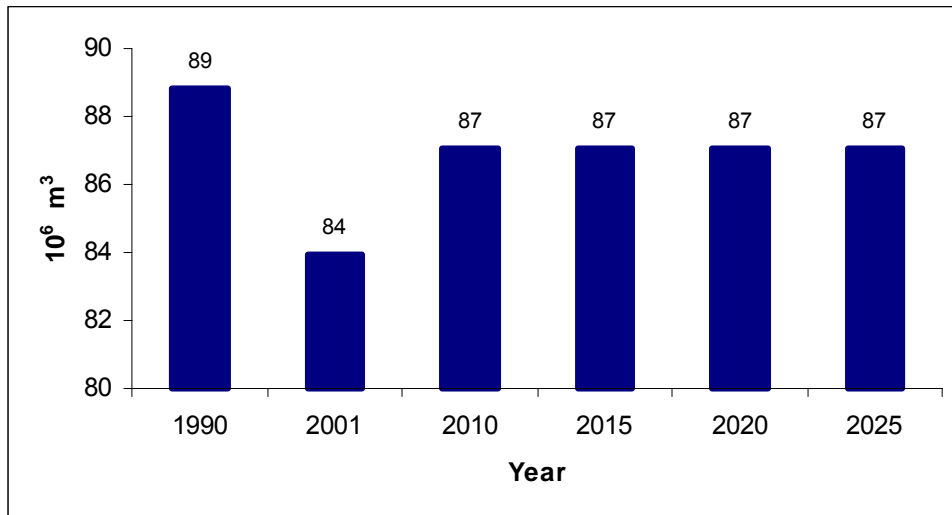

Figure 4.4 Historical and Projected Oil Productions

Source: recalculated from BPMIGAS and EIA, 2004

Indonesia's major crude oil customers (in rank order) were Japan, South Korea, Australia, Singapore, China and the United States. Historical data shows that Indonesia's overseas markets generally showed a decline in sales. This is projected to continue happening. As shown in Figure 4.5, Indonesia contributes less and less to the total world production.

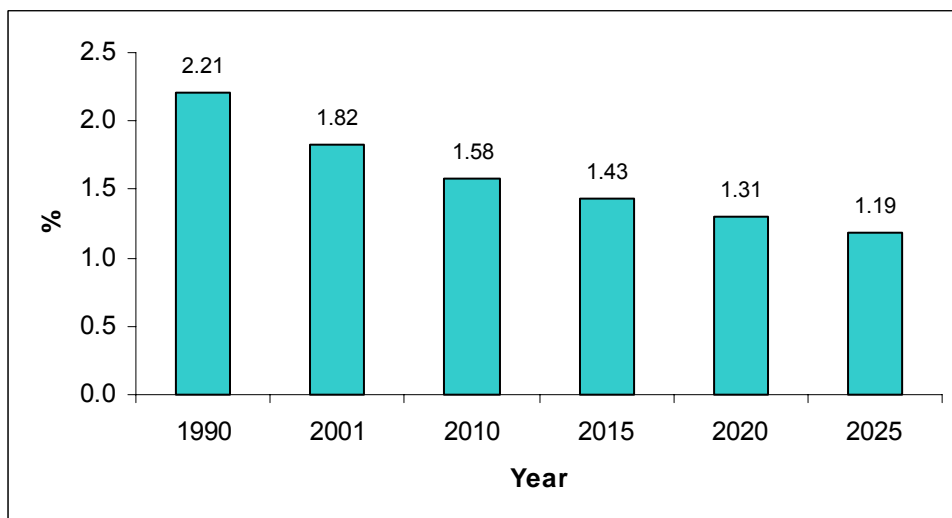

Figure 4.5 Contribution of Indonesia to World Oil Production

Source: recalculated from EIA, 2004

4.2 Gas Production

Indonesia is the sixth largest gas producer in the world. Due to more competitive LNG markets and increasing domestic gas demand, Indonesia's natural gas industry is changing. The fuel subsidy removals and gas incentives of the Oil and Gas Law 2001 caused the use of gas to increase domestically, as well as increasing power demands.

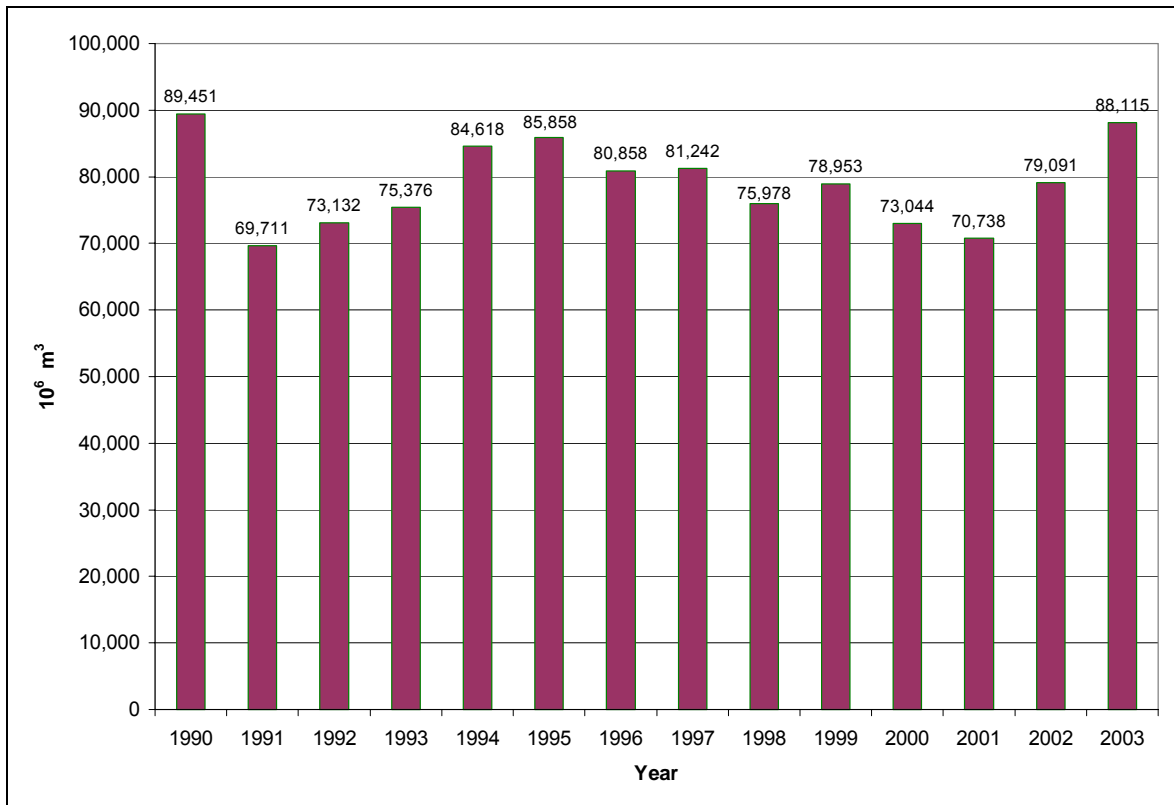

Figure 4.6 Indonesian Gas Productions in 1990 – 2003

Source: BPMIGAS

The main gas productions are located in East Kalimantan and Natuna Island. There are about 60 companies producing gas (see Figure 4.7).

The industry is dominated by about 12 major companies, which account for 90 percent of all production. Most of them produce a large amount constantly (see EE, LB, OV) while the others are new (or were acquired and have new names) MS, BN, GJ. Actually AM is an 'old' player; however its data from previous years is not available. This is presumably due to the new institutional system applied in this company.

Even before 1996, EE continuously became the largest gas producer in Indonesia, while OV is accounted for the third and LB for the second largest producer since 2000.

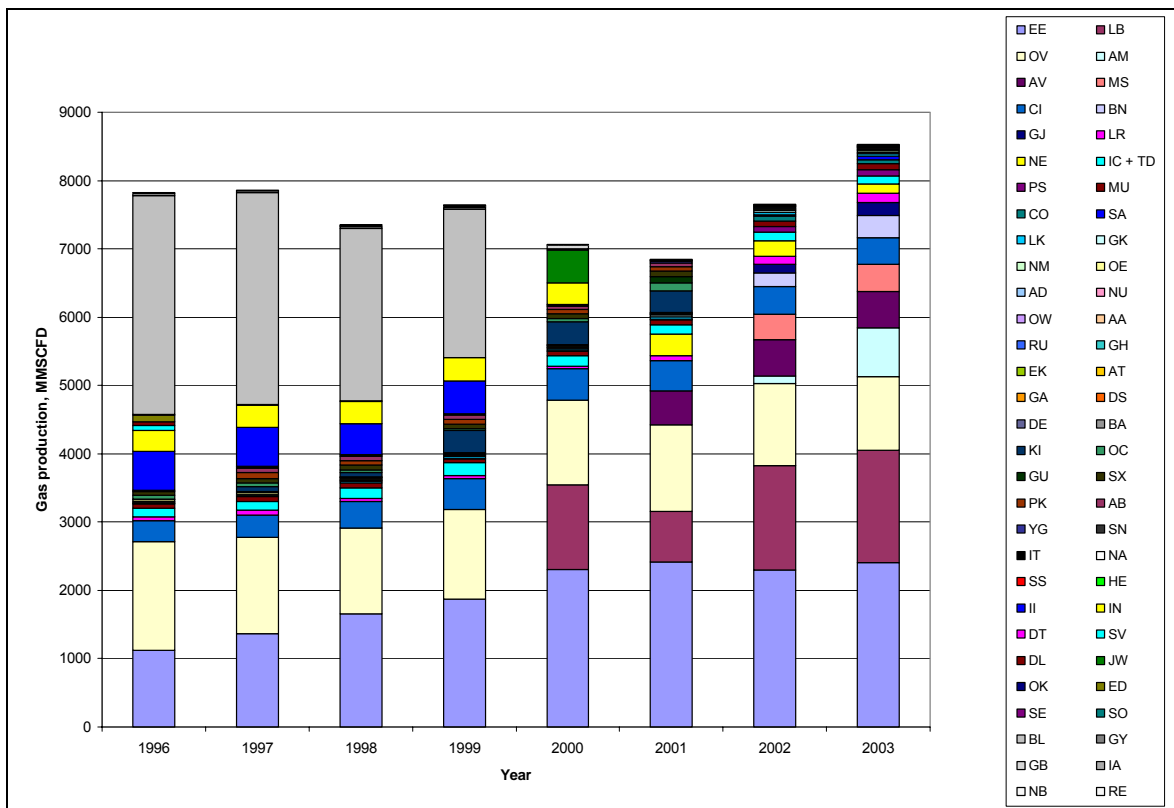

Figure 4.7 Companies' Gas Production

Source: recalculated from BPMIGAS

Table 4.3 Big Gas Producers (in million cubic meters)

Company	1999	2000	2001	2002	2003
EE	19,385	23,879	25,001	23,728	24,849
LB		12,729	7,592	15,797	17,037
OV	13,518	12,806	13,147	12,427	11,118
AM				1,159	7,356
AV			5,151	5,497	5,524
MS				3,805	4,157
CI	4,689	4,776	4,511	4,231	4,018
BN				2,064	3,325
GJ				1,353	1,958
LR	466	361	828	1,172	1,452
NE			3,202	2,359	1,422
IC + TD	1,933	1,646	1,419	1,289	1,151
Others	38,964	16,847	9,888	4,210	4,748
Indonesia	78,953	73,044	70,738	79,091	88,115

Source: recalculated from BPMIGAS

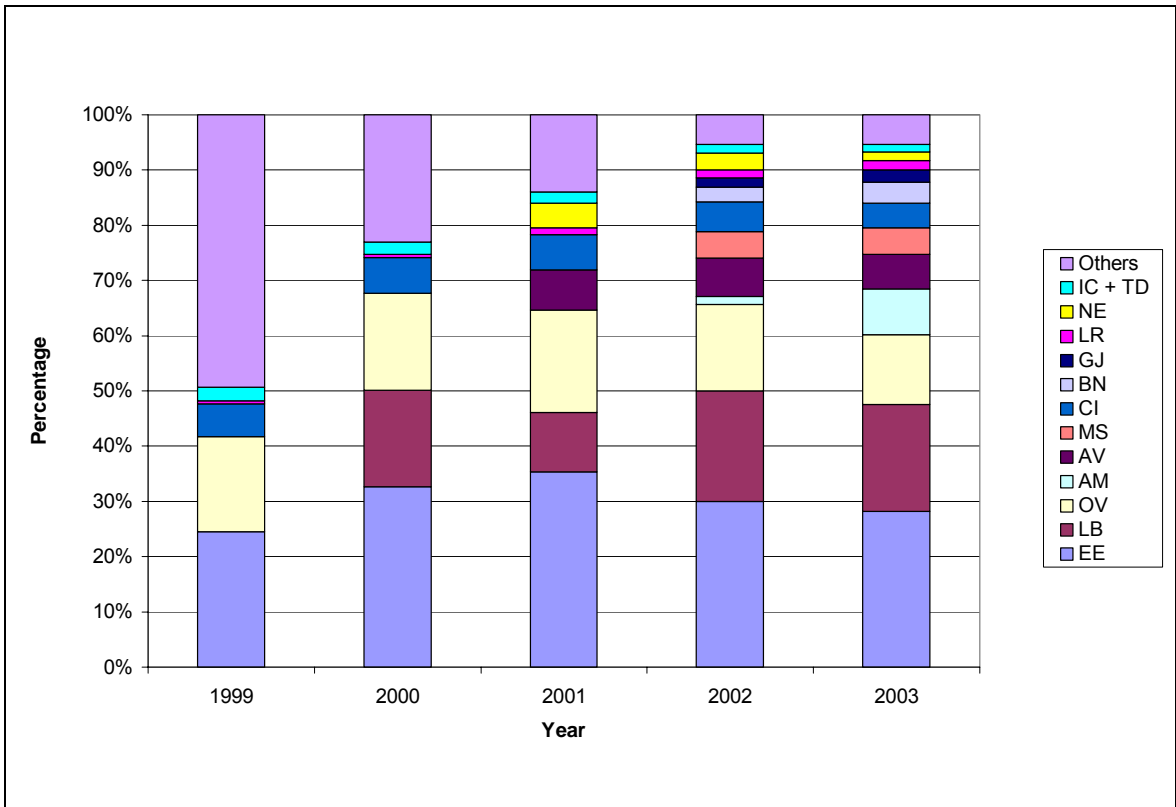

Figure 4.8 The Big Ten of Gas Producers

Source: recalculated from BPMIGAS

It is projected that Indonesian gas production will be developed due to large demand and market growth. However, some regulations need to be established to simplify the gas system and industry in Indonesia, as well as to regulate more incentives of production and domestic gas usage.

4.3 Gas Flaring

To drive a long-term trend, it is useful to estimate how Indonesian flaring progressed from 1990. As mentioned before, data from 1994 and 1995 is unavailable. Figure 4.9 shows the amount of gas flaring in other years. It should be noted that since 1996, the oil production has been decreasing (see sub chapter 4.1). Theoretically, higher oil production will generate more associated gas and, in most cases, increase its flaring. This is also true for flaring from 1996 until 2000, however, flaring amounts in the last three years, namely from 2001 until 2003, are increasing. It is strongly presumed that the new wells, even though they are small in number, do a lot of flaring. However, due

to inadequate data and proof, this assumption needs further confirmation from oil companies themselves.

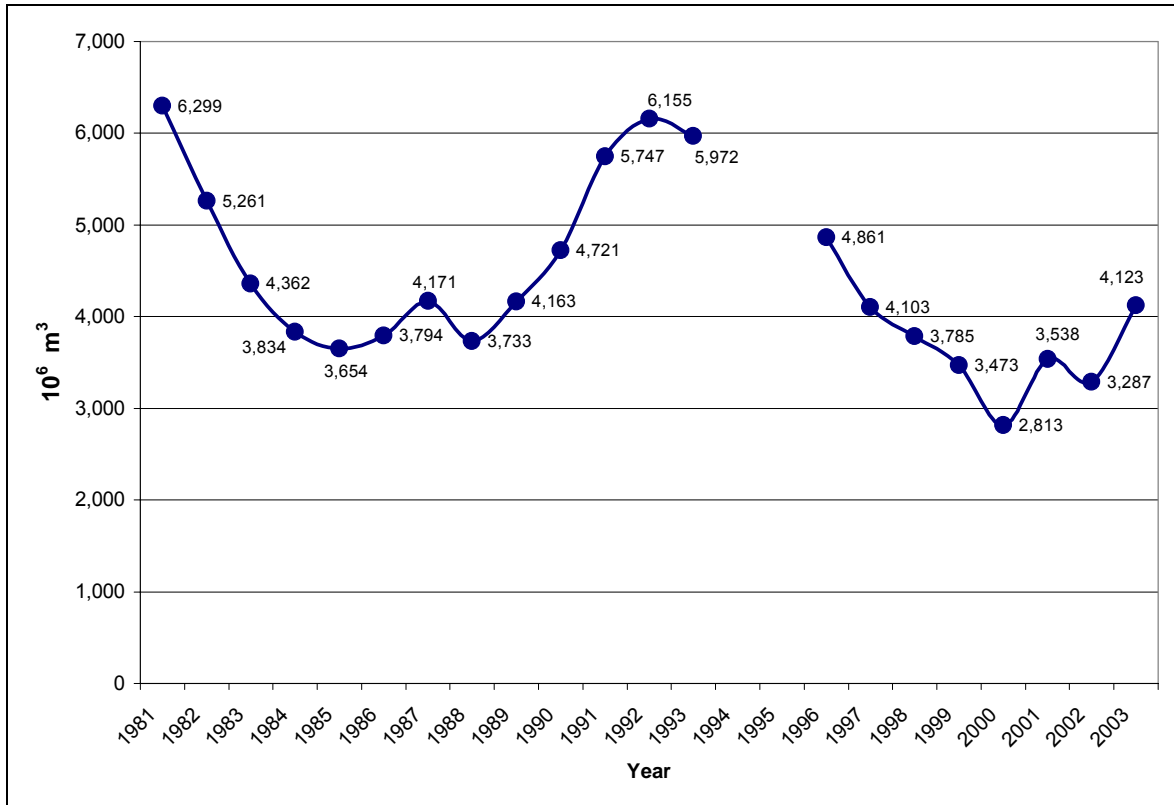

Figure 4.9 Gas Flaring in Indonesia, 1981 – 2003

Source: BPMIGAS

There is a need to make a comparison and confirmation of data from oil companies and analyse the reasons behind the numbers shown in each year. In addition, it is not impossible that some under-reporting occurred, making the accuracy of data questionable.

Over the last 20 years, gas flaring as a share of total gas produced has been reduced by a factor of 4, most of which happened in the early 1980s. Since the mid 1990s the situation has remained stable.

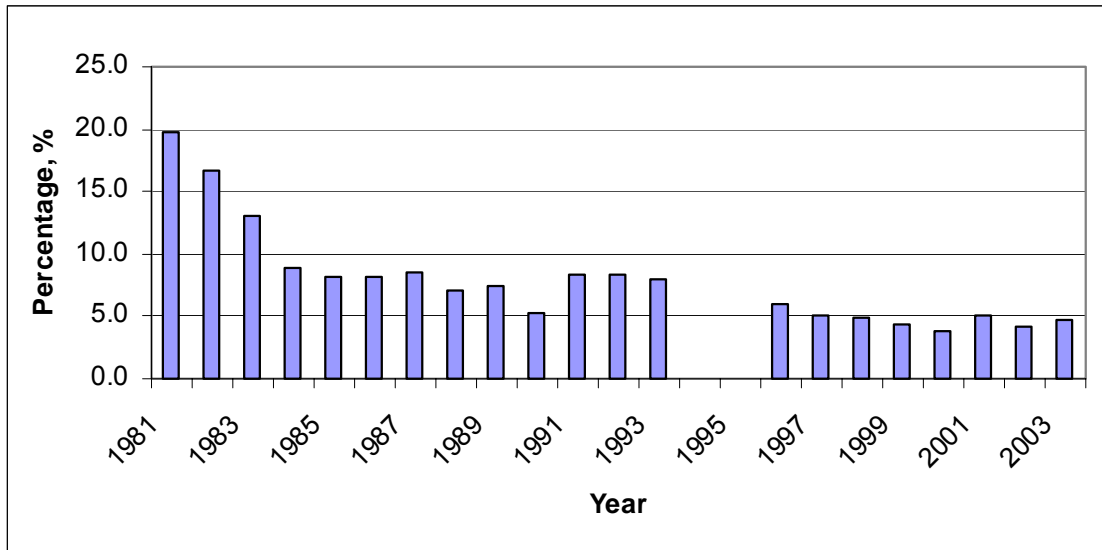

Figure 4.10 Percentage of Gas Flaring in Indonesia, 1981 – 2003

Source: recalculated from BPMIGAS

The flaring amount from each company is shown in Figure 4.11. Around 60 companies are illustrated, but as occurred in previous data of oil and gas production, in some cases inconsistency in data occurred. Each year, some companies merged or were acquired, and names were changed. It also happened that some companies, even though they remained unchanged, do not appear in the list due to lack of data. As observed, it can be distinguished that AM has data on the last two years only (2002 and 2003). Being the biggest flaring emitter for those two years, it is possible that AM also had a significant amount of flaring in previous years. Therefore it is required to obtain more complete and accurate data on the companies to make a thorough analysis.

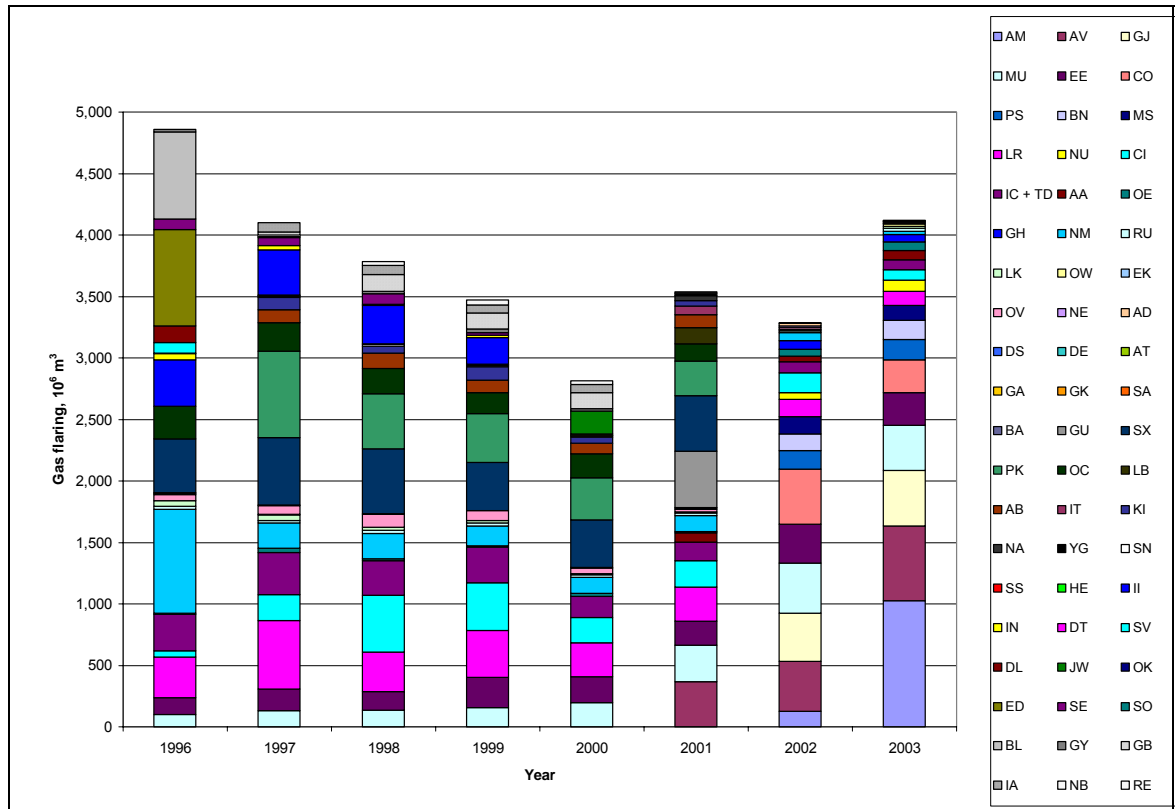

Figure 4.11 Gas Flaring According to Oil Companies

Source: recalculated from BPMIGAS

Generally the amount of associated gas (AG) will be proportional to oil production. It is also possible to reinject AG or use it for energy needs. However, it was impossible to collect the detailed data of AG usage during this study.

Table 4.4 Top Ten of Gas Flaring Emitters (in MMSCFD)

Company	1999	2000	2001	2002	2003
AM	NA	NA	NA	126.694	1,024.738
AV	NA	NA	368.280	404.661	610.434
GJ	NA	NA	NA	391.091	449.198
MU	154.704	193.483	296.695	411.204	370.006
EE	248.521	215.168	196.470	314.441	264.303
CO	NA	NA	NA	447.007	264.014
PS	NA	NA	NA	149.474	169.060
BN	NA	NA	NA	136.679	152.523
MS	NA	NA	NA	141.764	123.201
LR	380.641	275.910	272.675	140.131	115.387
Others	2,689.109	2,128.679	2,403.638	624.170	580.223
Indonesia	3,472.975	2,813.240	3,537.759	3,287.316	4,123.087

Source: recalculated from BPMIGAS

Comparing major oil producers (Table 4.2) with those that flare gas (Table 4.4); it shows that only three big oil producers, namely CO, EE and AM do a lot of flaring. The biggest, IC + TD, is not even one of the big flaring emitters. AM (number eight for oil production) flares the most, while CO, the second biggest oil producer, is ranked as the sixth flaring emitter and EE is number five for both criteria. Some articles in IC + TD's website report their efforts in their locations all over the world to reduce (or eliminate flaring), started by conducting and providing a sound data of their flaring. There is no detailed explanation about what they do in Indonesia concerning this issue, but it might explain their low amounts of flaring in that country.

Comparing the flaring amount in Table 4.4 with big gas producers in Table 4.3, seven names appear on both lists: EE, AM, AV, MS, BN, GJ and LR. Their flaring ranges from 1% (EE) to 23% of total gas production (GJ). For other big producers, they either do not flare a lot (presumably this is the case for IC + TD), or the flare is under-reported.

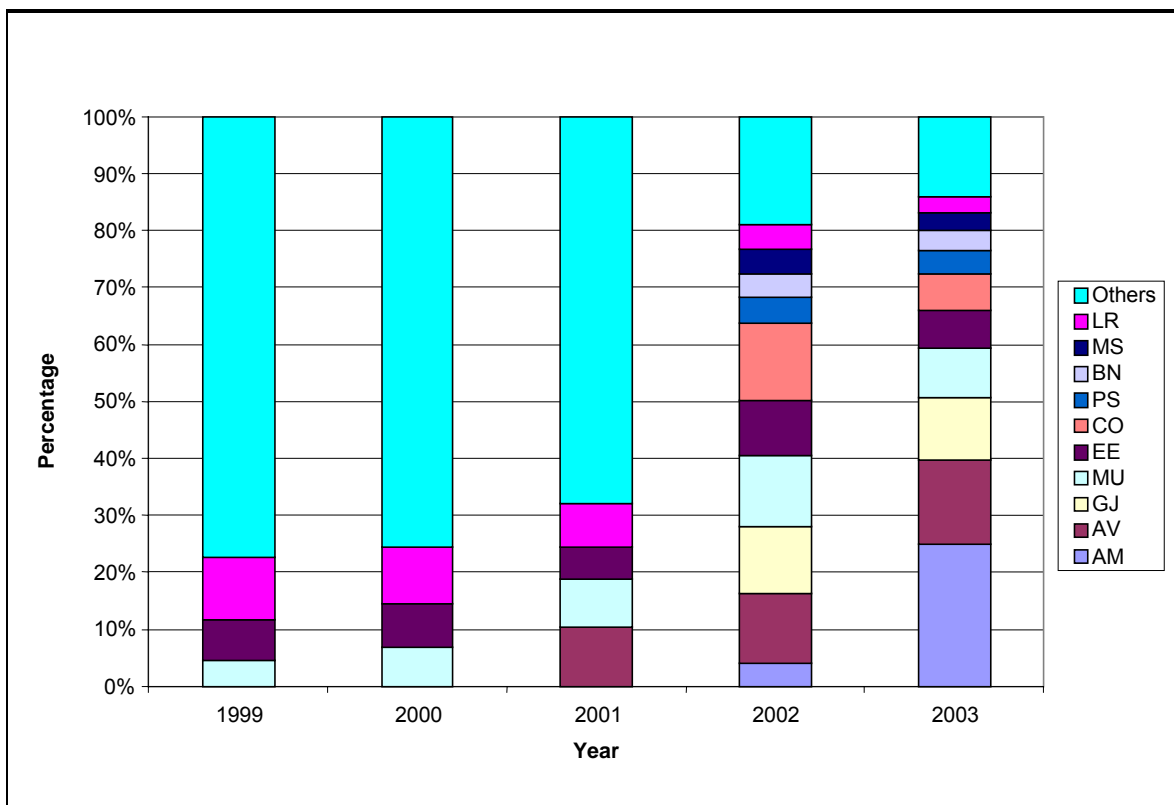

Figure 4.12 The Big Ten of Gas Flaring Emitters

Source: recalculated from BPMIGAS

Figure 4.12 present companies with the highest of flaring. In 2003, AM contributed almost 25% of total flaring, while it flared less than 5% in the previous year. AV has gradually increased its flaring amount for the last three years, ranging from 10% to 15%. Others companies, MU, EE and LR, each contribute from 3% (LR in 2003) to 14% (EE in 2002). All these companies contributed up to 85% of national flaring in 2003, increased from the 81% in 2002.

5 Greenhouse Gas Emissions and Gas-to-Oil Ratio

5.1 GHG Emissions from Gas Flaring in Indonesia

There are some alternative ways to estimate greenhouse gas emissions from gas flaring. In this study, four alternatives are used. The calculations start from the year 1990 and are based on API Compendium (2004) and the guide from Canadian Association of Petroleum Producers or CAPP (2003). According to API Compendium, calculations can be estimated either from the flaring amount or the oil (and condensate) production. Besides these three alternatives of calculation, another alternative is to use the HG emissions numbers published by EIA (2003a).

In choosing the selected alternative, the following is taken into account:

- Alternative 1 from EIA is basically used as a comparison and complementary data
- The calculation based on oil + condensate production, i.e. alternative 2, is around 50% less than the ones based on flaring
- The calculations according to flaring amount based on the Compendium (alternative 3) and CAPP (alternative 4) show, more or less, the same result. However, the one from API is a recommended guide by the World Bank's GGFR

In the end, the chosen alternative is the one according to flaring and based on API Compendium (Alternative 3). To obtain data for 1994 and 1995, which is not possible to calculate due to lack of flaring data, the GHG emissions are extrapolated. All alternatives, including the selected one, are presented in Table 5.1 while the selected numbers are depicted in Figure 5.1.

Figure 5.1 shows the greenhouse gas emissions from flaring in Indonesia from 1990 until 2003. Since it correlates with the flaring amount, it has the same fluctuation with the one of flaring (see data for 1990 – 2003 in Figure 4.9). Almost 12 million tons of CO₂ equivalent were emitted in 1990. In 1992 the emission level increased and reached its peak in 1992 with more than 15 million tons CO₂ equivalent, while after that year a decline is observed.

In addition, during the last three years, 2001 – 2003, higher greenhouse gases were emitted even though oil production is decreasing. This might be due to high emissions from new wells. However, this needs a further confirmation from oil companies themselves.

Table 5.1 GHG Emissions from Gas Flaring in Indonesia (tons of CO₂ eq.)

Year	Alternative 1	Alternative 2	Alternative 3	Alternative 4	Selected
1990	9,044,653	6,501,353	11,819,604	11,850,525	11,819,604
1991	9,694,568	6,638,224	14,386,810	14,424,701	14,386,810
1992	11,773,160	6,296,047	15,409,644	15,450,238	15,409,644
1993	12,413,769	7,182,845	14,949,800	14,989,155	14,949,800
1994	9,476,561	7,144,996	N/A	N/A	Estimated
1995	9,476,561	7,424,967	N/A	N/A	Estimated
1996	9,476,293	7,481,581	12,169,786	12,201,696	12,169,786
1997	9,286,767	7,197,321	10,271,321	10,298,169	10,271,321
1998	9,476,293	7,090,855	9,475,082	9,499,841	9,475,082
1999	9,116,194	7,004,956	8,694,497	10,506,694	8,694,497
2000	8,528,664	6,914,102	7,042,928	8,846,377	7,042,928
2001	9,097,241	6,127,505	8,856,619	11,259,025	8,856,619
2002	8,718,189	5,708,192	8,229,733	8,251,153	8,229,733
2003	N/A	5,176,958	10,322,000	10,348,938	10,322,000

Note: *Alternative 1: From EIA (2003a)*

Alternative 2: Based on API Compendium, according to oil+condensate production

Alternative 3: Based on API Compendium, according to gas flaring amount

Alternative 4: Based on CAPP, according to gas flaring amount

Since there is no data for 1994 and 1995, it is estimated using emission trends from before and after those years. In 1994, 14,023,123 tons of CO₂ eq and in 1995 13,096,457 tons of CO₂ eq are estimated. Those approximations are shown in Figure 5.1 (shaded columns).

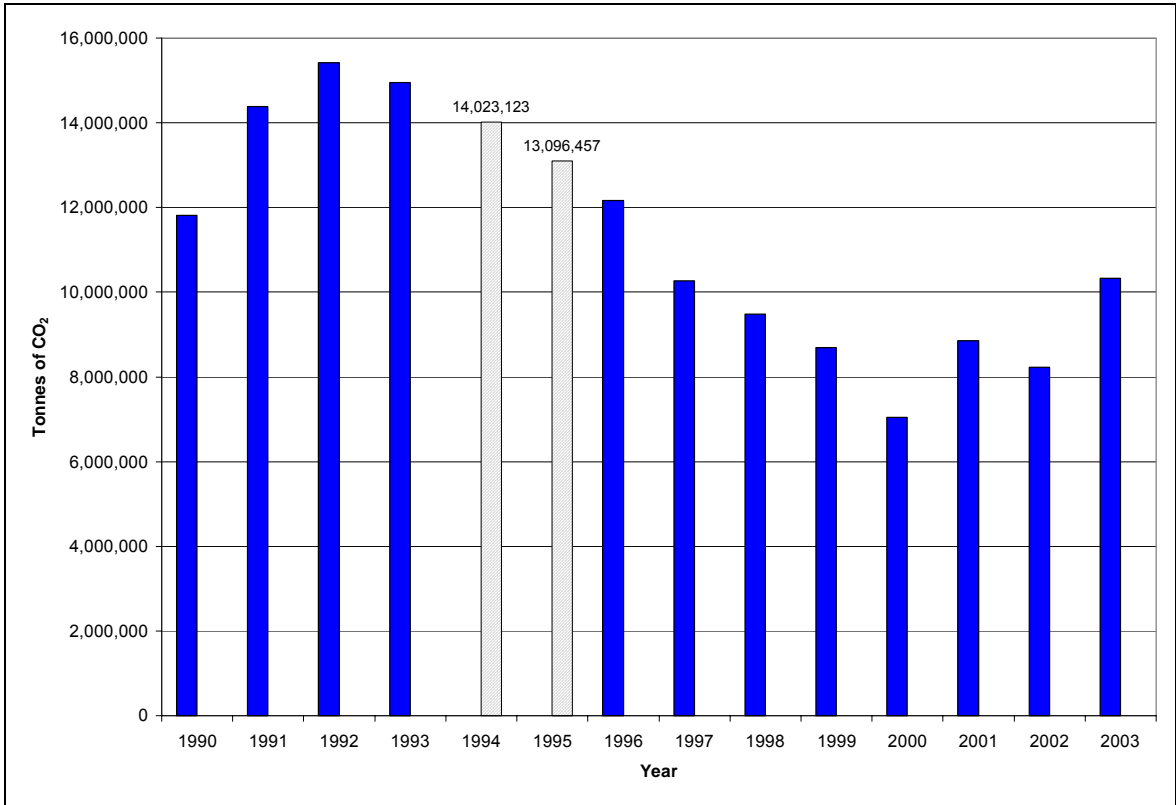

Figure 5.1 GHG Emissions from Gas Flaring in Indonesia

Source: calculation based on API Compendium; own estimation

To compare GHG emission in Indonesia with the ones of Asia and in the world, a set of data from 1990 until 2002 is presented in Table 5.2.

Table 5.2 World Carbon Dioxide Emissions from Flaring (Million Metric Tons of CO₂)

Year	Indonesia	Asia & Oceania	World
1990	11.82	26.05	178.73
1991	14.39	25.61	248.32
1992	15.41	25.18	216.37
1993	14.95	22.60	220.20
1994	14.02	19.05	221.74
1995	13.10	15.64	220.34
1996	12.17	15.06	234.78
1997	10.27	14.81	209.71
1998	9.48	15.17	206.95
1999	8.69	15.30	194.57
2000	7.04	14.44	188.88
2001	8.86	11.93	159.18
2002	8.23	11.39	147.73

Source: EIA, 2004c; calculations based on API Compendium, 2004

Indonesia's yearly contribution to Asian and total world greenhouse gas emissions can be seen in Figure 5.2 and Figure 5.3. The maximum world emissions occurred in 1991 (248 million tons), when at the same time Asia remained the same (26 million) and Indonesia emitted quite a high amount of greenhouse gases (14 million). The world trend has a tendency of declining starting in 1996, while Asia started to decrease in 2000 and Indonesia had a lower amount in 2000 (around 7 million), but increased again in the following years.

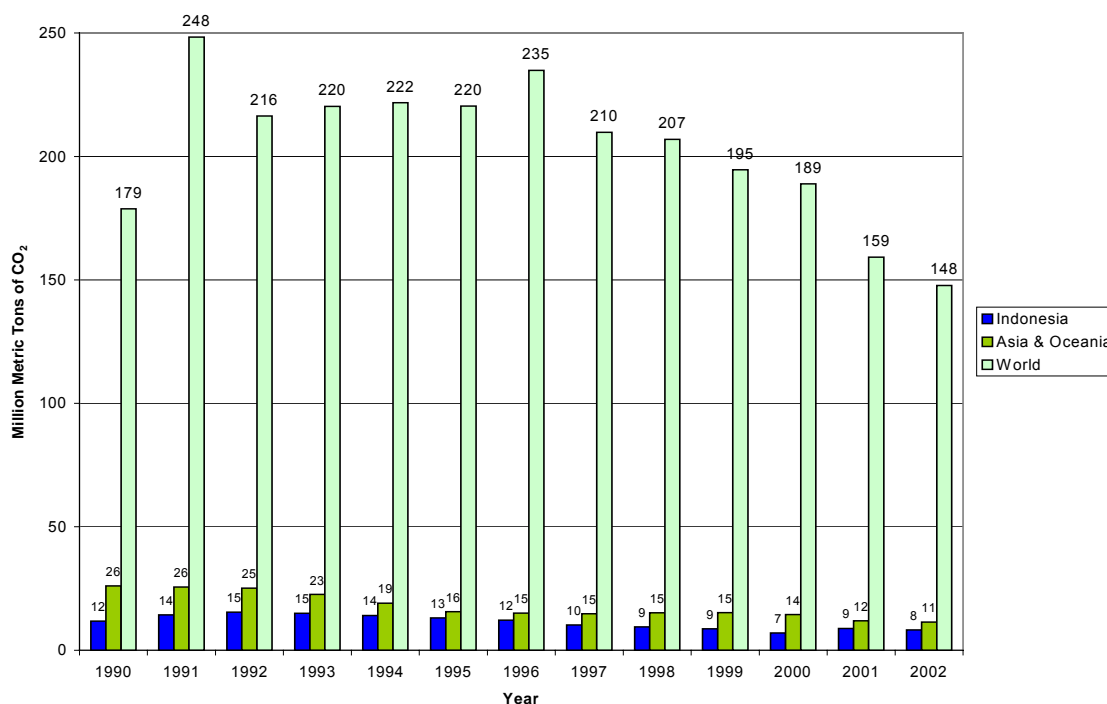

Figure 5.2 GHG Emissions from Flaring

Source: recalculated from BPMIGAS and EIA, 2004c

Figure 5.3 shows the percentage of Indonesian contributions to Asian and world emissions from flaring. It accounts for an average of 6% of the total world GHG, while Asia in general contributes more than 8%. However, Indonesia contributes more than 70% of Asian greenhouse gas emissions from flaring. Being the seventeenth largest oil producer in the world with 1.8% of total world production and ranked number two in Asia after China, with its large GHG emissions this might mean that Indonesia has a better opportunity to have CDM in flaring reduction than other countries in Asia. A rough estimation in Figure 5.4 shows who the big GHG emitters from flaring in Asia are. Please note that discrepancies may occur due to rounding.

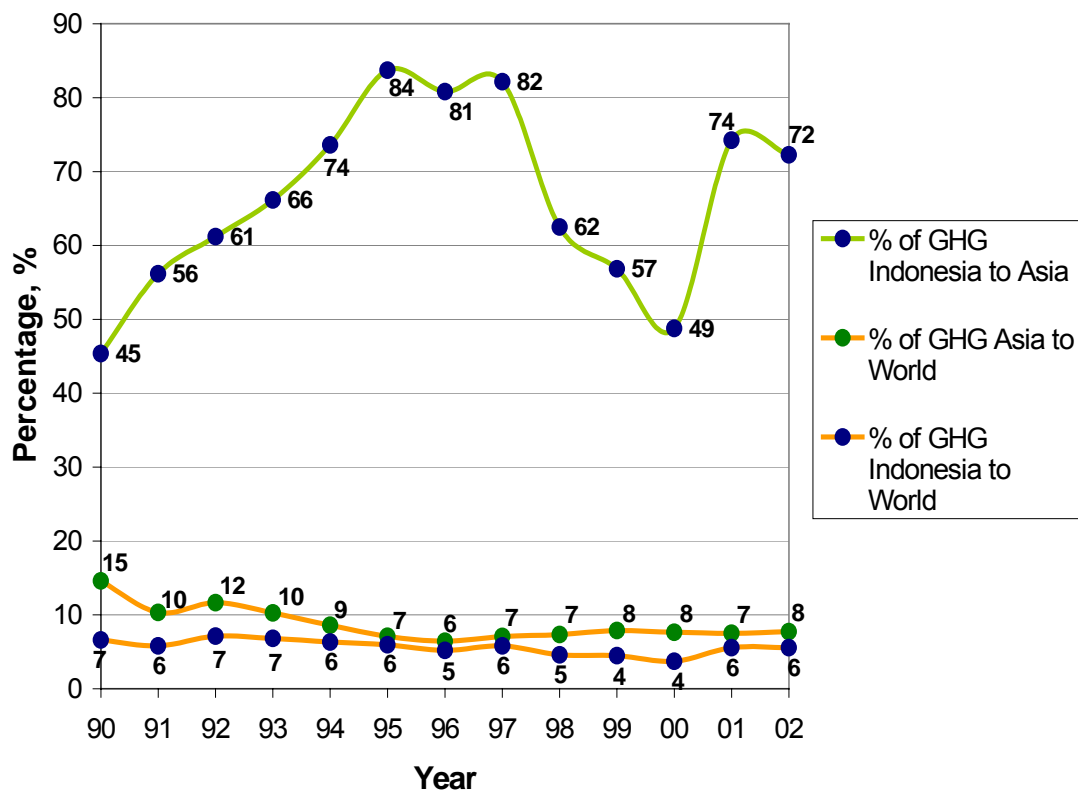

Figure 5.3 Share of Indonesia and Asia to the World’s GHG Emissions

Source: own calculation based on data from BPMIGAS and EIA, 2004c

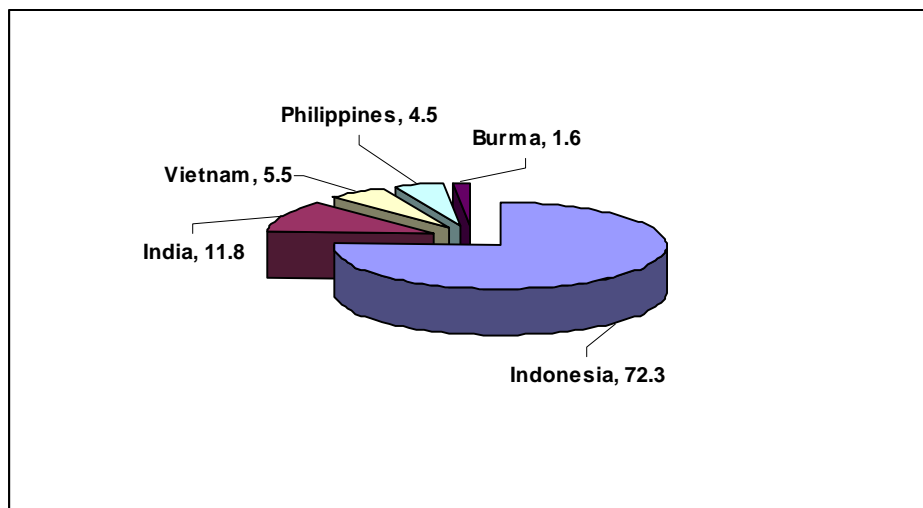

Figure 5.4 Share some countries’ share into Asia’s GHG Emission from Gas Flaring in 2002 (in %, discrepancies may occur due to rounding)

Source: own calculation based on data from BPMIGAS and EIA, 2004c

In 2001, the Indonesian Ministry of Environment published a study on CDM potential in Indonesia. It contains historical data (from 1990 until 1994) and projected data on

greenhouse gas emissions as shown in Table 5.3. These total national emissions are collected from energy, industry, forest and land, and agriculture sectors. Due to lack of data, this study still uses the NSS' forecast for the years of 1995 – 2000 and there is no data for 2001 – 2003.

Table 5.3 Total GHG emission in Indonesia

Year	Total GHG Emissions (tons of CO₂ eq.)	GHG from Flaring (tons of CO₂ eq.)	% to total GHG emission
1990	450,279,000	11,819,604	2.62
1991	547,082,000	14,386,810	2.63
1992	498,278,000	15,409,644	3.09
1993	359,436,000	14,949,800	4.16
1994	479,202,000	14,023,123	2.93
1995	521,428,571	13,096,457	2.51
1996	N/A	12,169,786	N/A
1997	N/A	10,271,321	N/A
1998	N/A	9,475,082	N/A
1999	N/A	8,694,497	N/A
2000	471,428,571	7,042,928	1.49
2001	N/A	8,856,619	N/A
2002	N/A	8,229,733	N/A
2003	N/A	10,322,000	N/A
2005	485,714,286	N/A	N/A
2010	550,000,000	N/A	N/A
2015	642,857,143	N/A	N/A
2020	785,714,286	N/A	N/A

Source: NSS, 2001; own calculations

Between 1990 and 1994 emission rose by 1.8% per year. Figure 5.4 shows that in 1991, Indonesia reached its highest emission level of 550 million tons. After 1995, it slightly decreased from 520 to 470 million tons in 2000, but then mounted up again with a forecasted growth of 2% each year.

Comparing greenhouse gas emission from flaring with total Indonesian GHG emissions shows that flaring contributed around 2 – 4% of total emission (see Figure 5.5). There was a decline during 1995 and 2000; however the total emissions from these years are only projections, which need to be updated with the real conditions.

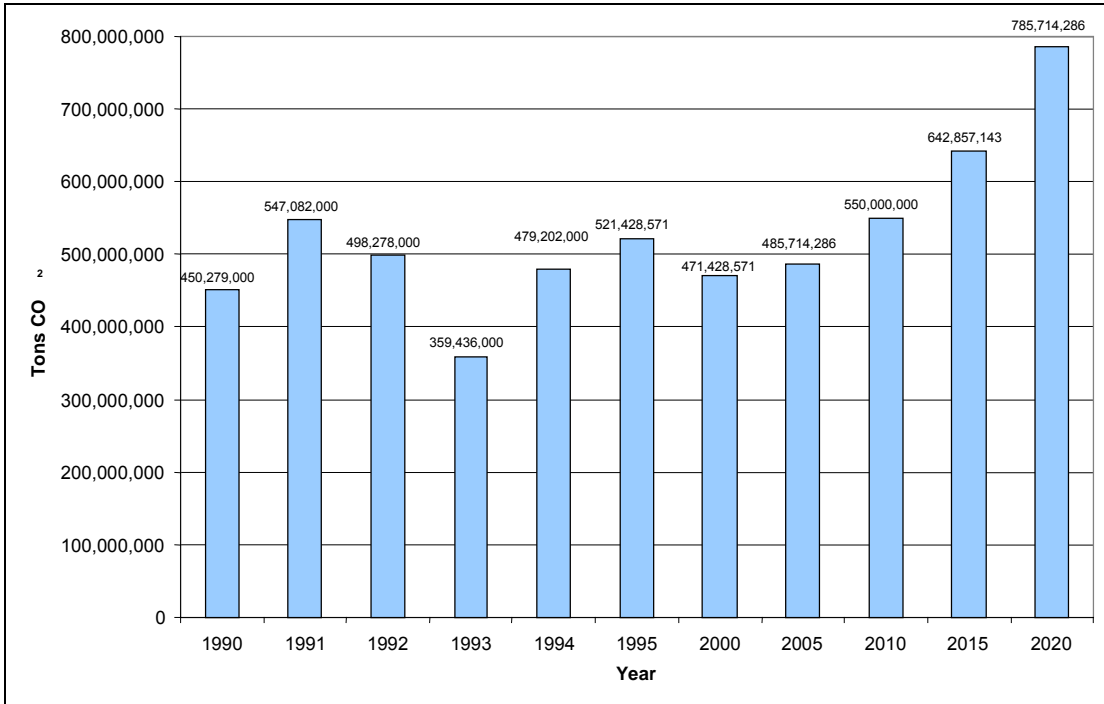

Figure 5.4 Total GHG Emissions in Indonesia

Source: NSS, 2001

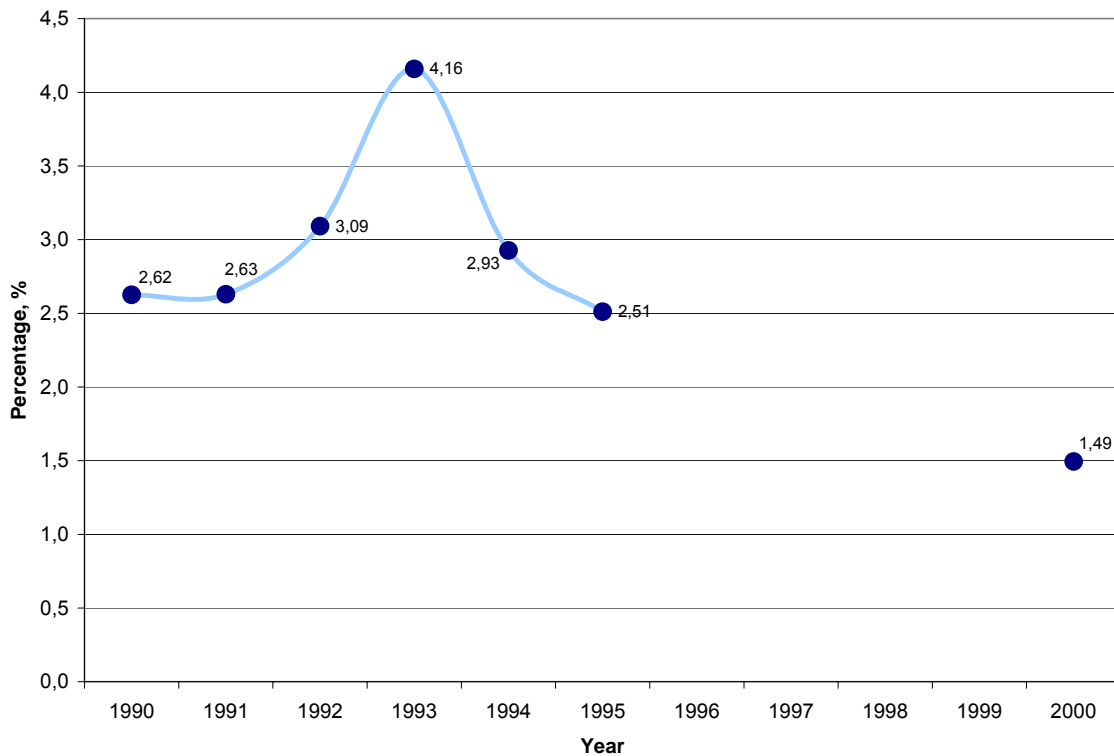

Figure 5.5 Share of Flaring in Total GHG Emissions from Indonesia

Source: own calculation

Because flaring data is used to estimate GHG emissions, it correlates directly with the latter.

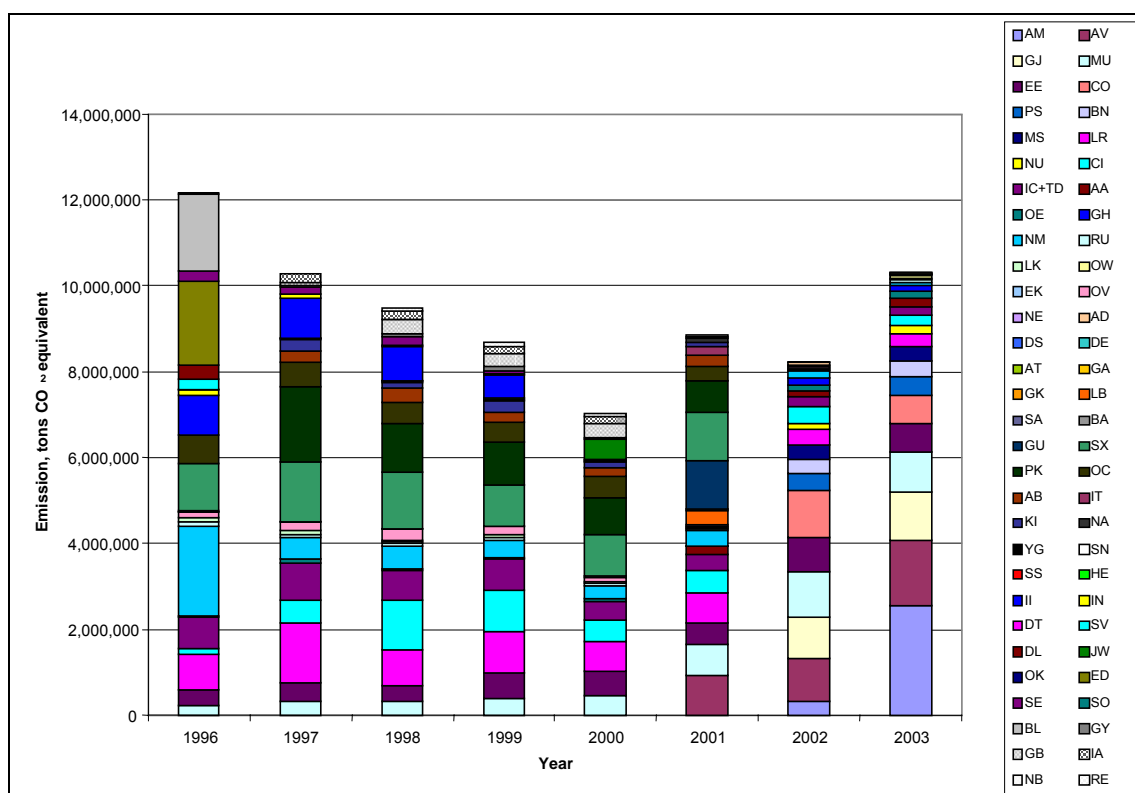

Figure 5.6 GHG Emissions from Flaring According to Oil Companies

Source: own calculation based on API Compendium

The companies who emit high greenhouse gas are the same ones that do a lot of flaring (Table 5.4). In Figure 5.6, AM emitted the highest amount of greenhouse gas in 2003, but its other records are only available for 2002. The available data shows a high increase, as in 2002, 300 thousand tons were emitted, while in 2003 2.5 million tons were emitted, i.e. an increase of more than 800%. This could be due to under-reported data in previous years. This assumption is supported by fact that there is no data for AM before 2002.

As explained in previous chapters, companies' mergers and acquisitions make it difficult to have constant data, i.e. reliable data with exact numbers and names. Figure 5.7 shows that although AM contributes more than 20% of greenhouse gas emission in Indonesia, this is based on data from only two years. The same applies to AV (emitter number two in 2003) and GJ (number three). Others, MU, EE and LR, have been consistently among the big emitters during the last five years. In 2003, these 10 big emitters accounted for more than 80% of total GHG emission in Indonesia.

Table 5.4 Top 10 of GHG Emitters (in tons of CO₂ eq)

Company	1999	2000	2001	2002	2003
AM				317,165	2,565,301
AV			921,958	1,013,035	1,528,150
GJ				979,036	1,124,501
MU	387,279	484,356	742,730	1,029,383	926,251
EE	622,253	538,789	491,991	787,303	661,798
CO				1,119,008	660,917
PS				374,188	423,219
BN				342,164	381,837
MS				354,905	308,439
LR	952,872	690,695	682,600	350,800	288,861
NU				143,055	220,236
CI	965,888	516,647	538,922	399,566	214,517
IC+TD	732,388	423,198	379,082	220,062	207,591
Others	5,033,817	4,389,243	5,099,337	800,062	810,382
Indonesia	8,694,497	7,042,928	8,856,619	8,229,733	10,322,000

Source: own calculations

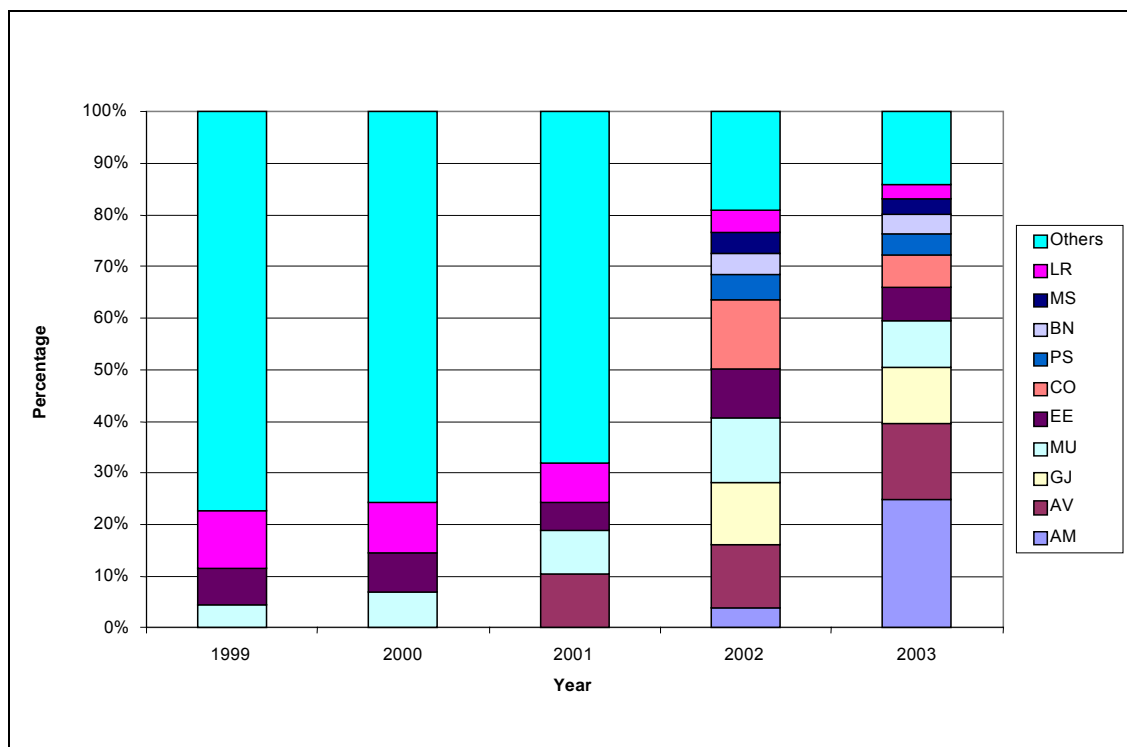

Figure 5.7 The Big Ten of GHG Emitters from Flaring

Source: own calculations

5.2 Calculation of Gas-to-Oil Ratio (GOR)

As mentioned in Chapter 3, the GOR calculation in this study will be based on the ratio of associated gas to oil production from each oil field and company. This value will determine the types of reservoir fluids, their behaviours, compositions and how this influences field development planning (see Table 3.6). However, the unknown accuracy of data on temperature and pressure when gas and oil are measured make it difficult to make a precise analysis of GOR values.

5.2.1 GOR of Oil Fields

Basically, an oil field will show a relatively constant GOR during its production years, except when it is aging. In 2003, the data necessary to calculate GOR is available for around 450 oil fields and shows values from 0 to 127,347 m³/m³. The oil fields with large GOR are presented below.

Table 5.5 Top 10 of GOR field (in m³/m³)

	1999	2000	2001	2002	2003
SN - 8	25,991	19,979	22,021	22,911	127,347
OV - 1	874	6,974	9,340	5,538	38,917
LE - 35	NA	NA	NA	6,855	13,281
SP - 37	NA	NA	NA	NA	12,488
EK - 5	6,514	7,213	9,118	11,316	12,103
UG - 7	NA	NA	NA	13,602	11,790
SP - 46	NA	NA	NA	NA	11,250
UG - 1	NA	NA	NA	0	10,525
LE - 32	NA	NA	NA	13,220	9,305
OV - 4	321	3,879	8,295	10,610	9,190

Note: NA = no available data

Source: own calculations

Each year SN – 8 field has a GOR of around 20,000 m³/m³, however it increased almost six times in 2003 because its oil and condensate production was almost zero. The second biggest GOR belongs to OV – 1 field, with the same issue as SN – 8: it shows a big difference of value in year 2003 compared to other years. It has also occurred that its oil production data has shown a number of zero.

It could be that SN – 8 and OV – 1 are old fields that produced a small amount of oil only in that year (it should be noted that this zero value needs a confirmation with the oil company) or that this high GOR was caused by the fact that both are gas fields. Table 3.6 shows that with a GOR value > 2672, this field produces wet gas. It should be noted that in 1999, according to its GOR value OV – 1 is a producer of gas condensate.

Table 5.5 shows that there are some oil fields belong to the same company, i.e. OV – 1 and OV – 4 are the property of OV, LE – 32 and LE – 35 to LE, and UG – 1 and UG – 7 to UG. Therefore it will be useful to review its GOR for the whole oil fields in a company, i. e. GOR for OV, LE, and UG in general as discussed in the next subchapter.

5.2.2 GOR of Oil Companies

Since every oil company most often has several oil fields, companies will have various numbers of GOR, one for each oil field. The companies' GOR values are estimated in this study to give a rough idea about the ratio of total amount of associated gas and oil production from each company.

Table 5.6 Top 10 of GOR companies (in m³/m³)

	1999	2000	2001	2002	2003
AT	NA	NA	NA	NA	3,416
OV	317	1,617	1,820	2,609	2,400
EK	2,071	2,248	1,815	1,978	1,939
LE	NA	NA	NA	1,687	1,630
UG	NA	NA	NA	1,837	1,101
LR	642	946	1,076	1,233	1,066
CI	518	823	619	700	973
SN	1,041	1,535	1,342	952	895
BA	818	3,012	0	3,217	846
RB	NA	NA	NA	409	560

Note: NA = no available data

Source: own calculations

Comparing Table 5.5 with Table 5.6, some companies with big field's GOR values are considered to have big GOR in general, namely SN, OV, LE, EK and UG.

In addition, a general value of GOR for Indonesia was calculated.

Table 5.7 Estimation of GOR's Indonesia

	1999	2000	2001	2002	2003
Associated gas, BSCF	396	536	538	757	548
Oil production, MSTB	600,597	593,554	527,898	490,542	460,826
GOR, scf/bbl	660	903	1,019	1,544	1,188
GOR, m ³ /m ³	117	161	181	275	199

Source: own calculations

However, it should be noted that in real life the GOR always represents a value from one oil field only. Therefore a general GOR value is not sufficient to interpret the type of fluid from each company. Instead it is recommended to make estimations from each oil field, as discussed in section 5.2.1 above.

6 Assessment of Gas Flaring Reduction as a CDM Project

This chapter discusses the technical and economic potential of GHG emission reduction projects under the CDM for flaring in Indonesia. Section 6.1 reviews the potential of flaring reduction from a technical point of view, i.e. technology of gas flaring reduction, including best practices and case studies. Section 6.2 looks at the economic potential by explaining the current and future market, price and cost, while section 6.3 discusses existing and potential projects in Indonesia.

6.1 Technical Potential

At the beginning of this section, common and basic techniques in the oil and gas industry are presented. This is followed by the types of known techniques to reduce gas flaring, including examples from some existing projects and how the technique supports local sustainable development.

6.1.1 Basic Oil and Gas Processing

Oil and gas produced from a reservoir are rarely already of export quality. Usually a well produces a mixture of oil, gas and water, as well as undesirable substances, which

have to be separated and treated for export or disposal (Jahn et al, 2001). A simple scheme of the process and steps required can be seen in Figure 6.1.

The quantity and quality of fluids produced is determined by hydrocarbon composition, reservoir character and field development scheme. The first two depend on nature while the latter is affected by technological and market constraints, e.g. customer, transport requirements, storage considerations.

Water must be separated from oil because the customer is buying oil, which should have a water content of less than 0.5%, and because water can increase cost due to a higher volume pumped, and corrosion (Jahn et al, 2001). When large quantities of water need to be separated from oil, a dehydration process is used.

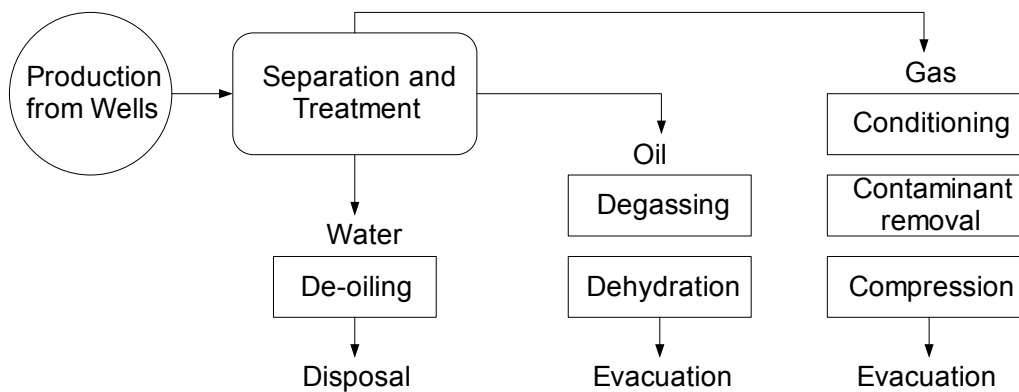

Figure 6.1 A process flow schematic

Source: redrawn from Jahn et al, 2001

After being separated from oil, water can not be disposed directly in the environment because it still contains small amounts of oil. Usually this de-oiling process is done using settling or skimming tanks.

To prepare any gas for evacuation, it is necessary to separate gas and liquid phases, as well as any unwanted component such as water vapour. In the case of associated gas, it can be sold or, when there is no gas market, its natural gas liquids can be extracted before the gas is flared or re-injected. The contaminant should be removed to avoid corrosion and toxicity, e.g. from hydrogen sulphide.

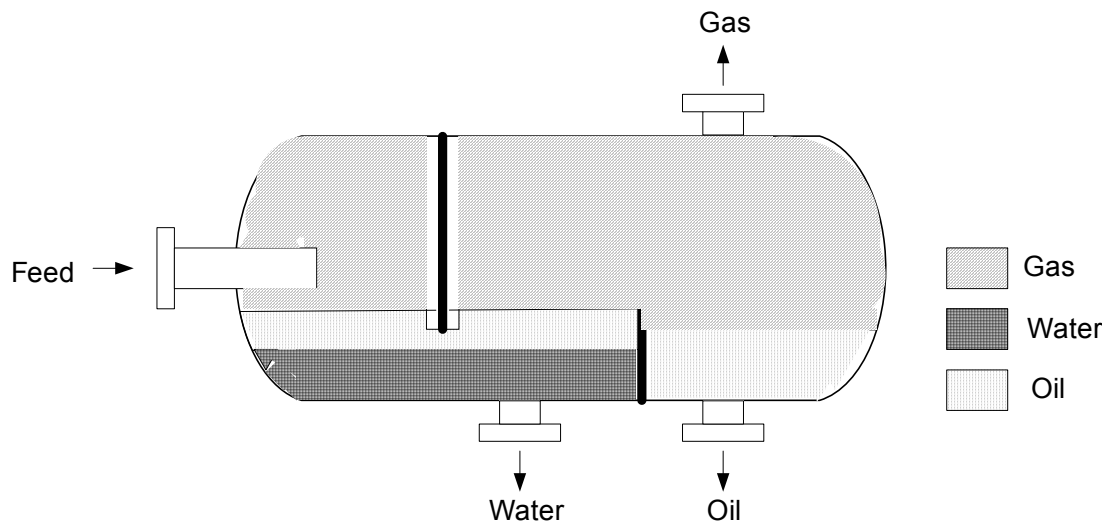

Figure 6.2 Basic Three Phase Separator

Source: redrawn from Jahn et al, 2001

6.1.2 Techniques on Gas Flaring Reduction

In dealing with associated gas, it is important to first identify all gas conservation alternatives. Some technologies correlated with CDM projects concerning associated gas and reducing gas flaring aim to use AG for local/site (re-injection), domestic (power plants, small-scale use) and international markets (Natural Gas Liquids, pipelines, Gas-to-Liquids or GTL).

All techniques mentioned below are done either in upstream, downstream or both. For downstream activities, which basically have to involve parties other than the producer (oil company), a clear structure of gas industry, regulations for tariffs and prices, technical, safety and environmental standards are needed.

In some cases, the kind of technology to be used can be matched with the natural condition of the fields' locations (GGFR, 2004c):

- for (sub)tropical regions: electrical power could be combined with LPG
- for cold regions: supply of piped gas to larger consumers

6.1.2.1 Gas Re-injection

Gas re-injection is the re-injection of natural gas into an underground reservoir, typically one already containing both natural gas and crude oil, in order to increase the pressure within the reservoir and thus induce the flow of crude oil. This process needs a pressure as high as 700 bar or 70,000 kPa (Jahn et al, 2001).

Gas re-injection is done particularly at remote fields with no market outlet for gas. Associated gas which cannot be flared can be injected into reservoirs to supplement recovery by maintaining reservoir pressure. Basic liquid separation will be performed, and the high pressure makes it important to first dehydrate the gas. It should be noted that gas pressure is much higher than gas pipeline pressure, therefore a special compressor lubricant that will not dissolve in high pressure gas is needed.

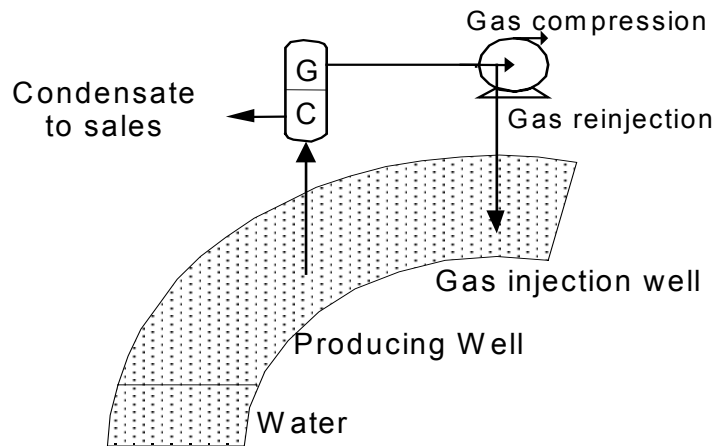

Figure 6.3 Gas re-injection process

Source: redrawn from Jahn et al, 2001

One example of the gas re-injection process is the Sanha Condensate Project in Angola (Shinn, 2004). It aims to eliminate flaring from existing platforms, as well as to increase oil production by gathering, processing and re-injecting associated gas.

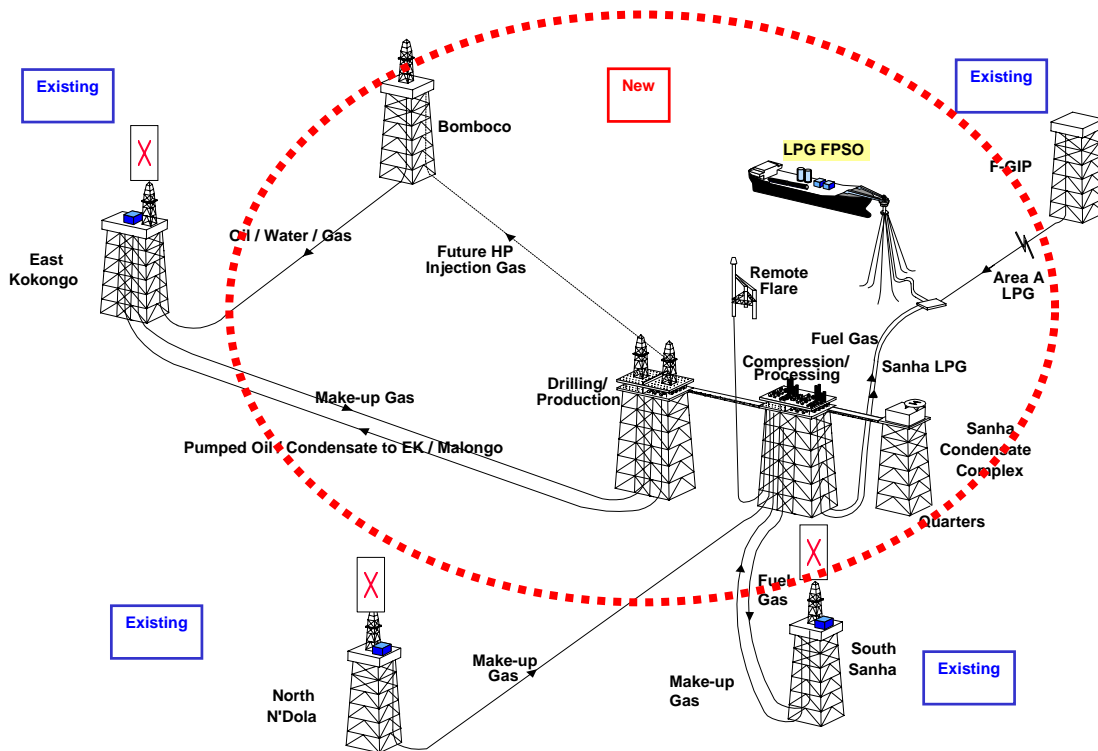

Figure 6.4 Sanha Condensate Project, Angola

Source: Shinn, 2004

When completed, the Sanha Condensate Project will produce up to 100,000 barrels per day of oil, condensate and LPG (ChevronTexaco, 2004). The condensate and the LPG will be extracted from 650 million cubic feet per day of gas. With the addition of associated gas from the surrounding platforms, the complex will separate the high-value hydrocarbon liquids from the gas. The condensate will be mixed with the oil and sent by pipeline to the Malongo terminal. The LPG will be sent by pipeline to a floating production, storage and offloading vessel (FPSO). Meanwhile, the natural gas will be re-injected back into the reservoir to maintain reservoir pressure, prevent losses and to significantly help achieve the important goal of reducing routine flaring. The project is projected to be started in 2005 with an investment of US\$ 2 billion (Shinn, 2004). From the point of view of sustainable development, the Sanha Condensate Project would support environmental sustainability by reducing three million tons of CO₂ equivalent per year.

6.1.2.2 Natural Gas Liquids Recovery

The composition of natural gas varies from non-associated gas (methane) to rich associated gas containing natural gas liquids (NGLs). NGLs are those components

remaining once methane and all non-hydrocarbon components have been removed (Jahn, et al 2001).

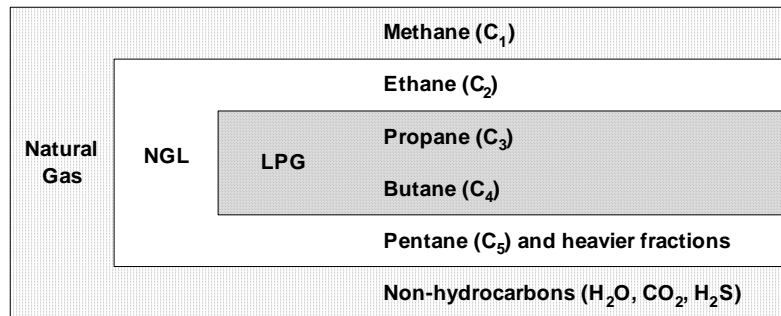

Figure 6.5 Terminology of natural gas

Source: Jahn, Cook & Graham, 2001

It may be beneficial to extract NGL before flaring or re-injection if the volume of associated gas is very big. NGL is natural gas consisting of ethane (C₂), propane (C₃), butane (C₄) and pentanes (C₅). To maximise recovery of each component, gas would have to be processed in a fractionation plant which consists of several columns. The first column removes ethane, while the heavier hydrocarbons go to the next column (de-propaniser) where propane is separated and so on. These types of plants require high investment, but less complete NGL recovery methods may be cost effective. Butane and propane can be further isolated and sold as Liquefied Petroleum Gas (LPG).

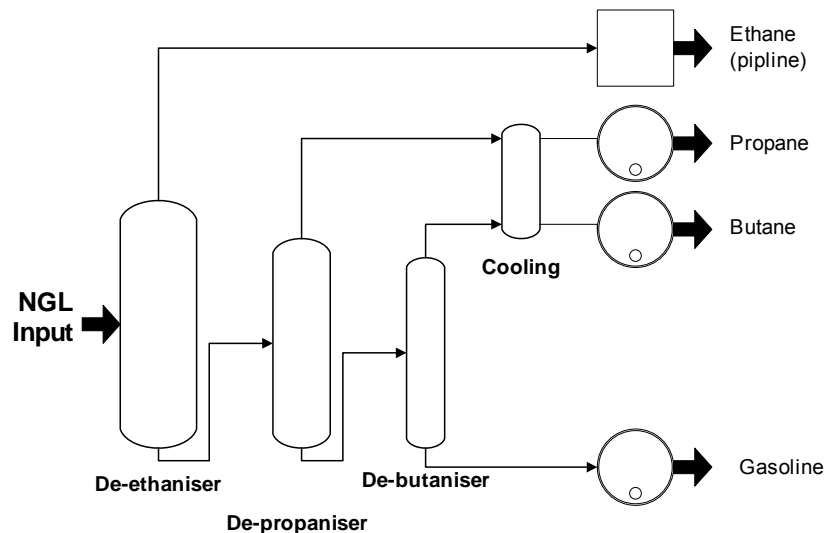

Figure 6.6 NGL Fractional Plant

Source: redrawn from Jahn, Cook & Graham, 2001

Currently the production, export and usage of NGLs has increased in many countries (Paradowski et al, 2003). Nigeria is one example of a country which uses this type of technology to increase gas usage and reduce gas flaring. Mobil is in a joint venture with Nigerian National Petroleum Corporation (NNPC) in the Oso oil field, whose NGL project is located offshore in Nigeria and reached its full capacity in 1999 with a production of 38,000 barrels of NGL's per day (Mbendi, 2000 and Lawal, 2004).

Recent news shows that NNPC expanded this joint venture by establishing an agreement with ExxonMobil to do a second NGL project in Bonny Island (Lawal, 2004). This project, known as the East Area Natural Gas Liquids (*NGL II*) project, would produce about 180 million barrels of NGL during the life of the project and is financed through foreign banks and investment outfits for an amount of \$1.275 billion.

The project involves the construction and operation of an offshore NGL extraction platform, undersea pipeline infrastructure, and onshore fractionation and storage facilities at Bonny River Terminal. Construction is expected to begin in November 2004, and would be completed in three years, in late 2007 or early 2008. The project will produce about 42,000 barrels of NGL daily, thereby doubling NGL production from the JV's operations. It will supposedly commercialise associated gas now being flared. Natural Gas Liquid will be recovered and lean gas will be re-injected for pressure maintenance/artificial lift in support of additional oil recovery, as well as contribute to the reduction of gas flaring and associated carbon dioxide emission.

This study case of NGL recovery in Nigeria shows how this technology affects its sustainable development. Besides reducing greenhouse gas emissions, it also demonstrates how technological sustainability can be achieved by developing new technology, i.e. NGL recovery process.

6.1.2.3 Gas to Pipeline

In this type of technique, gas is captured and transported by pipeline to end users. The objective is to transport (natural) gas to commercially viable markets. In its implementation, it is possible to split this project into upstream and downstream components. Upstream activities consist of associated gas transportation into pipelines, which reduces greenhouse gas emissions, while downstream activities involve a fuel switch from oil to gas, which results in lower emissions.

Gas to pipeline technology has multiple benefits, such as a reduction in flaring by using associated gas as alternative fuel, reducing air pollution and improving health. However, there are some barriers as well, including policies and regulation issues, namely government support, pricing, taxation and regulatory structure. In addition, financial problems might rise if the investment is high but profitability remains questionable. Current and future markets will influence the feasibility of the project, as well as the possibility of leakage and boundary determination.

One gas pipeline example is the West African Gas Pipeline (WAGP), which aims to supply Benin, Togo and Ghana (Shinn, 2004).

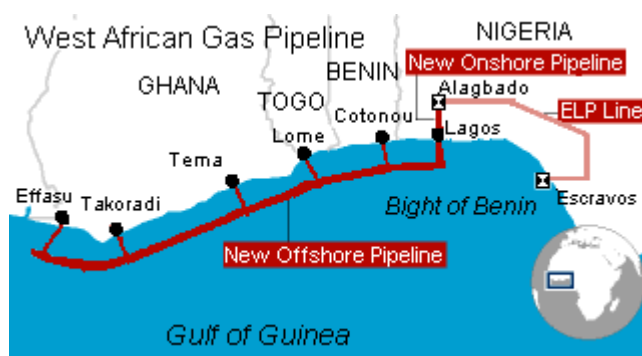

Figure 6.7 West African Gas Pipeline (WAGP) Project

Source: EIA, 2003

The WAGP will cover 1,033 kilometers from both on and offshore Nigeria's Niger Delta region to its final destination in Ghana (EIA, 2003). The first portion of the pipeline, which will deliver gas to the greater Lagos area (Alagbado), is already in existence. The Escravos-Lagos pipeline (ELP) is owned and operated by Nigerian National Petroleum Corporation. The WAGP will continue offshore, with proposed landfall spurs at Cotonou (Benin), Lome (Togo), Tema (Ghana), Takoradi (Ghana) and Effasu (Ghana). The initial capacity of the WAGP will be 200 MMSCFD; with its ultimate capacity at 400 MMSCFD (Shinn, 2004).

This project will begin to transport gas to Ghana, Benin and Togo in June 2005. A feasibility study was completed in 1999, in which the World Bank stated that the countries could save about \$500 million in primary energy costs over 20 years (Mbendi, 2000). The major positive environmental impact of the project will be the use of gas currently flared in Nigeria. In addition, cleaner-burning gas supplied by the WAGP will replace petroleum products used in the generation of electricity.

All explanations above show how this type of technology affects environmental and technological sustainability. In addition, there are also social and economic impacts. A study estimates that 10,000 to 20,000 primary sector jobs will be created in the region by WAGP (EIA, 2003). New power supplies, fueled by gas from the project, will stimulate growth of new industry. This industrial growth has a potential to spawn an additional 30,000-60,000 secondary jobs. In addition to the \$1 billion in investment (WAGP and power facilities) already projected, the study sees approximately \$800 million in new industrial investment occurring in the region.

6.1.2.4 Improving Flare Efficiency

For a flare burning a mixture of hydrocarbon fuels, the efficiency was characterized by the “carbon conversion efficiency”, which is defined as the effectiveness of the flare in converting the carbon in the fuel to carbon in CO₂ (Kostiuk et al, 2004). There is significant site-to-site variation in the flaring volumes, gas composition, and ambient conditions for solution gas flares, which means every field has different gas flare efficiency as well.

Low efficiency flares do not completely combust all of the fuel gas, and unburned hydrocarbons and carbon monoxide are emitted from the flare along with carbon dioxide. In addition, low efficiency of flaring will cause the increase of venting. This is an unwanted effect, since venting emits methane, which is 21 times more potent than carbon dioxide from flaring. Therefore the flare efficiency improvement will eliminate/reduce venting, because a larger share of AG production will be flared rather than vented.

Research activities in 1996 – 2004 by Kostiuk, et al in Alberta, Canada show that flare efficiency is influenced by fuel type, wind speed (U_{∞}), exit velocity (V_j), stack outside diameter (d_o), and the specific energy content of the fuel mixture (expressed here as the lower heating value, LHV_{mass}).

$$(1 - \eta) \cdot (LHV_{mass})^3 = A \cdot \exp\left(B \frac{U_{\infty}}{(g V_j d_o)^{1/3}}\right)$$

where $(1 - \eta)$ is inefficiency, A and B are coefficients. For natural gas based flare streams, $A = 133.3 \text{ (MJ/kg)}^3$ and $B = 0.317$ while for propane and ethane $A = 32.06 \text{ (MJ/kg)}^3$ and $B = 0.272$.

Wind had a strong impact on the combustion efficiency of these flares. At relatively low crosswinds ($U_{\infty} < 2$ m/s), the efficiencies are very high (> 99 %), but as the wind speed is increased, the efficiency falls dramatically. The observed dependency of the overall efficiency on changes in exit velocity and stack diameter was less dramatic than the dependency on wind speed. Flares with higher exit velocities and larger stack diameters were less susceptible to the effects of wind.

The effects of flare stream composition were explored by diluting the fuel (either methane in the natural gas flares or propane) in the flare stream with either carbon dioxide or nitrogen. The data shows that increasing CO₂ in the fuel had a strong, nonlinear impact on the inefficiency of the flare. Energy density is reported as both the higher heating value (HHV) and the lower heating value (LHV). As the fuel energy density is reduced, the flame becomes more susceptible to the crosswind, and the rapid rise in inefficiency begins at much lower wind speeds.

6.1.2.5 Gas-to-Liquids

Gas-to-Liquids (GTL) is production of liquid fuels from a different primary energy source, namely gas. Some study cases in Africa show that to produce 1 barrel of synfuel, it take 10,000 scf of natural gas (at 50% efficiency) (Belguedj, 2001).

There are two broad technologies for gas to liquid (GTL) to produce a synthetic petroleum product, (syncrude): a direct conversion from gas, and an indirect conversion via synthesis gas (syngas). The direct conversion of methane, (typically 85 to 90 per cent of natural gas), eliminates the cost of producing synthesis gas but involves a high activation energy and is difficult to control (Chemlink Pty Ltd, 1997).

Indirect conversion can be carried out via Fischer-Tropsch (F-T) synthesis or via methanol. The process is named after F. Fischer and H. Tropsch, the German coal researchers who discovered it in 1923.

The Fischer – Tropsch process consists of three steps (Schubert et al, 2001):

1. Synthesis gas formation: $CH_n + O_2 \xrightarrow{\text{catalyst}} \frac{1}{2}n H_2 + CO$
2. Fischer – Tropsch reaction: $2n H_2 + CO \xrightarrow{\text{catalyst}} -(CH_2)_n + H_2O$
3. Refining: $-(CH_2)_n \xrightarrow{\text{catalyst}} \text{fuel, lubricants, etc.}$

Synthesis gas, a mixture of hydrogen and carbon monoxide, is reacted in the presence of an iron or cobalt catalyst; such products as methane, synthetic gasoline and waxes, and alcohols are made.

Use of GTL for chemical and energy production is forecast to advance rapidly due to increasing pressure on the energy industry from governments, environmental organisations and the public to reduce pollution (Chemlink Pty Ltd, 1997). The opportunity to develop existing technologies shows how GTL can introduce technological sustainability. In addition, an environmentally motivated advantage of GTL technology relates to the concern in some countries about the disposition of associated gas. A GTL project can use gas that would otherwise be vented or flared as a feedstock. However, it is also clear that the commercial success of GTL technology has not yet been fully established, due to high costs and a limited number of projects. As a generalisation, GTL is not competitive up against conventional oil production unless the gas has a low opportunity value and is not readily transported.

In 1997 only three GTL facilities operated to produce synthetic petroleum liquids at more than a demonstration level: the Moss gas Plant (South Africa), with output capacity of 23 000 barrels per day, Shell Bintulu (Malaysia) at 20 000 barrels per day and the subsidised methanol to gasoline project in New Zealand. A joint project in Nigeria from Chevron and Sasol Ltd has been announced with a 30 000 barrel per day plant that would cost \$1 billion, using the Sasol Slurry Phase Distillate process (Mbendi, 2000).

In another possible use of Indonesia's gas resources, Shell is examining the possibility of building a gas-to-liquids (GTL) plant in Indonesia. The plant, if the project goes forward, would produce 70,000 bbl/d of diesel and other middle distillates using the Fischer-Tropsch GTL process (EIA, 2004b).

6.1.2.6 Fuel Switch

Power generation is one of the major potential markets for gas. Natural gas can be used either as a substitute to currently used liquid fuels, or as a means to increase installed capacity efficiency through diversification (Belguedj, 2001). The utilisation of gas as an alternative fuel in power generation facilities can lead to economic, environmental and efficiency benefits. In conventional power stations, gas can displace liquid fuels in steam turbines and reciprocating engines.

In addition, improvements in technology has made gas-based power generation facilities very efficient. The use of two types of turbines - a combustion turbine and a steam turbine - in combination, known as a "combined cycle," is one reason why gasification-based power systems can achieve unprecedented power generation efficiencies. The efficiency of combined cycle power plant is roughly 60% (Belguedj, 2001). A conventional coal-based boiler plant, by contrast, employs only a steam turbine-generator and is typically limited to 33-38% efficiencies (US DOE, 2004b).

Higher efficiency means that less fuel is used to generate the rated power, resulting in better economics (which can mean lower costs to ratepayers) and the formation of fewer greenhouse gases (a 60%-efficient gasification power plant can cut the formation of carbon dioxide by 40% compared to a typical coal combustion plant).

In some locations, this technology is very suitable due to the wide range of capacities available, its flexibility, and its short construction time. The benefits mentioned above also show how fuel switching encourages sustainable development in economic, technological and environmental aspects.

One example of the usage of this technique for reducing gas flaring is a project in Tomsk, Russia (GGFR, 2003). About 1.5 billion cubic meters of associated gas is annually flared due to lack of facilities and infrastructure. A project of expanding generation capacity is proposed, which installs a Combined Cycle Gas Turbine (CCGT) fuelled by AG. In this project, AG requires no treatment and can be fed directly into the CCGT unit. This technology has operation flexibility, short installation time, low emissions of SO_x sulfur oxides, NO_x nitrogen CO₂ and is suitable for use in cogeneration. In cogeneration, utilization may be up to 80–90 percent, while at the same time electrically generated at an efficiency rate above 40 percent. This CCGT unit is expected to achieve more than 50 percent plant operating efficiency compared to the 35–40 percent achieved by steam turbine technology.

6.1.3 Best practices: Argentinean Case

In the early 1990s, Argentina privatised its energy sector. Since 1992, the gas industry has been encouraged to develop, mainly through the use of flared gas and open or combined cycle natural gas turbine technology. In 1997, around 44% of electricity in Argentina was produced with natural gas (Bouille et al, 2000).

Due to the discovery of large gas fields, coal and oil are being replaced with gas. This has been supported by an extensive gas pipe network and a price policy in favour of gas usage in transportation, household and industrial sectors. In addition, there are large amounts of service stations selling compressed natural gas (650 stations in 100 towns and cities).

Due to an energy policy from the Argentinean energy department which foresees replacing oil and coal with hydroelectricity, nuclear energy and natural gas, the emissions of greenhouse gases from fossil fuel consumption are declining. Also for this purpose, some innovative studies and projects are underway to decrease the climate change effect. One of the GHG mitigation projects is the CO₂ re-injection project in the Puesto Hernández oil field in the Neuquén and Mendoza provinces. The Neuquen Basin is located in the central part of the country. It holds nearly 50% of the country's total remaining hydrocarbon reserves (both oil and gas). The basin has an extensive oil and gas pipeline network, with oil lines connected to export ports on the Atlantic and Pacific coasts, to local refineries and to refineries in Buenos Aires, as well as gas pipelines to the major domestic markets. Three major oil pipelines begin at Puesto Hernandez in the Neuquen basin, which accounts for over one-third of Argentina's current production (US DOE, 2004a).

In this project, CO₂ is used to decrease oil viscosity in the well and increase oil volume to extract larger amounts. This type of technology will increase oil recovery and prevent greenhouse gas emissions. It will prevent the release of 148,000 tons CO₂ eq in three years of the pilot project. Furthermore, if the final project is implemented, 5.5 million tons CO₂ eq will be saved over a 15-year period (Bouille et al, 2000).

Some personal discussions with crew involved in this project reveal that in 1992 this field flared 12% of its national gas production. Since then, the companies have made many investments in capturing and using the gas. Currently 140 - 150 MMm³ gas is produced daily. Some is re-injected or retained in plants as LPG and gasoline, while 1000 MMm³ is flared annually, i.e. about 1-1.5 % of total production.

Some advantages to this project include the elimination of flaring and the fact that useless CO₂ is not produced. Some new power plants have been installed in the oil fields as well. However, the abundance of gas reduces its price. Currently gas costs about US\$ 0.75 per MMBtu, while three years ago the price was twice as high.

Another way to reduce carbon emissions is by preventing natural gas flaring. The Argentinean government is gradually applying some regulations that abate gas flaring. According to Argentinean regulation, companies can lift process and market associated gas. They can also use it in operation or re-inject or flare it (GGFR, 2004e). However, permission is needed to flare excess gas that cannot be marketed. As of January 1, 1994, the venting of natural gas is prohibited from wells with a gas-oil ratio exceeding $100 \text{ m}^3/\text{m}^3$. This regulation was extended to wells with lower gas-oil ratios of $1 \text{ m}^3/\text{m}^3$ as of January 1, 2000. There are exemptions for some cases, such as in locations where the venting takes place in remote and low-productivity areas, or when associated gas is contaminated with hydrogen sulfide, nitrogen, carbonic acid gas, or other gases.

The law also regulates that the flare systems are to be designed and operated in accordance with the best industrial practice and engineering standards. Its criteria consist of the flare efficiency, flare performance characteristic and process leakage. National data indicates that between 1994 and 1997 gas flaring was reduced from 3.4 billion m^3 to less than 2 billion m^3 with an investment of US\$ 350 million, even though oil production volumes increased steadily over the same period (Bouille et al, 2000).

To summarise, gas flaring reduction projects in Argentina prove to be supportive to the country's development in all aspects, including socio-economic, environmental and technological growth. The introduction of certain projects has enhanced the promotion of alternative technology and production which opened a new gas market, domestically and internationally. The regulations also played a big role by lowering dependency on oil and coal as well as encouraging the usage of previously flared gas as alternative fuel, which resulted in a reduction of greenhouse gas emissions.

6.2 Economic Potential

The economic aspects of associated gas are influenced by several factors: regulations, standards on flaring reduction targets, financial incentives such as royalty and tax, and the utilisations and markets that support the commercialisation of associated gas. The sections below discuss the opportunity to reduce flaring by commercialising it.

6.2.1 Gas Markets

According to Kaldany, most current gas markets are not fully efficient due to regulations, monopolies etc (Kaldany, 2001). Therefore it is required to undergo reforms in investment, financing, energy price, regulation and governance, as well as fuel choice flexibility.

These reforms are also necessary for Indonesia: despite its large gas reserves (three times more than its oil reserves) not all potential gases are commercialised, due to the unaccommodating gas market conditions in Indonesia. In addition, the gas quality and distance from fields to markets make it more difficult to sell the gas.

Currently most of Indonesia's natural gas is marketed for export, while the rest is either used domestically or flared (around 6 percent). However, this industry is changing due to more competitive LNG markets, new pipeline exports, and increasing domestic gas demand.

6.2.1.1 Domestic Gas Market

The main domestic customers for natural gas in Indonesia are fertilizer plants and petrochemical plants (34 percent), followed by the power industry (25 percent) (US Embassy, 2004a). It is estimated that domestic natural gas demand will increase 9-11 percent per year (BPMIGAS, 2004). Roughly 55 percent of Indonesia's natural gas was marketed as LNG or liquefied petroleum gas (LPG) for export, 7.7 percent for electricity, 7.4 percent for fertilizer and 2.2 percent for city gas. Less than six percent was flared (US Embassy, 2004b).

Currently, most of the fields are situated far away from the market resulting in low consumption of gas. In addition, Indonesia has an inadequate gas transmission and distribution network, with a total pipeline length of 2,547 kilometers and a total capacity of 830 million cubic feet per day or 8.6 billion cubic meters per year. However, the government and industry are trying to develop Indonesia's domestic gas market. The Oil and Gas Law of 2001 introduced some changes to create a new domestic market: simplification of the domestic gas sales process, enabling direct negotiations between buyer and seller. In the past, production sharing contractors (PSCs) had to sell their gas to the state-owned petroleum company, Pertamina, which in turn sold the gas to the final buyer. In addition, fuel subsidy reduction is meant to encourage people to choose

gas as an alternative fuel, by making petroleum fuel more expensive. The fuel subsidy was decreased from \$7.6 billion in 2001 to \$1.6 billion in 2003, a 78 percent reduction. According to Pertamina's published fuel prices, this makes natural gas, at \$2.50-\$3.00/mmbtu, much more attractive than fuel oil (\$4.85/mmbtu) and diesel (\$5.53/mmbtu).

To solve the problem of gas distribution, the Indonesian government plans three more transmission projects to meet rising power sector demands for gas.

Table 6.1 Gas Transmission Projects

Project	Length	Capacity	Estimated Completion
a. Grissik-Jakarta	606 km	400 mmscfd	2006
b. E.Kalimantan-Java	1620 km	1500 mmscfd	2010
c. E.Java-W.Java	680 km	350 mmscfd	2010

Source: US Embassy, 2004b

The rising power demands in important islands like Java and Bali, i.e. around 8% per year, is a cause of increased domestic gas demand. The PLN's gas turbine combined cycle (GTCC) plants in Java are running on fuel oil because of declining gas supply and transmission problems in East Java. Petroleum fuels are expensive – about 6.2 cents per kilowatt hour (kWh), or 2.5 times more costly than gas. PLN spends about \$1.7 billion annually on oil-based fuels and estimates it can save up to \$1 billion per year by switching to gas. The switch, when coupled with the power utility's plans to raise electricity tariffs to 7 cents/kHz, is an important element in restoring the financial health of Indonesia's power industry (US Embassy, 2004a).

Even though the domestic gas market is promising, more effort is needed. Reform in pricing could be important for developing local demand for natural gas. Furthermore, inadequate transmission and distribution systems, financing issues, and regulatory uncertainty may block the gas development.

6.2.1.2 International Gas Market

Since local markets will be insufficient, international markets are most important for associated gas. EIA projected that consumption of natural gas worldwide will increase

2.2 percent annually from 2001 to 2025, mostly for electricity generation. Currently, Indonesia's major crude oil customers (in rank order) are Japan, South Korea, Australia, Singapore, China and the United States.

However, the existence of new competitors in the gas industry are forcing Indonesia to find new markets. One of the focuses is neighbouring countries, namely ASEAN members in South East Asia. Indonesia is part of an effort on the part of the Association of Southeast Asian Nations (ASEAN) called the Trans-ASEAN gas pipeline (TGAP) project. Indonesian energy ministers agreed in 2002 to have a regional gas transmission network in order to reduce the consumption of oil and to provide backup energy sources for ASEAN members. The developments have been done in Singapore and Malaysia, with a study to build one in Thailand. 1,000 kilometers of the grid have already been constructed, while ASEAN has identified the need for 4,500 kilometers of pipeline to complete the project. This \$7 billion project would create a natural gas supply network to improve regional power generation and economic development (US Embassy, 2004b). All of TGAP projects are expected to be completed by 2020. This means a new market and also a new opportunity for revenues from gas. The project also presents a new incentive to reduce gas flaring.

6.2.2 Carbon Prices

At present, there are not enough transactions and liquidity in the carbon market. Due to different contracts, lack of liquidity and uncertainty about developments in the future, the range of price differences is considerable. In fact, for most transactions so far, few details, if any, are made public. In particular prices or contract structures often remain confidential (Lecocq, 2004).

Some of several determinants in pricing carbons are the market segment and the structure of the transaction. For example, for non-Kyoto emission reduction, the price is lower than that of projects which aim to comply with the Protocol (see Figure 6.8). For transactions intended for Kyoto compliance, it could be the buyer or the seller who takes the registration risk.

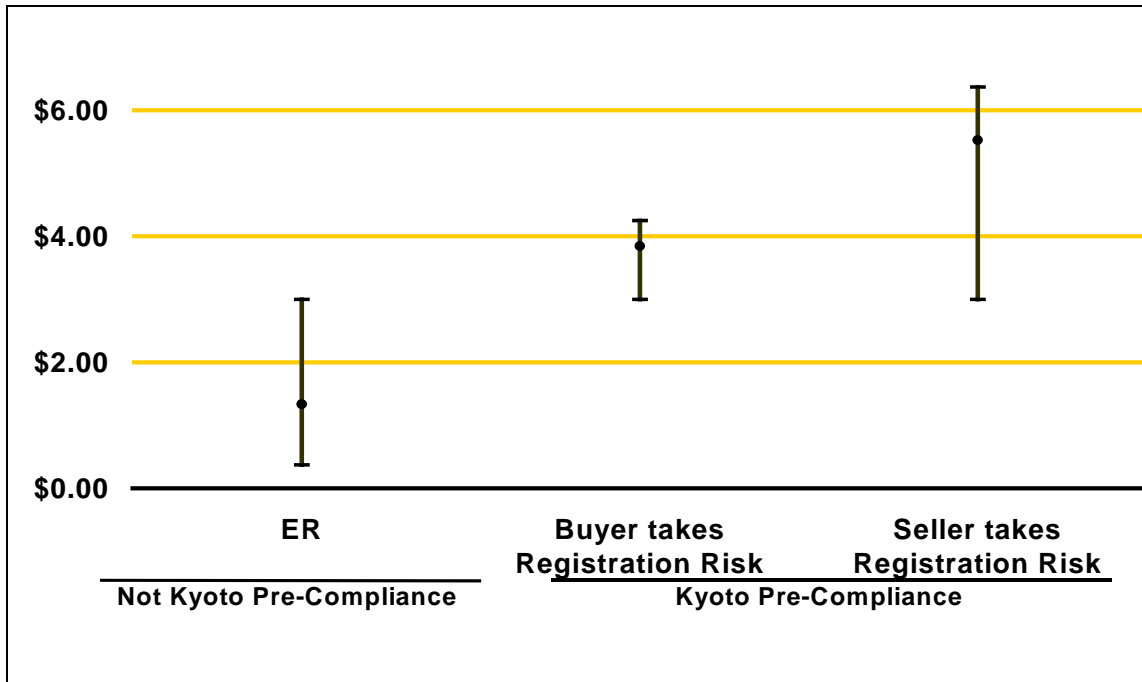

Figure 6.8 Carbon Prices (in US\$ per ton CO₂ equivalent)

Source: Carbon Finance, 2004

According to PCF, prices vary greatly depending on the nature of the commodity traded. First, ERs not aiming for Kyoto compliance command a price between \$0.37 and \$3.00/tCO₂e. Within the transactions intended for Kyoto compliance, VERs sell at \$3.00 to \$4.25 (weighted average \$3.85), while registration risk on the seller commands a higher value of \$3.00 to \$6.37 (weighted average \$5.52)(Lecocq, 2004).

Another study done by Point Carbon shows that the buyers' preferred price range is about €3 - 6.5/tCO₂e. This range might reflect the influence of existing dominant purchasers, like Dutch CERUPT as well as the World Bank Prototype Carbon Fund, which have both purchased CERs for prices within this range. However, sellers are increasingly keeping their CERs and ERUs to sell later on, thus expecting a higher price than the current one (Point Carbon, 2004)..

The other key determinants of price are the buyers' willingness to pay, experience of the project sponsor and the viability of the project. In addition, confidence in the quality and delivery of ERs over the life of the project will affect the price, as well as the existence of regulatory risk (e.g. Kyoto Protocol entry into force, eligibility of project, verification and certification). In some cases, buyers do want to pay more for projects that support additional environmental and social benefits.

A research on the preferences of Annex I countries concerning CER prices is summed up by Point Carbon in 2003 and is shown in Table 6.2.

Table 6.2 Annex I Parties' preferred CER price range and payment terms

Country	Preferred price range and payment terms
Austria	Market price. Up front payment possible.
Denmark	Price preferences not decided. Max. price for domestic reductions: 18USD. Payment on delivery. Tender information not yet made public.
Finland	About €3 (for the CDM projects in its portfolio). Up front payment possible
Germany	About €5. Payment terms currently being discussed.
Japan	None, but detailed examination of project agreements
Netherlands	6.7 USD is max. price. May pay more for renewable energy projects. Payment on CER issuance.
Sweden	5 USD. May pay more for sustainable projects. Up front payment possible.

Source: Point Carbon, 2003

According to the World Bank, there are two alternatives for market development in the future. The market could be formed into a large, single market with one price. However, the other possibility is that the market will be fragmented due to the different reduction targets from country to country. For both alternatives, the market price itself will be influenced by demand, which depends on the entry into force of the Protocol, and the supply side.

For gas flaring reduction projects, the carbon price will be influenced by the project-based credits and the expected price at the international market. The current market prices are in the range of US\$ 3 – 7 per ton CO₂ (PCF, 2004). However, the market is still not very developed. For calculation, GGFR recommends a price of US\$ 7 – 20 per ton of CO₂ to be used (GGFR, 2004c). For example, in 2003 Indonesia produced 10 million tons CO₂ eq from gas flaring (it is not impossible that the real number is bigger than reported). If only 10% is eligible for CDM projects, the value might be US\$ 3 – 7 million (with current carbon price) or € 2.3 – 5.5 million (US\$1 = € 0.786 according to Yahoo's currency converter in October 2004).

6.2.3 Transaction Costs

Transaction costs arise from the transfer of any property right. This will affect the cost for participants and could lower the trading volume, and even discourage some transactions from occurring (Michaelowa & Stronzik, 2002). In the Kyoto Mechanisms,

transaction costs accrue at different stages in the process of a transaction or project cycle.

Table 6.3 Definition of transaction cost components of JI and CDM projects

Transaction cost components	Description
Pre-implementation	
Search cost	Costs incurred by investors and hosts as they seek out partners for mutually advantageous projects
Negotiation costs	Includes those costs incurred in the preparation of the project design document that also documents assignment and scheduling of benefits over the project time period. It also includes public consultation with key stakeholders
Baseline determination costs	Development of a baseline (consulting)
Approval costs	Costs of authorisation from host country
Validation costs	Review and revision of project design document by operational entity
Review costs	Costs of reviewing a validation document
Registration costs	Registration by UNFCCC Executive Board / JI Supervisory Committee
Implementation	
Monitoring costs	Costs to collect data
Verification costs	Cost to hire an operational entity and to report to the UNFCCC Executive Board /Supervisory Committee
Review costs	Costs of reviewing a verification
Certification costs	Issuance of Certified Emission Reductions (CERs for CDM) and Emission Reduction Units (ERUs for JI) by UNFCCC Executive Board /Supervisory Committee
Enforcement costs	Includes costs of administrative and legal measures incurred in the event of departure from the agreed transaction
Trading	
Transfer costs	Brokerage costs
Registration costs	Costs to hold an account in national registry

Source: Michaelowa & Stronzik, 2002; Dudek & Wiener, 1996; PriceWaterhouseCoopers (2000)

This refers to administration process in a project cycle such as consulting costs for determining baseline, validation by DOE, registration by UNFCCC EB and issuance of CER for CDM projects. The costs could accrue to the governments/international institutions and private funding. For CDM projects, generally transaction costs have to be paid privately. These costs could be reduced when the participants are more experienced with this mechanism. The costs are predicted to decline as the market develops: lower costs are the sign of adoption of standardised baselines and other procedures. In addition, countries with inefficient regulations will need higher transaction costs which may lower their competitiveness against other countries.

Some researches show that costs rise with the number of OE involved and that costs per ton CO₂ reduction are negligible for larger, but significant for smaller projects (Michaelowa and Stronzik, 2002). For example, a project with a reduction of more than 200,000 t CO₂ per year would incur a transaction cost of 0.1 EUR per ton, while a reduction of less than 200 tons per year would incur a cost of 1,000 EUR per ton. For this reason, very simple modalities and procedures should be applied for small scale projects.

Table 6.4 Project size, type and total transaction costs

Size	Type	Reduction (tCO ₂ /a)	Transaction cost (€ t CO ₂)
Very large	Large hydro, gas power plants, large CHP, geothermal, landfill/pipeline methane capture, cement plant efficiency, large-scale afforestation	> 200,000	0.1
Large	Wind power, solar thermal, energy efficiency in large industry	20,000 – 200,000	1
Small	Boiler conversion, DSM, small hydro	2000 – 20,000	10
Mini	Energy efficiency in housing and SME, mini hydro	200 – 2000	100
Micro	PV	< 200	1000

Source: Michaelowa and Stronzik, 2002

There is no specific reference/study case on transactional costs of gas flaring reduction projects at this point. However, the above discussion could be applied as well. The technology needed to reduce gas flaring is expensive, therefore it must be considered for larger projects. With 400 MMSCFD gas flared (5% of total gas production) in 2003, which emitted 10 million tons CO₂ equivalent, Indonesia might consider using the gas for projects under CDM. Problems will supposedly appear due to geographical and distribution issues, because this potential from gas flaring is distributed over various oil fields.

Due to the above mentioned reasons, the projects in this analysis will be considered for large scale purposes only, i.e. projects with a reduction of more than 20,000 tons of CO₂ equivalent per year.

Based on observation of big emitters of GHG in Indonesia (see Table 5.4), in general, all big emitters have an opportunity to reduce more than 20,000 tons of CO₂ equivalent (assuming that 10% of their total emissions are eligible for CDM projects). This means that the gross values are around €45,000 – 110,000 while the transaction cost is about €20,000. In 2003 AM emitted 2.5 million tons of CO₂ equivalent. If only 10% is eligible

as CDM projects, the total carbon project has an amount of 250,000 tons of CO₂ equivalent of reduction. Even for AM which has the opportunity to undertake a project with more than 200,000 tons of CO₂ equivalent, the transaction cost is smaller: for a cost of € 0.1/tCO₂e, the total transaction cost will be 25,000 while the gross values are more than €580,000. However, this is an estimation based on total GHG emission per company. The potential of realising this will depend closely on the GHG amount emitted by oil field(s) and their locations. In the case of remote areas and large distances between oil fields, the transaction cost will depend on how the oil companies manage to bundle projects from different oil fields.

For example, CO is accounted for at least 36 oil fields (due to lack of data, their exact locations are unknown). Despite higher emission amounts, LR supposedly has a bigger chance of having a gas flaring reduction project under CDM because LR has a major oil field (LR – 1), which dominates almost 100% of the company's production and gas flaring. Even for big emitters, for example AM (number one in gas flaring and greenhouse gas emissions in 2003), it will be a challenge to minimise transaction costs for a relatively large scale project.

6.2.4 Financial Viability

A 'classic' determination of economic and financial feasibility is based on the net present value (NPV) of the cash flow for the specific period. In addition, it is expected that the projects have a low Internal Rate of Return (IRR), while the ones with higher IRR are considered to be weaker. It is generally more difficult for a high IRR to pass the test but high IRRs should not be ruled out. These two criteria are not explicit eligibility criteria.

Based on methodology AM0009 (Rang Dong oil field), The IRR should be determined using several parameters, including overall projected gas production, the projected quantity of gas recovered, the agreed price for the delivery of recovered gas, the net calorific value of the gas, capital expenditure for gas recovery facilities, pipelines, etc. (CAPEX), operational costs (OPEX), and any cost recovery or profit sharing agreements (UNFCCC, 2004a).

The project activity can be considered additional if the IRR of the project activity is lower than the hurdle rate of the project participants (typically about 10%). Financially

viable projects may be eligible if barriers can be documented, and the combination of CDM as an institution, the project design and credits overcome these barriers. Basically, some cases show that subsidies for gas flaring reduction are not needed, except when the markets are far from production, the gas deposits are small, or when fuel subsidies exist (which is the case in Indonesia).

One example of this issue is shown in gas flaring reduction projects in the Sedigi field, Chad (GGFR, 2004c). The Sedigi oil project is currently developed and most of its associated gas is planned to be flared. Some alternative scenarios to use associated gas are evaluated:

- Scenario 0: all associated gas is flared
- Scenario 1: switch power plant's fuel from oil to gas
- Scenario 2: scenario 1 + transfer associated gas to a brick factory
- Scenario 3: scenario 2 + LPG at refinery Farcha

Depending on the possibilities for gas use, the percentages of associated gas which can be used will vary. For each scenario, there are two production cases: In the first case (Case 1) no gas is flared and the oil production is reduced to the level required to achieve this goal of no flaring. In the second case (Case 2) the refinery is assumed to have a throughput reflecting the demand for petroleum products in Chad even though this entails some flaring.

A financial analysis is carried out based on assessment of benefits and costs of the three projects. The financial investment costs are estimated as below:

Table 6.5 Financial Investment Costs per Case and Scenario, million US\$

Investment Cost	Case 1 Minimized flaring	Case 2 Reflecting demand
Scenario 0	78.1	98.0
Scenario 1	114.1	134.0
Scenario 2	114.1	134.0
Scenario 3	114.1	134.0

Source: GGFR, 2004c

The operation and management costs have been estimated at 5 % of the investment costs. The financial feasibility is based on the NPV for 15 years with a discount rate of 15% per year.

Table 6.6 Financial Analysis Case 1—Minimization of Flaring

CASE 1	Income	Costs	Net Income	Marginal income, reduced flaring	Obtained CO₂ reduction million ton (as NPV)	Needed support US\$/ton of CO₂
Scenario 0	175.7	76.4	99.3	-	-	-
Scenario 1	206.0	111.5	94.4	-4.9	0.5	9.6
Scenario 2	208.5	111.5	96.9	-2.4	0.5	4.3
Scenario 3	221.4	111.5	109.9	10.6	1.1	-9.5

Source: GGFR, 2004c

Table 6.7 Case 2—Production Reflecting Demand for Refined Products

CASE 2	Income	Costs	Net Income	Marginal income, reduced flaring	Obtained CO₂ reduction million ton (as NPV)	Needed support US\$/ton of CO₂
Scenario 0	191.2	95.8	95.5	-	-	-
Scenario 1	219.3	130.9	88.4	-7.1	0.5	13.9
Scenario 2	221.9	130.9	90.9	-4.6	0.5	8.3
Scenario 3	235.7	130.9	104.8	9.3	1.2	-8.1

Source: GGFR, 2004c

The results show that financially, flared gas use from the Sedigi oil field is viable in the case of LPG production (scenario 3). When interpreting the above results it should be noted that it is realistic to achieve a financial CO₂ credit of US\$3–5 per ton CO₂ reduced. However, flared gas use will not be financially viable in the other scenarios since it is presently unrealistic to achieve carbon credits of US\$10–14 per ton CO₂ reduced.

6.3 CDM Projects in Gas Flaring Reduction in Indonesia

6.3.1 Existing Project

In general, the current CDM activities are being undertaken by large companies. This means less risk in project financing, large scale projects and less risk in CER deliverables. In addition, some local companies have started to prepare PDDs.

6.3.1.1 The Yakin Flare / Vent Reduction Project by Unocal

The discussion in this section is based on an Unocal representative's presentation at Global Gas Flaring Reduction's Regulatory Capacity Building Workshop in Bandung, Indonesia, March 15 – 16, 2004.

Yakin is an offshore oil field near Kalimantan, Indonesia. Operation started in 1975, and in 1998 flare reduction efforts began as market access increased to a refinery in Balikpapan, a city near this oil field. The project consists of installation of compressors, retrofit of pumped lift (ESP or Electric Submersible Pump) to replace gas lift and replacement of diesel power with gas turbine-generators. ESP completions are an alternative means of obtaining artificial lift in wells that have low bottom hole pressures. ESP completions are the most efficient choice for high volume capable wells. Production rates up to 90,000 barrels of fluid per day (around 14,000 m³ per day) have been obtained using large ESP's (Baker Hughes, 2004).

After three years of operation, gas flaring has been reduced: in 1998 there was about 41 MMSCFD (= 424 MMm³) of gas flaring, while in 2001 the amount was reduced to 11 MMSCFD (= 114 MMm³). By estimating the greenhouse gas emissions using the CAPP guide, there was a reduction of around 260,000 tons of CO₂ per annum.

Currently new investment is necessary for further reduction. It is foreseen that in eight years, the carbon reduced should be 2.5 million tons CO₂ equivalent, roughly around 300,000 tons of CO₂ per year. Compared to calculation above, this means that the project must prevent gas flaring evenmore. As the company has a preliminary commitment for ~50% of GHG emission reductions, it is not unrealistic to achieve this goal. Current project performance shows that even though flaring has fluctuated, on average it has been reduced since 2001. On the other hand, this project needs a capital of US \$13 MM, and according to this company, carbon credits can make it economically viable.

This Yakin project is the first oil and gas candidate project in Indonesia. Currently the project is operating and reducing greenhouse gas already, however it still faces some constraints regarding the "ownership" of the credits, treatment of CDM value and credit marketing.

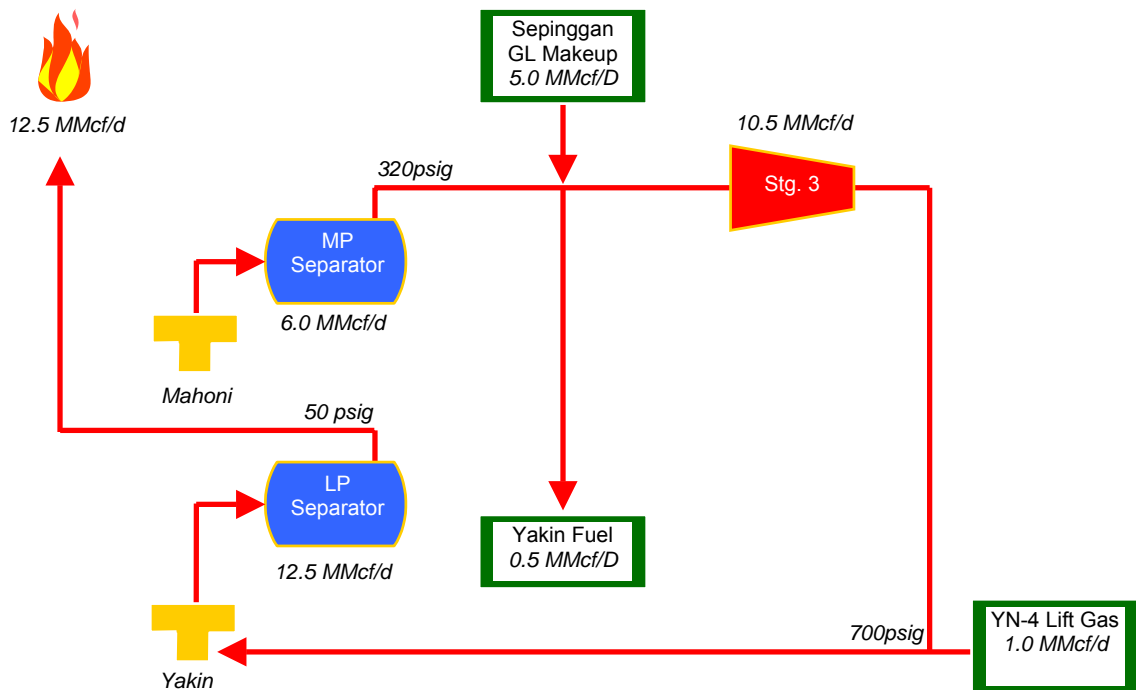

Figure 6.8 Flow Schematic without ESP

Source: Newell, 2004

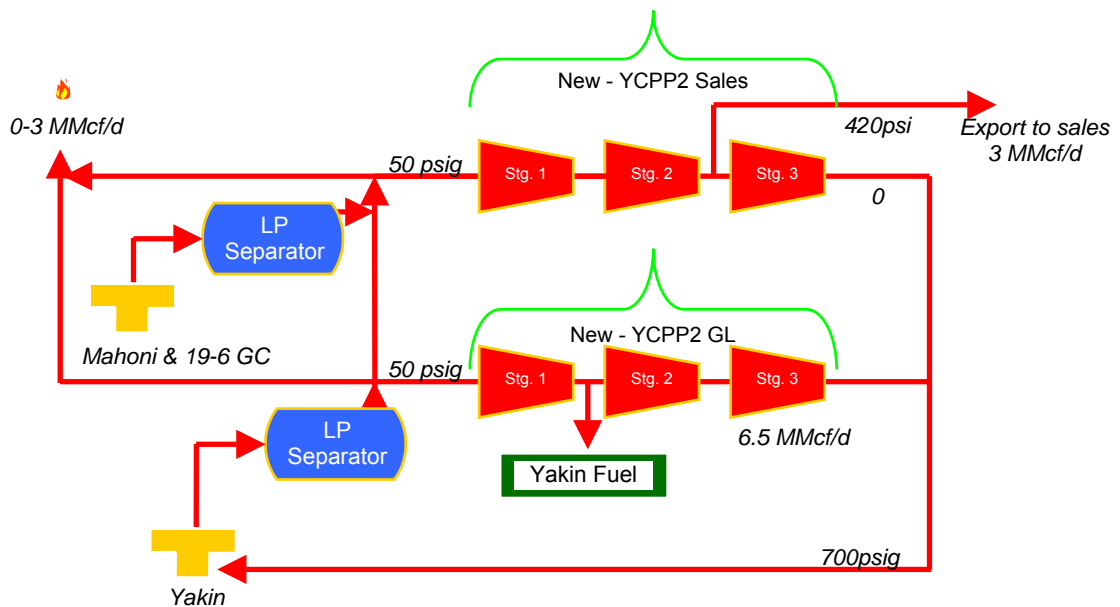

Figure 6.9 Current Flow Schematic (with ESPs, no lift gas)

Source: Newell, 2004

6.3.1.2 Flare Gas and Hydrogen Recovery Project by NEDO

This section describes a project by NEDO, based on presentations at Global Gas Flaring Reduction's Regulatory Capacity Building Workshop in Bandung, Indonesia, March 15 – 16, 2004 and at Carbon Expo in Cologne, June 2004.

NEDO's working group on gas flaring proposes to recover flare gas and hydrogen in a refinery, which processes 260,000 barrel of crude oil/day. Emissions come from refinery fuel burning, which consists of an off-gas of more than 6 kg/cm² released from the refinery and returned as fuel. The excess gas will be used as fuel gas or returned to the refinery as LPG feed, while the excess hydrogen will be utilized in Hydrocracking Unit. In addition, emissions occur due to flare gas venting, fuel burning to generate electricity. In HCU, emissions are produced because of CO₂ forming during Hydro cracking process and fuel burning for hydrogen generation.

Some scenarios established:

- Scenario 1: No FRS-HRS, unchanged capacity
- Scenario 2: No FRS-HRS, increased capacity
- Scenario 3: FRS-HRS by Project Sponsor
- Scenario 4: FRS by Project Sponsor
- Scenario 5: FRS-HRS plus increased capacity by Project Sponsor

The available comparison exists between Scenario 1 and 4 only.

Table 6. 8 Comparison between Scenarios 1 and 4

	Scenario 1	Scenario 4
Fuel Cost Reduced	\$19,386,167/year	\$4,630,167/year
Energy Use Added	-\$1,386,083/year	-\$1,169,917/year
Maintenance Added	-\$618,273/year	-\$439,516/year
Total Cost Reduced	\$17,381,811/year	\$3,020,734/year
Investment (\$)	-\$20,609,083	-\$14,650,533
IRR excluding CERs	55%	11%
Cash In from CERs	\$1,493,735/year	\$365,860/year
IRR including CERs	60%	15%

Source: Sari, 2004

This project will reduce 268,800 t CO₂e/year in Flare Recovery System and 84,200 t CO₂e/year for Hydrogen Recovery System (Priambodo, 2004).

As the refinery is located onshore, it will have some advantages due to its relatively easy access to local market. Even though this project is not a typical gas flaring project, the carbon reduction can still be traded. The project sponsor itself can and will invest on FRS, therefore there are no barriers to financing/investments.

The emission reduction will occur as shown in the following figures.

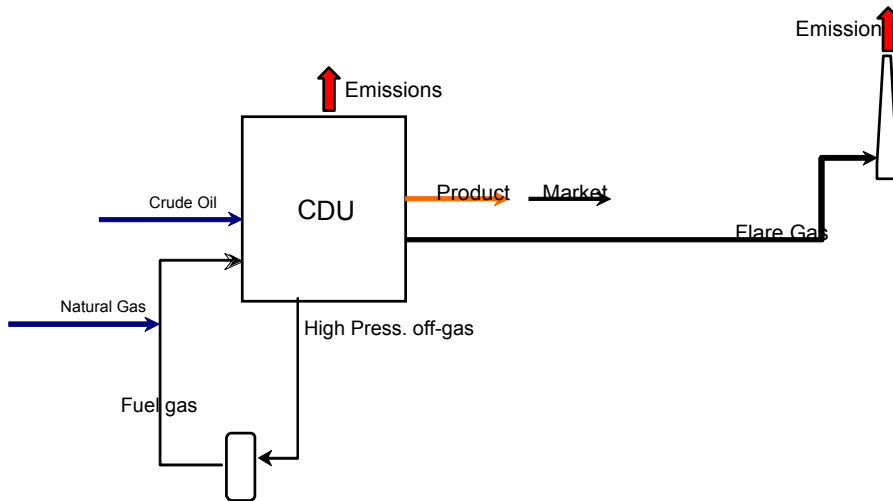

Figure 6.10 CDU System without FRS

CDU = catalytic dewaxing unit, the first distillation step in a refinery separating the crude oil into naphtha, kerosene, gas oil and long residue; FRS = flare recovery system; HCU = hydro cracking unit; HRS = hydrogen recovery system; ER = emission reduction

Source: Sari, 2004

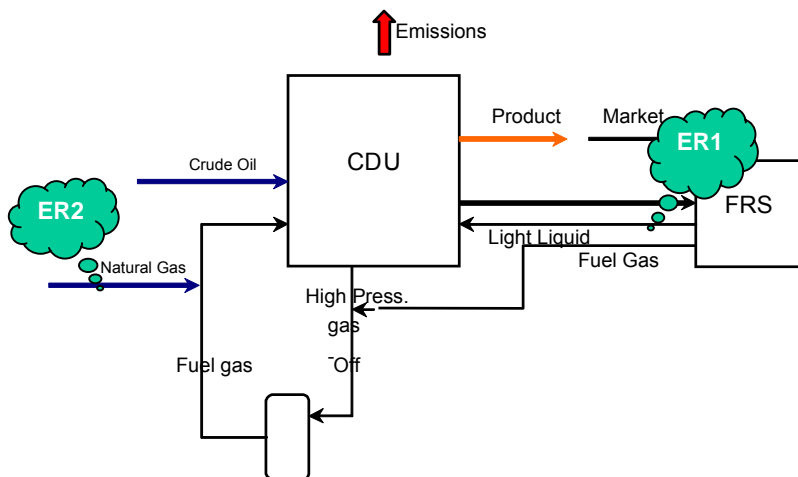

Figure 6.11 CDU System with FRS

Source: Sari, 2004

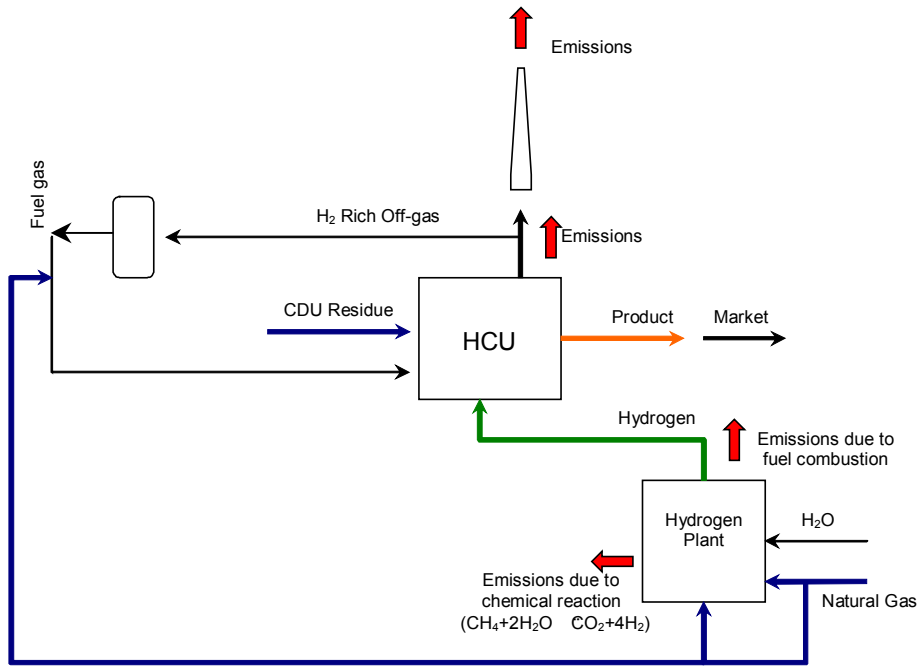

Figure 6.12 CDU System without HRS

Source: Sari, 2004

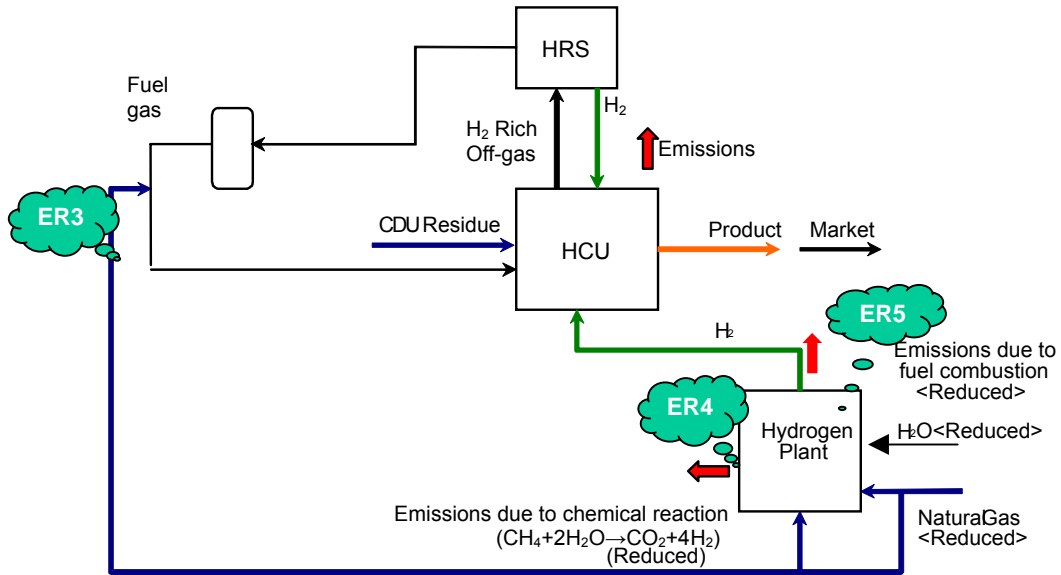

Figure 6.13 CDU System with HRS

Source: Sari, 2004

6.3.2 Future Development of CDM in Gas Flaring Reduction in Indonesia

Chapters 4 and 5 portray Indonesia's potential for gas flaring reduction projects under CDM. Large amounts of flaring, presumably due to the opening of new wells and fields, open an opportunity to hold large CDM gas flaring reduction projects.

Even though it is projected that this seventeenth oil producer in the world will produce less crude oil in the future, its gas production will develop due to the high demand and market growth, not only domestically but also globally.

As of yet there is no big market for associated gas, but this is expected to grow as exports develop. The key is the distance between markets and the field. The pipelines' cost may hinder the development of a market. Most fields in Indonesia are in remote areas, mainly onshore. However, some cities with high energy demand are located around the fields, particularly the cities outside Java such as Balikpapan, Duri, and even Jakarta, the capital. The current development of gas pipelines to Singapore and Malaysia may even add the cities around the pipe distribution to the market.

However, the recovery of associated gas requires investment. It also requires a gas gathering system to collect raw gas and transport it to a treatment unit where LPG is removed. Furthermore, a compressor is needed to re-inject the gas to a reservoir or distribute it via pipeline.

Another issue with establishing a gas market is the fuel subsidy. The price of fuel oil is subsidised, giving it a low price and making it difficult for gas to compete with it. If the fuel subsidy is eliminated, the price of oil will increase and gas can become an alternative fuel.

To establish a gas market, the institutions must show support by confirming regulations and the rules of the game: who owns the gas and what the contractual parties' responsibilities are. The government may establish regulations to encourage associated gas usage, as well as incentives to decrease flaring of natural gas.

Efforts must be made to make the net revenues from marketing gas more attractive than the financial benefits of flaring.

As discussed in the section on economic potential, it is more feasible to have gas flaring reduction projects on a large scale, especially for Indonesia which has many remote area

oil fields. In some cases however, it is feasible to start small scale projects in small fields with local market access.

Regarding the costs, there is no exact figure on how much the mitigation cost for gas flaring reduction in Indonesia is; however, some modeling done in the past, e.g. MARKAL (in NSS, 2001), shows costs of 1.1 – 1.9 US\$/ton CO₂. It should be noted that these figures are not a formal estimation. In general, transaction costs are difficult to estimate. These depend on the domestic institutional setup as well as CDM's rules. Through minimum transaction costs, the opportunity to have CDM projects in Indonesia will increase. But the real potential and project cost will depend on the type of baseline used. Therefore the baseline is a crucial step in designing CDM projects.

According to BPMIGAS, some efforts are currently being made to reduce gas flaring, such as the building of several utilization facilities for electric and steam generators, the building and re-running of LPG plants, re-injection to reservoirs, and export to Singapore and Malaysia. In addition, the usage of associated gas and reduction of gas flaring is promoted by expanding and establishing electric power generators and pipeline distribution, as well as by establishing good coordination between gas producers and consumers.

Further studies regarding these efforts are recommended, including detailed data and location regarding the projects. In addition, the assessment of conditions before and after these efforts will show which technology is more efficient, useful and feasible for certain locations and at the same time show how carbon reduction is affected.

7 Facilitation of Gas Flaring Reduction Projects in Indonesia

In Indonesia, oil companies may lift, process and market associated gas jointly with BPMIGAS. In addition, they can use associated gas in operations or re-inject or flare gas that cannot be marketed. However, associated gas is still considered as a by-product of oil which can disturb the oil flow. Due to a lack of markets, institutions and regulations, the associated gas is simply flared instead of being used. The flaring of natural gas is a consequence of a cost minimisation strategy, as well as a lack of regulations.

To reduce/eliminate flaring, suitable conditions are needed, including supportive institutions. In addition, close cooperation with stakeholders, including government and investors, is a pre-requisite to implementing the policies and projects. The government must implement legislation and policies that will attract new private direct investment and rationalize use of Indonesia's energy resources. Energy policy reform is necessary in order to enhance the efficient use of energy resources.

Current conditions show that there are large emission sources in Indonesia, and CDM projects in gas flaring reduction offer high real and long term emission reductions. Among buyers there is interest in pursuing a gas flaring reduction project. However, the barriers are quite high: people prefer to use oil as their main fuel, because it is cheaply available in large amounts.

In using CDM projects for gas flare reduction, 'learning by doing' is vital due to the lack of knowledge and experience on how to design such projects.

Suggestion for the stakeholders:

- sound monitoring, measurement and calculation of gas flaring
- enhance the transparency of information on the gas volumes flared through public reporting
- capacity building on gas use possibilities should be introduced
- further research on how gas flaring reduction projects could be structured, technically and commercially, to ensure implementation
- a study on gas use strategy
- confirm and recheck the data with oil companies

- to promote CDM activities in gas flaring reduction, it is necessary to provide clear and detailed information about its benefits, especially because it involves a lot of investments. In addition, CDM's complicated procedures may hinder the stakeholders' willingness to participate. Through awareness of its profits, this constraint could be cleared up
- analyse the current petroleum fiscal legislation to review the profitability of gas field development
- conduct pilot projects to reduce gas flaring in fields with adequate gas quantities
- further research is recommended on competition conditions, i.e. potential from other oil producers. For example, why does China (the first largest oil producer in Asia) have less GHG emissions than Indonesia (the second largest producer).
- historical data of GHG emission in Indonesia starts in 1995 (in NSS: historical for 1990 – 1994, projection for the years after 1994)
- need for informed discussion on its contribution to sustainable development

In the end, it is hoped that the participants of CDM can receive some benefits:

- Technology transfer to host nation
- Transfer of skills and knowledge
- Renewable or sustainable energy
- Environmental improvements
- Reduction of GHG emissions
- Lower compliance costs in Annex B

8 Summary

Climate change is a problem that affects all regions in the world, therefore all developed and developing countries must make efforts to reduce it. Clean Development Mechanism (CDM), as one of flexible mechanisms of the Kyoto Protocol, is an opportunity for developed countries to reduce carbon emissions by investing in projects in developing countries. On the other hand, projects under CDM will support developing countries to achieve sustainable development.

CDM projects could be applied to various sectors, including energy from oil and gas, particularly from gas flaring reduction. As a big player in the oil (number 17) and gas (number 6) industry, Indonesia has the opportunity to take part in CDM on gas flaring reduction. Through a CDM project in gas flaring reduction, the economic use of gas will be maximized.

There is not yet a regulation/policy for how this type of CDM project in gas flaring reduction should be done. But there are some standards that any project should fulfil in order to be listed as a CDM project, i.e. eligibility and additionality criteria. From the sustainability point of view, a GFR project will support sustainable development in economic, environmental, social and technological ways.

Concerning Indonesia's potential to hold CDM projects on gas flaring reduction, data from oil and gas activities show that Indonesia's oil production has slowly decreased each year until 2003. From 1990 to 2025, Indonesian production is projected to show a tendency of decline because the new fields' projects need several years to begin their production, while most existing oil fields in Indonesia are aging.

Since 1996, the oil production has decreased but amounts of flaring have increased. In 1990, 457 MMSCFD gas was flared, while in 2003 the amount decreased slightly to 399 MMSCFD. Presumably the new wells, even though they are small in numbers, do a lot of flaring.

In the beginning of the 80s, flaring contributed to almost 20% of gas production, while recent years show that its percentage has decreased to less than 5% despite an increase in total gas production. From this number, 85% is born by ten companies.

Almost 12 million tons of CO₂ equivalent was emitted in 1990 and reached its peak in 1992 with more than 15 million tons CO₂ equivalent, while after that year a decline is

observed. Indonesia accounts for an average of 6% of the total world GHG, while Asia in general contributes more than 8% of it. However, Indonesia contributes more than 70% of Asian greenhouse gas emissions from flaring while India contributes 12%, Vietnam 6%, Philippines 5%, and Burma 2%.

Comparing greenhouse gas emissions from flaring with total Indonesian GHG emissions, shows that flaring contributes around 2 – 4% of total emissions. In 2003, 80% of total GHG emissions in Indonesia were borne by ten companies.

In the year 2003, the GOR from 450 oil fields shows a range from 00 to 127,347 m³/m³, while for companies, the highest value is 3,416 m³/m³. Indonesia's GOR in general is estimated to be around 1,200 scf/bbl, equals to 200 m³/m³.

Despite large gas reserves, three times more than its oil reserves, not all potential gas in Indonesia is commercialised, due to the unaccommodating gas market condition in Indonesia. In addition, the gas quality and distance from fields to markets make it harder to sell the gas. However, the government and industry are trying to develop Indonesia's domestic gas market. The Oil and Gas Law of 2001 simplified the process of domestic gas sales, enabling direct negotiations between buyer and seller. In addition, fuel subsidy reduction make it more attractive for people to choose gas as an alternative fuel, as petroleum fuels become more expensive.

Another important market for associated gas is international markets. Currently, Indonesia's major crude oil customers are Japan, South Korea, Australia, Singapore, China and the United States. Opportunities are to be seen in new markets in neighbouring countries, namely Singapore, Malaysia and Thailand.

The global carbon market in general is expected to grow because the total volume of emission reductions up to 2012 will be no higher than 10% of the anticipated demand for emission reductions from countries in Annex B of the Kyoto Protocol. In addition, the thought that participation in the carbon market is 'risky' due to uncertainty regarding the timing of Kyoto Protocol most likely will be solved in the near future, as Russia is going to ratify the Protocol in October 2004.

At present, the carbon price differs from around US\$ 3 – 7 per ton CO₂ eq. For gas flaring reduction projects, the carbon price will be influenced by the project-based credits and the expected price on the international market.

Regarding the mitigation costs of gas flaring reduction projects, data from NSS show the cost of 1.1 – 1.9 US\$/ton CO₂. It is difficult to estimate transaction costs because it depends on the domestic institutional setup as well as CDM's rules, but having minimum transaction costs will increase the opportunity of starting CDM projects in Indonesia.

Some technology correlated with associated gas and gas flaring reductions are, for example, gas re-injection, gas to pipeline, improved flare efficiency, Natural Gas Liquids recovery, GTL and fuel switch. It should be noted that large scale projects in gas flaring reduction are more feasible, especially for Indonesia which has many oil fields in remote areas. But some cases show that small scale projects in small fields with local market access are feasible as well.

One key point in gas flaring reduction under CDM projects is government support. The government may establish regulations to encourage associated gas usage, as well as incentives to decrease flaring of natural gas. Efforts must be made to make the net revenues from marketing gas more attractive than the financial benefits of flaring. Reform in pricing could be important in developing the local demands for natural gas.

Appendix

	Page
Appendix A	Kyoto Protocol Article 12 – The Clean Development Mechanism .. 106
Appendix B	Annex I Countries of the Climate Convention and Annex B Countries of the Kyoto Protocol 108
Appendix C	The Indonesian Sustainable Development Criteria and Indicators ... 109
Appendix D	Oil Production in Indonesia (million cubic meters) 111
Appendix E	Gas Production in Indonesia (million cubic meters) 114
Appendix F	Gas Flaring in Indonesia (million cubic meters) 116
Appendix G	Calculations of Greenhouse Gas Emission from Gas Flaring 118
	G1. GHG Emission (tonnes CO ₂ equivalent) based on API Compendium, according to oil production 118
	G2. GHG Emission (tonnes CO ₂ equivalent) based on API Compendium, according to gas flaring 122
	G3. GHG Emission (tonnes CO ₂ equivalent) based on CAPP Guide, according to gas flaring 124
Appendix H	Gas-to-Oil Ratio 126

Appendix A

Kyoto Protocol Article 12 – The Clean Development Mechanism

KYOTO PROTOCOL TO THE UNITED NATIONS FRAMEWORK CONVENTION ON CLIMATE CHANGE

Article 12

1. A clean development mechanism is hereby defined.
2. The purpose of the clean development mechanism shall be to assist Parties not included in Annex I in achieving sustainable development and in contributing to the ultimate objective of the Convention, and to assist Parties included in Annex I in achieving compliance with their quantified emission limitation and reduction commitments under Article 3.
3. Under the clean development mechanism:
 - (a) Parties not included in Annex I will benefit from project activities resulting in certified emission reductions; and
 - (b) Parties included in Annex I may use the certified emission reductions accruing from such project activities to contribute to compliance with part of their quantified emission limitation and reduction commitments under Article 3, as determined by the Conference of the Parties serving as the meeting of the Parties to this Protocol.
4. The clean development mechanism shall be subject to the authority and guidance of the Conference of the Parties serving as the meeting of the Parties to this Protocol and be supervised by an executive board of the clean development mechanism.
5. Emission reductions resulting from each project activity shall be certified by operational entities to be designated by the Conference of the Parties serving as the meeting of the Parties to this Protocol, on the basis of:
 - (a) Voluntary participation approved by each Party involved;
 - (b) Real, measurable, and long-term benefits related to the mitigation of climate change; and
 - (c) Reductions in emissions that are additional to any that would occur in the absence of the certified project activity.
6. The clean development mechanism shall assist in arranging funding of certified project activities as necessary.
7. The Conference of the Parties serving as the meeting of the Parties to this Protocol shall, at its first session, elaborate modalities and procedures with the

objective of ensuring transparency, efficiency and accountability through independent auditing and verification of project activities.

8. The Conference of the Parties serving as the meeting of the Parties to this Protocol shall ensure that a share of the proceeds from certified project activities is used to cover administrative expenses as well as to assist developing country Parties that are particularly vulnerable to the adverse effects of climate change to meet the costs of adaptation.
9. Participation under the clean development mechanism, including in activities mentioned in paragraph 3(a) above and in the acquisition of certified emission reductions, may involve private and/or public entities, and is to be subject to whatever guidance may be provided by the executive board of the clean development mechanism.
10. Certified emission reductions obtained during the period from the year 2000 up to the beginning of the first commitment period can be used to assist in achieving compliance in the first commitment period.

(Source: <http://unfccc.int/resource/docs/convkp/kpeng.pdf>, viewed on July 8, 2004)

Appendix B

Annex I Countries of the Climate Convention and Annex B Countries of the Kyoto Protocol

No	Annex I of the Climate Convention ^a	Annex B of the Kyoto Protocol: emission limitation (% of base year) ^b
1.	Australia	108
2.	Austria	92
3.	Belarus ^c	
4.	Belgium	92
5.	Bulgaria ^d	92
6.	Canada	94
7.	Croatia ^d	95
8.	Czech Republic ^d	92
9.	Denmark	92
10.	Estonia ^d	92
11.	European Economic Community	92
12.	Finland	92
13.	France	92
14.	Germany	92
15.	Greece	92
16.	Hungary ^d	94
17.	Iceland	110
18.	Ireland	92
19.	Italy	92
20.	Japan	94
21.	Latvia ^d	92
22.	Liechtenstein	92
23.	Lithuania ^d	92
24.	Luxembourg	92
25.	Monaco	92
26.	Netherlands	92
27.	New Zealand	100
28.	Norway	101
29.	Poland ^d	94
30.	Portugal	92
31.	Romania ^d	92
32.	Russian Federation ^d	100
33.	Slovakia ^d	92
34.	Slovenia ^d	92
35.	Spain	92
36.	Sweden	92
37.	Switzerland	92
38.	Turkey ^c	
39.	Ukraine ^d	100
40.	United Kingdom of Great Britain and Northern Ireland	92
41.	United States of America ^e	93

Notes:

^a Source:

http://unfccc.int/parties_and_observers/parties/annex_i/items/2774.php, viewed on October 29, 2004

^b Source:

<http://unfccc.int/resource/docs/convkp/kpeng.pdf>, viewed on July 8, 2004

^c Although they are listed in the Convention's Annex I, Belarus and Turkey are not included in the Protocol's Annex B as they were not Parties to the Convention when the Protocol was adopted

^d Countries that are undergoing the process of transition to a market economy

^e The US has indicated its intention not to ratify the Kyoto Protocol.

Appendix C

The Indonesian Sustainable Development Criteria and Indicators

There are four groups of criteria: economy (EC), environment (EN), social (S), technology (T). All are assessed in the form of checklist (no scoring, no weighting).

- **Economic sustainability**

Scope of evaluation: the area within the project's ecological border affected directly by the project activities

Criteria: Local community welfare

Indicators:

- Not lowering local community's income
- There are adequate measures to overcome the possible impact of lowered income of community members
- Not lowering local public services
- An agreement among conflicting parties is reached, conforming to existing regulation, dealing with any lay-off problems

- **Environmental sustainability**

Scope of evaluation: the area within the project's ecological border affected directly by the project activities

Criteria:

1. Environmental sustainability by practicing natural resource conservation and diversification

Indicators:

- Maintain sustainability of local ecological functions
- Not exceeding the threshold of existing national, as well as local, environmental standards (not causing air, water and/or soil pollution)
- Maintaining genetic, species, and ecosystem biodiversity and not permitting any genetic pollution
- Complying with existing land use planning

2. Local community health and safety

Indicators:

- Not imposing any health risk
- Complying with occupational health and safety regulation
- There is a documented procedure of adequate actions to be taken in order to prevent and manage possible accidents

• **Social sustainability**

Scope of evaluation: within the district (city)'s administrative border. If the project's impacts are cross-district (city), the scope extends to cover all affected districts (cities).

Criteria:

1. Local community participation in the project

Indicators:

- Local community has been consulted
- Comments and complaints from local communities are taken into consideration and responded to

2. Local community social integrity

Indicators: not triggering any conflicts among local community

• **Technology sustainability**

Scope of evaluation: within national border.

Criteria: Technology transfer

Indicators:

- Not causing dependencies on foreign parties in knowledge and appliance operation (transfer of know-how)
- Not using experimental or obsolete technologies
- Enhancing the capacity and utilisation of local technology

Appendix D: Oil Production in Indonesia (million cubic meters)

	1990	1991	1992
Indonesia	88.846	90.716	86.040

Source: recalculated from BPMIGAS

Company	1993	1994	1995	1996	1997	1998	1999	2000	2001	2002	2003
IC + TD	39.261	39.115	41.718	43.709	44.128	44.391	44.079	43.286	41.002	37.421	32.155
CO	0.000	0.000	0.000	0.000	0.000	0.000	0.000	0.000	0.000	0.000	6.673
UA	0.000	0.000	0.000	0.087	0.097	0.315	1.076	2.837	3.196	4.030	4.187
SP	0.595	4.528	7.277	7.166	5.668	5.987	4.895	3.735	2.781	2.808	3.741
EE	4.135	3.973	4.178	3.779	3.760	4.166	4.660	4.669	5.025	4.169	3.626
IR	7.014	6.547	5.611	5.144	4.676	4.208	3.741	3.741	3.356	2.762	3.278
CI	4.501	4.301	5.633	5.493	5.086	5.246	4.122	3.530	3.216	3.208	3.016
AM	4.676	2.806	2.338	2.806	2.338	2.338	2.565	2.687	2.530	2.321	2.519
AN	0.000	0.000	0.000	0.000	0.000	0.000	0.000	0.000	0.000	0.000	2.436
PP	0.000	0.000	0.000	0.000	0.000	0.000	0.000	0.000	0.000	0.000	2.209
OV	1.547	2.339	2.371	2.369	2.493	2.350	2.785	2.433	2.115	1.286	1.766
RB	0.000	0.000	0.000	0.000	0.000	0.000	0.000	0.000	0.000	0.786	0.814
LE	0.000	0.000	0.000	0.000	0.000	0.000	0.000	0.000	0.000	0.840	0.665
RU	0.000	0.000	1.533	1.311	1.162	1.040	1.040	0.976	0.866	0.800	0.644
YR	0.105	0.096	0.070	0.060	0.050	0.051	0.040	0.025	0.044	0.048	0.447
JA	0.000	0.000	0.136	0.147	0.112	0.184	0.461	0.490	0.435	0.400	0.409
NN	0.000	0.000	0.000	0.000	0.000	0.000	0.000	0.000	0.000	0.000	0.401
KN	0.000	0.000	0.299	0.490	0.673	0.886	1.012	0.757	0.514	0.484	0.381
CN	0.302	0.314	0.300	0.315	0.342	0.332	0.332	0.314	0.311	0.350	0.361
OI	0.000	0.000	0.000	0.000	0.000	0.000	0.000	0.154	0.154	0.308	0.335
GE	0.000	0.000	0.000	0.000	0.000	0.000	0.034	0.079	0.201	0.346	0.324
YE	0.000	0.000	0.000	0.000	0.000	0.383	0.355	0.369	0.341	0.348	0.323
RO	0.083	0.144	0.171	1.613	0.293	0.301	0.296	0.325	0.346	0.298	0.257
NT	0.000	0.000	0.000	0.000	0.000	0.000	0.000	0.000	0.000	0.239	0.220
LR	0.000	0.000	0.000	0.441	0.553	0.466	0.296	0.362	0.220	0.263	0.219
SN	0.000	0.000	0.000	0.388	0.306	0.259	0.224	0.131	0.149	0.198	0.214
UG	0.000	0.000	0.000	0.000	0.000	0.000	0.000	0.000	0.000	0.219	0.192
GT	0.000	0.000	0.000	0.000	0.000	0.000	0.000	0.000	0.000	0.171	0.165
IN	0.000	0.000	0.158	0.207	0.232	0.265	0.232	0.240	0.574	0.196	0.146
MI	0.000	0.000	0.000	0.000	0.000	0.000	0.000	0.000	0.000	0.150	0.145
SC	0.000	0.000	0.000	0.253	0.267	0.253	0.207	0.056	0.174	0.155	0.143
TA	0.000	0.000	0.000	0.000	0.000	0.000	0.000	0.091	0.116	0.164	0.131
NR	0.000	0.000	0.000	0.000	0.000	0.000	0.000	0.016	0.000	0.026	0.110
PA	0.000	0.000	0.000	0.000	0.033	0.000	0.000	0.053	0.064	0.082	0.109
RT	0.161	0.131	0.438	0.119	0.097	0.085	0.086	0.024	0.092	0.092	0.108
DA	0.000	0.090	0.032	0.103	0.105	0.105	0.098	0.098	0.106	0.081	0.082
NI	0.000	0.000	0.000	0.000	0.000	0.000	0.000	0.000	0.000	0.060	0.069
RA	0.000	0.000	0.000	0.000	0.000	0.001	0.010	0.018	0.081	0.072	0.063
SK	0.027	0.021	0.013	0.008	0.006	0.015	0.000	0.030	0.055	0.062	0.052
SO	0.000	0.000	0.000	0.000	0.000	0.000	0.000	0.038	0.035	0.031	0.030
KB	0.000	0.000	0.000	0.000	0.000	0.030	0.000	0.024	0.026	0.025	0.024
EK	0.010	0.021	0.100	0.070	0.048	0.051	0.039	0.031	0.033	0.026	0.022
AT	0.000	0.000	0.000	0.000	0.000	0.000	0.000	0.000	0.000	0.000	0.017
PO	0.000	0.000	0.000	0.000	0.000	0.000	0.000	0.000	0.008	0.024	0.014
EL	0.000	0.000	0.000	0.000	0.000	0.000	0.000	0.014	0.012	0.024	0.011
EI	0.000	0.000	0.000	0.000	0.000	0.000	0.000	0.001	1.422	0.000	0.006
BA	0.000	0.000	0.017	0.013	0.015	0.008	0.004	0.001	0.003	0.002	0.003
AC	0.000	0.000	0.000	0.000	0.000	0.000	0.000	0.002	0.000	0.000	0.002

Company	1993	1994	1995	1996	1997	1998	1999	2000	2001	2002	2003
TW	0.000	0.000	0.000	0.000	0.000	0.016	0.006	0.004	0.003	0.001	0.001
ET	0.000	0.000	0.000	0.000	0.000	0.000	0.000	0.000	0.000	0.370	0.000
SL	0.000	0.000	0.000	0.000	0.000	0.000	0.000	0.000	7.369	7.295	0.000
GU	0.000	0.000	0.000	0.000	0.000	0.000	0.000	0.000	0.887	1.296	0.000
YG	0.000	0.000	0.000	0.000	0.000	0.000	0.000	0.000	0.427	0.898	0.000
AB	0.000	0.000	0.000	0.000	0.000	0.708	0.723	0.704	0.785	0.779	0.000
NA	0.000	0.000	0.000	0.000	0.000	0.000	0.000	0.000	0.590	0.673	0.000
PK	0.000	0.000	0.000	0.000	0.000	1.628	1.171	1.146	0.799	0.622	0.000
KI	0.000	0.000	0.000	0.000	0.000	0.399	0.414	0.434	0.388	0.343	0.000
IT	0.000	0.000	0.000	0.000	0.000	0.000	0.000	0.000	0.311	0.291	0.000
SN	0.016	0.161	0.162	0.147	0.101	0.083	0.040	0.039	0.035	0.020	0.000
XI	0.000	0.000	0.000	0.000	0.000	0.000	0.000	0.000	0.000	0.016	0.000
SS	0.000	0.000	0.000	0.000	0.000	0.018	0.016	0.012	0.010	0.005	0.000
SR	0.000	0.000	0.000	0.000	0.000	0.000	0.000	0.000	0.000	0.002	0.000
HI	0.000	0.000	0.000	0.000	0.000	0.000	0.000	0.000	1.104	0.000	0.000
LP	0.000	0.000	0.000	0.000	0.000	0.000	0.000	0.000	0.697	0.000	0.000
UT	0.000	0.000	0.000	0.000	0.000	0.000	0.000	0.000	0.319	0.000	0.000
AS	0.000	0.000	0.000	0.000	0.000	0.000	0.000	0.000	0.239	0.000	0.000
IB	0.000	0.000	0.000	0.000	0.000	0.000	0.000	0.000	0.145	0.000	0.000
UP	0.000	0.000	0.000	0.000	0.000	0.000	0.000	0.000	0.135	0.000	0.000
GO	0.000	0.000	0.000	0.000	0.000	0.000	0.000	0.000	0.065	0.000	0.000
HE	0.000	0.000	0.000	0.000	0.000	0.027	0.024	0.021	0.015	0.000	0.000
II	7.378	7.156	6.557	5.769	5.131	4.619	4.085	3.837	0.000	0.000	0.000
DN	0.588	0.616	0.627	0.000	0.000	0.000	0.000	0.000	0.000	0.000	0.000
DT	0.058	0.062	0.057	0.040	0.036	0.000	0.000	0.000	0.000	0.000	0.000
DL	0.358	0.288	0.302	0.308	0.338	0.000	0.000	0.000	0.000	0.000	0.000
CA	0.970	0.918	0.860	0.846	0.791	0.000	0.000	0.000	0.000	0.000	0.000
OR	0.000	0.000	0.000	0.000	0.000	0.000	0.000	0.000	0.000	0.000	0.000
HU	0.000	0.000	0.000	0.000	0.000	0.000	0.000	0.000	0.000	0.000	0.000
GN	0.068	0.000	0.000	0.000	0.000	0.000	0.000	0.000	0.000	0.000	0.000
KO	0.040	0.277	0.000	0.000	0.000	0.000	0.000	0.000	0.000	0.000	0.000
JN	0.120	0.091	0.000	0.000	0.000	0.000	0.000	0.000	0.000	0.000	0.000
OD	0.000	0.098	0.635	0.092	0.076	0.035	0.038	0.000	0.000	0.000	0.000
ED	0.000	0.000	0.000	1.719	2.301	0.000	0.000	0.000	0.000	0.000	0.000
TM	0.000	0.055	0.037	0.026	0.000	0.000	0.000	0.000	0.000	0.000	0.000
GK	0.000	0.000	0.000	0.000	0.000	0.000	0.000	0.000	0.000	0.000	0.000
LI	0.446	0.000	0.000	0.000	0.000	0.000	0.000	0.000	0.000	0.000	0.000
UE	0.177	0.133	0.139	0.158	0.158	0.154	0.142	0.143	0.000	0.000	0.000
IM	0.262	0.247	0.244	0.234	0.166	0.148	0.145	0.165	0.000	0.000	0.000
LM	0.343	0.303	0.498	0.485	0.546	0.594	0.637	0.627	0.000	0.000	0.000
HL	0.444	0.177	0.891	0.739	0.928	0.958	0.698	0.991	0.000	0.000	0.000
UN	0.484	0.428	0.359	0.334	0.250	0.262	0.251	0.215	0.000	0.000	0.000
AG	0.360	0.169	0.256	0.219	0.343	0.295	0.328	0.266	0.000	0.000	0.000
GR	0.143	0.133	0.076	0.067	0.066	0.067	0.072	0.078	0.000	0.000	0.000
LA	0.000	0.000	0.000	0.000	0.000	0.000	0.000	0.000	0.000	0.000	0.000
ON	0.000	0.163	0.013	0.172	0.250	0.228	0.185	0.000	0.000	0.000	0.000
SE	0.000	0.222	0.034	0.113	0.189	0.107	0.091	0.091	0.000	0.000	0.000
SU	0.000	0.000	0.000	0.000	0.000	0.000	0.000	0.000	0.000	0.000	0.000
LO	0.233	0.307	0.359	0.348	0.381	0.000	0.000	0.000	0.000	0.000	0.000
MA	0.000	0.000	0.000	0.000	0.000	0.000	0.000	0.000	0.000	0.000	0.000
SA	0.000	0.000	0.000	0.000	0.000	0.000	0.000	0.000	0.000	0.000	0.000
OM	2.153	1.760	0.000	0.000	0.000	0.000	0.000	0.000	0.000	0.000	0.000
IO	1.204	0.941	0.714	0.000	0.000	0.000	0.000	0.000	0.000	0.000	0.000
SX	9.756	8.570	8.590	7.961	8.036	8.150	8.599	8.146	0.000	0.000	0.000
SM	0.000	0.000	0.000	0.000	0.000	0.000	0.000	0.000	0.000	0.000	0.000
BL	6.556	6.172	5.330	5.119	4.642	3.386	2.782	3.386	0.000	0.000	0.000

AI	0.000	0.000	0.000	0.000	0.000	0.000	0.000	0.000	0.000	0.000	0.000
SC	0.000	0.000	0.000	0.000	0.000	0.000	0.000	0.000	0.000	0.000	0.000
Company	1993	1994	1995	1996	1997	1998	1999	2000	2001	2002	2003
KL	0.000	0.000	0.000	0.000	0.000	0.000	0.000	0.000	0.000	0.000	0.000
TN	0.000	0.000	0.000	0.000	0.000	0.000	0.000	0.000	0.000	0.000	0.000
UK	0.000	0.000	0.022	0.026	0.033	0.000	0.000	0.000	0.000	0.000	0.000
IW	0.000	0.000	0.030	0.035	0.013	0.000	0.000	0.000	0.000	0.000	0.000
PD	1.048	1.452	0.000	0.000	0.000	0.000	0.000	0.000	0.000	0.000	0.000
GI	0.000	0.000	0.000	0.000	0.000	0.000	0.000	0.000	0.000	0.000	0.000
IS	1.307	1.085	0.842	0.000	0.000	0.000	0.000	0.000	0.000	0.000	0.000
UM	0.205	0.159	0.115	0.000	0.000	0.000	0.000	0.000	0.000	0.000	0.000
IA	0.055	0.083	0.486	0.445	0.400	0.336	0.349	0.308	0.000	0.000	0.000
LD	0.000	0.000	0.000	0.000	0.000	0.000	0.000	0.000	0.000	0.000	0.000
GY	0.908	0.843	0.699	0.696	0.641	0.793	0.544	0.466	0.000	0.000	0.000
GB	0.000	0.000	0.000	0.000	0.000	0.113	0.562	0.655	0.000	0.000	0.000
NB	0.000	0.000	0.000	0.000	0.000	0.000	0.838	0.999	0.000	0.000	0.000
RE	0.063	0.059	0.062	0.052	0.000	0.043	0.042	0.000	0.000	0.000	0.000
TE	0.000	0.000	0.000	0.000	0.000	0.000	0.000	0.000	0.000	0.000	0.000
DI	0.000	0.090	0.078	0.000	0.000	0.000	0.000	0.000	0.000	0.000	0.000
EN	0.000	0.000	0.000	0.000	0.000	0.018	0.016	0.000	0.000	0.000	0.000
Indonesia	98.159	97.642	101.468	102.241	98.357	96.902	95.487	94.368	83.929	77.990	73.266

Source: recalculated from BPMIGAS

Appendix E: Gas Production in Indonesia (million cubic meters)

	1990	1991	1992	1993	1994	1995
Indonesia	89,451	69,711	73,132	75,376	84,618	85,858

Source: recalculated from MIGAS in US Embassy report

Company	1996	1997	1998	1999	2000	2001	2002	2003
EE	11,566	14,077	17,118	19,385	23,879	25,001	23,728	24,849
LB	0	0	0	0	12,729	7,592	15,797	17,037
OV	16,524	14,593	12,940	13,518	12,806	13,147	12,427	11,118
AM	0	0	0	0	0	0	1,159	7,356
AV	0	0	0	0	0	5,151	5,497	5,524
MS	0	0	0	0	0	0	3,805	4,157
CI	3,159	3,413	4,071	4,689	4,776	4,511	4,231	4,018
BN	0	0	0	0	0	0	2,064	3,325
GJ	0	0	0	0	0	0	1,353	1,958
LR	518	720	454	466	361	828	1,172	1,452
NE	0	0	0	0	0	3,202	2,359	1,422
IC + TD	1,303	1,308	1,612	1,933	1,646	1,419	1,289	1,151
PS	0	0	0	0	0	0	828	956
MU	720	717	704	616	627	760	846	918
CO	0	0	0	0	0	0	775	610
SA	0	0	0	40	77	116	218	498
LK	66	189	310	335	285	382	337	401
GK	89	57	102	113	176	202	231	233
NM	155	211	214	170	138	142	215	228
OE	309	265	170	116	217	58	166	214
AD	0	0	0	0	0	0	182	182
NU	0	0	0	0	0	0	57	88
OW	0	0	0	0	0	0	0	84
AA	0	0	0	0	0	76	50	72
RU	63	58	62	60	57	53	68	66
GH	0	0	0	0	0	0	69	61
EK	3	48	81	70	60	52	43	56
AT	0	0	0	0	0	0	95	51
GA	0	0	0	0	0	0	28	25
DS	0	0	0	0	0	0	0	3
DE	0	0	0	0	0	0	0	3
BA	8	4	5	1	2	3	3	0
KI	0	680	652	3,395	3,503	3,347	0	0
OC	565	570	385	246	492	1,184	0	0
GU	0	0	0	0	0	970	0	0
SX	581	691	744	692	707	782	0	0
PK	0	951	676	713	625	707	0	0
AB	0	604	621	623	546	562	0	0
YG	0	0	0	0	0	197	0	0
SN	201	208	204	191	179	144	0	0
IT	0	0	0	0	0	69	0	0
NA	0	0	0	0	0	41	0	0
SS	0	87	81	65	51	39	0	0
HE	0	7	6	6	5	0	0	0

Company	1996	1997	1998	1999	2000	2001	2002	2003
II	5,899	5,859	4,699	4,912	0	0	0	0
IN	3,144	3,380	3,376	3,520	3,236	0	0	0
DT	7	0	0	0	0	0	0	0
SV	697	0	0	0	0	0	0	0
DL	642	0	0	0	0	0	0	0
JW	0	0	0	0	4,975	0	0	0
OK	0	0	0	0	0	0	0	0
ED	1,003	0	0	0	0	0	0	0
SE	86	67	86	22	0	0	0	0
SO	0	0	0	0	0	0	0	0
BL	33,086	32,066	26,104	22,492	0	0	0	0
GY	354	310	258	209	207	0	0	0
GB	0	23	137	253	584	0	0	0
IA	109	79	76	65	65	0	0	0
NB	0	0	29	42	32	0	0	0
RE	0	0	0	0	0	0	0	0
Indonesia	80,858	81,242	75,978	78,953	73,044	70,738	79,091	88,115

Source: recalculated from BPMIGAS

Appendix F: Gas Flaring in Indonesia (million cubic meters)

	1990	1991	1992	1993
Indonesia	4,721	5,747	6,155	5,972

Source: recalculated from MIGAS in US Embassy report

Company	1996	1997	1998	1999	2000	2001	2002	2003
AM	0	0	0	0	0	0	127	1,025
AV	0	0	0	0	0	368	405	610
GJ	0	0	0	0	0	0	391	449
MU	103	128	134	155	193	297	411	370
EE	135	176	154	249	215	196	314	264
CO	0	0	0	0	0	0	447	264
PS	0	0	0	0	0	0	149	169
BN	0	0	0	0	0	0	137	153
MS	0	0	0	0	0	0	142	123
LR	332	562	318	381	276	273	140	115
NU	0	0	0	0	0	0	57	88
CI	49	210	464	386	206	215	160	86
IC + TD	298	343	284	293	169	151	88	83
AA	0	0	0	0	0	75	50	72
OE	11	34	12	11	25	10	54	72
GH	0	0	0	0	0	0	69	61
NM	841	206	208	162	129	133	63	26
RU	26	21	24	24	21	20	18	24
LK	43	44	27	18	12	9	10	17
OW	0	0	0	0	0	0	0	16
EK	0	2	1	1	1	1	1	8
OV	53	74	102	81	45	22	14	7
NE	0	0	0	0	0	9	14	7
AD	0	0	0	0	0	0	20	3
DS	0	0	0	0	0	0	0	3
DE	0	0	0	0	0	0	0	3
AT	0	0	0	0	0	0	2	2
GA	0	0	0	0	0	0	1	1
GK	9	1	1	0	0	0	1	1
SA	0	0	0	0	0	0	0	0
BA	8	4	5	1	2	3	3	0
GU	0	0	0	0	0	460	0	0
SX	436	544	531	389	387	451	0	0
PK	0	706	447	399	340	283	0	0
OC	264	230	205	171	199	136	0	0
LB	0	0	0	0	0	131	0	0
AB	0	107	126	101	86	109	0	0
IT	0	0	0	0	0	69	0	0
KI	0	101	55	109	48	46	0	0
NA	0	0	0	0	0	41	0	0
YG	0	0	0	0	0	19	0	0
SN	0	11	12	11	11	8	0	0
SS	0	2	0	3	0	1	0	0
HE	0	5	5	5	5	0	0	0

Company	1996	1997	1998	1999	2000	2001	2002	2003
II	377	369	312	218	0	0	0	0
IN	51	33	14	17	10	0	0	0
DT	5	0	0	0	0	0	0	0
SV	85	0	0	0	0	0	0	0
DL	136	0	0	0	0	0	0	0
JW	0	0	0	0	187	0	0	0
OK	0	0	0	0	0	0	0	0
ED	783	0	0	0	0	0	0	0
SE	86	66	85	22	0	0	0	0
SO	0	0	0	0	0	0	0	0
BL	711	10	0	0	0	0	0	0
GY	21	11	18	31	21	0	0	0
GB	0	23	137	128	128	0	0	0
IA	0	79	76	65	65	0	0	0
NB	0	0	29	42	32	0	0	0
RE	0	0	0	0	0	0	0	0
Indonesia	4,861	4,103	3,785	3,473	2,813	3,538	3,287	4,123

Source: recalculated from BPMIGAS

Appendix G: Calculations of Greenhouse Gas Emission from Gas Flaring

G1. GHG Emission (tons CO₂ equivalent) based on API Compendium, according to oil production

Formula and example are discussed in Chapter 3.

	1990	1991	1992	1993	1994	1995	1996	1997	1998	1999	2000	2001	2002	2003
Indonesia	6,006,006	6,132,448	5,816,343	6,635,574	6,600,609	6,859,249	6,911,549	6,648,947	6,550,593	6,454,967	6,379,273	5,673,627	5,272,139	4,952,772

Source: own calculation

Company	1993	1994	1995	1996	1997	1998	1999	2000	2001	2002	2003
IN	0	0	10,705	13,983	15,659	17,895	15,670	16,229	38,799	13,227	9,848
II	498,785	483,749	443,274	389,976	346,846	312,239	276,159	259,415	0	0	0
SS	0	0	0	0	0	1,247	1,064	838	709	350	0
DN	39,745	41,668	42,399	0	0	0	0	0	0	0	0
DT	3,912	4,224	3,869	2,719	2,440	0	0	0	0	0	0
DL	24,193	19,496	20,420	20,807	22,882	0	0	0	0	0	0
CA	65,550	62,057	58,144	57,188	53,502	0	0	0	0	0	0
EI	0	0	0	0	0	0	0	78	96,112	0	392
OR	0	0	0	0	0	0	0	0	0	0	0
HU	0	0	0	0	0	0	0	0	0	0	0
PP	0	0	0	0	0	0	0	0	0	0	149,349
GN	4,578	0	0	0	0	0	0	0	0	0	0
KO	2,687	18,700	0	0	0	0	0	0	0	0	0
JN	8,104	6,126	0	0	0	0	0	0	0	0	0
IR	474,158	442,548	379,327	347,716	316,106	284,495	252,884	252,884	226,860	186,718	221,583
PA	0	0	0	0	2,203	0	0	3,569	4,353	5,567	7,394
OD	0	6,632	42,951	6,223	5,159	2,386	2,579	0	0	0	0
ED	0	0	0	116,181	155,518	0	0	0	0	0	0
CO	0	0	0	0	0	0	0	0	0	0	451,130
SP	40,196	306,091	491,917	484,394	383,152	404,754	330,918	252,461	187,975	189,802	252,891

Company	1993	1994	1995	1996	1997	1998	1999	2000	2001	2002	2003
IC + TD	2,654,081	2,644,197	2,820,168	2,954,770	2,983,047	3,000,856	2,979,759	2,926,128	2,771,750	2,529,693	2,173,679
AT	0	0	0	0	0	0	0	0	0	0	1,177
GU	0	0	0	0	0	0	0	0	59,929	87,613	0
NA	0	0	0	0	0	0	0	0	39,863	45,527	0
YG	0	0	0	0	0	0	0	0	28,879	60,724	0
IT	0	0	0	0	0	0	0	0	21,022	19,700	0
UP	0	0	0	0	0	0	0	0	9,096	0	0
NI	0	0	0	0	0	0	0	0	0	4,034	4,688
IB	0	0	0	0	0	0	0	0	9,791	0	0
RB	0	0	0	0	0	0	0	0	0	53,115	55,025
MI	0	0	0	0	0	0	0	0	0	10,149	9,793
NT	0	0	0	0	0	0	0	0	0	16,132	14,845
LP	0	0	0	0	0	0	0	0	47,115	0	0
UG	0	0	0	0	0	0	0	0	0	14,821	12,990
HI	0	0	0	0	0	0	0	0	74,627	0	0
UT	0	0	0	0	0	0	0	0	21,557	0	0
AS	0	0	0	0	0	0	0	0	16,147	0	0
GO	0	0	0	0	0	0	0	0	4,369	0	0
LE	0	0	0	0	0	0	0	0	0	56,792	44,924
GT	0	0	0	0	0	0	0	0	0	11,556	11,168
TM	0	3,729	2,515	1,784	0	0	0	0	0	0	0
GK	0	0	0	0	0	0	0	0	0	0	0
LI	30,179	0	0	0	0	0	0	0	0	0	0
UE	11,936	8,963	9,423	10,700	10,707	10,414	9,580	9,649	0	0	0
IM	17,725	16,679	16,507	15,838	11,211	10,003	9,804	11,172	0	0	0
LM	23,169	20,513	33,636	32,815	36,911	40,169	43,044	42,399	0	0	0
HL	30,003	11,994	60,227	49,949	62,747	64,734	47,200	66,990	0	0	0
UN	32,735	28,960	24,289	22,587	16,903	17,733	16,939	14,501	0	0	0
AG	24,319	11,428	17,323	14,794	23,212	19,927	22,140	17,948	0	0	0
GR	9,685	8,989	5,113	4,532	4,491	4,515	4,870	5,263	0	0	0
SK	1,846	1,437	869	547	393	1,040	0	1,996	3,748	4,209	3,499
SC	0	0	0	17,089	18,024	17,110	13,961	3,772	11,758	10,490	9,662
UA	0	0	0	5,890	6,556	21,323	72,718	191,791	216,070	272,462	283,027
SN	0	0	0	26,213	20,675	17,497	15,154	8,856	10,060	13,391	14,466
CN	20,423	21,195	20,267	21,274	23,149	22,417	22,467	21,209	21,057	23,650	24,403

Company	1993	1994	1995	1996	1997	1998	1999	2000	2001	2002	2003
LA	0	0	0	0	0	0	0	0	0	0	0
ON	0	11,007	905	11,629	16,917	15,445	12,513	0	0	0	0
SE	0	14,982	2,321	7,642	12,790	7,233	6,158	6,158	0	0	0
EK	659	1,400	6,749	4,740	3,278	3,428	2,644	2,096	2,257	1,752	1,505
HE	0	0	0	0	0	1,827	1,655	1,419	1,032	0	0
KI	0	0	0	0	0	26,987	28,019	29,319	26,256	23,172	0
PK	0	0	0	0	0	110,023	79,188	77,501	54,007	42,034	0
AB	0	0	0	0	0	47,848	48,848	47,569	53,050	52,663	0
TA	0	0	0	0	0	0	0	6,126	7,846	11,101	8,888
SU	0	0	0	0	0	0	0	0	0	0	0
LO	15,778	20,775	24,235	23,537	25,769	0	0	0	0	0	0
MA	0	0	0	0	0	9	19	17	0	0	0
KB	0	0	0	0	0	2,021	0	1,608	1,777	1,708	1,614
EL	0	0	0	0	0	0	0	916	833	1,630	773
TW	0	0	0	0	0	1,102	432	265	196	93	86
RO	5,635	9,746	11,583	109,020	19,822	20,326	20,035	21,957	23,408	20,162	17,356
SN	1,093	10,860	10,957	9,921	6,820	5,593	2,687	2,618	2,335	1,375	0
SO	0	0	0	0	0	0	0	2,601	2,386	2,074	2,031
YR	7,072	6,470	4,740	4,041	3,375	3,471	2,687	1,720	2,988	3,246	30,211
GE	0	0	0	0	0	0	2,311	5,331	13,596	23,419	21,882
RU	0	0	103,618	88,614	78,522	70,278	70,311	65,979	58,521	54,071	43,517
SA	0	0	0	0	0	0	0	0	0	0	0
OM	145,565	118,976	0	0	0	0	0	0	0	0	0
RT	10,915	8,872	29,580	8,042	6,560	5,730	5,789	1,627	6,242	6,214	7,295
IO	81,359	63,626	48,257	0	0	0	0	0	0	0	0
XI	0	0	0	0	0	0	0	0	0	1,075	0
SX	659,483	579,317	580,662	538,175	543,205	550,954	581,294	550,674	0	0	0
SM	0	0	0	0	0	0	0	0	0	0	0
BL	443,166	417,211	360,313	346,072	313,830	228,924	188,083	228,924	0	0	0
AI	0	0	0	0	0	0	0	0	0	0	0
PO	0	0	0	0	0	0	0	0	539	1,636	974
SC	0	0	0	0	0	0	0	0	0	0	0
OI	0	0	0	0	0	0	0	10,438	10,438	20,802	22,618
KL	0	0	0	0	0	0	0	0	0	0	0
AM	316,106	189,663	158,053	189,663	158,053	158,053	173,391	181,629	171,037	156,915	170,253

Company	1993	1994	1995	1996	1997	1998	1999	2000	2001	2002	2003
NN	0	0	0	0	0	0	0	0	0	0	27,136
TN	0	0	0	0	0	0	0	0	0	0	0
AN	0	0	0	0	0	0	0	0	0	0	164,707
BA	0	0	1,129	855	993	514	283	78	217	154	201
RA	0	0	0	0	0	53	687	1,217	5,495	4,890	4,246
UK	0	0	1,488	1,742	2,211	0	0	0	0	0	0
IW	0	0	2,002	2,344	878	0	0	0	0	0	0
LR	0	0	0	29,825	37,402	31,490	19,991	24,494	14,899	17,809	14,778
PD	70,857	98,179	0	0	0	0	0	0	0	0	0
GI	0	0	0	0	0	0	0	0	0	0	0
IS	88,323	73,320	56,925	0	0	0	0	0	0	0	0
UM	13,854	10,737	7,760	0	0	0	0	0	0	0	0
AC	0	0	0	0	0	0	0	141	0	0	134
ET	0	0	0	0	0	0	0	0	0	25,010	26
SR	0	0	0	0	0	0	0	0	0	136	0
SL	0	0	0	0	0	0	0	0	498,172	493,121	0
NR	0	0	0	0	0	0	0	1,068	0	1,730	7,470
IA	3,712	5,599	32,823	30,072	27,062	22,688	23,569	20,829	0	0	0
LD	0	0	0	0	0	0	0	0	0	0	0
GY	61,358	57,005	47,246	47,074	43,334	53,630	36,757	31,469	0	0	0
GB	0	0	0	0	0	7,609	37,971	44,256	0	0	0
NB	0	0	0	0	0	7	56,683	67,549	0	0	0
RE	4,267	3,993	4,224	3,533	0	2,913	2,816	0	0	0	0
YE	0	0	0	0	0	25,904	24,012	24,957	23,063	23,526	21,814
DA	0	6,063	2,166	6,986	7,093	7,116	6,617	6,642	7,179	5,471	5,510
KN	0	0	20,226	33,151	45,482	59,893	68,437	51,142	34,758	32,705	25,751
JA	0	0	9,175	9,943	7,575	12,445	31,180	33,141	29,421	27,041	27,664
EE	279,545	268,561	282,436	255,459	254,181	281,619	315,001	315,614	339,667	281,845	245,110
TE	0	0	0	0	0	0	0	0	0	0	0
DI	0	6,051	5,288	0	0	0	0	0	0	0	0
CI	304,243	290,722	380,766	371,361	343,783	354,617	278,621	238,596	217,424	216,886	203,882
OV	104,574	158,097	160,279	160,139	168,522	158,849	188,298	164,438	142,943	86,952	119,406
EN	0	0	0	0	0	1,237	1,068	0	0	0	0

Source: own calculations

G2. GHG Emission (tons CO₂ equivalent) based on API Compendium, according to gas flaring

Formula and example are discussed in Chapter 3.

	1990	1991	1992	1993	1996	1997	1998	1999	2000	2001	2002	2003
Indonesia	11,819,604	14,386,810	15,409,644	14,949,800	12,169,786	10,271,321	9,475,082	8,694,497	7,042,928	8,856,619	8,229,733	10,322,000

Source: own calculations

Company	1996	1997	1998	1999	2000	2001	2002	2003
AM	0	0	0	0	0	0	317165	2565301
AV	0	0	0	0	0	921958	1013035	1528150
GJ	0	0	0	0	0	0	979036	1124501
MU	257601	320914	335351	387279	484356	742730	1029383	926251
EE	337388	441131	386169	622253	538789	491991	787303	661798
CO	0	0	0	0	0	0	1119008	660917
PS	0	0	0	0	0	0	374188	423219
BN	0	0	0	0	0	0	342164	381837
MS	0	0	0	0	0	0	354905	308439
LR	830025	1405789	795121	952872	690695	682600	350800	288861
NU	0	0	0	0	0	0	143055	220236
CI	122014	526341	1162005	965888	516647	538922	399566	214517
IC+TD	746899	859267	711118	732388	423198	379082	220062	207591
AA	0	0	0	0	0	188101	124504	181374
OE	26962	85074	29963	28073	63366	23959	134931	179512
GH	0	0	0	0	0	0	173301	153482
NM	2104603	514910	520292	405930	323083	331880	157700	65513
RU	65719	51696	59742	59846	51540	49755	44994	59458
LK	107143	110869	66368	45410	30921	23340	24272	42901
OW	0	0	0	0	0	0	0	40648
EK	0	5770	3338	2174	2846	2303	1837	20104
OV	133976	185969	255015	203557	112348	54419	35837	18752
NE	0	0	0	0	0	22168	34919	17914
AD	0	0	0	0	0	0	51153	8436
DS	0	0	0	0	0	0	0	7917
DE	0	0	0	0	0	0	0	6365
AT	0	0	0	0	0	0	5563	4399

Company	1996	1997	1998	1999	2000	2001	2002	2003
GA	0	0	0	0	0	0	2976	2070
GK	22304	3571	1760	648	907	1217	1321	1347
LB	0	0	0	0	82	329031	102	110
SA	0	0	0	621	492	389	79	81
BA	18888	11048	11462	1656	5123	8357	6572	0
GU	0	0	0	0	0	1151920	0	0
SX	1090623	1361261	1329023	973624	968191	1129047	0	0
PK	0	1767347	1119240	999291	852329	708861	0	0
OC	660994	575223	512557	428829	497447	340865	0	0
AB	0	268959	314548	253280	214495	272219	0	0
IT	0	0	0	0	0	173896	0	0
KI	0	251676	138298	272211	119713	115262	0	0
NA	0	0	0	0	0	101476	0	0
YG	0	0	0	0	0	47013	0	0
SN	1	27143	30144	27168	28514	19949	0	0
SS	0	4218	363	7659	1009	2872	0	0
HE	0	12704	12600	12264	11514	1035	0	0
II	943981	924420	780996	545678	0	0	0	0
IN	127887	82248	33838	42947	23850	0	0	0
DT	13247	0	0	0	0	0	0	0
SV	213047	0	0	0	0	0	0	0
DL	340137	0	0	0	0	0	0	0
JW	0	0	0	0	467437	0	0	0
OK	0	0	0	0	0	0	0	0
ED	1960545	0	0	0	0	0	0	0
SE	214932	164763	213198	54464	0	0	0	0
SO	0	0	0	0	0	0	0	0
BL	1779457	25925	169	145	0	0	0	0
GY	51413	27894	45850	77285	53249	0	0	0
GB	0	57750	344170	320652	320085	0	0	0
IA	1	197027	189990	163624	161710	0	0	0
NB	0	0	71437	106289	78992	0	0	0
RE	0	414	957	492	0	0	0	0

Source: own calculations

G3. GHG Emission (tons CO₂ equivalent) based on CAPP Guide, according to gas flaring

Formula and example are discussed in Chapter 3.

	1990	1991	1992	1993	1996	1997	1998	1999	2000	2001	2002	2003
Indonesia	11,850,525	14,424,701	15,450,238	14,989,155	12,201,696	10,298,169	9,499,841	10,506,694	8,846,377	11,259,025	8,251,153	10,348,938

Source: own calculations

Company	1996	1997	1998	1999	2000	2001	2002	2003
SS	0	4,229	363	7,679	1,012	2,880	0	0
II	946,459	926,846	783,047	547,100	0	0	0	0
IN	128,208	82,445	33,907	43,039	23,893	0	0	0
DT	13,283	0	0	0	0	0	0	0
SV	213,610	0	0	0	0	0	0	0
DL	341,040	0	0	0	0	0	0	0
NE	0	0	0	0	0	22,207	34,996	17,952
JW	0	0	0	0	468,650	0	0	0
AV	0	0	0	0	0	924,382	1,015,699	1,532,187
OK	0	0	0	0	0	0	0	0
ED	1,965,764	0	0	0	0	0	0	0
CO	0	0	0	0	0	0	1,121,985	662,674
OC	662,752	576,753	513,920	429,970	498,770	341,766	0	0
PS	0	0	0	0	0	0	375,180	424,341
BN	0	0	0	0	0	0	343,063	382,833
MS	0	0	0	0	0	0	355,827	309,234
AT	0	0	0	0	0	0	5,578	4,410
IC + TD	748,881	861,549	713,002	734,327	424,315	380,083	220,641	208,136
GU	0	0	0	0	0	1,154,984	0	0
YG	0	0	0	0	0	47,137	0	0
IT	0	0	0	0	0	174,359	0	0
NA	0	0	0	0	0	101,746	0	0
GK	22,362	3,580	1,764	649	908	1,219	1,323	1,349
LK	107,428	111,163	66,542	45,529	31,001	23,400	24,334	43,013
GA	0	0	0	0	0	0	2,983	2,075
MU	258,283	321,764	336,240	388,307	485,643	744,704	1,032,121	928,714
LB	0	0	0	0	0	329,858	0	0

Company	1996	1997	1998	1999	2000	2001	2002	2003
SE	215,504	165,202	213,766	54,609	0	0	0	0
EK	0	5,785	3,347	2,179	2,854	2,309	1,842	20,157
HE	0	12,738	12,634	12,297	11,544	1,038	0	0
KI	0	252,342	138,662	272,915	120,010	115,548	0	0
PK	0	1,772,051	1,122,219	1,001,949	854,596	710,745	0	0
AB	0	269,672	315,382	253,951	215,063	272,941	0	0
AA	0	0	0	0	0	188,602	124,835	181,857
SN	0	27,214	30,223	27,240	28,589	20,002	0	0
SO	0	0	0	0	0	0	0	0
OE	27,032	85,299	30,041	28,148	63,533	24,023	135,290	179,989
RU	65,894	51,833	59,901	60,005	51,677	49,887	45,114	59,616
DS	0	0	0	0	0	0	0	7,938
SX	1,093,526	1,364,884	1,332,560	976,215	970,767	1,132,051	0	0
BL	1,783,985	25,787	0	0	0	0	0	0
SA	0	0	0	623	493	389	78	78
AM	0	0	0	0	0	0	318,003	2,572,091
BA	18,938	11,077	11,493	1,660	5,137	8,379	6,589	0
DE	0	0	0	0	0	0	0	6,382
AD	0	0	0	0	0	0	51,288	8,457
GJ	0	0	0	0	0	0	981,637	1,127,485
GH	0	0	0	0	0	0	173,763	153,891
NU	0	0	0	0	0	0	143,436	220,822
LR	832,234	1,409,531	797,238	955,409	692,534	684,414	351,728	289,622
GY	51,548	27,966	45,970	77,490	53,390	0	0	0
GB	0	57,904	345,087	321,505	320,934	0	0	0
IA	0	197,552	190,495	164,060	162,140	0	0	0
NB	0	0	71,627	106,572	79,202	0	0	0
RE	0	415	960	493	0	0	0	0
NM	2,110,211	516,281	521,677	407,011	323,943	332,764	158,119	65,686
EE	338,212	442,215	387,087	623,786	540,070	493,140	789,247	663,400
CI	122,319	527,721	1,165,076	968,432	517,993	540,329	400,603	215,063
OW	0	0	0	0	0	0	0	40,756
OV	134,226	186,371	255,611	204,011	112,564	54,479	35,852	18,730

Source: own calculations

Appendix H: Gas-to-Oil Ratio

Formula and example are discussed in Chapter 3.

Company	1993	1994	1995	1996	1997	1998	1999	2000	2001	2002	2003
II	293	327	284	276	425	295	360	595	N/A	N/A	N/A
DN	256	719	415	N/A	N/A	N/A	N/A	N/A	N/A	N/A	N/A
DT	157	247	183	166	185	N/A	N/A	N/A	N/A	N/A	N/A
DL	1,030	1,176	801	2,353	193	N/A	N/A	N/A	N/A	N/A	N/A
CA	300	381	237	100	108	N/A	N/A	N/A	N/A	N/A	N/A
OR	N/A	N/A	N/A	N/A	N/A	N/A	N/A	N/A	N/A	N/A	N/A
HU	N/A	N/A	N/A	N/A	N/A	N/A	N/A	N/A	N/A	N/A	N/A
GN	3,512	N/A	N/A	N/A	N/A	N/A	N/A	N/A	N/A	N/A	N/A
KO	113	232	N/A	N/A	N/A	N/A	N/A	N/A	N/A	N/A	N/A
JN	153	228	N/A	N/A	N/A	N/A	N/A	N/A	N/A	N/A	N/A
OD	N/A	535	120	529	757	1,321	609	N/A	N/A	N/A	N/A
ED	N/A	N/A	N/A	303	454	N/A	N/A	N/A	N/A	N/A	N/A
TM	N/A	3,182	3,806	5,687	N/A	N/A	N/A	N/A	N/A	N/A	N/A
GK	N/A	N/A	N/A	N/A	N/A	N/A	N/A	N/A	N/A	N/A	N/A
LI	105	N/A	N/A	N/A	N/A	N/A	N/A	N/A	N/A	N/A	N/A
UE	0	0	0	0	0	0	0	0	N/A	N/A	N/A
IM	27	15	29	22	76	94	152	162	N/A	N/A	N/A
LM	454	571	542	557	592	560	596	530	N/A	N/A	N/A
HL	1,345	3,185	831	1,042	1,048	871	473	877	N/A	N/A	N/A
UN	703	710	701	705	891	777	921	809	N/A	N/A	N/A
AG	121	114	261	322	234	178	137	260	N/A	N/A	N/A
GR	0	0	0	0	180	0	0	0	N/A	N/A	N/A
LA	N/A	N/A	N/A	N/A	N/A	N/A	N/A	N/A	N/A	N/A	N/A
ON	N/A	43	0	134	154	27	244	N/A	N/A	N/A	N/A
SE	N/A	104	412	228	434	615	0	0	N/A	N/A	N/A
SU	N/A	N/A	N/A	N/A	N/A	N/A	N/A	N/A	N/A	N/A	N/A
LO	253	266	253	0	0	N/A	N/A	N/A	N/A	N/A	N/A
MA	N/A	N/A	N/A	N/A	N/A	0	0	0	N/A	N/A	N/A
SA	N/A	N/A	N/A	N/A	N/A	N/A	N/A	N/A	N/A	N/A	N/A
OM	29	36	N/A	N/A	N/A	N/A	N/A	N/A	N/A	N/A	N/A
IO	329	358	109	N/A	N/A	N/A	N/A	N/A	N/A	N/A	N/A
SX	52	59	54	57	70	84	87	81	N/A	N/A	N/A
SM	N/A	N/A	N/A	N/A	N/A	N/A	N/A	N/A	N/A	N/A	N/A
BL	0	0	0	0	0	0	0	0	N/A	N/A	N/A
AI	N/A	N/A	N/A	N/A	N/A	N/A	N/A	N/A	N/A	N/A	N/A
SC	N/A	N/A	N/A	N/A	N/A	N/A	N/A	N/A	N/A	N/A	N/A
KL	N/A	N/A	N/A	N/A	N/A	N/A	N/A	N/A	N/A	N/A	N/A
TN	N/A	N/A	N/A	N/A	N/A	N/A	N/A	N/A	N/A	N/A	N/A
UK	N/A	N/A	0	0	0	N/A	N/A	N/A	N/A	N/A	N/A
IW	N/A	N/A	0	0	0	N/A	N/A	N/A	N/A	N/A	N/A
PD	586	561	N/A	N/A	N/A	N/A	N/A	N/A	N/A	N/A	N/A
GI	N/A	N/A	N/A	N/A	N/A	N/A	N/A	N/A	N/A	N/A	N/A
IS	134	156	152	N/A	N/A	N/A	N/A	N/A	N/A	N/A	N/A
UM	200	31	248	N/A	N/A	N/A	N/A	N/A	N/A	N/A	N/A
IA	0	125	134	190	268	249	218	216	N/A	N/A	N/A
LD	N/A	N/A	N/A	N/A	N/A	N/A	N/A	N/A	N/A	N/A	N/A
GY	63	118	78	28	22	19	29	23	N/A	N/A	N/A
GB	N/A	N/A	N/A	N/A	N/A	201	245	361	N/A	N/A	N/A
NB	N/A	N/A	N/A	N/A	N/A	0	34	43	N/A	N/A	N/A
RE	0	0	0	0	N/A	0	0	N/A	N/A	N/A	N/A

TE	N/A	N/A	N/A	N/A	N/A	N/A	N/A	N/A	N/A	N/A	N/A
DI	N/A	0	0	N/A	N/A	N/A	N/A	N/A	N/A	N/A	N/A
Company	1993	1994	1995	1996	1997	1998	1999	2000	2001	2002	2003
EN	N/A	N/A	N/A	N/A	N/A	0	0	N/A	N/A	N/A	N/A
UT	N/A	N/A	N/A	N/A	N/A	N/A	N/A	N/A	919	N/A	N/A
HI	N/A	N/A	N/A	N/A	N/A	N/A	N/A	N/A	884	N/A	N/A
LP	N/A	N/A	N/A	N/A	N/A	N/A	N/A	N/A	497	N/A	N/A
IB	N/A	N/A	N/A	N/A	N/A	N/A	N/A	N/A	468	N/A	N/A
AS	N/A	N/A	N/A	N/A	N/A	N/A	N/A	N/A	230	N/A	N/A
GO	N/A	N/A	N/A	N/A	N/A	N/A	N/A	N/A	162	N/A	N/A
HE	N/A	N/A	N/A	N/A	N/A	247	264	275	11	N/A	N/A
UP	N/A	N/A	N/A	N/A	N/A	N/A	N/A	N/A	0	N/A	N/A
SN	438	659	733	1,294	1,734	1,976	3,737	3,669	3,229	4,795	N/A
SS	N/A	N/A	N/A	N/A	N/A	4,760	5,217	5,252	4,857	2,673	N/A
YG	N/A	N/A	N/A	N/A	N/A	N/A	N/A	N/A	159	2,451	N/A
GU	N/A	N/A	N/A	N/A	N/A	N/A	N/A	N/A	613	727	N/A
PK	N/A	N/A	N/A	N/A	N/A	547	427	0	519	624	N/A
KI	N/A	N/A	N/A	N/A	N/A	343	176	573	621	378	N/A
IT	N/A	N/A	N/A	N/A	N/A	N/A	N/A	N/A	182	247	N/A
AB	N/A	N/A	N/A	N/A	N/A	259	226	202	166	153	N/A
SL	N/A	N/A	N/A	N/A	N/A	N/A	N/A	N/A	96	105	N/A
NA	N/A	N/A	N/A	N/A	N/A	N/A	N/A	N/A	58	59	N/A
XI	N/A	N/A	N/A	N/A	N/A	N/A	N/A	N/A	N/A	0	N/A
SR	N/A	N/A	N/A	N/A	N/A	N/A	N/A	N/A	N/A	0	N/A
AT	N/A	N/A	N/A	N/A	N/A	N/A	N/A	N/A	N/A	N/A	3,416
OV	3,756	1,696	404	414	321	448	317	1,617	1,820	2,609	2,400
EK	0	0	79	64	0	911	2,071	2,248	1,815	1,978	1,939
LE	N/A	N/A	N/A	N/A	N/A	N/A	N/A	N/A	N/A	1,687	1,630
UG	N/A	N/A	N/A	N/A	N/A	N/A	N/A	N/A	N/A	1,837	1,101
LR	N/A	N/A	N/A	672	528	1,000	642	946	1,076	1,233	1,066
CI	423	206	404	425	429	448	518	823	619	700	973
SN	N/A	N/A	N/A	258	342	533	1,041	1,535	1,342	952	895
BA	N/A	N/A	478	405	515	581	818	3,012	0	3,217	846
RB	N/A	N/A	N/A	N/A	N/A	N/A	N/A	N/A	N/A	409	560
IR	0	0	0	0	0	0	0	0	724	439	458
OI	N/A	N/A	N/A	N/A	N/A	N/A	N/A	299	299	325	333
TA	N/A	N/A	N/A	N/A	N/A	N/A	N/A	337	205	145	308
KN	N/A	N/A	132	114	160	241	215	414	277	294	290
EE	397	464	421	501	364	359	244	254	218	256	266
AN	N/A	N/A	N/A	N/A	N/A	N/A	N/A	N/A	N/A	N/A	259
NT	N/A	N/A	N/A	N/A	N/A	N/A	N/A	N/A	N/A	176	251
SP	295	91	65	71	50	47	57	61	92	74	242
YR	188	105	132	284	170	165	214	334	192	0	205
RU	N/A	N/A	43	49	59	51	59	59	67	66	106
UA	N/A	N/A	N/A	208	110	80	59	32	49	60	90
SK	0	23	0	0	0	105	N/A	234	219	95	90
GT	N/A	N/A	N/A	N/A	N/A	N/A	N/A	N/A	N/A	400	64
CN	0	16	28	32	50	77	139	117	38	40	40
RA	N/A	N/A	N/A	N/A	N/A	0	0	6	10	18	26
PO	N/A	N/A	N/A	N/A	N/A	N/A	N/A	N/A	21	744	22
IC + TD	19	22	8	13	24	14	29	7	10	6	13
SC	N/A	N/A	N/A	12	12	11	10	7	9	11	9
JA	N/A	N/A	0	0	0	0	0	0	0	0	0
PP	N/A	N/A	N/A	N/A	N/A	N/A	N/A	N/A	N/A	N/A	0
CO	N/A	N/A	N/A	N/A	N/A	N/A	N/A	N/A	N/A	N/A	0
NN	N/A	N/A	N/A	N/A	N/A	N/A	N/A	N/A	N/A	N/A	0

AC	N/A	N/A	N/A	N/A	N/A	N/A	N/A	0	N/A	N/A	0
EI	N/A	N/A	N/A	N/A	N/A	N/A	N/A	0	0	N/A	0
YE	N/A	N/A	N/A	N/A	N/A	0	0	0	0	14,179	0
NI	N/A	N/A	N/A	N/A	N/A	N/A	N/A	N/A	N/A	0	0
Company	1993	1994	1995	1996	1997	1998	1999	2000	2001	2002	2003
MI	N/A	N/A	N/A	N/A	N/A	N/A	N/A	N/A	N/A	0	0
ET	N/A	N/A	N/A	N/A	N/A	N/A	N/A	N/A	N/A	0	0
NR	N/A	N/A	N/A	N/A	N/A	N/A	N/A	0	N/A	0	0
GE	N/A	N/A	N/A	N/A	N/A	N/A	994	431	620	0	0
IN	N/A	N/A	0	0	0	0	0	0	0	0	0
PA	N/A	N/A	N/A	N/A	0	N/A	N/A	0	0	0	0
KB	N/A	N/A	N/A	N/A	N/A	0	N/A	0	0	0	0
EL	N/A	N/A	N/A	N/A	N/A	N/A	N/A	0	0	0	0
TW	N/A	N/A	N/A	N/A	N/A	0	0	0	0	0	0
RO	10	0	0	0	0	0	0	0	0	0	0
SO	N/A	N/A	N/A	N/A	N/A	N/A	N/A	0	0	0	0
RT	0	0	0	0	0	0	0	0	0	0	0
AM	0	0	0	0	0	0	0	0	0	0	0
DA	N/A	87	194	0	0	0	0	0	0	0	0

Source: own calculations

References

Asian Development Bank: Asia Least – Cost Greenhouse Gas Abatement Strategy Project (ALGAS) Indonesia. 1998

Baiquni, H.: Indonesia's SD Criteria & Indicators and DNA for CDM Projects. Presentation at *Skill share Workshop - Regional Institutional Capacity Building in the Implementation of CDM in ASEAN Member Countries*. ASEAN Secretariat, Jakarta, 18-19 March, 2004

Baker Hughes: Electric Submersible Pump. 2004
http://www.bakerhughes.com/bot/completions/packers/systems_esp.htm, viewed on October 20, 2004

Barber, T.R., Sackett, W.M.: Anthropogenic Fossil Carbon Sources of Atmospheric Methane. In Geyer, R.A. (ed.): *A Global Warming Forum – Scientific, Economic and Legal Overview*, pp 213 – 218. CRC Press. Boca Raton. 1993

Barreiro, E.: e-mail comment by Eduardo Barreiro from the Argentine Institute for Oil and Gas – IAPG in October 2004

Begg, D., Fischer, S., Dornbusch, R.: *Economics*. McGraw – Hill. Berkshire. 2003

Belguedj, M.: Africa Gas Initiative Main Report Volume I. UNDP and World Bank ESMAP. 2001

Bosi, M.: IEA's Work on Assessing Emission Reductions in the Natural Gas Sector through Project-Based Mechanisms. Presentation at *IPIECA Workshop on Reporting, CDM and JI* in Lillehammer, March 16, 2004

Bouille, D.H., Girardin, L.O., Sbroiavacca, N.D.: Argentina. In *Confronting Climate Change – Economic Priorities and Climate Protection in Developing Nations*. National Environmental Trust. Washington, D.C. 2000

BPMIGAS: Global Gas Flaring Reduction - In Practices of Indonesian Flaring Reduction in Oil and Gas Business. Presentation at *Global Gas Flaring Reduction's Regulatory Capacity Building Workshop* in Bandung, Indonesia, March 15 – 16, 2004

Canadian Association of Petroleum Producers: Guide Calculating Greenhouse Gas Emissions. CAPP. 2003

Canadian Association of Petroleum Producers: Guide Estimation of Flaring and Venting Volumes from Upstream Oil and Gas Facilities. CAPP. 2002

Central Intelligence Agency: The World Fact Book – Indonesia. 2004
<http://www.cia.gov/cia/publications/factbook/geos/id.html>, viewed on October 13, 2004

- Chemlink Pty Ltd: Gas to liquids. 1997
<http://www.chemlink.com.au/gtl.htm>, viewed on October 26, 2004
- ChevronTexaco: Major Sanha Lift Completed Safely and On Schedule. April 02, 2004
http://www.chevrontexaco.com/news/spotlight/2004-04-02_sanha.asp, viewed on October 27, 2004
- Chrisandini: Persetujuan Nasional untuk Proyek CDM. Presentation at *CDM Training* in Jakarta, July 21, 2004
- Cline, W.R.: The Economics of Global Warming. Institute for International Economics. Washington, DC. 1992
- CO2e: Glossary. 2002
<http://www.co2e.com/common/glossary.asp>, viewed on April 5, 2004
- Dudek, D., Wiener, J.: Joint Implementation, transaction costs and climate change, OCDE/GD(96)173, Paris. 1996
<http://www.oecd.org/dataoecd/17/33/2392058.pdf>, viewed on September 19, 2004
- Dutschke, M., Michaelowa, A.: Development Aid and the CDM – How to interpret “Financial Additionality”. HWWA Discussion Paper No. 228. 2003
- Embassy of the United States of America in Indonesia: Indonesia 2003 Oil Production Drops 8 Percent. In *Energy News*. April 15, 2004a
<http://www.usembassyjakarta.org/econ/oil-2003-drop.html>, viewed on June 20, 2004
- Embassy of the United States of America in Indonesia: Indonesia’s Natural Gas Opportunities and Challenges. In *Energy News*. June 23, 2004b
<http://www.usembassyjakarta.org/download/Natural%20Gas%202003.pdf>, viewed on October 16, 2004
- Embassy of the United States of America in Indonesia: Petroleum Report Indonesia 2002 – 2003. Jakarta. 2004c
<http://jakarta.usembassy.gov/econ/petro2003-toc.html>, viewed on June 20, 2004
- Energy Information Administration: Annual Energy Outlook 2004 with Projections to 2025. U.S. Department of Energy, January 2004a
[http://www.eia.doe.gov/oiaf/aeo/pdf/0383\(2004\).pdf](http://www.eia.doe.gov/oiaf/aeo/pdf/0383(2004).pdf), viewed on July 7, 2004
- Energy Information Administration: Indonesia Country Analysis Brief. 2004b
<http://www.eia.doe.gov/emeu/cabs/indonesia.html>, viewed on October 7, 2004
- Energy Information Administration: International Carbon Dioxide Emissions from the Consumption and Flaring of Natural Gas Data. 2003a
<http://www.eia.doe.gov/emeu/international/gas.html#IntlCarbon>, viewed on July 7, 2004

- Energy Information Administration: International Energy Outlook 2004. U.S. Department of Energy, April 2004c
[http://www.eia.doe.gov/oiaf/ieo/pdf/0484\(2004\).pdf](http://www.eia.doe.gov/oiaf/ieo/pdf/0484(2004).pdf), viewed on July 7, 2004
- Energy Information Administration: International Energy Annual 2002. U.S. Department of Energy, June 2004d
<http://www.eia.doe.gov/emeu/iea/carbon.html>, viewed on July 7, 2004
- Energy Information Administration: West African Gas Pipeline (WAGP) Project. U.S. Department of Energy, March 2003b
<http://www.eia.doe.gov/emeu/cabs/wagp.html>, viewed on October 26, 2004
- Flare Research Project of University of Alberta: Flaring Facts. University of Alberta, Canada. 2004
<http://www.mece.ualberta.ca/groups/combustion/flare/>, viewed on July 7, 2004
- Gerner, F.: A Framework for Reducing Gas Flaring and Venting. Presentation at *Global Gas Flaring Reduction's Regulatory Capacity Building Workshop* in Bandung, Indonesia, March 15 – 16, 2004
- Grütter, J.M., Kappel, R., Staub, P.: The Potential GHG Market in Asia. World Bank. 2002
- Hanle, L.: General Guidelines and Principles for Projects to Reduce/Eliminate Flaring. Presentation at *Workshop – Global Gas Flaring Reduction Partnership* in London, July 1, 2003
- Haugland, T.: Baseline Methodologies for Flare Reduction Projects – An Overview. Presentation at *IPIECA Workshop on Reporting, CDM and JI* in Lillehammer, March 16, 2004
- Haugland, T.: Overview of Carbon Crediting for Flaring Reductions Activities. Presentation at *Workshop – Global Gas Flaring Reduction Partnership* in London, July 1, 2003
- Houghton, J. et al. (ed.): Climate Change 2001 – The Scientific Basis. The Intergovernmental Panel on Climate Change (IPCC). 2001
http://www.grida.no/climate/ipcc_tar/wg1/index.htm, viewed on July 8, 2004
- Houghton, J.: Global Warming – The Complete Briefing, 3rd Edition. Cambridge University Press. Cambridge. 2004
- Huq, S.: Applying Sustainable Development Criteria to CDM Projects – PCF Experience. *PCFplus* Report 10. Washington DC. 2002
http://www.iied.org/docs/climate/cc_PCF.pdf, viewed on September 21, 2004
- IPCC: Good Practice Guidance and Uncertainty Management in National Greenhouse Gas Inventories. 2000

http://www.ipcc-nggip.iges.or.jp/public/gp/english/2_Energy.pdf, viewed on July 25, 2004

Jahn, F., Cook, M., Graham, M.: Hydrocarbon Exploration and Production. Elsevier Science B.V. Amsterdam. 2001

Jahn, M., Michaelowa, A., Raubenheimer S., Liptow, H.: Measuring the Potential of the Unilateral CDM – A Pilot Study. HWWA Discussion Paper No. 263. Hamburgisches Welt – Wirtschafts – Archiv (HWWA). Hamburg. 2004

Jepma, C.J.: Complicated Additionality. In Joint Implementation Quarterly, Vol. 10 No. 1. 2004

Jones, J.C.: Hydrocarbon Process Safety. Whittles Publishing. Caithness. 2003

Kaldany, R.: Global Gas Flaring Reduction Initiative. Presentation at Marrakech, Nov. 8, 2001

Khalil, M.A.K.: Atmospheric Trace Gases – Sources, Sinks, and Role in Global Change. In Geyer, R.A. (ed.): *A Global Warming Forum – Scientific, Economic and Legal Overview*, pp 359 – 361 . CRC Press. Boca Raton. 1993

Kim, J.A.: Sustainable Development and the Clean Development Mechanism – A South African Case Study. *Journal of Environment & Development*, Vol. 13, No. 3, September 2004 pp. 201-219

<http://jed.sagepub.com/cgi/reprint/13/3/201>, viewed on September 21, 2004

Kostiuk, L., Johnson, M., Thomas, G.: Flare Research Project – Final Report, November 1996 – September 2004. University of Alberta, Canada. 2004

<http://www.mece.ualberta.ca/groups/combustion/flare/papers/Final%20Report2004.pdf>, viewed on September 28, 2004

Langrock, T., Michaelowa, A., Greiner, S.: Defining Investment Additionality for CDM Projects – Practical Approaches. HWWA Discussion Paper no. 106. 2000

http://www.hwwa.de/Publikationen/Discussion_Paper/2000/106.pdf, viewed on October 25, 2004

Lawal, Y.: NNPC signs N171 trillion loan pact with three banks. In *Guardian News Nigeria*, September 20, 2004

<http://www.guardiannewsngr.com/news/article03/200904>, viewed on October 25, 2004

Lecocq, F., Capoor, K.: State and Trends of the Carbon Market 2003. PCF plus Research, World Bank. Washington DC. 2003

<http://www.pointcarbon.com/wimages/StateandTrendsofCarbonMarket2003.pdf>, viewed on May 17, 2004

Lecocq, F.: State and Trends of the Carbon Market 2004. PCF plus Research, World Bank. Washington DC. 2004

<http://www.pointcarbon.com/wimages/CarbonMarketStudy2004.pdf> , viewed on October 27, 2004

Lee, M. (ed.): CDM Information and Guidebook. Unep Risø Centre. Roskilde. 2004
<http://www.cd4cdm.org/Publications/cdm%20guideline%202nd%20edition.pdf>, viewed on October 10, 2004

Legowo, E., Witolo, M.: Energy Sector's Potential on the CDM. Presentation at *Workshop on Clean Development Mechanism – Prospect and Commitment*. Jakarta. 2003

Lopez, I.V. (coord.): The Clean Development Mechanism (CDM) – A Brazilian Implementation Guide. Fundação Getulio Vargas. Rio de Janeiro. 2002

MBendi Information Services: Nigeria - Oil And Gas Industry. 2000
http://www.mbendi.co.za/indy/oil/gas_/af/ng/p0005.htm#10, viewed on October 25, 2004

Michaelowa, A.: Baseline methodologies for the CDM – which road to take? Presentation at Institute of Global Environment and Society (IGES), 23 June 1999
http://www.ghgprotocol.org/docs/Axel_Baseline.pdf, viewed on October 26, 2004

Michaelowa, A., Jung, M.: Consistency of additionality determination and the Executive Board's decisions. Presentation at *COP 9 Side Event – Constructive dispute over different additionality concepts of CDM*. Milan, December 6, 2003

Michaelowa, A., Stronzik, M.: Transaction cost of the Kyoto Mechanisms. HWWA Discussion Paper No. 175. 2002

Michaels, P.J., Balling, R.C.: Climate History during the Recent Greenhouse Enhancement. In Geyer, R.A. (ed.): *A Global Warming Forum – Scientific, Economic and Legal Overview*, pp 298 – 300. CRC Press. Boca Raton. 1993

Ministerium für Umwelt und Verkehr Baden – Württemberg: Flexible Instrumente im Klimaschutz – Emissionsrechthandel, Joint Implementation, Clean Development Mechanism. Reichert GmbH. Stuttgart. 2003

Murdiyarso, D.: CDM: Mekanisme Pembangunan Bersih. Penerbit Buku Kompas. Jakarta. 2003a

Murdiyarso, D.: Protokol Kyoto, Implikasinya bagi Negara Berkembang. Penerbit Buku Kompas. Jakarta. 2003b

Murdiyarso, D.: Sepuluh Tahun Perjalanan Negosiasi Konvensi Perubahan Iklim. Penerbit Buku Kompas. Jakarta. 2003c

Newell, D.: Flare Reduction and CDM Development in Indonesia - The Yakin Flare/Vent Reduction Project. Presentation at *Global Gas Flaring Reduction's Regulatory Capacity Building Workshop* in Bandung, Indonesia, March 15 – 16, 2004

Newton, D.E.: Global Warming – A Reference Handbook. ABC – CLIO. Santa Barbara. 1993

Organisation for Economic Co-operation and Development (OECD): Global Warming – The Benefits of Emission Abatement. OECD. Paris. 1992

Paradowski, H., Barthe, L., Gabelle, D.: Increasing the capacity of NGL recovery units. Gas Processing Department, Process Division - Technip France. Heidelberg. 2003
http://www.gasprocessors.com/GlobalDocuments/E03Sep_3.pdf, viewed on October 25, 2004

Point Carbon: Annex I Parties' current and potential CER Demand. 2003
http://www.pointcarbon.com/wimages/Report_ADB_IETA.pdf, viewed on May 17, 2004

Point Carbon: Market comment. In CDM & JI Monitor, October 26, 2004.
https://pointcarbon.com/wimages/CJM_26_10_2004_2.pdf, viewed on October 27, 2004

Priambodo, Architrandi: Clean Development Mechanism in Indonesia – Critical factors for CDM project development. Presentation at *Global Gas Flaring Reduction's Regulatory Capacity Building Workshop* in Bandung, Indonesia, March 15 – 16, 2004

PriceWaterhouseCoopers: A Business View on Key Issues Relating to Kyoto Mechanisms, London. 2000
[http://www.pwc.com/extweb/manissue.nsf/2e7e9636c6b92859852565e00073d2fd/645ca72d5e87460480256b220052fb99/\\$FILE/Kyoto%20Mechanisms.pdf](http://www.pwc.com/extweb/manissue.nsf/2e7e9636c6b92859852565e00073d2fd/645ca72d5e87460480256b220052fb99/$FILE/Kyoto%20Mechanisms.pdf), viewed on September 19, 2004

Sari, A.P.: Gas-Flaring and CDM – Experience from Indonesia. Presentation at *CDM and Gas Flaring Reduction – Significant Potential towards GHG Commitments*. CarbonExpo, Cologne. June 11, 2004

Sari, A.P., Purnomo, A., Soejachmoen, M.H., Chrisandini: Progress of the Designation of the Indonesian CDM Authority. Presentation at *Global Gas Flaring Reduction's Regulatory Capacity Building Workshop* in Bandung, Indonesia, March 15 – 16, 2004

Schelling, T.C.: Some Economics of Global Warming. In Dorfman, R., Dorfman, N.S. (eds.): *Economics of the Environment – Selected Readings*. W.W. Norton & Company. New York. 1993

Schubert, P., LeViness, S., Arcuri, K., Stranges, A.: Development of the Modern Fischer – Tropsch Process (1958 – 1999). 2001
http://www.fischer-tropsch.org/primary_documents/presentations/acs2001_chicago/chic_slide03.htm, viewed on October 26, 2004

Shell Global Solutions: Glossary of Terms.
http://www.shellglobalsolutions.com/base_oils/glossary/a_g.htm, viewed on September 28, 2004

Shinn, J.H.: Example Potential CDM Projects and Complications: Gas Reinjection and Utilization. Presentation at *IPIECA Workshop on Reporting, CDM and JI* in Lillehammer, March 16, 2004

Shires, T.M., Loughran, C.J.: Compendium of Greenhouse Gas Emissions Estimation Methodologies for the Oil and Gas Industry. American Petroleum Institute. 2004

Sinha, C.S.: Carbon Finance at the World Bank. Presentation at *CDM and Gas Flaring Reduction – Significant Potential towards GHG Commitments*. CarbonExpo, Cologne. June 11, 2004

Solow, R.M.: Sustainability – An Economist’s Perspective. In Dorfman, R., Dorfman, N.S. (eds.): *Economics of the Environment – Selected Readings*. W.W. Norton & Company. New York. 1993

Spalding-Fecher, R.: A financial analysis of a potential CDM project in South Africa. Energy & Development Research Centre. Cape Town. 2002
<http://www.ghgprotocol.org/docs/Pilot%20CDM%20analysis-wind-final.pdf>, viewed on October 17, 2004

State Ministry for Environment, Republic of Indonesia (SME – ROI): Agenda 21 Indonesia - Strategi Nasional untuk Pembangunan Berkelanjutan. Jakarta. 1997

State Ministry for Environment, Republic of Indonesia: Indonesia – The First National Communication under UNFCCC. Jakarta. 1999

State Ministry for Environment, Republic of Indonesia: National Strategy Study on the Clean Development Mechanism in Indonesia. Jakarta. 2001

Suárez, C.E.: Argentina’s Ongoing Efforts to Lower Greenhouse Gas Emissions. In *Promoting Development While Limiting Greenhouse Gas Emissions – Trends and Baselines*. UNDP & WRI. New York. 1999.

Sutter, C.: Additionality of CDM – Are We on the Right Track? Presentation at *CoP-9 Side Event*, December 5, 2003

Sutter, C.: Current status of the CDM and its implications for gas flaring. Presentation at *Global Gas Flaring Reduction’s Regulatory Capacity Building Workshop* in Bandung, Indonesia, March 15 – 16, 2004.

Tanujaya, O.: Peluang Pengembangan Proyek CDM di Indonesia. Presentation at a discussion “Indonesia Telah Meratifikasi Protokol Kyoto – What Next?”, held by State Ministry for Forestry, Republic of Indonesia on August 5, 2004

Tver, D.F., Berry, R.W.: *The Petroleum Dictionary*. Van Nostrand Reinhold Company. New York. 1980

UNFCCC: Approved baseline methodology AM0009 - Recovery and utilization of gas from oil wells that would otherwise be flared. 2004a
http://cdm.unfccc.int/UserManagement/FileStorage/CDMWF_AM_577581847, viewed on October 26, 2004

UNFCCC: Approved baseline methodology AM0012 - Baseline methodology for biomethanation of municipal solid waste in India, using compliance with MSW rules. 2004
http://cdm.unfccc.int/UserManagement/FileStorage/CDMWF_AM_627397095, viewed on October 26, 2004

UNFCCC: Caring for climate - A guide to the Climate Change Convention and the Kyoto Protocol. Courir-Druck GmbH. Bonn. 2003
http://unfccc.int/resource/cfc_guide.pdf, viewed on July 8, 2004

UNFCCC: Consolidation of tools for demonstration of additionality (Annex 3 of EB15). In *Report of Fifteenth Meeting of the Executive Board*, September 1 – 3, 2004b
<http://cdm.unfccc.int/EB/Meetings/015/eb15repan3.pdf>, viewed on September 23, 2004

UNFCCC: Kyoto Protocol – Status of Ratification. October 5, 2004c
<http://unfccc.int/resource/kpstats.pdf>, viewed on October 6, 2004

UNFCCC: Kyoto Protocol to the United Nations Framework Convention on Climate Change. 1997.
<http://unfccc.int/resource/docs/convkp/kpeng.pdf>, viewed on July 8, 2004

UNFCCC: Methodologies for CDM project activities. 2004d
<http://cdm.unfccc.int/methodologies/PAmethodologies>, viewed on October 25, 2004

UNFCCC: Project Activity Cycle. 2004e
<http://cdm.unfccc.int/pac/index.html>, viewed on September 21, 2004

UNFCCC: Tool for the demonstration and assessment of additionality (Annex 1 of EB 16). In *Report of Sixteenth Meeting of the Executive Board*, October 21 – 22, 2004
<http://cdm.unfccc.int/EB/Meetings/016/eb16repan1.pdf>, viewed on October 27, 2004

Union of Concerned Scientist (UCS): The Impact of Global Warming in Asia. In *Global Warming – Early Warning Signs*. 2003
<http://www.climatehotmap.org/asia.html>, viewed on October 21, 2004

US Department of Energy (DOE): An Energy Overview of Argentina. 2004a
<http://www.fe.doe.gov/international/Western%20Hemisphere/argnover.html>, viewed on October 19, 2004

US Department of Energy (DOE): How Coal Gasification Power Plants Work . 2004b
<http://www.fe.doe.gov/programs/powersystems/gasification/howgasificationworks.html>, viewed on October 19, 2004

Wilder, M., Willis, M., Carmody, J.: Legal Issues Guidebook to the Clean Development Mechanism. Unep Risø Centre. Roskilde, 2004
<http://www.cd4cdm.org/Publications/CDM%20Legal%20Issues%20Guidebook.pdf>, viewed on June 28, 2004

World Bank: World Development Indicators. 2004a
<http://www.worldbank.org/data/wdi2004/>, viewed on September 30, 2004

World Bank's Global Gas Flaring Reduction (GGFR) Partnership: A Voluntary Standard for Global Gas Flaring and Venting Reduction. Washington DC. 2004b

World Bank's GGFR Partnership: Flared Gas Utilization Strategy – Opportunities for Small-Scale Uses of Gas. Washington DC. 2004c
<http://www.worldbank.org/ogmc/files/flaredgasutilizationstrategy.pdf>, viewed on July 19, 2004

World Bank's GGFR Partnership: Kyoto Mechanisms for Flaring Reductions. Washington DC. 2003
<http://www.worldbank.org/ogmc/files/KyotoMechanismsForFlaringReductions.pdf>, viewed on April 5, 2004

World Bank's GGFR Partnership: Gas Flaring Reduction Projects – Framework for Clean Development Mechanism (CDM) Baseline Methodologies. Washington DC. 2004d
<http://www.worldbank.org/ogmc/files/gfrframeworkforcdbaselinemethodologies.pdf>, viewed on September 29, 2004

World Bank's GGFR Partnership: Regulation of Associated Gas Flaring and Venting – A Global Overview and Lessons from International Experience. Washington DC. 2004e

World Bank's GGFR Partnership: Report on Consultations with Stakeholders. Washington DC. 2004f

World Commission on Environment and Development (WCED): Our Common Future. Oxford University Press. Oxford. 1987