

Posner, Richard A.

Working Paper

Remaking domestic intelligence

AEI Working Paper, No. 111

Provided in Cooperation with:

American Enterprise Institute (AEI), Washington, DC

Suggested Citation: Posner, Richard A. (2005) : Remaking domestic intelligence, AEI Working Paper, No. 111, American Enterprise Institute (AEI), Washington, DC

This Version is available at:

<https://hdl.handle.net/10419/280462>

Standard-Nutzungsbedingungen:

Die Dokumente auf EconStor dürfen zu eigenen wissenschaftlichen Zwecken und zum Privatgebrauch gespeichert und kopiert werden.

Sie dürfen die Dokumente nicht für öffentliche oder kommerzielle Zwecke vervielfältigen, öffentlich ausstellen, öffentlich zugänglich machen, vertreiben oder anderweitig nutzen.

Sofern die Verfasser die Dokumente unter Open-Content-Lizenzen (insbesondere CC-Lizenzen) zur Verfügung gestellt haben sollten, gelten abweichend von diesen Nutzungsbedingungen die in der dort genannten Lizenz gewährten Nutzungsrechte.

Terms of use:

Documents in EconStor may be saved and copied for your personal and scholarly purposes.

You are not to copy documents for public or commercial purposes, to exhibit the documents publicly, to make them publicly available on the internet, or to distribute or otherwise use the documents in public.

If the documents have been made available under an Open Content Licence (especially Creative Commons Licences), you may exercise further usage rights as specified in the indicated licence.



American Enterprise Institute for Public Policy Research

Remaking Domestic Intelligence

Richard A. Posner

AEI WORKING PAPER #111, JUNE 20, 2005

www.aei.org/workingpapers
<http://www.aei.org/publication22726/>

Revised June 20, 2005

REMAKING DOMESTIC INTELLIGENCE

Richard A. Posner¹

Abstract

The magnitude of the terrorist threat to the United States, coupled with the lack of coordination among our domestic intelligence agencies and the failure of the lead agency, the FBI, to develop an adequate domestic intelligence capability, argues compellingly for reform. Because the FBI's failure is systemic, being rooted in the incompatibility of criminal law enforcement (the FBI's principal mission) with national-security intelligence, the reform must have a structural dimension. The WMD (Robb-Silberman) Commission's proposal, which the President is reported to have endorsed, is to create a domestic intelligence agency within the FBI by fusion of its three units that at present share intelligence responsibility. Such a fusion may or not be a good idea; but clearly it is not enough. The Director of National Intelligence should take the coordination and command of domestic intelligence firmly into his hands by appointing a deputy for domestic intelligence, while the President should by executive order create outside of (but not in derogation of) the FBI a domestic intelligence agency, modeled on such foreign agencies as the Canadian Security Intelligence Service, that would have no law enforcement functions. The agency could be lodged in the Department of Homeland Security.

I. THE PROBLEM

Introduction. My subject is "domestic national-security intelligence" ("domestic intelligence" for short), by which I mean

¹ Judge, U.S. Court of Appeals for the Seventh Circuit; Senior Lecturer, University of Chicago Law School. This paper, a previous draft of which is posted online at <http://www-hoover.stanford.edu/pubaffairs/we/2005/posner06.html>, draws on chapter 6 of my book *Preventing Surprise Attacks: Intelligence Reform in the Wake of 9/11* (2005), and on my unpublished paper "The Actual and the Optimal Structure of the U.S. Intelligence System" (May 2005). I thank Lindsey Briggs, Paul Clark, and Meghan Maloney for exemplary research assistance, and Stewart Baker, Scott Hemphill, Grace Mastalli, Ted Price, Laurence Silberman, George Spix, and James Q. Wilson for valuable advice and comments; Spix's extensive and invariably helpful comments on successive drafts deserve a special acknowledgment. I emphasize that the views presented here, and any errors that remain, are my own.

intelligence concerning the threat of major, politically motivated violence, or equally grievous harm to security or the economy, inflicted within the nation's territorial limits by international terrorists, homegrown terrorists, or spies or saboteurs employed or financed by foreign nations. The 9/11 attacks were thus within the scope of domestic intelligence. They were mounted from within the United States by terrorists who had been here for months—indeed, in some cases, intermittently for years. The danger of terrorist acts committed on the soil of the United States has not abated. Despite strenuous efforts to improve homeland security, we may be in as great danger as we were on September 10, 2001, or even greater. Not only is the hostility of significant segments of the vast Muslim world (including large and restive Muslim minorities in European nations, such as the United Kingdom, France, and the Netherlands) toward the United States unabated; weapons of mass destruction—atomic bombs, dirty bombs (conventional explosives that scatter radioactive material), chemical agents, lethal pathogens, and deadly-when-abused industrial materials—are shrinking in cost and growing in availability. Their cost will continue to fall and their availability to rise faster than the defensive measures contemplated at present. Nor can it be assumed that the threat of terrorism with weapons of mass destruction comes only from the Muslim world, or indeed only from foreign groups or nations. The Unabomber, Timothy McVeigh, violent Puerto Rican separatists, the Weathermen, and the Black Panthers are historical examples of purely domestic U.S. terrorists whose successors may wield enormously increased lethal power.²

It is difficult to imagine any major attack on the United States (other than by an enemy nation) that would not have a domestic aspect. Even an attack that consisted of exploding a ship full of ammonium nitrate (or carrying a dirty bomb or a nuclear bomb) in a U.S. port would occur within the defensive perimeter of the Coast Guard, whose intelligence service is a

² On the threat to U.S. national security posed by weapons of mass destruction in the hands of terrorists, see Richard A. Posner, *Catastrophe: Risk and Response* 71–86 (2004), and references cited there.

part of the domestic intelligence system, and would undoubtedly have been prepared with the assistance of individuals residing in the United States because the attackers would need information about port security.

The very concept of “domestic intelligence” might be questioned, on the ground that borders have no significance when the major threat to national security comes from international terrorism. Certainly domestic and foreign intelligence must be closely coordinated. But there are enough differences to preserve the distinction. Domestic intelligence presents civil liberties concerns that are absent when intelligence agencies operate abroad; purely homegrown terrorists (that is, terrorists who may have no family, personal, ethnic, or political ties to a foreign country) are a major potential threat in an era of weapons of mass destruction; recruitment, training, deployment, and security requirements are different for intelligence officers operating inside and outside our national borders; surveillance methods are apt to differ; and domestic intelligence must work closely with the nation’s public and private police and protection forces to create a public-private, federal-state-local, nationwide network of eyes and ears. I return to the question of the distinctive character of a domestic intelligence agency, and its relation to other components of the overall national-security system, in Part III.

The importance of domestic intelligence is clear. Yet it is the weakest link in the U.S. intelligence system. One of the underlying reasons is that Americans tend to disregard foreign experience. The report of the 9/11 Commission, for example, cast only a cursory glance at foreign intelligence systems, even though some of them, notably the British, French, Israeli, and German, are well regarded. These are also nations that have a longer experience of dealing with terrorism than the United States. Each has a domestic intelligence agency that is separate from its national police force, its counterpart to the FBI. By a domestic intelligence agency I mean an agency that conducts domestic intelligence, but does not have the power of arrest or other law enforcement powers, and that confines its operations to the national territory. Thus, while a domestic intel-

ligence agency will want to analyze relevant information wherever the origin of the information may be, its own intelligence collection activities will be confined to its national territory; it will rely on other agencies to gather relevant information abroad, though like most generalizations this one has exceptions: often a domestic intelligence agency will station a few of its personnel abroad.

In Britain the domestic intelligence agency is the Security Service, better known as MI5; in France, the Direction de la Surveillance du Territoire (DST); in Germany the Bundesamt für Verfassungsschutz (BfV); in Israel, Shin Bet. Examples of similar agencies in other nations are the Public Security Investigation Agency in Japan, the Australian Security Intelligence Organization, and—an agency I shall especially emphasize as a possible model for a U.S. domestic intelligence agency—the Canadian Security Intelligence Service.³ There is an international consensus that a nation's intelligence system should include a domestic intelligence agency that is separate from the police. The consensus includes the nations of “old Europe” so admired by the American liberals who are in the forefront of opposition to emulating the European approach to domestic security.

The United States, alone among major nations (so far as I know) does not have such an agency; and the 9/11 Commission gave the back of its hand⁴ to proposals⁵ that the United States

³ On the various foreign domestic intelligence agencies, see, for example, Michael A. Turner, *Why Secret Intelligence Fails*, ch. 4 (2005); Peter Chalk and William Rosenau, *Confronting the 'Enemy Within': Security Intelligence, the Police, and Counterterrorism in Four Democracies* (RAND Corp. 2004); Todd Masse, “Domestic Intelligence in the United Kingdom: Applicability of the MI-5 Model to the United States: Report for Congress” (Congressional Research Service, Order Code RL31920, May 19, 2003). Some of the agencies, though not the British or Canadian, have some ancillary law-enforcement responsibilities.

⁴ *Final Report of the National Commission on Terrorist Attacks Upon the United States* 423–424 (2004).

⁵ See, for example, William E. Odom, *Fixing Intelligence: For a More Secure America*, ch. 8 (2003); John Deutch, “Strengthening U.S. Intelligence,” testimony before the 9/11 Commission, Oct. 14, 2003, at www.9-11commission.gov/hearings/hearing4/witness_deutch.htm; Paul R. Pillar,

create one. Members and staff of the commission did, it is true, visit the director-general of MI5, who told them she “doubt[ed] that such an agency could operate under the restrictions of the U.S. Constitution and the traditionally higher American emphasis on civil liberties and the right to privacy. ‘Even the Brits think it wouldn’t work here,’ 9/11 Chairman Thomas Kean said in a news conference shortly after the commission issued its report.”⁶ To defer to the opinion of a foreign official concerning the limits that U.S. law and custom would place on a U.S. domestic intelligence service makes little sense; and all she may have meant was that a U.S. service couldn’t be a carbon copy of MI5 because the legal framework of a U.S. service would be different. It does not follow that the difference (which is anyway slight now that the U.K. has signed the European Convention on Human Rights) would render a U.S. domestic intelligence agency ineffectual.

The 9/11 Commission’s rejection of proposals to create such an agency was tentative. It said the agency wasn’t needed *if* the commission’s other recommendations were adopted.⁷ Many of them were whittled down by the Intelligence Reform Act and Terrorism Prevention Act of 2004, the legislative response to the 9/11 Commission’s report. So we don’t know what the commission would think of the idea today—or at least didn’t until the commission decided to reconstitute itself (albeit as a private, no longer a governmental, commission).⁸ The commissioners have been so taken aback by the FBI’s inability to rectify the errors identified in the commission’s report of July 2004 that they are now wondering whether the creation of a separate domestic intelligence agency might not be the right

“Intelligence,” in *Attacking Terrorism: Elements of a Grand Strategy* 115, 133–134 (Audrey Kurth Cronin and James M. Ludes eds. 2004); William Rosenau and Peter Chalk, “Can We Learn from Others?” *Wall Street Journal*, Apr. 15, 2004, p. A14. See also the statement by Senator Richard Shelby, note 16 below, from which I shall be quoting extensively.

⁶ Scott J. Paltrow, “Secrets and Spies: U.K. Agency Makes Gains in Terror War; Can It Work Here?” *Wall Street Journal*, Oct. 6, 2004, p. A1.

⁷ *Final Report*, note 4 above, at 423.

⁸ Philip Shenon, “Sept. 11 Panelists Press for Data on Terror Risk,” *New York Times* (national ed.), June 6, 2005, p. A1.

course of action after all.⁹ Amidst mounting criticisms of the FBI's continuing inability to perform the domestic intelligence role competently, the President is reported to have adopted a halfway house to creating a domestic intelligence agency: namely to create a domestic intelligence entity within the FBI by fusing the Bureau's three divisions that have intelligence responsibilities into a single unit under the direction of an associate director of the FBI.¹⁰ Because two of these divisions, as we'll see, have law-enforcement as well as intelligence duties, and because the intelligence activities of the new unit may not be limited to national-security intelligence, the unit will not be a true domestic intelligence agency, quite apart from its being lodged in a police department.

The United States *may* be right to have rejected the idea of creating such an agency, and these other countries wrong (or right for them but not for us). We are larger and more diverse, have a more robust civil liberties tradition, and face a wider range of threats. But the fact that we are out of step should give us pause. The criticisms of the foreign approach that are based on the supposedly unique characteristics of the United States are superficial. One is that "if the Homeland Security Department and 170,000 people to be integrated is going to take a couple of years, standing up a brand new domestic intelligence agency would take a decade."¹¹ Another is that "We're

⁹ "The FBI has stumbled badly in its attempts to remake itself since the Sept. 11, 2001, attacks and is plagued by high turnover, poor training and its continued inability to build a modern computer system, according to a panel convened yesterday by the members of the commission that investigated the terror strikes. The problems are so acute that members of the influential commission may want to reconsider whether the United States needs a separate agency to handle domestic intelligence, one Democratic member said." Dan Eggen, "FBI Fails to Transform Itself, Panel Says: Former Sept. 11 Commission 'Taken Aback' by Personnel, Technology Problems," *Washington Post*, June 7, 2005, p. A4.

¹⁰ David Johnston, "Antiterror Head Will Help Choose an F.B.I. Official: A Focus on Intelligence: Under Pressure, Bureau Will Cede a Piece of Its Prized Autonomy," *New York Times*, June 12, 2005 (final national ed.), § 1, p. 1.

¹¹ Excerpts of Testimony from Louis J. Freeh and Janet Reno in *The 9/11 Investigations: Staff Reports of the 9/11 Commission, Excerpts from the*

not England. We're not 500 miles across our territory. We have thousands of miles to cover. Would you propose to create an organization that had people all over the United States, as the FBI does?"¹² The first criticism overlooks the fact that creating a domestic intelligence agency cannot be compared to the creation of the Department of Homeland Security, a mega-agency that dwarfs the entire domestic intelligence community. The FBI in 2002 was said to have only 1,644 employees on its anti-terrorism staff.¹³ This estimate is too small, as we'll see; but we'll also see that the total number of federal employees exclusively engaged in domestic intelligence probably does not exceed 6,000 to 7,000, which is less than 4 percent of the number of employees of DHS. Furthermore, it's more difficult to consolidate a number of heterogeneous agencies into a single department than to create a new agency that, as I envisage it (see Part III of this paper), might have as a few as a thousand employees.

As for the second criticism, although we are indeed not England, a domestic intelligence agency would not require much if any field staff because my proposal does not envisage removing staff from the FBI. The Bureau would continue to play a large role in domestic intelligence.

The critics are correct that other nations tend to be more centralized than we; the United Kingdom, for example, has only about 50 police forces while the United States has more than 20,000. Domestic intelligence has to liaise with local law enforcement, whose personnel may turn up clues to the existence of terrorist or proto-terrorist gangs and to the identity of members, sympathizers, and foreign contacts. Also, terrorists

House-Senate Joint Inquiry Report on 9/11, Testimony from Fourteen Key Witnesses, including Richard Clarke, George Tenet, and Condoleezza Rice 257, 264 (Steven Strasser ed. 2004). The correct number of employees for the Department of Homeland Security is 180,000.

¹² Remarks of William Webster quoted in Sen. Select Comm. on Intelligence and House Permanent Select Comm. on Intelligence, *Joint Inquiry into Intelligence Community Activities before and after the Terrorist Attacks of September 11, 2001* 351 (Dec. 2002).

¹³ John Diamond, "CIA & FBI in the Hot Seat," *USA Today*, June 4, 2002, p. 10A.

sometimes commit quite ordinary crimes in order to finance their terrorist activities—bank robberies are a traditional example—though this has not been characteristic of recent terrorist activity in this country.

It is easier for thousands of local police departments, many quite small, to communicate with a single federal agency than it would be for them to communicate with two agencies. But all this means is that in the division of responsibilities among the various components of an overall domestic intelligence system that included a domestic intelligence agency, liaison with local police forces would remain largely an FBI responsibility.¹⁴ Even before 9/11, the FBI had established “Joint Terrorism Task Forces” with local law enforcement authorities; these task forces now exist in scores of cities.

The FBI’s Failures. By the 9/11 Commission’s own account, the FBI turned in the most lackluster performance of any agency in the run up to 9/11,¹⁵ even though the Bureau had (and has) the primary responsibility among police and intelligence services for preventing terrorist attacks on the nation from within, as well as for preventing espionage and sabotage by foreign nations (the counterintelligence function, which is

¹⁴ Largely, but not entirely. The FBI isn’t loved by local law enforcers, and a new intelligence agency would be free from the traditions and rivalries that inhibit day-to-day cooperation now. A “hat in hand” (with money) and “I’m not competing with you, I need you”) attitude of the new agency would make local law enforcement more likely to cooperate in providing information and in making available suspects to be “turned” rather than arrested and prosecuted. More on this in Part III.

¹⁵ For other criticism of the FBI’s pre-9/11 performance as an antiterrorist agency, see U.S. Dept. of Justice, Office of the Inspector General, *A Review of the FBI’s Handling of Intelligence Information Relative to the September 11 Attacks* (Nov. 2004), <http://www.justice.gov/oig/special/0506/final.pdf>, summarized in Eric Lichtblau, “Report Details F.B.I.’s Failure on 2 Hijackers: Follow-Up Is Faulted on 9/11 Intelligence,” *New York Times*, June 10, 2005, p. A1; Anonymous (Michael Scheuer), *Imperial Hubris: Why the West Is Losing the War on Terror* 185–191 (2004); *Joint Inquiry*, note 12 above, at 6, 243–246, 357–359 (Dec. 2002); Staff Statement No. 9, “Law Enforcement, Counterterrorism and Intelligence Collection in the United States prior to 9/11,” in *The 9/11 Investigations*, note 11 above, at 239–256; Odom, note 5 above, ch. 8; and the Shelby statement, cited in the next footnote.

analytically similar to counterterrorism). The 9/11 attackers were foreigners, but the attacks were mounted from inside the United States by individuals who had been living here for months—some of them, off and on for years. A request by one of the FBI field offices to apply for a warrant to search the laptop of Zacarias Moussaoui (a prospective hijack pilot) was turned down. A prescient report on flight training by Muslims in Arizona was ignored by FBI headquarters. There were only two analysts on the Bin Laden beat in the entire Bureau. Director Louis Freeh's directive that the Bureau focus its efforts on counterterrorism was ignored.

An especially pointed and insightful critique appears in the separate statement of Senator Shelby, the vice chairman of the Senate Select Committee on Intelligence, appended to the December 2002 report of the joint congressional inquiry into the 9/11 intelligence failure. With reference to the Moussaoui episode, Shelby notes that "FBI Headquarters actually *prohibited* intelligence investigators in Minneapolis from notifying the Criminal Division at the Justice Department about the Moussaoui situation, and *prohibited* agents from pursuing a criminal search warrant against him."¹⁶ "The Bureau did not know what information it possessed, it did not approach this information with an intelligence analysis mindset, and it too often neglected to inform other agencies of what it *did* know or believe."¹⁷ Shelby concludes that

though still renowned for its criminal investigative competence, the FBI has shown a disturbing pattern of collapse and dysfunction in its counterintelligence and counterterrorism functions. These recurring problems have, in turn, led many observers—and Members of Congress—increasingly to lose faith in the Bureau's ability to meet the national security challenges it faces, despite a series

¹⁶ "September 11 and the Imperative of Reform in the U.S. Intelligence Community: Additional Views of Richard C. Shelby, Vice Chairman, Senate Select Committee on Intelligence," Dec. 20, 2002, pp. 52–53, http://www.fas.org/irp/congress/2002_rpt/shelby.html (all emphases in my quotations from Shelby's statement are his).

¹⁷ *Id.* at 67.

of internal reorganizations over the past several years that have failed to rectify the situation.

In light of the FBI's dismal recent history of disorganization and institutional incompetence in its national security work, many of us in Congress have begun to consider whether it might better serve the interests of the American people to separate the counterintelligence and counterterrorism function of the Bureau into an entirely separate organization—one that would be free of the structural, organizational, and cultural constraints that have greatly handicapped the FBI's ability to conduct the domestic intelligence work our country depends upon it to perform.¹⁸

The reasons Shelby gives for the FBI's dysfunction as an intelligence agency are illuminating (I reprise and elaborate them later in this paper):

Fundamentally, the FBI is a law enforcement organization: its agents are trained and acculturated, rewarded and promoted within an institutional culture the primary purpose of which is the prosecution of criminals. Within the Bureau, information is stored, retrieved, and simply *understood* principally through the conceptual prism of a "case"—a discrete bundle of information the fundamental purpose of which is to prove elements of crimes against specific potential defendants in a court of law.

The FBI's reification of "the case" pervades the entire organization, and is reflected at every level and in every area: in the autonomous, decentralized authority and traditions of the Field Offices; in the priorities and preference given in individual career paths, in resource allocation, and within the Bureau's status hierarchy to criminal investigative work and *post hoc* investigations as opposed to long-term analysis; in the lack of understanding of and concern with modern information management technologies and processes; and in deeply-entrenched individual mindsets that prize the production of evidence-supported narratives of defendant wrongdoing over the drawing of probabilistic inferences based upon incomplete and fragmentary information in order to support decision-making...Far from embracing probabilistic inference, "knowledge" in a law enforcement context aspires—in its

¹⁸ Id. at 61–62.

ideal form at least—not only to *certainty* but also to *admissibility*, the two essential conceptual elements of being able to prove someone guilty beyond a reasonable doubt in a court of law. Within such a paradigm, information exists to be *segregated* and ultimately employed under carefully-managed circumstances for the single specific purpose for which it was gathered.¹⁹

After 9/11, the Bureau, under a new director, Robert Mueller, vowed to do better. His efforts²⁰ have fallen far short of success.²¹ In part because the Bureau has been plagued by excessive turnover in the executive ranks of its intelligence and antiterrorism sections,²² and even more so in its information-technology teams, it took the Bureau two years after 9/11 just to devise a *plan* to reform its counterterrorism program.²³ We know now that the plan was a failure; for otherwise the President would not be forcing the WMD Commission's recommendation for reorganization (the fusion approach that I described earlier) on a recalcitrant Bureau.

Three and a half years after acknowledging in the wake of 9/11 the inadequacy of its information technology for intelligence purposes and vowing to develop an adequate system, the Bureau abandoned a \$170 million program called "Virtual Case File" intended to enable FBI agents to input intelligence data

¹⁹ Id. at 62–63.

²⁰ Summarized in U.S. Department of Justice, *Federal Bureau of Investigation, The FBI's Counterterrorism Program since September 2001: Report to the National Commission on Terrorist Attacks upon the United States* (Apr. 14, 2004).

²¹ Staff Statement No. 12, "Reforming Law Enforcement, Counterterrorism, and Intelligence Collection in the United States" (National Commission on Terrorist Attacks Upon the United States, Staff Report, Apr. 14, 2004); Testimony of Dick Thornburgh, Chairman, Academy Panel on FBI Reorganization (National Academy of Public Administration, June 18, 2003).

²² Dan Eggen, "FBI Names 6th Antiterrorism Chief since 9/11," *Washington Post*, Dec. 29, 2004, p. A17. "All of the FBI's senior positions have turned over at least once since the Sept. 11 attacks, and many have changed hands numerous times." Id.

²³ Laurie E. Ekstrand, "FBI Transformation: FBI Continues to Make Progress in Its Efforts to Transform and Address Priorities" 6 (U.S. General Accounting Office GAO–94–578T, Mar. 23, 2004).

into their computers without having to undergo “a cumbersome, time-consuming process of preparing a paper record of that information, seeking the necessary approvals, then uploading the document into an existing database.”²⁴ Because the FBI chose to develop Virtual Case File noncollaboratively, the federal and many of the state agencies with which it works were delaying upgrades of their own systems in the hope that by waiting until VCF was up and running they could configure their own systems to be compatible with the FBI’s.

Even more troubling, the Bureau plans to take another three and a half to four years to complete the acquisition, at even greater (probably much greater) expense than that of the failed Virtual Case File system, of information technology deemed adequate to the Bureau’s needs.²⁵ What Senator Shelby said about the Bureau’s unhappy experience with information technology in December 2002 remains true today: “In addition to these cultural and organizational problems—or perhaps in large part because of them—the FBI has never taken information technology (IT) very seriously, and has found itself left with an entirely obsolete IT infrastructure that is wholly inadequate to the FBI’s current operational needs,

²⁴ Statement of Robert S. Mueller, III, Director, Federal Bureau of Investigation, before the U.S. Sen. Comm. on Appropriations, Subcomm. on Commerce, Justice, State and the Judiciary 3, Feb. 3, 2005, <http://www.fbi.gov/congress05/mueller020305.htm>. The Virtual Case File fiasco is vividly described in Dan Eggen, “FBI Pushed Ahead with Troubled Software,” *Washington Post*, June 6, 2005 p. A1.

²⁵ Griff Witte, “FBI Outlines Plans for Computer System: Program Will Replace Canceled Project,” *Washington Post*, June 9, 2005, p. A19; Eric Lichtblau, “F.B.I. Ends a Faltering Effort to Overhaul Computer Software,” *New York Times* (late ed.), Mar. 9, 2005, p. A16; Larry Greenemeier, “Tech vs. Terrorism: The FBI Stumbled Badly in Modernizing Its IT to Help Fight Terrorism. Here’s How the Bureau Plans to Get on Track,” *Information-Week*, June 6, 2005, <http://www.informationweek.com/story/showArticle.jhtml?articleID=164300083>. The fullest and most authoritative account of the FBI’s information-technology troubles that I have read is Allan Holmes, “Change Management: Why the G-Men Aren’t I.T. Men,” *CIO*, June 15, 2005, <http://www.cio.com/archive/061505/gmen/html>.

much less to the task of supporting sophisticated all-source intelligence fusion and analysis.”²⁶

One reason for the delays in and inordinate expense of the FBI’s program for upgrading its information technology is that, consistent with the Bureau’s emphasis on criminal investigation, the program is not limited to intelligence. It encompasses the entirety of the FBI’s operations, and the resulting scope and ambition of the program endanger its success because (to beat a tired drum) criminal investigation and national-security intelligence have different methods and priorities, and the compromises necessary to satisfy both sets of user are difficult to devise and implement. Granted, investigations of ordinary crimes can yield information of value to national-security intelligence collectors, so there is value in having a single database for everything in the FBI’s files, but that value has to be traded off against the cost, delay, and possible failure of so ambitious a venture.

Not that the ambitious venture should fail; it shouldn’t, because it is not *really* that ambitious, given the vast storage capacity and search capability of today’s commercial off-the-shelf computer software. Google enables near-instantaneous searching of eight billion Web pages; Amazon.com enables near-instantaneous matching of millions of individuals with millions of products. The adaptation of these mature technologies to the needs of the FBI for data storage, retrieval, sorting, and matching should be straightforward. Ten thousand FBI special agents doing four reports a day of 250 words each, 250 days a year, for 10 years would produce a total of 100 million pages, which is only one-eightieth the searchable, indexed contents of Google.

The Failures Are Rooted in Structure. I am generally skeptical of organizational solutions to intelligence problems, most of which are not organizational problems.²⁷ But the FBI’s inadequate performance of the domestic intelligence function is an organizational problem. Placing the domestic intelligence

²⁶ “September 11 and the Imperative of Reform,” note 16 above, at 72.

²⁷ That skepticism is a major theme of my book *Preventing Surprise Attacks*, note 1 above.

function in a criminal investigation agency ensures, as other nations realize, a poor fit. “Mixing law enforcement with counterintelligence’ simply cannot work...‘Cops’ cannot do the work of ‘spies.’”²⁸

Criminal investigation is retrospective. A crime has been committed and the investigators go about trying to find the criminal and when they do they arrest him and continue gathering evidence that will be admissible in court to prove his guilt. If the criminal activity that is being investigated is of an ongoing nature, as in the case of gang activity, the investigators may decide to allow it to continue until the activity generates irrefutable evidence of guilt. But then it will pounce. And at every stage the investigator will take extreme care not to commit a procedural violation that might jeopardize a conviction. Also, he will balk at sharing with others any of the information that he obtains in his investigation, lest a leak tip off a suspect or make it easier for him to defend himself in court should a prosecution be instituted. All that the sharing of information about a case can do from the FBI agent’s perspective (as well as that of the local U.S. Attorney, whose support the agent requires) is to weaken his ability to control the future of the case.

Criminal investigation is case-oriented, backward-looking, information-hugging, and fastidious (for fear of wrecking a prosecution). Intelligence, in contrast, is forward-looking, threat- rather than case-oriented, free-wheeling. Its focus is on identifying and maintaining surveillance of suspicious characters and on patiently assembling masses of seeming unrelated data into patterns that are suggestive of an emergent threat but may be based on speculative hypotheses far removed from probable cause, let alone from proof beyond a reasonable doubt. When intelligence is working well, the spy or traitor or terrorist is caught early, before he does much damage, and often he can be turned to our advantage. The orientation of intelligence toward preventing crimes from occurring or even from being contemplated, rather than toward prosecution after they occur,

²⁸ “September 11 and the Imperative of Reform,” note 16 above, at 74.

would prevent a domestic intelligence agency from obsessing over procedural missteps that might jeopardize a conviction.

The FBI argues that because terrorism, espionage, and sabotage, the principal concerns of a domestic intelligence agency, are criminal, and because intelligence is an element of criminal law enforcement—notably in the case of “victimless crimes,” where (by definition) the law-enforcement authorities cannot sit back and wait for the victim of the crime to complain but must penetrate the criminal gang much as in an intelligence operation directed against a terrorist group—terrorism intelligence can be assimilated to the FBI’s criminal law enforcement responsibilities. Not so.

The defining characteristics of the activities with which intelligence is concerned are sharply different from those of ordinary federal crimes. Terrorist activities are politically motivated (in a broad sense of “political” that extends to destructive activities motivated by religious, class, racial, or ethnic hatred) and are potentially much more dangerous than nonpolitical crimes because they aim to injure or destroy the nation as a whole, or entire population groups, or major institutions, or otherwise wreak havoc on a large scale. To counter terrorist activity requires types of knowledge—of political movements, foreign countries and languages, the operational methods of terrorists, spies, and saboteurs, and the characteristics and availability of weapons of mass destruction—that criminal investigators do not possess. It requires in fact a different mindset. Good police officers learn to think like criminals; good intelligence officers learn to think like terrorists and spies. The hunter must be empathetic with (as distinct from sympathetic to) his quarry. Cops and spies have different quarry.

Also required, as attention moves from criminal investigation to national-security intelligence, is a shift in focus from apprehension to prevention. For punishment after the fact cannot undo the consequences of a catastrophic attack.²⁹ Nor is the

²⁹ Philip B. Heymann, *Terrorism and America: A Commonsense Strategy for a Democratic Society* 129–130 (1998), points out that criminal law enforcers are likely to “have little interest in all but the first two of the following eight questions that are critical to prevention” of terrorism: “[1] Who are the

threat of punishment likely to deter the attack in the first place. Criminal law aims to deter crime by punishing some significant fraction of offenders, as well as to incapacitate those offenders (the undeterred) from committing further crimes for a length of time (the period of their imprisonment). Because the most dangerous modern terrorists are largely undeterrable, notably suicide bombers, who because their first successful attack is their last cannot be locked away after that attack to prevent them from repeating, law enforcement alone cannot defeat terrorism.³⁰

It can even impede the struggle against terrorism: in some cases by prematurely revealing what the government knows, enabling the terrorists to adapt to and thwart the government's campaign against them through a change in their methods of operation, their footprint; in other cases by failing to intervene early enough (that is, before criminal activity has occurred). Melissa Mahle points out that

the preparation stage [of terrorist attacks is]...the most vulnerable to detection and disruption, and the execution [stage]...the most difficult to disrupt...The preparation stage, which includes recruiting, training, casing, and putting support assets in place, requires more people and more movement than the execution phase...All of these activities [undertaken in preparation for the 9/11 attacks] required the movement of people and money and communication between cells, creating a hum of activity that in-

members actively engaged in planning to use violence for political purposes? [2] What is their motivation? [3] Where are they located? [4] Who in the population is likely to join the group or provide forms of support needed for its continued operations? [5] What is the extent and nature of the support the group is receiving from others outside the country, including another state? [6] How does the group handle the problems of remaining clandestine and yet carrying out political violence? What is its *modus operandi*? [7] What type of attacks is the group capable of? [8] What is the strategy behind their planning?"

³⁰ The qualification in "largely" is important, however. Even suicide bombers are deterrable in the following sense: if they know they're highly likely to be intercepted before they can detonate their bombs, they may decide to switch to another activity, because the expected benefit of their suicidal attack will have been reduced.

telligence assets are trained to pick up. The FBI caught some pieces, but made no attempt to assemble them into a larger picture.³¹

Activities in the preparation stage are often too ambiguous to be readily provable as crimes; some are only minor crimes; some are not crimes at all. Preparatory activities are therefore not a very attractive target for law enforcers. Identifying, assessing, and tracking such activities are quintessential intelligence tasks, rather than tasks congenial to law enforcers. Although prosecuting preparers, difficult as it is, may nevertheless have value in deterring entry into that stage, often the more effective strategy is not to arrest and prosecute the preparers but rather to monitor them carefully in order to ascertain the scope, intentions, membership, and affiliations of the terrorist group.

A law-enforcement approach to terrorism can cause intelligence data to be evaluated from the too-narrow perspective of its utility in building a criminal case; retard the sharing of information lest full credit for a successful prosecution be denied the field office that began the investigation; and discourage the collection and retention of information. This last point is related to the difference between collecting information for the sake of knowledge and collecting it for the sake of building a case. Criminal investigators want to collect enough information to prove their case but not enough to give defense counsel information that may be usable to exculpate the defendant. Intelligence officers don't have that inhibition.

A recent incident involving the arrests in New York of two Muslim teenage girls whom the FBI suspected of wanting to become suicide bombers, and held in custody for six weeks, illustrates how emphasis on a criminal-law response to terrorism can impair vital "hearts and minds" strategies. The arrests caused indignation in the New York Muslim community—whose loyalty and goodwill (as the FBI recognizes) are impor-

³¹ Melissa Boyle Mahle, *Denial and Deception: An Insider's View of the CIA from Iran-Contra to 9/11* 327–328 (2004).

tant safeguards against domestic terrorism.³² It is natural for a law enforcement agency to want to arrest a person suspected of criminal activity. An intelligence agency, rather than wanting the girls arrested, would want to discover who had put the idea of becoming suicide bombers in their mind (maybe no one); and its low-key investigation might culminate in simply a chat with the girls' parents.

The performance of criminal investigators, unlike that of intelligence officers, can be evaluated by objective, indeed quantitative, criteria, such as number of arrests weighted by successful convictions, with successful convictions weighted in turn by length of sentence imposed, amount of property recovered, and amount of favorable publicity generated.³³ Intelligence officers cannot be evaluated by such objective criteria; their successes are often invisible, indeed unknowable. For example, the earlier a plot is detected and disrupted, the more difficult it is to know whether it ever had a chance of success. And information obtained by intelligence officers may be only a small part of the total information that enabled a threat to be detected and thwarted.

This asymmetry of performance measurement creates a serious problem in the hiring and retention of able intelligence officers. Able employees prefer objective to subjective performance criteria; they know they'll do better if judged by such criteria than if their performance is evaluated by nonobjective, nonquantifiable, criteria that may include personality, appearance, personal connections, and sheer luck.³⁴ Thus in an agency such as the FBI that combines criminal investigation with intelligence, the abler recruits will gravitate toward criminal investigation. They may be forced to undergo some intelligence

³² Andrea Elliott, "You Can't Talk to an F.B.I. Agent That Way, or Can You?" *New York Times* (national ed.), June 4, 2005, p. A13.

³³ "The [FBI] rewarded agents based on statistics reflecting arrests, indictments, and prosecutions. As a result, fields such as counterterrorism and counterintelligence, where investigations generally result in fewer prosecutions, were viewed as backwaters." Staff Statement No. 9, note 15 above, at 239, 241.

³⁴ Luis Garicano and Richard A. Posner, "Intelligence Reform since 9/11: An Organizational Economics Approach" (unpublished, April 2005).

training and to do stints in intelligence jobs, but always they will be looking to return to the main career track.

Henry Kissinger has remarked that “intelligence personnel in the real world are subject to unusual psychological pressures. Separated from their compatriots by security walls, operating in a culture suspicious of even unavoidable secrecy, they are surrounded by an atmosphere of cultural ambiguity. Their unadvertised and unadvertisable successes are taken for granted, while they are blamed for policies that frequently result from strategic rather than intelligence misjudgments.”³⁵ This does not sound like the description of an FBI agent, and it casts doubt on the adequacy of the FBI’s post-9/11 program of providing intelligence training to its criminal investigators. “The worlds of law enforcement and intelligence are far apart. They have different roles, different rules, and different cultures, and often they do not speak the same language.”³⁶ The two “worlds” don’t fit comfortably together in the same agency.

The difference between the two worlds is, in major part, the difference between disruption and punishment. A terrorist plot can be disrupted without going to court. (“Hi, we’re the 6 o’clock news team, and we hear you’re up to no good.”) An agency that is not responsible for bringing criminals to justice can concentrate full time on pursuing terrorists without any of the distractions created by the complex demands of criminal justice (including concerns with discovery and proof). Success from the standpoint of intelligence can be chasing terrorists out of the country and making sure they don’t return, or even leaving them in place but turning them into government informants. One thing that’s hampered the FBI in creating a “Virtual Case File” adequate to its intelligence mission is the Bu-

³⁵ Henry Kissinger, “Better Intelligence Reform: Lessons from Four Major Failures,” in Senate Appropriations Comm., *Review of the 9/11 Commission’s Intelligence Recommendations: Hearings before the Committee on Appropriations, United States Senate*, 108th Cong., 2d Sess., pp. 7, 9 (Sen. Hearing 108–614, Sept. 21–22, 2004).

³⁶ Elizabeth Rindskopf, “Comment,” in *U.S. Intelligence at the Crossroads: Agendas for Reform* 256 (Roy Godson, Ernest R. May, and Gary Schmitt eds. 1995).

reau's traditional reluctance to keep full records (that is, including interview notes and other working papers) of its investigations, lest defendants use them in discovery; the Department of Justice has an "open files" policy intended to induce guilty pleas by allowing a criminal defendant's lawyer to read the Department's file on the case.

Most of the FBI's employees, including 90 percent of its agents, as distinct from support staff, are stationed in the Bureau's 56 field offices rather than in its Washington headquarters.³⁷ This geographic dispersal is another reflection of the Bureau's emphasis on criminal investigation and another impediment to domestic intelligence. Most federal crime is local and is prosecuted locally by one of the 96 U.S. Attorneys' offices, which like the FBI's field offices are scattered across the nation. The FBI agents in these offices essentially work for the U.S. Attorney, whose only mission is prosecuting criminal (and to a lesser extent civil) cases, so it is likely to be the agent's only, or at least overriding, concern as well. The reluctance of the field offices to share information with each other reflects both the local focus of the special agents and the objective criteria of advancement that I mentioned. No local office wants its cases "stolen," and its "numbers" thereby reduced, by another office to which it might have conveyed the results of its investigation of some crime. Hence the "office of origin" mentality that treats the field office that originates a case as its owner. But whereas most federal crime is local, the principal dangers to domestic security at present emanate from international terrorist groups. Clues to their activities may be scattered all over the world, so that effective intelligence requires combining scraps of information regardless of geographic origin rather than allowing information to be sequestered in local offices.

The marriage of criminal investigation and domestic intelligence in the FBI complicates the coordination of domestic and foreign intelligence. Often the same suspects are tracked outside the U.S. by the CIA and inside by the FBI's intelligence

³⁷ U.S. Dept. of Justice, Office of the Inspector General, *The Internal Effects of the Federal Bureau of Investigation's Reprioritization*, ch. 2 (Audit Report 04-39, Sept. 2004), <http://www.usdoj.gov.oig.reports/FBI/a0439/chw.htm>.

divisions. Yet the CIA and FBI have a history of mutual suspicion and antipathy.³⁸ This had begun to diminish even before 9/11, especially at the top of the two agencies. But the cultural and procedural gulf between criminal investigations and intelligence operations remains, and it impairs coordination between the two agencies just as it does within the FBI.

An agency 100 percent dedicated to domestic intelligence would do better at it than the FBI, which is at most 20 percent intelligence³⁹ and thus at least 80 percent criminal investigation and in consequence is dominated by the criminal investigators. That is why in the wake of 9/11, rather than create a separate national-security intelligence service within the FBI, the Bureau decided to give its special agents training in intelligence as well as in criminal investigation. This is a recipe for underspecialization and also has made it all the more likely that the ablest recruits will pursue careers as criminal investigators rather than as intelligence officers.

Not all the intelligence *analysts* in the FBI are special agents, it is true; but their selection and utilization are further evidence of the mismatch between intelligence and crime fighting. A number of the intelligence analysts reportedly have been recruited from the Bureau's clerical staff, have been given perfunctory training (lasting only five or seven weeks), and, not surprisingly in light of their origin and training, "are still asked to perform duties that are not analytical in nature, such as escort, trash and watch duty...Escort duty is following visitors, such as contractors, around the F.B.I. office to ensure that they do not compromise security. Trash duty involves collecting all 'official trash' to be incinerated. Watch duty involves answering phones and radios."⁴⁰

³⁸ See, for example, Mark Riebling, *Wedge: The Secret War between the FBI and the CIA* (1994).

³⁹ See note 64 below. It is true that one-third of the FBI's budget is allocated to intelligence, but the FBI's financial controls and reporting do not distinguish clearly between national-security and ordinary-crimes intelligence or between law-enforcement and intelligence responses to national-security threats.

⁴⁰ Eric Lichtblau, "F.B.I. Gets Mixed Review on Analysis," *New York Times* (national ed.), May 5, 2005, p. A22, quoting a report by the Justice Depart-

The effective control of an organization requires some minimum uniformity in compensation, recruitment, evaluation, promotion, and working conditions in order to minimize conflict, foster cooperation, and avoid confusion and uncertainty. If the missions assigned to the organization are too disparate—if their optimal performance requires radically different approaches, personnel, and so forth—then the compromise necessary to impose the requisite minimum uniformity may cause many of the missions to be performed poorly. If shoes came in only one size, they would be cheap to manufacture but most people would be poorly shod. Because criminal investigation is the dominant mission and prevailing culture of the Bureau, the inherent tensions between criminal investigation and national-security intelligence have continued even after the shock of 9/11 to be resolved in favor of the former.

But if, as my analysis implies, the FBI really “wants” to be a criminal investigation agency, how to explain its desire to dominate domestic intelligence? Why isn’t it happy to cede that function to a new agency? There are two reasons. The first is that a government agency that surrenders turf, even turf it doesn’t particularly want, signals weakness that may invite further raids by competing agencies, as the CIA is learning to its sorrow. Second, because counterterrorism is currently a national priority, an agency has budgetary and public-relations incentives to carve out an active role in it for itself. At the same time, because intelligence is an unpopular activity that stirs civil-liberties concerns at both the left and the right ends of the political spectrum and that yields fewer demonstrable successes than criminal prosecution, it is in the Bureau’s interest to continue to place greater emphasis on the arrest and prosecution both of terrorist suspects and of ordinary criminals than on intelligence operations.

The WMD Commission’s Critique. The objections to combining intelligence and criminal investigations in the same agency are not merely theoretical and comparative (other na-

ment’s Office of Inspector General. There could be no better evidence of the low status of intelligence in the FBI.

tions do it differently). They are also empirical. I gave some examples earlier. Here I want to focus on the scathing critique of the FBI by the WMD Commission led by former Senator Charles Robb and Judge Laurence Silberman. The report, which devotes almost an entire chapter to the FBI's post-9/11 performance,⁴¹ is even more critical of the Bureau than the 9/11 Commission's report had been. The reason may be that by the end of March 2005, when the WMD Commission issued its report, the FBI had had a full three and a half years since the 9/11 attacks to get its act together and, despite Mueller's efforts,⁴² had failed to do so. The failure was evident earlier. To quote Senator Shelby again,

Despite repeated reorganizations, the FBI has simply performed too poorly for the American people to have much faith in its ability to meet current and future challenges no matter how many aggressive "reform" plans are announced by FBI management. Even a year after Septem-

⁴¹ *Report of the Commission on the Intelligence Capabilities of the United States Regarding Weapons of Mass Destruction*, ch. 10 (Mar. 31, 2005).

⁴² Showcased in the Department of Justice report cited in note 20 above. This document, unsurprisingly, paints the FBI's efforts in the brightest possible hues. But it is unreliable. For example, it promised that the "Virtual Case File" system would be up and running within a year; within less than a year it was abandoned. Although the sunny report was submitted to Congress in April 2004, Mueller later testified that when the contractor "delivered the product [i.e., Virtual Case File] to us in December 2003, we immediately identified a number of deficiencies in VCF that made it unusable. Upon further examination [prior, however, to April 2004], we discovered nearly 400 problems with the software." Mueller, note 24 above, at 4. In like vein the FBI's parent, the Department of Justice, has been detected exaggerating the number of terrorist cases that it brings. U.S. General Accounting Office, "Report to the Honorable Dan Burton, House of Representatives: Justice Department: Better Management Oversight and Internal Controls Needed to Ensure Accuracy of Terrorism-Related Statistics," Jan. 2003, <http://www.gao.gov/new.items/d03266.pdf>; Mark Fazlollah, "Reports of Terror Crimes Inflated," *Philadelphia Inquirer*, May 15, 2003, <http://www.philly.com/mld/inquirer/5862945.htm>. (Notice that more than two years elapsed between these two reports, evidently without improvement.) See also Dan Eggen and Julie Tate, "In Terror Cases, Few Convictions: U.S. Often Depends on Lesser Charges," *Washington Post*, June 12, 2005, p. A1.

ber 11, in fact, the FBI's deputy director sent angry e-mail messages to Bureau field offices declaring that he was 'amazed and astounded' that the Special Agents in Charge (SACS) [of the field offices] *still* refused to commit essential resources to the fight against terrorism and *still* refused to share information properly with Headquarters.⁴³

The WMD Commission remarked politely that the FBI had made "significant" (not substantial) progress since 9/11, but gave no examples, while noting the Bureau's continued inability to acquire an adequate computer system and its chaotic organization, in which domestic intelligence is split up among three separate divisions (Intelligence, Counterterrorism, and Counterintelligence) and no one is in charge.

The commission reports that the FBI hopes to get its act together—but not until 2010, *at the earliest*.⁴⁴ The FBI's attitude, reflecting the domination of the Bureau by its scattered field offices, is typified by the remark of one of its officials that "Bin Laden is never going to Des Moines."⁴⁵ (So if Bin Laden is smart he'll attack Des Moines because we now know it's unprotected. And a successful attack on the heartland would be even more damaging to the morale of the American population as a whole than another attack on New York or Washington.) According to the commission, the Bureau has placed 96 percent of its intelligence budget in divisions that are not subject to the direct authority of the Director of National Intelligence and has given its Executive Assistant Director for Intelligence (a position not even filled until 18 months after 9/11 awoke the Bureau from its intelligence slumbers), who *is* subject to that authority, no power and virtually no staff. The commission notes the FBI's "continued failure"—this after three and a half years of ostensible striving—"to institute the reforms necessary to

⁴³ "September 11 and the Imperative of Reform," note 16 above, at 74–75.

⁴⁴ "Even FBI officials acknowledge that its collection and analysis capabilities will be a work in progress until at least 2010." *Report of the [WMD] Commission*, note 41 above, at 29. That "at least" is at once astonishing and ominous.

⁴⁵ *Id.* at 453.

transform the FBI into the intelligence organization it must become...The FBI has not constructed its intelligence program in a way that will promote integrated intelligence efforts, and its ambitions have led it into unnecessary new turf battles with the CIA.”⁴⁶ “While the FBI has made steps in the right direction since September 11, it has many miles to travel.”⁴⁷ (It takes many steps to add up to even one mile.) “Can the FBI’s latest effort to build an intelligence capability overcome the resistance that has scuppered past reforms? In our view, the effort this time is more determined, but *the outcome is still in doubt*.”⁴⁸

Before the Intelligence Reform Act changed things, the FBI’s Office of Intelligence was responsible mainly for training and recruitment, but not for operations, which were the responsibility of the Bureau’s Counterterrorism and Counterintelligence Divisions. The Act renamed the Office of Intelligence the Directorate of Intelligence and assigned it a variety of important tasks, including “supervision of all national intelligence programs, projects, and activities of the Bureau,”⁴⁹ but did not mention the other divisions. The Directorate of Intelli-

⁴⁶ Id. at 451.

⁴⁷ Id. at 468. “Reform will require enormous commitment and effort within the FBI, as well as sustained outside coordination and oversight.” Id. True; but there is insufficient commitment within the FBI, and, as a result, insufficient effort.

⁴⁸ Id. at 454 (emphasis added). The WMD Commission further criticized the FBI’s efforts to “reinvent” itself as an intelligence agency in a March 29, 2005, letter to President Bush, <http://www.wmd.gov/report/fbicia.pdf>. The letter remarks, for example, that “the FBI proposes to ‘integrate’ law enforcement and national security in a way that makes it impossible to establish an integrated national security workforce, which you [i.e., President Bush] called for in November and which we believe is essential to the security of this country” (p. 2). “The FBI recognizes what is needed to integrate these three national security missions [intelligence, counterintelligence, and counterterrorism], *and rejects it*” (id.; emphasis added). The letter thus comes close to accusing the FBI of defying the President. For still other criticism of the FBI as an intelligence agency, see Gabriel Schoenfeld, “How Inept Is the FBI?” *Commentary*, May 2002, p. 53.

⁴⁹ Intelligence Reform and Terrorism Prevention Act of 2004, Title II, § 2002(c)(1).

gence is still not in charge of the Bureau's national-security intelligence; the heads of the other two divisions don't report to its director. It corresponds, rather, to the CIA's Directorate of Intelligence (the analytic branch), while the Counterterrorism Division corresponds to the CIA's Directorate of Operations. This means that the FBI does not have *a* domestic intelligence service, but instead three services that have domestic intelligence responsibilities—and criminal-investigation responsibilities to boot. For the responsibility of the Directorate of Intelligence is not limited to intelligence concerning terrorist threats or other threats to national security; it is also responsible for intelligence about ordinary criminal activities within the Bureau's jurisdiction. And the Counterterrorism and Counterintelligence Divisions are engaged in arresting and gathering evidence for prosecuting terrorists and spies, as well as for pure intelligence and counterintelligence. This means that almost four years after 9/11, the Bureau *still* has not separated domestic intelligence from criminal investigation. It is noteworthy that the current head of the Counterterrorism Division, rather than being an intelligence professional, began his career as a police officer and since becoming an FBI special agent in 1983 had, until 2004, been involved in criminal investigations rather than in intelligence.⁵⁰ This is not an isolated case; for in recent testimony FBI officials have acknowledged that appointments to managerial positions in intelligence are made regardless of lack of any intelligence expertise⁵¹—which means that the criminal investigators will continue to dominate the Bureau's intelligence activity, as they are pretty much the only employees of the Bureau who have significant managerial experience.

II. THE “AGENCY WITHIN AN AGENCY” SOLUTION

Taking cognizance of this disarray, the WMD Commission recommended that the FBI fuse its three divisions that have intelligence responsibilities into a single entity within the FBI.

⁵⁰ “About Us: FBI Executives,” <http://www.fbi.gov/libref/executives/hulon.htm>.

⁵¹ John Solomon, “FBI View: Terror War Experience Unneeded,” *Kansas City Star*, June 20, 2005, pp. A1, A5.

The FBI has been reported to have accepted the recommendation “under pressure from the White House...The F.B.I.’s acceptance...represents a recognition within the bureau that it can no longer resist mounting pressures for change, after a series of scathing reports that have criticized it for intelligence lapses.”⁵²

This recognition, however coerced, is all to the good; and the proposed reorganization may prove to be an improvement over the present system, though this is uncertain; transition costs, exacerbated by foot-dragging by FBI career officials, may outweigh any benefits. As Senator Shelby noted in a passage that I quoted earlier, the FBI has repeatedly reorganized its intelligence operation, with little to show for these efforts. Furthermore—and here illustrating another deficiency of ad hoc commission studies, such as those of the 9/11 Commission and WMD Commission, namely a lack of historical perspective—the history of government reorganizations teaches that most such reorganizations fail, *especially* those imposed on an agency from the outside.⁵³ The FBI announced reorganizations of its intelligence operation in 1998, 1999, 2001, and 2002, and a further reorganization was decreed by the Intelligence Reform Act in 2004.⁵⁴ Can still *another* reorganization be what the doctor ordered?

The “agency within an agency” approach has a number of drawbacks, at least when viewed as an alternative rather than supplement⁵⁵ to creating a domestic intelligence agency that would be separate from the FBI:

1. Because the counterterrorism and counterintelligence divisions engage in criminal investigation as well as in intelli-

⁵² Johnston, note 10 above.

⁵³ Posner, *Preventing Surprise Attacks*, note 1 above, at 158–159.

⁵⁴ For a comprehensive discussion of the FBI’s efforts at intelligence reform, see Alfred Cumming and Todd Masse, *CRS Report for Congress: RL32336—FBI Intelligence Reform since September 11, 2001: Issues and Options for Congress* (Congressional Research Service, April 6, 2004), <http://www.au.af.mil/au/awc/awcgate/crs/rl32336.htm>.

⁵⁵ As I emphasize in Part III, the proposed reorganization of the FBI can coexist with the proposals discussed in that part, including the creation of a free-standing domestic intelligence agency.

gence, the new entity will not be an intelligence agency, but a hybrid; it will be like what would be brought about by merging MI5 with the Special Branch of Scotland Yard.

2. The head of the new entity will have an awful lot of bosses—the FBI’s director, the Attorney General, and the DNI. And given his relatively junior position as the third-ranked subordinate of an official (the FBI director—whose deputy is the number two man in the Bureau) who though a Presidential appointee is himself subordinate to a department head (the Attorney General), the head of the new unit will not be given, or if given be able to wield effectively, the coordination and command authority that, as argued in Part III of this paper, domestic intelligence requires.

The President is reported to have decided that the chief of the new agency will be a joint appointment by the FBI director and the DNI. This may lead to uncomfortable compromises, but in any event will show the chief that he indeed has two masters whom he will have to try to satisfy despite their divergent interests and perspectives.

3. The FBI director is likely to favor criminal investigation over intelligence even more than at present, because he will be in full charge of criminal investigation but only half in charge of intelligence.

4. When a vacancy occurs in the directorship of the FBI, there will be a cat fight over whether to fill it with an intelligence officer or with a criminal law enforcer. (In time of war or acute national emergency, the former would seem clearly the better choice, with his principal deputy a criminal law enforcer.)

5. Complex and time-consuming adjustments will be necessary to fuse the three divisions into a single, effective, stand-alone unit. Remember that the intelligence division is responsible for ordinary-crimes intelligence as well as for national-security intelligence and that the counterterrorism and counterintelligence units have law-enforcement as well as intelligence responsibilities. Remember too that the intelligence analysts are poorly selected and deployed and that the intelligence officers are in many cases recycled special agents hoping to cy-

cle back to the criminal investigation career track. What is required is not merely a combining of the three units under a single leader, but a complete shakeup of organization, personnel, training, and practices. Because of the difficulty of integrating the three intelligence units, the contemplated reorganization may end up as being little more than the interposition of a manager between the heads of the three units and the Bureau's director.

6. It is easier to start a new organization from scratch than to reorganize an existing organization. There is a long and on the whole successful history of starting new intelligence agencies *ex nihilo*, beginning with the OSS in 1942. In contrast, reorganizations of government agencies have, as I noted, a history of failure. A reorganization threatens existing staff, so is resisted and often in the process deformed, especially if staff has cultivated alliances with members and staff of Congress, as FBI officials have in fact long done. You can lead a horse to water, but you can't make him drink. Besides having to overcome passive and not so passive resistance by employees whose tenure or status the reorganization threatens, a reorganization disrupts work routines and scrambles lines of command, sowing confusion and disaffection that may take years to overcome.⁵⁶ Because creating a new agency would be easier than reorganizing the FBI, it would be a good insurance policy against the possible failure of that reorganization.

7. A related point is that creating a domestic intelligence service out of an existing criminal-investigation agency does nothing, at least in the short run, to change culture. The staff of the new entity will be the same staff that, imbued as it is with the Bureau's law-enforcement culture, has performed the intelligence function inadequately. (I give an historical example later.)

8. Unless the new agency within an agency is thoroughly encapsulated, it will be unable to disentangle itself from some of the worst features of the Bureau's present domestic intelli-

⁵⁶ Posner, *Preventing Surprise Attacks*, note 1 above, at 128–129; also reference in *id.* at 132 n. 11.

gence operation—such as the computer imbroglio. Will the new agency have to wait three and a half to four years to obtain a computer system optimized to domestic intelligence, which as we know is the FBI's current schedule? Or will it have to—would it be permitted—to develop its own system? If to be effective it will have to cut most of its ties to the rest of the Bureau, what advantage is gained by siting it in the Bureau? The disadvantages, as we have seen, are palpable.

9. The reorganization proposed by the WMD Commission may require legislation to implement. The Intelligence Reform Act creates the office of the Executive Assistant Director (of the FBI) for Intelligence, who is to head the Directorate of Intelligence, to which the Act assigns responsibility for “supervision of all national intelligence programs, projects, and activities of the Bureau.”⁵⁷ To place the directorate under an associate director of the Bureau is to displace the authority of the Executive Assistant Director for Intelligence; nor, under the proposed reorganization, would the Directorate of Intelligence authority be supervising, as the Act tells it to do, the intelligence operations of the counterterrorism and counterintelligence divisions. It is possible, as I'll suggest in Part III, that Congress does not have the authority to micromanage the organization of national-security agencies to the degree the Act attempts; but that is an open question, and uncertainty about the correct answer would cast a shadow over efforts to effectuate the reorganization purely by executive decree.

There are counterarguments, but they have limited force:

1. The most seductive is that we should first create a good domestic intelligence agency inside the FBI, see how it works, and then, if it turns out not to work, there will be time enough to lift it out of the Bureau (cutting along the dotted line, as it were, drawn by the reorganization) and make it a separate agency. Just the possibility of that happening, coupled with strong pressure from the President and the DNI, is a major

⁵⁷ Intelligence Reform and Terrorism Prevention Act of 2004, Title II, §§ 2002(b), (c)(1).

motivation for the Bureau's taking the need for change seriously.

But we can't afford the time that it would take to implement and evaluate a wait-and-see approach. The reorganization of the FBI will take time, probably months or even years, to implement fully, and during this protracted period of reorganization it will be impossible to say whether an effective domestic intelligence agency has been or is being created. If two years from now it's decided that the FBI has had its chance and has failed (and we have seen that there are powerful reasons to think this the likeliest outcome), we will have lost two years in dealing with what is probably a growing terrorist menace.

And if and when that does happen, the inevitable response will be to lift out the domestic intelligence agency from the FBI and make it its own agency. For what else is to be done with the agency? But that is not the way to go,⁵⁸ because the agency within the agency will take with it its police culture (the reason, no doubt, *why* it will have failed). There is a persuasive historical analogy. The Canadian domestic intelligence agency was formed from the security service of the Royal Canadian Mounted Police. I am informed that the service carried with it into its new home much of the culture of the RCMP, a police culture, and that this undermined the effectiveness of the new agency.

2. It might be thought that the prestige of the FBI, and its continued popularity among the general public despite its intelligence difficulties, would facilitate its recruitment of able candidates for its intelligence service. This seems unlikely, however. People who want to be intelligence officers don't want to be part of a police force, and that is the perception that will prevail even if the new agency within an agency is placed in a watertight capsule. Moreover, the Bureau is likely to encounter particular difficulty recruiting persons with the requisite lan-

⁵⁸ This represents a change of view for me. In chapter 6 of *Preventing Surprise Attacks*, note 1 above, I urged consideration of creating a domestic intelligence agency out of the intelligence components of the FBI. That now seems to me a mistake, for the reasons explained in the text.

guage skills, even though such persons are essential to the success of collecting and analyzing intelligence concerning the threat of international terrorism. The Bureau is feared and disliked by major elements of a crucial segment of the American public, namely the Arab-American and (overlapping) Muslim-American communities. Those are the principal communities in which are found people with the language skills required for counter-terrorist intelligence, but which the Bureau has tended in the aftermath of the 9/11 attacks to treat with a heavy hand, as in the incident involving the arrest of the two teenage would-be suicide bombers. Animosity toward the Bureau has frustrated efforts even to hire translators having the requisite languages and has left the Bureau with a mass of untranslated telephone intercepts that may contain clues to (serious, adult) terrorist plans.

3. Coordinating intelligence with criminal investigation of terrorist activities would in principle be facilitated by retaining the Bureau's current near monopoly of national-security intelligence. The importance of such coordination is undeniable. Criminal investigations are a vital tool of national security.⁵⁹ In holding that warrants issued pursuant to the Foreign Intelligence Surveillance Act for electronic or other surveillance may be used to gather evidence of criminal activity, the FISA review court went so far as to say that

arresting and prosecuting terrorist agents of, or spies, for, a foreign power may well be the best technique to prevent them from successfully continuing their terrorist or espionage activity. The government might wish to surveil the agent for some period of time to discover other participants in a conspiracy or to uncover a foreign power's plans, but typically at some point the government would wish to apprehend the agent and it might be that only a prosecution would provide sufficient incentives for the agent to cooperate with the government. Indeed, the

⁵⁹ Jeff Breinholt, "Seeking Synchronicity: Thoughts on the Role of Domestic Law Enforcement in Counterterrorism" (forthcoming in *American University International Law Review*).

threat of prosecution might be sufficient to “turn the agent.”⁶⁰

The court added, however, that “punishment of the terrorist or espionage agent is really a secondary objective.”⁶¹ That is wormwood to the FBI.

It is uncertain whether the necessary cooperation between intelligence officers and criminal investigators would be greater within an agency torn between two mutually suspicious services than between two agencies with carefully demarcated jurisdictions (though there is nothing wrong with some overlap to provide redundancy and competition): an agency that has domestic intelligence responsibilities but no law enforcement responsibilities, and a law enforcement agency that conducts intelligence operations primarily in support of criminal investigations. It is notable, and lamentable, that although the FBI is a part of the Justice Department, it takes an average of 46 days for the lawyers in the Department to present an application for a FISA warrant to the FISA court.⁶²

A section of the FBI that, like the Special Branch of Scotland Yard, was specialized to the arrest and prosecution of terrorists might make a better fit with a domestic intelligence agency than the FBI’s intelligence units make with the rest of the FBI, or will make when the intelligence units are combined and encapsulated. The FBI’s focus will always be on criminal investigation, not only as a matter of tradition and organizational culture but also because (one hopes) ordinary crime fighting will always require greater resources than domestic intelligence; there is more crime than there is terrorism, and it is costly to prepare a criminal prosecution. A person wanting a career in intelligence, I have suggested, will not be attracted to

⁶⁰ In re Sealed Case, 310 F.3d 717, 724 (U.S. Foreign Intelligence Surveillance Court of Review 2002). Though cast in terms of state-sponsored terrorism or espionage, the court’s analysis also has application to non-state actors, such as al Qaeda, though perhaps with diminished force, as suggested by the statistics and references in Eggen and Tate, note 42 above.

⁶¹ 310 F.3d at 744–745.

⁶² Eric Lichtblau, “Audit Finds Logjam in Efforts to Spy on Terror Suspects,” *New York Times* (late ed.), Apr. 28, 2005, p. A20.

working in a police department. It is different with someone wanting a career in the criminal investigation and prosecution of terrorists—a prestigious and exciting field of police work. Such a unit in the FBI could hold its head high and would at the same time have a strong incentive to cooperate with a domestic intelligence agency because that agency would be the source of many of the unit's prosecutions.

There is another reason that such an agency would not step on the FBI's toes more than occasionally. The agency's remit would be limited to intelligence concerning the gravest possible attacks on the nation—attacks that can fairly be regarded as threats to national security rather than as garden-variety criminal acts. The FBI, reflecting once again the influence of its law enforcement culture, classifies as “terrorism” virtually any politically motivated crime, much of which, such as attacks by the Animal Liberation Front on laboratories in which medical experiments are performed on animals, does not represent a threat to national security. Minor terrorists are a lot easier to catch and prosecute than major ones.

A domestic intelligence agency would be required to notify the Justice Department of serious criminal activity discovered in the agency's investigations even if the agency would prefer to avoid prosecution. The head of the agency would negotiate the disposition of the matter with the Attorney General.

4. Criminal investigators can assist in the core functions of a domestic intelligence agency; for example, as noted by the FISA review court, arrests can be used to extract information from a suspect or to turn him, as by threatening to tell his accomplices that he is cooperating with the authorities. But this is just another example of the need for a good working relationship between the new agency and a “Special Branch” type of unit within the FBI.

5. Criminal investigators have well-established criteria for what constitutes proof rather than mere grounds for suspicion, and familiarity with these criteria may prevent intelligence operatives from going off on wild goose chases. But this is just to say that a background in criminal investigation would be something a domestic intelligence service would want some of its

employees to have. That is different from having the service lodged in an agency that is headed by a judge or a prosecutor (the current FBI director is a former prosecutor, his immediate predecessor was a former judge, the judge's immediate predecessor was a prosecutor, and *his* immediate predecessor was another judge) and that conceives its principal mission to be the investigation and prosecution of the full range of federal crimes.

Furthermore, the rules of evidence that criminal law enforcers are required to study and master are not merely rules about separating proof from conjecture. Many of the rules are concerned with enforcing various evidence-suppressing privileges, such as the privilege against self-incrimination, and with shielding juries from evidence that they are believed incapable of evaluating correctly. These blinders placed on the pursuit of truth in litigation are not applicable to intelligence, which is not concerned with building a case and may thus be able to make fruitful use of conjectures. These are additional reasons for doubting that FBI special agents make the best intelligence officers.

The counterarguments actually underscore the fundamental limitation of the "agency within an agency" solution: If the new agency is truly encapsulated, the potential benefits from combining intelligence and criminal investigation in one agency—benefits that are at the core of the objections to creating a free-standing domestic intelligence agency—evaporate. There would be few if any greater obstacles to cooperation between two formally separate agencies than there would be between two agencies that, though nominally joined, were separated by a Chinese wall. Yet without such separation, all that will have been accomplished by the reorganization is a tighter integration of the intelligence, counterterrorism, and counter-intelligence units, and that is a "solution" unresponsive to the problems that gave rise to the WMD Commission's fusion proposal.

III. A BETTER SOLUTION

Coordination and Command. There are 17 federal intelligence agencies, scattered among different departments, with the principal exception of the CIA, whose director reports directly to the President rather than to a Cabinet member.⁶³ Prior to the Intelligence Reform Act, the different agencies, with the exception of those responsible for domestic intelligence (primarily the FBI), were loosely coordinated by the CIA's director in his dual capacity as Director of Central Intelligence (the DCIA was by law also the DCI). The Intelligence Reform Act both separates the two jobholders and augments the duties and, less clearly, the powers of the Director of Central Intelligence, renaming the post "Director of National Intelligence."

Figure 1 depicts the structure of the intelligence system before the Act was passed, and Figure 2 the altered structure that the Act ordains. Solid lines indicate full control ("line authority"); broken lines indicate limited control, influence, general supervision, or coordination. The agencies can be divided roughly into four groups: from left to right in the two charts they are military intelligence, technical intelligence, foreign intelligence, and domestic intelligence, with the intelligence services of the Treasury and Energy departments, plus the National Intelligence Council, straddling the foreign-domestic divide. Omitted from the charts, for the sake of simplicity, is the

⁶³ The canonical figure for the number of separate agencies is 15, but is incomplete. There are five military intelligence agencies (one for each of the four uniformed services, plus the Defense Intelligence Agency), three technical intelligence agencies (the National Reconnaissance Office, the National Security Agency, and the National Geospatial-Intelligence Agency), three domestic intelligence agencies (the FBI—treating its three intelligence-related divisions as one—plus two separate intelligence agencies in the Department of Homeland Security: the Directorate of Information Awareness and Infrastructure Protection and the Coast Guard's intelligence service); three foreign intelligence services (the CIA, the National Intelligence Council, and the State Department's Bureau of Intelligence and Research), and three that straddle domestic and foreign intelligence (the intelligence services of the Treasury and Energy departments and the National Counterterrorism Center). The NIC (National Intelligence Council) and the NCTC (National Counterterrorism Center), like the CIA, report to the President directly rather than to a department head.

National Counterterrorism Center (created by Presidential executive order in August of 2004), which includes representatives from the other intelligence agencies and thus, before the Intelligence Reform Act, provided the only formal linkage between the foreign and the domestic intelligence services.

FIGURE 1
THE INTELLIGENCE SYSTEM BEFORE
THE INTELLIGENCE REFORM ACT

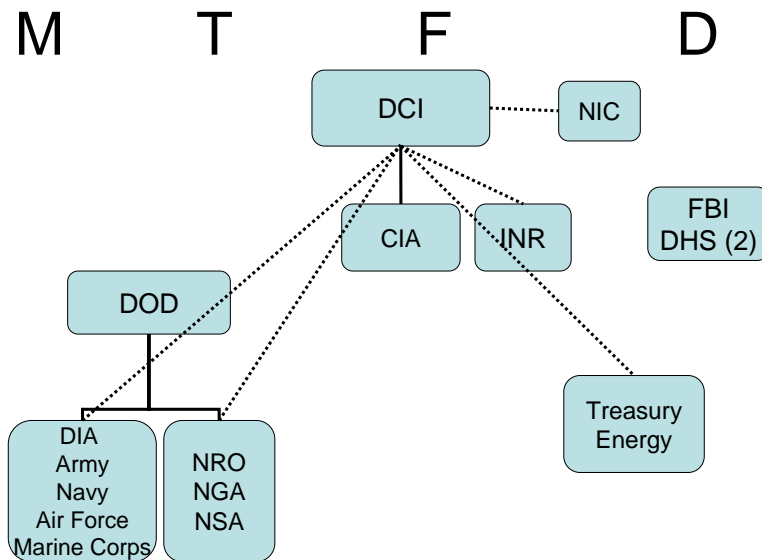
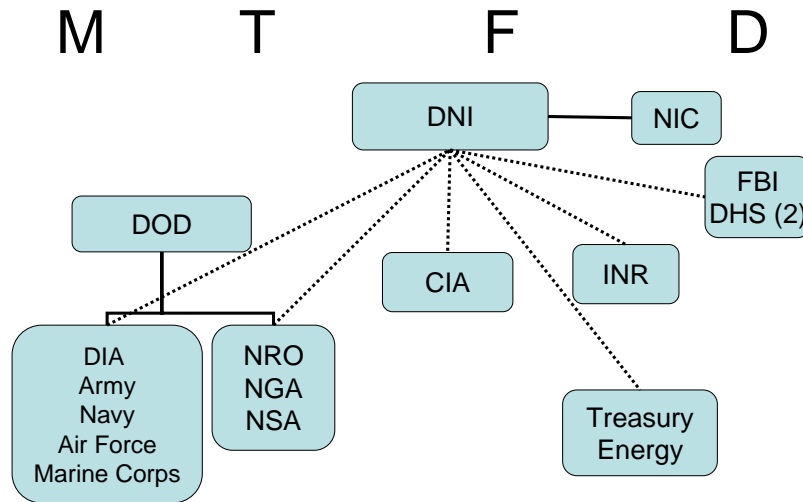

FIGURE 2
THE INTELLIGENCE SYSTEM AFTER
THE INTELLIGENCE REFORM ACT



The absence of effective coordination between domestic intelligence and foreign intelligence and among the various agencies involved in domestic intelligence was a weakness of the old regime. International terrorists operate both outside and inside the United States, moving back and forth across our porous borders.⁶⁴ The tracking of these terrorists requires close cooperation among the CIA, the FBI, local police forces, private companies (including security consulting firms), and various agencies now lodged in the Department of Homeland Security. The necessary cooperation was impeded because as I noted the Director of Central Intelligence lacked authority over domestic intelligence, a deficiency removed by the Intelligence Reform Act.

The Director of National Intelligence should consider appointing a deputy for domestic intelligence to coordinate the domestic intelligence services⁶⁵ with each other and with the

⁶⁴ By emphasizing international terrorism, I do not mean to depreciate the potential threat posed by home-grown terrorists; the prospect of a biological Unabomber, for example, is terrifying.

⁶⁵ It is an open question whether the authority of such an official should extend to the Treasury and Energy intelligence services, which conduct both domestic and foreign intelligence, though of a limited and specialized character. There is an argument, which I shall not try to pursue, for bringing

other federal intelligence services and the intelligence activities of local police departments, corporate security departments and other private security services.⁶⁶ An illustrative project for such a deputy would be the creation of a national training center for domestic intelligence. It would train not only federal intelligence officers, but also state and local officers, in order to create a comprehensive national network for collecting and exchanging domestic data. Probably, however, the institute should be lodged in the new agency, discussed next.

But I must be more precise about what “coordination” entails. It cannot mean just calling meetings at which representatives of different agencies give their views, the coordinator decides what should be done—and the agencies are free to treat his decision as nonbinding advice. Effective coordination requires a measure of command authority, enabling the coordinator to compel the sharing of information through access to a common database; to create and supervise the necessary inter-agency intelligence task forces; to establish an integrated national domestic intelligence network of federal, state, local, and private intelligence services; and to forge the necessary links to the other components of the federal intelligence community. Command authority is not line authority, however; the employees of the intelligence agencies other than the new domestic intelligence agency itself would not become employees of that agency.

The agencies that play a role in domestic intelligence are quite distinct. This is obvious in the case of the Coast Guard, the Treasury Department, and the Department of Energy, but it is also true of the DHS’s other (besides the Coast Guard) intelligence agency, the Directorate of Information Awareness and Infrastructure Protection, which has about 1,000 employ-

the Secret Service into the domestic intelligence community. The Secret Service has highly regarded intelligence capabilities that tend to be underutilized between Presidential election campaigns.

⁶⁶ The DNI has already “used up” the four deputy slots authorized to him by Congress, though the President probably has inherent authority to create another deputyship. (More on his inherent authority over national security shortly.) Anyway the title is not critical.

ees. The information-awareness function of IAIP involves communicating threat warnings to agencies that are in a position to do something about the threats and the infrastructure-protection function involves identifying the most vulnerable potential terrorist targets. Both are specialized aspects of domestic intelligence that require careful integration with the collection and analytical capabilities of the FBI and the other intelligence agencies.

A New Agency. The analysis in Part II indicates that a federal domestic intelligence agency should be created on the model of the domestic intelligence agencies of our foreign allies.

The Bureau resisted the WMD Commission's proposal to fuse its three intelligence-related divisions into one domestic intelligence agency because it saw (and sees) such fusion as a possible precursor to lifting that agency right out of the Bureau and making it free standing. That may be a realistic fear; but it would be a mistake to create a U.S. domestic intelligence agency in that fashion. Splitting the FBI would cause endless bureaucratic complexities and shatter morale; it would be the bureaucratic equivalent of a bitter divorce. Moreover, we don't have enough domestic intelligence officers. We need more (and better) and forming a new agency would create an opportunity to obtain them. Although the total staff of the five federal agencies with primarily domestic intelligence responsibilities (the FBI, the two intelligence agencies in DHS, and the intelligence units in the Treasury and Energy Departments) is not a published figure, it probably does not exceed 7,000, of whom 5,000 are in the FBI.⁶⁷ Remarkably, considering how much larger the

⁶⁷ I computed the figure for the FBI as follows: A recent audit report on the FBI by the Justice Department's Office of Inspector General, note 37 above, exh. 2-6, reveals that 2,811 of the FBI's agents assigned to field offices are engaged in terrorism-related work. The report indicates that roughly 200 headquarters agents are also engaged in such work and that about 500 headquarters support staff are engaged in counterterrorism and counterintelligence activities (computed from exh. 2-11). In addition, assuming that field support staff is proportional to the number of field agents, there are probably about 4,000 support personnel in the field offices who are supporting counterterrorism (calculated from exh. 2-2). That makes a total of some 7,500 (roughly a quarter of the entire staff of the FBI), but it is an over-

United States is than the United Kingdom, MI5, though tiny (2,000 employees), is almost 30 percent the size of the U.S. domestic intelligence community. Yet the United States has more than four times the population of the United Kingdom and, of greater significance, has much less control over its borders yet is confronted with graver, more varied, and more numerous threats.

By preserving the intelligence element of the FBI, the creation of a new agency would secure the efficiencies that FBI intelligence achieves by virtue of the Bureau's relations with local police forces (now formalized, in the counterterrorism area, in the Joint Terrorism Task Forces that I mentioned), its experience in terrorist prosecutions—for that matter, its experience, which is considerable if imperfect, in doing national-security intelligence—and the occasional overlaps of terrorist activity with ordinary crime. The need is to supplement the FBI's intelligence units with a new agency that will have a distinctive focus and culture, not to break up the Bureau.

The creation of a new agency would eliminate the need to force the Bureau to fuse its three intelligence-related divisions into one. The Bureau could be allowed to decide on the optimal structure of its intelligence service. It might decide that the costs in disruption that would be incurred in such a reorganization would exceed the benefits. Such a decision should probably be respected.

Although the FBI should continue to play the lead role in liaison with local police, a domestic intelligence agency would also have a significant role to play in this area. The rivalries among different law enforcement agencies are acute, as a result of competition for funds, overlapping authority, different

statement of the number of FBI employees engaged in domestic intelligence; for many of the analysts are engaged in ordinary-crimes intelligence and many of the special agents are engaged in criminal investigations of terrorist activities. I am guessing that only two-thirds—5,000—of the 7,500 are engaged in “pure” domestic intelligence, and this may well be an overestimate. As I noted in the text, moreover, much of the Bureau's counterterrorism activity, even some of its counterintelligence activity, may be concerned with only minor threats to national security.

cultures, the FBI's traditional hauteur, and fear of a rival agency's "stealing" one's cases. A pure intelligence agency, not linked to any law enforcement agency, would stand above the fray and be trusted as an honest broker—especially if it were authorized to devote a part of its budget to the support of intelligence-related costs of state and local law enforcement agencies, such as costs of information technology, training intelligence officers, and paying informants. In effect, the agency would be buying intelligence data from numerous police agencies that, with proper incentives, could collect a great deal of such data.

The creation of a U.S. domestic intelligence agency is usually called the "MI5 solution." MI5 is the best known of the foreign domestic intelligence agencies, and the United Kingdom is our closest ally. But a better model for a U.S. domestic intelligence agency from a public-relations standpoint (the importance of good public relations for a domestic intelligence agency should not be underestimated) is the Canadian domestic intelligence agency. (I quote its mission statement in the appendix to this paper.⁶⁸) MI5, throughout most of its long history, which began in 1909, operated without any judicial control, something that would be impermissible in the United States but seemed natural in the U.K. (which had no tradition of separation of powers); and violations of civil liberties were common. The use of a military acronym for a domestic intelligence agency ("MI" stands for "military intelligence")—even though MI5 has never actually been a part of the British armed forces⁶⁹—also strikes an ominous note. The Canadian Security Intelligence Service, itself modeled on MI5, does not have these drawbacks. It has no military overtones and is subject to an

⁶⁸ One of the missions that CSIS is assigned is conducting security clearances of applicants for government employment and screening immigrants. These are intelligence rather than law enforcement functions that in the United States are currently lodged in the FBI and DHS, respectively. They could be transferred to a domestic intelligence agency, but that is a peripheral issue that I shall not attempt to discuss in this paper.

⁶⁹ A. W. Brian Simpson, *In the Highest Degree Odious: Detention without Trial in Wartime Britain* 9 (1992).

elaborate set of controls⁷⁰ designed to prevent it from infringing civil liberties.

CSIS cannot be a complete model for a U.S. domestic intelligence agency. There are too many differences, particularly in population and perceived threats, between the United States and Canada. And I have no insights into the adequacy of CSIS's funding or the quality of its management, personnel, or operational methods.⁷¹ It is the concept and basic design of the agency that seem to me an attractive template for a U.S. domestic intelligence agency.

A Modest Alternative. If creating a U.S. domestic intelligence agency seems too radical a step, an alternative would be for the DNI to appoint a deputy who would exercise the coordination powers that I have sketched but whose staff would include intelligence analysts, case officers, security officers, translators, weapons experts, and database managers and thus would have operational as well as staff capabilities. The purpose would be both to augment the deputy's command and coordination authority and to provide a benchmark for evaluating the performance of the domestic intelligence services, just as the Tennessee Valley Authority was created in part to be a benchmark for evaluating the performance of private electrical utilities. This staff would be a nascent domestic intelligence agency and thus a prod to as well as a monitor of the FBI's lagging efforts. As a new entrant to the intelligence scene, it would be in a good position to experiment with improved intelligence practices, such as a shorter replacement cycle for information technology, greater use of statistical and economic techniques (such as cost-benefit analysis) of threat assessment, and more flexible hiring practices. The conflict of interest objection would be muted because the new unit (though for reasons of esprit de corps it might be called an agency or service) would be the deputy's staff. The FBI could no more object to the deputy's having a staff than any of the intelligence agen-

⁷⁰ See the CSIS home page under "Accountability and Review," at http://www.csis-scrs.gc.ca/eng/backgrnd/back1_e.html.

⁷¹ For criticism, see "Epidemic of Espionage," *Newsbeat 1*, June 19, 2005, <http://newsbeat1.com/2005/06/epidemic-of-espionage.html>.

cies can object to the DNI's having a staff—of which the deputy's staff would be a part.

Sitting the New Agency; the DHS Option. If a domestic intelligence agency is created, it could be a stand-alone agency like the CIA (that is, not owned by any Cabinet-level department), reporting, as the CIA now does (except for covert operations, which would not be a proper function of a domestic intelligence agency⁷²), to the DNI. Alternatively, it could be lodged in the Department of Homeland Security, just as MI5 reports to the Home Secretary, who corresponds to the Secretary of DHS, and just as the director of the Canadian Security Intelligence Service reports to the Minister for Public Safety and Emergency Preparedness.

DHS is reported to be considering creating a “centralized homeland-intelligence office.”⁷³ Conceivably this could be the domestic intelligence agency advocated in this paper, although apparently something considerably more modest is envisaged.⁷⁴ Apart from conforming to established practice in nations that we consider our peers, lodging such an agency in the Department of Homeland Security would have a number of advantages. It would interpose an official (the Secretary of DHS) who

⁷² The term “covert operations” refers to operations, often involving physical force, which because of their illegality or violation of moral principles are considered permissible only when used against foreigners in foreign countries, and even then must be kept in deep enough secrecy to enable the President and other policymakers to plausibly deny knowledge of the operations. An intelligence agency would not be permitted to use such tactics on American soil, though it would be permitted to use methods of surveillance and penetration, lawfully used in criminal investigations, and nonviolent disruptive activities such as disinformation and other deceptive practices, exposure, and bribery, subject to appropriate safeguards to ensure the protection of privacy, free speech, and other legal rights.

⁷³ Robert Block, “Homeland Security Wrestles with Revamp: Big Changes Appear on Hold as Chertoff Tries to Trim Bureaucracy, Mold Counterterror Force,” *Wall Street Journal*, June 13, 2005, p. A4. As I noted earlier, the existing DHS intelligence services are limited to specialized aspects of intelligence.

⁷⁴ Lara Jakes Jordan, “Homeland Security Faces Massive Overhaul,” June 17, 2005, <http://www.washingtonpost.com/wp-dyn/content/article/2005/06/17/AR2005061701092.html>.

is not an intelligence officer between the domestic intelligence agency and the President, something civil libertarians strongly favor. It would place the domestic intelligence agency in a department that has a clear mission of preventing terrorist attacks within the United States, rather than a police mission, and that, unlike the FBI, has no J. Edgar Hoover legacy. Placing the agency in DHS would facilitate the coordination of DHS's massive intelligence-related information sources (including Immigration and Customs Enforcement, the Transportation Security Administration, the Border Patrol, and the Secret Service). It would also foster closer coordination of domestic intelligence with the antiterrorism programs of DHS (that is, programs aimed at preventing or responding to terrorist attacks, as distinct from predicting such attacks), though it would do so at the price of added managerial complexity, since the head of the domestic intelligence agency would report both to the Secretary of DHS and to the DNI.

The size of DHS may seem to argue against placing still another agency in it. Yet size can have offsetting advantages. DHS is so large that it could relocate a sufficient number of its existing employees to free up the necessary office space for the new agency, could provide basic administrative staff and seed money, and in this and other ways could shorten the period of time necessary to make the new agency fully operational.

If this route were followed, the Under Secretary of DHS for Information Awareness and Infrastructure Protection could be redesignated the Under Secretary for Intelligence and placed in charge of the new domestic intelligence agency, into which the Information Awareness and Infrastructure Protection Directorate would be merged. As a subcabinet officer, the Under Secretary for Intelligence would have the status necessary to deal on terms of equality with the director of the FBI's intelligence service.

He could also double as the DNI's deputy for domestic intelligence—the 9/11 Commission had proposed that either the chief intelligence officer of DHS or the chief intelligence officer of the FBI be dual hatted as the DNI's deputy for domestic intelligence. Giving the same person line authority over the do-

mestic intelligence agency and coordination authority over the other elements of domestic intelligence would replicate the “dual hatting” of the CIA’s director (he was both DCI and DCIA), but it would do so on a much smaller, and therefore a manageable, scale. It would be a scale comparable to the dual hatting of the DNI’s deputy for intelligence analysis, who doubles as the director of the National Intelligence Council.

Granted, it would also create a perceived institutional conflict of interest. Competing agencies would fear that the dual hatter would favor “his” agency, in much the same way that the DCI was suspected of favoring the CIA and so encountered resistance to his efforts to manage the intelligence community as a whole. On balance, however, it would be better to have the same person both direct the new agency and be the DNI’s deputy for domestic intelligence (and thus exercise, by delegation from the DNI, the coordination authority that I have described), at least in the early stages of the new agency. This would give the official greater clout in his dealings with the FBI (and he would need that) and also minimize friction and hierarchy.

Finding a Role; Relation to Other Agencies. I anticipate the objection that the structure of the U.S. intelligence system that is emerging from the Intelligence Reform Act and its implementation by the Director of National Intelligence leaves no room for a domestic intelligence agency separate from the intelligence services of the FBI and the specialized intelligence services of DHS, Energy, and Treasury. The DNI has deputies for analysis and collection, not limited to foreign intelligence, while the National Counterterrorism Center, established last summer, is flexing its muscles and has recently been described as “the nation’s primary agency for analyzing terrorist threats and planning counterterrorism operations *at home* and abroad.”⁷⁵

What is left for a domestic intelligence agency to do? A great deal: collecting intelligence data directly, by human and

⁷⁵ Walter Pincus, “Counterterrorism Center Awaits Presidential Action: Director and Chain of Command Are Needed by June 17,” *Washington Post*, June 3, 2005, p. A21 (emphasis added).

technical means (and also from open-source materials), within the United States, more adroitly than the FBI, with its criminal investigation mentality is capable of doing (the NCTC is not a collection agency); collecting such data indirectly, by creating and maintaining, through training and other means, a nationwide network of domestic agencies—federal, state, local, and private—that collect or can be encouraged to collect domestic intelligence data (including the protection agencies within DHS, such as the Border Patrol, the Coast Guard, Immigration and Customs Enforcement, and the Transportation Security Administration); pooling, sorting, matching, etc., data collected by the agency both directly and indirectly with data from other federal intelligence agencies (and this is another thing such an agency could do better than the IT-challenged FBI); sharing data with other intelligence agencies on demand; analyzing data and using that analysis and analysis of infrastructure vulnerabilities to make threat assessments; issuing threat warnings to “first responders” and other interested agencies; and conducting the very limited, nonviolent disruption operations that would be proper for a domestic intelligence agency.⁷⁶

All this would be done under the general supervision of the Office of the DNI and of the NCTC. But there is a danger that the ability of the director of the domestic intelligence agency to initiate timely intelligence operations, whether to collect intelligence or to disrupt terrorist plots, would be impaired by his having to obtain clearances from multiple levels of higher authority. (NCTC is not a part of the Office of the DNI.) That could be a formula for delay and for diffusion of responsibility and control. If the head of a new domestic intelligence agency were a different person from the deputy DNI for domestic intelligence, this would add another layer of control; so here is another argument for the dual hatting that I have suggested.

Getting Started. It is possible that the system of domestic intelligence sketched above could be created by Presidential executive order alone. Much of it, indeed, could be created by

⁷⁶ See note 72 above.

the Director of National Intelligence by interpretation of the Intelligence Reform Act. Take so trivial-seeming a provision as “the Director of National Intelligence shall ensure the elimination of waste and unnecessary duplication within the intelligence community.”⁷⁷ This seems a fatuous exhortation. Yet on the plausible theory that legislation, like the Constitution itself, implicitly confers on an agency the powers “necessary and proper” to enable it to fulfill the duties expressly imposed upon it by the legislation, the provision could be interpreted to authorize the DNI to exercise such authority as may be necessary (required) and proper (lawful) to eliminate waste and unnecessary duplication. That authority may be considerable. (Thus can congressional efforts to micromanage the executive branch backfire.) But I do not think it would extend to the point of allowing him to establish an entire agency; nor would it be desirable to have the new agency that I have proposed actually be a part of the Office of the DNI. That would create an especially acute institutional conflict of interest; the deputy DNI for national intelligence would not merely wear two hats (as head of the new agency and as coordinator-commander of the domestic intelligence community as a whole); the entire new agency, and not just its director, would be a part of the DNI’s staff.

Beyond any implications found in the Intelligence Reform Act itself, the authority conferred on the President by Article II of the Constitution to command the armed forces and direct foreign policy, and thus to take charge of national defense and national security, of which intelligence was a recognized component long before the drafting of the Constitution,⁷⁸ should empower the President to create, combine, separate, and reconfigure components of the intelligence system without congressional authorization. Conceivably, his authority in these regards may not even be subject to congressional override, be-

⁷⁷ Intelligence Reform and Terrorism Prevention Act of 2004, § 1011(a), adding section 102(a)(f)(5) to the National Security Act of 1947, 50 U.S.C. § 403A(f)(5).

⁷⁸ It is on a similar theory that the President’s power to authorize covert operations by the CIA has been found in Article II. *The Intelligence Community: History, Organization, and Issues* 9 (Tyrus G. Fain ed. 1977).

yond what is implicit in Congress's control of the federal budget. And what is implicit in that control may be less than what we have become accustomed to. "As President of the United States from 1789 to 1797, [George] Washington took personal responsibility for foreign intelligence...Congress required him to certify what sums he had spent, but allowed him to conceal both the purposes and recipients of payments from the fund."⁷⁹ The largest of the intelligence agencies, the National Security Agency, was created by Presidential executive order rather than by an Act of Congress.⁸⁰ Indeed, most U.S. intelligence services were first created that way, a recent example being the creation last summer of the National Counterterrorism Center.

All this said, prudence recommends seeking authorization for a domestic intelligence agency from Congress, if only because of the civil-liberties concerns that the creation of such an agency would engender. I argue below that these concerns are greatly exaggerated; but they are a political fact that cannot be ignored.

The creation of a new national-security agency from the ground up may seem a daunting undertaking. But that depends on the size of the agency, on the degree to which its operation depends on complex and expensive technologies, and maybe also on where it is placed in the government structure. Given the existence of other federal domestic intelligence agen-

⁷⁹ Christopher Andrew, *For the President's Eyes Only: Secret Intelligence and the American Presidency from Washington to Bush* 11 (1995).

⁸⁰ *The Intelligence Community*, note 78 above, at 351 (statement of Lt. Gen. Lew Allen, Jr., Director, National Security Agency), 519. See also John D. Bansemer, "Intelligence Reform: A Question of Balance" (Harvard University Center for Information Policy Research, Program on Information Resources Policy, Apr. 18, 2005), http://pirp.harvard.edu/pubs_pdf/banseme/banseme-draft-05.pdf, at 36, describing significant changes in the organization of the intelligence system made in 1972 by President Nixon without congressional authorization. For helpful introductions to the legal issues mentioned in the text, see Russell J. Bruemmer, "Intelligence Community Reorganization: Declining the Invitation to Struggle," 101 *Yale Law Journal* 867 (1992); David Everett Colton, Comment, "Speaking Truth to Power: Intelligence Oversight in an Imperfect World," 137 *University of Pennsylvania Law Review* 571 (1988).

cies (for remember that I am not suggesting any curtailment in the FBI's intelligence operations), the aid in collection, analysis, and technical services that the new domestic intelligence agency proposed here would receive from the CIA, the NSA, the National Counterterrorism Center, and other foreign and technical intelligence services within the overall federal intelligence community, and the intelligence resources of the nation's numerous police forces both public and private, the new agency would not have to be large, and its only major nonpersonnel expense would be the purchase of communications and information-technology equipment; this expense, I have suggested, would be modest.

A total staff of 2,000 or even 1,000 might suffice for the new agency (the former number would presumably be the minimum if the agency were lodged in the Department of Homeland Security and the Information Awareness and Infrastructure Protection Directorate were merged into it). An agency of such modest size might under vigorous leadership be operational within a few months, at least if certain rules governing procurement (for example of a computer system) and housing (the requirement that security-related buildings be hardened against various forms of attack, such as truck bombing, can make office space hard to obtain in the short run) could be relaxed for the new agency. I have suggested that placing the agency in the Department of Homeland Security would facilitate a prompt launch. The department is vast and both physical space and budgetary resources, along with a nucleus of experienced administrative staff, might be found within it to equip a start-up agency with minimal difficulty, expense, and delay.

The Civil-Liberties Question. Any strengthening of domestic intelligence capabilities is bound to draw complaints from civil-liberties advocates because surveillance of groups and individuals outside the criminal process gives rise to legitimate concerns about possible infringements of privacy and of freedom of speech. In evaluating such complaints, one must distinguish two issues. The first is where the boundary should be drawn between security and liberty concerns, an issue I have

addressed elsewhere.⁸¹ The farther out from core security concerns the boundary is pushed and thus the more flexibility a domestic intelligence agency would have, the less temptation the agency would have to cross the boundary. The second issue is whether, wherever the boundary is drawn, a domestic intelligence agency should or will cross it. It should not cross it because it would be illegal to do so and would expose the personnel of the agency to civil and criminal sanctions. And it is unlikely to cross it because to do so would be profoundly imprudent from the agency's own standpoint, and this for two reasons. First, given the civil-liberties concerns to which the creation of such an agency would give rise, and the fragility of any new, small agency, any infractions of constitutional liberties would probably doom the experiment. Second, a domestic intelligence agency could not afford to alienate the large Arab and Muslim communities in the United States by infringing the civil liberties of the members of these communities. As I have already suggested, the agency would depend critically on their cooperation in informing on any terrorists or terrorist sympathizers in their midst; and if they became disaffected to the point of actively assisting terrorist activities, the nation's terrorist problem would be compounded enormously.

An important distinction to bear in mind is between the overall size of the domestic intelligence system and the location of a particular agency within it. To the extent that domestic intelligence does place pressure on civil liberties, that pressure presumably is greater the more domestic intelligence officers (databases, etc.) there are. But there is no doubt that the number is going to grow; domestic intelligence is seriously undermanned. Whether it grows by expansion of the FBI or by starting up a new agency is probably unrelated to the ultimate size that will be attained, but if anything the former route will conduce to a greater overall growth in domestic intelligence simply because there is less opposition by civil libertarians to expand-

⁸¹ Posner, *Preventing Surprise Attacks*, note 1 above, at 185–196; Posner, note 2 above, at 224–243; Richard A. Posner, *Law, Pragmatism, and Democracy* 293–317 (2003).

ing the FBI than to the establishment of a separate domestic intelligence agency.

There should not be. It requires a lapse of historical memory to think that an FBI monopoly of domestic intelligence is any kind of guarantee of respect for civil liberties. As revealed by the Church Committee, until the mid-1970s the FBI, despite being a part of the Justice Department and therefore nominally subordinate to the nation's chief legal officer, repeatedly committed serious infringements of civil liberties in pursuit of its domestic intelligence mission, such as its relentless electronic surveillance of Martin Luther King, Jr.'s private life.⁸²

Indeed, a domestic intelligence agency "might offer advantages over our current structure even in terms of civil liberties...I suspect that most Americans...would feel safer having [domestic intelligence] collection performed by intelligence officers who do *not* possess coercive powers—and who can only actually take *action* against someone through a process of formal coordination with law enforcement officials."⁸³ This suggestion is corroborated by the incident I mentioned earlier in which two teenage girls were arrested on suspicion of planning to become suicide bombers. The fear and indignation that the arrests engendered in their families and in their ethnic community were enhanced by the fact that they were imprisoned, coupled with the fact that, because the investigation was intelligence-related, the FBI, to protect its sources, could not give a full and convincing account of the reasons for its actions.⁸⁴

What is important is not that domestic intelligence be controlled by the FBI, but that it be subject to legal and administrative controls intelligently designed to check abuses. Here there many possibilities: (a) lodging the new agency in the Department of Homeland Security, so that, as mentioned earlier,

⁸² *The Intelligence Community*, note 78 above, ch. 12; *Intelligence Activities and the Rights of Americans*, Final Report of the U.S. Sen. Select Comm. to Study Government Operations with Respect to Intelligence Activities, Bk. II, S. Rep. No. 755, 94th Cong., 2d Sess. (1976).

⁸³ "September 11 and the Imperative of Reform," note 16 above, at 75.

⁸⁴ Nina Bernstein, "Questions, Bitterness and Exile for Queens Girl in Terror Case," *New York Times* (national ed.), June 17, 2005, pp. A1, A20.

there would be an official who was not an intelligence officer between the agency and the White House; (b) creating a domestic intelligence oversight board composed primarily of lawyers with civil-liberties expertise, (c) assigning special oversight responsibilities with respect to domestic intelligence to the civil-liberties board that the Intelligence Reform Act requires be established in the Office of the DNI; (d) subjecting the new agency to the guidelines drafted by the Attorney General to regulate the FBI's intelligence operations; (e) creating a steering committee for the new agency, composed of the Attorney General, the Director of National Intelligence, and the Secretary of Homeland Security, to oversee the new agency; (f) incorporating controls similar to those that Canada has placed over CSIS, (g) suggesting that Congress lodge oversight responsibility for domestic intelligence either in the Senate Homeland Security and Government Affairs Committee (and its House counterpart)—which presumably would be the automatic consequence of placing the agency in the Department of Homeland Security—rather than in the intelligence committees, or in a new joint committee for domestic intelligence, (h) appointing as the agency's director someone from outside the intelligence and national-security communities,⁸⁵ (j) limiting the jurisdiction of the new agency to the collection and analysis of intelligence relating to politically motivated (as distinct from ordinary criminal) activities that threaten to cause major loss of life or comparable harm to the public welfare, and (k) reminding the relevant public: (i)—a point overlooked by the 9/11 Commission in opposing the creation of a domestic intelligence agency—that *all* public employees in the United States are subject to civil and criminal penalties for violating the Constitution and laws, (ii) that the greatest setback that could happen to civil liberties in the United States would be the occurrence of another terrorist attack as big or bigger than 9/11, and (iii) that the public safety is as much a constitutional value as personal liberty is. Indeed, a possible name for a domestic in-

⁸⁵ Probably a judge or other lawyer, to facilitate coordination with the FBI and to reassure that legal constraints on domestic intelligence will be respected.

telligence agency would be “Office for the Protection of the Constitution,”⁸⁶ though a less cumbersome alternative, borrowed from the Canadians, would be “Security Intelligence Service.”

I am led by this analysis to conclude that the real though unacknowledged reason the civil libertarians want the FBI to continue to dominate domestic intelligence may be that to the extent the Bureau’s conduct of intelligence is likely, for the reasons that I have explained, to be ineffectual, the threat to civil liberties is minimized.

CONCLUSION

Domestic intelligence in the United States today is undermanned, understudied, undersupervised, uncoordinated, technologically challenged, tied too closely to criminal law enforcement, and (the same point, really) dominated by an agency (the FBI) that, because its primary activity is law enforcement, is structurally unsuited to play the central role in domestic national-security intelligence—and all this at a time of extreme danger and vulnerability. A terrorist who wants to enter the United States can do so with relative ease either with forged documents or by being smuggled across the Canadian or Mexican borders. The U.S. government has to be able to find, follow, watch, overhear, deceive, bribe, and expose (and not just arrest and prosecute) suspected terrorists plus groups and individuals that assist them by providing safe houses, financing, weapons, or other forms of support. To this end it must collect and compare and analyze masses of data concerning foreign visitors, plants where weapons are made and stores where they are sold, laboratories where lethal pathogens and toxins are stored, locations and shipments of radioactive materials, potential targets, and much else besides. Nor can the threat posed by homegrown terrorists in the era of weapons of mass destruction be ignored.

⁸⁶ This is an almost literal translation of the name of Germany’s domestic intelligence service—Bundesamt für Verfassungsschutz. It resembles CSIS. See <http://www.fas.org/irp/world/germany/bfv/ops.htm>.

Reorganizing the FBI cannot be the complete answer, given the deep tension that I have stressed between criminal investigation and national-security intelligence. There is urgent need for a domestic intelligence agency, modeled on the Canadian Security Intelligence Service, that would be separate from the FBI and would have no authority to engage in law enforcement. Such an agency would not draw staff from the FBI; the Bureau would retain its existing intelligence operation, whether or not reorganized. Whether the new agency was free standing (that is, not owned by any Cabinet-level department), or, as I am inclined to prefer, lodged in the Department of Homeland Security, its director should probably be dual hatted by the Director of National Intelligence as his deputy for domestic intelligence. In that capacity he would be charged with exercising command authority over all federal domestic intelligence services and with coordinating them with the other intelligence services both inside and outside the federal intelligence community.

Appendix: Mission Statement of the Canadian Security Intelligence Service⁸⁷

The Canadian Security Intelligence Service (CSIS) was created by an Act of Parliament in 1984, following the McDonald Commission of Inquiry in the late 1970s and the Mackenzie Commission of the 1960s. The *CSIS Act* established a clear mandate for the Service and, for the first time, legislated a framework of democratic control and accountability for a civilian Canadian security intelligence service.

In meeting its mandated commitments, CSIS provides advance warning to government departments and agencies about activities which may reasonably be suspected of constituting threats to the country's security. Other departments and agencies, not CSIS, are responsible for taking direct action to counter security threats.

⁸⁷ The source of this statement is CSIS's home page: http://www.csis-scrc.gc.ca/eng/backgrnd/back1_e.html.

CSIS does not have law enforcement powers, therefore, all law enforcement functions are the responsibility of police authorities. The splitting of functions, combined with comprehensive legislated review mechanisms, ensures that CSIS remains under the close control of the federal government.

In its early years, much of the Service's energy and resources were devoted to countering the spying activities of foreign governments. Time has passed however, and as the world has changed, so has CSIS.

In response to the rise of terrorism worldwide and with the demise of the Cold War, CSIS has made public safety its first priority. This is reflected in the high proportion of resources devoted to counter-terrorism. CSIS has also assigned more of its counter-intelligence resources to investigate the activities of foreign governments that decide to conduct economic espionage in Canada so as to gain an economic advantage or try to acquire technology in Canada that could be used for developing weapons of mass destruction.

Along with these operational changes, CSIS has matured into an organization with a flexible, dynamic structure and, most importantly, an ingrained understanding of its responsibilities and obligations to Canadians. The Service's main purpose is to investigate and report on threats to the security of Canada. This occurs within a framework of accountability to government, as well as respect for the law and the protection of human rights. Nowadays, it also means being more open and transparent to the people it serves. There are some limits on what the Service can discuss; that is the nature of its work, but CSIS is anything but a secret organization.

The Canadian way of life is founded upon a recognition of the rights and freedoms of the individual. CSIS carries out its role of protecting that way of life with respect for those values. To ensure this balanced approach, the *CSIS Act* strictly limits the type of activity that may be investigated, the ways that information can be collected and who may view the information. The *Act* provides many controls to ensure adherence to these conditions.

Information may be gathered, primarily under the authority of section 12 of the *CSIS Act*, only about those individuals or organizations

suspected of engaging in one of the following types of activity that threaten the security of Canada, as cited in section 2:

1. *Espionage and Sabotage*

Espionage: Activities conducted for the purpose of acquiring by unlawful or unauthorized means information or assets relating to sensitive political, economic, scientific or military matters, or for the purpose of their unauthorized communication to a foreign state or foreign political organization.

Sabotage: Activities conducted for the purpose of endangering the safety, security or defense of vital public or private property, such as installations, structures, equipment or systems.

2. *Foreign-influenced Activities*

Foreign-influenced activities: Activities detrimental to the interests of Canada, and which are directed, controlled, financed or otherwise significantly affected by a foreign state or organization, their agents or others working on their behalf.

For example: Foreign governments or groups which interfere with or direct the affairs of ethnic communities within Canada by pressuring members of those communities. Threats may also be made against relatives living abroad.

3. *Political Violence and Terrorism*

Threat or acts of serious violence may constitute attempts at compelling the Canadian government to respond in a certain way. Acts of serious violence cause grave bodily harm or death to persons, or serious damage to or the destruction of public or private property, and are contrary to Canadian law or would be if committed in Canada. Hostage-taking, bomb threats and assassination attempts are examples of acts of serious violence that endanger the lives of Canadians. Such actions have been used in an attempt to force particular political responses and change in this country.

Exponents and supporters of political, religious or ideological violence may try to use Canada as a haven or a base from which to plan or facilitate violence in other countries.

Such actions compromise the safety of people living in Canada and the capacity of the Canadian government to conduct its domestic and external affairs.

4. Subversion

Subversion: Activities intended to undermine or overthrow Canada's constitutionally established system of government by violence. Subversive activities seek to interfere with or ultimately destroy the electoral, legislative, executive, administrative or judicial processes or institutions of Canada.

Lawful Protest and Advocacy

The *CSIS Act* prohibits the Service from investigating acts of advocacy, protest or dissent that are conducted lawfully. CSIS may investigate these types of actions only if they are carried out in conjunction with one of the four previously identified types of activity. CSIS is especially sensitive in distinguishing lawful protest and advocacy from potentially subversive actions. Even when an investigation is warranted, it is carried out with careful regard for the civil rights of those whose actions are being investigated.

Security Screening

As well as investigating the four types of threats to Canadian security, CSIS provides security assessments, on request, to all federal departments and agencies with the exception of the Royal Canadian Mounted Police (RCMP), which conducts its own. These assessments are made with respect to applicants for positions in the Public Service of Canada requiring a security clearance, and for immigration and citizenship applicants.

Security Assessments

The purpose of security assessments is to appraise the loyalty to Canada and reliability, as it relates thereto, of prospective govern-

ment employees. The intent of the exercise is to determine whether persons being considered for security clearances are susceptible to blackmail or likely to become involved in activities detrimental to national security, as defined in section 2 of the *CSIS Act*. The assessments serve as a basis for recommending that the deputy head of the department or agency concerned grant or deny a security clearance to the individual in question. Security assessments are conducted under the authority of sections 13 and 15 of the *CSIS Act*.

The designated manager in the department or agency determines the security clearance level required for the position to be filled, in accordance with the standards set out in the Government Security Policy. CSIS then conducts the appropriate checks. The duration and depth of the investigation increase with the clearance level.

Immigration and Citizenship

Sections 14 and 15 of the *CSIS Act* authorize the Service to provide security assessments for the review of citizenship and immigration applications to the Department of Citizenship and Immigration.

The assessments provided by the Service for this purpose pertain to the provisions of section 2 of the *CSIS Act* that deal with threats to the security of Canada. The Department of Citizenship and Immigration uses these assessments to review immigration applications in accordance with the inadmissibility criteria set out in the *Immigration and Refugee Protection Act*. On 1 February 1993, this *Act* was amended to include, the terms "terrorism" and "members of an organization". This measure has increased the pertinence of CSIS assessments. Moreover, the inadmissible classes now include, in section 19(1)(f), persons who have engaged, or are members of an organization that has engaged, in acts of terrorism or espionage.

The same practice is followed for citizenship applications. They too are examined on the basis of the definition of threats to the security of Canada set out in section 2 of the *CSIS Act*, and security assessments are provided under section 19 of the *Citizenship Act*.

Questions & Answers

How and when was CSIS created?

CSIS was created by the passage of an Act of Parliament (Bill C-9) on June 21, 1984. The Service began its formal existence on July 16, 1984.

What does CSIS do?

CSIS has a mandate to collect, analyze and retain information or intelligence on activities that may on reasonable grounds be suspected of constituting threats to the security of Canada and in relation thereto, report to and advise the Government of Canada. CSIS also provides security assessments, on request, to all federal departments and agencies, with the exception of the RCMP.

What organization collected security intelligence before CSIS was created?

Prior to June 21, 1984, security intelligence was collected by the Security Service of the RCMP. CSIS was created because the Government of Canada, after intensive review and study, came to the conclusion that security intelligence investigations would be more appropriately handled by a civilian agency. CSIS has no police powers. However, CSIS works with various police forces on those investigations that have both national security and criminal implications. Although CSIS can offer assistance to the police, it has no mandate to conduct criminal investigations.

What constitutes a threat to the security of Canada?

The complete threat definitions can be found in section 2 (a,b,c,d) of the *CSIS Act*. Simply put, terrorism (the planning or use of politically motivated serious violence) and espionage (undeclared foreign intelligence activity in Canada and detrimental to the interests of Canada) are the two major threats which CSIS investigates. Terrorism and espionage can have criminal implications. In such cases, the RCMP investigates and can lay the appropriate criminal charges.

What is "security intelligence" and does the government really need it given that technology allows news broadcasters to deliver information from around the world in a matter of minutes?

Security intelligence is information formulated to assist government decision-makers in developing policy. Regardless of the source of intelligence, it provides value in addition to what can be found in other government reports or in news stories. Intelligence conveys the story behind the story.

How does CSIS obtain this "value-added" component?

The "value-added" comes from analysis and a wide variety of investigative techniques, including the use of covert and intrusive methods such as electronic surveillance and the recruitment and tasking of human sources.

Can these techniques be arbitrarily deployed?

No. All intrusive methods of investigation used by CSIS are subject to several levels of approval before they are deployed. The most intrusive methods—such as electronic surveillance, mail opening and covert searches—require a warrant issued by a judge of the Federal Court of Canada. In addition, the Security Intelligence Review Committee and the Inspector General closely review CSIS operations to ensure they are lawful and comply with the Service's policies and procedures.

What does CSIS do with the security intelligence it collects?

CSIS reports to and advises the Government of Canada. CSIS intelligence is shared with a number of other federal government agencies and departments, including the RCMP and the departments of Foreign Affairs, International Trade, Citizenship and Immigration, and of National Defence. As well, CSIS has arrangements to exchange security-related information with other countries. The vast majority of these arrangements deal with visa vetting. A small number deal with exchanges of information collected by CSIS in its investigation of threats to national security.

What is the difference between a security intelligence service and a foreign intelligence service?

A security intelligence service is restricted to investigating threats to its country's national security. A foreign intelligence service, on the other hand, conducts offensive operations for its government in foreign countries. The methods and objectives of foreign intelligence services differ from country to country.

Does CSIS have any foreign presence at all?

CSIS has liaison offices in some countries. Liaison officers are involved in the exchange of security intelligence information which concerns threats to the security of Canada.

Does CSIS investigate industrial espionage?

CSIS does not investigate company-to-company industrial espionage. CSIS does, however, investigate the activities of foreign governments that engage in economic espionage as a means of gaining an economic advantage for themselves. Economic espionage can be defined as the use of, or facilitation of, illegal, clandestine, coercive or deceptive means by a foreign government or its surrogates to acquire economic intelligence.

What is the impact of foreign government economic espionage activity on businesses in Canada?

Foreign government economic espionage activity exposes Canadian companies to unfair disadvantage, jeopardizing Canadian jobs, Canada's competitiveness and research & development investment.

Does CSIS conduct investigations on university campuses?

CSIS is very sensitive to the special role that academic institutions play in a free and democratic society and the need to preserve the free flow of ideas, therefore, investigations involving university campuses require the approval of senior officials in the Service. Furthermore, human sources and intrusive investigative techniques may only be used with the approval of the Minister for Public Safety and Emergency Preparedness.

Can you name individuals or groups currently under CSIS investigation?

The *CSIS Act* prevents the Service from confirming or denying the existence of specific operations. To disclose such information would impede the Service's investigative capabilities which, in turn, would be injurious to national security. CSIS, however, can assure the public that it is doing everything within its mandate to ensure that Canadians are safeguarded from terrorism and foreign espionage.

Given that the Cold War is over, are there still threats with which Canadians should be concerned?

Yes. Details regarding the Service's view of the security intelligence environment can be found in its annual Public Reports.