

Halkos, George E. (Ed.)

Book

Current issues in natural resource and environmental economics

Economies

Provided in Cooperation with:

MDPI – Multidisciplinary Digital Publishing Institute, Basel

Suggested Citation: Halkos, George E. (Ed.) (2023) : Current issues in natural resource and environmental economics, Economies, ISBN 978-3-0365-6260-5, MDPI, Basel, <https://doi.org/10.3390/books978-3-0365-6260-5>

This Version is available at:

<https://hdl.handle.net/10419/279847>

Standard-Nutzungsbedingungen:

Die Dokumente auf EconStor dürfen zu eigenen wissenschaftlichen Zwecken und zum Privatgebrauch gespeichert und kopiert werden.

Sie dürfen die Dokumente nicht für öffentliche oder kommerzielle Zwecke vervielfältigen, öffentlich ausstellen, öffentlich zugänglich machen, vertreiben oder anderweitig nutzen.

Sofern die Verfasser die Dokumente unter Open-Content-Lizenzen (insbesondere CC-Lizenzen) zur Verfügung gestellt haben sollten, gelten abweichend von diesen Nutzungsbedingungen die in der dort genannten Lizenz gewährten Nutzungsrechte.

Terms of use:

Documents in EconStor may be saved and copied for your personal and scholarly purposes.

You are not to copy documents for public or commercial purposes, to exhibit the documents publicly, to make them publicly available on the internet, or to distribute or otherwise use the documents in public.

If the documents have been made available under an Open Content Licence (especially Creative Commons Licences), you may exercise further usage rights as specified in the indicated licence.



<https://creativecommons.org/licenses/by-nc-nd/4.0/>



economies

Current Issues in Natural Resource and Environmental Economics

Edited by

George Halkos

Printed Edition of the Special Issue Published in *Economies*

Current Issues in Natural Resource and Environmental Economics

Current Issues in Natural Resource and Environmental Economics

Editor

George Halkos

MDPI • Basel • Beijing • Wuhan • Barcelona • Belgrade • Manchester • Tokyo • Cluj • Tianjin



Editor

George Halkos
University of Thessaly
Greece

Editorial Office

MDPI
St. Alban-Anlage 66
4052 Basel, Switzerland

This is a reprint of articles from the Special Issue published online in the open access journal *Economies* (ISSN 2227-7099) (available at: https://www.mdpi.com/journal/economies/special_issues/nature_environment_economics).

For citation purposes, cite each article independently as indicated on the article page online and as indicated below:

LastName, A.A.; LastName, B.B.; LastName, C.C. Article Title. <i>Journal Name</i> Year , <i>Volume Number</i> , Page Range.
--

ISBN 978-3-0365-6259-9 (Hbk)

ISBN 978-3-0365-6260-5 (PDF)

© 2023 by the authors. Articles in this book are Open Access and distributed under the Creative Commons Attribution (CC BY) license, which allows users to download, copy and build upon published articles, as long as the author and publisher are properly credited, which ensures maximum dissemination and a wider impact of our publications.

The book as a whole is distributed by MDPI under the terms and conditions of the Creative Commons license CC BY-NC-ND.

Contents

About the Editor	vii
Preface to "Current Issues in Natural Resource and Environmental Economics"	ix
Gianluigi Cisco and Andrea Gatto Climate Justice in an Intergenerational Sustainability Framework: A Stochastic OLG Model Reprinted from: <i>Economies</i> 2021, 9, 47, doi:10.3390/economies9020047	1
Jeremiás Máté Balogh and Tamás Mizik Trade–Climate Nexus: A Systematic Review of the Literature Reprinted from: <i>Economies</i> 2021, 9, 99, doi:10.3390/economies9030099	15
Enrico Maria Mosconi, Andrea Colantoni, Filippo Gambella, Eva Cudlinová, Luca Salvati and Jesús Rodrigo-Comino Revisiting the Environmental Kuznets Curve: The Spatial Interaction between Economy and Territory Reprinted from: <i>Economies</i> 2020, 8, 74, doi:10.3390/economies8030074	35
Elwasila Saeed Elamin Mohamed Resource Rents, Human Development and Economic Growth in Sudan Reprinted from: <i>Economies</i> 2020, 8, 99, doi:10.3390/economies8040099	55
Rafael Villa and Andrés Monzón Mobility Restrictions and E-Commerce: Holistic Balance in Madrid Centre during COVID-19 Lockdown Reprinted from: <i>Economies</i> 2021, 9, 57, doi:10.3390/economies9020057	77
Tatyana Ponomarenko, Oksana Marinina, Marina Nevskaya and Kristina Kuryakova Developing Corporate Sustainability Assessment Methods for Oil and Gas Companies Reprinted from: <i>Economies</i> 2021, 9, 58, doi:10.3390/economies9020058	97
David A. Anderson Environmental Exigencies and the Efficient Voter Rule Reprinted from: <i>Economies</i> 2020, 8, 100, doi:10.3390/economies8040100	119
George E. Halkos and George J. Papageorgiou Some Results on the Control of Polluting Firms According to Dynamic Nash and Stackelberg Patterns † Reprinted from: <i>Economies</i> 2021, 9, 77, doi:10.3390/economies9020077	127
Vít Pászto, Jarmila Zimmermannová, Jolana Skaličková and Judit Sági Spatial Patterns in Fiscal Impacts of Environmental Taxation in the EU Reprinted from: <i>Economies</i> 2020, 8, 104, doi:10.3390/economies8040104	141
Anbes Tenaye New Evidence Using a Dynamic Panel Data Approach: Cereal Supply Response in Smallholder Agriculture in Ethiopia Reprinted from: <i>Economies</i> 2020, 8, 61, doi:10.3390/economies8030061	159
Henning Wilts, Marina Fecke and Christine Zeher Economics of Waste Prevention: Second-Hand Products in Germany Reprinted from: <i>Economies</i> 2021, 9, 74, doi:10.3390/economies9020074	183

Peter Tshepiso Ndhlovu, Abiodun Olusola Omotayo, Adeyemi Oladapo Aremu and Wilfred Otang-Mbeng

Herbal-Based Cosmeceuticals and Economic Sustainability among Women in South African Rural Communities

Reprinted from: *Economies* **2020**, *8*, 51, doi:10.3390/economies8030051 **193**

About the Editor

George Halkos

George Halkos (MA, MSc, PhD) is Professor in Economics of Natural Resources. He has worked as a team leader and research fellow in various research and academic institutions, such as the University of Piraeus, the Athens University of Economics (former ASOEE), the University of the Aegean, the Stockholm Environment Institute, the Panteion University, the ATEL, etc., for research projects financed by the European Union (PHARE programs), the Hellenic Republic Ministry of Development, the National Statistical Service of Greece, the EUROSTAT, the Ministry of Employment, etc.

He has contributed to and presented articles at International Conferences. He acts as a referee in various scientific journals. He is the Director of the Operations Research Laboratory. He was Associate Editor of the journals *Environment and Development Economics* (Cambridge University Press) for six years.

His research interests are in the fields of applied statistics and econometrics, simulations of economic modelling, natural resource and environmental economics, applied micro-economic with emphasis in welfare economics, air pollution, game theory, mathematical models (non-linear programming).

Preface to “Current Issues in Natural Resource and Environmental Economics”

This Special Issue collects twelve studies that explore current issues concerning the environment and sustainability. The selected papers review and investigate various issues such as the nexus between trade and climate, the spatial interaction between economy and territory, climate justice in an intergenerational sustainability framework, resource rents, human development and economic growth in the case of Sudan as well as the mobility restrictions and e-commerce in the case of Madrid Centre during the COVID-19 lockdown. At the level of firms, there is a study about the development of corporate sustainability assessment methods for oil and gas companies followed by the environmental exigencies and the efficient voter rule.

In a game theory setup, one study presents some results on the control of polluting firms in dynamic Nash and Stackelberg patterns. Two other works refer to spatial patterns and the fiscal impacts of environmental taxation in the EU and the provision of new evidence on cereal supply response in smallholder agriculture in the case of Ethiopia. Finally, we have present two more studies on the economics of waste prevention concerning second-hand products in the case of Germany and economic sustainability among women in South African rural communities in the case of herbal-based cosmeceuticals.

Let us then consider each study in particular. The research of Cisco and Gatto focuses on the interrelations of sustainability and climate justice based on the use of the overlapping generations (OLG) model under an intertemporal framework. The central aim of the study was to identify the necessary conditions for sustainable development under climate justice imperatives between generations. The researchers called for reduced leisure and consumption patterns as a move away from the business-as-usual scenario for reducing emissions and their impact on the environment. Ultimately, enhanced intergenerational sustainability and climate change will flourish.

The research of Balogh and Mizik on the trade-climate nexus elucidates the potential of trade agreements to help countries to achieve their climate goals. The review focused on papers of the period of 2010 to 2020 and specifically on issues of the effectiveness of trade agreements, different national interests, emission leakage, and protectionism. The main conclusion of the paper was that the largest GHG-emitting countries (China, US, EU) are gaining more from trade negotiations than developing countries. In conclusion, the literature review provided a series of policy practices that might reduce emissions and provide incentives for climate mitigation policies.

The study conducted by Mosconi et al. focused on the revision of the Environmental Kuznets Curve (EKC) based on the spatial interaction between economy and territory in order to broaden the choice of efficient management solutions. The EKC identifies the relations between the degradation of nature and the level of income of an economic system, especially in terms of the governmental policies in high-income countries. However, the authors emphasized the potential for improving the role of space in EKC, specifically in terms of the impact of spatial variability on the nexus between income and environment. Briefly, the proposed multi-scale investigation of degradation processes at the local level might incorporate more traditional, cross-country, and cross-region practices. In short, spatial scales are important parameters in ecological economics.

The study of Mohamed shed light on the relationship between natural resource rents, human development, and economic growth in Sudan during 1970–2015. The conducted analysis was achieved by using co-integration and vector error correction modelling (VECM). The first tests confirmed a long-run equilibrium between the studied parameters. Moreover, the second tests

showed positive relationships (except one parameter); nevertheless, this pattern changed in the long run. Furthermore, a long-run Granger causality test demonstrated a causal relationship between the study's parameters. In conclusion, the study proposed more governmental support on natural resource rents for a sustainable future in Sudan, via the creation of virtuous economic circles between human development and economic growth.

The study of Villa and Monzón focused on the importance of urban logistics on sustainability imperatives during the era of COVID-19, when phenomena emerged, such as a change in urban mobility and an increase in e-commerce. The case study area was Madrid Central, where the results showed a significant decrease in transportation in comparison to the pre-COVID-19 era. The delivered parcels increased substantially because of Light Commercial Vehicles (LCV) which satisfied package delivery needs. To recapitulate, the period of COVID-19 posed a challenge to urban logistics, in response to which attempts were made to impose new mobility models in large cities with high volumes of e-commerce deliveries. This study by Ponomarenko et al. concerns the decreasing production at oil and gas facilities and necessitates the development of new operating fields. Briefly, there are changes in states' policies because of novel offshore projects of private companies, which paved the way especially for corporate social responsibility (CSR) companies. This was achieved via two sustainable development indicators. The proposed methodology showed that oil and gas companies differ significantly in terms of corporate sustainability, making clear that such indicators provide practical significance to a company's CSR planning.

In the paper of Anderson, the environmental exigencies and the role of the "efficient voter rule" are displayed. Policymakers have sought mechanisms that coordinate private incentivization and societally urgent conditions, concerning the internalization of individual's behavior impacts. Nevertheless, Anderson concluded that recent remedies to effectively manage such externalities failed to provide satisfactory results. Finally, it is advisable that a simple voting mechanism to achieve socially optimal decisions under uncertainty be imposed.

In this paper, Halkos and Papageorgiou monitored the conflict between the group of polluting firms, and any social planners who aimed to control the emissions generated during the production process. Both require different processes in terms of the control policies' standards (maximization for firms; minimization for social planners). This paper belongs to the special class of differential games, also known as, 'state separable differential games'. The cornerstone of these games is the coincidence of the Nash equilibrium with the Markovian equilibrium; furthermore, in the case of hierarchical moves, analytical solutions could be obtained easily. Moreover, a sensitivity analysis was developed for the model's crucial variables. Lastly, a comparison between the two types of equilibrium for the game showed the conflict's intensity for cases in which the polluting firms act as the leader in the hierarchical move game.

The study by Pászto et al. observed the possible spatial patterns in environmental and fiscal impacts on public budgets of EU countries for the years 2008 and 2017, via the grouping according to their environmental taxation performance. Based on two cluster analysis (CA) methods, Ward linkage and K-nearest neighbors (spatial) CA, potential geographical links were observed. Consequently, in 2008 the countries were naively grouped into "the West and "the East", as the West had higher environmental tax revenues in comparison to the east. However, in 2017 these borderlines were blurred because of the high diversification between the countries, in terms of environmental taxation on national budgets.

In the paper of Tenaye the importance of increasing agricultural production in developing countries and specifically in Ethiopia is described. The examined period spanned the years 1994-2009 and the study investigated the dynamic supply responses of major cereal crops to price and nonprice

factors. The results showed the influence of both the planted areas and produced yields of major crops by the aforementioned factors, in parallel with farmers' capability of analyzing market signals and responding accurately to alterations in prices of staple crops. The author also concluded that the growth of Ethiopian agriculture could be based partly on the the augmentation of agricultural prices. Briefly, it is advisable that a fine-tuned balance be developed between government intervention and market solutions, which might ultimately improve yield production via reformed agronomic practices.

The specific study concluded that 'reuse' remains a "niche phenomenon" and that consumers seem to waste economic opportunities associated with the buying and selling of second-hand products in Germany. Hence, the research by Wilts et al. sheds light on the incentives and barriers of second-hand product markets and applies a theoretical background of transaction costs to explain the existing consumption patterns. Waste of valuable unused products in households occurs because of barriers in the transition to sustainable consumption. Furthermore, the study exhibited the paradox that consumers buy new products, although they are aware that second-hand products save money and promote climate protection.

The economic potential(s) of the natural herbal-based cosmetic and cosmeceutical enterprise was the focus of the study regarding the improvement of Vhavenda women's welfare. Using a purposive sampling technique with 79 Vhavenda women, a descriptive and an inferential (Tobit regression) statistical analysis was performed, in addition to a budgeting analysis. As a result, the study by Ndhlovu et al. can provide considerable outcomes regarding this marginalized herbal-based cosmetic and cosmeceutical enterprise.

George Halkos

Editor

Article

Climate Justice in an Intergenerational Sustainability Framework: A Stochastic OLG Model

Gianluigi Cisco¹ and Andrea Gatto^{2,3,4,*}

¹ Department of Economic and Legal Studies, University of Naples “Parthenope”, 80132 Naples, Italy; gianluigi.cisco@uniparthenope.it

² Natural Resources Institute, Livelihoods & Institutions Department, University of Greenwich, Central Avenue, Chatham Maritime ME4 4TB, UK

³ Centre for Studies on European Economy (AIM), Azerbaijan State University of Economics (UNEC), Baku AZ1001, Azerbaijan

⁴ CED—Center for Economic Development and Social Change, Via Guido De Ruggiero, 80128 Napoli, Italy

* Correspondence: a.gatto@greenwich.ac.uk

Abstract: Climate justice is conceived as the intertemporal climate equity and equality exchange amongst generations. Sustainability—intended as the interplay amongst the economy, the society, the environment, and the governance—is essential to forge the climate justice theoretical framework. On this base, the study attempts to model the intertemporal choice of the status quo amongst generations in these four domains, making use of an overlapping generations (OLG) model making use of an intertemporal choice framework. The proxies detected are GDP growth (economy), environmental quality (environment), and labor growth, and environmental investment (society) as assumptions. The governance dimension is captured by the difference in wealth between young and old generations. The work aims at replying to the following research question: *Which are the conditions for sustainable development such that climate justice holds?* The intra-intergenerational exchange is defined in two periods, while the individual provides their preferred economic and environmental choice mix as consumption-saving. This study shows that keeping the business-as-usual scenario, young generations will have to bear the brunt of sustainable development. Additionally, reduced emissions are only achievable with increased efforts by the youth by reducing their leisure and consumption. These facts call for enhanced intergenerational sustainability and climate justice policies.

Keywords: overlapping generations; climate justice; technology shock; environmental quality; OLG model; intergenerational sustainability; commons; resource governance

Citation: Cisco, Gianluigi, and Andrea Gatto. 2021. Climate Justice in an Intergenerational Sustainability Framework: A Stochastic OLG Model. *Economies* 9: 47. <https://doi.org/10.3390/economies9020047>

Academic Editor: George Halkos

Received: 16 January 2021

Accepted: 26 February 2021

Published: 1 April 2021

Publisher’s Note: MDPI stays neutral with regard to jurisdictional claims in published maps and institutional affiliations.



Copyright: © 2021 by the authors. Licensee MDPI, Basel, Switzerland. This article is an open access article distributed under the terms and conditions of the Creative Commons Attribution (CC BY) license (<https://creativecommons.org/licenses/by/4.0/>).

1. Introduction

Climate justice is nowadays an ecological and societal conundrum having major implications on public health (Introcaso 2018). Climate justice calls for urgent governance actions targeting climate change adaptation (Sovacool 2013). The issue became paramount in the international forums with the COP21 and major climate change and environmental protection summits (Gatto 2020; IPCC 2018; Rhodes 2016), and got popularity after a series of climate strikes, climate activism, and civil society unrest—whereby Greta Thunberg became the most renowned representative of a primarily youth-driven movement (Rutter 2019). Climate justice is closely connected with energy and resource justice, sustainable development, and the common pools resources theory (Jenkins 2018; Bickerstaff et al. 2013). Climate justice calls for vulnerability protection (Shue 2014), where resilience actions to tackle resources sustainability are detected as priorities (Agovino et al. 2018).

In this sense, climate justice firstly calls for energy resilience strategies and policies to face vulnerability and empower the vulnerable (Gatto and Busato 2020; Gatto and Drago 2020a, 2020b). Climate justice is an interdisciplinary issue, to be tackled with a multidimensional approach (Roser et al. 2015). Climate justice reckons on climate change—and its mitigation and protection. Climate justice has been conceived in different ways by

previous scholarship. In terms of resource governance, it has been catalogued as either a global public good or a commons due to its intergenerational attributes and the conflicts affecting the different cohorts—being either rival or nonrival in its use (Ostrom 2015; Shaffer 2012; Ostrom 2010; Nordhaus 2006; Grasso 2004; Kaul et al. 2003; Kelleher 2000; Nordhaus 1994). However, it shall be noticed that the two goods categories are often confused or even interpreted as synonyms (Brando et al. 2019). For this reason, climate needs tailored governance and policy actions to achieve its most effective use and benefit.

Climate vulnerability and resilience are hot button topics in the international development agenda. This is particularly relevant for issues related to natural resources management, the energy–food–water nexus and overall climate change (Campbell et al. 2018; Agovino et al. 2018). In 2015, the Sustainable Development Goals (SDGs) have settled 17 goals and 169 targets to tackle poverty and achieve sustainable development in OECD and least developed countries (United Nations (UN) 2015). In this framework, the need for promoting climate resilience policies to face climate change vulnerability issues plays a crucial role (Brenkert and Malone 2005). The world has become more vulnerable to a series of shocks and adverse events, especially regarding natural hazards. These stylized facts concerning climate change vulnerability affect often the most vulnerable categories, countries and minorities e.g., people with disabilities, refugees and migrants, poor, women, youth, and rural people (Agovino et al. 2018; Gatto et al. 2016; Picot and Moss 2014).

To the best knowledge of this research's authors, no scholarship modeling climate justice has been published so far yielding a clear potential for research novelty. Nevertheless, the literature on climate change modeling is broad. Weitzman (2009) analyzed the economic implications of climate change calamities. Sen (2008) stressed the importance of renewable energy and the atmosphere for climate change. The concept of climate as a commons was modeled by Nordhaus (1994). Brenkert and Malone (2005) emphasized the role of vulnerability and resilience to climate change. Martens (2013) connected climate change with health studies, examining the effects of ozone depletion and global warming. Xu (2000) studied the effects of climate change on water governance. Koca et al. (2006), examined natural ecosystems impact, focusing on Sweden.

At the same time, the authors are not aware of further applications of OLG models to climate justice. OLG models have been utilized for disentangling climate–economy interactions by Howarth (1998). Stephan et al. (1997) modeled infinitely lived agents as for the economics of global warming. Sachs (2014) oriented a climate change OLG model on global warming and intergenerational wellbeing. Schneider et al. (2012) focused on the trade-offs amongst generations in a continuous-time. John and Pecchenino (1994) were most concerned about the existing connections between growth and the environment. Bayer and Cansier (1996) scrutinized the issue through the lens of systematic intergenerational discounting. Gerlagh and Keyzer (2001) developed an OLG model to draw a scenario analysis based on possible resource management and intertemporal environmental choices rendering diverse policy outcomes.

This work assumes climate justice coming from the intergenerational climate equity and equality, being deliverable solely through an ethical, sustainable approach (Stern and Taylor 2007; Francis 2015; McKinnon 2015; UNESCO 2014). In this regard, sustainability requires the simultaneous combination of a balanced economic, social, environmental, and governance mix. Holding these conceptual premises, the study attempts to contribute to the existing theoretical literature on climate justice, offering a model to theorize the intertemporal choice amongst generations in these four domains. For such scope, it is exploited an overlapping generations (OLG) model. Thus, it is proposed as a research question: *Which are the conditions for sustainable development such that climate justice holds?* The study has previously explored the phenomenon of climate justice and interconnected vulnerability and resilience issues, drafting a review on climate change modeling. The paper's remainder is as follows: Section 2 presents the OLG model developed in this study, focusing on the welfare measure and competitive equilibrium. Thus, Section 3 provides the calibration and steady-state conditions, whereas Section 4, investigates the impulse re-

sponse analysis. Therefore, Section 5 drafts the works conclusions and policy implications, sketching the paper’s limitations and future research.

2. The Model

This section shows the main features of the OLG modeling. This work is based on intertemporal choice theory—hence, it relies on rational expectations. The aim is to sketch the status quo of climate justice and intertemporal sustainability to better depict the two phenomena and their interplay. In terms of modeling, the paper paves the way for comparisons between classic OLGs and OLGs complemented with the environment—that is already quite an innovative item. As in the standard [Diamond \(1965\)](#) OLG model, this study considers an overlapping generations model in which each consumer lives two periods: young and old.

2.1. Consumers

In each period $t > 0$, a new generation of identical consumers is born. The size of generation t is given by $N_t = (1 + n)^t$, with $n > 0$. All consumers have one unit of time endowment, which can be allocated between work and leisure. Retirement is obligatory in the second period of life, so the labor supply of old consumers is zero. Consumers—both young and old—benefit from environmental quality. The latter is not considered a control variable—it is indirectly improved through investments that produce beneficial effects only after a period of time. Consider a consumer who is born at time $t \geq 0$. Let $c_{y,t}$ and $c_{o,t+1}$ denote his consumption when young and old, respectively, l_t denote his labor supply when young, and Q_t is the environmental quality index. The consumers’ preferences are represented by:

$$U_t(c_{y,t}, l_t, Q_t, c_{o,t+1}, Q_{t+1}) = \frac{c_{y,t}^{1-\sigma}}{1-\sigma} + A \frac{Q_t^{1-\sigma_e}}{1-\sigma_e} - B \frac{l_t^{1+\psi}}{1+\psi} + \beta \left(\frac{c_{o,t+1}^{1-\sigma}}{1-\sigma} + A \frac{Q_{t+1}^{1-\sigma_e}}{1-\sigma_e} \right), \quad \sigma_i \neq 1 \tag{1}$$

$$U_t(c_{y,t}, l_t, Q_t, c_{o,t+1}, Q_{t+1}) = \ln(c_{y,t}) + A \ln(Q_t) - B \frac{l_t^{1+\psi}}{1+\psi} + \beta [\ln(c_{o,t+1}) + A \ln(Q_{t+1})], \quad \sigma_i = 1 \tag{2}$$

where $\sigma > 0$ and $\sigma_e > 0$ are measures of risk aversion, $\psi > 0$ is the inverse of the Frisch elasticity of labor supply, $\beta \in (0, 1)$ is the subjective discount factor, A and B are positive constant parameters representing the weight given to environmental quality relative to private consumption and the weight given to work’s disutility, respectively. The environmental quality at time $t + 1$ (measured by the environmental index Q) is degraded by consumption of the old at time t and improved by environmental investments, m_t . As in [John and Pecchenino \(1994\)](#) and [Angelopoulos et al. \(2010, 2013\)](#), we assume the following functional form:

$$Q_{t+1} = (1 - \delta_q)\bar{Q} + \delta_q Q_t - P_t + \phi m_t \tag{3}$$

where \bar{Q} represents environmental quality without pollution, P_t is the current pollution flow, m_t is private spending on abatement activities, ϕ is the environmental spending converter, and $\delta_q \in (0, 1)$ is parameters measuring the degree of environmental persistence and defines how private investments convert into an improvement of the environmental quality index. In detail, pollution is proportional to output:

$$P_t = \gamma y_t \tag{4}$$

where $\gamma > 0$ denote the emissions intensity.

Therefore, the consumer can save on two types of assets: physical capital and an environmental worthless asset. Taking $\{w_t, R_{t+1}\}$ as given, the consumers’ problem is to choose an allocation $\{c_{y,t}, l_t, c_{o,t+1}, s_t, m_t\}$ so as to maximize his lifetime utility in (1) or (2), subject to the following budget constraints:

$$c_{y,t} + m_t + s_t = w_t l_t \tag{5}$$

$$c_{o,t+1} = s_t R_{t+1} \tag{6}$$

The Lagrangian function associated with this problem is the following:

$$\max_{\{c_{y,t}, l_t, c_{o,t+1}, s_t, m_t\}} \mathcal{L}_t = U_t(c_{y,t}, l_t, Q_t, c_{o,t+1}, Q_{t+1}) + \lambda_t(w_t l_t - c_{y,t} - m_t - s_t)$$

The first-order conditions for this maximization problem are the following:

$$\frac{\partial \mathcal{L}_t}{\partial c_{y,t}} = c_{y,t}^{-\sigma} - \lambda_t = 0 \tag{7}$$

$$\frac{\partial \mathcal{L}_t}{\partial c_{o,t+1}} = \beta c_{o,t+1}^{-\sigma} - \frac{\lambda_t}{R_{t+1}} = 0 \tag{8}$$

$$\frac{\partial \mathcal{L}_t}{\partial l_t} = w_t \lambda_t - B l_t^\psi = 0 \tag{9}$$

$$\frac{\partial \mathcal{L}_t}{\partial m_t} = \beta A Q_{t+1}^{\sigma_e} \phi - \lambda_t = 0 \tag{10}$$

Using these equations, we obtain:

$$c_{y,t} = \frac{c_{o,t+1}}{(\beta R_{t+1})^{\frac{1}{\sigma}}} = \left(\frac{B l_t^\psi}{w_t} \right)^{-\frac{1}{\sigma}} = (\beta A Q_{t+1}^{\sigma_e} \phi)^{-\frac{1}{\sigma}} \tag{11}$$

Manipulating Equations (11) and (5) we also obtain the following relationships:

$$c_{y,t} = \frac{w_t l_t}{1 + \beta^{\frac{1}{\sigma}} R_{t+1}^{\frac{1}{\sigma} - 1}} \tag{12}$$

$$s_t + m_t = \Gamma(R_{t+1}) w_t l_t, \quad \Gamma(R_{t+1}) = \frac{\beta^{\frac{1}{\sigma}} R_{t+1}^{\frac{1}{\sigma} - 1}}{1 + \beta^{\frac{1}{\sigma}} R_{t+1}^{\frac{1}{\sigma} - 1}} \tag{13}$$

An increase in R_{t+1} has two opposing effects on saving which are captured by the function $\Gamma(R_{t+1})$. First, the consumer will receive more interest income when he is old—this determining an income effect that encourages consumption when young and discouraging saving. Second, an increase in interest rate also lowers the relative price of future consumption. This creates an intertemporal substitution effect that discourages consumption when young and promotes saving. The strength of the two effects depends on the value of σ . In particular, the intertemporal substitution effect dominates when $\sigma < 1$, and $\sigma > 1$, the income effect dominates. The two effects exactly cancel out when $\sigma = 1$. Moreover, from Equation (11) we notice the importance of risk aversion parameters. In the case of $\sigma < \sigma_e$, agents are more sensitive to environmental risk than the risk regarding investments.

2.2. Firms

On the supply side of the economy, there is a large number of identical firms. In each period, each firm hires labor (l_t) and physical capital (k_t) from the competitive factor markets, and produces output according to:

$$y_t = A_t k_t^\alpha l_t^{1-\alpha} \tag{14}$$

From the profit maximization, we obtain the following first-order conditions (see Appendix A for further details.):

$$R_t = \alpha A_t k_t^{\alpha-1} l_t^{1-\alpha} \tag{15}$$

$$w_t = (1 - \alpha) A_t k_t^\alpha l_t^{-\alpha} \tag{16}$$

where A_t represents the total factor productivity (TFP). As in most dynamic stochastic general equilibrium (DSGE) models (e.g., [Kydland and Prescott 1982](#); [Smets and Wouters 2007](#); [Chang and Kim 2007](#)), TFP follows a first-order autoregressive process with an i.i.d.-normal error term (AR(1)):

$$\ln(A_t) = \rho \ln(A_{t-1}) + \epsilon_t \tag{17}$$

where $0 < \rho < 1$ is the shock persistence and ϵ_t is the error term with mean zero and standard deviation $\sigma_a > 0$.

2.3. Welfare Measures

To assess the implications on welfare, as in [Mendicino and Pescatori \(2007\)](#), the current welfare is measured by the discounted utility function of the young and old agents:

$$W_{y,t} = \mathbb{E}_t \sum_{t=0}^{\infty} \beta^t U_{y,t} \tag{18}$$

$$W_{o,t} = \mathbb{E}_t \sum_{t=0}^{\infty} \beta^t U_{o,t} \tag{19}$$

2.4. Competitive Equilibrium

The decentralized competitive equilibrium for a given process followed by technology the initial values for the capital stock, the environmental quality and pollution is a list of sequences $\{c_{y,t}, c_{o,t+1}, l_t, Q_t, m_t\}_{t=0}^{\infty}$ and prices $\{w_t, R_t\}_{t=0}^{\infty}$ such that the markets are clear, consumers maximize their utility function subject to their budget constraints, firms maximize the profit and the environmental quality follow their law of motion. From the competitive equilibrium, it is obtained the following law of motion:

$$(1 - n)k_t + 1 = s_t = (1 - \alpha) \left[\frac{\beta^{\frac{1}{\sigma}} R_{t+1}^{\frac{1}{\sigma} - 1}}{1 + \beta^{\frac{1}{\sigma}} R_{t+1}^{\frac{1}{\sigma} - 1}} \right] \left(\frac{k_t}{l_t} \right)^{-\alpha} l_t - m_t \tag{20}$$

If the investment in pollution reduction is positive, all other things being equal, the capital (savings) decrease. Adjusting the hours worked can enable sustainable development.

3. Calibration

This section presents model calibration between parameters drawn from typical macroeconomic literature and environmental parameters extracted from selected studies on emission and global temperature dynamics.

The economic parameters' values are calibrated for the US economy as in most overlapping generation models studies, and time is measured in quarters. Thus, the baseline values used for the rate of time preference—the depreciation rate of capital, the capital share in output, the inverse of Frisch elasticity, and the persistence parameter of the technology process—are the standards used in this literature (e.g., [Shi and Suen 2014](#)). Parameters A and B are calibrated endogenously, whereas parameters characterizing the environmental sector are in line with [John and Pecchenino \(1994\)](#), [Angelopoulos et al. \(2010; 2013\)](#), and [Annicchiarico and Di Dio \(2015\)](#). Table 1 lists the parameters used in the baseline model.

Following [Schechter \(2007\)](#), two calibrations for the risk aversion parameter are provided. First, this manuscript considers the case of σ equal to one. Second, to evaluate some effects related to the income effects, this study adopts $\sigma = 2$. Although these latter represent standard parametrization in OLG literature, this work provides an additional simulation to examine the implication for climate justice robustly. In this simulation, the risk aversion parameter is lower than one and is lower than the environmental risk aversion parameter.

Table 1. Model Calibration.

Parameter	Description	Value
β	Discount factor	0.99
δ	Depreciation rate capital	0.025
σ	Risk aversion parameter	1–2–0.75
σ_e	Risk aversion parameter environment	1–2
ψ	Inverse of Frisch elasticity	1
α	Share of capital	0.30
γ	Pollution intensity	0.38
δ_q	Degree of environmental persistence	0.90
ϕ	Environmental investment converter	1
\bar{Q}	Environmental quality without pollution	1
$\frac{\rho}{A}$	Persistence of the technology shock	0.90
A	Long-run total factor productivity	1

4. Steady-State

This section shows the stationary equilibrium of the economy with and without private investment in pollution abatement. First, it is characterized by the stationary equilibrium of an economy with zero environmental investment, i.e., $m = 0$ for all $t \geq 0$. A stationary equilibrium is a competitive equilibrium in which $k_t = k^*$, $l_t = l^*$ and $R_t = R^*$ for all $t \geq 0$. Substituting these conditions into Equation (20) gives:

$$\left[\frac{\beta^{\frac{1}{\sigma}} R^{*\frac{1}{\sigma}-1}}{1 + \beta^{\frac{1}{\sigma}} R^{*\frac{1}{\sigma}-1}} \right] \left(\frac{k^*}{l^*} \right)^{-\alpha} = \frac{1 + n}{1 - \alpha} \tag{21}$$

Manipulating Equation (21) we obtain:

$$\Theta(R^*) = \left[\frac{\beta^{\frac{1}{\sigma}} R^{*\frac{1}{\sigma}}}{1 + \beta^{\frac{1}{\sigma}} R^{*\frac{1}{\sigma}-1}} \right] = \frac{\alpha(1 + n)}{1 - \alpha} \tag{22}$$

Equation (20) follows from the fact that $R_t = \alpha \left(\frac{k^*}{l^*} \right)^{\alpha-1}$. For $\sigma > 0$, $\Theta(R^*)$ is strictly increasing with: $\lim_{R^* \rightarrow 0} \Theta(R^*) = 0$ and $\lim_{R^* \rightarrow \infty} \Theta(R^*) = \infty$. Hence exists a unique $R^* > 0$ that solves Equation (21). The steady-state value of all other variables can be uniquely determined by:

$$w^* = (1 - \alpha) \left(\frac{\alpha}{R^*} \right)^{\frac{\alpha}{1-\alpha}} \tag{23}$$

$$l^* = B^{-\frac{1}{\alpha+\psi}} \left[\left(1 + \beta^{\frac{1}{\sigma}} (R^*)^{\frac{1}{\sigma}-1} \right) \right]^{\frac{\sigma}{\sigma+\psi}} (w^*)^{\frac{1-\sigma}{\sigma+\psi}} \tag{24}$$

$$k^* = l^* \left(\frac{\alpha}{R^*} \right)^{\frac{1}{1-\alpha}} \tag{25}$$

$$y^* = (k^*)^\alpha (l^*)^{1-\alpha} \tag{26}$$

$$c_y^* = \frac{c_o^*}{(\beta R^*)^{\frac{1}{\sigma}}} \tag{27}$$

$$P^* = \gamma y^* \tag{28}$$

$$Q^* = \bar{Q} - \frac{P^*}{(1 - \delta_q)} \tag{29}$$

Conversely, in the case of environmental investment, the stationary equilibrium starts from the following steady-state condition:

$$m^* + (1 - n)k^* + 1 = m^* + s^* = (1 - \alpha) \left[\frac{\beta^{\frac{1}{\sigma}} R^{*\frac{1}{\sigma}}}{1 + \beta^{\frac{1}{\sigma}} R^{*\frac{1}{\sigma} - 1}} \right] \left(\frac{k^*}{l^*} \right)^{-\alpha} \quad (30)$$

Then substituting R^* into Equations (23)–(27) yields a unique set of steady-state values for the scenario in which consumers use part of their pollution abatement resources.

In order to determine the steady-state values, the necessity of a specific numerical example arose. The software Dynare was employed to obtain a solution for the equilibrium employing a nonlinear Newton-type solver.¹ Table 2 reports the deterministic steady-state for variables chosen to understand the climate justice behavior in accord with the discussed calibration and considering different value for the risk aversion parameter σ . In detail, the proxies detected are (i) output for the economic growth; (ii) environmental quality to define the status of the environment; (iii) labor and environmental investment to determine the level of society; (iv) welfare from young and old to detect the intergenerational inequalities. The other variables are useful to understand the mechanisms inside the depicted model economy.

Table 2. Numerical example—steady-state.

Variables	OLG	OLG-Q	OLG-Q	OLG-Q
	$\sigma = 1$	$\sigma = 1$	$\sigma = 2$	$\sigma = 0.7$
Interest Rate	1.492	1.915	2.352	1.661
Output	0.166	0.191	0.170	0.192
Capital-Saves	0.034	0.030	0.022	0.034
Labor	0.331	0.424	0.422	0.401
Abatement Spending	0.000	0.029	0.027	0.023
Environmental Quality	0.000	0.033	0.033	0.027
Pollution	0.017	0.019	0.017	0.019
Welfare-Young	−4.631	−7.633	−64.524	1.164
Welfare-Old	−2.521	−4.743	−21.613	2.083

The first column shows the value in the standard Diamond OLG model. In this case, $m = 0$, and the environmental quality index is equal to zero. In this context, climate justice does not hold, seeing as how the agents maximize their welfare, ignoring the impact on the environment of their actions. In contrast, in the case of $m > 0$, young generations employ parts of their resources to invest in improving environmental quality. In the model described in this work, a sustainable development hypothesis holds if R and labor are higher than the case without environmental investment. When σ is equal to 1, both the environmental quality index and pollution increase, but this is obtained through increased labor from the young. Hence, improving environmental quality has a more significant impact on young people. The impact becomes even more important if $\sigma = 2$. Thus, there is a reduction in intragenerational justice. By contrast, in a low-risk aversion scenario, an environmental and socially sustainable development profile can be reached. A high level of output can be achieved by improving the environmental quality and reducing the generation inequalities. In this context, the environmental risk aversion prevails over economic risk aversion ($\sigma < \sigma_e$). These characteristics allow agents to make beneficial choices for the environment with less effort from the younger generations.

5. Impulse Response Analysis

This section provides the impulse response analysis of a technology shock. In detail, in order to verify the impact of the shock on the climate justice variables, we provide a comparison of our model with the classical Diamond model in the case of $\sigma = 1$. Figure 1 shows the impulse response functions after a positive productivity shock of

¹ We use Dynare software (available on <https://www.dynare.org/>, accessed on 1 August 2019) and function `Fsolve` under MATLAB to determine the steady-state values (for further details see Adjemian et al. 2011).

1%. This simulation allows understanding climate justice related to the business cycle fluctuations in two scenarios: environmentally “indifferent” and “aware” consumers. The simulations were obtained using numerical analysis and perturbation methods to simulate the economy and compute the equilibrium conditions outside the steady-state. We solved the model using a second-order Taylor approximation around its steady-state (see (Judd 1998) and (Schmitt-Grohe and Uribe 2004)).

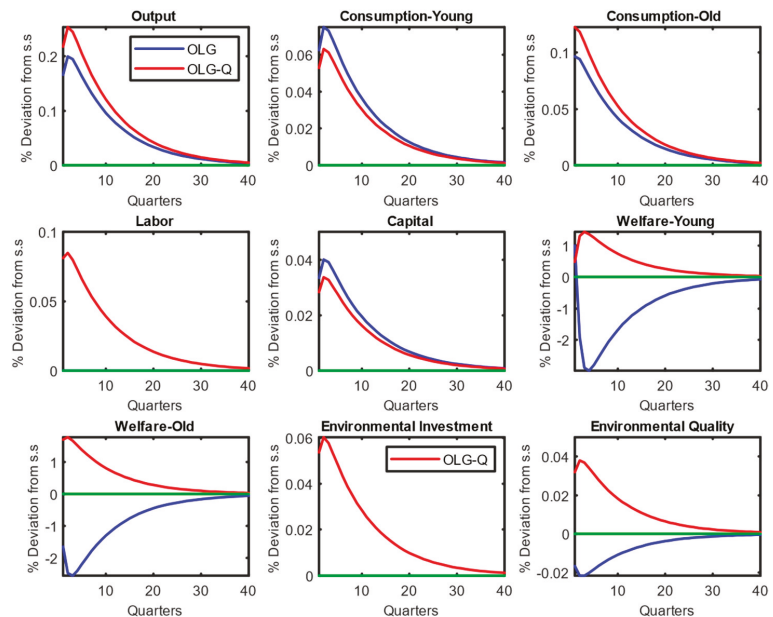

Figure 1. Impulse response to a technology shock (1%).

All results are reported as percentage deviations from the steady-state. As shown in Figure 1, the productivity shock determines the growth of the output in both cases. The model with environmental investments allows reaching a greater output peak, triggered by a rise in labor from the young generation. Instead, the hours worked do not undergo a significant change in the classical model, and the environmental investments are equal to zero. Both young and old consumption increase after a technology shock. The young generations perform less increase in the Diamond model augmented with environmental investment since they use a part of their income to improve environmental quality. By contrast, the old generation can consume a greater quantity if the younger generations invest in improving environmental quality. The standard OLG model does not allow sustainable development. However, the OLG model with environmental investments allows for sustainable development and improvement of environmental quality. The commitment of young people to reduce pollution allows the growth of the well-being of both generations.

6. Conclusions and Policy Implications

The stylized facts synthesized draw a world where economic growth needs and prosperity for all have to be coupled with sustainability for the main international community goals. The limits to growth were already flagged in 1972 from the Club of Rome (Meadows et al. 1972), where it was expressed the necessity to foster a long-term, inter-generational, and inclusive development. In this regard, the complex phenomena tackled by sustainable development started requiring a multidimensional approach, that was faced through a number of methodologies, solvable thanks to diverse composite indicator

techniques inter alia (Nardo et al. 2005; Drago and Gatto 2018). Climate justice relies on practical bottom-up and pushed-down actions fostering the vulnerable empowerment. Major support is being reached by expanding sectors and development programs such as microfinance. Through a set of instruments, as microloans to jumpstart or consolidate micro-entrepreneurship, remittances from workers abroad, microinsurance against shocks, and saving schemes, these programs aim to work for women, youth, rural people, and vulnerable categories empowerment, ensuring climate resilience policies above all connecting them with energy, food and water security, resilience, and justice (Gatto and Busato 2020). These features are recently becoming of great effectiveness whether connected with energy, agriculture, water and resources, passing by entrepreneurship boosting (Gatto and Drago 2021). An example is the implementation of microfinance programs for energy entrepreneurship in sub-Saharan Africa. The understanding of the possible generation interplays will have foremost importance in preserving good environmental quality. Attributing a sound role to policy and politics in nudging the socioeconomic and ecological concerns will be decisive for addressing upcoming directions of climate justice and is multilayered and polycentric. Foreseeable actions rely on international, domestic and local governance that will be able to shape the future of human, ecosystems and planetary health (Panarello 2021; Punzo et al. 2019; Held and Roger 2018; Ostrom 2012). Crucial measures will have to be detected from environmental responsibility and behaviors, international environmental agreements and protocols, and energy and resource transition (Sadik-Zada and Gatto 2020; 2021).

In this paper, it was shown that when $R(m) > R$, labor supply is elastic and consumers are less risk-averse, and possibly reaches a stationary state in which climate justice holds. Besides, this study shows that the business-as-usual climate justice is currently achievable only with an increase in young effort and with a reduction in their leisure and consumption—that is a sustainability paradox. Achieving an improved balance is linked to consumer culture: they want a smoothed consumption prole over time, reducing its variability. The households' risk aversion makes it harder to achieve the desirable stationary equilibrium. The model displays potential for further implementations. One direction for future research is to extend these results to a Ramsey Model in order to analyze the optimal taxation. Another possibility is to extend the model to allow an intergenerational analysis considering several cohorts. Further developments to this exercise would include making use of alternative baseline economies—other than the US yardstick calibration. Other papers could consider policy effects as carbon taxes or caps on trade as sensitivity analysis or alternative models and scenarios.

Author Contributions: All authors contributed equally to the work. All authors have read and agreed to the published version of the manuscript.

Funding: This research received no external funding.

Acknowledgments: The authors shall acknowledge Reyer Gerlagh for his insightful comments. The authors are also grateful to Demetrio Panarello, Maria Carratù and all participants of the 4th Conference on “Econometric Models of Climate Change” at the University of Milan-Bicocca (Milan, Italy) on 29–30 August 2019, Center for European Studies (CefES) and the Department of Economics, Management and Statistics (DEMS) at the University of Milan-Bicocca, CREATES at Aarhus University, Department of Economics and Finance (DEF) at the University of Rome-Tor Vergata, Climate Econometrics at the University of Oxford and the Department of Economics at the University of Victoria.

Conflicts of Interest: The authors declare no conflict of interest.

Appendix A

In a decentralized economy, the households' objective is to maximize the lifetime welfare by choosing the levels of consumptions $(c_{y,t}, c_{o,t+1})$, environmental expenditure (m_t) , labor (l_t) , and save (s_t) , under constraints of resources, pollution and the environmental quality:

$$\begin{aligned} & \max_{\{c_{y,t}, l_t, c_{o,t+1}, s_t, m_t\}} U_t(c_{y,t}, l_t, Q_t, c_{o,t+1}, Q_{t+1}) \\ \text{s.t. : } & \begin{cases} Q_{t+1} = (1 - \delta_q)\bar{Q} + \delta_q Q_t - P_t + \phi m_t \\ c_{y,t} + m_t + s_t = w_t l_t \\ c_{o,t+1} = s_t R_{t+1} \end{cases} \end{aligned}$$

The Lagrangian associated with this problem is the following:

$$\max_{\{c_{y,t}, l_t, c_{o,t+1}, s_t, m_t\}} \mathcal{L}_t = U_t(c_{y,t}, l_t, Q_t, c_{o,t+1}, Q_{t+1}) + \lambda_t(w_t l_t - c_{y,t} - m_t - s_t)$$

where:

$$s_t = \frac{c_{o,t+1}}{R_{t+1}}$$

and:

$$Q_{t+1} = (1 - \delta_q)\bar{Q} + \delta_q Q_t - P_t + \phi m_t$$

The first-order conditions for this maximization problem are the following:

$$\begin{aligned} \frac{\partial \mathcal{L}_t}{\partial c_{y,t}} &= c_{y,t}^{-\sigma} - \lambda_t = 0 \\ \frac{\partial \mathcal{L}_t}{\partial c_{o,t+1}} &= \beta c_{o,t+1}^{-\sigma} - \frac{\lambda_t}{R_{t+1}} = 0 \\ \frac{\partial \mathcal{L}_t}{\partial l_t} &= w_t \lambda_t - B l_t^\psi = 0 \\ \frac{\partial \mathcal{L}_t}{\partial m_t} &= \beta A Q_{t+1}^{\sigma_e} \phi - \lambda_t = 0 \end{aligned}$$

The representative firm goal is to maximize its profits under the technology constraint:

$$\begin{aligned} \max_{l_t, k_t} \Pi_t &= y_t - w_t l_t - R_t k_t \\ \text{s.t.} & \\ y_t &= A_t k_t^\alpha l_t^{1-\alpha} \end{aligned}$$

The first-order conditions for this maximization problem are the following:

$$\begin{aligned} \frac{\partial \Pi_t}{\partial k_t} &= \alpha A_t k_t^{\alpha-1} l_t^{1-\alpha} - R_t = 0 \\ \frac{\partial \Pi_t}{\partial l_t} &= (1 - \alpha) A_t k_t^\alpha l_t^{-\alpha} - w_t = 0 \end{aligned}$$

References

- Adjemian, Stephane, Houtan Bastani, Michel Juillard, Frederic Karame, Junior Maih, Ferhat Mihoubi, Willi Mutschler, George Perendia, Johannes Pfeifer, Marco Ratto, and et al. 2011. *Dynare: Reference Manual*. Paris: Cepremap, version 4.
- Agovino, Massimiliano, Massimiliano Cerciello, and Andrea Gatto. 2018. Policy efficiency in the field of food sustainability. The ad-justed food agriculture and nutrition index. *Journal of Environmental Management* 218: 220–233. [[CrossRef](#)] [[PubMed](#)]
- Angelopoulos, Konstantinos, George Economides, and Apostolis Philippopoulos. 2010. *What Is the Best Environmental Policy? Taxes, Permits and Rules under Economic and Environmental Uncertainty*. Working Papers 119. Athens: Bank of Greece.

- Angelopoulos, Konstantinos, George Economides, and Apostolis Philippopoulos. 2013. First-and second-best allocations under economic and environmental uncertainty. *International Tax and Public Finance* 20: 360–80. [CrossRef]
- Annicchiarico, Barbara, and Fabio Di Dio. 2015. Environmental policy and macroeconomic dynamics in a new Keynesian model. *Journal of Environmental Economics and Management* 69: 1–21. [CrossRef]
- Bayer, Stefan, and Dieter Cansier. 1996. *Systematic Discounting in Climate Policy Analysis (No. 85)*. Tübinger Diskussionsbeiträge: University of Tuebingen.
- Bickerstaff, Karen, Gordon Walker, and Harriet Bulkeley, eds. 2013. *Energy Justice in a Changing Climate: Social Equity and Low-Carbon Energy*. London: Zed Books Ltd.
- Brando, Nicolas, Christiaan Boonen, Samuel Cogolati, Rutger Hagen, Nils Vanstappen, and Jan Wouters. 2019. Governing as commons or as global public goods: Two tales of power. *International Journal of the Commons* 13: 1. [CrossRef]
- Brenkert, Antoinette L., and Elizabeth L. Malone. 2005. Modeling vulnerability and resilience to climate change: A case study of India and Indian states. *Climatic Change* 72: 57102. [CrossRef]
- Campbell, Bruce M., James Hansen, Janie Rioux, Clare M. Stirling, and Stephen Twomlow. 2018. Urgent action to combat climate change and its impacts (SDG 13): Transforming agriculture and food systems. *Current Opinion in Environmental Sustainability* 34: 13–20. [CrossRef]
- Chang, Yongsung, and Sun B. Kim. 2007. Heterogeneity and aggregation: Implications for labor-market fluctuations. *American Economic Review* 97: 1939–56. [CrossRef]
- Diamond, Peter. A. 1965. National debt in a neoclassical growth model. *The American Economic Review* 55: 1126–50.
- Drago, Carlo, and Andrea Gatto. 2018. A robust approach to composite indicators exploiting interval data: The interval-valued global gender gap index (IGGGI). In *IPAZIA Workshop on Gender Issues*. Cham: Springer, pp. 103–14.
- Francis, Pope. 2015. On Care for Our Common Home: Laudato si. Available online: <https://www.usccb.org/issues-and-action/human-life-and-dignity/environment/upload/laudato-si-discussion-guide.pdf> (accessed on 31 March 2021).
- Gatto, Andrea. 2020. A pluralistic approach to economic and business sustainability: A critical meta-synthesis of foundations, metrics, and evidence of human and local development. *Corporate Social Responsibility and Environmental Management* 27: 1525–39. [CrossRef]
- Gatto, Andrea, and Carlo Drago. 2020a. A taxonomy of energy resilience. *Energy Policy* 136: 111007. [CrossRef]
- Gatto, Andrea, and Carlo Drago. 2020b. Measuring and modeling energy resilience. *Ecological Economics* 172: 106527. [CrossRef]
- Gatto, Andrea, and Carlo Drago. 2021. When renewable energy, empowerment, and entrepreneurship connect: Measuring energy policy effectiveness in 230 countries. *Energy Research & Social Science*. forthcoming.
- Gatto, Andrea, and Francesco Busato. 2020. Energy vulnerability around the world: The global energy vulnerability index (GEVI). *Journal of Cleaner Production* 253: 118691. [CrossRef]
- Gatto, Andrea, Norman Polselli, and Gretchen Bloom. 2016. Empowering gender equality through rural development: Rural markets and micro-finance in Kyrgyzstan. In *L'Europa e la Comunità Internazionale Di fronte alle Sfide dello Sviluppo*. Available online: https://www.researchgate.net/publication/323153820_Empowering_Gender_Equality_through_Rural_Development_Rural_Markets_and_Micro-Finance_in_Kyrgyzstan (accessed on 31 March 2021).
- Gerlagh, Reyer, and Michiel A. Keyzer. 2001. Sustainability and the intergenerational distribution of natural resource entitlements. *Journal of Public Economics* 79: 315–41. [CrossRef]
- Grasso, Marco. 2004. *Climate Change: The Global Public Good*. Working Paper Series No. 75. Milano: Department of Economics, Bicocca University of Milan.
- Held, David, and Charles Roger. 2018. Three models of global climate governance: From Kyoto to Paris and beyond. *Global Policy* 9: 527–37. [CrossRef]
- Howarth, Richard. B. 1998. An overlapping generations model of climate-economy interactions. *Scandinavian Journal of Economics* 100: 575–91. [CrossRef]
- Introcasa, David. 2018. Climate Change Is the Greatest Threat to Human Health in History Health Affairs. Available online: <https://www.healthaffairs.org/doi/10.1377/hblog20181218.278288/full/> (accessed on 31 March 2021).
- IPCC. 2018. *Global Warming of 1.5 C. An IPCC Special Report on the Impacts of Global Warming of 1.5 C above Pre-Industrial Levels and Related Global Greenhouse Gas Emission Pathways, in the Context of Strengthening the Global Response to the Threat of Climate Change, Sustainable Development, and Efforts to Eradicate Poverty*. Edited by Valerie Masson-Delmotte, Panmao Zhai, Hans O. Portner, Debra Roberts, James Skea, Priyadarshi R. Shukla, Anna Pira-ni, Wilfran Moufouma-Okia, C. Pean, Roz Pidcock and et al. Geneva: World Meteorological Organization.
- Jenkins, Kirsten. 2018. Setting energy justice apart from the crowd: Lessons from environmental and climate justice. *Energy Research & Social Science* 39: 117–21.
- John, Andrew, and Rowena Pecchenino. 1994. An overlapping generations model of growth and the environment. *The Economic Journal* 104: 1393–410. [CrossRef]
- Judd, Kenneth L. 1998. *Numerical Methods in Economics*. Cambridge: MIT Press.
- Kaul, Inge, Pedro Conceicao, Katell L. Goulven, and Ronald U. Mendoza. 2003. *Providing Global Public Goods: Managing Globalization*. New York: Oxford University Press.
- Kelleher, David. 2000. *Global Public Goods: International Cooperation in the 21st Century*. New York: Oxford University Press.

- Koca, Deniz, Benjamin Smith, and Martin T. Sykes. 2006. Modelling regional climate change effects on potential natural ecosystems in Sweden. *Climatic Change* 78: 381–406. [\[CrossRef\]](#)
- Kydland, Finn. E., and Edward C. Prescott. 1982. Time to build and aggregate fluctuations. *Econometrica: Journal of the Econometric Society* 50: 1345–370. [\[CrossRef\]](#)
- Martens, Pim. 2013. *Health and Climate Change: Modelling the Impacts of Global Warming and Ozone Depletion*. London: Routledge.
- McKinnon, Catriona. 2015. Climate justice in a carbon budget. *Climatic Change* 133: 375–84. [\[CrossRef\]](#)
- Meadows, Donella. H., Dennis L. Meadows, Jorgen Randers, and William W. Behrens. 1972. *The Limits to Growth*. New York: Universe Books.
- Mendicino, Caterina, and Andrea Pescatori. 2007. Credit Frictions, Housing Prices and Optimal Monetary Policy Rules. Available online: <http://repec.org/mmfc05/paper67.pdf> (accessed on 31 March 2021).
- Nardo, Michela, Michaela Saisana, Andrea Saltelli, and Stefano Tarantola. 2005. Tools for composite indicators building. *European Commission* 15: 19–20.
- Nordhaus, William D. 1994. *Managing the Global Commons: The Economics of Climate Change*. Cambridge: MIT Press.
- Nordhaus, William D. 2006. Paul Samuelson and global public goods. In *Samuelsonian Economics and the Twenty-First Century*. Oxford: Oxford University Press.
- Ostrom, Elinor. 2010. Beyond Markets and States: Polycentric Governance of Complex Economic Systems. *American Economic Review* 100: 641–72. [\[CrossRef\]](#)
- Ostrom, Elinor. 2012. Nested Externalities and Polycentric Institutions: Must We Wait for Global Solutions to Climate Change Before Taking Actions at Other Scales? *Economic Theory* 49: 353–69. [\[CrossRef\]](#)
- Ostrom, Elinor. 2015. *Governing the Commons*. Cambridge: Cambridge University Press.
- Panarello, Demetrio. 2021. Economic insecurity, conservatism, and the crisis of environmentalism: 30 years of evidence. *Socio-Economic Planning Sciences* 73: 100925. [\[CrossRef\]](#)
- Picot, Helen, and Nicholas Moss. 2014. The Sustainable Development Goals: Will They Deliver Climate Compatible Development for Vulnerable Countries? Available online: https://cdkn.org/resource/working-paper-the-sustainable-development-goals-will-they-deliver-climate-compatible-development-for-vulnerable-countries/?loclang=en_gb (accessed on 31 March 2021).
- Punzo, Gennaro, Demetrio Panarello, Margherita M. Pagliuca, Rosalia Castellano, and Maria C. Aprile. 2019. Assessing the role of perceived values and felt responsibility on pro-environmental behaviours: A comparison across four EU countries. *Environmental Science & Policy* 101: 311–22.
- Rhodes, Christopher J. 2016. The 2015 Paris climate change conference: COP21. *Science Progress* 99: 97–104. [\[CrossRef\]](#)
- Roser, Dominic, Christian Huggel, Markus Ohndorf, and Ivo Wallimann-Helmer. 2015. Advancing the interdisciplinary dialogue on climate justice. *Climatic Change* 133: 349–59. [\[CrossRef\]](#)
- Rutter, Otto. 2019. Power to the children. *The Lancet Planetary Health* 3: e102.
- Sachs, Jeffrey D. 2014. Climate change and intergenerational well-being. In *The Oxford Handbook of the Macroeconomics of Global Warming*. New York: Oxford University Press, pp. 248–59.
- Sadik-Zada, Elkhani R., and Andrea Gatto. 2020. The puzzle of greenhouse gas footprints of oil abundance. *Socio-Economic Planning Sciences*. [\[CrossRef\]](#)
- Sadik-Zada, Elkhani R., and Andrea Gatto. 2021. Energy security pathways in South East Europe: Diversification of the natural gas supplies, energy transition, and energy futures. In *From Economic to Energy Transition*. Cham: Palgrave Macmillan, pp. 491–514.
- Schechter, Laura. 2007. Risk aversion and expected-utility theory: A calibration exercise. *Journal of Risk and Uncertainty* 35: 67–76. [\[CrossRef\]](#)
- Schmitt-Grohe, Stephanie, and Martin Uribe. 2004. Solving Dynamic General Equilibrium Models. Using a Second-Order Approximation to the Policy Function. *Journal of Economic Dynamics and Control* 28: 755–75. [\[CrossRef\]](#)
- Schneider, Maik. T., Christian P. Traeger, and Ralph Winkler. 2012. Trading off generations: Equity, discounting, and climate change. *European Economic Review* 56: 1621–44. [\[CrossRef\]](#)
- Sen, Zekai. 2008. *Solar Energy Fundamentals and Modeling Techniques: Atmosphere, Environment, Climate Change and Renewable Energy*. London: Springer. Science & Business Media, p. 276.
- Shaffer, Gregory. 2012. International law and global public goods in a legal pluralist world. *European Journal of International Law* 23: 669–93. [\[CrossRef\]](#)
- Shi, Lisi, and Richard. M. Suen. 2014. Asset bubbles in an overlapping generations model with endogenous labor supply. *Economics Letters* 123: 164–67. [\[CrossRef\]](#)
- Shue, Henry. 2014. *Climate Justice: Vulnerability and Protection*. New York: Oxford University Press.
- Smets, Frank, and Rafael Wouters. 2007. Shocks and frictions in US business cycles: A Bayesian DSGE approach. *American Economic Review* 97: 586–606. [\[CrossRef\]](#)
- Sovacool, Benjamin. K. 2013. Adaptation: The complexity of climate justice. *Nature Climate Change* 3: 959. [\[CrossRef\]](#)
- Stephan, Gunter, Georg Müller-Fürstenberger, and Pascal Previdoli. 1997. Overlapping generations or infinitely-lived agents: Intergenerational altruism and the economics of global warming. *Environmental and Resource Economics* 10: 27–40. [\[CrossRef\]](#)
- Stern, Nicholas, and Chris Taylor. 2007. Climate change: Risk, Ethics, and the Stern review. *Science* 317: 203–04. [\[CrossRef\]](#)
- UNESCO. 2014. *Ethical Principles for Climate Change: Adaptation and Mitigation Report of COMEST*. Oxford: John Wiley & Sons Ltd. [\[CrossRef\]](#)

- United Nations (UN). 2015. *Transforming our World: The 2030 Agenda for Sustainable Development*. New York: Division for Sustainable Development Goals.
- Weitzman, Martin L. 2009. On modeling and interpreting the economics of catastrophic climate change. *The Review of Economics and Statistics* 91: 1–19. [[CrossRef](#)]
- Xu, Chong Y. 2000. Modelling the effects of climate change on water resources in central Sweden. *Water Resources Management* 14: 177–89. [[CrossRef](#)]

Review

Trade–Climate Nexus: A Systematic Review of the Literature

Jeremiás Máté Balogh* and Tamás Mizik

Department of Agribusiness, Corvinus University of Budapest, 1093 Budapest, Hungary; tamas.mizik@uni-corvinus.hu

* Correspondence: jeremias.balogh@uni-corvinus.hu

Abstract: In the climate–trade debate, moderate attention is dedicated to the role of trade agreements on climate. In turn, trade agreements could help countries meet climate goals by removing tariffs, harmonizing standards on environmental goods, and eliminating distorting subsidies on fossil fuels. This paper aims to provide an overview of the role of trade agreements on climate-change mitigation. This systematic literature review is based on the international economic literature published between 2010 and 2020. This literature review underlines that the effectiveness of the trade agreements and WTO negotiations on emission reduction is weak. This is due to different national interests and protectionism. The elimination of trade barriers stimulates trade, but this may also raise greenhouse gas emissions and cause other environmental problems (e.g., deforestation). Furthermore, this article points out that emission leakage is also a crucial issue hindering the success of global climate agreements on greenhouse gas reduction. The greatest beneficiaries of the trade agreements are usually the largest GHG emitters, such as China, the US, and the EU. By contrast, developing countries are in a weaker position regarding climate–trade negotiation. The literature review offers policy solutions which can contribute to emission reduction and tools for stimulating a trade-related climate-change abatement policy.

Keywords: trade agreements; WTO; climate change; carbon dioxide emission; literature review

Citation: Balogh, Jeremiás Máté, and Tamás Mizik. 2021. Trade–Climate Nexus: A Systematic Review of the Literature. *Economics* 9: 99. <https://doi.org/10.3390/economics9030099>

Academic Editor: George Halkos

Received: 16 May 2021

Accepted: 25 June 2021

Published: 29 June 2021

Publisher’s Note: MDPI stays neutral with regard to jurisdictional claims in published maps and institutional affiliations.



Copyright: © 2021 by the authors. Licensee MDPI, Basel, Switzerland. This article is an open access article distributed under the terms and conditions of the Creative Commons Attribution (CC BY) license (<https://creativecommons.org/licenses/by/4.0/>).

1. Introduction

Global warming and climate change will undoubtedly determine the present century, and they are frequently on the agenda of different international negotiations. The Intergovernmental Panel on Climate Change (IPCC) stressed the consequences of climate change caused by anthropogenic factors. According to the possible scenarios, the growth of the greenhouse gas (GHG) concentration in the atmosphere is expected to double by 2030, indicating an average temperature increase of 1.5–4.5 degrees (IPCC 2019). This changes the Earth’s climate radically.

In line with the expansion of the world economy and the increasing environmental pollution, several international environmental agreements have been signed (Stockholm Declaration, Montréal Protocol, Kyoto Protocol, Paris Agreement, etc.). After the ratification of the Paris Agreement in 2015, certain small countries managed to cut back their carbon dioxide (CO₂) emissions successfully; however, most of the countries’ climate policies show a lack of ambition (e.g., Russia, China, the USA, South Africa, Indonesia, and Japan). Consequently, the world probably remains on the track of temperature increases of more than 3 °C (Climate Action Tracker 2020). This path does not seem to be changing significantly, despite a slight decline in CO₂ emission induced by the COVID-19 pandemic (United Nations Environment Programme 2020).

Rising global average incomes have increased consumer demand for traded goods. Most countries are net importers of carbon emissions; therefore, their consumption-based emissions are higher than their territory-based emissions. In the past decades, the gap between consumption and production-based emissions¹ has been growing in high-income

countries, such as the US, the EU-27, the UK, Japan, and China ([United Nations Environment Programme 2020](#)). Moreover, China is responsible for half of the global carbon outflows through trade ([Liddle 2017](#)).

In the climate–trade debate, relatively limited attention is paid to trade agreements and climate change nexus. However, trade agreements can help to achieve climate mitigation goals by removing tariffs, harmonizing standards on environmental goods, and eliminating distorting subsidies on fossil fuels, as well as on the agricultural sector ([Griffin et al. 2019](#)). Despite the trade–climate synergies, reductions of the average tariff levels have increased trade in carbon-intensive and environmentally damaging products, such as fossil fuels and timber, more than it has for environmentally friendly products ([Griffin et al. 2019](#)).

Moreover, trade acceleration and liberalization may facilitate pollution-intensive activities, carbon emissions from fossil fuel combustion embodied in trade, degradation of natural resources and production growth ([Balogh and Jámbor 2020](#)). Deforestation can also be a result of trade ([Heyl et al. 2021](#)). Association of Southeast Asian Nations (ASEAN) countries are growing at the expense of their environment and giving way to emission-intensive trade ([Solomon and Khan 2020](#)).

In the 1970s, the connection between trade and environmental protection was recognized. During the Uruguay Round’s trade negotiation (1986–1994), significant attention was paid to trade-related environmental issues. From 1948 to 1994, the General Agreement on Tariffs and Trade (GATT) facilitated world trade. In 1994, due to the Uruguay Round and the Marrakesh Declaration, the World Trade Organization (WTO) was established. The WTO incorporates GATT principles and provides an enduring institutional system for implementing and extending them. GATT Article XX on General Exceptions covers specific instances in which WTO members may be exempt from GATT rules. Paragraphs (b) and (g) of GATT Article XX are connected with the protection of the environment. According to these paragraphs, WTO members cannot adopt policy measures inconsistent with GATT regulations, except to protect human, animal or plant life/health or linking them to the conservation of exhaustible natural resources. Under WTO rules, members can adopt trade-related measures aiming to protect the environment, ensure sustainable development, and avoid protectionism ([WTO 2020](#)).

Climate policies often indicate conflicts that trade agreements try to reconcile. Nevertheless, trade agreements signed over the last decades have included more clauses relating to climate goals, initiating a more supportive relationship between trade and climate change ([Griffin et al. 2019](#)). These facts emphasize the importance of trade–environment-related issues in environment protection and GHG reduction.

Most review papers have analyzed the effects of the free trade agreements on climate change ([Low and Murina 2010](#); [Ackrill and Kay 2011](#); [Meyer 2017](#); [Morin and Jinnah 2018](#); [Heyl et al. 2021](#)). On the contrary, a limited number of review articles have addressed the influences of international trade on climate change ([Friel et al. 2020](#); [Balogh and Jámbor 2020](#)), focusing on trade agreements, compared to empirical papers. This study aims to complement the existing literature by exploring these effects.

This paper addresses the research question of how international trade agreements affect climate change and whether they conflict with climate policy and contribute to decreasing or increasing GHG emissions. More specifically, this article applies a systematic literature review to explore the recent empirical findings on the role of international trade agreements, negotiations, and relations in climate policy and mitigation.

The contribution of the research to the existing literature is manifold. First, this overviews the recent empirical research investigating the impacts of the different trade agreements and WTO rules in climate change mitigation policies. This reflects the main climate-related concern linked to various trade agreements at the regional, multilateral, and bilateral level. It provides policy recommendations on how to tackle trade agreements’ weaknesses in international climate and trade policy. The interrelation of climate and trade policy (under WTO), various trade agreements (RTA, NAFTA, and PTA), and their mitigation effects are also discussed.

The paper is structured as follows. The following section presents the Materials and Methods applied. Section 3 discusses the results by addressing problems and solutions offered by the literature review, while the final section provides conclusions.

2. Materials and Methods

The online databases of Web of Science (WoS), Scopus, and Google Scholar searched to answer the research question on the impact of trade agreements on climate change. The process of the systematic literature review was realized on 21 September 2020. The selection of relevant studies is based on the method of Moher et al. (2009).

The combination of keywords “trade agreement” and “climate change” (Scopus 2020; Web of Science 2020; Google Scholar 2020) were used, and they had to appear in the title, abstract or keywords of the studies. The search was limited to Web of Science categories such as environmental studies or agriculture multidisciplinary or economics or agricultural economics policy. In the Scopus search engine, the command TITLE-ABS-KEY (“trade agreement” AND “climate change”) AND LIMIT-TO (SUBJAREA, “ECON”) were used, limited the search to economics discipline.

Only English materials were selected (LIMIT-TO (LANGUAGE, “English”) and the search was limited to scientific journal articles (article or review), while book chapters or books were excluded from the dataset. The analyses restricted to the international economic literature published between 2000 and 2020.

The initial search (Scopus, WoS, and Google Scholar) resulted in 290 entries, out of which 12 were duplicates (appeared in WoS and Scopus as well), of 9 were books, book chapters and reports (retrieved from Google Scholar). These 21 articles (9 + 12) were excluded. Figure 1 provides an overview of the selection process.

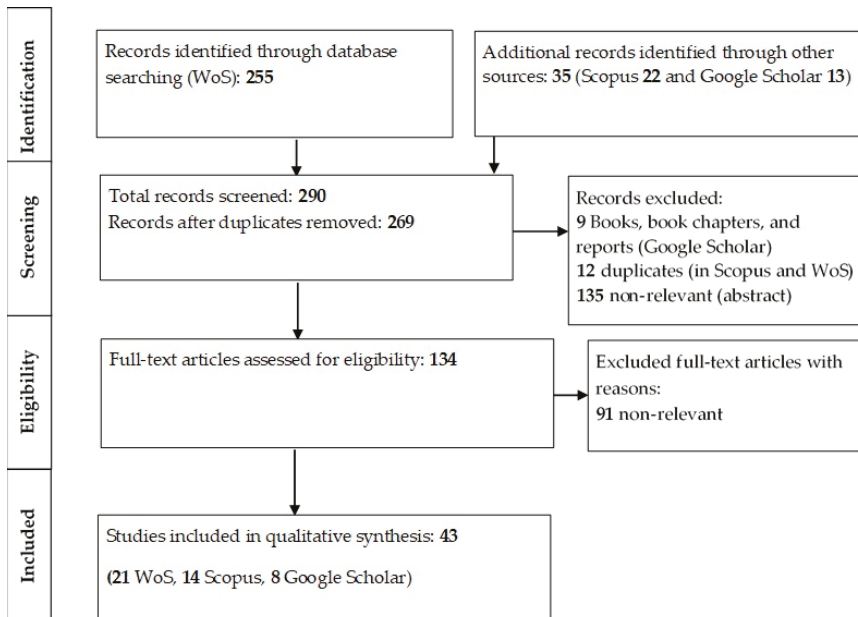

Figure 1. The steps of the literature selection process. Note: the time period of the search was restricted to the period of 2010–2020, and only journal articles and reviews were selected. Source: Authors’ composition based on Moher et al. (2009).

After the first screening, WoS and Scopus search resulted in 255 and 22 records, respectively. To ensure that only relevant articles are included in the final analysis, the abstracts were read and evaluated based on the selected keywords. The abstract screening produced

135 (of 269) non-relevant studies. In the case of non-relevant studies, keywords were not included in their abstracts). The full texts of the remaining 134 articles were assessed for eligibility and provided 43 relevant publications for the systematic literature review (21 WoS, 14 Scopus, and 8 Google Scholar). Regarding the full-text screening, the excluded articles covered climate change-related issues without linking them to trade agreement, or the major focus of the studies was irrelevant (dealing only with decarbonization, energy policy, emission trading system, climate agreements, etc.). The applied PRISMA selection method (Moher et al. 2009) guaranteed that all the included articles are directly linked to the research question; therefore, they provide the opportunity for a detailed analysis of the trade–climate nexus.

Table 1 presents the impact of the articles analyzed measured by the citations in the corresponding databases. Based on these data, Nordhaus (2015), Yunfeng and Laike (2010), and Liddle (2017) were the most-cited authors in WoS.

Table 1. The impact of the articles measured by total citations in relevant databases.

WoS		Scopus		Google Scholar	
Authors	Total Citation	Authors	Total Citation	Authors	Total Citation
Nordhaus 2015	233	Barrett 2011 *	18	Yasmeen et al. 2018	33
Yunfeng and Laike 2010	182	Ackrill and Kay 2011 *	17	Shapiro 2020	16
Liddle 2017	75	Dong and Whalley 2010 *	15	Nemati et al. 2019	15
Beccherle and Tirole 2011	34	Dong and Whalley 2011 *	14	Balogh and Jámor 2020	13
Böhringer et al. 2014	24	Himics et al. 2018 *	10	Friel et al. 2020	10
Morin et al. 2018	24	Guevara et al. 2018 *	6	Chen 2017	1
Larch and Wanner 2017	11	Khourdajie and Finus 2020 *	5	Leal-Arcas 2018	0
Morin and Jinnah 2018	10	Young 2017	4	Liao 2017	0
Cai et al. 2013	9	Kuhn et al. 2019 *	2		
Hufbauer and Kym 2010	9	Dissou and Siddiqui 2013 *	2		
Fouré et al. 2016	7	Fang 2019	1		
Kirchner and Schmid 2013	7	Laurens et al. 2019 *	1		
Meyer 2017	7	De Melo and Solleder 2020 *	0		
Sauquet 2012	6	Monkelbaan 2017 *	0		
Avetisyan 2018	4				
Henschke 2012	4				
Blandford et al. 2014	2				
Low and Murina 2010	2				
Mathews 2016	1				
Montaga et al. 2020	0				
Yu et al. 2011	0				

Note: * articles are appeared in WoS as well. Source: Authors' composition.

The following chapter analyses the selected publications.

3. Results

Based on the 43 relevant articles, the existing literature was classified into three main categories: (i) trade negotiations and agreements, (ii) role of trade relations in CO₂ emissions reduction, and (iii) impacts of climate-related policy measures on trade. Furthermore, the authors were classified and grouped according to three main categories and associated concepts (Table 2).

Table 2. The three category-related notions and authors.

Trade Negotiation and Agreements			Role of Trade Relations in Emission Reduction	Effects of Climate-Related Policy Tools on Trade
trade liberalization elimination of trade barriers tariff reductions trade cooperation	WTO rules RTA, PTA NAFTA EGA	agricultural trade liberalization	trade related CO ₂ reduction ratification decision of trading partners emissions embodied in trade	border carbon adjustment carbon tariffs carbon pricing
	Ackrill and Kay (2011) Chen (2017) De Melo and Solleder (2020) Dissou and Siddiqui (2013) Fang (2019) Guevara et al. (2018) Henschke (2012) Hufbauer and Kim (2010) Laurens et al. (2019) Liao (2017) Meyer (2017) Monkelbaan (2017) Morin and Jinnah (2018) Morin et al. (2018) Young (2017)	Blandford et al. (2014) Himics et al. (2018) Kirchner and Schmid (2013) Balogh and Jámbor (2020)	Laurens et al. (2019) Cai et al. (2013) Guevara et al. (2018) Sauquet (2012) Larch and Wanner (2017) Yunfeng and Laike (2010)	Khourdajie and Finus (2020) Fouré et al. (2016) Avetisyan (2018) Böhringer et al. (2014) Khourdajie and Finus (2020) Larch and Wanner (2017) Mathews (2016) Montagna et al. (2020) Shapiro (2020)

Source: Authors' composition.

Trade negotiation-related concepts (i) were linked with trade liberalization, elimination of trade barriers and tariff reduction, as well as changing the rules of WTO. Furthermore, this analyses the role what the North American Free Trade Agreement (NAFTA), the Regional Trade Agreements (RTAs) and the Preferential Trade Agreements (PTAs) played in emission reduction. Moreover, agricultural trade-related issues are also discussed under this category.

The category of trade relations (ii) was associated with influences of trade cooperation in emissions reductions, the impacts of the trading partners' ratification decision, trade-related CO₂ reduction and carbon emission embodied in trade.

Climate-related policy tools (iii) cover the subtopics of border carbon adjustments and analyze the effects of carbon tax or tariffs on trade.

Most of the scholars (10) researched the environmental effects of trade liberalization and the results of WTO negotiation (15) by assessing the possible impact of tariff reductions and the elimination of trade barriers. They also discussed agricultural trade (4) and the environmental issues of the North American Free Trade Agreement (2), MERCOSUR, Regional Trade Agreements and Preferential Trade Agreements, and Trans-Pacific Partnership as a subtopic. Articles dealing with trade relations (7) and climate–trade-related policy tools (12) were also discussed in the selected literature.

Exploring the applied methodologies, general equilibrium models (e.g., GTAP and MIRAGE), simulations (Monte Carlo, Stackelberg game, and climate policy game), panel regression (comprising Environmental Kuznets Curve), and partial equilibrium (CAPRI) models were the most widely used technics. This indicates that economic, econometric and mathematical modelling are the most popular ways of analyzing the relationship between trade agreements and climate change in economics (Figure 2).

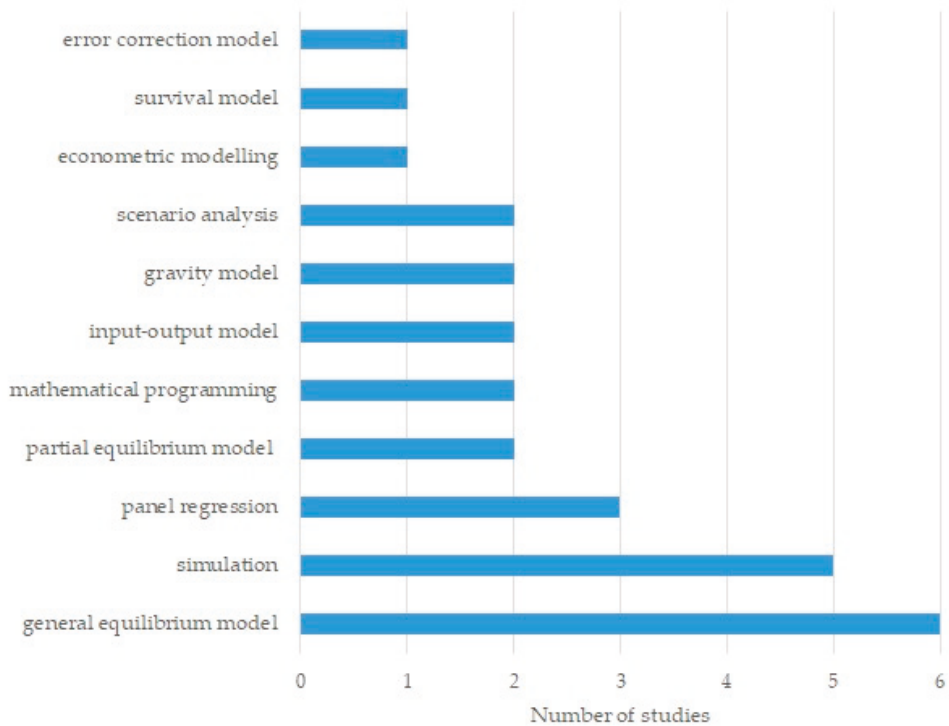

Figure 2. The applied methodologies by the reviewed literature. Source: Authors’ composition.

Most articles addressed various industries at the same time (17). Among the articles covering specific industries, the energy industry (10) was the most frequently studied, followed by the agricultural and fishery sector (9). Services (6) were the least investigated among the analyzed industries (Table 3).

Table 3. Analyzed industries.

Energy Industry	Agriculture and Fishery	Services	Various Industries
			Barrett (2011)
			Böhringer et al. (2014)
			Cai et al. (2013)
Ackrill and Kay (2011)	Balogh and Jámbor (2020)	Avetisyan (2018)	De Melo and Solleder (2020)
Böhringer et al. (2014)	Blandford et al. (2014)	Barrett (2011)	Dissou and Siddiqui (2013)
Fang (2019)	Dong and Whalley (2010)	Böhringer et al. (2014)	Dong and Whalley (2010)
Guevara et al. (2018)	Dong and Whalley (2011)	Chen (2017)	Dong and Whalley (2011)
Larch and Wanner (2017)	Fouré et al. (2016)	Dong and Whalley (2011)	Henschke (2012)
Leal-Arcas (2018)	Himics et al. (2018)	(2011)	Kuhn et al. (2019)
Mathews (2016)	Kirchner and Schmid (2013)	Dong and Whalley (2020)	Larch and Wanner (2017)
Meyer (2017)	Larch and Wanner (2017)	Khourdajie and Finus (2020)	Low and Murina (2010)
Morin and Jinnah (2018)	Young (2017)		Monkelbaan (2017)
Sauquet (2012)			Morin et al. (2018)
			Nemati et al. (2019)
			Nordhaus (2015)
			Shapiro (2020)
			Yu et al. (2011)

Source: Authors’ composition.

Discovering global-level issues or providing wide geographical coverage of trade–climate nexus were a general aim of the analyzed literature. The American, Asian, and European regions were overrepresented, while the trade-related climate issues of the African and the Pacific regions were underrepresented in the selected literature (Table 4). This indicates that the African and the Pacific regions can be identified as a potential research gap in this topic.

Table 4. Analyzed regions by the studies.

Analyzed Countries and Regions	Authors
Europe	
Austria, Marchfeld region	Kirchner and Schmid (2013)
Norwegian agriculture	Blandford et al. (2014)
European Union	Fouré et al. (2016)
European Union agriculture	Himics et al. (2018)
America	
Canada and the United States	Dissou and Siddiqui (2013)
NAFTA, United States–Mexico	Yu et al. (2011), Guevara et al. (2018)
NAFTA, MERCOSUR, AUSFTA	Nemati et al. (2019)
United States–Mexico–Canada Agreement (USMCA)	Laurens et al. (2019)
Asia	
China foreign trade	Yunfeng and Laike (2010)
China, US–China trade	Fang (2019)
Pacific	
Trans-Pacific Partnership	Young (2017)
Africa	
East Africa (Kenya, Tanzania, and Uganda)	Liao (2017)

Source: Authors' composition.

3.1. The Role of Trade Relations in Emissions Reductions

Most of the authors highlighted the need for climate coalitions and incorporating trade restrictions in multilateral climate agreements addressing emission reduction.

Reducing tariffs on low-carbon products and setting penalties on non-member countries of regional trade agreements can force harmonizing trade and climate change regimes. However, the effects of carbon motivated regional trade agreements are often small even with penalty mechanisms (Dong and Whalley 2010; Dong and Whalley 2011).

Investigating free trade, Nordhaus (2015) argues that climate coalitions in agreements are not stable without sanctions against non-participant countries. In turn, country groups acting together as a climate club can apply trade penalties on non-participants and create a large, stable coalition with a high level of CO₂ abatement.

In other scholar's opinion, greenhouse gas emissions can be reduced by incorporating trade restrictions without losing gains from multilateral trade cooperation (Barrett 2011). Regarding climate coalitions, Kuhn et al. (2019) confirmed that emission reduction is higher, consumption patterns are more environmentally friendly, and coalition welfare is much more improved compared to the single-issued environmental agreements.

When free trade agreements are between only developed or developing countries, there is no environmental damage, and these types of agreements can be beneficial for the environmental quality in the long run. However, when developing and developed countries are in a trade agreement, overall environmental quality decreases due to the increased GHG emissions. The effect of free trade on the environment depends on the relative income levels of the countries involved in the agreement. Least developed countries need to be aware of the trade-off between increased economic growth and higher GHG emissions caused by the free trade (Nemati et al. 2019). Leal-Arcas (2018) added that greater cooperation is required between developed and developing countries to create

stable agreements, boosting renewable energy trade. Higher engagement of the major GHG emitters (the US, the EU, and China) is needed to support the transition to renewable energy and the harmonization of carbon pricing.

Cai et al. (2013) found that larger countries are more likely to participate in climate agreements because a given output reduction leads to a higher reduction in global average temperature.

Investigating the impacts of trade relations on emission reduction, Sauquet (2012) showed that countries often follow the decision of their trading partners. This is induced by the reputation and competitiveness of their trading partners. Therefore, trade relations in environmental treaties are crucial factors that should be accounted for.

Yunfeng and Laike (2010) estimated the CO₂ emission embodied in the Chinese foreign trade. They showed that more emissions were exported than products consumed domestically due to carbon embodied in products. Consequently, a significant carbon emission occurs at the Chinese trading partners that should be considered in any new agreements.

To conclude, incorporating trade restrictions in agreements, setting penalties on non-member countries, and creating a climate coalition can strengthen climate–trade cooperation and enhance emissions reduction without losing the gains from trade cooperation. In this context, the main purpose of the trade restrictions is to enforce the agreement and encourage participation in emission reduction. In contrast, the emission reduction is often limited even with a penalty mechanism. Thus, further research should address the optimal characteristic of the trade–climate cooperation, adequate trade restrictions to stimulate efficient GHG emissions reductions. From this aspect, developed countries should take higher responsibility because these countries are the major emitters and they have more opportunities to invest into green energies. Trade relations have a crucial role in environmental treaties influencing the decision making of all trading partners. Furthermore, in trade negotiations, trade embodied carbon emission should also be analyzed to avoid the potentially harmful environmental impacts of a free trade agreement.

Agricultural Trade and Climate Nexus

Kirchner and Schmid (2013) indicated that the elimination of trade barriers and agri-environmental payments led to a substantial environmental deterioration in small countries and regions. Agri-environmental payments can contribute to the battle against climate change and emission reduction.

Second, the literature review revealed that trade liberalization has only modest effects on agricultural emissions. The combination of agricultural trade liberalization and carbon pricing in the European Union increased emission leakage in other parts of the world and undermined global climate mitigation goals (Himics et al. 2018).

Third, agricultural trade liberalization often influences the environment unfavorably. Tropical deforestation, biodiversity loss, soil erosion, and excessive water use were mentioned as the major problems associated with accelerating agri-food trade. The most significant impact of deforestation and biodiversity loss were caused in Brazil, India, Indonesia, and Sub-Saharan Africa (Balogh and Jámbor 2020).

Due to their weak environmental standards, free trade agreements also drive intensive farming methods with high external inputs, such as energy-intensive synthetic nitrogen fertilizers, which lead to agricultural land use change-related deforestation, soil degradation, and high biodiversity loss in tropical regions (Heyl et al. 2021).

In conclusion, the effect of trade liberalization on agricultural GHG reductions is ambiguous: it has only modest effects on air pollution, but it increases emission leakage and environmental degradation. Trade liberalization linked to the reduction of tariffs and trade barriers is also criticized, especially by developing countries.

After having discussed the relationship between trade and climate change mitigation, the next section addresses the environmental policy of the WTO and its negotiations.

3.2. WTO Rules and Negotiations

The general approach under the WTO rules is to acknowledge that some degree of trade restriction may be necessary to achieve certain policy. Several WTO rules are relevant to measures that aim at climate change mitigation. These measures include border measures, the prohibition of border quotas, the general principle of non-discrimination, rules on subsidies or technical regulations, disciplines relevant to trade in services, imposing general obligations such as the most-favored-nation treatment, or rules on trade-related intellectual property rights (WTO 2021a).

Regarding the WTO rules, several weaknesses reflected in the analyzed literature relating to environmental issues. The WTO Doha Round proposals on agriculture did not generate significant emissions cuts because emissions reduced by cutting back agricultural production via free trade did not lead to more climate-friendly production methods (Blandford et al. 2014). The arrangement of agri-environmental payments with WTO trading rules remains an important issue in the trade-environment debate (Kirchner and Schmid 2013).

De Melo and Solleder (2020) concluded that the Doha Round negotiation did not lead to a sufficient reduction of tariffs. Negotiations broke in 2016, consequently, adjusting tariffs under the Environmental Goods Agreement (EGA) were insufficient to mitigate climate change. They emphasized the urgent need for transformational changes in the WTO contracts to take transnational externalities and public goods into account. Reaching successful trade agreements also requires delegating independent scientific experts to the negotiating authority to adjust the WTO rules.

Moreover, the world largest fossil fuel exporters, many of them are located in the Middle East, had not historically been members of the World Trade Organization (Meyer 2017). In addition, the rise of state-owned enterprises in many oil-producing countries can cause a problem. Hence, the WTO rules on subsidies are inadequate to deal with the restriction of fossil fuel trade.

Assessing the impact of the WTO rules on carbon emission, we can see that the effects of tariff reductions on environmental goods are low, transnational externalities and public goods are not included in the agreements.

Regarding trade liberalization, more proposals are required to address climate change. Furthermore, the analyzed literature focused mainly on trade barriers, with limited interests in what rules have performed well and why in climate mitigation policy (Friel et al. 2020).

Trade barriers are identified as the largest obstacles to the dissemination of low-carbon energy technologies and associated services worldwide. Lower trade barriers on environmental goods might have advantages for both developed and developing countries. Finally, to date, Middle East fossil fuel exporters have not joined the World Trade Organization. All these issues make the WTO negotiation and trade rules insufficient to achieve a significant emission reduction and establish stable rules for environmental protection.

3.3. Regional and Bilateral Trade Agreements

Regional trade agreements are reciprocal preferential trade agreements between two or more trading partners (WTO 2021b). Liao (2017) argues that regional trade agreements can contribute to pursuing harmonization and cooperation under the WTO. The RTAs can provide opportunities for a group of countries with concrete commitments and rules to tackle climate change.

Analyzing the NAFTA and the United States–Mexico–Canada Agreement, many environmental concerns were highlighted. According to Yu et al. (2011), the free trade between the United States and Mexico contributes to increasing GHG emissions in both countries. As the United States is the top destination for Mexican exports, and there is an extensive intra-company trade between those two countries, the “pollution haven” hypothesis holds in this trade relation. Exploring the energy-related CO₂ emission between NAFTA countries shows that NAFTA has not built an integrated energy system to reduce energy-related CO₂ emissions (Guevara et al. 2018). The United States–Mexico–Canada Agreement (USMCA)—known as

the renegotiated NAFTA—has only made limited contributions to environmental protection. This agreement primarily replicated most of the environmental provisions included in the previous agreement. Moreover, the USMCA scaled back environmental provisions related to multilateral environmental agreements (Laurens et al. 2019). In terms of trade, the literature confirmed that NAFTA allows only limited space for environmental protection and did not comply with international climate mitigation goals.

3.4. Unilateral Trade Preferences

Limited number of studies addressed how unilateral trade preferences influence climate change. Preferential Trade Agreements (PTAs) are unilateral trade preferences in the WTO. They are generally created between a developed and a developing nation where developed countries favor developing ones by reducing import tariffs (WTO 2021c). Morin and Jinnah (2018) revealed that climate provisions in PTAs are sometimes specific and enforceable, in contrast, these provisions remain weakly legalized, fail to implement broadly in the global trade system. Moreover, the largest GHG emitters (the US, India, China, and Canada), except for the European Union, included only a few weak climate-related provisions. Hence, provisions in PTAs are not effective in climate mitigation as they address climate change indirectly.

3.5. Different Policy Measures in the Trade–Climate Nexus

Global-level policies provide an opportunity for global emissions reduction. However, Barrett (2011) concluded that the Kyoto Protocol had no trade-restrictive elements; therefore, it did not reduce GHG emissions. He emphasized that any future climate agreements should restrict trade in order to protect the trading system. Regional cap-and-trade systems may lead to a global climate agreement (Beccherle and Tirole 2011).

Blandford et al. (2014) argued for either a more effective trade liberalization or carbon taxes. Although both decrease agricultural activity but increase economic welfare in return. Encouraging the trade of low carbon-intensive goods by tariffs results in lower emissions, but this impact would be relatively small and ambiguous (Dong and Whalley 2010). Dong and Whalley (2011) identified its explanation, i.e., economic growth is a more significant reason for higher emissions than trade. Based on a model analysis, they also pointed out that both custom unions and free-trade agreements reduce emissions more than carbon motivated trade arrangements.

Avetisyan (2018) suggested the global GHG tax; however, a sector-specific tax performs worse than an all-sector tax, especially in developing regions subsidized from tax revenues. Due to the highly interconnected international trade, applying a consumption-based CO₂ accounting system would help to deal with the exported CO₂ emissions problem (Yunfeng and Laike 2010).

Finally, Mathews (2016) proposed the integration of trade (WTO) and climate (United Nations Framework Convention on Climate Change) issues to promote green products and processes.

WTO Rules Addressing Subsidies

Several countries apply trade subsidies to encourage exports and domestic market sales through direct payments. The WTO Agreement on Subsidies and Countervailing Measures (ASCMs) is a multilateral discipline that regulates the provision of subsidies, and the use of countervailing measures to offset losses caused by subsidized imports (WTO 2021d). The provision of emissions permits issued by countries in carbon trading schemes usually interacts with subsidies in the WTO ASCMs (Henschke 2012). Hence, countries need to avoid disproportionately favoring industries exposed to trade in the distribution of carbon emissions permits. Otherwise, they risk that permit distributions may become prohibited under the ASCMs.

Analyzing RTA proposals including the fishery subsidies in the Trans-Pacific Partnership, Young (2017) found that certain subsidies may contribute to overfishing or illegal

fishing. This should be revised during the arrangement of RTAs. However, fishery subsidies are special, as a majority of them are granted by net fish importers, such as Japan, to increase domestic production, and these subsidies mostly impact the access to the resources (Young 2017).

Arrangements of trade subsidies and sanctions were the main obstacles to reach an agreement at the South African UNFCCC conference in 2011 (Hufbauer and Kim 2010).

Similar to the fossil fuel subsidy reform, fishery subsidy is a complex issue with at least four dimensions: social, political, cultural, and environmental/ecological (Young 2017). According to Young (2017), every reform process should be based on the interaction between the different regimes and its key issues are openness, transparency, and contestability. In some cases, the subsidies allowed by the WTO led to overexploitation of natural resources. Therefore, the direct environmental impacts of trade subsidies should be investigated, especially in regions with high biodiversity resources.

The subsequent section discusses the climate-related policy tools of trade.

3.6. Effect of Climate Policy Measures on Trade and Economic Welfare

The Border Carbon Adjustment (BCA) is interpreted as an important climate-related policy measure. This taxes imported goods based on their carbon emission to limit emissions leakage and support domestic industries that produce goods with lower GHGs than the potentially cheaper but more pollutant imports (OECD 2020).

As a trade measure, BCA has many disadvantages and may be opposed by any WTO members under the dispute settlement mechanism. BCA implies export losses to the trading partners; therefore, it decreases agri-food exports, meanwhile leading only to a small decrease in global emissions (Fouré et al. 2016). In contrast, Khourdajie and Finus (2020) show that BCAs without restrictive membership can lead to stable climate agreements, associated with large global welfare gains. BCA creates stable climate agreements if climate treaties do not restrict membership, but this usually implies export losses for agricultural trading partners.

Import adjustments can be made compatible with the WTO obligations, while export refunds may constitute an illegal subsidy under the ASCMs, which has no exceptions for environmental purposes (Böhringer et al. 2014).

Evaluating the effects of carbon tariffs on trade, Larch and Wanner (2017) experienced with reduced welfare, mostly in developing countries, if trade decreases due to a carbon tariff. In turn, if a high tariff falls or is eliminated, carbon emissions are not shifted from countries with higher carbon taxes to countries with lower carbon taxes indicating the reduction of carbon leakage.

Shapiro (2020) revealed that if countries imposed similar tariffs and non-tariff barriers to trade (NTBs) on clean and dirty industries, global CO₂ emissions would fall, while real income would not change. As the final consumers are generally not well-organized, countries end up with greater protection on clean products and less protection on polluting goods.

According to Dong and Whalley (2011), most of the carbon motivated RTAs improve economic welfare. However, if countries with high emission are involved, carbon-based custom unions are even more effective. In the case of the broader climate agreements, Khourdajie and Finus (2020) highlighted that non-signatories enjoy various economic benefits without paying any costs. This includes environmental benefits, as well as economic benefits, if some parts of a ratifier's production are relocated to a non-ratifier country. Based on their modeling results, Montagna et al. (2020) highlighted a potential side-effect, namely international environmental agreements may lead to a welfare reduction in the non-participating countries.

4. Discussion

The reviewed literature discussed several problems hindering the advantageous effects of trade agreements on mitigating climate change. The main arguments against the effectiveness of trade liberalization on emission reduction are diverse. First, environmental

degradation occurs (deforestation, biodiversity loss) caused by agricultural trade liberalization, especially in tropical regions (Balogh and Jámor 2020). From this aspect, the combination of agricultural trade liberalization with carbon pricing increases emission leakage, especially in the agricultural sector of the non-EU countries (Himics et al. 2018). Furthermore, the elimination of trade barriers and agri-environmental payments causes substantial environmental damage at the regional level, as in the example of the Marchfeld region in Austria (Kirchner and Schmid 2013).

Second, the potential weaknesses of the WTO regulations are also highlighted. As a result of the Doha Round, the average tariff reduction on Environmental Goods under the Environmental Goods Agreement (EGA) was low and insufficient to mitigate climate change (De Melo and Solleder 2020). Moreover, the WTO Doha Round proposals on agriculture did not have a significant impact on GHG emission reduction. The impacts of the emissions reduction on agricultural activity depend on whether a climate agreement allows a credit for carbon sequestration activities on land extracted from agricultural production (Blandford et al. 2014). As reciprocal litigation exists in the renewable energy sector at the national and international level, the subsidies allowed under WTO are rarely used to stimulate the renewable energy sector (Meyer 2017) and may lead to overexploitation of natural resources.

Although PTAs include several environmental provisions, they remain weakly legalized and are not often approved by the world's largest GHG emitters. Neither the US, India, China, nor Canada include a significant number of climate change provisions in their PTAs (Morin and Jinnah 2018). Even including a penalty mechanism, the carbon motivated regional trade agreements only slightly reduced global emissions, and trade policy is likely to be a minor consideration in climate change containment (Dong and Whalley 2010; Dong and Whalley 2011). Yunfeng and Laike (2010) call attention to the damaging effects of export-oriented production on the environment in China.

Finally, the climate and trade negotiations are taking place under great uncertainty, and voluntarism at the national level results in an insufficient effort to address climate change (Low and Murina 2010).

The literature point outs that the effectiveness of the trade negotiations on climate change is weak because trade liberalization may help to stimulate renewable energy trade, but might also cause environmental concerns such as deforestation, biodiversity loss, intensive agricultural production, and carbon leakage. The carbon emission leakage is often associated with developed countries' trade (emission embodied in trade) and climate mitigation policies (environmental provisions, carbon tax, border carbon adjustments). This results in the relocation of polluting industries to the developing and the least developed countries (e.g., Africa, South America, or Asia). The largest beneficiaries of the trade agreements are mostly the largest GHG emitters, such as the US, the EU, and China. They often outsource their industrial and agricultural production to developing countries with low environmental standards and export back the processed products.

In line with the findings of the literature review, trade liberalization under WTO at the present stage is unable to change production methods to be environmentally friendly; therefore, reconsideration of trade regulation and new renegotiations, especially among developing and developed countries (e.g., US–Latin America, US–Asia, and EU–Africa), are needed. In this context, trade regulation should account for production methods, all resources used during production, and the distance and method of product transportation from the producing country to the final consumers.

However, a few mandatory standards concerning deforestation were established in trade agreements (e.g., Mercosur, CETA, and the EU–Vietnam Free Trade Agreement). These agreements lack a comprehensive legal framework to enhance environmental protection. Additionally, they have weak dispute settlement mechanisms to ensure compliance with sustainability measures, which limit their effectiveness (Heyl et al. 2021).

On the other hand, trade agreements can encourage emission reduction by applying restrictions on non-member countries, lowering tariffs on environmental goods, stimulating

renewable energy (excluding biofuels and biomass from wood), and eliminating fossil fuel subsidies. All these efforts can be successful only if they are also approved by the largest GHG emitters and included in their foreign trade policies, enforced by their companies operating abroad. Finally, the harmonization of the trade agreements with national climate policies is needed to avoid counteractive measures and to make them compatible with global environmental policies and goals (e.g., the Paris Agreement).

Table 5 summarizes the problems hindering the success of trade agreements in reducing GHG emission and solutions offered to tackle them.

Table 5. Problems of the trade agreements and solutions offered.

Issue	Problems Detected	Solutions Offered
Impact of trade-related carbon adjustments		
Carbon tax	Causes intensification of production.	Imposing a carbon tax might lead to output reduction.
Carbon tariff	Trade decreased, welfare reduced in developing countries.	If countries imposed similar tariffs and NTBs to trade on clean and dirty industries, global CO ₂ emissions would fall, while real income would not change.
Carbon leakage	The combination of agricultural trade liberalization and carbon pricing increases emission leakage, especially in non-EU countries.	Carbon tariffs enable the reduction of global emissions by altering the production within and across countries, reducing carbon leakage.
Border carbon adjustments	BCA on imports of energy-intensive products in the EU indicates a small decrease in global emissions. May be opposed by a WTO member under the dispute settlement mechanism. Would imply export losses to the trading partners, could decrease agri-food exports.	BCA without restrictive membership can lead to stable climate agreements, associated with large global welfare gains.
Emission embodied in trade	Higher Chinese emissions were exported by carbon embodied in products than products consumed in China domestically.	Controlling export-oriented products.
WTO rules and negotiations		
WTO tariff reduction	Low average tariff reduction under WTO is insufficient to mitigate climate change.	Higher tariff reduction of environmental goods.
Subsidies	The subsidies allowed under WTO are rarely used to stimulate renewable energy and leads to overexploitation of natural resources (e.g., in the Trans-Pacific Partnership, certain fishery subsidies may contribute to overfishing or illegal fishing).	Reconsideration of trade regulation and renegotiations, especially between developing and developed countries, are needed.
Sustainable energy trade	Biofuels and biomass production may lead to increased deforestation, biodiversity losses in tropical areas and developing southern countries (Mexico, Brazil, India, Indonesia and Sub-Saharan Africa).	Biofuels and biomass production should be treated differently or restricted in trade policy.
WTO trade negotiation	Trade negotiations take place under great uncertainty and are often halted before coming to a conclusion	Delegating independent scientific experts to trade negotiation may help change rules and reduce emissions.

Table 5. Cont.

Issue	Problems Detected	Solutions Offered
Trade agreements		
Emission reduction	Trade-related emission.	Creating universal agreements with differentiated and clear obligations can stimulate emission reduction.
Trade barriers	Technical barriers to trade.	Elimination of trade barriers on low-carbon and environmentally friendly products contributes to trade-related emission reduction. Motivates sustainability to be more WTO-compatible.
Trade restrictions	Trade penalties.	Applying trade penalties on nonparticipants of an agreement can stimulate their climate abatement policy. Small trade penalties on non-participants of trade agreements create a stable climate coalition with potentially high levels of CO ₂ reduction. Country groups acting as a climate club, applying trade penalties on non-participants, creates a stable coalition with a high level of abatement.
Externalities	Environmental externalities.	Incorporating transnational externalities and public goods in trade agreements are needed.
Interrelation of environmental and trade agreements	Lack of harmonization between environmental and trade agreements.	Environmental and trade agreements must be sufficiently integrated at the national and international policies to improve environmental quality and attain the benefits of free trade.
Climate provisions in PTAs	Climate provisions in PTAs offer limited progress, remain weakly legalized, and are not adopted by the largest GHG emitters.	Carbon-based custom unions are more effective than carbon motivated RTAs if high emission countries are involved.
Trade liberalization	Modest effects of trade liberalization on agricultural GHG emissions. Doha Round proposals on agriculture did not generate significant emissions reductions. Elimination of trade barriers and agri-environmental payments leads to substantial environmental damage in small countries.	Trade agreements are able to encourage emission reduction by applying restrictions on non-member countries, lowering tariffs on environmental goods, and stimulating renewable energy.

Source: Authors' composition.

Regarding solutions, different trade and WTO-related issues were posted. When free trade agreements are implemented between only developed or only developing countries, there is no environmental damage. However, when there are both developing and developed countries in a trade agreement, the environmental quality decreases (Nemati et al. 2019). Accordingly, greater cooperation would be necessary between developed and developing countries' trade policies to increase renewable energy trade (Leal-Arcas 2018).

In the WTO contracts, environmental externalities and public goods have to be taken into account to measure the additional environmental costs of polluting activities. Moreover, WTO members should pursue similar climate-friendly policies (De Melo and Solleder 2020) to harmonize their environmental standards. Biofuels and biomass trade should be treated differently from renewable energy in trade policy since their production might cause environmental damages. Technical Barriers to Trade help to establish WTO-compatible, sustainable principles (Ackrill and Kay 2011), protect consumers and preserve natural resources. The arrangement of agri-environmental payments with WTO trading rules is

crucial in the effective trade–environment debate, especially for small countries (Kirchner and Schmid 2013). Delegating scientific experts to negotiations can change the poorly specified WTO trading rules, reaching an agreement on tackling NTBs and environmental services (De Melo and Solleder 2020).

Considering trade relations, small trade penalties on non-participants of trade agreements can force a stable climate coalition with a potentially high CO₂ reduction (Nordhaus 2015). In addition, universal trade agreements with clear obligations offer the best solution for stimulating efficient emission reduction (Low and Murina 2010). If climate treaties are designed strategically, the threat to restrict trade will suffice to enforce an agreement (Barrett 2011). When a country's participation in joint emission reduction is higher, the consumption patterns are more environmentally friendly, and welfare is much more improved (Kuhn et al. 2019). Considering the welfare effects of climate policy measures, when countries impose similar tariffs and barriers on environmentally friendly and polluting industries, global CO₂ emissions tend to fall, while incomes do not change (Shapiro 2020). A nonrestrictive border carbon adjustment can lead to stable climate agreements and significant global welfare gains (Khourdajie and Finus 2020), while carbon tariffs enable global emissions reduction by altering the production within and across countries, resulting in the reduction of carbon leakage (Larch and Wanner 2017). In contrast, imposing a carbon tax might lead to output reduction and the intensification of production (Blandford et al. 2014). Mobilizing environmental goods, services, and technology to achieve the United Nations' Sustainable Development Goals is also needed (Monkelbaan 2017). Finally, the democratic countries facing import competition are more willing to include environmental provisions in their trade agreements (Morin et al. 2018).

5. Conclusions

In the climate–trade dialogues, a limited number of systematic reviews are dedicated to evaluating the effectiveness of trade agreements and negotiations on climate mitigation policy. This research aims to contribute to the existing literature by examining the role that various trade agreements and trade-related policy measures play in carbon emissions. This systematic literature review provides an overview of the recent literature in economics on the climate–trade nexus for the period of 2010–2020. After the initial research, removing duplicates, and evaluation of abstracts, the review of the full texts results in 43 relevant studies closely associated with the topic. Regarding the research methods, general equilibrium models, simulations, and panel econometrics were the most commonly applied in the empirical literature.

Based on the reviews, many scholars agree that trade agreements can support the mitigating effects of climate change. However, several sceptics emphasized the weaknesses of trade agreements and the WTO negotiation in decreasing air and environmental pollution. Regarding the problems hindering trade agreements to reduce the effects of climate change, many authors underlined that the effectiveness of the negotiations is fragile because they take place under high uncertainty, and countries often favor their national interests. Developing countries have a weaker position regarding climate–trade negotiations compared to the lobbying power of developed countries. The largest beneficiaries of the agreements are primarily the largest GHG emitters. They include only a limited number of climate-related provisions in their trade agreements or have not joined the WTO (oil-producing countries in the Middle East).

Low average tariff reduction under WTO negotiation on environmental goods is unproductive on emission reduction. Subsidies are allowed under WTO in some cases (e.g., fishery industry), and they may lead to overexploitation of natural resources. Energy sources such as biofuels and biomass from wood and timber cause deforestation; therefore, they should be separated from renewable energy in environmental provisions.

Carbon leakage, deforestation, and biodiversity loss are significant climate–trade related issues, and they are usually caused by increasing global trade, intensification of production, and national agricultural policies. In turn, these impacts occur mostly in

developing countries (outside the European Union or the US) such as India, Brazil, Mexico, and Sub-Saharan Africa.

The analyzed literature also offers policy solutions that contribute to GHG emission reduction and make WTO trade policy more compatible with the UN global climate mitigation goals. The most significant measures identified were the application of small trade restrictions on non-member countries, lowering tariffs on environmental goods, subsidizing renewable energy trade, international carbon tariff harmonization, unrestrictive border carbon adjustment, country groups' climate cooperation and changing policies indicating carbon leakage. Evaluating climate–trade-related policy measures, border carbon adjustment without restriction can lead to more stable climate agreements. Moreover, carbon tariffs can reduce emissions by altering the countries' production composition and reduce trade flows. A carbon tax might lead to output reduction, but it could stimulate the intensification of production, though its effect is controversial for climate change mitigation. Furthermore, greater trade cooperation is vital between developed and developing countries in climate–trade negotiations to allocate renewable energy resources fairly and harmonize tariffs and barriers of fossil energy sources. The issues of transnational externalities and policies indicating carbon leakage should also be addressed in the WTO negotiations. Harmonizing agri-environmental payments with WTO trading rules is crucial in trade–environment debate. Delegating scientific experts to the negotiation helps achieve more environmentally friendly WTO rules. Applying a consumption-based CO₂ accounting system would help document the exported CO₂ emissions (Yunfeng and Laike 2010).

In conclusion, the effectiveness of trade agreements needs to be improved by refining WTO trading rules, subsidizing renewable energy, and limiting fossil fuel trade through different tariffs. Incentives of renewable energy sources and environmental goods should also include trade policy, environmental provisions, and tariff reduction both in developed and developing countries. Moreover, promoting renewable energy trade may have negative effects on emissions if biofuels and biomass are also included. This may lead to increased deforestation and biodiversity loss in tropical regions of Asia, Africa, and Latin America.

Sub-Saharan Africa, North Africa, Latin America, the Middle East, and the Caribbean regions need to reform their institutional framework, leading to trade-led growth activities that encourage innovation, use cleaner technologies, and increase environmental quality (Yasmeen et al. 2018). Moreover, the Association of Southeast Asian Nations should implement policies that encourage sustainable trade and reduce environmental deterioration (Solomon and Khan 2020).

Finally, the largest CO₂ emitters (the US, China, the EU, India, and Canada) should take the highest responsibility in following the WTO rules, establishing high environmental provision in their trade policies to avoid carbon leakage (relocation of polluting industries), emission embodied in trade (transportation), and trade-related environmental damage (overexploitation of natural resources). They also have a responsibility in reducing CO₂ emissions in other parts of the world, as long as they are the engines of the world economy and trade, and influence the scale, method, and technology of production.

As of the practical implications of the paper, findings support that more sustainable trade agreements in trade negotiations can be created by improving the environmental provision and effectiveness of trade policy in emission reduction and selecting a set of adequate trade-related policy measures. However, as the trade and climate-related problems differ from country to country, solutions should be case-specific. Therefore, at least the type of the problem (trade-related carbon adjustments, WTO rules, and types of trade agreements) and the relations of trading partners (developing vs. developed countries) should be taken into account.

One of the main limitations of this study is the article selection method and the analyzed period. We used Scopus, WoS, and Google Scholar; therefore, our results are limited to these sources. Using other sources, e.g., ScienceDirect, may increase the number of potential articles and enrich our findings. Another possible future path could be the use of an extended research period and application of a META analysis. Analyzing the

environmental impacts of trade agreements in the African and Pacific regions has been identified as a potential direction for future research.

Author Contributions: Conceptualization, J.M.B. and T.M.; methodology, J.M.B.; software, J.M.B.; validation, J.M.B. and T.M.; formal analysis, J.M.B.; investigation, J.M.B. and T.M.; resources, J.M.B. and T.M.; data curation, J.M.B.; writing—original draft preparation, J.M.B. and T.M.; writing—review and editing, T.M. and J.M.B.; supervision, J.M.B. and T.M.; funding acquisition, J.M.B. Both authors have read and agreed to the published version of the manuscript.

Funding: This research was funded by the New National Excellence Program of the Ministry for Innovation and Technology from the source of the National Research, Development and Innovation Fund, grant number ÚNKP-20-4-II-CORVINUS_9.

Institutional Review Board Statement: Not applicable.

Informed Consent Statement: Not applicable.

Data Availability Statement: Not applicable.

Acknowledgments: Not applicable.

Conflicts of Interest: The authors declare no conflict of interest.

Notes

- Consumption-based emissions are allocated to countries where goods and services are consumed, and differ from territorial-based emissions, as they exclude national emissions required to produce exported products, instead of including emissions from other countries to import products.

References

- Ackrill, Robert, and Adrian Kay. 2011. EU Biofuels Sustainability Standards and Certification Systems—How to Seek WTO-Compatibility. *Journal of Agricultural Economics* 62: 551–64. [\[CrossRef\]](#)
- Avetisyan, Misak. 2018. Impacts of global carbon pricing on international trade, modal choice and emissions from international transport. *Energy Economics* 76: 532–48. [\[CrossRef\]](#)
- Balogh, Jeremiás Máté, and Attila Jámbor. 2020. The Environmental Impacts of Agricultural Trade: A Systematic Literature Review. *Sustainability* 12: 1152. [\[CrossRef\]](#)
- Barrett, Scott. 2011. Rethinking Climate Change Governance and Its Relationship to the World Trading System. *The World Economy* 34: 1863–82. [\[CrossRef\]](#)
- Beccherle, Julien, and Jean Tirole. 2011. Regional initiatives and the cost of delaying binding climate change agreements. *Journal of Public Economics* 95: 1339–48. [\[CrossRef\]](#)
- Blandford, David, Ivar Gaasland, and Erling Vårdal. 2014. Trade Liberalization versus Climate Change Policy for Reducing Greenhouse Gas Emissions in Agriculture: Some Insights from Norway. *Applied Economic Perspectives and Policy* 37: 418–36. [\[CrossRef\]](#)
- Böhringer, Christoph, Carolyn Fischer, and Knut Einar Rosendahl. 2014. Cost-effective unilateral climate policy design: Size matters. *Journal of Environmental Economics and Management* 67: 318–39. [\[CrossRef\]](#)
- Cai, Yuezhou, Raymond Riezman, and John Whalley. 2013. International trade and the negotiability of global climate change agreements. *Economic Modelling* 33: 421–27. [\[CrossRef\]](#)
- Chen, Zhe. 2017. Research on Application of General Agreement on Trade in Services in Climate Change Mitigation Policies. *International Journal of Science* 4: 300–7.
- Climate Action Tracker. 2020. Temperatures Addressing global warming 2100 warming projections. Available online: <https://climateactiontracker.org/global/temperatures/> (accessed on 10 November 2020).
- De Melo, Jaime, and Jean-Marc Solleder. 2020. The EGA Negotiations: Why They Are Important, Why They Are Stalled, and Challenges Ahead. *Journal of World Trade* 54: 333–47.
- Dissou, Yazid, and Muhammad Shahid Siddiqui. 2013. Regional Trade Agreements, Emissions Bubbles, and Carbon Tariff Harmonization. *Energy Journal* 34: 59–89. [\[CrossRef\]](#)
- Dong, Yan, and John Whalley. 2010. Carbon, Trade Policy and Carbon Free Trade Areas. *The World Economy* 33: 1073–94. [\[CrossRef\]](#)
- Dong, Yan, and John Whalley. 2011. Carbon motivated regional trade arrangements: Analytics and simulations. *Economic Modelling* 28: 2783–92. [\[CrossRef\]](#)
- Fang, Mandy Meng. 2019. *A Crisis or an Opportunity? The Trade War between the US and China in the Solar PV Sector*. Working Paper 19/03. Singapore: NUS Asia-Pacific Centre for Environmental Law. [\[CrossRef\]](#)
- Fouré, Jean, Houssein Guimbard, and Stéphanie Monjon. 2016. Border carbon adjustment and trade retaliation: What would be the cost for the European Union? *Energy Economics* 54: 349–62. [\[CrossRef\]](#)

- Friel, Sharon, Ashley Schram, and Belinda Townsend. 2020. The nexus between international trade, food systems, malnutrition and climate change. *Nature Food* 1: 51–58. [CrossRef]
- Google Scholar. 2020. Available online: https://scholar.google.com/scholar?q=allintitle%3A+climate+change+trade+agreement&hl=en&as_sdt=0%2C5&as_ylo=2010&as_yhi=2020 (accessed on 21 September 2020).
- Griffin, Conor, Diana Hindle Fisher, Ailia Haider, Kamala Dawar, Adam Green, and Gareth Owen. 2019. *Climate Change and Trade Agreements Friends or Foes?* London: The Economist Intelligence Unit Limited, Available online: <https://pages.eiu.com/rs/753-RIQ-438/images/TradeandClimateChange2019.pdf> (accessed on 18 October 2020).
- Guevara, Zeus, Edmundo Molina-Pérez, Edith X.M. García, and Vanessa Pérez-Cirera. 2018. Energy and CO₂ emission relationships in the NAFTA trading bloc: A multi-regional multi-factor energy input–output approach. *Economic Systems Research* 37: 178–205. [CrossRef]
- Henschke, Lauren. 2012. Going it alone on climate change A new challenge to WTO subsidies disciplines: Are subsidies in support of emissions reductions schemes permissible under the WTO. *World Trade Review* 11: 27–52. [CrossRef]
- Heyl, Katharine, Felix Ekaradt, Paula Roos, Jessica Stubenrauch, and Beatrice Garske. 2021. Free Trade, Environment, Agriculture, and Plurilateral Treaties: The Ambivalent Example of Mercosur, CETA, and the EU–Vietnam Free Trade Agreement. *Sustainability* 13: 3153. [CrossRef]
- Himics, Mihaly, Thomas Fellmann, Jesús Barreiro-Hurlé, Heinz-Peter Witzke, Ignacio Pérez Domínguez, Torbjörn Jansson, and Franz Weiss. 2018. Does the current trade liberalization agenda contribute to greenhouse gas emission mitigation in agriculture? *Food Policy* 76: 120–29. [CrossRef]
- Hufbauer, Gary Clyde, and Jisun Kim. 2010. Reaching a Global Agreement on Climate Change: What are the Obstacles? *Asian Economic Policy Review* 5: 39–58. [CrossRef]
- IPCC. 2019. United Nations Climate Change Summit 2019. Available online: <https://www.un.org/en/climatechange/reports.shtml> (accessed on 5 March 2021).
- Khourdajie, Alaa Al, and Michael Finus. 2020. Measures to enhance the effectiveness of international climate agreements: The case of border carbon adjustments (second revised version). *European Economic Review* 124: 103405. [CrossRef]
- Kirchner, Mathias, and Erwin Schmid. 2013. Integrated regional impact assessment of agricultural trade and domestic environmental policies. *Land Use Policy* 35: 359–78. [CrossRef]
- Kuhn, Thomas, Radomir Pestow, and Anja Zenker. 2019. Building Climate Coalitions on Preferential Free Trade Agreements. *Environmental and Resource Economics* 74: 539–69. [CrossRef]
- Larch, Mario, and Joschka Wanner. 2017. Carbon tariffs: An analysis of the trade, welfare, and emission effects. *Journal of International Economics* 109: 195–213. [CrossRef]
- Laurens, Noemie, Zachary Dove, Jean Frederic Morin, and Sikina Jinnah. 2019. NAFTA 2.0: The Greenest Trade Agreement Ever? *World Trade Review*, 1–19. [CrossRef]
- Leal-Arcas, Rafael. 2018. New Frontiers of International Economic Law: The Quest for Sustainable Development. *University of Pennsylvania Journal of International Law* 40: 83–133.
- Liao, Tsung-Sheng. 2017. Regional Trade Agreements as Laboratories for New Trade Disciplines to Tackle Climate Change: Why and How? *China and WTO Review* 3: 91–108. [CrossRef]
- Liddle, Brantley. 2017. Consumption-based accounting and the trade-carbon emissions nexus. *Energy Economics* 69: 71–78. [CrossRef]
- Low, Patrick, and Marina Murina. 2010. Managing cooperation on climate change: What can we learn from the WTO? *The Journal of International Trade and Economic Development* 19: 135–61. [CrossRef]
- Mathews, John. A. 2016. Global trade and promotion of cleantech industry: A post-Paris agenda. *Climate Policy* 17: 102–10. [CrossRef]
- Meyer, Timothy. 2017. Explaining energy disputes at the World Trade Organization. *International Environmental Agreements: Politics, Law and Economics* 17: 391–410. [CrossRef]
- Moher, David, Alessandro Liberati, Jennifer Tetzlaff, and Douglas G. Altman. 2009. The PRISMA Group Preferred Reporting Items for Systematic Reviews and Meta-Analyses: The PRISMA Statement. *PLoS Medicine* 6: e1000097. [CrossRef]
- Monkelbaan, Joachim. 2017. Using trade for achieving the SDGs: The example of the environmental goods agreement. *Journal of World Trade* 51: 575–604.
- Montagna, Catia, Avanti Nisha Pinto, and Nikolaos Vlassis. 2020. Welfare and Trade Effects of International Environmental Agreements. *Environmental and Resource Economics* 76: 331–45. [CrossRef]
- Morin, Jean-Frédéric, and Sikina Jinnah. 2018. The untapped potential of preferential trade agreements for climate governance. *Environmental Politics* 27: 541–65. [CrossRef]
- Morin, Jean-Frédéric, Andreas Dür, and Lisa Lechner. 2018. Mapping the Trade and Environment Nexus: Insights from a New Data Set. *Global Environmental Politics* 18: 122–39. [CrossRef]
- Nemati, Mehdi, Wuyang Hu, and Michael Reed. 2019. Are free trade agreements good for the environment? A panel data analysis. *Review of Development Economics* 23: 435–53. [CrossRef]
- Nordhaus, William. 2015. Climate Clubs: Overcoming Free-riding in International Climate Policy. *American Economic Review* 105: 1339–70. [CrossRef]
- OECD. 2020. Developments Matter: Carbon Border Adjustment: A Powerful Tool if Paired with a Just Energy Transition. Available online: <https://oecd-development-matters.org/2020/10/27/carbon-border-adjustment-a-powerful-tool-if-paired-with-a-just-energy-transition/> (accessed on 8 March 2021).

- Sauquet, Alexandre. 2012. Exploring the nature of inter-country interactions in the process of ratifying international environmental agreements: The case of the Kyoto Protocol. *Public Choice* 159: 141–58. [CrossRef]
- Scopus. 2020. Search String: TITLE-ABS-KEY (Trade Agreement and Climate Change). Available online: <https://www.scopus.com/results/results.uri?sort=plf-f&src=s&est1=%22trade+agreement%22+AND+%22climate+change%22&nlo=&nlr=&nls=&sid=7210ee606ec581ec086b9f7ec384ef26&sot=b&sd=cl&cluster=scosubjabbr%2c%22ECON%22%2ct%2bscolang%2c%22English%22%2ct%2c%22French%22%2ct%2b%2bscopubyr%2c%222020%22%2ct%2c%222019%22%2ct%2c%222018%22%2ct%2c%222017%22%2ct%2c%222016%22%2ct%2c%222015%22%2ct%2c%222014%22%2ct%2c%222013%22%2ct%2c%222011%22%2ct%2c%222010%22%2ct%2bscosubtype%2c%222ar%22%2ct&sl=53&ts=TITLE-ABS-KEY%28%22trade+agreement%22+AND+%22climate+change%22%29&origin=resultslist&z=leftSideBar&editSaveSearch=&txGid=6cb629803a9c511150d9da7ea4105194> (accessed on 21 September 2020).
- Shapiro, Joseph. S. 2020. *The Environmental Bias of Trade Policy*. Working Paper 26845. Cambridge: National Bureau of Economic Research.
- Solomon, Nathaniel, and Syed Abdul Rehman Khan. 2020. The Nexus between Urbanization, Renewable Energy, Trade, and Ecological Footprint in ASEAN Countries. *Journal of Cleaner Production* 272: 122709.
- United Nations Environment Programme. 2020. Emissions Gap Report 2020. Nairobi. ISBN 978-92-807-3812-4. Available online: <https://www.unep.org/emissions-gap-report-2020> (accessed on 15 April 2021).
- Web of Science. 2020. WoS. Available online: https://apps.webofknowledge.com/Search.do?product=WOS&SID=E4VR5ePRTCi2jfsB9PI&search_mode=GeneralSearch&prID=2ac97454-9aa2-4ad2-91a2-5d1155eaa5d4 (accessed on 21 September 2020).
- WTO. 2020. Trade and Environment. Available online: https://www.wto.org/english/tratop_e/envir_e/envir_e.htm (accessed on 15 April 2021).
- WTO. 2021a. Climate Change and the Potential Relevance of WTO Rules. Available online: https://www.wto.org/english/tratop_e/envir_e/climate_measures_e.htm (accessed on 16 April 2021).
- WTO. 2021b. Regional Trade Agreements. Available online: https://www.wto.org/english/tratop_e/region_e/region_e.htm (accessed on 16 April 2021).
- WTO. 2021c. Preferential Trade Agreements, Trade Creation and Trade Diversion. Available online: https://www.wto.org/english/res_e/publications_e/wtr11_forum_e/wtr11_12july11_bis_e.htm (accessed on 17 April 2021).
- WTO. 2021d. The General Agreement on Trade in Services (GATS): Objectives, Coverage and Disciplines. Available online: https://www.wto.org/english/tratop_e/serv_e/gatsqa_e.htm (accessed on 15 April 2021).
- Yasmeen, Rizwana, Yunong Li, Muhammad Hafeez, and Haseeb Ahmad. 2018. The trade-environment nexus in light of governance: A global potential. *Environmental Science and Pollution Research* 25: 34360–79. [CrossRef] [PubMed]
- Young, Margaret A. 2017. Energy transitions and trade law: Lessons from the reform of fisheries subsidies. *International Environmental Agreements* 17: 371–90. [CrossRef]
- Yu, Tun-Hsiang, Man-Keun Kim, and Seong-Hoon Cho. 2011. Does Trade Liberalization Induce More Greenhouse Gas Emissions? The Case of Mexico and the United States Under NAFTA. *American Journal of Agricultural Economics* 93: 545–52. [CrossRef]
- Yunfeng, Yan, and Yang Laike. 2010. China’s foreign trade and climate change: A case study of CO2 emissions. *Energy Policy* 38: 350–56. [CrossRef]

Commentary

Revisiting the Environmental Kuznets Curve: The Spatial Interaction between Economy and Territory

Enrico Maria Mosconi ¹, Andrea Colantoni ², Filippo Gambella ³, Eva Cudlinová ⁴,
Luca Salvati ^{5,*} and Jesús Rodrigo-Comino ^{6,7}

¹ Department of Economics, Engineering, Society and Business, University of Tuscia, Via del Paradiso 47, I-01100 Viterbo, Italy; enrico.mosconi@unitus.it

² Department of Agricultural and Forest Science, University of Tuscia, Via S. Camillo de Lellis snc, I-01100 Viterbo, Italy; colantoni@unitus.it

³ Department of Agricultural Science, University of Sassari, Viale Italia 39, I-07100 Sassari, Italy; gambella@uniss.it

⁴ Department of Regional Management, Faculty of Economics, University of South Bohemia in České Budějovice, 13 CZ-37005 Studentská, Czech Republic; evacu@centrum.cz

⁵ Department of Economics and Law, University of Macerata, Via Armadori 43, I-62100 Macerata, Italy

⁶ Physical Geography, Trier University, 54286 Trier, Germany; jesus.rodrigo@uv.es

⁷ Soil Erosion and Degradation Research Group, Department of Geography, University of Valencia, 46010 Valencia, Spain

* Correspondence: luca.salvati@unimc.it; Tel.: +39-380-72-89-966

Received: 17 July 2020; Accepted: 2 September 2020; Published: 14 September 2020

Abstract: A complex interplay of socio-ecological drivers of change exists at the different spatiotemporal scales affecting environmental degradation. This is a key issue worldwide and needs to be understood to develop efficient management solutions. One of the most applied theories in the regional analysis is the U-shaped relationship between environmental degradation and the level of income in a given economic system or Environmental Kuznets Curve (EKC). Specifically, the EKC hypothesis underlines the (potentially positive) role of formal responses to environmental degradation grounded on government policies that are usually more ambitious in wealthier economic systems. However, there is a lack of knowledge on the role of space in EKC, arguing that spatial variability in the environment–income relationship may indicate additional targets for integrated socio–environmental policies. We hypothesize that a spatially differentiated response to environmental degradation could better adapt to differentiated local contexts. Therefore, to achieve this goal, we present a multi-scale investigation of degradation processes at the local level, providing a refined knowledge of the environment–economy linkages considering more traditional, cross-country and cross-region exercises. Our results demonstrated that—together with temporal, sectoral, and institutional aspects—space and, consequently, the related analysis’ spatial scales, are significant dimensions in ecological economics, whose investigation requires improvements in data collection and dedicated statistical approaches.

Keywords: space; scale; land degradation; externalities; indicators; Italy

JEL Classification: Q5; R10; R14

1. Introduction

Social inequality, economic polarization, and territorial disparities represent a challenge in sustainable development, with direct (and indirect) environmental impacts (Boyce 1994; Barrett and Graddy 2000; Heerink et al. 2001). Environmental degradation has been observed in both emerging economies and wealthier countries and exerts an increasing impact on natural ecosystem

functioning and services (Sannigrahi et al. 2020; Sannigrahi et al. 2019). Several countries have shown accelerated rates of economic growth over the last decades; however, a sustained expansion seems to be no longer replicable under business-as-usual socio-ecological contexts (Fingleton 2016). It was, therefore, questioned whether a persistent growth—under policy inaction—is a sufficient condition to contain the pressure of human activities on the environment (Kahuthu 2006). Nowadays, we are assisting in a progressive ‘globalization’ of ecological degradation issues, while missing the socio-environmental role of both ‘regional’ and ‘local’ dimensions contributing to such processes (Briassoulis 2005). This would reflect the multifaceted interactions among economic dynamics, local communities and the ecological systems experiencing increased human disturbances (Franceschi and Kahn 2003; Dasgupta et al. 2006). Specific or combined biophysical and socio-economic drivers can cause environmental degradation affecting advanced and emerging economies with different intensity and severity (Cavlovic et al. 2000). Therefore, a refined understanding of the most significant factors fuelling economic growth and environmental measures is key to developing a more effective and coordinated response to ecosystem degradation (List and Gallet 1999) and achieving land degradation neutrality (Akhtar-Schuster et al. 2017). While countries have shown marked growth rates over the last century, a continued economic expansion—without policy intervention—is no longer regarded as a sufficient condition to contain human impacts (Agras and Chapman 1999). In such contexts, Spangenberg (Spangenberg 2001) outlined the importance of negative environmental externalities of the economic systems.

As a consequence, theoretical frameworks and quantitative approaches assessing convergence (or divergence) between economic growth and ecosystem degradation have been developed (Mukherjee and Kathuria 2006). In this regard, the Environmental Kuznets Curve (EKC) hypothesizing the existence of a non-linear, inverted U-shaped relationship between ecosystem degradation and a country’s income, has attracted increasing interest among scholars, policy-makers, and stakeholders (Caviglia-Harris et al. 2009). This hypothesis assumes the (supposedly beneficial) indirect role of rising income in maintaining ecosystem functions (Dasgupta et al. 2006). This assumption has contributed to broaden positive and normative debates on the environment–economy relationship while receiving criticism (Smulders 1999). However, the importance of the ‘spatial’ dimension in EKC research, as opposed to other relevant dimensions investigated in earlier studies (e.g., time, economic specialization, governance form, socio-cultural background), was usually missed. A renewed debate about which role (i) space and (ii) spatial scales play in the Environmental Kuznets Curve is still pending.

Suggesting a multi-scale analysis of degradation processes with high resolution and large spatial coverage (e.g., at local administrative–ecological territorial units) would allow a refined understanding of the largely differentiated environment–economy relationships over space (Auffhammer and Carson 2008). The spatial variability in the environment–economy relationship was assumed to reflect a locally specific role of income, wealth, and other socio-economic characteristics with differentiated linkages depending on the background context (Dinda 2004). Multi-scale investigations of the environment–economy dynamics oriented toward the EKC assumption may outline additional targets for integrated socio-ecological policies, with respect to more traditional, cross-country exercises (Stern 2004). Rupasingha et al. (Rupasingha et al. 2004) analyzed the relationship between per-capita income and toxic pollutants across 3029 continental United States counties, the most detailed spatial level for which used data can be found, and introduced refinements to address many of the worrisome aspects of the economy–environment relation. By demonstrating the awareness of most aspects highlighted here and related to the lack of information about this topic, a novel interpretation of the role of ‘space’ was proposed by estimating a spatial-lag statistical model (Rupasingha et al. 2004) and discussing the possible ‘scale mismatch’ among data used in environmental research.

Anselin (Anselin 2001a, 2001b) stated that environmental characteristics are often derived from physical measurements that result from an underlying spatial sampling design, and neither economic nor physical data collections necessarily match the spatial scale of the phenomenon under study. Reflecting non-stationary and spatially heterogeneous environmental, social and economic processes

interacting at multiple geographical scales, these (local-based) relationships require specific policy approaches with responses modulated at different (administrative) spatial domains. Being considered a sort of early warning predictor for intensity and severity of ecological degradation, local response to differentiated environmental–economy relationships should be flexible enough to adapt to transforming socio-economic contexts. However, a research gap still exists when linking (individual) processes of ecological degradation varying largely over space and the local background context in light of the EKC hypothesis (Salvati and Carlucci 2010). Substantive and methodological issues (with both positive and normative implications) remain at the base of this relationship (Salvati 2016): examples include the most appropriate size of spatial units to study the interactions between each process (e.g., environmental degradation and economic development).

By discussing the importance of a better understanding of local relationships between environment and income, the present commentary aims at (i) introducing some operational definitions of the Environmental Kuznets Curve; (ii) illustrating the main strengths and weaknesses of the EKC assumption; (iii) broadening the debate on the EKC through a specific focus on spatial and scaling issues; and (iv) evidencing the take-home message of this contribution, proposing a refined understanding of the spatially differentiated environment–economy nexus applied to a specific case study. By focusing on the importance of spatial explicit local approaches to EKC (Salvati and Zitti 2005), this paper (i) highlights the role of Geographically Weighted Regression (GWR) with an empirical application to a poorly studied issue (i.e., desertification risk), and (ii) evidences the importance of the appropriate spatial scale for analysis of environment–income relationships, suggesting a move beyond traditional variables and territorial domains (mainly of administrative nature). As in the empirical exercise illustrated in Chapter 4, the use of homogeneous districts with economic relevance (and widely used for territorial–environmental analysis) may stimulate a more intense debate on the appropriate unit for analysis of integrated socio-environmental phenomena.

2. Getting Inside the Environmental Kuznets Curve: Empirics and Criticism

The EKC hypothesis was formulated to disentangle the global environment–economy nexus from a developmental point of view (Dasgupta et al. 2002; Cole 2007; Galeotti 2007). Some contributions have included the EKC assumption in more formalized theoretical models, stemming from empirical findings (Andreoni and Levinson 2001; Hill and Magnani 2002; Bruvoll et al. 2003). The stylized facts emerging from theoretical and empirical analysis identified an ‘inverted-U’ relationship between ecosystem degradation and the level of the country’s income (Dinda 2004; Jha and Murthy 2003). Consumers characterized by lower incomes, prefer unsustainable commodities resulting in the lack of ‘greening’ of industrial products and institutional policies (Maddison 2007). Assuming an accelerated wealth creation as a precondition for technological progress, the country’s income indirectly sustains a more effective response to environmental degradation (Magnani 2000, 2001; Bimonte 2002). The EKC assumption illustrates a dynamic environment–economy relationship focusing on long-term processes of change (Bimonte and Stabile 2017b). These processes are mainly based on differentiated development paths, which are typical of countries that have experienced sequential stages of growth over time. Earlier studies identified different channels through which economic growth could influence ecosystem functioning and ecological conditions at large, reflecting the structural change, transformations in production scale, and technological progress (Salvati and Carlucci 2010; Chelli and Rosti 2002; Rosti and Chelli 2009; Rosti et al. 2005). Assuming a positive (while indirect) relationship between the economic capital, local communities, and environmental endowments, structural changes used to depend on coexisting dynamics of technology (Ciommi et al. 2018; Lamonica and Chelli 2018; Lamonica et al. 2020). These are both supply-oriented and demand-oriented innovations resembling the effects of the three transmission channels defined above (Jaffe et al. 2005; Rosti and Chelli 2012; Gigliarano and Chelli 2016). EKC studies have focused on specific environmental degradation processes such as short- and long-term air pollution (Ansuategi 2003; Bruvoll and Medin 2003; Aldy 2016), deforestation (Barbier et al. 1991; Choumert et al. 2013) and clearcutting (Lantz 2002). Relatively little research dealt

with water pollution (Paudel et al. 2005), hazardous wastes (Berrens et al. 1997; Wang et al. 1998), or agricultural land abandonment (James 1999). An even more restricted number of studies addressed the relationship between aggregate indexes of environmental quality (or degradation), sustainable development and income levels (Zaim and Taskin 2000). Recent papers have also investigated the intrinsic relationship between income levels and (i) soil/landscape degradation, (ii) desertification risk, and (iii) urbanization-driven land consumption (Salvati et al. 2011; Bimonte and Stabile 2017a, 2019).

The environment–economy relationship was supposed to be linear (de-coupling hypothesis) or polynomial (re-linking hypothesis). In the former case, economic growth has beneficial effects on environmental quality over the whole range of incomes (Rasli et al. 2018). In the latter case, if economic growth shows beneficial effects on environmental quality at lower (or intermediate) income levels, a ‘re-linking’ process is expected at higher income levels (Chelleri et al. 2015). A country’s income used to be associated with improving environmental conditions at the lower and intermediate levels and more stable conditions at the higher ones (Galeotti et al. 2006). The third (or higher-order) polynomial relationships highlight a more complex socio-ecological response as income rises. EKC studies estimate a vector of coefficients, identifying the specific impact of individual drivers on a given environmental process over a sufficiently broad range of income levels (De Bruyn 1997). Reduced form equations incorporating a (more or less) articulated ensemble of additional (non-income) predictors have been used frequently. However, only a partial consensus has been reached on the final specification of generalized income–environment relationships (Ozturk et al. 2016). The most diffused approach was based on the intrinsic comparison of first, second and third (or even higher-order) polynomials, evaluating different specifications for statistical robustness and empirical coherence (Mukherjee and Kathuria 2006). However, linear or polynomial functions can be hardly regarded as fully realistic representations of the economy–environment nexus (Figure 1), which is traditionally complex and intrinsically multi-dimensional and multi-scalar (Maddison 2006). Some specifications were regarded as approximate and simplified representations of a more articulated reality, raising estimation problems and underlining peculiar socio-economic and ecological dimensions. While first-order equations collapse EKC to a basic ‘de-coupling’ assumption, quadratic specifications imply that environmental degradation will move towards a plus (or minus) infinity as income increases (Mazzanti et al. 2008). Then, the third (or higher level) polynomials lead to N-shaped rather than U-shaped relationships, opening new issues in the economy–environment relationship for policy-making purposes (Sobhee 2004). A vast set of different specifications have been estimated for both income alone and income with additional predictors and covariates, using multivariate analysis and (more or less) refined econometrics (Harbaugh et al. 2000) incorporating: (i) a linear income descriptor (representing a ‘de-coupling’ baseline); (ii) linear and squared income terms (representing the EKC most usual case); and, (iii) linear, squared, cubic (and, sometimes, even more complex) income terms (representing extensions of the U-shaped curve toward more articulated, N-shaped, relationships).

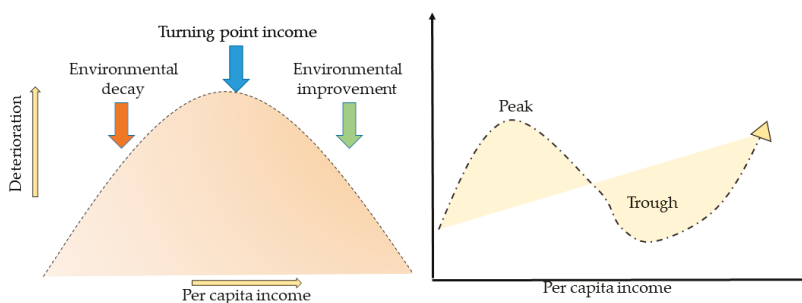

Figure 1. A classical inverted U-shaped Environmental Kuznets Curve (left) and a more complex N-shaped curve (right).

Additional predictors have been introduced and tested, mainly as linear (or polynomial) terms. While the final choice depends on data availability and research goals, there is no consensus on the type and number of predictors regarded as potential drivers of environmental degradation (Dinda 2004; Stern 1998). Due to this fact, seminal studies have used income as the unique predictor, interpreting the model's goodness-of-fit as a true indicator showing the net impact of economic growth on ecosystems (Galeotti 2007; Li et al. 2016). Heterogeneous drivers of environmental degradation generally include policy factors, socio-economic conditions and place-specific variables depending on the investigated spatial scale (Müller-Fürstenberger and Wagner 2007). However, some authors concluded that heterogeneity of place-specific predictors can prevent a full comparison of local-scale responses related to socio-environmental systems and income growth (Salvati 2014; Zaman et al. 2016; Zoundi 2017). At the same time, some authors have also criticized the EKC assumption (Heerink et al. 2001; Panayotou 1997; Chimeli 2007). We can summarize these concerns as follows: (i) if policy inaction is occurring, a persistent economic growth is not a sufficient condition to reduce human pressure on ecosystems (Ranjan and Shortle 2007); (ii) there is empirical evidence related to the validity of the EKC as a heterogeneous process depending on the environmental process tested (Arrow et al. 1995); and, (iii) this assumption reflects the shift from land-intensive to capital-intensive economic systems characterized by a growing capital availability and decreasing energy profits in the primary sector (Esposito et al. 2018), which could provide partial (and sometimes misleading) information on the total environmental impact. Other minor considerations are based on the assumption that there is no reason to hope that—with increasing wealth—any automatic decline in human pressure and, thus, environmental degradation would occur (Salvati et al. 2012). Only a mix of increasing wealth at both the macro- and micro-levels, a more generalized preference for 'greening' production, community awareness to environmental problems, and policy effectiveness may promote a higher level of ecosystem conservation (Salvati 2014; Heidkamp 2008; Rehman et al. 2012). Despite these above-mentioned criticisms, recent studies still consider EKC as a valid hypothesis to investigate the vast spectrum of the environment–economy relationships all over the world, feeding a normative debate (e.g., Kairis et al. 2015). By underlining the (potentially positive) role of the government policies—usually more ambitious in advanced countries (Barrett and Graddy 2000; Magnani 2000; de Bruyn et al. 1998)—these studies assume that the EKC directly reflects an 'induced policy response' able to outline how societies would demand more stringent environmental standards as income rises (Munasinghe 1999).

3. Broadening the Debate? Spatial Variability in the Relationship between Environment and Income

Especially in earlier studies investigating EKC at the global scale, similar economic rules have been frequently applied irrespective of the 'spatial' dimension (Zuindeau 2007). This assumption leads to a generalized application of standardized frameworks to explore spatial agglomeration, territorial specialization, and impacts of regionally differentiated productions on environmental quality at vastly different operational scales (Briassoulis 2005). Although a wealth of empirical studies have dealt with environmental economics in the most recent decades (e.g., Aldy 2016; Nijkamp 1999; Tan 2006), relatively few works integrated the specific knowledge from economic geography and regional science perspectives, addressing spatial issues in the environment–economy nexus (Agras and Chapman 1999; Alam et al. 2016). Coupled with a latent 'lack of interest' in spatially explicit approaches to EKC, the philosophical divergence between traditional (a-spatial) and more innovative (spatial) approaches resulted in a less effective understanding of spatial variability as a powerful driver of the environment–economy nexus (Bradford et al. 2000; Carson 2010; Bilgili et al. 2016).

Using simplified approaches, the causal linkage between regional economic performances and ecological degradation processes has been occasionally investigated, identifying the intrinsic drivers of change that interact at the same spatial scale only in a few cases (Salvati and Zitti 2009a). Although basic contributions to EKC have been grounded on cross-country data analysis for a long time, Ciriaci and Palma (Ciriaci and Palma 2008), likely for the first time, outlined how the EKC is fundamentally

a within-country story. Differentiating between-countries and within-countries dynamics, Vincent (Vincent 1997) argued how the EKC mostly reflects “the juxtaposition of a positive relationship between pollution and income in developing countries/regions with a fundamentally different, negative one in developed countries, not a single relationship that applies to both categories of countries”. Based on these premises, empirical studies have increasingly faced the challenging issue of spatial variability in the income–environment linkage at the regional scale (Smiraglia et al. 2016). Some of these studies have also criticized the quantitative analysis adopted in the earlier literature and have introduced (more or less) sophisticated techniques to estimate equation parameters, questioning the meaning and significance of the observed interactions (Kazemzadeh-Zow et al. 2017). Recent works have investigated the environment–economy nexus and the main determinants at disaggregated (e.g., sub-regional, district, local) spatial units considering representative cases, in connection with a more explicit analysis of the individual response and their environmental impact (Bajocco et al. 2012). Research devoted to the analysis of the income–environment relationship was mainly focused on (i) the role of place-specific factors of change; (ii) the interactions among them; and (iii) the importance of spatial effects.

Compared to the result of cross-country analysis, models incorporating multi-scale elementary data with large spatial coverage from homogeneous small areas to entire ecological regions provide a reliable set of statistical units possible delineating multiple economic–environment behaviors (Deacon and Norman 2006; Awaworyi Churchill et al. 2018). Although limited data variability is an intrinsic feature of such applications, the relevancy for policy-making purposes is generally high. Integrating cross-country and regional-differentiated analysis with district-based qualitative approaches and local inquiries provide the necessary base to a refined knowledge of robust, spatially explicit EKCs, irrespective of the environmental degradation process under investigation (Geoff and Juntti 2005). Assuming different environmental impacts of social change mediated by (more or less) adaptive local contexts, the role of space in the environment–economy relationship is intrinsically linked with socio-economic gradients that account for territorial disparities in the distribution of natural resources (Kim et al. 2018; Madden et al. 2019). More specifically, spatial disparities may reflect (i) economic specialization, (ii) the importance of specific production scales, and (iii) the role of decentralized multi-domain policies containing social inequalities and environmental degradation at vastly different intervention scales (Yamamoto 2008; Kaika and Zervas 2013b; Esposito et al. 2016).

Empirical evidence suggests that environmental externalities play differentiated roles at the country, regional and local scales. Consequently, the sub-regional scale is assumed as a particularly appropriate spatial level to delineate the different forms of the human–environment system, in their past development and in their capacity to suggest new directions of policy (Kairis et al. 2013). The structure of production systems and the interaction between environmental drivers and local communities suggest a more comprehensive analysis of the integrated policy response, distinguishing actions carried out by central governments, regional institutions, and local authorities (Brenner 2003). In this regard, verifying a spatially explicit environment–economy relationship at the different operational scales contributes to a refined understanding of the specific impact of any policy strategy within a range of different ‘macro’ (cross-country or cross-region) and ‘micro’ (individual actor, local community, cross-district) dimensions (Destek and Sarkodie 2019; Destek et al. 2018; Expósito et al. 2019). This rationale allows an in-depth investigation of the cumulative (or even adverse-to-income) effects of additional factors observed at the decentralized governance levels (Li et al. 2016; Lin et al. 2016; Gill et al. 2017; Luzzati et al. 2018).

4. Understanding the Spatially Differentiated Environment–Economy Nexus: The Case of Desertification Risk in Italy

4.1. Theoretical Framework

A better understanding of the spatial variability related to the economy–environment relationship contributes to the design of more effective decentralized policies for natural resource conservation and adapting to specific territorial contexts (Rasli et al. 2018). The empirical analysis of local relationships

between income and environment should clarify the impact of different institutional, operational, temporal and spatial scales, progressively moving from centralized levels (e.g., countries, administrative regions) to decentralized interactions involving local communities (e.g., prefectures, local labor systems, agricultural and industrial districts, rural areas, homogeneous municipalities and communes). The scale range adopted in spatially explicit EKC exercises should, therefore, consider economic- and policy-relevant analysis' units suitable to classify territorial units into homogeneous aggregates, considering the latent interaction between e.g., landscape and local communities (North 2005).

Intended as policy-relevant spatial units, use of administrative districts, municipalities, or local communities allows a comprehensive investigation of the role of 'decentralized' socio-economic contexts (Recanatani et al. 2016). In this regard, peculiar territorial characteristics and specific interactions with the environment can be completely ignored when adopting classical, 'centralized' EKC (or similar) approaches (Marston et al. 2005). Homogeneous labor districts, municipalities and local communes represent a suitable spatial domain to match socio-economic information (e.g., income, value-added, production and productivity by economic sector, labor market indicators) with relevant environmental indicators estimated from official statistics (Dumanski et al. 1998). Addressing issues of spatial comparability when combining ecological variables and socio-economic indicators is increasingly required (Delfanti et al. 2016). They are usually calculated, expressed and mapped at vastly different spatial scales and using distinctive geographical domains of aggregation (Incerti et al. 2007). These usually include eco-regions or other spatial partitions with a clear ecosystem meaning and rationale for ecological variables as well as administrative units/boundaries for socio-economic factors. In this context, computational issues such as the Modifiable Area Unit Problem, typical of the ecological analysis of socio-economic dynamics based on indicators aggregated on defined (administrative) spatial scales, can be mitigated. Furthermore, geospatial techniques regionalizing variables over homogeneous lattices would seem appropriate to contain the analysis' bias resulting from such an issue (Bajocco et al. 2011).

Based on these premises, spatially explicit methodologies can be adopted to identify local-based income–environment relationships using more complex analysis' strategies (Salvati and Zitti 2008). Spatial econometrics could provide a wealth of statistical techniques suitable to investigate this issue (Xie et al. 2019). However, relatively few techniques may identify the specificity of local-scale relationships starting from global income–environment relationships (Balado-Naves et al. 2018). The Geographically Weighted Regression (GWR) (Fotheringham et al. 2002) is a possible solution controlling for spatial structures that characterize the dependent variable (environment) and predictor(s) (income and, eventually, additional variables). It allows the estimation of a local regression model for each spatial unit in a given area. Being extensively used in a broad number of applications and disciplinary fields, the GWR approach is an appropriate methodology accounting for spatial dependence and heterogeneity (Rontos et al. 2016). Adopting various functions (including Kernel and other flexible spline approaches) to calculate weights for the estimation of local regression models, the methodological framework underlying GWR is similar to that of a traditional regression model. However, contrary to a spatially implicit ordinary least square regression (with location invariant regression coefficients), the specification of a basic GWR model for each location $s = 1, \dots, n$, is:

$$Y(s) = X(s)B(s) + e(s) \quad (1)$$

where $Y(s)$ is the dependent variable at location s , $X(s)$ represents the predictor at location s , $B(s)$ means the column vector of regression coefficients at location s , and $e(s)$ acts as the random error at location s . Hence, regression parameters estimated at each location by weighted least squares are spatially explicit. This implies that each coefficient in the model is a function of s , a point within the investigated geographical space. As a result, GWR gives rise to a distribution of local estimated parameters. The weighting scheme is expressed as a function (e.g., bi-square nearest neighbor kernel function, one of the most commonly used specifications) that places more weight on the observations closer to the location s (Salvati and Serra 2016). Coefficients of determination (R^2) and error values are estimated at the local

scale, providing indirect indications about stability over time, internal coherence and reliability of the GWR model (Ali et al. 2016). Limitations regarding the use of GWR only arise with the interpretation of extreme regression coefficients, or when drawing conclusions based on a reduced number of sample observations (Kaika and Zervas 2013a).

4.2. Empirical Approach

Desertification risk is considered a particularly important issue in the political agenda for the 21st century as the leading process of land resource depletion (Recanatani et al. 2016). Defined as a long-term decline in ecosystem functions and productivity, the land exposed to degradation increased worldwide, being particularly severe in Africa, Southern Asia, and Latin America, and becoming progressively more intense in wealthier economies in North America, Australia, and Europe (Delfanti et al. 2016). Thanks to climate change and growing human pressure, more than half of Mediterranean European land is sensitive to desertification (Kairis et al. 2015). Desertification risk is regarded as a composite process depending on biophysical, cultural, and institutional drivers acting together, with negative effects on food security and quality of life (Kairis et al. 2013). The incompleteness of scientific knowledge on the local relationship between desertification risk and economic performances may depend on the fact that social sciences have sometimes underestimated the significance of such issues, missing the importance of multi-scale assessment frameworks (Bajocco et al. 2011, 2012; Salvati et al. 2016).

As a paradigmatic example of the importance of local contexts in the analysis of environment–income dynamics, the relationship between a composite index of desertification risk and per-capita value-added produced at the local scale was modelled using a Geographically Weighted Regression in 686 economically homogeneous districts before the 2007 economic crisis in Italy. This country represents an advanced economy in Mediterranean Europe with significant socio-economic disparities and vast areas currently (or potentially) affected by desertification risk (Geoff and Juntti 2005). Therefore, desertification risk was assessed here based on the Environmentally Sensitive Area Index (the so-called ESAI), a comprehensive methodology used widely for evaluation of local-scale processes of land degradation (Kim et al. 2018; Madden et al. 2019; Yamamoto 2008). This methodology is composed of 14 basic variables assessing climate, soil, vegetation and land-use quality as proxies of land degradation processes (see below) as concluded by other studies (Bajocco et al. 2012; Karamesouti et al. 2015; Kosmas et al. 2016).

In the present study, per-capita value added was assumed as a reliable indicator of local competitiveness and economic performances of a given spatial unit, such as a local district (Ferrara et al. 2016). For the first time in Italy, and likely in Europe, official statistics of per-capita value added were provisionally released by the Italian National Statistical Institute (ISTAT) at the district level (local labor systems), providing a unique opportunity to test for the local impact of average income levels on a relevant process of environmental degradation. Release of official statistics of value-added and incomes at the district level was considered experimental and covered only a few years at the beginning of the 2000s (Salvati and Carlucci 2010). We used a Geographically Weighted Regression to provide local regression estimates of the impact of per-capita value-added on the level of desertification risk in Italy, giving an adjusted R^2 value for the global model as well as a set of local R^2 , slope coefficients, intercepts and standardized residuals for each local labor system at the most recent study year (2005) with a complete estimation of per-capita income at the same spatial level. These conditions can be assumed as representative of economic expansion with moderate/low rates of growth, common to several Mediterranean countries (Salvati 2016).

4.3. Estimating Desertification Risk in Italy

The ESAI framework defines different levels of desertification risk as a combination of possibly unsustainable land management together with a particular set of environmental factors including poor soil/vegetation and dry climate (Salvati et al. 2016). The elementary variables used to locally estimate the level of desertification risk in Italy refer to the ESAI framework being grouped in four

dimensions of environmental quality: climate, soil, vegetation/land use, and human pressure/land management (Delfanti et al. 2016). The most accurate, detailed and updated layers currently available in Italy were used at a basic resolution of 1:25,000, which is suitable for a local-level assessment of desertification risk (Recanatesi et al. 2016). The reference year of all elaborations is 2005. Following the ESAI model, the following variables were adopted to estimate climate quality: average annual rainfall rate, aridity index, and aspect (Salvati et al. 2012). Mean annual rainfall and aridity were derived from a national climate database regionalizing elementary data derived from nearly 3000 meteorological stations distributed all over Italy and functioning since 1951 (Scarascia et al. 2006). Aridity index was calculated according to UNEP (United Nations Environment Programme) formulation, considering the ratio of total precipitation and reference evapotranspiration every year. The aspect was obtained from a 20 m Digital Terrain Model of Italy provided by the Italian Minister of Environmental Protection (Rome).

Soil data were derived from: (i) the European Soil Database (Joint Research Center, JRC) at a 1 km² pixel resolution, integrated with national information sources (an Italian database of soil characteristics ('Map of the water capacity in agricultural soils') generated by the Ministry of Agriculture and based on nearly 18,000 soil samples; (ii) thematic sources including Eco-pedological and Geological maps of Italy, obtained from the Joint Research Centre and the Italian Geological Service, and a map of land systems produced by the National Centre of Soil Cartography (Florence). These datasets were assumed as the most homogeneous and spatially detailed soil information for Italy, being available at 1:250,000 scale (Bajocco et al. 2011). According to the standard ESAI model, we considered the following variables: soil depth and texture, slope, and the nature of the parent material. These variables were assumed as proxies of other soil quality indicators, e.g., organic matter content, resistance or tendency to compact (Kairis et al. 2013). The specific contribution of land cover/land-use on desertification risk was assessed through four variables: vegetation cover, fire risk, the protection offered by vegetation against soil erosion, and the degree of resistance to drought provided by vegetation (Bajocco et al. 2012). Such indicators were obtained from the elaboration of a CORINE (Coordination of Information on the Environment) land cover map (2006) provided by the European Environment Agency (EEA). The four variables described below were calculated using a weighting system (ranging from one to two and derived from (Salvati et al. 2016)) that classifies the observed land cover class according to the level of desertification risk.

Anthropogenic pressure and land management quality were finally evaluated as the result of population dynamics and landscape transformations (e.g., urbanization, agricultural intensification). Population density and annual growth rate were used as summary indicators of human pressure (Salvati et al. 2012). The population density was measured at municipal scale in 2005 based on the annual Population Register held by the Italian National Institute of Statistics (ISTAT). Population increase (or decrease) was determined as the annual population change (%) observed at the municipal scale between 2002 and 2005. An indicator of land intensity was finally calculated applying a weighting system (ranging from one to two) that classifies the observed CORINE class according to the intensity of use and potential level of desertification risk (Recanatesi et al. 2016). Based on the estimated degree of correlation between each characteristic dimension and desertification risk, the scoring system suggested by Salvati et al. (Salvati et al. 2016)—ranging between one (the lowest contribution to desertification risk) and two (the highest contribution to desertification risk)—was applied to each variable in the ESAI. Quality indicators (climate: CQI, soil: SQI, vegetation/land-use: VQI, human pressure/land management: MQI) were estimated as the geometric mean of the different scores assigned to each input variable. Ranging between one (the lowest desertification risk) and two (the highest desertification risk), the ESAI was then estimated at each spatial unit as the geometric mean of the four quality indicators as follows (Salvati and Zitti 2005):

$$ESAI = (SQI * CQI * VQI * MQI)^{1/4} \quad (2)$$

4.4. Applying the Geographically Weighted Regression to Assess Desertification Risk in Italy

Results of the statistical analysis are illustrated in Figure 2. Goodness-of-fit of the global model was particularly high (adjusted $R^2 = 0.70$), although local R^2 coefficients, slope coefficients and intercepts varied largely over space. The highest R^2 coefficients were observed in a large part of Northern Italy coinciding with the Po plain, an area characterized by high human pressure and classified as potentially affected by desertification risk. The specific impact of per-capita value added was highly positive in the Po Plain and along the Adriatic Sea coast in central Italy, as the R^2 coefficient clearly illustrated (Figure 2, upper left). These districts were characterized by a locally high anthropogenic pressure (reflected in e.g., population concentration, landscape simplification, and crop intensification). Increasing incomes in such contexts correspond to a higher level of desertification risk, as slope coefficients systematically higher than one indicate (Figure 2, upper right). However, wealthier districts in the Alpine and Pre-Alpine regions registered a negative income–environment linkage (negative slope coefficients), being often reflected in a lower level of desertification risk.

Conversely, the specific impact of economic growth was often negative in both internal and coastal districts of southern Italy, a region classified at risk of desertification in the National Action Plan to Combat Desertification. Negative slope coefficients were especially observed in the Abruzzo, Campania, Molise and Apulia regions, and more sparsely in Calabria, Sicily and Sardinia. In these areas—mostly rural districts with traditional agriculture and low population density—increasing incomes do not have a negative impact on desertification risk, because of moderate human pressure. Residuals’ estimates complete the model’s results, indicating spatial randomness of statistical errors. The empirical association between district slope coefficient (y) derived from GWR (Figure 2, upper right map) and per-capita value added (x) was best fitted using a second-order polynomial equation ($y = -1e^{-9}x^2 + 8e^{-5}x - 0.546$, $R^2 = 0.30$, $n = 686$ districts). The threshold for the positive (or negative) impact of income on desertification risk was estimated at around 30,000 euros per head. Income levels had a positive impact on desertification risk in districts producing a value-added above this threshold. In economic districts with a per-capita value-added below this threshold, increasing income levels were associated, on average, with increasing levels of desertification risk.

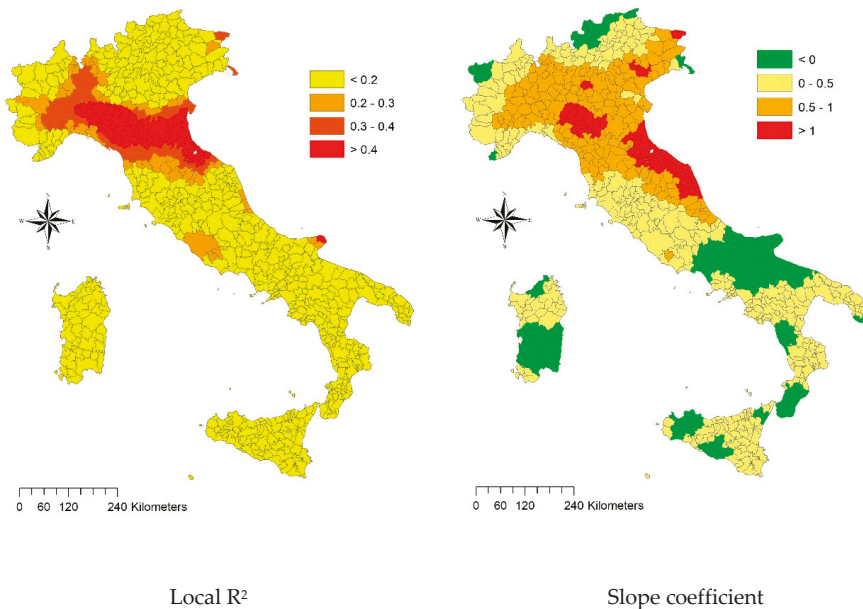

Figure 2. Cont.

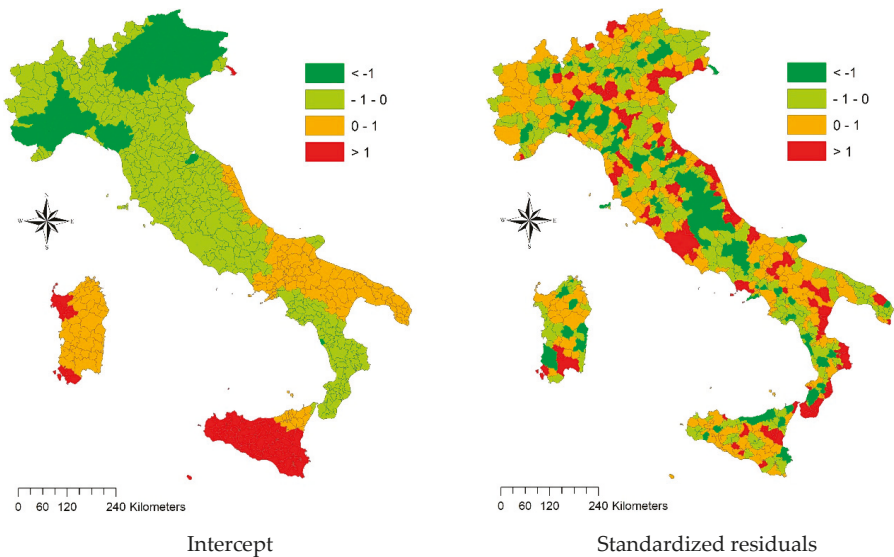

Figure 2. Results of a Geographically Weighted Regression for the level of desertification risk (dependent variable) and per-capita value added (predictor) at the local district scale in Italy (2005).

5. Discussion

This commentary provides a literature review of past and recent studies on the Environmental Kuznets Curve and a local analysis of the relationship between a specific environmental process and economic development at the district scale in Italy. Based on a local regression approach, the results of this quantitative exercise can be considered when developing more effective policies aimed at mitigating environmental degradation in Mediterranean-type ecosystems (Salvati et al. 2012). The empirical findings of the analysis suggest that a significant correlation exists between desertification risk and the level of economic growth in the Italian local districts (Salvati and Carlucci 2010), being differentiated largely over space. More specifically, results of the GWR suggest that the relationship between income and desertification risk follows a U-shaped form compatible with the Environmental Kuznets Curve (Salvati and Zitti 2008). As expected from the relatively low human pressure, desertification risk was moderate in economically disadvantaged local districts (Recanatesi et al. 2016). However, growing incomes—likely determining a rising human pressure—were associated with higher levels of desertification risk, promoting e.g., negative externalities of economic activity. Conversely, in the wealthiest local districts, growing incomes were associated with lower levels of desertification risk, stimulating positive externalities of e.g., environmental protection. This general trend can be further decomposed at the local scale, evidencing spatial peculiarities going beyond the traditional administrative boundaries (e.g., regions, prefectures) adopted in earlier studies (Delfanti et al. 2016), as well as in official environmental reporting and statutory policy acts (e.g., the National Action Plan to combat desertification). These sources give general policy indications for Italy and provide some specific suggestions for a regional strategy against desertification, while demising local interventions that may greatly benefit from the results of this study (Salvati et al. 2012).

Considering local outcomes of a Geographically Weighted Regression model (and, more specifically, local R^2 and slope coefficients), this example illustrates the advantages of a local-scale investigation of the environment–income relationship for policy impact analysis, evidencing the fine-grain geography of positive (or negative) externalities of increasing income levels. Giving room to a refined analysis of place-specific Kuznets curves, these findings reveal the importance of decentralized strategies of risk containment, accounting for partially differentiated—and mostly non-linear—impacts of local income

on desertification risk (Delfanti et al. 2016; Cecchini et al. 2019). At the same time, although potentially useful when making exploratory analysis, the EKC mechanism needs refinement when interpreting the inherent complexity of the human–environment interactions. Local-scale analyses contribute to such a deserving issue (Bajocco et al. 2012). While income is a significant variable determining the development stage of a region—having feedback effects on the environment through indirect mechanisms by e.g., increasing the demand for higher environmental quality—the process itself is assumed to be more complex as several other variables can take part in the same relationship (Salvati and Zitti 2005). However, assuming per-capita value-added as a proxy of the economic performances of a local district, with local regressions based on the income level as the unique predictor provides an honest estimation of the spatially varying extent and direction of the income–environment relationship (considering together the local R^2 and slope coefficients). Districts with high R^2 and a highly positive (or negative) slope coefficient are those where the income–environment relationship was more intense. Districts with moderate R^2 and a low slope coefficient delineate a less intense income–environment linkage, possibly shaped by territorial characteristics and peculiar social contexts. In both cases, these results inform policies that may specifically impact processes of change at a local scale, avoiding generalized approaches to mitigate land degradation. At the same time, the results of a local-scale analysis may confirm how integrated policy measures at different spatial scales represent a coherent response against the multiple factors contributing to desertification risk (Kairis et al. 2015).

The empirical exercise proposed in this commentary outlines the importance of fine-grained territorial data of the environment–economy relationship analyzed through spatially explicit local techniques (Scarascia et al. 2006). Lack of geo-referenced point data (or high-resolution, polygon or grid aggregate information), especially for key socio-economic variables, limits the applicability of spatially explicit analysis of local income–environment relationships. Even in advanced countries, relatively little (comparable) information on the environment–economy relationship is available at the different spatial levels (regions, districts, municipalities, ecological/agricultural units, and homogeneous domains of environmental interest/relevance). The reasons at the base of such a data shortage include (i) the difficult assessment of some environmental processes at the disaggregated spatial scales; (ii) the different importance of biophysical, social, economic, institutional, political, and cultural drivers, and (iii) non-linear and multivariate interactions among these drivers (Salvati and Carlucci 2010). An even more complex issue is the selection of an adequate temporal scale of investigation when deriving a theoretical framework for the environment–economy relationship (Incerti et al. 2007). This issue depends on the fact that environmental degradation processes do not follow linear dynamics, being instead linked to point or widespread sources of emissions and depending on different biophysical processes and/or interactions (Rodrigo-Comino et al. 2018; Cerdà et al. 2010).

The systematic collection of information, especially when it is based on field surveys and statistical sampling, is often carried out for merely administrative purposes (Salvati 2016). At the same time, official environmental reporting is based primarily on regionalized information collected at aggregate spatial units of administrative nature and relevance. These domains are unsuitable for analysis and interpretation of phenomena that do not directly follow the political boundaries of a state, a region or a prefecture. Remote sensing can overcome some constraints in the analysis of environmental processes, providing spatial information on regular geometry lattices, i.e., grids (Bajocco et al. 2012). However, only some specific processes of environmental degradation can be permanently monitored considering the outcome of satellite imagery elaboration alone (Bajocco et al. 2011). More frequently, remote sensing results require integration with ancillary (direct) field surveys, official statistics, and digital mapping to provide an appropriate evaluation of complex environmental degradation processes. Environmental statistics have, in turn, a less solid and prolonged tradition over time than those related to social and economic issues, improved for a long time through censuses, sample surveys and the use of strictly administrative sources (e.g., population and business registers).

Environmental surveys considering small sample sizes sometimes have estimation errors that do not allow a particularly reliable spatial analysis. The growing use of spatially explicit methodologies

and integrated management of geo-referenced databases (e.g., Geographic Information Systems), better integration with satellite imagery, and the increasing diffusion of geostatistical techniques, are elements that envisage a greater availability of quantitative information and reliable environmental measures (Salvati and Zitti 2009c). At the same time, further research efforts should be devoted to identifying ecologically relevant spatial units, proposing a new view of the environment–economy from a non-economic perspective (Salvati and Zitti 2009b). As many studies highlight, regional and local administrative units are often under-representative of complex environmental dynamics at the base of degradation processes, affecting the estimation of EKC (Esposito et al. 2018). These units should be designed to allow a comparative analysis of meaningful environmental indicators and integration with reliable socio-economic variables. Being grounded on criteria of ecological homogeneity, these domains are optimal to depict the impact of environmental policies at both regional and local levels of governance (Özokcu and Özdemir 2017). Based on these premises, the spatial variability of the environment–economy relationship characteristic of a given territorial context and the ecological process, can be interpreted as a key dimension in monitoring programs and policy strategies (Katircioğlu and Katircioğlu 2018). The intrinsic influence on the environment–economy relationships indicates costs and benefits when adopting different but spatially coordinated disaggregated analysis' levels.

6. Conclusions

Since the EKC is a rather simplistic assumption of the complex environment–economy relationships, the underlying mechanisms were mostly seen as statistically automatic and not causative. As clearly highlighted in the exercise proposed in this commentary, the value-added of the EKC hypothesis was to provide further insights into the decentralized environment–economy dynamics. While cross-country analysis may represent a fruitful research issue in ecological economics, moving to disaggregated analysis' scales and spatially explicit approaches is a strategy containing technical problems associated with the comparison of aggregated data from different countries. Reflecting endogenous dynamics of de-coupling (or re-linking) wealth and environmental quality, the increasing gap between low- and high-income areas suggests that the role of mitigation-oriented policies and their impact on ecosystems is differentiated across regions. As clarified in our empirical exercise, spatially explicit approaches to EKC—particularly useful in the analysis of the intrinsic environment–income relationship of diffused processes of ecological degradation require the use of refined elementary data and variables derived from official statistics, whose collection should move from strictly administrative domains to innovative territorial units based on homogeneous socio-economic criteria and with relevance for environmental assessment.

Italy represents an example of the possible increasing gap, fuelled by the income-driven dynamics emerging between lower and higher-income areas. The different role of mitigation-oriented policies and their impact on desertification risk in the northern and southern regions of the country can be extensively analyzed using our approach (Salvati and Zitti 2009b). In such a context, coordination of multi-scale (national, regional, local) and multi-target (economic, social, environmental) policies is expected to improve the effectiveness of strategies mitigating desertification risk (Briassoulis 2005). In this regard, focusing on locally-based EKC provides indications to inform place-specific policies under comparable socio-economic contexts and biophysical conditions. Intimate knowledge of the local relations between the economy and the environment makes it possible to translate centralized and generalized intervention strategies into the specificity of each regional context, mitigating degradation processes more effectively. A decentralized and locally based response to environmental degradation stimulates a more rapid adaptation to external shocks, enhancing the resilience capacity of local economic systems. While consensus on optimal indicators and methodologies for local EKC does not exist, different measures and approaches have different implications and interpretations. For instance, composite indexes should be preferred when assessing more complex environmental phenomena. Cross-scale integration of policy measures (e.g., environmental measures at the individual level, social measures at the municipal level, economic policies at regional or national levels) may represent a

coherent response to spatially differentiated drivers of change. In such a context, spatially coordinated multi-scale policies are expected to improve the effectiveness of mitigation and adaptation strategies to any process of environmental degradation in the light of sustainable development.

Author Contributions: Conceptualization, L.S. and A.C.; methodology, E.M.M. and J.R.-C.; investigation, F.G. and J.R.-C.; resources, E.M.M.; writing—original draft preparation, E.C. and L.S.; writing—review and editing, F.G., J.R.-C. and E.M.M.; visualization, A.C. and J.R.-C.; supervision, A.C. and J.R.-C.; project administration, E.C.; funding acquisition, F.G. All authors have read and agreed to the published version of the manuscript.

Funding: This research received no external funding.

Conflicts of Interest: The authors declare no conflict of interest.

References

- Agras, Jean, and Duane Chapman. 1999. A Dynamic Approach to the Environmental Kuznets Curve Hypothesis. *Ecological Economics* 28: 267–77. [\[CrossRef\]](#)
- Akhtar-Schuster, Mariam, Lindsay C. Stringer, Alexander Erlewein, Graciela Metternicht, Sara Minelli, Uriel Safriel, and Stefan Sommer. 2017. Unpacking the concept of land degradation neutrality and addressing its operation through the Rio Conventions. *Journal of Environmental Management* 195: 4–15. [\[CrossRef\]](#) [\[PubMed\]](#)
- Alam, Md. Mahmudul, Md. Wahid Murad, Abu Hanifa Md. Noman, and Ilhan Ozturk. 2016. Relationships among Carbon Emissions, Economic Growth, Energy Consumption and Population Growth: Testing Environmental Kuznets Curve Hypothesis for Brazil, China, India and Indonesia. *Ecological Indicators* 70: 466–79. [\[CrossRef\]](#)
- Aldy, J. E. 2016. An Environmental Kuznets Curve Analysis of U.S. State-Level Carbon Dioxide Emissions. *The Journal of Environment & Development* 14: 48–72. [\[CrossRef\]](#)
- Ali, Kamar, Mark D. Partridge, and M. Rose Olfert. 2016. Can Geographically Weighted Regressions Improve Regional Analysis and Policy Making? *International Regional Science Review* 30: 300–29. [\[CrossRef\]](#)
- Andreoni, James, and Arik Levinson. 2001. The Simple Analytics of the Environmental Kuznets Curve. *Journal of Public Economics* 18: 269–86. [\[CrossRef\]](#)
- Anselin, Luc. 2001a. Spatial Effects in Econometric Practice in Environmental and Resource Economics. *American Journal of Agricultural Economics* 83: 705–10. [\[CrossRef\]](#)
- Anselin, L. 2001b. Rao's score test in spatial econometrics. *Journal of Statistical Planning and Inference* 97: 113–39. [\[CrossRef\]](#)
- Ansuategi, Alberto. 2003. Economic Growth and Transboundary Pollution in Europe: An Empirical Analysis. *Environmental and Resource Economics* 26: 305–28. [\[CrossRef\]](#)
- Arrow, Kenneth, Bert Bolin, Robert Costanza, Partha Dasgupta, Carl Folke, C. S. Holling, Bengt-Owe Jansson, Simon Levin, Karl-Goran Maler, Charles Perrings, and et al. 1995. Economic Growth, Carrying Capacity, and the Environment. *Ecological Economics* 15: 91–95. [\[CrossRef\]](#)
- Auffhammer, Maximilian, and Richard T. Carson. 2008. Forecasting the Path of China's CO₂ Emissions Using Province-Level Information. *Journal of Environmental Economics and Management* 55: 229–47. [\[CrossRef\]](#)
- Awaworyi Churchill, Sefa, John Inekwe, Kris Ivanovski, and Russell Smyth. 2018. The Environmental Kuznets Curve in the OECD: 1870–2014. *Energy Economics* 75: 389–99. [\[CrossRef\]](#)
- Bajocco, Sofia, Luca Salvati, and Carlo Ricotta. 2011. Land Degradation versus Fire: A Spiral Process? *Progress in Physical Geography: Earth and Environment* 35: 3–18. [\[CrossRef\]](#)
- Bajocco, Sofia, Antonella De Angelis, and Luca Salvati. 2012. A Satellite-Based Green Index as a Proxy for Vegetation Cover Quality in a Mediterranean Region. *Ecological Indicators* 23: 578–87. [\[CrossRef\]](#)
- Balado-Naves, Roberto, José Francisco Baños-Pino, and Matías Mayor. 2018. Do Countries Influence Neighbouring Pollution? A Spatial Analysis of the EKC for CO₂ Emissions. *Energy Policy* 123: 266–79. [\[CrossRef\]](#)
- Barbier, Edward B., Joanne C. Burgess, and Anil Markandya. 1991. The Economics of Tropical Deforestation. *Ambio* 20: 55–58. [\[CrossRef\]](#)
- Barrett, Scott, and Kathryn Graddy. 2000. Freedom, Growth, and the Environment. *Environment and Development Economics* 5: 433–56. [\[CrossRef\]](#)
- Berrens, Robert P, Alok K Bohara, Kishore Gawande, and Pingo Wang. 1997. Testing the Inverted-U Hypothesis for US Hazardous Waste: An Application of the Generalized Gamma Model. *Economics Letters* 55: 435–40. [\[CrossRef\]](#)

- Bilgili, Faik, Emrah Koçak, and Ümit Bulut. 2016. The Dynamic Impact of Renewable Energy Consumption on CO₂ Emissions: A Revisited Environmental Kuznets Curve Approach. *Renewable and Sustainable Energy Reviews* 54: 838–45. [\[CrossRef\]](#)
- Bimonte, Salvatore. 2002. Information Access, Income Distribution, and the Environmental Kuznets Curve. *Ecological Economics* 41: 145–56. [\[CrossRef\]](#)
- Bimonte, Salvatore, and Arsenio Stabile. 2017a. Land Consumption and Income in Italy: A Case of Inverted EKC. *Ecological Economics* 131: 36–43. [\[CrossRef\]](#)
- Bimonte, Salvatore, and e Arsenio Stabile. 2017b. EKC and the Income Elasticity Hypothesis Land for Housing or Land for Future? *Ecological Indicators* 73: 800–8. [\[CrossRef\]](#)
- Bimonte, Salvatore, and Arsenio Stabile. 2019. The Effect of Growth and Corruption on Soil Sealing in Italy: A Regional Environmental Kuznets Curve Analysis. *Environmental and Resource Economics* 74: 1497–518. [\[CrossRef\]](#)
- Boyce, James K. 1994. Inequality as a Cause of Environmental Degradation. *Ecological Economics* 11: 169–78. [\[CrossRef\]](#)
- Bradford, David F, Rebecca Schlieckert, and Stephen H Shore. 2000. The Environmental Kuznets Curve: Exploring A Fresh Specification. Working Paper 8001. *Contributions to Economic Analysis & Policy* 4: 5. [\[CrossRef\]](#)
- Brenner, Neil. 2003. Metropolitan Institutional Reform and the Rescaling of State Space in Contemporary Western Europe. *European Urban and Regional Studies* 10: 297–324. [\[CrossRef\]](#)
- Briassoulis, H. 2005. Policy Integration for Complex Environmental Problems: The Example of Mediterranean Desertification. London: Routledge.
- Bruvoll, Annegrete, and Hege Medin. 2003. Factors behind the Environmental Kuznets Curve. A Decomposition of the Changes in Air Pollution. *Environmental and Resource Economics* 24: 27–48. [\[CrossRef\]](#)
- Bruvoll, Annegrete, Taran Fæhn, and Birger Strøm. 2003. Quantifying Central Hypotheses on Environmental Kuznets Curves for a Rich Economy: A Computable General Equilibrium Study. *Scottish Journal of Political Economy* 50: 149–73. [\[CrossRef\]](#)
- De Bruyn, Sander M. 1997. Explaining the Environmental Kuznets Curve: Structural Change and International Agreements in Reducing Sulphur Emissions. *Environment and Development Economics* 2: 485–503. [\[CrossRef\]](#)
- de Bruyn, S. M, J. C. J. M van den Bergh, and J. B Opschoor. 1998. Economic Growth and Emissions: Reconsidering the Empirical Basis of Environmental Kuznets Curves. *Ecological Economics* 25: 161–75. [\[CrossRef\]](#)
- Carson, Richard T. 2010. The Environmental Kuznets Curve: Seeking Empirical Regularity and Theoretical Structure. *Review of Environmental Economics and Policy* 4: 3–23. [\[CrossRef\]](#)
- Caviglia-Harris, Jill L., Dustin Chambers, and James R. Kahn. 2009. Taking the “U” out of Kuznets: A Comprehensive Analysis of the EKC and Environmental Degradation. *Ecological Economics* 68: 1149–59. [\[CrossRef\]](#)
- Cavlovic, Therese A., Kenneth H. Baker, Robert P. Berrens, and Kishore Gawande. 2000. A Meta-Analysis of Environmental Kuznets Curve Studies. *Agricultural and Resource Economics Review* 29: 1–11. [\[CrossRef\]](#)
- Cecchini, Massimo, Ilaria Zambon, Antonella Pontrandolfi, Rosario Turco, Andrea Colantoni, Anastasios Mavrakis, and Luca Salvati. 2019. Urban Sprawl and the ‘Olive’ Landscape: Sustainable Land Management for ‘Crisis’ Cities. *GeoJournal* 84: 237–55. [\[CrossRef\]](#)
- Cerdà, A., H. Lavee, A. Romero-Díaz, J. Hooke, and L. Montanarella. 2010. Preface: Soil erosion and degradation in mediterranean type ecosystems. *Land Degradation and Development* 21: 71–74. [\[CrossRef\]](#)
- Chelleri, L., T. Schuetze, and L. Salvati. 2015. Integrating Resilience with Urban Sustainability in Neglected Neighborhoods: Challenges and Opportunities of Transitioning to Decentralized Water Management in Mexico City. *Habitat International* 48: 122–30. [\[CrossRef\]](#)
- Chelli, Francesco, and Luisa Rosti. 2002. Age and gender differences in Italian workers’ mobility. *International Journal of Manpower* 23: 313–25. [\[CrossRef\]](#)
- Chimeli, Ariaster B. 2007. Growth and the Environment: Are We Looking at the Right Data? *Economics Letters* 96: 89–96. [\[CrossRef\]](#)
- Choumert, Johanna, Pascale Combes Motel, and Hervé K. Dakpo. 2013. Is the Environmental Kuznets Curve for Deforestation a Threatened Theory? A Meta-Analysis of the Literature. *Ecological Economics* 90: 19–28. [\[CrossRef\]](#)

- Ciommi, Mariateresa, Francesco M. Chelli, Margherita Carlucci, and Luca Salvati. 2018. Urban Growth and Demographic Dynamics in Southern Europe: Toward a New Statistical Approach to Regional Science. *Sustainability* 10: 2765. [CrossRef]
- Ciriaci, Daria, and Daniela Palma. 2008. The Role of Knowledge-Based Supply Specialisation for Competitiveness: A Spatial Econometric Approach*. *Papers in Regional Science* 87: 453–75. [CrossRef]
- Cole, Matthew A. 2007. Corruption, Income and the Environment: An Empirical Analysis. *Ecological Economics* 62: 637–47. [CrossRef]
- Dasgupta, Susmita, Benoit Laplante, Hua Wang, and David Wheeler. 2002. Confronting the Environmental Kuznets Curve. *Journal of Economic Perspectives* 16: 147–68. [CrossRef]
- Dasgupta, Susmita, Kirk Hamilton, Kiran D. Pandey, and David Wheeler. 2006. Environment during Growth: Accounting for Governance and Vulnerability. *World Development* 34: 1597–611. [CrossRef]
- Deacon, Robert T., and Catherine S. Norman. 2006. Does the Environmental Kuznets Curve Describe How Individual Countries Behave? *Land Economics* 82: 291–315. [CrossRef]
- Delfanti, Lavinia, Andrea Colantoni, Fabio Recanatesi, Massimiliano Bencardino, Adele Sateriano, Ilaria Zambon, and Luca Salvati. 2016. Solar Plants, Environmental Degradation and Local Socioeconomic Contexts: A Case Study in a Mediterranean Country. *Environmental Impact Assessment Review* 61: 88–93. [CrossRef]
- Destek, Mehmet Akif, and Samuel Asumadu Sarkodie. 2019. Investigation of Environmental Kuznets Curve for Ecological Footprint: The Role of Energy and Financial Development. *Science of The Total Environment* 650: 2483–89. [CrossRef]
- Destek, Mehmet Akif, Recep Ulucak, and Eyup Dogan. 2018. Analyzing the Environmental Kuznets Curve for the EU Countries: The Role of Ecological Footprint. *Environmental Science and Pollution Research* 25: 29387–96. [CrossRef]
- Dinda, Soumyananda. 2004. Environmental Kuznets Curve Hypothesis: A Survey. *Ecological Economics* 49: 431–55. [CrossRef]
- Dumanski, J., W. W. Pettapiece, and R. J. McGregor. 1998. Relevance of Scale Dependent Approaches for Integrating Biophysical and Socio-Economic Information and Development of Agroecological Indicators. *Nutrient Cycling in Agroecosystems* 50: 13–22. [CrossRef]
- Esposito, Piero, Fabrizio Patriarca, Luigi Perini, and Luca Salvati. 2016. Land Degradation, Economic Growth and Structural Change: Evidences from Italy. *Environment, Development and Sustainability* 18: 431–48. [CrossRef]
- Esposito, Piero, Fabrizio Patriarca, and Luca Salvati. 2018. Tertiarization and Land Use Change: The Case of Italy. *Economic Modelling* 71: 80–86. [CrossRef]
- Expósito, Alfonso, María Pablo-Romero, and Antonio Sánchez-Braza. 2019. Testing EKC for Urban Water Use: Empirical Evidence at River Basin Scale from the Guadalquivir River, Spain. *Journal of Water Resources Planning and Management* 145: 04019005. [CrossRef]
- Ferrara, Agostino, Claire Kelly, Geoff A. Wilson, Angelo Nolè, Giuseppe Mancino, Sofia Bajocco, and Luca Salvati. 2016. Shaping the Role of <fast> and <Slow> Drivers of Change in Forest-Shrubland Socio-Ecological Systems. *Journal of Environmental Management* 169: 155–66. [CrossRef]
- Fingleton, Bernard. 2016. Externalities, Economic Geography, And Spatial Econometrics: Conceptual and Modeling Developments. *International Regional Science Review*. [CrossRef]
- Fotheringham, A. S., C. Brunson, and M. Charlton. 2002. *Geographically Weighted Regression: The Analysis of Spatially Varying Relationships*. Hoboken: Wiley.
- Franceschi, Dina, and James R. Kahn. 2003. Beyond strong sustainability. *International Journal of Sustainable Development & World Ecology* 10: 211–20. [CrossRef]
- Galeotti, Marzio. 2007. Economic Growth and the Quality of the Environment: Taking Stock. *Environment, Development and Sustainability* 9: 427–54. [CrossRef]
- Galeotti, Marzio, Alessandro Lanza, and Francesco Pauli. 2006. Reassessing the Environmental Kuznets Curve for CO₂ Emissions: A Robustness Exercise. *Ecological Economics* 57: 152–63. [CrossRef]
- Geoff, A. Wilson, and Meri Juntti, eds. 2005. *Unravelling Desertification*. Wageningen: Wageningen Academic Publishers. [CrossRef]
- Gigliarano, Chiara, and Francesco Maria Chelli. 2016. Measuring Inter-Temporal Intragenerational Mobility: An Application to the Italian Labour Market. *Quality & Quantity* 50: 89–102. [CrossRef]
- Gill, Abid Rashid, Kuperan K. Viswanathan, and Sallahuddin Hassan. 2017. Is Environmental Kuznets Curve Still Relevant? *International Journal of Energy Economics and Policy* 7: 156–65.

- Harbaugh, William, Arik Levinson, and David Wilson. 2000. Reexamining the Empirical Evidence for an Environmental Kuznets Curve. Working Paper 7711. *The Review of Economics and Statistics* 84: 541–51. [\[CrossRef\]](#)
- Heerink, Nico, Abay Mulatu, and Erwin Bulte. 2001. Income Inequality and the Environment: Aggregation Bias in Environmental Kuznets Curves. *Ecological Economics* 38: 359–67. [\[CrossRef\]](#)
- Heidkamp, C. Patrick. 2008. A Theoretical Framework for a ‘Spatially Conscious’ Economic Analysis of Environmental Issues. *Geoforum* 39: 62–75. [\[CrossRef\]](#)
- Hill, Robert J., and Elisabetta Magnani. 2002. An Exploration of the Conceptual and Empirical Basis of the Environmental Kuznets Curve. *Australian Economic Papers* 41: 239–54. [\[CrossRef\]](#)
- Incerti, G., E. Feoli, L. Salvati, A. Brunetti, and A. Giovacchini. 2007. Analysis of Bioclimatic Time Series and Their Neural Network-Based Classification to Characterise Drought Risk Patterns in South Italy. *International Journal of Biometeorology* 51: 253–63. [\[CrossRef\]](#) [\[PubMed\]](#)
- Jaffe, Adam B., Richard G. Newell, and Robert N. Stavins. 2005. A Tale of Two Market Failures: Technology and Environmental Policy. *Ecological Economics* 54: 164–74. [\[CrossRef\]](#)
- James, Alexander N. 1999. Agricultural Land Use and Economic Growth: Environmental Implications of the Kuznets Curve. *International Journal of Sustainable Development* 2: 530–53. [\[CrossRef\]](#)
- Jha, Raghendra, and K. V. Bhanu Murthy. 2003. An Inverse Global Environmental Kuznets Curve. *Journal of Comparative Economics* 31: 352–68. [\[CrossRef\]](#)
- Kahuthu, A. 2006. Economic Growth and Environmental Degradation in a Global Context. *Environment, Development and Sustainability* 8: 55–68. [\[CrossRef\]](#)
- Kaika, Dimitra, and Efthimios Zervas. 2013a. The Environmental Kuznets Curve (EKC) Theory. Part B: Critical Issues. *Energy Policy* 62: 1403–11. [\[CrossRef\]](#)
- Kaika, Dimitra, and Efthimios Zervas. 2013b. The Environmental Kuznets Curve (EKC) Theory—Part A: Concept, Causes and the CO₂ Emissions Case. *Energy Policy* 62: 1392–402. [\[CrossRef\]](#)
- Kairis, O., C. Karavitis, A. Kounalaki, L. Salvati, and C. Kosmas. 2013. The Effect of Land Management Practices on Soil Erosion and Land Desertification in an Olive Grove. *Soil Use and Management* 29: 597–606. [\[CrossRef\]](#)
- Kairis, Orestis, Christos Karavitis, Luca Salvati, Aikaterini Kounalaki, and Kostas Kosmas. 2015. Exploring the Impact of Overgrazing on Soil Erosion and Land Degradation in a Dry Mediterranean Agro-Forest Landscape (Crete, Greece). *Arid Land Research and Management* 29: 360–74. [\[CrossRef\]](#)
- Karamesouti, M., V. Detsis, A. Kounalaki, P. Vasilio, L. Salvati, and C. Kosmas. 2015. Land-Use and Land Degradation Processes Affecting Soil Resources: Evidence from a Traditional Mediterranean Cropland (Greece). *Catena* 132: 45–55. [\[CrossRef\]](#)
- Katircioğlu, Setareh, and Salih Katircioğlu. 2018. Testing the role of urban development in the conventional Environmental Kuznets Curve: Evidence from Turkey. *Applied Economics Letters* 25: 741–46. [\[CrossRef\]](#)
- Kazemzadeh-Zow, Ali, Saeed Zanganeh Shahraki, Luca Salvati, and Najmeh Neisani Samani. 2017. A spatial zoning approach to calibrate and validate urban growth models. *International Journal of Geographical Information Science* 31: 763–82. [\[CrossRef\]](#)
- Kim, Yoomi, Katsuya Tanaka, and Chazhong Ge. 2018. Estimating the Provincial Environmental Kuznets Curve in China: A Geographically Weighted Regression Approach. *Stochastic Environmental Research and Risk Assessment* 32: 2147–63. [\[CrossRef\]](#)
- Kosmas, Costas, Mina Karamesouti, Kate Kounalaki, Vassilis Detsis, Penny Vassiliou, and Luca Salvati. 2016. Land Degradation and Long-Term Changes in Agro-Pastoral Systems: An Empirical Analysis of Ecological Resilience in Asteroussia - Crete (Greece). *Catena* 147: 196–204. [\[CrossRef\]](#)
- Lamonica, Giuseppe Riccardo, and Francesco Maria Chelli. 2018. The Performance of Non-Survey Techniques for Constructing Sub-Territorial Input-Output Tables. *Papers in Regional Science* 97: 1169–202. [\[CrossRef\]](#)
- Lamonica, Giuseppe R., Maria C. Recchioni, Francesco M. Chelli, and Luca Salvati. 2020. The efficiency of the cross-entropy method when estimating the technical coefficients of input–output tables. *Spatial Economic Analysis* 15: 62–91. [\[CrossRef\]](#)
- Lantz, Van. 2002. Is There an Environmental Kuznets Curve for Clearcutting in Canadian Forests? *Journal of Forest Economics* 8: 199–212. [\[CrossRef\]](#)
- Li, Tingting, Yong Wang, and Dingtao Zhao. 2016. Environmental Kuznets Curve in China: New Evidence from Dynamic Panel Analysis. *Energy Policy* 91: 138–47. [\[CrossRef\]](#)

- Lin, Boqiang, Oluwasola E. Omoju, Ngozi M. Nwakeze, Jennifer U. Okonkwo, and Ebenezer T. Megbowon. 2016. Is the Environmental Kuznets Curve Hypothesis a Sound Basis for Environmental Policy in Africa? *Journal of Cleaner Production* 133: 712–24. [\[CrossRef\]](#)
- List, John A., and Craig A. Gallet. 1999. The Environmental Kuznets Curve: Does One Size Fit All? *Ecological Economics* 31: 409–23. [\[CrossRef\]](#)
- Luzzati, Tommaso, Marco Orsini, and Gianluca Gucciardi. 2018. A Multiscale Reassessment of the Environmental Kuznets Curve for Energy and CO₂ Emissions. *Energy Policy* 122: 612–21. [\[CrossRef\]](#)
- Madden, Ben, Nick Florin, Steve Mohr, and Damien Giurco. 2019. Using the Waste Kuznet's Curve to Explore Regional Variation in the Decoupling of Waste Generation and Socioeconomic Indicators. *Resources, Conservation, and Recycling* 49: 674–86. [\[CrossRef\]](#)
- Maddison, David. 2006. Environmental Kuznets Curves: A Spatial Econometric Approach. *Journal of Environmental Economics and Management* 51: 218–30. [\[CrossRef\]](#)
- Maddison, David. 2007. Modelling Sulphur Emissions in Europe: A Spatial Econometric Approach. *Oxford Economic Papers* 59: 726–43. [\[CrossRef\]](#)
- Magnani, Elisabetta. 2000. The Environmental Kuznets Curve, Environmental Protection Policy and Income Distribution. *Ecological Economics* 32: 431–43. [\[CrossRef\]](#)
- Magnani, Elisabetta. 2001. The Environmental Kuznets Curve: Development Path or Policy Result? *Environmental Modelling & Software* 16: 157–65. [\[CrossRef\]](#)
- Marston, Sallie A, John Paul Jones III, and Keith Woodward. 2005. Human geography without scale. *Transactions of the Institute of British Geographers* 30: 416–32. [\[CrossRef\]](#)
- Mazzanti, Massimiliano, Anna Montini, and Roberto Zoboli. 2008. Environmental Kuznets Curves for Air Pollutant Emissions in Italy: Evidence from Environmental Accounts (NAMEA) Panel Data. *Economic Systems Research* 20: 277–301. [\[CrossRef\]](#)
- Mukherjee, Sacchidananda, and Vinish Kathuria. 2006. *Is Economic Growth Sustainable? Environmental Quality of Indian States Post 1991*. SSRN Scholarly Paper ID 1020544. Rochester: Social Science Research Network.
- Müller-Fürstenberger, Georg, and Martin Wagner. 2007. Exploring the Environmental Kuznets Hypothesis: Theoretical and Econometric Problems. *Ecological Economics* 62: 648–60. [\[CrossRef\]](#)
- Munasinghe, Mohan. 1999. Is Environmental Degradation an Inevitable Consequence of Economic Growth: Tunneling through the Environmental Kuznets Curve. *Ecological Economics* 29: 89–109. [\[CrossRef\]](#)
- Nijkamp, P. 1999. *Environmental and Regional Economics*. Cheltenham: Edward Elgar Publishing.
- North, Peter. 2005. *Scaling Alternative Economic Practices? Blackwell Publishing, Ltd. Some Lessons from Alternative Currencies*. *Transactions of the Institute of British Geographers* 30: 221–33. [\[CrossRef\]](#)
- Özokcu, Selin, and Özlem Özdemir. 2017. Economic Growth, Energy, and Environmental Kuznets Curve. *Renewable and Sustainable Energy Reviews* 72: 639–47. [\[CrossRef\]](#)
- Ozturk, Ilhan, Usama Al-Mulali, and Behnaz Saboori. 2016. Investigating the Environmental Kuznets Curve Hypothesis: The Role of Tourism and Ecological Footprint. *Environmental Science and Pollution Research* 23: 1916–28. [\[CrossRef\]](#)
- Panayotou, Theodore. 1997. Demystifying the Environmental Kuznets Curve: Turning a Black Box into a Policy Tool. *Environment and Development Economics* 2: 465–84. [\[CrossRef\]](#)
- Paudel, Krishna P., Hector Zapata, and Dwi Susanto. 2005. An Empirical Test of Environmental Kuznets Curve for Water Pollution. *Environmental and Resource Economics* 31: 325–48. [\[CrossRef\]](#)
- Ranjan, Ram, and James Shortle. 2007. The Environmental Kuznets Curve When the Environment Exhibits Hysteresis. *Ecological Economics* 64: 204–15. [\[CrossRef\]](#)
- Rasli, Amran Md., Muhammad Imran Qureshi, Aliyu Isah-Chikaji, Khalid Zaman, and Mehboob Ahmad. 2018. New Toxics, Race to the Bottom and Revised Environmental Kuznets Curve: The Case of Local and Global Pollutants. *Renewable and Sustainable Energy Reviews* 81: 3120–30. [\[CrossRef\]](#)
- Recanatesi, Fabio, Matteo Clemente, Efstathios Grigoriadis, Flavia Ranalli, Marco Zitti, and Luca Salvati. 2016. A Fifty-Year Sustainability Assessment of Italian Agro-Forest Districts. *Sustainability* 8: 32. [\[CrossRef\]](#)
- Rehman, Faiz Ur, Muhammad Nasir, and Faiza Kanwal. 2012. Nexus between Corruption and Regional Environmental Kuznets Curve: The Case of South Asian Countries. *Environment, Development and Sustainability* 14: 827–41. [\[CrossRef\]](#)
- Rodrigo-Comino, Jesús, José María Senciales, Artemi Cerdà, and Eric C. Brevik. 2018. The multidisciplinary origin of soil geography: A review. *Earth-Science Reviews* 177: 114–23. [\[CrossRef\]](#)

- Rontos, Kostas, Efstathios Grigoriadis, Adele Sateriano, Maria Syrmali, Ioannis Vavouras, and Luca Salvati. 2016. Lost in Protest, Found in Segregation: Divided Cities in the Light of the 2015 “Oxi” Referendum in Greece. *City, Culture and Society* 7: 139–48. [CrossRef]
- Rosti, Luisa, and Francesco Chelli. 2009. Self-employment among Italian Female Graduates. *Education + Training* 51: 526–40. [CrossRef]
- Rosti, Luisa, and Francesco Chelli. 2012. Higher Education in Non-standard Wage Contracts. *Education + Training* 54: 142–51. [CrossRef]
- Rosti, Luisa, Chikara Yamaguchi, and Carolina Castagnetti. 2005. Educational Performance as Signalling Device: Evidence from Italy. *Economics Bulletin* 9: 1–7.
- Rupasingha, Anil, Stephan J. Goetz, David L. Debertin, and Angelos Pagoulatos. 2004. The Environmental Kuznets Curve for US Counties: A Spatial Econometric Analysis with Extensions*. *Papers in Regional Science* 83: 407–24. [CrossRef]
- Salvati, Luca. 2014. A Socioeconomic Profile of Vulnerable Land to Desertification in Italy. *The Science of the Total Environment* 466–467: 287–99. [CrossRef]
- Salvati, Luca. 2016. The Dark Side of the Crisis: Disparities in per Capita Income (2000–2012) and the Urban-Rural Gradient in Greece. *Tijdschrift Voor Economische En Sociale Geografie* 107: 628–41. [CrossRef]
- Salvati, Luca, and Margherita Carlucci. 2010. Estimating Land Degradation Risk for Agriculture in Italy Using an Indirect Approach. *Ecological Economics* 69: 511–18. [CrossRef]
- Salvati, Luca, and Pere Serra. 2016. Estimating Rapidity of Change in Complex Urban Systems: A Multidimensional, Local-Scale Approach. *Geographical Analysis* 48: 132–56. [CrossRef]
- Salvati, Luca, and Marco Zitti. 2005. Land degradation in the Mediterranean basin: Linking bio-physical and economic factors into an ecological perspective. *Biota* 5: 67–77.
- Salvati, Luca, and Marco Zitti. 2008. Regional Convergence of Environmental Variables: Empirical Evidences from Land Degradation. *Ecological Economics* 68: 162–68. [CrossRef]
- Salvati, Luca, and Marco Zitti. 2009a. Substitutability and Weighting of Ecological and Economic Indicators: Exploring the Importance of Various Components of a Synthetic Index. *Ecological Economics* 68: 1093–99. [CrossRef]
- Salvati, Luca, and Marco Zitti. 2009b. Assessing the Impact of Ecological and Economic Factors on Land Degradation Vulnerability through Multiway Analysis. *Ecological Indicators* 9: 357–63. [CrossRef]
- Salvati, Luca, and Marco Zitti. 2009c. The Environmental “Risky” Region: Identifying Land Degradation Processes Through Integration of Socio-Economic and Ecological Indicators in a Multivariate Regionalization Model. *Environmental Management* 44: 888. [CrossRef]
- Salvati, Luca, Alberto Mancini, Sofia Bajocco, Roberta Gemmiti, and Margherita Carlucci. 2011. Socioeconomic Development and Vulnerability to Land Degradation in Italy. *Regional Environmental Change* 11: 767–77. [CrossRef]
- Salvati, Luca, Roberta Gemmiti, and Luigi Perini. 2012. Land degradation in Mediterranean urban areas: An unexplored link with planning? *Area* 44: 317–25. [CrossRef]
- Salvati, Luca, Marco Zitti, and Luigi Perini. 2016. Fifty Years on: Long-Term Patterns of Land Sensitivity to Desertification in Italy. *Land Degradation & Development* 27: 97–107. [CrossRef]
- Sannigrahi, S., P. K. Joshi, S. Keesstra, S. K. Paul, S. Sen, P. S. Roy, S. Chakraborti, and S. Bhatt. 2019. Evaluating landscape capacity to provide spatially explicit valued ecosystem services for sustainable coastal resource management. *Ocean and Coastal Management* 182. [CrossRef]
- Sannigrahi, Srikanta, Qi Zhang, Francesco Pilla, Pawan Kumar Joshi, Bidroha Basu, Saskia Keesstra, P. S. Roy, Ying Wang, Paul C. Sutton, Suman Chakraborti, and et al. 2020. Responses of ecosystem services to natural and anthropogenic forcings: A spatial regression based assessment in the world’s largest mangrove ecosystem. *Science of the Total Environment* 715. [CrossRef] [PubMed]
- Scarascia, M. E. Venezan, F. Di Battista, and L. Salvati. 2006. Water Resources in Italy: Availability and Agricultural Uses. *Irrigation and Drainage* 55: 115–27. [CrossRef]
- Smiraglia, D., T. Ceccarelli, S. Bajocco, L. Salvati, and L. Perini. 2016. Linking Trajectories of Land Change, Land Degradation Processes and Ecosystem Services. *Environmental Research* 147: 590–600. [CrossRef] [PubMed]
- Smulders, J. A. 1999. Endogenous Growth Theory and the Environment. In *Handbook of Environmental and Resource Economics*. Amsterdam: Edward Elgar Publishing, pp. 610–21.

- Sobhee, Sanjeev K. 2004. The environmental Kuznets curve (EKC): A logistic curve? *Applied Economics Letters* 11: 449–52. [[CrossRef](#)]
- Spangenberg, Joachim H. 2001. The Environmental Kuznets Curve: A Methodological Artefact? *Population and Environment* 23: 175–91. [[CrossRef](#)]
- Stern, David I. 1998. Progress on the Environmental Kuznets Curve? *Environment and Development Economics* 3: 173–96. [[CrossRef](#)]
- Stern, David I. 2004. The Rise and Fall of the Environmental Kuznets Curve. *World Development* 32: 1419–39. [[CrossRef](#)]
- Tan, Xiaomei. 2006. Environment, Governance and GDP: Discovering Their Connections. *International Journal of Sustainable Development* 9: 311. [[CrossRef](#)]
- Vincent, Jeffrey R. 1997. Testing for Environmental Kuznets Curves within a Developing Country. *Environment and Development Economics* 2: 417–31. [[CrossRef](#)]
- Wang, Pingo, Alok K. Bohara, Robert P. Berrens, and Kishore Gawande. 1998. A risk-based environmental Kuznets curve for US hazardous waste sites. *Applied Economics Letters* 5: 761–63. [[CrossRef](#)]
- Xie, Qichang, Xin Xu, and Xiaqing Liu. 2019. Is There an EKC between Economic Growth and Smog Pollution in China? New Evidence from Semiparametric Spatial Autoregressive Models. *Journal of Cleaner Production* 220: 873–83. [[CrossRef](#)]
- Yamamoto, Daisaku. 2008. Scales of Regional Income Disparities in the USA, 1955–2003. *Journal of Economic Geography* 8: 79–103. [[CrossRef](#)]
- Zaim, Osman, and Fatma Taskin. 2000. A Kuznets Curve in Environmental Efficiency: An Application on OECD Countries. *Environmental and Resource Economics* 17: 21–36. [[CrossRef](#)]
- Zaman, Khalid, Muhammad Shahbaz, Nanthakumar Loganathan, and Syed Ali Raza. 2016. Tourism Development, Energy Consumption and Environmental Kuznets Curve: Trivariate Analysis in the Panel of Developed and Developing Countries. *Tourism Management* 54: 275–83. [[CrossRef](#)]
- Zoundi, Zakaria. 2017. CO₂ Emissions, Renewable Energy and the Environmental Kuznets Curve, a Panel Cointegration Approach. *Renewable and Sustainable Energy Reviews* 72: 1067–75. [[CrossRef](#)]
- Zuindeau, Bertrand. 2007. Territorial Equity and Sustainable Development. *Environmental Values* 16: 253–68. [[CrossRef](#)]



© 2020 by the authors. Licensee MDPI, Basel, Switzerland. This article is an open access article distributed under the terms and conditions of the Creative Commons Attribution (CC BY) license (<http://creativecommons.org/licenses/by/4.0/>).



Article

Resource Rents, Human Development and Economic Growth in Sudan

Elwasila Saeed Elamin Mohamed

Department of Economics, University of Khartoum, P.O. Box 321, Khartoum 1115, Sudan;
elwasila.sem@gmail.com

Received: 12 July 2020; Accepted: 28 October 2020; Published: 16 November 2020

Abstract: This study investigates the relationship between natural resource rents, human development and economic growth in Sudan using co-integration and vector error correction modelling (VECM) over the period 1970–2015. Institutions proved to play a role in determining a difference in whether a country is cursed or blessed by resource abundance. In the case of Sudan, no time series data is available on institutional quality and is therefore excluded from the analysis. The role of institutions and macroeconomic policies is captured by other variables included in the empirical model. Co-integration tests confirm the existence of a long run equilibrium relationship between resource rents, human development and economic growth in Sudan. Empirical evidence from the estimated VECM shows that economic growth is positively affected by resource rents and development expenditure but surprisingly negatively affected by life expectancy at birth in the short run. In the long run, resource rents, school enrolment, life expectancy and financial development have negative significant effects on economic growth. Only development expenditure is found to affect economic growth positively. Resource rents are found to weaken education and health levels and this is indirectly channeled into negative effects of resource rents on economic growth. These results suggest that the government has been neglecting investments to build up human capital necessary for inclusive growth. Long run Granger causality tests show a unidirectional causal relationship running from resource rents to GDP growth as well as from development expenditure to GDP growth. School enrollment, life expectancy and financial development are found to be negatively Granger causing GDP growth. Long run causal relationships reconfirm that a resource curse exists indirectly mediated by weak human capital. The study recommends that the government should manage natural resource rents with a policy framework supporting creation of a virtuous economic circle between human development and economic growth. If pursued, this would promote sustained, inclusive and equitable growth in Sudan.

Keywords: resource rents; human development; development expenditure; financial development; economic growth; co-integration; VECM; Sudan

1. Introduction

Natural resources play important roles in economic growth of any country. Natural, man-made and human capitals are conventional factors of economic growth and represent the main components in environmental sustainability accounting. In developing countries, natural capital supplements man-made capital, if not substituting it in production. For example, resource revenues and taxes can be used by governments to finance infrastructure projects and human capital formation, which generate economic growth. Revenues from natural resources in capital-scarce developing countries supplement limited fiscal capacity of governments for spending in human capital assets (Venables 2016; Sabine et al. 2016). But, it proved difficult to transform resource revenues into productive assets in resource-rich countries, Venables (2016), and natural resources have negative effects on provision of productive

infrastructures, [Sarr and Wick \(2010\)](#). [van der Ploeg and Poelhekke \(2009\)](#) show that volatility of resource rents in particular contributes to poor planning and disturbs government spending. It has also been pointed out that in resource abundant countries policy frameworks are not strong enough to support implementation of sound fiscal policy in taxing and spending ([Daniel et al. 2013](#)). Rather than accumulating productive assets, it has been found that resource abundance crowds out human capital in education and investment and thus hinders economic growth ([Gylfason 2001a, 2001b](#); [Gylfason and Zoega 2003, 2006](#); [Gylfason et al. 1999](#); [Cockx and Francken 2015](#)). The same crowding out effect of resource abundance is found in investment in health ([Cockx and Francken 2014](#)). To put it conversely, managing resources in ways that prioritize investments in human capital formation can play a significant role in economic growth, its quality and inclusiveness ([Mejía 2012](#); [World Bank 2011](#)).

Sudan is a typical case of resource abundance. Since the late 1990s the Sudan economy becomes resource-dependent as oil exports as percentage of total exports amounted to 97 percent and resource revenues as a percentage of total revenue amounted to 55 percent over the period 2000–2012. Meanwhile, Sudan has deficient productive infrastructures, low human capital investments and outcomes resulting in poor economic growth. In particular, the country has experienced increasing resource rents since the mid-1990s, which could have been a real opportunity to finance investments in education and health, leading to human development and promoting inclusive growth. However, resource revenues and rents in Sudan have likely been squandered, aggravated by unstable economic policies, weak political institutions, bad governance and international resource market shocks. These factors have given the country a case of resource curse (RC).

This study adds to the debate on the RC with empirical testing from Sudan. It investigates the direct effect of resource rents on economic growth, and the indirect effects of resource rents on economic growth channeled through education and health. The case of Sudan is interesting for three reasons.

First, this study addresses the relevance of the RC in the case of Sudan as a single developing country. Sudan is endowed with vast and diverse natural resources including arable lands, water, oil and mineral resources. But the country has failed to achieve positive and stable economic growth rates since the 1970s.

Secondly, a nexus of resource rents, human development and growth is dynamically examined over a period of 46 years spanning over 1970–2015. This is a relatively long period to capture the historical processes of growth with resource rents in a single country. Panel country studies suffer the weakness of capturing such historical process on the RC ([Lederman and Maloney 2008](#)). Cross-sectional growth regressions, which are often used in investigations of the RC, have also been criticized for suffering from omitted variable bias because of the correlation between the initial income and the omitted initial level of productivity ([van der Ploeg 2011](#)).

Thirdly, the current study scrutinizes [Elwasila Saeed Elamin \(2017a\)](#) who finds a positive relationship between health and economic growth in Sudan but without consideration of the role of resource abundance.

Sudan has been performing poorly in human capital formation—both in terms education and health, despite remarkable annual economic growth records backed with an oil boom over the period 1999–2012. Resource rents as a percentage of gross domestic product (GDP) have been fluctuating from almost zero in the early seventies to as high as 21.76 in 2008, down to 8.64 in 2013 and further down to 4.20 in 2015. Over the period 1999–2012, natural resource exports as a percentage of total exports amounted to 97 percent and resource revenues as a percentage of total revenue amounted to 55 percent ([Ministry of Finance and National Economy 2000–2013](#)) of Sudan, Annual Economic Reports 2000–2013). These percentage contributions indicate the importance of natural resources to economic growth and place Sudan within a group of 51 countries classified by the IMF as resource-rich countries over the period 2000–2006 ([Venables 2016](#)). Sudan's annual current GDP growth averaged 4.28 percent over the period 1970–2015. It averaged 4.97 percent over the period 1990–2012. Sudan achieved the highest average GDP growth of 5.24 percent over the period of the oil boom (1999–2012). Immediately after losing oil revenues due to secession of South Sudan in July 2011, Sudan's current

GDP growth declined to minus 2.09 percent over the two years of 2011 and 2012. Real GDP growth rates have also been trending up positively over the period 1999 to 2012 in line with increasing oil revenues and rents. Over that period economic growth was also associated with a one-digit inflation rate and stable prices and exchange rate. But real GDP growth rate declined to negative records in 2012 and 2013, due to sharp decline of oil revenues. GDP growth again started to trend upward in 2014 and 2015, with increasing gold extraction and revenues. On the other hand, achievements in human development indicators have been low and slow over the period 1970–2015. For example, net primary school enrollment was 21.78 in 1970, increased to 26.52 in 1998, to 40.23 in 2000 and stood at 45.78 in 2015. Education expenditure as percentage of gross national income has increased from 3.70 in 1971 to 3.93 in 1980, but it has been decreasing since then to reach 2.18 in 2015. The lowest values of primary school enrollment were recorded over the period of the booming oil sector (1999–2012). Government expenditure on education as a percentage of GDP averaged 1.90 over the period 1999–2012, indicating a massive gap of 3.10 from the 5 percent suggested by the Educational for All initiative of the United Nations. Life expectancy at birth was 51.74 years in 1970, increased to 57.34 years in 1998 and stood at 63.92 years in 2015. Public health spending as percentage of GDP averaged 1.02 percent over the period 1970–2015, and was slightly higher at 1.61 in the sub-period of 1999–2012 (World Bank 2017a). Sudan has also been performing poorly in terms of governance and institutions. For example, in 2015, Sudan scored 3.94 in voice and accountability, 3.81 in political stability, 6.25 in government effectiveness, 4.81 in regulatory quality, 8.17 in rule of law and 2.40 in control of corruption (World Bank 2017b). According to the Natural Resource Governance Institute (2017) in 2017, Sudan scored just 21 out of 100 points in resource governance index and ranked as 86 out of 89 oil and gas rich countries. Sudan also scored the least value of an average of 0.27 in an institutional quality index constructed by Bakwena et al. (2009) for a sample of 53 countries over the period 1984–2003.

In light of the above introduction, the objective of this study is to empirically investigate the relationship between resource rents, human development and economic growth in Sudan over the period 1970–2015. The study addresses this objective through two questions; (i) how resource rents directly affect economic growth and (ii) how the effect of resource rents on human capital in terms of education and health is indirectly channeled to economic growth?

2. Literature Review

Experiences of developing resource-rich countries reveal that these countries not only have slow economic growth rates but that they are vulnerable to deterioration in all forms of capital. As such, it has been argued that natural resource abundance is more of a curse than a blessing for many developing countries (Brunnschweiler 2008) among many others. Karl (1997) uses the concept of paradox of plenty in explaining the RC hypotheses in oil-rich countries, namely Venezuela, Nigeria and Algeria, and concluded oil money depletes state capabilities. Even in well-established market economies and democracies, Papyrakis and Gerlagh (2007) find a negative correlation across the United States states between the growth rate of gross State product (GSP) and the share of the primary sector as well as between the share of employment in mining and GSP.

However, findings of empirical studies on the relationship between resource abundance and economic development are mixed, inconclusive and still controversial (Stern 2003; Stijns 2005; Brunnschweiler and Bulte 2008). Lederman and Maloney (2008) state that existing empirical evidence suggests that the curse remains elusive. This according to them is due to heterogeneity and the use of weak indicators of resource endowments, and to the inability of econometric analysis based on international data to capture historical growth processes. In contrast to the negative outcomes, Davis and Tilton (2005) in a cross-section study find that resource abundance has a positive relationship with economic development. Alexeev and Conrad (2009) show that large endowments of oil and minerals have a positive effect on long-term economic growth. Meanwhile, most studies find that resource abundance exerts negative effects on economic development within the context of RC, Havranek et al. (2016). But, the RC, first coined by Auty (1993) is a relative concept stating that resource-rich countries

have slower economic growth when compared with resource-poor countries. Existence and degree of the RC has been explained in a political economy context with focus on the role of democracy, rule of law, institutions and overall public policies and governance (Sachs and Warner 1995, 1997a, 1997b; Ascher 1999; Auty 2001a, 2001b, 2010; Auty and Sampsa 2001; Isham et al. 2005; Mehlum et al. 2006; Elbadawi and Soto 2015). In Sub Saharan (SSA) countries, Lundgren et al. (2013) stated that transforming natural resource wealth into productive human, physical and financial assets is hindered by weak institutional capacities in these countries. Another strand of literature in explaining the RC focuses on the role of rent seeking (Bulte et al. 2005; Wick and Erwin 2006; Deacon and Ashwin 2012) and conflicts and civil wars (Collier and Hoeffler 1998, 2004). van der Ploeg (2011) finds that resource booms reinforce rent grabbing and civil conflict, especially if institutions are bad. Resource booms induce corruption especially in nondemocratic countries, and resource rich developing economies seem unable to successfully convert their depleting exhaustible resources into other productive assets (van der Ploeg 2011). One prominent economic explanation of the RC is the Dutch Disease (DD) hypothesis. The DD hypothesis states that increases in resource revenues lead to appreciation of the domestic currency, which in turn enhances the non-tradable goods sector at the expense of the non-resource exports sector. The outcome is described as deindustrialization Corden and Neary (1982) and Corden (1984). Sachs and Warner (2001) show that natural resources crowd out manufacturing due to depressed competitiveness of manufacturers in export markets. van der Ploeg (2011) finds that resource abundance induces appreciation of the real exchange rate leading to deindustrialization and bad growth. According to them these adverse effects are more severe with bad institutions, lack of rule of law, corruption and underdeveloped financial systems. Warner (2015), for a sample of developing countries, shows that huge economic rents are associated with booming prices of nonrenewable resources and have no positive impacts outside the non-resource sectors. There are, however, some exceptions among the resource-abundant countries suggesting that the RC could be avoided or at least mitigated. Success stories are documented in Mehlum et al. (2011) for Norway, Havro and Santiso (2008) in comparing oil-rich Norway and copper-rich Chile, Gelb and Grasmann (2010) for Botswana, Chile, Indonesia and Malaysia. Upon critical discussions of findings of prominent studies on the RC, Peretto (2008) distinguishes between the effect of resource abundance on income growth and on welfare change. The author finds that while income and welfare are hump-shaped functions of resource abundance, the welfare effect depends on the whole path of consumption. The author argues that such distinction applies to all explanations of the curse including future research in the field. Mehrara and Javad (2015) descriptively investigate the effect of resource rents on economic growth in Iran and MENA countries, concluding that natural resources have been more of a curse than a blessing. Meanwhile, their empirical findings from an ordinary least square (OLS) model show that resource rents have positive and significant effect on economic growth. This controversy becomes a bit more complicated when human capital is included, together with government policies toward education and health sectors in resource-rich developing countries. However, Maty (2012) shows that education and economic institutions play no important role on whether a country is blessed or cursed by resources and the differing experiences are mainly explained by level of democracy. Review and assessment of the RC literature can be found in Stevens et al. (2015) and an elaborative survey can be found in Frankel (2012).

It seems from the empirical literature that the debate on existence of the RC evolves around three contexts, which are:

- (i) how resource abundance and intensity is measured,
- (ii) type of resources (point vs. diffuse sources), and
- (iii) type of econometric setting and modeling adopted.

Some examples suffice to show this. Leite and Weidmann (1999) used resource exports over gross national product (GNP) in a cross-section study and found that resource abundance impedes growth through creation of rent seeking and corruption. Ross (2001) used resource rents over GDP

in a panel data study and found that while exports of oil and mineral are strongly associated with authoritarian rule, exports of agricultural goods were not. [Bhattacharyya and Collier \(2013\)](#) in a panel data study found that rents from mineral resources reduce the public capital stock, while rents from forestry and agriculture do not. [Dietz et al. \(2007\)](#) used natural resource exports over total exports in a panel data study and found that resource abundance has a negative effect on genuine saving. They argued that this effect can be mitigated by improvement of quality of governance. [Boschini et al. \(2013\)](#) used natural resource exports over GDP in panel and cross section study and found that ores and metals rents with low institutional quality have a negative effect on growth. [Beck \(2011\)](#) used natural resource exports over total exports in a cross-section study and found that resource windfall leads to underinvestment in the financial sector with long-term negative effects on economic growth. [Beck and Steven \(2017\)](#), in a panel data of 150 countries using structural vector autoregressive (VAR) models, found that natural resources undermine the development of the financial sector.

Investigations of the RC hypothesis need to be placed in the context of sustainability. This is simply because the RC is expected to be more associated with finite supply point-resources than with diffuse resources. It is thus argued that rents from non-renewable resources should be invested in the formation of physical capital ([Hartwick 1977](#)) or in renewable natural capital ([Daly 1994](#)). [Hamilton and Clemens \(1999\)](#) show that changes in human capital shift the genuine saving rates upwards in low- and high-income countries. [Hamilton \(2001\)](#) analyzed the sustainability of extractive economies and found that the genuine saving rate declined with the depletion share of GDP in resource-dependent economies in 1997. [Neumayer \(2004\)](#), for a sample of 20 countries, found that resource-intensive economies grow slower in terms of genuine income, but the RC is weaker in terms of growth of genuine income than growth of GDP. [Hamilton et al. \(2006\)](#) employed time series data on investment and rents for 70 countries resource-abundant countries in the context of the Hartwick Rule. They found that Venezuela, Trinidad and Tobago and Gabon would have produced as much capital as South Korea, while Nigeria would have five times its current level. [Arrow et al. \(2012\)](#) developed a comprehensive wealth measure including reproducible, human, natural capital and technological change. They applied it to five countries, namely the United States, China, Brazil, India and Venezuela. They show that technological change, natural and health capital fundamentally affect achievements in sustainability. [Apergis and Payne \(2014\)](#) examined the impact of oil abundance on economic growth in a number of Middle East and North African (MENA) countries for the period 1990–2013. Their results show that better institutional quality reduces the unfavorable effect of oil reserves on the economy.

It is not only abundance of natural resources, but also the fluctuation of prices of these resources that could have impacts on economic growth. Oil prices in particular are volatile and this volatility has negative impacts on macroeconomic performance in both oil producing and oil consuming countries. In oil consuming countries high price levels could reduce real wages, labor supply and demand for energy and, accordingly, negatively affect economic growth. [Zhang \(2008\)](#) investigated the relationship between oil price shocks and economic growth in Japan, and found that increases in oil prices have a larger impact on growth than decreases in oil prices. However, for oil-exporting countries, higher oil prices lead to increases in revenues, and if such booms lead to importation of capital goods and investments, oil revenues should increase production and economic growth. [Keikha et al. \(2012\)](#) investigated the impacts of oil prices on economic growth in 32 oil-rich countries, applying panel co-integration and an error correction model. They showed that sufficiently high institutional quality helps countries avoid the negative impacts of oil price fluctuations. They also found that trade openness has a positive and significant effect on economic growth.

Human capital has received great deal of attention in the empirical literature of economic growth, particularly in the context of the endogenous growth theory. The widely held argument is that human capital in terms of good education and health has positive effect on economic growth ([Romer 1990](#); [Barro and Lee 1994](#); [Barro 1996, 2013](#); [Sachs and Warner 1997b](#); [Weil 2005](#)). [Bloom et al. \(2004\)](#) in a neoclassical growth model find that schooling and life expectancy positively contribute to economic growth. However, such arguments and findings are challenged by the possibility of a resource curse

in education and health. Resource abundance may lead to underinvestment in human capital, in both education and health. [Birdsall et al. \(2001\)](#) state that resource-rich countries have low levels of education such as Brazil, while resource-poor countries have high levels of education such as Korea. These disincentives to invest in human capital are channeled into negative effects on economic growth. [Papyrakis and Gerlagh \(2004\)](#) used natural resource production over GDP in a panel data study and found that the natural resources have a negative impact on growth when considered in isolation, but a positive impact on growth when schooling is included. In a sample of developed and developing countries with pooled cross-section methods, [Stijns \(2006\)](#) found that resource abundance positively correlated with both education and life expectancy while resource dependence negatively correlated with both education and life expectancy. In contrast, [Daniele \(2011\)](#) in a panel data study found that human development is negatively correlated with resource dependence, but positively correlated with resource abundance. [Pineda and Rodriguez \(2010\)](#) show that exports of natural resources positively correlate with both economic growth and changes in the Human Development Index. [Kurtz and Brooks \(2011\)](#) empirically show that differences in human capital and trade openness make resource wealth either a curse or a blessing. [Shao and Yang \(2014\)](#) explain the RC in models involving human capital and the role of government in creating economic virtuous circle. They show that rise in the discount rate, the elasticity of intertemporal substitution and resource prices adversely affect the virtuous circle, while high-quality education and institutions prioritizing manufacturing are a necessary and sufficient condition for forming the virtuous economic circle between human capital, resource abundance and economic growth. Using panel data, [Cockx and Francken \(2014\)](#) show the existence a resource curse in public health spending. Also, [Cockx and Francken \(2015\)](#) in a panel of 140 countries over the period 1995–2009 found that resource rents, particularly from point-source resources, crowd-out public expenditure on education.

[Kim and Lin \(2016\)](#) examined the effect of natural resources on education and health in a sample of 19 OECD and 36 Non-OECD countries. They found that natural resource dependence has a significant positive effect on education but a negative effect on health. They also found that while agricultural exports lower education and health, non-agricultural primary exports promote both. [Ibrahim et al. \(2018\)](#) for 18 SSA countries show that government spending on education and health significantly enhances inclusive growth. In particular, they show that increasing government expenditure on health increases GDP per capita growth in these countries. In contrast, [Oyinlola et al. \(2019\)](#) examined how human capital development and natural resource rent affect industrial development in a sample of 17 SSA, using a fixed effect model. Their findings reveal that spending on health has a direct dragging effect and the negative effect is larger when rents are used for finance. However, they show that the indirect impact of resource rents was negatively mediated through education and but positively mediated through health. Studying economic growth in Uruguay over a period 1870–2014, [Sandonato and Willebald \(2018\)](#) conclude that natural capital abundance itself is an endogenous process caused by host of factors including human capital and terms of trade. Also, [Santos \(2018\)](#) finds that the gold boom is a curse for long run growth in Colombia as it leads to decreases in school enrolment and hurts capital accumulation through child labour.

Studies on resource rents, human development and economic growth in Sudan are rare. [Constantinos et al. \(2014\)](#) applied an autoregressive distributed lag model to investigate the role of institutions on economic growth in Sudan. They found that investment, trade openness and political freedom index as a measure of institutional quality all have negative effects on GDP growth of Sudan over the period 1972–2008. They found only population growth played a positive role. [Arabi and Abdalla \(2013\)](#) used a three-stage OLS method, and found that school attainment and health have positive and significant effects on economic growth in Sudan over the period 1982–2009. They found that the state of technology has a detrimental effect on both economic growth and human development. [Nour \(2010\)](#) shows that insufficient financial and human resources have hampered the potential role of R and D in contributing towards development and adaptation of imported technologies in Sudan. [Selim and Zaki \(2014\)](#) show Sudan as being among the Arab countries that experienced RC with

conflicts and large borrowing. However, none of these studies consider the role of human capital in the presence of resource abundance.

3. Analytical Framework and Econometric Modelling

3.1. Analytical Framework

This study establishes an analytical framework to investigate the relationship between resource rents, human development and economic growth in Sudan without explicit inclusion of institutions. Non-inclusion of a proxy to represent institutions is justified by two factors. First, the role of institution is implicitly reflected in the inputs and output variables linked to resource rents in our model. Second, there is no time series data for any proxy of institutional quality covering the period 1970–2015 in the case of Sudan. Thus, the study addresses this relationship through the direct effect of total resource rents (TRR) on GDP growth and via the indirect effects of TRR on GDP growth channeled through human development in terms of education and health. Education is measured by the average school enrollment (ASE) and health measured by life expectancy at birth (LE). Other variables which are important links to resource rents and economic growth included in our model are development expenditure (DEY), gross investment (INV), financial development measured by domestic credit provided by banks to private firms (DCB) and current account deficit (CAD). The reason for the inclusion of DCB is that resource abundance is found to undermine financial sector development in resource rich developing countries. Also, inclusion of DCB follows the supply-leading hypothesis in that increasing the supply of financial services leads to economic growth.

DEY and INV embody the extent of converting resource revenues and rents into productive assets which are known to create economic growth. CAD is theoretically linked to economic growth, domestic and foreign savings and resource rents, which in Sudan have been running low and are unsustainable (Elwasila Saeed Elamin 2017b). CAD also reflects large borrowing and running down of foreign capital. In order to capture these dynamic relationships, this study proposes an analytical framework in which the effect of natural resource rents on economic growth is mainly mediated through its effect on DEY, INV, ASE, LE, DCB and CAD as sketched in Figure 1.

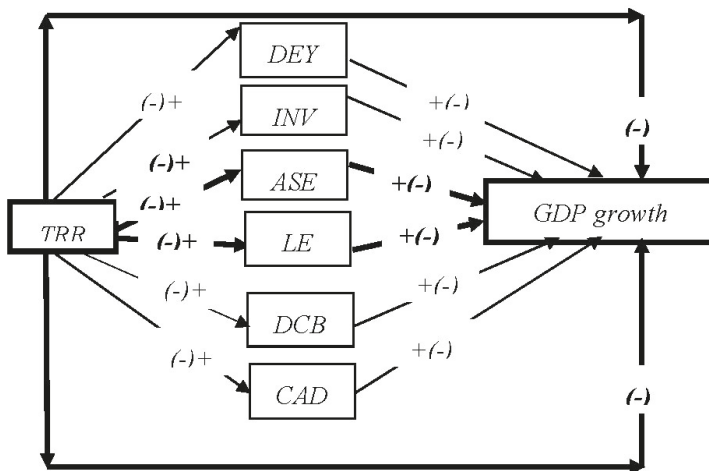

Figure 1. Analytical Framework of Intermediation of Effects of Total Resource Rents on Economic Growth.

In accordance with the objective of the study, the analytical framework enables us to set the following two hypotheses:

- i. The direct effect of TRR on GDP growth is negative.
- ii. The direct effect of TRR on education and health is hypothesized to be negative but it could be positive (-)+, while the transmissible effects of education and health to GDP are hypothesized to be positive but they could be negative +(-).

The analytical framework enables us to empirically test whether resource rents crowd out human capital, and if so, the transmitted effect to economic growth should be negative. This framework is also constructed in line with previous findings of empirical studies on resource abundance, rents, human capital and economic growth. The model also serves as empirical test of the virtuous circle of natural resource and human capital developed by [Birdsall et al. \(2001\)](#). This gives rise to the government role on social and development expenditures in enhancing or breaking possible virtuous circle. The study variables linked in the analytical framework above are defined as follows:

GDP is the current gross domestic product as conventionally defined and measured

TRR is the total rents from oil and forests as percentage of GDP and calculated from the World Development Indicators (WDI), ([World Bank 2017a](#)).

DEY is development expenditure as percentage of GDP.

INV is gross investment, including public and private investments as percentage of GDP.

ASE is average school enrolment in primary education.

LE is life expectancy at birth; taken as the total number of years a new born is expected to live. Because LE also serves as a proxy of other important variables, the relationship between LE and growth is far from being immediate ([Sen 1988](#)).

DCB is domestic credit provided by the banks to the private sector as percentage of GDP.

CAD is current account deficit as percentage of GDP.

Data on all variables is processed from the WDI of the [World Bank \(2017a\)](#).

3.2. Econometric Analysis

3.2.1. Model Specification and Estimations

In line with the theoretical analytical framework set in [Figure 1](#), the study uses a model of aggregate production function to link and explain how resource rents affect economic growth in presence of human capital represented by education and health. With exception of CAD, all variables are expressed in natural logarithms (L) and the model is specified as follows:

$$L(GDP) = \alpha + \beta_1 L(TRR) + \beta_2 L(DEY) + \beta_3 L(INV) + \beta_4 L(ASE) + \beta_5 L(LE) + \beta_6 L(DCB) + \beta_7 CAD + \mu \quad (1)$$

After checking the time series properties in terms of their distribution, stationarity and co-integration, the study builds and estimates a vector error correction model (VECM) to investigate the short run dynamics and long run equilibrium relationships of growth with resource rents and human development in Sudan. The study starts by visualizing the relationship between TRR and economic growth rate (EGR) in Sudan. As shown in [Figure 2](#) over the period 1998–2012, TRR has grown faster than EGR, and in fact while the annual change of TRR averaged 1.16 percent, the annual change of EGR averaged -0.08 percent. These growth paths suggest a sign of a resource curse. The period 1998–2012 also showed a stable exchange rate of the Sudanese Pound against the US Dollar and perhaps an appreciated exchange rate with increasing resource rents.

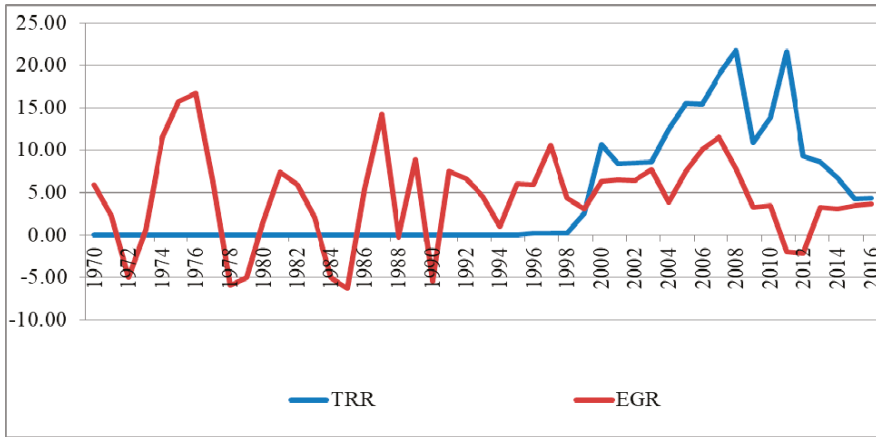

Figure 2. Resource rents and economic growth rates in Sudan (1970–2015).

Figure 3 shows that resource rents over the period 1998–2011 were trending up faster than development expenditure and domestic credit provided by banks. Investment as percentage of GDP has been steadily declining. This suggests that resource rents were not converted into productive assets.

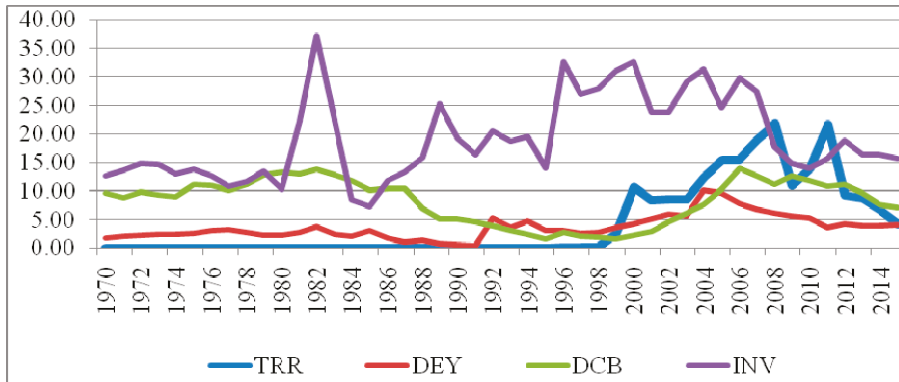

Figure 3. Resource rents, Development Expenditure, Investment and Financial Development in Sudan (1970–2015).

3.2.2. Stationarity and Co-integration Test of the Time Series

In econometric modeling, time series variables need to be stationary for meaningful and un-spurious regressions, [Granger and Newbold \(1974\)](#). This study uses the Augmented Dickey Fuller (ADF) test, [Dickey and Fuller \(1981\)](#) and Phillips Perron (PP) test, [Phillips and Perron \(1988\)](#) to examine presence of unit roots in the model variables. All variables are found to be non-stationary at level, but they all turn to be stationary and integrated at first difference I(1) as presented in Table 1.

Table 1. Unit root test results.

	ADF	PP		ADF	PP
	Level		First Difference		
L(GDP)	-0.452	-0.480	ΔL(GDP)	-6.135 *	-6.135 *
L(TRR)	-0.463	-0.585	ΔL(TRR)	-6.745 *	-6.174 *
L(DEY)	-2.494	-2.476	ΔL(DEY)	-7.729 *	-8.490 *
L(INV)	-2.983	-2.834	ΔL(INV)	-6.341 *	-11.805 *
L(ASE)	1.450	0.906	ΔL(ASE)	-7.051 *	-14.063 *
L(LE)	1.600	2.431	ΔL(LE)	-5.268 *	-5.322 *
L(DCB)	-1.407	-1.550	ΔL(DCB)	-4.971 *	-4.995 *
CAD	0.150	-1.947	Δ(CAD)	-8.944 *	-9.494 *

* Indicates significance at 1% level, i.e., rejection of the hypothesis of no co-integration.

According to Granger (1986) and Engle and Granger (1987) if the series are individually stationary after differencing but a linear combination of their levels is stationary then the series are said to be cointegrated. Co-integration means existence of a long run equilibrium relationship among the variables which can be tested by applying the multivariate vector error correction (VEC) techniques of Johansen (1988) and Johansen and Juselius (1990). We apply this method with assumptions of constant only and constant and trend in the time series and we use the trace statistics and the maximum Eigen value to establish co-integration. The tests indicate the existence of at least two co-integrating vectors as presented in Table 2.

Table 2. Co-integration test results.

H ₀	Intercept			Intercept and Trend		
	Eigen Value	Trace Statistic	Max-Eigen Statistic	Eigen Value	Trace Statistic	Max-Eigen Statistic
r = 0	0.744	226.663 *	58.573 *	0.899	288.297 *	98.529 *
r ≤ 1	0.711	168.090 *	53.412 *	0.713	189.768 *	53.649 *
r ≤ 2	0.562	114.678 *	35.470	0.591	136.119 *	38.430
r ≤ 3	0.503	79.207 *	30.038	0.504	97.689 *	30.120
r ≤ 4	0.435	49.169 *	24.526	0.435	67.569 *	24.526
r ≤ 5	0.275	24.643	13.817	0.401	43.043 *	22.023
r ≤ 6	0.185	10.826	8.784	0.248	21.020	12.235
r ≤ 7	0.046	2.042	2.042	0.185	8.784	8.784

Note: * denotes rejection of the null hypothesis at the 0.05 level.

Thus, a long run equilibrium relationship between resource rents, human capital and economic growth in Sudan is established.

3.3. VECM Specification and Estimation

Based on the results of the order of integration and co-integration, a VECM corresponding to Equation (1) is specified as follows:

$$\begin{aligned}
 \Delta L(GDP)_{t-i} &= \beta_0 + \alpha_1 L(GDP)_{t-1} + \alpha_2 L(TRR)_{t-1} + \alpha_3 L(DEY)_{t-1} + \alpha_4 L(INV)_{t-1} \\
 &+ \alpha_5 L(ASE)_{t-1} + \alpha_6 L(LE)_{t-1} + \alpha_7 L(DCB)_{t-1} + \alpha_8 CAD_{t-1} + \beta_1 \sum_{j=1}^{k-1} \Delta L(GDP)_{t-j} \\
 &+ \beta_2 \sum_{j=1}^{k-1} \Delta L(TRR)_{t-j} + \beta_3 \sum_{j=1}^{k-1} \Delta L(DEY)_{t-j} + \beta_4 \sum_{j=1}^{k-1} \Delta L(INV)_{t-j} + \beta_5 \sum_{j=1}^{k-1} \Delta L(ASE)_{t-j} \\
 &+ \beta_6 \sum_{j=1}^{k-1} \Delta L(LE)_{t-j} + \beta_7 \sum_{j=1}^{k-1} \Delta L(DCB)_{t-j} + \beta_8 \sum_{j=1}^{k-1} \Delta(CAD)_{t-j} + \sum ECT_t + \varepsilon_t
 \end{aligned} \tag{2}$$

The parameters $\alpha_1, \alpha_2, \alpha_3, \alpha_4, \alpha_5, \alpha_6, \alpha_7,$ and α_8 are the long run equilibrium coefficients associated with GDP, TRR, DEY, INV, ASE, LE, DCB and CAD respectively. The parameters $\beta_1, \beta_2, \beta_3, \beta_4, \beta_5, \beta_6, \beta_7$ and β_8 are their corresponding short run dynamic coefficients. ECT is the error correction term and ε_t is the white noise random term. The VECM is estimated with a lag length of 2 selected according to LR criterion as presented in Table 3.

Table 3. VAR lag order selection criteria.

Lag	LL	LR	FPE	AIC	SC	HQ
0	-378.620	NA	0.009	17.982	18.310	18.103
1	-97.867	443.981	3.92×10^{-7} *	7.901	10.850 *	8.988 *
2	-27.967	84.531 *	4.08×10^{-7}	7.626	13.197	9.681
3	38.105	55.316	9.74×10^{-7}	7.530 *	15.722	10.551

* indicates lag order selected by the criterion; LR: sequential modified LR test statistic (each test at 5% level); FPE: Final prediction error; AIC: Akaike information criterion; SC: Schwarz information criterion; HQ: Hannan-Quinn information criterion.

The estimated VECM results are summarized in Table 4 and represented by Equation (3).

Table 4. Summary results of the VECM.

VECM Short Run Dynamics				VECM Long Run Equilibrium		
Variable	Coefficient β	T. Stat.	Prob.	Variable	Coefficient α	T. Stat.
ECT _{t-1}	-0.58	-3.761	0.000 ***	L(GDP) _{t-1}	1.00	
dL(GDP) _{t-1}	0.33	1.616	0.108	L(TRR) _{t-1}	-0.03	-1.250
dL(GDP) _{t-2}	0.52	2.874	0.005 **	L(DEY) _{t-1}	0.35	4.452 ***
dL(TRR) _{t-1}	0.07	2.435	0.016 **	L(INV) _{t-1}	0.22	1.967
dL(TRR) _{t-2}	0.08	2.360	0.019 **	L(ASE) _{t-1}	-1.39	-2.176 *
dL(DEY) _{t-1}	0.12	2.149	0.033 **	L(LE) _{t-1}	-8.75	-2.635 **
dL(DEY) _{t-2}	0.12	1.700	0.091 *	L(DCB) _{t-1}	-0.36	-8.071 ***
dL(INV) _{t-1}	-0.04	-0.454	0.650	CAD _{t-1}	-0.00	-0.246
dL(INV) _{t-2}	-0.07	-0.753	0.452	C	29.90	
dL(ASE) _{t-1}	-0.51	-1.113	0.267			
dL(ASE) _{t-2}	0.62	1.466	0.144			
dL(LE) _{t-1}	-31.71	-3.212	0.002 ***			
dL(LE) _{t-2}	-1.15	-0.130	0.897			
dL(DCB) _{t-1}	0.07	0.458	0.647			
dL(DCB) _{t-2}	0.07	0.420	0.675			
d(CAD) _{t-1}	-0.00	-1.061	0.230			
d(CAD) _{t-2}	-0.00	-1.010	0.314			
C	0.13	2.145	0.033 **			

-2
 $R^2 = 0.68; R = 0.45; SER = 0.143; SSR = 0.513; F. stat. = 3.06; LL = 34.20; AIC = -0.753; SC = -0.016;$
 Durbin-Watson (DW) = 2.11

Diagnosis Tests		
Test Statistic	Prob.	
Autocorrelation	126.98	0.314
Heteroskedasticity	1242.96	0.347
Normality	55.80	0.000
Stability	VECM imposes 7 units, none is out the unit root circle	

***, ** and * indicate significance at 1%, 5% and 10% level respectively.

The estimated VEC model is represented by Equation (3).

$$\begin{aligned}
 dL(GDP) = & -0.58L(GDP)_{t-1} - 0.03L(TRR)_{t-1} + 0.35L(DEY)_{t-1} \\
 & + 0.22L(INV)_{t-1} - 1.39L(ASE)_{t-1} - 8.75L(LE) - 0.36L(DCB)_{t-1} \\
 & - 0.00(CAD) + 0.33dL(GDP)_{t-1} + 0.52dL(GDP)_{t-2} + 0.07dL(TRR)_{t-1} \\
 & + 0.08dL(TRR)_{t-2} + 0.12dL(DEY)_{t-1} + 0.12dL(DEY)_{t-2} - 0.04dL(INV)_{t-1} \\
 & - 0.07dL(INV)_{t-2} + 0.51dL(ASE)_{t-1} + 0.62dL(ASE)_{t-2} - 31.71dL(LE)_{t-1} \\
 & - 1.15dL(LE)_{t-2} + 0.07dL(DCB)_{t-1} + 0.07dL(DCB)_{t-2} - 0.00(CAD)_{t-1} - 0.00(CAD)_{t-2} + 0.13
 \end{aligned}
 \tag{3}$$

From the diagnostic test statistics presented in Table 4, the VECM passes all necessary robustness tests.

The VECM estimates show that the positive effect of resource rents on economic growth in the short run (a coefficient of 0.07) is overwhelmingly outweighed by a negative effect of life expectancy at birth on economic growth (a coefficient of -31.71). In the long run, the direct effect of resource rents on economic growth turns to be negative combined with negative effects of school enrolment, life expectancy at birth and financial development. The positive effect of development expenditure is far less than to offset these negative effects on economic growth.

Table 5 presents the short Granger causality test results. The test shows the existence of a bidirectional relationship between GDP and TRR. The short run causality from resource rents to GDP is positive, thus ruling out existence of RC directly. Now we turn to the effect of TRR on the explanatory variables in our model. The test shows that the causality between TRR and DEY is negative in both directions although insignificant. TRR is found to negatively cause education but not significantly, while TRR is found to be highly positively and significantly causing life expectancy at birth. As far as transmission of the effect of resource rent is concerned, we found a negative causal relationship from education to GDP growth, but positive from GDP growth to education, although none of them is significant. Although the short run causality from TRR to LE is significantly positive, we find a negative and significant causality from life expectancy to GDP growth. Meanwhile, GDP is found to be positively causing life expectancy. Current account deficit is found to be the variable least dynamically affected by resource rents and by other variables.

Table 5. VECM Granger causality based test results.

Variable	Short Run Dynamics							Long Run	
	dL(GDP)	dL(TRR)	dL(DEY)	dL(INV)	dL(ASE)	dL(LE)	dL(DCB)	d(CAD)	ECT _{t-1}
dL(GDP) _{t-1}		-2.80 (-2.124) *	-0.50 (-0.730)	-0.66 (-1.557)	0.03 (0.298)	0.01 (1.822) *	0.05 (0.172)	-157.53 (-0.096)	-0.58 **
dL(TRR) _{t-1}	0.07 (2.435) *		-0.08 (-0.829)	-0.03 (-0.491)	-0.01 (-0.795)	0.001 (2.381) *	-0.01 (-0.159)	51.18 (0.213)	-0.03 *
dL(DEY) _{t-1}	0.12 (2.149) *	-0.10 (-0.270)		-0.18 (-1.462)	0.05 (1.979) *	-0.0003 (-0.301)	0.02 (0.267)	172.87 (0.372)	0.35
dL(INV) _{t-1}	-0.04 (-0.454)	-0.22 (-0.412)	-0.03 (-0.094)		-0.05 (-1.517)	-0.001 (-0.894)	-0.16 (-1.250)	-403.20 (-0.599)	0.22 *
dL(ASE) _{t-1}	-0.51 (-1.113)	-2.04 (-0.687)	-1.28 (-0.829)	-0.48 (-0.500)		0.02 (2.138) *	1.24 (1.759)	-2658.86 (-0.722)	-1.39 *
dL(LE) _{t-1}	-31.71 (-3.212) **	142.01 (2.222) *	21.10 (0.632)	-2.14 (-0.104)	2.56 (0.624)		11.36 (0.750)	-10149.78 (-0.128)	-8.75 **
dL(DCB) _{t-1}	0.07 (0.458)	1.00 (1.057)	0.17 (0.336)	-0.62 (-2.042) *	0.03 (0.505)	0.004 (1.682)		-1158.73 (-0.986)	-0.36 **
d(CAD) _{t-1}	-0.00 (-1.061)	0.00 (0.913)	0.00 (0.424)	0.00 (0.222)	0.00 (0.014)	0.00 (0.318)	0.00 (1.067)		0.00

Note: **, * indicate significance at 1% and 5% respectively.

Based on Table 5, we extract and summarize the direct and indirect effects of resource rents on economic growth to identify existence of a resource curse as presented in Table 6.

Table 6. Direct and indirect effects of TRR on economic growth.

Causality	β	Signif.	Causality	β	Signif.	Remark
TRR→GDP	0.07	(2.435) *	TRR→GDP	0.07	(2.435) *	Positive from TRR to GDP, no RC
TRR→DEY	-0.08	(-0.829)	DEY→GDP	0.12	(2.149) *	Negative from TRR to DEY but Positive from DEY to GDP, no RC
TRR→INV	-0.03	(-0.491)	INV→GDP	-0.04	(-0.454)	Negative from TRR to INV and Negative from INV to GDP, RC
TRR→ASE	-0.01	(-0.795)	ASE→GDP	-0.51	(-1.113)	Negative from TRR to ASE and Negative from ASE to GDP, RC
TRR→LE	0.001	(2.381) *	LE→GDP	-31.71	(-3.212) **	Positive from TRR to LE, but Negative from LE to GDP, RC
TRR→DCB	-0.01	(-0.159)	DCB→GDP	0.07	(0.458)	Negative from TRR to DCB but Positive from DCB to GDP, no RC
TRR→CAD	51.18	(0.213)	CAD→GDP	-0.00	(-1.061)	Positive from TRR to CAB but Negative from CAB to GDP, RC

Note: RC indicates existence of resource curse; ** and * indicate significance at 1% and 5% respectively.

As in Tables 5 and 6, while the effect of TRR on development expenditure is found to be negative, but the transmitted effect from development expenditure to GDP and is found to be positive and significant. This means that that development expenditure which is mainly financed by foreign borrowing affects GDP growth positively and significantly regardless of whether resource rents are used to finance such expenditure. The effect of TRR on investment is negative and transmitted into a negative effect on economic growth, but both of them are not significant. This indicates that resource rents were not effectively converted into productive physical capital. The effect of TRR on school enrollment is negative and transmits into a negative effect on economic growth. This result is partly in line with Mosquera (2019) who finds that resource boom affects educational attainment negatively in Ecuador after the oil discovery in 1973. Although the effect of TRR on life expectancy is found to be to be positive, the transmitted effect from life expectancy to economic growth is found to be negative, sizable and significant. Collectively, these results are in line with other studies which find that resource abundance crowd out physical and human capital formation. The effect of TRR on financial development is found to be negative but transmitted into positive effect on economic growth, although not significantly. The effect of TRR on current account deficit is positive, but the transmitted effect from the current account deficit to GDP is negative. The negative effect of current account deficit on GDP growth was also confirmed in Elwasila Saeed Elamin (2017b). These results imply that resource rent does not cause resource curse directly but indirectly mainly through health in terms of life expectancy at birth, followed by school enrollment and investment. The results also suggest that government policies have not been supportive for creating a virtuous economic circle in managing the resource rents. Granger non-causality or exogeneity of variables is also tested through the Wald test in order to judge which variables lead and which lag the others. Only GDP and life expectancy at birth are found to be lagging and the other variables of interest including resource rents are found to be leading (highly significantly exogenous), bearing the process of adjustments. The results also indicate that GDP is mostly affected by and affects life expectancy at birth on the one hand and GDP growth is affected by all other variables rather than affecting them as presented in Table 7.

Table 7. Granger causality/block Exogeneity Wald test results.

Dependent Variable	Chi-sq	DF	Prob.	Decision
L(GDP) L(TRR), L(DEY), L(INV), L(ASE), L(LE), L(DCB), CAD	41.73	14	0.000 **	Reject
L(TRR) L(GDP), L(DEY), L(INV), L(ASE), L(LE), L(DCB), CAD	15.83	14	0.324	Accept
L(DEY) L(GDP), TRR, L(INV), L(ASE), L(LE), L(DCB), CAD	9.09	14	0.825	Accept
L(INV) L(GDP), L(TRR), L(DEY), L(ASE), L(LE), L(DCB), CAD	18.31	14	0.193	Accept
L(ASE) L(GDP), L(TRR), L(DEY), L(INV), L(LE), L(DCB), CAD	19.39	14	0.150	Accept
L(LE) L(GDP), (TRR), L(DEY), L(INV), L(ASE), L(DCB), CAD	25.57	14	0.029 *	Reject
L(DCB) L(GDP), L(TRR), L(DEY), L(INV), L(ASE), L(LE), CAD	11.45	14	0.650	Accept
(CAD) L(GDP), L(TRR), L(DEY), L(INV), L(ASE), L(DCB) L(LE)	4.46	14	0.992	Accept

** and * indicate significance at 1% and 5% level respectively.

Long run Granger causality test results as reported in Table 8 show a unidirectional causal relationship running from TRR to GDP. DEY, ASE, LE, and DCB are found to cause GDP, with no sign of feedback from these input variables to GDP growth. These results indicate non-existence of a reverse causality from GDP to the model's explanatory variables. As long as the indirect effect of TRR on economic growth is concerned, we investigated the long run causality between the explanatory variables of our model. The test reveals that resource rents negatively cause education and life expectancy at birth, and current account deficit. This suggests human and foreign capitals have been running down in Sudan. Investment is found to be led by school enrolment and financial development. Existence of a bidirectional causal relationship between school enrollment and life expectancy indicates that human capital components are augmented by one another. However, with insufficient government spending on health and education people are left to themselves to spend on education and health of their children, a fact that is seen in large and increasing private spending on health and education as percentage of total spending. These results also point out that Sudan is far behind on any path to social finance transition.

Table 8. Long run Granger causality results.

	F-Stat.	Prob.	Decision	Direction of Causality
H₀: Dependent GDP				
H ₀ : L(TRR) does not cause L(GDP)	2.868	0.069 *	Reject	TRR to GDP
H ₀ : L(GDP) does not cause L(TRR)	0.292	0.748	Accept	None
H ₀ : L(DEY) does not cause L(GDP)	10.52	0.000 ***	Reject	DEY to GDP
H ₀ : L(GDP) does not cause L(DEY)	0.254	0.777	Accept	None
H ₀ : L(INV) does not cause L(GDP)	0.060	0.942	Accept	None
H ₀ : L(GDP) does not cause L(INV)	0.160	0.853	Accept	None
H ₀ : L(ASE) does not cause L(GDP)	4.662	0.015 **	Reject	ASE to GDP
H ₀ : L(GDP) does not cause L(ASE)	0.269	0.766	Accept	None
H ₀ : L(LE) does not cause L(GDP)	3.246	0.040 **	Reject	LE to GDP
H ₀ : L(GDP) does not cause L(LE)	1.533	0.229	Accept	None
H ₀ : L(DCB) does not cause L(GDP)	3.572	0.038 **	Reject	DCB to GDP
H ₀ : L(GDP) does not cause L(DCB)	1.261	0.295	Accept	None
H ₀ : CAD does not cause L(GDP)	1.391	0.261	Accept	None
H ₀ : L(GDP) does not cause CAD	5.415	0.008 ***	Reject	None

Table 8. Cont.

	F-Stat.	Prob.	Decision	Direction of Causality
H₀: Independents				
H ₀ : L(TRR) does not cause L(ASE)	4.308	0.020 **	Reject	TRR to ASE
H ₀ : L(TRR) does not cause L(LE)	2.502	0.095 *	Reject	TRR to LE
H ₀ : L(TRR) does not cause CAD	4.882	0.013 ***	Reject	TRR to CAD
H ₀ : L(ASE) does not cause L(INV)	3.142	0.054 **	Reject	ASE to INV
H ₀ : L(DCB) does not cause L(INV)	3.603	0.037 **	Reject	DCB to INV
H ₀ : L(LE) does not cause L(ASE)	3.998	0.026 **	Reject	LE to ASE
H ₀ : L(ASE) does not cause L(LE)	2.829	0.071 *	Reject	ASE to LE
H ₀ : L(ASE) does not cause CAD	10.445	0.000 ***	Reject	ASE to CAD
H ₀ : L(LE) does not cause CAD	6.356	0.004 ***	Reject	LE to CAD

***, ** and * indicates significance at 1%, 5% and 10% level respectively.

4. Discussions and Conclusions

This study aimed at investigating the effects of resource rents on economic growth in the presence education and life expectancy at birth as proxies of human development in Sudan—a case of a single developing country. Descriptive statistical analysis reveals that while resource rents were growing faster and steadily since 1998, GDP has been growing at a slower pace and is highly volatile, suggesting a resource curse. Furthermore, over the period 1992–2012, we found that resource rents were trending up faster than development expenditure and domestic credit provided by banks, while investment as a percentage of GDP has been steadily declining. This suggests that resource rents were not converted into productive assets, which resulted in the slow pace of economic growth. Empirically, using conventional econometric time series methods, namely VECM with annual data covering the period of 1970–2015, the study finds evidences that natural resource rents inflict negative effects on long run economic growth. In fact, a positive effect of resource rents in the short run turns out to be negative and larger in the long run. Importantly, resources rents seem to crowd out investment in health and education in Sudan and the effect of resource rents on economic growth is indirectly mediated through human development. Specifically, the indirect negative effect of resource rents on economic growth is found to be mediated by a negative effect of rents on school enrollment and more evidently by sizable and significant negative effects on life expectancy, particularly in the long run. While resource rents tend to deter development expenditure, the transmitted effect from development expenditure to GDP is found to be positive and significant. This amounts to arguing that development expenditure enhances economic growth regardless of the effect of resource rents. A negative effect of resource rents on gross investment is also transmitted into a negative effect on economic growth. Both financial development and current account deficit have significant negative effects on economic growth. These results indicate that resource rents were not effectively converted into productive human, physical and financial capitals. As a matter of calculation, the short run direct positive effect of resource rents on economic growth (a coefficient of 0.07) is found to be overwhelmingly eroded by the negative effect of health on economic growth (a coefficient of -31.71). More importantly, in the long run the direct negative effect of resource rents on economic growth in the long run (a coefficient of -0.03) is aggravated by negative effects of school enrolment, life expectancy and financial development (a combined coefficient of 10.50). Thus, our results contradict Papyrakis and Gerlagh (2004) who, in a panel data study, find that the natural resources have a negative impact on growth when considered in isolation, but a positive impact on growth when schooling is included. Our results also indicate that education plays important role on whether a country is blessed or cursed by resource abundance, and thus contradicts, in part, Maty (2012). Long run Granger causality test results confirm that total resource rents negatively cause GDP, while development expenditure positively causes GDP growth. Both education and life expectancy at birth are found to cause GDP growth but with no feedback effect from GDP growth to either education or health. Such results suggest that the government has been neglecting quantity and quality investments in human capital in the presence of resource rents. Put

collectively, natural resource rents have been negatively affecting economic growth in Sudan mainly through their negative interaction with human capital. Thus, our results in part do not confirm [Elwasila Saeed Elamin \(2017a\)](#) who found a positive relationship between health and economic growth in Sudan, when considered in isolation of resource rents. Also, our results contradict [Arabi and Abdalla \(2013\)](#) who found that school attainment and health have positive and significant effects on economic growth in Sudan. However, our results are in line with [Akpan and Chuku \(2014\)](#) who found the negative effect of resource abundance on human capital accumulation in Nigeria through the channels of the DD and crowding out of human capital effects. Our results also confirm [Amin et al. \(2017\)](#) who found negative effect of resource rents on health and education in resource-rich SSA. Yet, our results partially confirm [Oyinlola et al. \(2019\)](#) on the negative indirect effect of education but contradict their finding of a positive indirect effect of health in their study of 17 SSA.

Overall, our empirical results from the case of Sudan suggest government policy was designed and implemented away from proper management of resource wealth, accumulation and re-investment of rents in productive human, physical and financial capitals. It is well established that all these capitals are necessary for sustainable growth in resource rich developing countries. Large revenues and rents from such resources might have induced the government to spend in populous projects without consideration of the effectiveness and efficiency of such projects, favoring military and security spending round point resources such as oil fields. Oil and gold resources have been overly contested between the governments and rebel groups in Sudan. On the other hand, successive governments in Sudan have been clearly neglecting spending on education and health. Large resource revenues and rents also worsen the level of corruption, especially where the rule of law and accountability are weak. Sudan has wasted an opportunity to make the appropriate use of resources rents for investing in productive human and physical capitals which are necessary for building a virtuous economic circle of resource utilization. If well managed, resource rents could have generated benefits to a large portion of population and made economic growth more equitable and inclusive. The apparent limitation of the study pertains to the omission of some conventional variables on the analysis of the RC. But in our case this is justified by: (i) non-availability of time series data on variables such institutional quality, rule of law, corruption, war and conflicts; (ii) these omitted variables are well embodied and reflected in the performance of how resources and rents are managed, and human capital formation is neglected in government decisions and policies; and (iii) the literature has already established that bad government policies, bad institutions, lack of rule of law, corruption, war and conflicts make natural resources a curse rather than a blessing in developing countries. It is a fact that institutions and rule of law in Sudan are bad, and can only be expected to aggravate the negative findings of the relationships between resource rents, human capital and economic growth if data permit their explicit inclusion in any growth regression. Also, Sudan is a country of armed conflicts since its independence in 1956, with unstable government regimes, mostly military with just a few years of immature democracy. In such an environment, successive governments, particularly since 1990, have been using natural resource revenues and rents with priorities given to military and security spending at the expense of spending on health and education. Aside from the role of institutions, [Sachs and Warner \(2001\)](#) conclude that there is little direct evidence that omitted geographical or climate variables explain the curse, or that there is a bias resulting from some other unobserved growth deterrent.

To conclude, for Sudan and other similar resource-rich countries there is no way to avoid the resource curse without proper and transparent resource wealth management policies. Priorities should be given to proper and sufficient spending on education and health, and even with sub-priorities in these sectors, for example primary education versus tertiary education and preventive versus curative health care services. If such policies are set and put in operation, they would reduce poverty and enhance inclusive economic growth.

Funding: This research received no external funding.

Conflicts of Interest: The author declares no conflict of interest.

References

- Akpan, Godwin, and Chuku Chuku. 2014. Natural Resources, Human Capital and Economic Development in Nigeria: Tracing the Linkages. *Journal of Economics and Sustainable Development* 5: 44–50.
- Alexeev, Michael, and Robert Conrad. 2009. The elusive curse of oil. *The Review of Economics and Statistics* 91: 586–98. [CrossRef]
- Amin, Karimo, George Adu, George Marbuah, Justice Tei Mensah, and Franklin Amuakwa-Mensah. 2017. Natural Resource Revenues and Public Investment in Resource-Rich Economies in Sub-Saharan Africa. *Review of Development Economics* 21. [CrossRef]
- Apergis, Nicholas, and James E. Payne. 2014. The oil curse, institutional quality, and growth in MENA countries: Evidence from time-varying cointegration panel. *Energy Economics* 46: 1–9. [CrossRef]
- Arabi, Khalafalla Ahmed Mohamed, and Suliman Zakaria Abdalla. 2013. The Impact of Human Capital on Economic Growth: Empirical Evidence from Sudan. *Research in World Economy* 4. [CrossRef]
- Arrow, Kenneth J., Partha Dasgupta, Lawrence Goulder, Keven Muford, and Kristen Oleson. 2012. Sustainability and the measurement of wealth. *Environment and Development Economics* 17: 317–53. [CrossRef]
- Ascher, William. 1999. *Why Governments Waste Natural Resources: Policy Failure in Developing Countries*. Baltimore: Johns Hopkins University Press.
- Auty, Richard M. 1993. *Sustaining Development in Mineral Economies: The Resource Curse Thesis*. London and New York: Routledge.
- Auty, Richard M., ed. 2001a. *Resource Abundance and Economic Development*. Oxford and New York: Oxford University Press.
- Auty, Richard M. 2001b. The Political Economy of Resource-Driven Growth. *European Economic Review* 45: 839–46. [CrossRef]
- Auty, Richard M. 2010. Elites, rent cycling and development: Adjustment to land scarcity in Mauritius, Kenya and Cote d'Ivoire. *Development Policy Review* 28: 411–33. [CrossRef]
- Auty, Richard M., and Kiiski Sampsa. 2001. Natural Resources, Capital Accumulation, Structural Changes and Welfare. In *Resource Abundance and Economic Development*. Edited by Auty Richard M. Oxford: Oxford University Press.
- Bakwena, Malebogo, Philip Bodman, Thanh Le, and Ki Kam Tang. 2009. Avoiding the Resource Curse: The Role of Institutions. No 3209, Macroeconomics Research Group MRG Discussion Paper Series; Discussion Paper No. 32. School of Economics. Australia: University of Queensland. Available online: <http://www.uq.edu.au/economics/mrg/3209.pdf> (accessed on 16 June 2016).
- Barro, Robert J. 1996. *Health, Human Capital and Economic Growth*. Paper for the Program on Public Policy and Health, Pan American Health Organization and World Health Organization. Washington, DC: Pan American Health Organization.
- Barro, Robert J. 2013. Health and Economic Growth. *Annals of Economics and Finance* 14: 305–42.
- Barro, Robert J., and Jong-Wha Lee. 1994. Sources of Economic Growth. *Carnegie-Rochester Conference Series on Public Policy* 40: 1–46. [CrossRef]
- Beck, Thorsten. 2011. *Finance and Oil: Is there a Resource Curse in Financial Development?* Discussion Paper 2011-017. Tilburg: Tilburg University, Center for Economic Research.
- Beck, Thorten, and Poelhekke Steven. 2017. *Follow the Money: Does the Financial Sector Intermediate Natural Resource Windfalls?* Center for Economic Studies & Ifo Institute for Economic Research CESIFO Working Paper No. 6374. Available online: https://www.cesifo.org/DocDL/cesifo1_wp6374.pdf (accessed on 18 August 2019).
- Bhattacharyya, Sambit, and Paul Collier. 2013. Public Capital in Resource Rich Economies: Is there a Curse? *Oxford Economic Papers* 66: 1–24. [CrossRef]
- Birdsall, Nancy, Thomas Pinckney, and Richard Sabot. 2001. Natural Resources, Human Capital and Growth. In *Resource Abundance and Economic Development*. Edited by Auty Richard M. Oxford: Oxford University Press, pp. 57–75.
- Bloom, David, David Canning, and Jaypee Sevilla. 2004. The effects of health on economic growth: A production function approach. *World Development* 32: 1–13. [CrossRef]
- Boschini, Anne, Pettersson Jan, and Jesper Roine. 2013. The resource curse and its potential reversal. *World Development* 43: 19–41. [CrossRef]

- Brunnschweiler, Christa N. 2008. Cursing the blessings? Natural resources, institutions and economic growth. *World Development* 36: 399–419. [CrossRef]
- Brunnschweiler, Christa N., and Erwin Bulte. 2008. The resource curse revisited and revised: A tale of paradoxes and red herrings. *Journal of Environmental Economics and Management* 55: 248–64. [CrossRef]
- Bulte, Erwin, Richard Damania, and Robert Deacon. 2005. Resource Intensity, Institutions, and Development. *World Development* 33: 1029–44. [CrossRef]
- Cockx, Lara, and Natahlie Francken. 2014. Extending the concept of the resource curse: Natural resources and public spending on health. *Ecological Economics* 108: 136–49. [CrossRef]
- Cockx, Lara, and Natahlie Francken. 2015. Is there a Natural Resource Curse on Education Spending? Working Paper 2015.02. Institute of Development Policy and Management. Available online: <http://www.uantwerp.be/job> (accessed on 17 August 2017).
- Collier, Paul, and Anke Hoeffler. 2004. Greed and Grievance in Civil War. *Oxford Economic Papers* 56: 563–95. [CrossRef]
- Collier, Paul, and Anke Hoeffler. 1998. On Economic Causes of Civil War. *Oxford Economic Papers* 50: 563–73. [CrossRef]
- Constantinos, Alexiou, Persefoni Tsaliki, and Hashim Osman Rasha. 2014. Institutional Quality and Economic Growth: Empirical Evidence from the Sudanese Economy. *Economic Annals* 59: 119–37. [CrossRef]
- Corden, W. M. 1984. *Booming Sector and Dutch Disease Economics: Survey and Consolidation*. Oxford Economic Papers, New Series; Oxford: Oxford University Press, vol. 36, pp. 359–80.
- Corden, W. M., and J.P. Neary. 1982. Booming Sector and De-industrialization in Small Open Economy. *The Economic Journal* 92: 825–48. [CrossRef]
- Daly, Herman. 1994. Operationalizing Sustainable Development by Investing in Natural Capital. In *Investing in Natural Capital: The Ecological Economics Approach to Sustainability*. Edited by A.-M. Jansson, M. Hammer, C. Folke and R. Costanza. Washington, DC: Island Press, pp. 22–37.
- Daniel, Philip, Gupta Sanjeev, Todd Amttina, and Alex Segura-Ubierno. 2013. Extracting Resource Revenues. *Finance & Development* 50: 19–22.
- Daniele, Vittorio. 2011. Natural Resources and the ‘quality’ of economic development. *The Journal of Development Studies* 47: 545–73. [CrossRef]
- Davis, Graham A., and John E. Tilton. 2005. The resource curse. *Natural Resources Forum* 29: 233–42. [CrossRef]
- Deacon, Robert T., and Rode Ashwin. 2012. *Rent Seeking and the Resource Curse*. Santa Barbara: University of California, Available online: <http://econ.ucsb.edu/~rdeacon/RentSeekingResourceCurse%20Sept%202026.pdf> (accessed on 20 March 2016).
- Dickey, David A., and Wayne A. Fuller. 1981. Likelihood Ratio Statistics for Autoregressive Time Series with Unit Roots. *Econometrica* 49: 1057–72. [CrossRef]
- Dietz, Simon, Erik Neumayer, and Indra De Soysa. 2007. Corruption, the resource curse and genuine saving. *Environment and Development Economics* 12: 33–53. [CrossRef]
- Elbadawi, Ibrahim Ahmed, and Raimundo Soto. 2015. Resource rents, institutions, and violent civil conflicts. *Defense and Peace Economics* 26: 89–113. [CrossRef]
- Elwasila Saeed Elamin, Mohamed. 2017a. Resource gaps, foreign capital flows and economic growth in Sudan: An empirical econometric analysis. *African Journal of Economic and Sustainable Development* 6: 292–316.
- Elwasila Saeed Elamin, Mohamed. 2017b. Health and economic growth in Sudan: Cointegration and Granger causality analysis (1969–2015). *Turkish Economic Review* 5: 192–205.
- Engle, Robert F., and Clive W. J. Granger. 1987. Co-integration and Error Correction: Representation, Estimation, and Testing. *Econometrica* 55: 251–76. [CrossRef]
- Frankel, Jeffery A. 2012. *The Natural Resource Curse: A Survey*. NBER Working Paper No. 15836. Cambridge: National Bureau of Economic Research, Available online: https://www.nber.org/system/files/working_papers/w15836/w15836.pdf (accessed on 18 August 2017).
- Gelb, Alan, and Sina Grasmann. 2010. *How Should Oil Exporters Spend Their Rents?* CGD Working Paper No. 221. Washington, DC: Center for Global Development.
- Granger, Clive W. J. 1986. Developments in the Study of Cointegrated Economic Variables. *Oxford Bulletin of Economics and Statistics* 48: 213–28. [CrossRef]
- Granger, Clive W. J., and Paul Newbold. 1974. Spurious Regressions in Economics. *Journal of Econometrics* 2: 111–20. [CrossRef]

- Gylfason, Thorvaldur, Herbertsson Thor Tryggvi, and Gylfi Zoega. 1999. A mixed blessing: Natural resources and economic growth. *Macroeconomic Dynamics* 3: 204–225. [CrossRef]
- Gylfason, Thorvaldur, and Gylfi Zoega. 2003. Inequality and economic growth: Do natural resources matter. In *Inequality and Economic Growth: Theory and Policy*. Edited by T. Eicher and S. Turnovsky. Cambridge: MIT Press.
- Gylfason, Thorvaldur, and Gylfi Zoega. 2006. Natural resources and economic growth: The role of investment. *The World Economy* 29: 1091–115. [CrossRef]
- Gylfason, Thorvaldur. 2001a. Natural Resources and Economic Growth: What is the Connection? Center for Economic Studies & Ifo Institute for Economic Research CESIFO Working Paper No. 530. Available online: www.cesifo.de (accessed on 17 March 2016).
- Gylfason, Thorvaldur. 2001b. Natural resources, education, and economic development. *European Economic Review* 45: 847–859. [CrossRef]
- Hamilton, Kirk, Giovanni Ruta, and Tajibaeva Liaila. 2006. Capital Accumulation and Resource Depletion: A Hartwick Rule Counterfactual. *Environmental and Resource Economics* 34: 517–33. [CrossRef]
- Hamilton, Kirk, and Michael Clemens. 1999. Genuine Savings Rates in Developing Countries. *The World Bank Economic Review* 13: 333–56. [CrossRef]
- Hamilton, Kirk. 2001. The Sustainability of Extractive Economies. In *Resource Abundance and Economic Development*. Edited by Auty Richard M. Oxford: Oxford University Press, pp. 36–56.
- Hartwick, John. 1977. Intergenerational Equity and Investing Rents from Exhaustible Resources. *The American Economic Review* 66: 972–74.
- Havranek, Thomas, Roman Horvath, and Ayaz Zeynalov. 2016. Natural Resources and Economic Growth: A Meta-Analysis. IES Working Paper 03/2016. Charles University. Available online: <http://ies.fsv.cuni.cz> (accessed on 20 July 2020).
- Havro, Gøril, and Javier Santiso. 2008. *To Benefit from Plenty: Lessons from Chile and Norway*; Policy Brief No. 37. Paris: OECD Development Centre, OECD. Available online: <https://www.oecd.org/dev/41281577.pdf> (accessed on 12 October 2017).
- Ibrahim, Dolapo Raheem, Kazeem Ovanreo Isah, and Abdulfatai A. Adedeji. 2018. Inclusive growth, human capital development and natural resource rent in SSA. *Economic Change and Restructuring* 51: 29–48.
- Isham, Jonathan, Woolcock Michael, Lant Pritchett, and Gwen Busby. 2005. The Varieties of Resource Experience: Natural Resource Export Structures and the Political Economy of Economic Growth. *The World Bank Economic Review* 19: 141–74. [CrossRef]
- Johansen, Søren, and Katarina Juselius. 1990. Maximum Likelihood Estimation and Inference on cointegration with Applications to Demand for Money. *Oxford Bulletin of Economics and Statistics* 52: 169–210. [CrossRef]
- Johansen, Søren. 1988. Statistical analysis of cointegration vectors. *Journal of Economic Dynamics and Control* 12: 231–54. [CrossRef]
- Karl, Terry Lynn. 1997. *The Paradox of Plenty: Oil Booms and Petro-States*. Berkeley: University of California Press.
- Keikha, Alireza, Ahmadali Keikha, and Mohsen Mehrara. 2012. Institutional Quality, Economic Growth and Fluctuations of Oil Prices in Oil Dependent Countries: A Panel Cointegration Approach. *Modern Economy* 3: 218–22. [CrossRef]
- Kim, Dong-Hyeon, and Shu-Chin Lin. 2016. Human Capital and Natural Resource Dependence. *Structural Change and Economic Dynamics* 40: 92–102. [CrossRef]
- Kurtz, Marcus, and Sara Brooks. 2011. Conditioning the “Resource Curse”: Globalization, Human Capital, and Growth in Oil-Rich Nations. *Comparative Political Studies* 44: 747–70. [CrossRef]
- Lederman, Daniel, and William F. Maloney. 2008. In Search of the Missing Resource Curse. World Bank Policy Research Working Paper 4766. Available online: <http://ideas.repec.org/p/wbk/wbrwps/4766.html> (accessed on 28 August 2017).
- Leite, Carlos, and Jens Weidmann. 1999. *Does Mother Nature Corrupt? Natural Resources, Corruption, and Economic Growth*. IMF Working Paper No. 99/85. Washington, DC: International Monetary Fund, Available online: <https://www.imf.org/external/pubs/ft/wp/1999/wp9985.pdf> (accessed on 26 August 2016).
- Lundgren, Charlotte, Alun Thomas, and Robert York. 2013. *Boom, Bust, or Prosperity? Managing Sub-Saharan Africa's Natural Resource Wealth*. Washington, DC: International Monetary Fund, Available online: <https://www.imf.org/external/pubs/ft/dp/2013/dp1302.pdf> (accessed on 18 August 2017).

- Maty, Konte. 2012. A Curse or a Blessing? Natural Resources in a Multiple Growth Regimes Analysis. Available online: <https://halshs.archives-ouvertes.fr/halshs-00793217> (accessed on 20 September 2018).
- Mehlum, Halvor, Moene, Karl Ove, and Torvik Ragnar. 2006. Institutions and the Resource Curse. *The Economic Journal* 116: 1–20. [CrossRef]
- Mehlum, Halvor, Moene, Karl Ove, and Torvik Ragnar. 2011. *Mineral Rents and Social Development in Norway*. Memorandum, No. 14/2011. Oslo: University of Oslo, Department of Economics.
- Mehrara, Mohsen, and Baghbanpour Javad. 2015. Analysis of the Relationship between Total Natural Resources Rent and Economic Growth: The Case of Iran and MENA Countries. *International Journal of Applied Economic Studies* 3: 1–7. Available online: <http://sijournals.com/IJAE/> (accessed on 17 July 2018).
- Mejía, Andrés Acosta. 2012. *Using Natural Resource Revenues for Education. Background Paper Prepared for the Education for All Global Monitoring Report 2012*. Youth and Skills: Putting Education to Work 2012/ED/EFA/MRT/PI/09. Paris: United Nations Educational, Scientific and Cultural Organization, UNESCO Publishing.
- Ministry of Finance and National Economy. 2000–2013. *Annual Economic Reports, Issues 2000 to 2013*, Khartoum, Sudan; Khartoum: Ministry of Finance and National Economy.
- Mosquera, Roberto. 2019. *A Blessing or a Curse? The Long-Term Effect of Resource Booms on Human Capital*. (August 2019). Available online: <http://dx.doi.org/10.2139/ssrn.3364717> (accessed on 25 December 2019).
- Natural Resource Governance Institute. 2017. Resource Governance Index. Available online: www.resourcegovernanceindex.org (accessed on 11 December 2018).
- Neumayer, Erik. 2004. Does the “Resource Curse” hold for Growth in Genuine Income as Well? *World Development* 32: 1627–40. [CrossRef]
- Nour, Samia. 2010. *Assessment of Science and Technology Indicator in Sudan*. United Nation University UNU-MERIT Working Paper Series; Maastricht: United Nation University.
- Oyinlola, Mutiu, Abdulfatai Adedeji, and Modupe Bolarinwa. 2019. Exploring the nexus among natural resource rents, human capital and industrial development in the SSA region. *Economic Change and Restructuring* 53: 87–111. [CrossRef]
- Papayrakis, Elissaios, and Reyer Gerlagh. 2004. The resource curse hypothesis and its transmission channels. *Journal of Comparative Economics* 32: 181–93. [CrossRef]
- Papayrakis, Elissaios, and Reyer Gerlagh. 2007. Resource Abundance and Economic Growth in the United States. *European Economic Review* 51: 1011–39. [CrossRef]
- Peretto, F. Peitro. 2008. Is the “Curse of Natural Resources” really a Curse? Duke University ERID Working Paper Number 14. The Social Science Research Network Electronic Paper Collection. Available online: <http://ssrn.com/abstract=1270606> (accessed on 20 March 2019).
- Phillips, Peter, and Pierre Perron. 1988. Testing for a Unit Root in Time Series Regression. *Biometrika* 75: 335–446. [CrossRef]
- Pineda, Jose, and Francisco Rodriguez. 2010. *Curse or Blessing? Natural Resources and Human Development*. Human Development Research Paper 2010/04. New York: UNDP.
- Romer, Paul. 1990. *Human Capital and Growth: Theory and Evidence*. NBER Working Paper No. 3173. Cambridge: National Bureau of Economic Research, Available online: <http://papers.nber.org/papers/w3173> (accessed on 20 November 2016).
- Ross, L. Michael. 2001. Does oil hinder democracy? *World Politics* 53: 325–61. [CrossRef]
- Sabine, Fuss, Claudine Chen, Michael Jacob, Marxen Annika, Desirazu Roa Narasimha, and Ottmar Edenhofer. 2016. Could resource rents finance universal access to infrastructure? A first exploration of needs and rents. *Environment and Development Economics* 21: 691–712. [CrossRef]
- Sachs, Jeffery, and Andrew Warner. 1995. *Natural Resource Abundance and Economic Growth*; NBER Working Paper No. 5398. Cambridge: National Bureau of Economic Research. Available online: <http://papers.nber.org/papers/w5398> (accessed on 20 November 2016).
- Sachs, Jeffery, and Andrew Warner. 1997a. Sources of slow growth in African economies. *Journal of African Economies* 6: 335–76. [CrossRef]
- Sachs, Jeffery, and Andrew Warner. 1997b. Fundamental sources of long-run growth. *The American Economic Review* 87: 184–88.
- Sachs, Jeffery, and Andrew Warner. 2001. The curse of natural resources. *European Economic Review* 45: 827–38. [CrossRef]

- Sandonato, Silvana, and Henry Willebald. 2018. Natural Capital, Domestic Product and Proximate Causes of Economic Growth: Uruguay in the Long Run, 1870–2014. *Sustainability* 10: 715. [CrossRef]
- Santos, Rafael J. 2018. Blessing and curse. The gold boom and local development in Colombia. *World Development* 106: 337–55. [CrossRef]
- Sarr, Marre, and Katarina Wick. 2010. Resources, conflict and development choices: Public good provision in resource rich economies. *Economics of Governance* 11: 183–205. [CrossRef]
- Selim, Hodaand, and Chahir Zaki. 2014. *The Institutional Curse of Natural Resources in the Arab World*. Economic Research Forum Working Paper 890. Cairo: Economic Research Forum.
- Sen, Amartya. 1988. The Concept of Economic Development. In *Handbook of Development Economics*. Edited by Hollis Chenery and T. N. Srinivasan. Amsterdam: Elsevier, vol. 1, pp. 9–26.
- Shao, Shuai, and Lilli Yang. 2014. Natural resource dependence, human capital accumulation, and economic growth: A combined explanation for the resource curse and the resource blessing. *Energy Policy* 74: 632–42. [CrossRef]
- Stern, David. 2003. Energy and Economic Growth. *Resources Policy* 30: 107–30.
- Stevens, Paul, Glada Lahn, and Kooroshy Jaakko. 2015. The Resource Curse Revisited. Research Paper, Energy, Environment and Resources. The Royal Institute of International Affairs, Chatham House London. Available online: www.chathamhouse.org (accessed on 23 July 2017).
- Stijns, Jean-Philippe. 2005. Natural resource abundance and economic growth revisited. *Resources Policy* 30: 107–30. [CrossRef]
- Stijns, Jean-Philippe. 2006. Natural resource abundance and human capital accumulation. *World Development* 34: 1060–83. [CrossRef]
- van der Ploeg, Frederick, and Steven Poelhekke. 2009. Volatility and the resource curse. *Oxford Economic Papers* 61: 727–60. [CrossRef]
- van der Ploeg, Fredrick. 2011. Natural resources: Curse or blessing? *Journal of Economic Literature* 49: 366–420. [CrossRef]
- Venables, Anthony J. 2016. Using Natural Resources for Development: Why Has It Proven So Difficult? *Journal of Economic Perspectives* 30: 161–84. [CrossRef]
- Warner, Andrew. 2015. *Natural Resource Booms in the Modern Era: Is the Curse still Alive?* IMF Working Paper WP/15/237. Washington, DC: International Monetary Fund.
- Weil, N. David. 2005. *Accounting for the Effect of Health on Economic Growth*. NBER Working Paper No. 5398. Cambridge: National Bureau of Economic Research, Available online: <http://citeseerx.ist.psu.edu/viewdoc/summary?doi=10.1.1.216.7536> (accessed on 20 November 2015).
- Wick, Katharina, and Butle Erwin. 2006. Contesting resources—Rent seeking, conflict and the natural resource curse. *Public Choice* 128: 457–76. [CrossRef]
- World Bank. 2011. *The Changing Wealth of Nations: Measuring Sustainable Development in the New Millennium*. Washington, DC: World Bank. Washington, DC: World Bank.
- World Bank. 2017a. *World Development Indicators*. Washington, DC: World Bank.
- World Bank. 2017b. *World Governance Indicators*. Washington, DC: World Bank.
- Zhang, Dayong. 2008. Oil shock and economic growth in Japan: A nonlinear approach. *Energy Economics* 30: 2374–90. [CrossRef]

Publisher's Note: MDPI stays neutral with regard to jurisdictional claims in published maps and institutional affiliations.



© 2020 by the author. Licensee MDPI, Basel, Switzerland. This article is an open access article distributed under the terms and conditions of the Creative Commons Attribution (CC BY) license (<http://creativecommons.org/licenses/by/4.0/>).

Article

Mobility Restrictions and E-Commerce: Holistic Balance in Madrid Centre during COVID-19 Lockdown

Rafael Villa ^{1,*} and Andrés Monzón ²¹ School of Technology and Science, Camilo José Cela University, 28692 Madrid, Spain² Transport Research Centre (TRANSyT), Universidad Politécnica de Madrid, 28040 Madrid, Spain; andres.monzon@upm.es

* Correspondence: rvilla@ucjc.edu

Abstract: COVID-19 has brought about a substantial change in urban mobility, as well as an unprecedented increase in e-commerce throughout the world due to the emergence of new ways of shopping and consumption habits. In this context, urban logistics plays a crucial role in the triple bottom line of sustainability. The present document establishes a holistic vision of the problem aiming to (i) measure and compare the traffic generated in the Madrid Central area (low-emission zone) during the periods before and after the pandemic, and (ii) quantify e-commerce orders made by residents, as well as the Light Commercial Vehicles (LCV) required to deliver these parcels, measuring their environmental impact. The results show that road traffic in the Madrid Central area decreased by approximately 2/3 compared to normal levels and 1/2 in the case of LCVs. With regards to e-commerce, the number of parcels delivered doubled. This fact entailed an increase in the number of LCVs dedicated to package delivery in the central district and more pollution, but to a lesser extent than the growth of e-commerce. The challenge faced by urban logistics in the post-Covid era is managing to blend new mobility within large cities with the high volumes of e-commerce deliveries demanded by residents.

Citation: Villa, Rafael, and Andrés Monzón. 2021. Mobility Restrictions and E-Commerce: Holistic Balance in Madrid Centre during COVID-19 Lockdown. *Economics* 9: 57. <https://doi.org/10.3390/economics9020057>

Academic Editor: George Halkos

Received: 23 February 2021

Accepted: 9 April 2021

Published: 13 April 2021

Publisher's Note: MDPI stays neutral with regard to jurisdictional claims in published maps and institutional affiliations.



Copyright: © 2021 by the authors. Licensee MDPI, Basel, Switzerland. This article is an open access article distributed under the terms and conditions of the Creative Commons Attribution (CC BY) license (<https://creativecommons.org/licenses/by/4.0/>).

Keywords: city logistics; last-mile delivery; sustainable development; e-commerce; COVID-19; environmental economics; sustainable transport

1. Introduction

Habitability, sustainability and competitiveness; these are the main challenges faced by large cities throughout the world. Their prioritization translates into improved quality of life for inhabitants and facilitates development from the three perspectives of sustainability: economic, social and environmental. There is a clear consensus among the main stakeholders of smart cities that human welfare and needs should be the starting point for a city's development, always taking into account sustainability criteria.

According to the European Commission ([European Commission 2021](#)), the large majority of European citizens live in an urban environment, and over 60% live in urban areas with over 10,000 inhabitants. Urban mobility accounts for 40% of all road transport CO₂ emissions and up to 70% of other transport contaminants. In cities like Rome (166), Paris (165) and London (149), traffic congestion causes residents to lose a significant number of hours on the road ([INRIX 2020](#)). The challenge for local administrations lies in reducing this traffic congestion in order to improve the habitability and competitiveness of their cities ([Demir et al. 2015](#)).

Within the context of urban goods distribution, globalization and e-commerce have generated exponential growth in road transport by enabling the development of an open market where products can be purchased from any location. Goods travel throughout the world and most are delivered in cities. This effect has been compounded by the COVID-19 crisis, as consumers have had to adopt new ways of shopping and new consumption habits, leading to an increase in the percentage of users who purchase physical products online. The number of trucks and vans is increasing due to the rising popularity of e-commerce

and the desire for faster deliveries (Savelsbergh and Woensel 2016), which, in turn, has led to more frequent and split deliveries in residential areas.

This increase in the number of transport vehicles in cities translates directly into greater congestion and accidents (social), more air pollution and noise (environmental) and higher logistics costs, with a subsequent increase of product prices (economic). Each city has attempted to implement its own solutions, resulting in initiatives that have generally been suboptimal at addressing this triple balance (Macharis and Melo 2011). In late 2020, the European Commission presented a sustainable and smart mobility strategy (European Commission 2020) which defined a roadmap of 82 initiatives grouped into three main pillars: digitalization, resilience and greening of mobility, in terms of both individuals and goods. This includes an exhaustive set of measures for goods transport, including weight reduction in road transport, the definition of specific plans to achieve sustainable urban logistics, and greater use of intermodal transport, favoring the use of railways and waterways, both inside and outside cities.

In order to tackle this challenge, cities must face the difficult task of promoting systems of urban goods distribution that are environmentally friendly as well as sufficiently efficient to satisfy both society and logistics businesses. It is important to highlight that sustainable development objectives can be pursued through measures that are occasionally contradictory and generate a different impact based on the affected stakeholders (Gatta and Marcucci 2014). The new challenge for city logistics lies in finding solutions that are capable of absorbing an increase in urban transport of goods derived from new consumption patterns while, at the same time, minimizing the associated social and environmental impact.

Accepting the radical changes that the emergence of COVID-19 has brought to our society in most fields, the present document aims to compare the pandemic's repercussions on traffic, e-commerce and urban logistics in the central district of the City of Madrid (Madrid Central area). More specifically, we aim to answer the following questions:

- What has been the impact on city traffic of the mobility restrictions imposed due to COVID-19?
- How has the demand for e-commerce parcels evolved before and after the pandemic?
- What have been the implications of this increase in e-commerce for urban logistics and the environment?

2. Literature Review

2.1. Urban Logistics: Context, E-Commerce and and Measures in New Scenario

2.1.1. Urban Movement of Goods

The movement of urban goods is essential for economic vitality (Allen et al. 2000; Muñuzuri et al. 2005) and key for industrial, commercial and leisure activities which, in turn, are vital in wealth generation. Following the ideas presented by various authors (International Conference on City Logistics et al. 2004; González-Feliu et al. 2012; Cattaruzza et al. 2017), the movement of goods within cities can be grouped into three main categories: (i) movement between businesses -B2B-, movement to end consumers -B2C- and urban management movement. Figure 1 shows these types of movements of goods and their main organization modalities.

Of total urban traffic, the distribution of urban goods is responsible for approximately 15% on a typical city (Dablanc 2011). Moreover, it involves other activities requiring greater use of space in cities: loading-unloading, storage, etc. Within urban logistics, different studies in French cities have determined that 46% of the total urban movement of goods is related to B2C commerce (Cattaruzza et al. 2017).

This paper addresses the transport of goods related to B2C commerce (ECM), specifically, urban logistics derived from e-commerce.

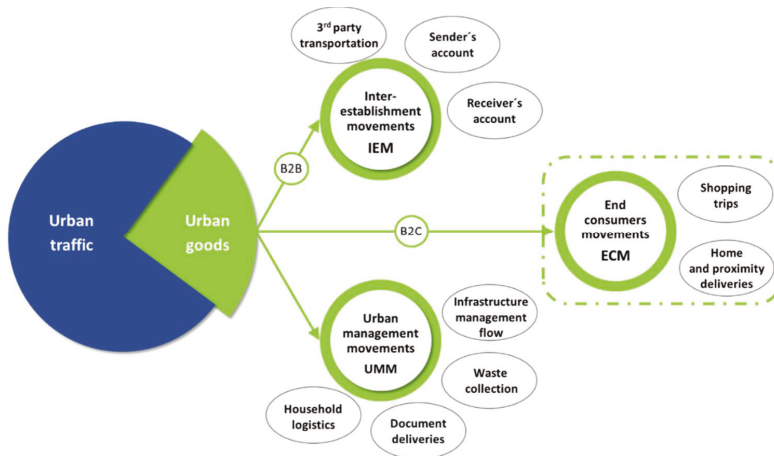

Figure 1. Classification of urban goods movement. Source: adapted from (Cattaruzza et al. 2017).

2.1.2. E-Commerce and Urban Logistics

Today, urban consumers can purchase everything they need online. In early 2020, the global population stood close to 7.75 billion inhabitants, of which 4.54 billion had used the Internet at least once, representing a penetration of 59%. Within the group of Internet users, 74% had made an online purchase during the studied period (We Are Social and Hootsuite 2021).

This continued growth of e-commerce throughout the world has accelerated in 2021, as COVID-19 has rewritten the rules of the retail sector. Between January 2019 and June 2020, retail platforms experienced an extraordinary increase in global traffic. The websites of retail businesses received nearly 22 billion visits in June 2020; a 35.5% increase year-on-year (Statista 2020a). In the United States, the share of e-commerce in total retail sales rose from 11.8 to 16.1% between the first and second quarters, and in the United Kingdom from 20.3 to 31.3%. In the EU-27, retail sales via mail order houses or the Internet in April 2020 increased by 30% compared to April 2019, while total retail sales diminished by 17.9% (OECD 2020a).

The reasons are evident: lockdown measures have driven new consumers to pursue online channel in order to avoid busy physical stores, and the shopping frequency of previous cyber-customers has increased and a multitude of businesses which did not yet have an online presence have launched such initiatives. E-commerce has become the only feasible option for many traditional brick-and-mortar stores during the pandemic, and has demonstrated its resilience by meeting growing consumer demand and ensuring the provision of essential goods and services, e.g., by posting products on social media sites and ordering product pick-up or delivery services (Koch et al. 2020; E-Commerce Europe 2021). However, the effect of the COVID-19 crisis on e-commerce has not been uniform across product categories or sellers. While the impact of COVID-19 on several categories has been considerable, it has had a much smaller impact on other products. Items related to food, fashion, electronics, beauty and household were the best-selling products, while others, such as tourism and airlines, have collapsed (OECD 2020b).

Amidst the unstoppable growth of e-commerce, while electronic transactions travel through data networks, the physical products being purchased still need to be transported and delivered to end consumers. During the first months of the pandemic, transportation and distribution of goods became one of the main causes of disruptions in the supply chain and affected the supply of essential items (Ivanov 2020; Linton and Vakil 2020). More people living in cities and simpler transactions for consumers translate into a higher frequency of deliveries and more vehicles on the road (Crainic et al. 2004;

Cardenas et al. 2017). This increase in e-commerce has resulted in increased pressure on last-mile logistics (Srinivas and Marathe 2021).

In addition, the on-demand economy and its instant deliveries have driven new consumer habits (Dablanc et al. 2017), where q-commerce (quick-commerce) has emerged as a new model within e-commerce, based on speed, convenience and customer care. Users value fast deliveries, being able to choose among different delivery options and being kept informed about the status of their orders. Regarding the evolution experienced by commerce in cities, Figure 2 shows the key characteristics of various generations of B2C commerce. Four new characteristics related to urban distribution are added to those previously established by Delivery Hero: Quick Commerce: Pioneering the Next Generation of Delivery (2020).

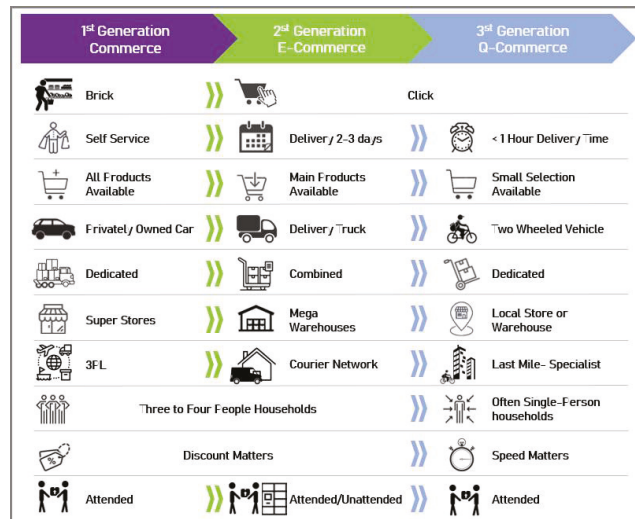

Figure 2. The evolution of quick commerce. Source: adapted from (Delivery Hero: Quick Commerce: Pioneering the Next Generation of Delivery 2020).

Figure 2 shows the evolution of consumer purchasing habits and the response by logistics operators to satisfy this demand. In the first generation of commerce, customers were the ones who visited physical stores, with a large product offering, to make their purchases. In q-commerce, purchases take place through a click, delivery time is a key variable and the product range is limited, since there are numerous online stores.

The logistics response to these shopping habits is very different. The first scenario deals with large volumes, employs large warehouses, optimizes loads and its essential element is cost. On the other hand, q-commerce volumes are small, operates through microhubs, response time is the key consideration and has couriers specializing in last-mile operations.

Q-commerce accentuates the difficulties already faced by e-commerce urban distribution: small volumes, more delivery addresses, higher resupply frequencies, lower stock levels, reduced optimization of vehicle loads and just-in-time deliveries (Lebeau and Macharis 2014). All of these elements entail an increasing dependence on urban roads and a need to find solutions for urban logistics. In this new context, lockers, collection points and mobile warehouses can have a positive impact from various perspectives and for all stakeholders involved in urban logistics by reducing the number of trips, failed deliveries and vehicles required. (Viu-Roig and Alvarez-Palau 2020).

2.1.3. Measures and Solutions to Improve Urban Logistics

In recent years, numerous initiatives have sought to minimize the negative effects of urban distribution and create the basis for a more solid and circular future economy where resources are employed more sustainably.

Different authors have classified and organized the significant number of measures proposed to improve city logistics into various categories (Russo and Comi 2011; Browne et al. 2012; Stathopoulos et al. 2012; CIVITAS 2015; Macharis and Kin 2017; Ranieri et al. 2018). However, the literature has mainly focused on the perspective of local authorities and political decision makers, despite the key role played by the private sector in many of these measures. Macharis and Kin (2017) focus on measures which explicitly include responsible stakeholders acting in city logistics. They classify these measures according to the so-called “four As”: (i) awareness, (ii) avoidance, (iii) acting and (iv) anticipation of new technologies (see Table 1).

Table 1. Measures and solutions to improve urban logistics.

Type of Measure	Measure	Examples	
Public intervention measures	Regulatory measures	Temporary access restrictions	Delivery restrictions during the day Silent deliveries at night
		Parking regulations	Loading and unloading restrictions Vehicle parking reservation systems Shared time in parking spaces
		Environmental restrictions	Emissions standards and restrictions related to motors Noise programs/regulations Low emission areas
		Access restrictions by size or load	Weight restrictions Vehicle size Load factor restrictions
	Market-based measures	Pricing (tolls, congestion tariffs and parking fees)	Road use tolls Congestion tariffs Parking fees
		Taxes, tax breaks and incentives	High taxes for polluting vehicles Subsidies for purchase of electric vehicles Tax exemptions for electric vehicles
		Negotiable permits and mobility credits	Purchase and sale of load transport services Mobility credits in city centers
	Infrastructure and land use	Adaptation of street loading/unloading areas	Providing space on pavement for parking and loading activities
		Building codes and construction regulations	New commercial premises providing adequate space for goods handling
		Nearby delivery areas	Providing loading areas at public or private parking, empty areas, etc.
Initiatives by urban logistics stakeholders	Technological innovation measures	Innovation in vehicles	Electric vehicles Unmanned vehicles: drones and terrestrial autonomous vehicles
		Delivery points	Mailboxes for parcels Smart lockers Collection points
	Collaboration in urban logistics	Advanced algorithms and optimization	Integrated inventory management Task-courier matching Route optimization Data-driven demand forecast
		Order or load capacity exchange Collaborative local deliveries Collaborative storage Collaborative load sending	
	Infrastructure and logistics systems	Urban infrastructure and logistics installations	Urban distribution centers Microhubs Consolidation of multiple operators
		Urban logistics systems	Systems for underground transport of goods Deliveries through public transport Night distribution

Source: own elaboration, based on (CIVITAS 2015; Macharis and Kin 2017; Ranieri et al. 2018).

These measures and initiatives are listed below, grouped into two main perspectives:

- Public intervention measures:
 - (a) Regulatory measures.
 - (b) Market-based measures.
 - (c) Infrastructure and land use planning
- Initiatives from players participating in urban logistics:
 - (d) Technological innovation measures
 - (e) Infrastructure and logistics systems

Therefore, there is no single solution for urban logistics; all measures work as levers that must be applied based on the characteristics and circumstances of each particular city and taking into account the interests of all stakeholders.

The remainder of this document is structured as follows: Section 3 describes the methodology used in the research. Sections 4 and 5 present the case study and results of the methodology for the Madrid Central area. Section 6 discusses the results and, lastly, Section 7 presents the conclusions and possible areas for further research.

3. Methodological Framework

To address the objectives described, the research is developed from two connected perspectives. First, from the descriptive side, traffic in the Madrid Central area is measured before and after COVID-19. Second, the effects of the pandemic on e-commerce are estimated, along with the impact on urban distribution of goods. The whole procedure is shown in Figure 3.

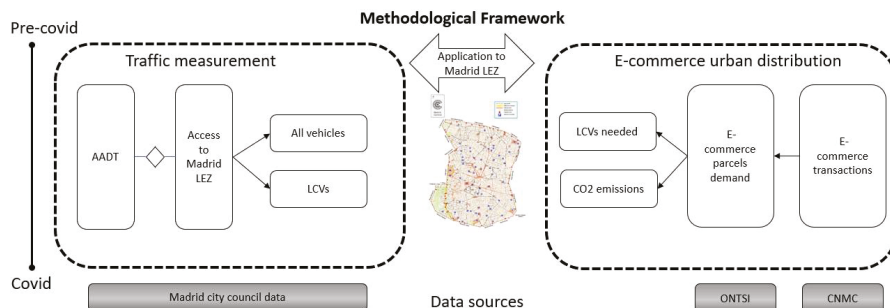

Figure 3. Methodological framework.

The first step was to measure the Annual Average Daily Traffic (AADT) and number of vehicles that accessed the Madrid Central area during the analyzed periods. The calculation of AADT was based on the information collected daily by City of Madrid through electromagnetic coils embedded into the pavement, which constantly quantify the passage of vehicles, thus enabling monitoring of traffic conditions in a given stretch of road. The measurement of vehicles accessing the Madrid Central area was based on data received from cameras placed on access points to monitor any registration plates entering it. The City of Madrid has installed 115 of these cameras to track vehicle access.

The second step consisted in analyzing the evolution of e-commerce in the studied periods through changes in consumption behaviors caused by the outbreak of COVID-19. The data was obtained from Spain's National Authority for Markets and Competition (CNMC). Quarterly e-commerce statistics take into consideration e-commerce (business volume and number of transactions) carried out using bank payment cards corresponding to the collaborating Spanish payment entity: Sistema de Tarjetas y Medios de Pago S.A. The products considered in this research are goods purchased through e-commerce and requiring physical distribution.

In the case of the Madrid Central area, the calculation of demand for e-commerce parcels considered home delivery as the most feasible and commonly used option. The calculation of this potential daily demand for e-commerce parcels was estimated through the chain-ratio method proposed by [Kotler and Keller \(2012\)](#), which multiplies a base number by several adjusting percentages to estimate the target demand.

The formulation would be as follows:

$$\begin{aligned} &\text{Daily demand for ecommerce parcels by residents} \\ (D) &= A \times P1 \times P2 \times P3 \times P4 \times P5 \end{aligned} \quad (1)$$

where:

A = residents over 16 years of age

P1 = % average of residents over 16 years of age who use the Internet

P2 = % average of residents over 16 years of age who use the Internet and shop online

P4 = % average of residents over 16 years of age who use the Internet and shop online daily

P5 = % average of residents over 16 years of age who use the Internet and shop online daily for products that are physically delivered

Resident data were obtained from City of Madrid public data repository, whereas data related to e-commerce came from the National Observatory for Telecommunications and the Information Society ([ONTSI 2020](#)), through its report “B2C e-commerce in Spain in 2019”.

Lastly, once the number of online transactions had been defined, the next step was to calculate the vehicles required to deliver those orders, taking into account both the number of courier companies and the theoretical load of light commercial vehicles (LCV). The market share of each courier was obtained from the CNMC through its annual report on the evolution of the postal sector ([CNMC 2019](#)).

Likewise, the CO₂ emissions generated by last-mile e-commerce deliveries were estimated for the two periods analyzed. The calculation of emissions took into account previous estimations of CO₂ emissions per kilometer travelled. The reference value to calculate emissions is kgCO₂ per km, following data from the [International Post Corporation \(2018\)](#), [DPDgroup \(2019\)](#) and [Deloitte \(2020\)](#).

4. Case Study

Madrid is the largest city in Spain and the second largest in the European Union, with a population of 3,266,126. It is the core of Madrid Region, which has 6,663,394 inhabitants (Spanish Statistics Institute, [INE 2020a](#)).

Moreover, the Madrid Region has the highest GDP per capita in Spain and tenth highest in Europe, at over 35,000 euros per person in 2019 ([INE 2020b](#)). It is the seat of the main public institutions in the country and region, as well as the hub for political-administrative, financial and commercial activity. There are over 520,000 businesses in the region (16% of the country’s total), but when narrowing the scope to those with over 500 employees, the percentage increases up to 40%.

Currently, the City of Madrid is divided into 21 administrative districts which, in turn, are comprised by 131 neighborhoods. Six of them form the Madrid Central area (see [Figure 4](#)), where we focused this research and which also make up the oldest part of the city. This area has a total surface of 523.73 ha and a population of 140,473 inhabitants as of 1 January 2020.

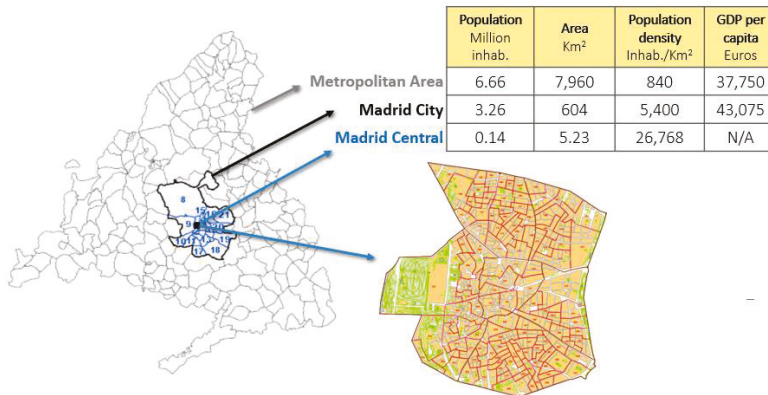

Figure 4. Region of Madrid, City of Madrid, and Madrid Central (adapted from City of Madrid website).

4.1. Urban Transport

Urban transport in the City of Madrid, of both passengers and goods, has been identified as one of the most complicated among large European cities due to the orography and historical evolution of its urban structure. In terms of urban morphology, the City of Madrid presents an irregular and radio-centric map, with narrow streets and closed construction plans combined with large squares and regular avenues created by the successive remodeling undergone by the city since the 16th century.

Regarding traffic and urban distribution, Madrid's vehicle pool has a high percentage of diesel vehicles as well as older models, with an average age of 9.3 years (Área de Gobierno de Medioambiente y Movilidad 2019). According to the Inventory of Atmospheric Pollutant Gas Emissions (Madrid City Council Environment and Mobility Office 2019), road transport accounted for 34.1% of total greenhouse gas (GHG) emissions. In late 2018, commercial and industrial vehicles older than 10 years represented 73.2% of the total (ANFAC 2019).

In Madrid, congestion related to urban logistics reached 38% (18 points more than in the rest of Spanish cities) and has been forecasted to rise up to 47% by 2025 (Madrid College of Economists 2020).

4.2. Madrid Central Area (Madrid LEZ)

A study analyzing 858 European cities concluded that the metropolitan section of Madrid was the urban area with the highest mortality related to nitrogen dioxide (NO₂) pollution in the continent. The study by ISGlobal (Khomenko et al. 2021) calculated that if all the analyzed cities reduced their concentrations of fine particles and NO₂ pollution to the levels recommended by the World Health Organization (WHO), they would prevent 51,000 premature deaths attributed to the former and 900 attributed to the latter.

In November of 2018, the City of Madrid defined a low-emission zone (LEZ) or "Madrid Central". This measure, known as "Madrid 360" since 2020, restricts the access of private vehicles to the central district of the capital in an effort to promote pedestrian mobility, bicycles and public transport. The only vehicles allowed are those belonging to residents, individuals with reduced mobility and security and emergency services. Logistics and distribution vehicles are allowed access to the 472 ha, but have been given a deadline to modernize their fleets.

The Madrid Central area is the core of the LEZ. Access regulations only allow eco-friendly vehicles with "0 Emissions" and "ECO" stickers, i.e., hybrid and electric vehicles, to drive and park in the area. Other vehicles can only access it if they are residents or to park in public parking or private garages.

5. Results

5.1. Calculation of Vehicle Traffic and Access to the Central District

Figures 5 and 6 show (i) traffic intensity and (ii) vehicle access to Madrid Central area for January–June in 2019 and 2020 (before and after COVID-19). The intensity, that is, the number of vehicles per hour, was registered at 177 measurement points distributed among the six neighborhoods of the Madrid Central area. Over 4,800,000 different measurements were recorded in all timeframes.

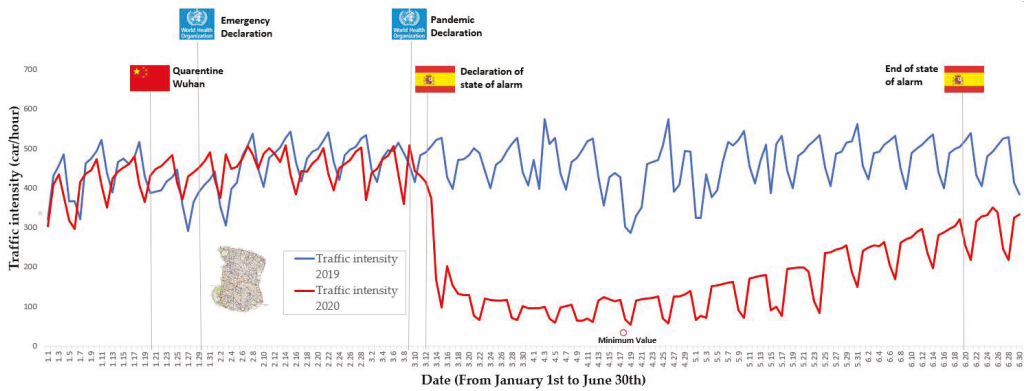

Figure 5. Traffic intensity 2019–2020 (Q1 and Q2: first and second quarter of the year).

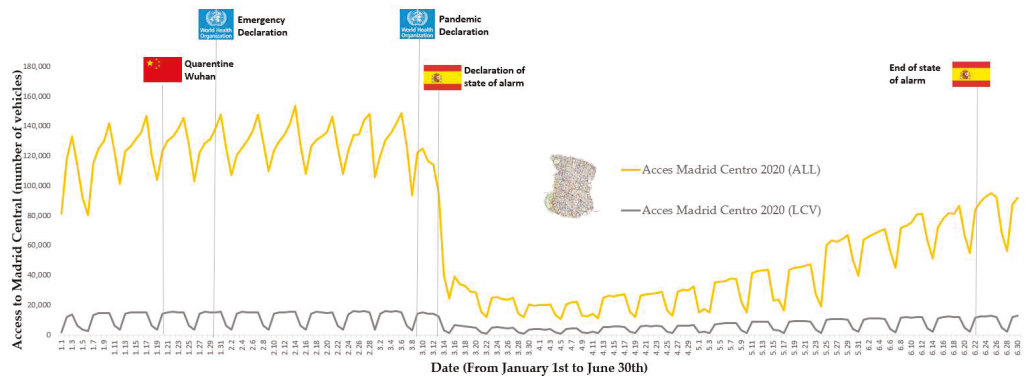

Figure 6. Vehicle access to the Madrid Central area in 2020 (Q1 and Q2).

As Figure 5 shows, the number of vehicles per hour was very similar during the first two months of both periods. The inflection point was 11 March, 2020, when the WHO declared a pandemic. Traffic intensity started to decrease considerably in the following days until, on 14 March, the Spanish Government declared a State of Alarm, limiting freedom of movement for citizens except for specific purposes and ordering most businesses to close, along with all leisure, education and cultural sites. On 15 March 2020, traffic intensity in the Madrid Central area was just 18.58% compared to the same day of the previous year.

Subsequently, in May 2020, traffic volume began to increase gradually until the end of June 2020. This increase corresponded to the progressive lifting of mobility restrictions in the City of Madrid. On 21 June, the State of Alarm was lifted, putting an end to the de-escalation process and bringing the country into the “new normal”. Nevertheless, on the last week of June, the “new normal” of 2020 saw 35.8% less traffic in the city center than on the same week of 2019.

Figure 7 shows vehicle access to the Madrid Central area during the analyzed periods (distinguishing access for all vehicles and for LCVs) and how the evolution was virtually the same as for traffic intensity. The correlation between traffic intensity and vehicle access (all vehicles) was 0.932 for 2019 and 0.995 for 2020. Regarding LCVs access, during 2019, this represented 9.72% out of the total vehicles accessing the Madrid Central area. This percentage remained similar during the pre-Covid period of 2020 (9.33%) and later increased up to 14.8% from 14 March to 30 June. In other words, the reduction in mobility in the Madrid Central area was more notable for other vehicles than for LCVs.

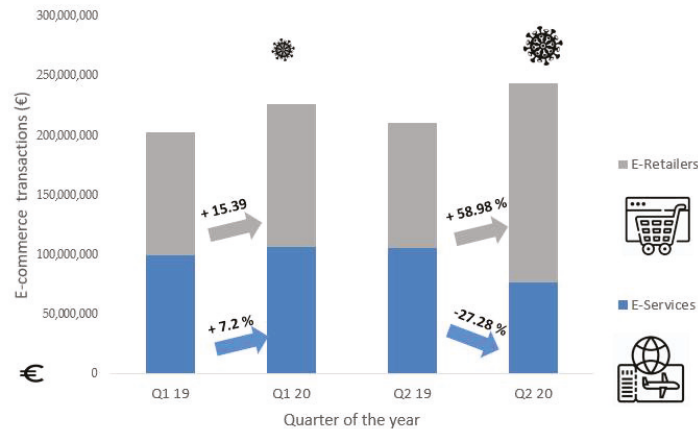

Figure 7. E-commerce transactions 2019–2020 (Q1 and Q2).

5.2. Calculation of E-Commerce Transactions for Physical Goods in Spain Pre- and Post-COVID

Concerning online sales, Figure 7 shows the volume of e-commerce transactions carried out by Spanish citizens throughout the analyzed period.

Focusing exclusively on e-retailers, or products requiring physical delivery, the increase in transactions reached 15.38% during the first quarter of 2020 (the last 15 days of this period correspond to the State of Alarm). In contrast, when comparing the second quarter of both years, the increase in physical goods purchased via e-commerce reached 58.97% during the first wave of the pandemic. Purchases at hypermarkets and supermarkets doubled and purchases of beverages, household appliances and audio-visual equipment tripled. Table 2 shows the 10 most popular product categories during the pandemic and their evolution throughout the 2014–2020 period. But not all sectors have experienced the same impact. Food, fashion, electronics, household products, beauty and parapharmacy have had remarkable growth while, for obvious reasons, tourism and airlines have been practically paralyzed.

Table 2. Top 10 e-commerce product categories with highest growth rates.

ACTIVITY	2014-2020 (Q2)	YOY Growth Rate (Q2: 2019-2020)
FURNITURE, LIGHTING AND HOME		318%
HOME APPLIANCES, VISUAL AND AUDIO PRODUCTS		310%
BEVERAGES		291%
TOYS AND SPORTS ITEMS		247%
HARDWARE, PAINTS AND GLASS		244%
OTHER NON-SPECIALIZED TRADE		243%
PERFUMERY, COSMETICS		224%
MEDICAL AND ORTHOPEDIC ITEMS		218%
HYPERMARKETS, SUPERMARKETS AND FOOD SHOPS		213%
BODY MAINTENANCE		203%

Source: own elaboration.

5.3. Calculation of Demand for E-Commerce Parcels

Figure 8 shows an estimation of the daily demand for e-commerce parcels for residents of the Madrid Central area. The estimate distinguishes total demand by quarter for the period from January 2019 to June 2020. As shown, while the order volume increased slightly during 2019, the number of parcels delivered in the central district exploded after the start of the pandemic, almost doubling in number.

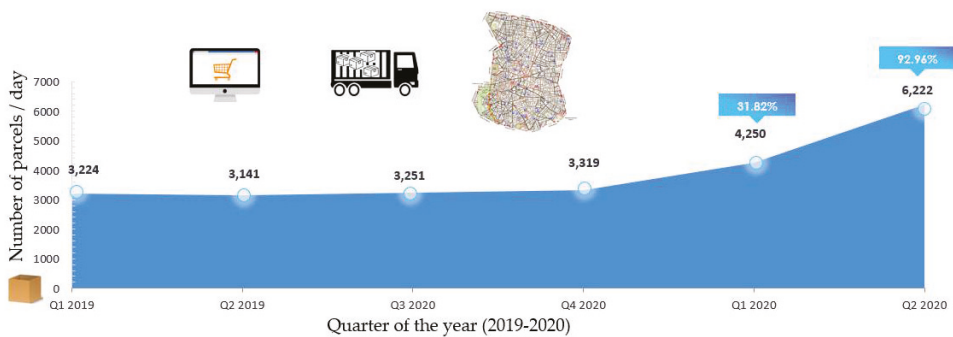

Figure 8. Daily online e-retail products 2019–2020.

As shown in Figure 9, the calculation of e-commerce demand begins with the total residents of the central district over 16 years of age and, applying the chain-ratio methodology, estimates the number of daily online shoppers for e-retailer products. The figure refers to Q1 2019.

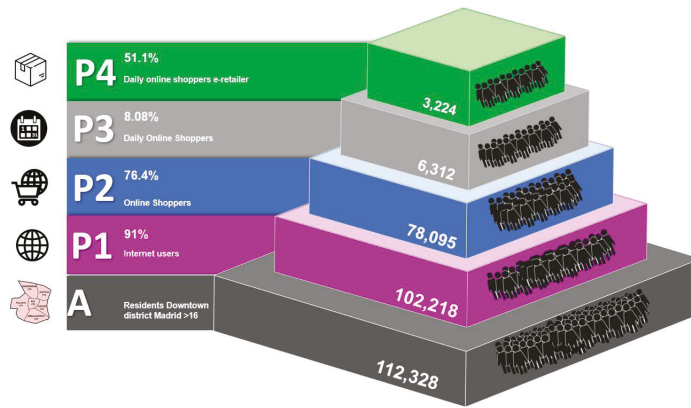

Figure 9. E-commerce factors explaining daily demand for residents.

5.4. Calculation of Delivery Van Fleet

The calculation of vans required to deliver e-commerce parcels takes into account current operations in last mile logistics in the City of Madrid. These follow the traditional scheme, with large sorting and delivery centers located in the outskirts, in towns like Coslada, San Fernando de Henares, etc. These are large-scale fulfilment centers handling significant volumes. From these warehouses, LCVs service the different urban centers through routes of approximately 80–120 km per day and vehicle, delivering 80–125 parcels each day throughout long delivery periods (Deloitte 2020). Higher traffic intensity entails lower values in this range whereas, with lower intensity (greater fluidity), couriers are able to deliver a larger number of parcels in each route.

Figure 10 represents express and parcel delivery market share, where 10 companies account for nearly 75% of the Spanish courier sector. The remaining 25% is divided among a large number of companies with a very small market share. Therefore, only companies dealing with significant volumes are able to optimize loads and routes simultaneously.

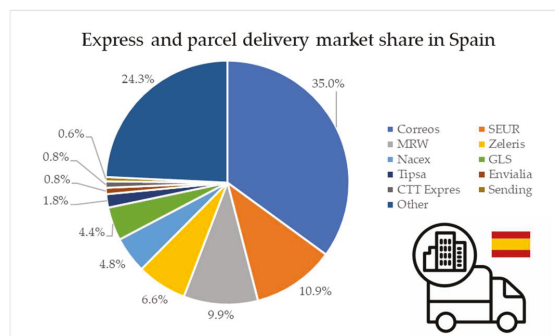

Figure 10. Market share: express and parcels delivery in Spain (source: CNMC 2020).

A larger number of couriers in the ecommerce market delivery brings down transport load optimization, since many operators will not have enough parcels to fully load their vans. In this scenario, they must either complete the route with less than their maximum capacity or combine it with other delivery areas.

Table 3 shows the minimum number of LCVs required to deliver the parcels requested by residents of the Madrid Central area, taking into account the market share of the courier sector and delivery productivity based on traffic (a value of 80–125 parcels/LCV is

considered following the traffic intensity explained in Appendix A). The figures represent daily data corresponding to the analysed period.

Table 3. Number of LCVs required to deliver parcels.

	Q1 2019	Q2 2019	Q1 2020	Q2 2020
Correos (35.0%)	15	14	17	18
SEUR (10.9%)	5	5	6	6
MRW (9.9%)	4	4	5	5
Zeleris (6.6%)	3	3	4	4
Nacex (4.8%)	2	2	3	3
GLS (4.4%)	2	2	3	3
Tipsa (1.8%)	1	1	1	1
Enviaia (0.8%)	1	1	1	1
CTT Express (0.8%)	1	1	1	1
Sending (0.6%)	1	1	1	1
Other (24.3%)	>40	>40	>40	>40

One relevant issue is the “Other” category, which groups nearly 25% of deliveries. This long tail (not quantified, since the breakdown was not available), represents a high number of LCVs carrying few parcels. In addition, this proportion of LCVs remained constant throughout the periods analyzed, since increasing the number of parcels also increased the number of delivery hours in the central district and load optimization of each LCV, but not the number of vehicles required.

5.5. Calculation of the Fleet of Delivery Vans

Considering LCVs emissions based on parcels delivered and kilometers driven in each daily route, the environmental impact derived from the delivery of e-commerce parcels during the periods analyzed, measured in kg of CO₂ equivalent, is shown in Figure 11. CO₂ emissions for Q1 of both years are very similar in line with the number of packages delivered. On the other hand, for Q2, the increase in e-commerce orders (+98%) translates into a higher number of emissions but, due to the higher delivery productivity during the COVID-19 period, the increase in CO₂ is lower (+43.1%).

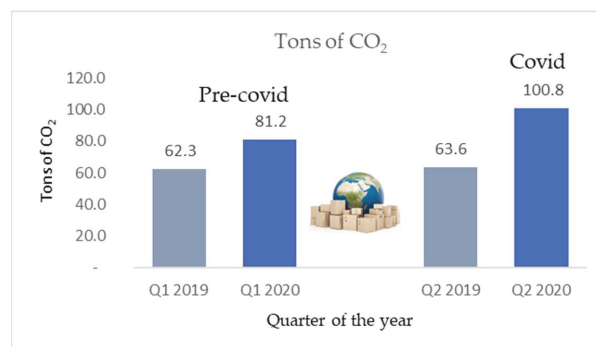

Figure 11. Tons of CO₂ emissions.

The reference value to calculate emissions is kgCO₂ per km, following the data from the DPGroup (2019) and Deloitte (2020).

6. Discussion

The analysis of results seeks to answer in greater detail the questions posed at the start of the study. Table 4 reflects the number of vehicles per hour and access volume to the Madrid Central area for three specific time periods: January–June 2019 (pre-Covid), from January 1 to March 13 (pre-Covid) and from 13 March to 30 June (during Covid).

Table 4. Central district traffic statistics.

Date	AADT (Vehicles/h)			Vehicle Access (Vehicles/Day)			Vehicle Access (LCVs/Day)		
	Mean	SD	% Mean	Mean	SD	% Mean	Mean	SD	% Mean
(Q1+Q2) 2019	444	62	-	131,351	21,371	-	12,764	5580	-
01/01–03/13/20	439	48	−1.05	125,375	15,596	−4.55	11,415	4827	−10.57
03/14–06/30/20	166	83	−62.24	41,095	24,227	−67.22	6079	3789	−46.74

In Madrid, COVID-19 paralyzed all activities considered as nonessential and, therefore, movement was limited to these basic activities. On average, traffic intensity decreased by 62.24%. In turn, since the Government implemented the State of Alarm which locked down most of the population until the so-called “new normal” (11/05/2020), road traffic dropped, on average, down to 76.28%. Similar results were reported in the UK, where road traffic volumes fell by as much as 73% (Budd and Ison 2020), and in other cities around the world: New York (−74%), Barcelona (−73%), Milan (−74%), Stockholm (−48%) and Sao Paulo (−55%) (year-on-year traffic reduction between 16 March to 22 March 2020; Statista 2020b). In this context, all modes of transportation were affected and it would be interesting to know how citizens changed their daily commute preferences due to the healthcare crisis. In the case of car access volume, the reduction was similar for total vehicles (67.22%), but significantly lower for LCVs (46.74%). This observation is explained by the fact that, due to the state of alarm, access to the central district was restricted to key activities, including supply of essential goods and services, home delivery of food, healthcare services and the necessary industry to conduct key activities. Under normal conditions, urban distribution accounts for 20% of total traffic in Madrid (DGT 2020), but this percentage rose during the analyzed period, due to the decrease in general traffic when compared to LCV traffic reduction. Focusing only on the period of the state of alarm, overall vehicle access to the Madrid Central area fell by 82.18% and in the specific case of LCVs, by 67.38%.

In contrast, e-commerce transactions saw a significant increase during that same period, as consumers embraced new ways of shopping and adopted new consumption habits due to the lockdown. Comparing the second quarter of 2020 (amidst the pandemic) with the same period from the previous year highlights a doubling of e-commerce retail purchases for residents of the Madrid Central area (see Figure 8). It is important to note that this growth of e-commerce was not only due to an increase in shopping frequency by customers who already used the online channel, but also the emergence of new buyers who had previously been reluctant to make purchases through the Internet (ONTSI 2020). The necessity created by the limitations imposed forced these new customers to face that unknown barrier. All the signs seem to indicate that, once this obstacle has been overcome, most new customers will continue making purchases through the new channel.

This increase in e-commerce orders translated into a larger number of LCVs circulating through the city but, as a result of the reduced traffic, the number of parcels delivered in each route increased and less LCVs were required to absorb the increase (higher load optimization per LCV). Given the large number of couriers with a small market share, one alternative to consider would be the consolidation of these operators’ e-commerce parcels through a microhub located in the central district. This could be implemented via public (microhub) and private (logistics operators) collaboration.

In order to better compare the main magnitudes of the study, Figure 12 shows the variations in the periods analyzed.

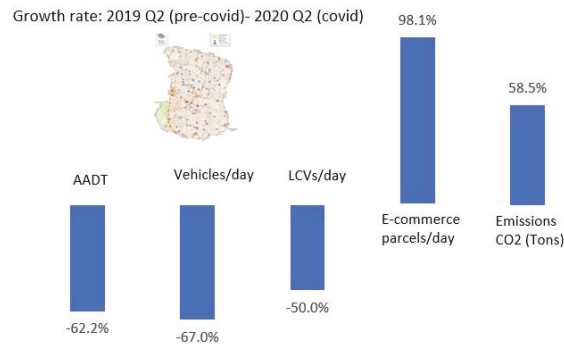

Figure 12. Variation in the analyzed magnitudes.

Lastly, from a sustainability standpoint, it is important to highlight the increase in CO₂ caused by the growth of e-commerce for residents of the Madrid Central area. Comparing the second quarter of both years, emissions rose by 50%, a smaller increase than that experienced by the number of parcels. A greater decrease in emissions should be sought through the use of other, cleaner means for last-mile deliveries (bicycles, delivery on foot, electric vehicles, etc.) or else through greater productivity in the LCV kilometer/delivered parcel ratio. The option of incorporating a microhub to consolidate parcels would also lead to a reduction in CO₂ emissions.

With regard to congestion, the increase in e-commerce parcels has meant an increase in vans in the central district, but in a significantly lower proportion than the increase of online orders. This is explained by three main reasons: (i) the reduction in traffic intensity increases the number of parcels delivered through each route, (ii) transport operators with a lower market share are able to load more parcels into each vehicle and (iii) the greater the demand for parcels in a given delivery area, the greater the possibility of delivering multiple orders in each stop.

7. Conclusions and Future Perspectives

This study describes the impact of COVID-19 on traffic in the urban center of a large city. In addition, it quantifies the demand for e-commerce parcels by residents of an urban center and estimates the impact on LCV traffic, considering its environmental repercussions. The results, applied to the central district of a city like Madrid, seek to answer the questions posed in the introduction.

First and foremost, road traffic in the Madrid Central area was directly affected by the lockdown measures. During the period of the pandemic analyzed (Q2 2019), economic activity entered a state of hibernation and mobility was reduced to essential activities, which reduced traffic to approximately 35% of normal rates.

The exception was e-commerce, where transactions for physical goods increased by 98% during this period, in line with online retail shopping behavior in other EU countries and the US (Eurostat 2021; BCG Global 2020). The growth of e-commerce caused an increase in the number of vehicles dedicated to transporting e-commerce orders, albeit in a notably smaller proportion than the increase in demand. Courier companies have found themselves in an ideal scenario with increased demand and empty streets, enabling them to make deliveries with very few limitations.

In this exceptional context, it would not be reasonable to apply public intervention measures, as these generally focus on decreasing traffic congestion and vehicle emissions under circumstances of traffic saturation, a situation which did not take place. CO₂ emissions related to e-commerce last-mile increased 43.1% during the pandemic period,

but this increase in CO₂ is no relevant if we consider the global reduction of all pollutant emissions in cities due the reduction in traffic and other activities. Average NO₂ levels during the week of 16–22 March went down by 41% in Madrid, 51% in Lisbon, 55% in Barcelona, 21% in Milan and 26–35% in Rome (Cheval et al. 2020). Therefore, environmental measures could focus on using innovative technologies: IoT (Internet of Things), big data, parcel lockers, electric vehicles, route optimization algorithms, collaboration among couriers and the use of urban distribution centers (Taniguchi et al. 2020).

Will the world after COVID-19 bring a new normality or a new reality? It is undeniable that, once the pandemic is over, the world will be substantially different in multiple aspects. Two such examples are those studied in this research: urban mobility and an increase in e-commerce. In this new, uncertain scenario, it will be essential to adopt measures that stakeholders can agree upon, in order to improve urban distribution in large cities from a sustainable perspective. Focusing on the environmental perspective, the increase in courier activities, added to the new consumption and mobility trends, highlight the need to promote improvements in the current models for urban transport and distribution of goods, including: public-private collaboration for retailers and for transport and logistics operators, environmentally friendly vehicles for city dwellers and raising e-commerce customer awareness and regulation (Russo and Comi 2020).

Inevitably, the study has several limitations, which provide valuable paths for future research. First, it would be relevant to have a complete picture of citizen mobility during the pandemic, that is, to know the exact percentage who used public transport, how many used their private vehicles and how many chose to move around on foot or by bicycle. This would provide an understanding of the transfers that took place between different modes of transportation. Obtaining this information for the post-Covid period could be very useful in defining better urban mobility and logistics policies in the future. Another essential element would be calculating the exact percentage of vehicles employed in urban logistics versus total traffic. Understanding this information and knowing delivery schedules would contribute to more efficient and sustainable proposals for urban logistics and traffic in big cities. Furthermore, it would be valuable to study how other modes of delivery (smart lockers, collection points, etc.) may contribute to improve economic aspects for couriers and social and environmental aspects for the city.

Lastly, this study could be extended from the perspective of city logistics operators, examining specific initiatives to improve urban distribution of goods in the context analyzed. Likewise, it would be useful to extend this study to evaluate the economic, social and environmental impact of the pandemic on both road traffic in general and urban distribution of goods in particular. Moreover, this analysis requires more detailed studies considering the new post-Covid reality, where mobility in the city will be different and new consumer habits will require more resilient and efficient urban logistics. These aspects will be developed in future research.

Author Contributions: All authors contributed equally to the data preparation and the analysis and to the interpretation of results. All authors made major contributions to writing the manuscript. All authors have read and agreed to the published version of the manuscript.

Funding: This research received no external funding.

Institutional Review Board Statement: Not applicable.

Informed Consent Statement: Not applicable.

Data Availability Statement: Data related to E-commerce transactions can be found in CNMC database at <http://data.cnmc.es/datagraph/>. Data related to traffic measurement can be found in Madrid city council data at <https://datos.madrid.es/portal/site/egob>. Data for the calculation of the variables in E-commerce parcels demand can be found in ONTSI at <https://www.ontsi.red.es/ontsi-data>.

Conflicts of Interest: The authors declare no conflict of interest.

Appendix A

- Productivity of LVCs in Madrid: 80–125 parcels/day
- Kms driven by LCVs in Madrid: 70–125 kms/day
- Emissions per van: 180–250 g CO₂/km

The values considered in the case of the Madrid Central area are as follows:

Operational Aspect	Traffic: Dense Loading/Unloading: Difficult (Pre-Covid Period)	Traffic: Fluid Loading/Unloading: Easy (Covid Period)
Productivity LVCs/day	80	125
Kms driven LVCs/day	72	90
Emissions per LCV	250 g CO ₂ /km	

Interval of 80–125 parcels/LCV considers traffic intensity (Deloitte 2020; International Post Corporation 2018; DPDgroup 2019).

References

- Allen, Julian, Stephen Anderson, Michael Browne, and Peter Jones. 2000. A framework for considering policies to encourage sustainable urban freight traffic and goods/service flows. In *Transport Studies Group*. London: University of Westminster.
- ANFAC. 2019. Annual Report 2018. Available online: <https://anfac.com/wp-content/uploads/2019/07/ANFAC-Annual-Report-2018.pdf> (accessed on 10 January 2021).
- Área de Gobierno de Medioambiente y Movilidad. 2019. Madrid 360: Avance de la Estrategia de Sostenibilidad Ambiental. Available online: <https://www.madrid.es/UnidadesDescentralizadas/UDCMedios/noticias/2019/09%20septiembre/30Lunes/Notasprensa/Presentaci%C3%B3n%20Madrid%20360/ficheros/Avance-Estrategia-Sostenibilidad-Ambiental-Madrid-360.pdf> (accessed on 25 January 2021).
- BCG Global. 2020. Can Delivery Companies Keep Up with the E-Commerce Boom? Available online: <https://www.bcg.com/publications/2020/can-delivery-companies-keep-up-with-the-ecommerce-boom> (accessed on 31 March 2021).
- Browne, Michael, Julian Allen, Toshinori Nemoto, Daniele Patier, and Johan Visser. 2012. Reducing Social and Environmental Impacts of Urban Freight Transport: A Review of Some Major Cities. *Procedia—Social and Behavioral Sciences* 39: 19–33. [CrossRef]
- Budd, Lucy, and Stephen Ison. 2020. Responsible Transport: A post-COVID agenda for transport policy and practice. *Transportation Research Interdisciplinary Perspectives* 6. [CrossRef]
- Cardenas, Ivan, Yari Borbon-Galvez, Thomas Verlinden, Eddy Van de Voorde, Thierry Vanelslender, and Wouter Dewulf. 2017. City Logistics, Urban Goods Distribution and Last Mile Delivery and Collection. *Competition and Regulation in Network Industries* 18: 22–43. [CrossRef]
- Cattaruzza, Diego, Nabil Absi, Dominique Feillet, and Jesús González-Feliu. 2017. Vehicle Routing Problems for City Logistics. *EURO Journal on Transportation and Logistics* 6: 51–79. [CrossRef]
- Cheval, Sorin, Cristian Mihai Adamescu, Teodoro Georgiadis, Mathew Herrnegger, Adrian Piticar, and y David R. Legates. 2020. Observed and Potential Impacts of the COVID-19 Pandemic on the Environment. *International Journal of Environmental Research and Public Health* 17: 4140. [CrossRef] [PubMed]
- CIVITAS. 2015. Smart Choices for Cities Making Urban Freight Logistics More Sustainable. Available online: https://civitas.eu/sites/default/files/civ_pol-an5_urban_web.pdf (accessed on 15 February 2021).
- CNMC. 2019. Informe Anual Sobre la Evolución del Sector Postal en 2019. Available online: https://www.cnmc.es/sites/default/files/3284892_13.pdf (accessed on 30 March 2021).
- CNMC. 2020. CNMC Household Panel, 2019. Available online: <http://data.cnmc.es/datagraph/> (accessed on 15 January 2021).
- Crainic, Teodor Gabriel, Nicoletta Ricciardi, and Giovanni Storch. 2004. Advanced Freight Transportation Systems for Congested Urban Areas. *Transportation Research Part C: Emerging Technologies* 12: 119–37. [CrossRef]
- Dablanc, Laetitia. 2011. City Distribution, a Key Element of the Urban Economy: Guidelines for Practitioners. In *City Distribution and Urban Freight Transport*. Cheltenham: Edward Elgar Publishing, pp. 20–44.
- Dablanc, Laetitia, Eleonora Morganti, Niklas Arvidsson, Johan Woxenius, Michael Browne, and Neila Saidi. 2017. The rise of on-demand “instant deliveries” in European cities. *Supply Chain Forum: An International Journal* 18: 203–17. [CrossRef]
- Delivery Hero: Quick Commerce: Pioneering the Next Generation of Delivery. 2020. Available online: <https://www.deliveryhero.com/blog/quick-commerce/> (accessed on 15 January 2021).
- Deloitte. 2020. Logística de Última Milla. Retos y Soluciones en España. Available online: <https://www2.deloitte.com/es/es/pages/operations/articles/logistica-de-ultima-milla.html> (accessed on 15 January 2021).
- Demir, Emrah, Yuan Huang, Sebastiaan Scholts, and Tom Van Woensel. 2015. A Selected Review on the Negative Externalities of the Freight Transportation: Modeling and Pricing. *Transportation Research Part E: Logistics and Transportation Review* 77: 95–114. [CrossRef]

- DGT. 2020. Evolución de Tráfico Por el Efecto de COVID-19. Available online: https://www.dgt.es/es/COVID-19/index_20200330/ (accessed on 31 March 2021).
- DPDgroup. 2019. Driving Change. Corporate Social Responsibility. Available online: https://www.dpd.com/group/wp-content/uploads/sites/77/2019/06/20190619_DPDgroup_CSR-report-2018_EN.pdf (accessed on 18 January 2021).
- E-Commerce Europe. 2021. Impact of the Coronavirus on E-Commerce. Available online: <https://ecommerce-europe.eu/wp-content/uploads/2021/01/Coronavirus-Survey-Report-January-2021.pdf> (accessed on 23 March 2021).
- European Commission. 2020. Sustainable and Smart Mobility Strategy—Putting European Transport on Track for the Future. Available online: https://eur-lex.europa.eu/resource.html?uri=cellar:5e601657-3b06-11eb-b27b-01aa75ed71a1.0001.02/DOC_1&format=PDF (accessed on 20 January 2021).
- European Commission. 2021. Mobility and Transport: Clean transport, Urban Transport. Available online: https://ec.europa.eu/transport/themes/urban/urban_mobility_en (accessed on 20 January 2021).
- Eurostat. 2021. Online Shopping Ever More Popular in 2020. Available online: <https://ec.europa.eu/eurostat/web/products-eurostat-news/-/ddn-20210217-1> (accessed on 31 March 2021).
- Gatta, Valerio, and Edoardo Marcucci. 2014. Urban Freight Transport and Policy Changes: Improving Decision Makers' Awareness via an Agent-Specific Approach. *Transport Policy* 36: 248–52. [CrossRef]
- González-Feliu, Jesus, Christian Ambrosini, and Jean-Louis Routhier. 2012. New Trends on Urban Goods Movement: Modelling and Simulation of E-Commerce Distribution. Post-Print. HAL. Available online: <https://econpapers.repec.org/paper/haljournal/halshs-00626152.htm> (accessed on 15 January 2021).
- INE. 2020a. Población del Padrón Continuo por Unidad Poblacional a 1 de enero. Available online: <https://www.ine.es/nomen2/index.do?accion=busquedaDesdeHome&nombrePoblacion=Madrid> (accessed on 15 January 2021).
- INE. 2020b. Renta Por Persona y Unidad Consumo Por Comunidades Autónomas. Available online: <https://www.ine.es/jaxiT3/Tabla.htm?t=9947> (accessed on 15 January 2021).
- INRIX. 2020. Global Traffic Scorecard. INRIX Research, March 2020. Available online: <https://inrix.com/scorecard/> (accessed on 15 January 2021).
- International Conference on City Logistics, Eiichi Taniguchi, and Russell G. Thompson, eds. 2004. *Logistics Systems for Sustainable Cities*. Amsterdam: Elsevier.
- International Post Corporation. 2018. Postal Sector Sustainability Report 2018. Available online: <https://www.ipc.be/sector-data/reports-library/ipc-reports-brochures/sr2018> (accessed on 25 March 2021).
- Ivanov, Dmitry. 2020. Predicting the Impacts of Epidemic Outbreaks on Global Supply Chains: A Simulation-Based Analysis on the Coronavirus Outbreak (COVID-19/SARS-CoV-2) Case. *Transportation Research Part E: Logistics and Transportation Review* 136. [CrossRef] [PubMed]
- Khomenko, Sasha, Marta Cirach, Evelise Pereira-Barboza, Natalie Mueller, Jose Barrera-Gómez, David Rojas-Rueda, Kees de Hoogh, Gerard Hoek, and Mark Nieuwenhuijsen. 2021. Premature Mortality Due to Air Pollution in European Cities: A Health Impact Assessment. *The Lancet Planetary Health* 5: e121–e134. [CrossRef]
- Koch, Julia, Britta Frommeyer, and Gerhard Schewe. 2020. Online Shopping Motives during the COVID-19 Pandemic—Lessons from the Crisis. *Sustainability* 12: 10247. [CrossRef]
- Kotler, Philip, and Kevin Keller. 2012. *Dirección de Marketing. Place of Publication Not Identified*. London: Pearson Education.
- Lebeau, Philippe, and Cathy Macharis. 2014. Freight transport in Brussels and its impact on road traffic? *Brussels Studies*. [CrossRef]
- Linton, Tom, and Bindiya Vakil. 2020. Coronavirus Is Proving We Need More Resilient Supply Chains. *Harvard Business Review*. Available online: <https://hbr.org/2020/03/coronavirus-is-proving-that-we-need-more-resilient-supply-chains> (accessed on 1 April 2021).
- Macharis, Cathy, and Bram Kin. 2017. The 4 A's of Sustainable City Distribution: Innovative Solutions and Challenges Ahead. *International Journal of Sustainable Transportation* 11: 59–71. [CrossRef]
- Macharis, Cathy, and Sandra Melo, eds. 2011. City distribution and urban freight transport: multiple perspectives. In *NECTAR Series on Transportation and Communications Networks Research*. Cheltenham and Northampton: Edward Elgar.
- Madrid City Council Environment and Mobility Office. 2019. Portal web del Ayuntamiento de Madrid. Inventario de Emisiones. Available online: [https://www.madrid.es/portales/munimadrid/es/Inicio/El-Ayuntamiento/Medio-ambiente/Cambio-Climatico/?vgnnextfmt=default&vgnnextoid=0ca36936042fc310VgnVCM1000000b205a0aRCRD&vgnnextchannel=4b3a171c30036010VgnVCM100000dc0ca8c0RCRD&idCapitulo=6877178](https://www.madrid.es/portales/munimadrid/es/Inicio/El-Ayuntamiento/Medio-ambiente/Cambio-Climatico/?vgnnextfmt=default&vgnextoid=0ca36936042fc310VgnVCM1000000b205a0aRCRD&vgnnextchannel=4b3a171c30036010VgnVCM100000dc0ca8c0RCRD&idCapitulo=6877178) (accessed on 20 January 2021).
- Madrid College of Economists. 2020. *Hacia una Nueva Movilidad en las Ciudades*. Junio de 2020/N°169. Madrid: Madrid College of Economists.
- Muñuzuri, Jesús, Juan Larrañeta, Luis Onieva, and Pablo Cortés. 2005. Solutions Applicable by Local Administrations for Urban Logistics Improvement. *Cities* 22: 15–28. [CrossRef]
- OECD. 2020a. E-Commerce in the Time of COVID-19. Available online: <http://www.oecd.org/coronavirus/policy-responses/e-commerce-in-the-time-of-covid-19-3a2b78e8/#endnotea0z3> (accessed on 31 March 2021).
- OECD. 2020b. Connecting Businesses and Consumers during COVID-19: Trade in Parcels. OECD Policy Responses to Coronavirus (COVID-19). Available online: <http://www.oecd.org/coronavirus/policy-responses/connecting-businesses-and-consumers-during-covid-19-trade-in-parcels-d18de131/> (accessed on 23 March 2021).

- ONTSI. 2020. El Comercio Electrónico B2C en España 2019 (Edición 2020). Available online: <https://www.ontsi.red.es/es/estudios-e-informes/Hogares-y-ciudadanos/El-Comercio-Electronico-B2C-en-Espana-2019-%28Edicion-2020%29> (accessed on 15 January 2021).
- Ranieri, Luigi, Salvatore Digiesi, Bartolomeo Silvestri, and Michele Roccotelli. 2018. A Review of Last Mile Logistics Innovations in an Externalities Cost Reduction Vision. *Sustainability* 10: 782. [CrossRef]
- Russo, Francesco, and Antonio Comi. 2011. A Model System for the Ex-Ante Assessment of City Logistics Measures. *Research in Transportation Economics* 31: 81–87. [CrossRef]
- Russo, Francesco, and Antonio Comi. 2020. Investigating the Effects of City Logistics Measures on the Economy of the City. *Sustainability* 12: 1439. [CrossRef]
- Savelsbergh, Martin, and Tom Van Woensel. 2016. City Logistics: Challenges and Opportunities. *Transportation Science* 50: 579–90. [CrossRef]
- Srinivas, S. Srivatsa, and Rahul R. Marathe. 2021. Moving towards “Mobile Warehouse”: Last-Mile Logistics during COVID-19 and Beyond. *Transportation Research Interdisciplinary Perspectives* 10. [CrossRef]
- Stathopoulos, Amanda, Eva Valeri, and Edoardo Marcucci. 2012. Stakeholder Reactions to Urban Freight Policy Innovation. *Journal of Transport Geography*, 34–45. [CrossRef]
- Statista. 2020a. COVID-19 Impact on Global Retail E-Commerce Site Traffic 2019–2020. Available online: <https://www.statista.com/statistics/1112595/COVID-19-impact-retail-e-commerce-site-traffic-global/> (accessed on 20 January 2021).
- Statista. 2020b. COVID-19: Traffic Reduction in Selected Cities Worldwide. Available online: <https://www.statista.com/statistics/1106135/change-in-daily-traffic-volume-amid-coronavirus-crisis-key-countries/> (accessed on 1 April 2021).
- Taniguchi, Eiichi, Russell G. Thompson, and y Ali G. Qureshi. 2020. Modelling City Logistics Using Recent Innovative Technologies. *Transportation Research Procedia*, 3–12. [CrossRef]
- Viu-Roig, Marta, and Eduard Alvarez-Palau. 2020. The Impact of E-Commerce-Related Last-Mile Logistics on Cities: A Systematic Literature Review. *Sustainability* 12: 6492. [CrossRef]
- We Are Social and Hootsuite. 2021. Digital 2020. Global Digital Overview. Available online: <https://wearesocial.com/digital-2020> (accessed on 15 January 2021).

Article

Developing Corporate Sustainability Assessment Methods for Oil and Gas Companies

Tatyana Ponomarenko, Oksana Marinina *, Marina Nevskaya and Kristina Kuryakova

Faculty of Economics, Saint Petersburg Mining University, 199106 Saint Petersburg, Russia; stv@spmi.ru (T.P.); nevszkaya_ma04@spmi.ru (M.N.); kristinkuryakova@gmail.com (K.K.)

* Correspondence: moa95@yandex.ru

Abstract: As it is predicted that there will be a decrease in production at the oil and gas facilities that are currently operating, it becomes necessary to start developing new oil and gas fields. This results in changes to the state's policy regarding the participation of private companies in the development and implementation of oil and gas offshore exploration and production new projects. Access to unique fields can be provided to the most socially responsible companies. The purpose of this study is to present the author's methodology for assessing the dynamics of corporate sustainability. The methodology is based on the assessment of individual, well-founded indicators of sustainable development of companies. The proposed methodology takes into account factors in areas such as occupational health and safety, environmental protection and economic efficiency and identifies two performance indicators. The first indicator is an aggregated index for three groups of factors to assess company ratings relative to the performance of the best company. The second indicator is an assessment of the dynamics within the company relative to the previous values of indicators of corporate social responsibility. The research results obtained using the proposed methodology show that oil and gas companies differ significantly in terms of corporate sustainability. The developed methodology for assessing corporate sustainability is of practical importance and can be used by companies in the analysis and planning of operating and investment activities that ensure the achievement of goals of corporate social responsibility.

Keywords: corporate sustainability; corporate social responsibility; economic results; environmental responsibility; social welfare; oil and gas fields

Citation: Ponomarenko, Tatyana, Oksana Marinina, Marina Nevskaya, and Kristina Kuryakova. 2021. Developing Corporate Sustainability Assessment Methods for Oil and Gas Companies. *Economics* 9: 58. <https://doi.org/10.3390/economics9020058>

Academic Editor: Angeliki N. Menegaki

Received: 8 March 2021

Accepted: 6 April 2021

Published: 14 April 2021

Publisher's Note: MDPI stays neutral with regard to jurisdictional claims in published maps and institutional affiliations.



Copyright: © 2021 by the authors. Licensee MDPI, Basel, Switzerland. This article is an open access article distributed under the terms and conditions of the Creative Commons Attribution (CC BY) license (<https://creativecommons.org/licenses/by/4.0/>).

1. Introduction

At present, corporate social responsibility (CSR), a sustainable development (SD) assessment, is a rather difficult procedure for a number of reasons. Theoretical and methodological approaches to measuring corporate indicators for assessing sustainability (CS) and CSR are being actively developed, but this is happening in a somewhat haphazard way. There are several reasons for this. First, SD is predominately studied at the global and national levels, with CS concepts being hardly developed. Second, the relationship between CS and CSR has not been studied thoroughly enough. Third, there is a variety of CS assessment indicators, which is a result of various concepts underlying research methodologies and the fact that there is no single definition of CS. It follows that the methodology for assessing SD effectiveness requires further research and development (Ponomarenko et al. 2020; Szwerański and Kazak 2020).

Corporate sustainability assessment methods differ in the number and composition of indicators, the degree of aggregation, the method of calculating the resulting value, weighting factors and assessing the degree of the company's progress in corporate sustainability. Official methods are universal and can be applied to all companies regardless of their specifics. However, some researchers have proposed methods that take into account the specifics of the industry but they are hardly used in practice and have not been officially recognized. The peculiarity of corporate sustainability assessment methods lies in the

fact that the algorithm is usually unknown for selecting the criteria, weighting factors and calculation rules and the reliability of the procedure should be verified by disclosing information on the approach to collecting and verifying information relevant for research.

The purpose of this study is to develop a methodology for assessing corporate sustainability and changes in the field of sustainable development and benchmark oil and gas companies using social and environmental indicators in order to reveal potential participants in the joint development of oil and gas fields.

The article provides an analysis and systematization of corporate sustainability assessment methods aimed at identifying the limitations and possibilities of using the methodology for assessing the level of CSR in oil and gas companies. A new methodology is proposed for assessing corporate sustainability in order to analyze the level of and changes in corporate sustainability taking into account target indicators. The results are given and conclusions are made on testing the methodology using a case study of oil and gas companies. The article discusses the limitations of the methodology for assessing the level of CSR and reflects on how it can be developed in the future.

The structure of the article includes:

Section 1 (“Corporate sustainability: definition and assessment methods”), which discusses some interpretations of corporate sustainability in comparison with corporate social responsibility and sustainable development, as well as characteristics of the most popular methods for assessing corporate sustainability.

Section 2 (“Materials and Methods”), which presents the details of the methodology that was developed by the authors, including the set of methods for assessing, the selection of indicators and the development of integral indicators for assessing corporate sustainability. The technique, which was chosen as the main one for the further development of the author’s technique, is analyzed. The choice of mining companies as a base for testing the method is substantiated.

Section 3 (“Results”), which contains the details of the methodology that was developed by the authors, including the selection of indicators and the development of integral indicators for assessing corporate sustainability at present and over time; analytical and graphical results of assessing corporate sustainability in six Russian oil and gas companies.

Section 4 (“Discussion”) includes a study of the place that the proposed methodology takes in the classification of methods for assessing corporate sustainability based on various criteria and identifies the limitations of the methodology.

Section 5 (“Conclusion”) contains the key findings of the study.

1.1. Definitions of Corporate Sustainability, Corporate Social Responsibility and Sustainable Development

Despite a geometric growth of works on this issue, there has not been a common definition of CS for 30 years of the concept development. Many researchers confuse the concepts of corporate social responsibility (CSR) and corporate sustainability (CS), while others replace corporate sustainability by environmental sustainability; thus, corporate sustainability is the most uncertain among the related categories. It results from the logical course of the concept development: from environmental and social sustainability to CS based on a threefold approach. The weakest theoretical points of CS are non-formalized relations between various CS spheres and an unaccounted-for long-term nature of CS. In the existing systems of indicators, the proportion of each sphere has no rational backing and a long-term nature of CS is practically not counted. Apart from that, the fact that oil and gas companies use public-owned valuable mineral resources and have a special environmental impact (soil, air, water, biodiversity) complicates creation of a valid system of indicators.

Theoretical and methodological approaches to measuring corporate indicators used in CS assessment are being actively developed but they do not form a system. This is due to a number of circumstances. First, in various studies on the issue, the relationship between CS and CSR has not been analyzed thoroughly enough. Second, there is a variety of CS

assessment indicators, which results from the fact that there is no universally accepted definition of CS and the concept itself is analyzed from different points of view.

Over the past three decades, a lot of attention has been paid by academic circles to different CS aspects.

Development of the stakeholder approach, according to the theory of E. Freeman (Freeman 1984), is based on an expanding interest range of stakeholders and their obligations to the society (Smol et al. 2020; Tulaeva et al. 2019; Novikova 2020).

An institutional approach to CSR, development of the concepts of corporate citizenship, corporate susceptibility and corporate activity as a result of expanding spheres of influence and functions of large businesses (Montiel and Delgado-Ceballos 2014; Freeman 1984).

From 1987 (Brundtland reports) until the middle of 1990 the research of CS was aimed at identifying and formulating signs of CS; later (until mid-2000) strategic management research was focused on finding tools and strategies of CS and maximizing the level of CS. Then, the concept of CS became comprehensive and combined all three spheres. The theoretical background of CS includes: a stakeholder and institutional theory, a resource-oriented concept, a new theory of “sustaincentrism”. A stakeholder theory explains CS drivers by satisfied respective interests of stakeholders; an institutional theory explains evolution and diffusion of institutions into various areas of CS; a resource approach identifies what resources a company needs for an effective CS strategy; while the new CS theory formulates a detailed definition of CS and focuses on a shift from anthropocentric to a “sustainable centric” approach (Drucker 1984; Berman et al. 1999; Margolis and Walsh 2003; Johnson 2003; Halme and Laurila 2009; Blagov 2011; Nedosekin et al. 2019).

In this article, we treat corporate sustainability as a successful establishment of a company in three traditional spheres of sustainable development (economic, social and environmental), taking into account long-term relations of these spheres and a comprehensive concept of CS. When determining CS of a mining company, we should take into account whether the corporate economic quantitative and qualitative profile complies with environmental and social requirements, how the company responds to relevant challenges in the long term. Thus, the idea of socially responsible business is becoming mandatory in modern conditions.

A review of literature on the issue of sustainable development at the micro level (corporate sustainability) shows that there has been a significant interest in this issue for decades, which led to the emergence and development of various ideas and views. At the same time, the variety of studies in this area stems from the fact that there is no universally accepted definition of the basic concept of sustainable development at the micro level (i.e., corporate sustainability), with this term being used along with similar ones, such as corporate social responsibility, sustainable development and others.

By systemizing the approaches to defining the concept of corporate sustainability presented in current foreign literature on the topic (Endovickij et al. 2017), the following types were identified:

(1) corporate sustainability in relation to and in connection with corporate social responsibility (CSR):

- corporate sustainability in the sense that is synonymous with CSR;
- corporate sustainability in the sense that is not synonymous with CSR;
- CSR as a factor ensuring corporate sustainability;

(2) a monofocal definition of corporate sustainability:

- corporate sustainability is the observance of moral standards;
- corporate sustainability is a strategy implemented by executives;

(3) umbrella approaches to defining corporate sustainability:

- corporate sustainability is determined by many indicators and characteristics of a company (economic growth, product quality, business reputation, organizational structure, stakeholder relationships, environmental protection and others) simultaneously;
- the triune concept of corporate sustainability (based on TBL);

- corporate sustainability as a driver of economic results;
- corporate sustainability as a consequence of achieving particular results that are measured using instruments developed by organizations (for example, the Dow Jones Sustainability Index, the Shanghai Stock Exchange Sustainable Development Industry Index).

A closer look at these interpretations shows that there is some confusion between corporate sustainability and CSR, but attempts are made to identify the specific features of corporate sustainability; the emphasis is placed on the activity (both strategic and operational) aimed at achieving sustainability, its long-term nature and the creation of different values at the company level. The most important task is to identify the range of issues discussed within the framework of corporate sustainability, relationships between them and their significance. Two approaches can be distinguished here.

Proponents of the first approach understand by corporate sustainability the company's economic sustainability which manifests itself in its long-term economic performance (Epstein and Roy 2003), sustaining its competitive advantages, profitability, a high market capitalization, highly priced stocks and successful risk management. This approach generally corresponds with strategic management but even though it is long-term oriented, its focus is on economic performance. It is known that today's strategic and operational management takes into account the combination of goals and tools for achieving them in the economic, environmental and social spheres (Klimova et al. 2018). In the approach discussed above, environmental and social factors become boundaries and they are not equal to economic factors in terms of their importance. At the same time, quantitative research proves that there is a relationship between companies' performance indicators and the implementation of corporate sustainability practices (see, for example, (Ivashkovskaya 2009) I.V. Ivashkovskaya puts emphasis on the influence of environmental and social factors on the value of a company).

In the second approach, corporate sustainability is understood as a holistic view of the company in the context of achieving economic, environmental and social goals. This raises the issue of developing a balanced assessment system covering different types of the company's activities, including those in the economic, social and environmental spheres, giving an overall assessment and solving all management problems in the context of corporate sustainability at both the strategic and operational levels.

Analysis of scientific publications and official materials (GOST R ISO 9004 2010; GOST R ISO 20121 2014; GOST R 54598.1 2015) of organizations engaged in methodological guidance of SD showed that all methods differ in the number and set of assessment indicators, degree of their aggregation, methods for value calculation, proportion of indicators and assessment of corporate progress degree in CS. Official methods have a universal nature and can be applied to all companies without regard to their type of business. At the same time, methods of individual researchers have little practical application and are not officially recognized, although many of them are industry-specific and, therefore, show a certain progress in the scientific understanding of CS. What is distinct about CS assessing methods is that the algorithm for selecting the criteria, proportions of indicators and rules of calculations is unknown, so consistency and reliability of assessing procedures must be confirmed by explaining the approach to collection of reasonable information and a verification system.

Analysis of CSR and CS assessment methods showed that according to the target orientation and selection of key indicators or the main indicator (index), they can be divided into the following groups: (1) methods focused on collection of environmental information; (2) methods focused on assessment of social welfare, calculation of social indicators and indicators of social efficiency; (3) methods based on a comprehensive assessment of CSR; (4) methods of assessing corporate sustainability with a comprehensive assessment of corporate activities in environmental, social and economic areas (Table 1).

Table 1. The development of CSR concepts. Source: compiled by the authors. (Ponomarenko et al. 2020; Szebrański and Kazak 2020; Smol et al. 2020; Tulaeva et al. 2019; Novikova 2020; Montiel and Delgado-Ceballos 2014; Freeman 1984; Drucker 1984; Berman et al. 1999; Margolis and Walsh 2003; Johnson 2003; Halme and Laurila 2009; Blagov 2011; Nedosekin et al. 2019; Endovickij et al. 2017; Epstein and Roy 2003; Klimova et al. 2018; Ivashkovskaya 2009).

Attributes	Stakeholder Theory	Corporate Social Performance	Corporate Citizenship
Object	The relationships between the company and its key stakeholders	The company's activities in relation to its stakeholders	The relationship between the company and society
Essence	Identifying and taking into account the interests of parties involved, i.e., those who can influence the company's activities or be influenced by the side effects of the company's main activities	The company's ability to understand its impact on society and respond to the needs of stakeholders in the economic, social and environmental spheres	An integrated approach that includes not only legal rights and obligations but also additional responsibilities that lie beyond the company's boundaries and exist in the economic, social and environmental dimensions
Principles	The corporation is involved in resource mobilization in order to create well-being for its stakeholders and competitive advantages for itself	The underlying links between the principles of corporate social responsibility, corporate social performance and corporate strategy: 1. risk minimization, 2. profit maximization, 3. accountability to and responsibility for stakeholders	Companies take the position of a social institution and, having become a "good corporate citizen", share a number of social functions with the government. They contribute to sustainable development at the regional or even global level.
Implementation methods	It is not required to meet the social interests of all the company's stakeholders. The management should not pay too much attention to minor stakeholders who cannot influence the company's sustainability in the mid-term	Three strategies of stakeholder communication: information strategy, response strategy and involvement strategy	Identification of socially anchored competences, elimination of contradictions between the interests of the company and society in terms of social, environmental, ethical and economic aspects
Principal authors	Freeman R.E., S. Ramakrishna Velamuri, Brian Moriarty, Preston L., Post J.	Sethi S. P., Wood D.J., Carroll A. B.	Logsdon J.M., Wood D.J., Carroll A. B., Matten D., Crane A., Chapple W.

The methodology proposed by the authors for assessing corporate sustainability in mining companies was developed taking into account the essence, principles and methods of stakeholder theory, corporate social performance and corporate citizenship. The principles of stakeholder theory that was used includes resource mobilization, creating competitive advantages and creating stakeholders' well-being. According to the principles of corporate social performance, three aspects of interaction are assessed—economic, environmental and social—along with "inputs" (resource consumption) and "outputs" (impact). The concept of corporate citizenship takes into account the link between the regional and national levels of sustainable development, which was reflected in the choice of indicators that can be aggregated starting from the corporate level.

1.2. Methods Focused on Collection of Environmental Information and Calculation of Environmental Indicators

Such methods exist due to the fact that for several decades the environmental approach to SD assessment had dominated, with its close relations to the stakeholder theory, popular and clear definition of many environmental indicators. However, such methods are only aimed at the environmental side of activities of the companies (Larsena et al. 2018). An example of this is Carbon Disclosure Project (CDP) (CDP 2015), an independent non-profit organization that maintains the world's largest climate change database. CDP is the author of disclosure guidelines, as well as several environmental ratings (Carbon Disclosure Leaders Index—CDLI and Carbon Performance Leaders Index—CPLI). The

world's largest companies measure and publish climate change and gas emission data using a CDP survey-based method in order to set emission-reducing goals as part of their CS strategies. International principles for assessing social consequences and results (IAIA, International Association for Impact Assessment).

Of course, the issue of greenhouse gas emissions is one of the key environmental problems, it is very grave for companies in the mineral, oil and gas industry and allows us to assess the company's contribution to reduction of hydrocarbon emissions at a global level; however, this method does not allow consideration of the SD of companies in social and economic aspects.

1.3. Methods Focused on Assessment of Social Welfare, Calculation of Social Indicators and Indicators of Social Efficiency

Such methods are focused solely on social results that can be assessed by such parameters as demography, health and income, poverty level, educational level, migration, etc. "A high aggregation of social parameters makes them universal and allows adapting them to a particular country, collecting and summarizing a large array of statistical information" (Kanaeva 2018). One of the challenges for using such methods is a constant complication of social indicators (index). For example, introduction of such indicators as "degree of vulnerability", "social insecurity", "level of material and social inequality" and "level of public resilience to weather and climate anomalies" require a new justification of criteria, methods for their calculation and possible modification. Apart from that, existing systems of social indicators used at the global level sometimes cannot objectively assess social results at national levels, since they do not take into account geographical and climatic features of the countries and related national, traditional and cultural characteristics of natural resources consumption, need for social benefits, etc.

Methods focused on assessment of public welfare, calculation of social indicators and indicators of social efficiency include (Prokopov and Feoktistova 2008):

1. Social Impact Assessment (SIA), which is a method for considering social impacts and a way to assess the impact of certain projects on society (roads, industrial facilities, mines, dams, ports, airports and others);
2. Among methods for assessing social effectiveness, based mainly on a qualitative data analysis, it is worth noting SRA (Social Return Assessment);
3. The LBG model allows assessing the value and achievements of corporate investment into the community, as well as properly report to stakeholders. This model presents a matrix, which can be used to summarize and obtain quantitative information on the results of work with local communities. Dividing corporate activity into elements, the matrix offers a detailed study of various types of resource inputs, determines immediate or intermediate results/products (outputs) and, ultimately, presents the nature and degree of environment impacts (LBG Model 2017).

1.4. Methods Based on a Comprehensive Assessment of CSR

1. The SROI (Social Return on Investment) is based on the SCBA method and allows calculation of social efficiency of investments (social return on investment) (Emerson et al. 2000; Lingane and Olsen 2004). Social results are determined given the interests of stakeholders and are assessed by using subjective and objective indicators that most fully reflect the results obtained (A Guide 2012). This method does not use any sustainable indicators or results selected for specific conditions, company or project. However, this approach is focused on projects and does not allow assessing effectiveness of CSR of an operating company.
2. The SCBA (Social Costs-Benefit Analysis) is a tool of the welfare economy and it assesses social costs-benefits. As a rule, it is used to justify a state support of large socially significant projects (Wells 1975). It is supposed to make monetary assessment of private and external social costs (including environmental ones) (Manning et al. 2016).

The disadvantage of this method in assessing CSR is that it cannot take into account qualitative results to the full extent.

3. The DEA (Data Envelopment Analysis) is used to evaluate CSR activities in order to determine effectiveness of management decisions based on profitability criterion. This method presents only final ratings.
4. Since 1991 the KLD (Dowling Grahame 2013) index has been one of the most widely-used company analysis indices in seven areas: product quality and safety, relations with employees, corporate management, relations with the local community, human rights, environment, diversity, thus covering all main directions of SD. The method links social and financial indicators and demonstrates only final ratings.
5. Econometric Impact Index, offered by Smith O'Brien, allows assessing the total impact of the company on the local community. This index can be used both by the companies and local authorities involved in assessing the impact of those companies on the local community, including expanding or reducing production, pricing policy, tax payments and the impact on decision-making in regional development.

1.5. Methods for Assessing Corporate Sustainability with a Comprehensive Assessment of Corporate Activities in Environmental, Social and Economic Areas

The fourth group combines in-company methods of assessing corporate sustainability and comprehensive assessment of corporate activities in all areas of SD: environmental, social and economic. Assessment of CS indicators means assessment of economic results, impact on society (CSR) and impact on the environment.

The most common rating methods are as follows:

1. The ISS-oekom corporate rating (ISS-oekom Universe) includes assessment of more than 3900 companies; Oekom Corporate Ratings assess companies by using 100 social, managerial and environmental criteria (ISS-oekom 2019) weighted, aggregated and presented as a score, which makes up the background of rating of the companies;
2. ESG ratings are based on assessing the optimal set of special indicators reflecting the level of the company's impact on the natural and social environment, as well as the degree of corporate exposure to social and managerial risks (ESG Rating 2020);
3. DJSI Index (The Dow Jones Sustainability Index) is a set of indicators for assessing sustainability of large public companies—stock market players, selected under the corporate sustainability assessment made by RobecoSAM agency. DJSI indices are global benchmarks based on a set of criteria for assessing environmental, social and economic capacities of companies (JSI/CSA 2020), including weighting factors. The content and number of indicators within each criterion, as well as their weight factors can be adjusted in accordance with the recommendations of RobecoSAM;
4. The RobecoSAM agency methods are used not only to evaluate DJSI, but also to assess sustainable development of companies given their industrial profile. In this case, assessment uses specific industry criteria. For example, for mineral companies, economic criterion included payment transparency, environmental one—mineral waste mgmt., water related risks, biodiversity, social one—asset closure mgmt, community impact, stakeholder engagement (Corporate 2018).

Despite high popularity of SAM and DJSI methods, they have a drawback: information can be distorted as a result of self-assessment of companies (RepRisk Provides ESG 2014; Rahdari and Rostamy 2015);

5. Fortune ranking is based on comparison with the “top companies” and presents the final ranking data. It limits the ability of companies to self-evaluate and analyze internal effects, relies on fixed indicators not ranked by their significance, that is, it does not count for effectiveness as a reason of certain social investments;
6. The 2008 World Business Council for Sustainable Development (WBCSD) Guidelines together with the International Finance Corporation (IFC) define universal framework principles for identifying, measuring, assessing and prioritizing social effects, as well as indicators by value chain elements (WBCSD 2017).

Among national methods, the following are worth noting:

- (a) method for assessing basic performance indicators (BPI), developed by the Russian Union of Industrialists and Entrepreneurs (RUIE) under the Global Reporting Initiative (GRI) and intended for preparing corporate non-financial reports (social, sustainable development, environmental ones) and for corporate management systems in order to organize monitoring, control and assessment of key performance results. Basic performance indicators include 48 indicators in economic, social and environmental areas of the company (Global 2014);
- (b) The Social Reporting of Enterprises and Organizations Registered in the Russian Federation. Guidelines Standard prepared by the Chamber of Industry and Commerce under AA 1000 and GRI principles (Prokopov and Feoktistova 2008).

2. Methodology

The purpose of the study was to develop a method for assessment of corporate sustainability (CS) based on accumulated assessment tools.

For this purpose, more than 100 CSR and CS methods were analysed (Table 2). For analysis purposes the following methodologies were selected:

- International methods for assessing CS and social performance
- Methods for assessing CS and social performance with the industry specifics
- Methods and approaches for assessing social performance
- Russian rating methods for assessing CS and social performance
- Individual researchers' methods of assessing companies' performance.

The methodology of express assessment of CSR methodology Barzakova D.I. was chosen as the basis for the development of the methodology for assessing corporate governance. In the method of Barzakov D.I., the author proposes assessment indicators harmonized with the provisions of the global standard Global Reporting Initiative G4 (GRI G4) and combined into three groups: interaction with personnel, interaction with the local community and environmental protection. The final indicator is determined based on the point assessment of the dynamics of growth/decline of the GRI G4 indicators. The methodology allows for diagnostics and comparative analysis of companies in the field of CSR.

In our methodology, in addition to indicators from the Global Reporting Initiative G4 standard, economic indicators from the company's profit and loss statement have been added to focus more on the company's sustainability and not just corporate social responsibility. The proposed methodology takes into account three groups of indicators in the areas: labor protection, environmental protection and economic efficiency. Three indicators were selected in each group to create a balanced system of indicators.

Thorough consideration was given to the specific features of oil and gas companies.

Among the social indicators, three indicators were chosen that reflect social impact and the impact of the company on its employees (data on occupational injuries, Deloitte surveys), the local community (company reports) and the population at the regional and national levels, as they all form a single ecosystem. All the indicators correspond with the stakeholder approach.

Among the environmental indicators, three indicators were chosen that characterize the consumption of key natural resources and the impact on the environment) (Cherepovitsyn et al. 2018; Lipina et al. 2018; Ilinova et al. 2020), including energy consumption (as well as CO₂ emissions), water consumption (which is high in oil and gas companies) and waste (Vasilev et al. 2019; Ivanova 2020; Kirsanova et al. 2020). In the economic area, such indicators were chosen as cost-to-revenue ratio as a key indicator of economic performance, revenue as an indicator of the cumulative effect and oil and gas reserve life as a key factor connected with resources (Carayannis et al. 2021; Litvinenko et al. 2020; Rudakov et al. 2021).

Table 2. Classification of CS methods, ratings, indices. Source: (Wong et al. 2019; ESG 2019; ESG Factors in Investment, MIRBIS 2019; Rate the Raters 2020; Corporate 2018; RepRisk Provides ESG 2014; International Integrated Reporting Council ‘IIRC’ 2021; Leadership GRI SRS 2013; Global 2014; LBG Model 2017; Borzakov 2016; Sklyar and Zverkovich 2007; Pence and Furs 2008; Saprykina 2012; Endovitsky et al. 2014; Ponomarenko et al. 2020) compiled by the authors.

Kinds of Methodologies	Methods
Russian methodologies (ratings) for assessing CS and social performance	Basic indicators of RSPP (Methodology of the Russian Union of Industrialists and Entrepreneurs)
	RSPP indices (Interfax-Era methodology)
	CCI Social Reporting Standard (Chamber of Commerce and Industry)
	Fundamental efficiency ratings (compiled by the environmental and energy rating agency Interfax-ERA)
	Methodology for assessing energy efficiency class from E to A ++ (RERA) (RUSSIAN ENERGY RATING AGENCY)
	Russian Regional Network for Integrated Reporting (RRS)
International methodologies for assessing CS and social performance	Employer Attractiveness Rating NRA (National Rating Agency)
	Dow Jones Sustainability Index (методологияRobecoSam).
	FTSE4GOOD
	Global 100 Index methodology.
	Global Reporting Initiative (GRI) methodology.
	Bloomberg ESG Index methodology.
	DEA (Data Envelopment Analysis)
	KLD (Kinder, Lydenberg and Domini)
	Econometric Impact Index (economic benefit index) proposed by Smith O'Brien.
	Carbon Disclosure Project (CDP) (carbon reporting and performance leaders: Carbon Disclosure Leadership Index, CDLI; Carbon Performance Leadership Index, CPLI)
Methodologies for assessing CS and social performance with industry specifics	Oil and Gas Industry Guidance on Voluntary Sustainability Reporting. IPIECA/API (in the field of oil, gas production)
	Rating agency Tomorrow’s Value Rating (TVR) (oil, gas)
	Equitable Origin has released the EO100 Standard (in the field of oil, gas)
	Rating of openness of oil and gas companies in the field of environmental responsibility (organized by KREON Group)
	Rating of the openness of mining and metallurgical companies in Russia in the field of environmental responsibility
Methodologies and approaches for assessing social performance:	SIA (Social Impact Assessment),
	SRA (Social Return Assessment),
	SCBA (Social Costs-Benefit Analysis),
	SVA (Stakeholder Value Added)
	Total Impact Measurement and Management (PWC-developer, approach to assessing the impact of business on the economy, society and the environment, as well as the tax contribution of the company)
	Coalition for Environmentally Responsible Economies (CERES)
Social Reporting Standards	Institute for Social and Ethical Responsibility (ISEA)
	AA1000 KCO Institute of Social and Ethical Accountability
	SA8000 Social Accountability International
Methodologies of Russian researchers for assessing performance (more than 100)	Social Responsibility Guide ISO 26000
	Borzakov; Skliar E., Zverkovich I.; Penc I., Saprykina O.; D. A. Endovitsky, Ponomarenko T.V., Marinina O.A. etc.

The effectiveness of CS is assessed by two final indicators. The first indicator is an aggregated index for three groups of factors to assess the ratings of companies relative to the performance of the best company. The second indicator is an assessment of the dynamics within the company relative to the previous values of the indicators of corporate social responsibility.

Methodology: analysis of CS assessment methods; systematization of assessment methods for mining companies in order to identify limitations and opportunities for application of CS assessment methods in mining companies; development of a method for CS assessment in order to determine the achieved level and dynamics of CS indicators in terms of the target industry indicators; assessment and analysis of CS results using data from oil companies.

We selected oil and gas companies, on the one hand, due to an important role of the oil and gas industry for the Russian economy in general and for the regions of operation, in particular, plus the ability to use high-quality secondary sources of available and accessible information and, on the other hand, because of a significant environmental impact of such companies. An important factor for selection of oil and gas companies is the fact that, for example, in Gazprom PJSC, the number of employees makes up almost half of the total number of employees in the mining sector. We formed a database using the reports of oil and gas companies published on the Russian Union of Industrialists and Entrepreneurs website, in particular, reports on sustainable development. We assessed CS taking data from six largest Russian oil and gas companies: PJSC NK Rosneft, PJSC Gazprom, PJSC NOVATEK, PJSC Tatneft, PJSC Lukoil and PJSC Surgutneftegas, over 5 years ([National Register 2020](#)).

In order to comprehensively assess the CS level of oil and gas companies and the degree of progress towards the target industry indicators, we developed and applied a method to assess the achieved level and dynamics of changes in CS indicators. The choice of oil and gas companies for the study was based on the availability of sustainability reports that needed to be used to collect source data. These oil and gas companies are among the biggest ones in Russia. Three of them are controlled by the government and another three are private.

3. Results

Based on an analysis of CS concepts, existing methods, recommendations given in the GRI G4 standard and disclosure requirements concerning non-financial information, a set of indicators reflecting the specific features of oil and gas companies was selected as the initial data for developing a methodology for CS assessment.

The choice of indicators stems from the fact that it is essential to meet two requirements: to assess impact in three spheres (economy, ecology and environment) and to characterize the long-term development of a company (by analyzing revenue, profitability and natural resource assets).

The indicators are grouped by three areas (environmental, social and economic) and divided into two groups based on the desired trends ([ESG 2019](#); [Rate the Raters 2020](#); [Corporate 2018](#); [Borzakov 2016](#); [Ponomarenko et al. 2020](#)):

- indicators that should be minimized: energy consumption per unit, water consumption, production waste, occupational injury frequency rate;
- indicators that should be maximized: average cost-to-revenue ratio, revenues, oil and gas reserve life, investment in environmental protection and costs associated with supporting local communities.

Information for developing a system of CS (Corporate Sustainability) assessment indicators was obtained from several sources: CSR (Corporate Social Responsibility) and SD (Sustainable Development) reports, annual corporate reports and annual financial reports.

Indicators (R_i^t), their desired trends and information sources are shown in Table 3.

Table 3. Set of CS assessment indicators. Source: compiled by the authors.

Sphere/Indicator (R_i^t)	Information Source	Desired Trend
Social sphere		
- occupational injury frequency rate	CSR and SD reports	→min
- growth in costs associated with supporting local communities, RUB USD, EUR) billion	CSR and SD reports	→max
- environmental protection costs, RUB (USD, EUR) billion	CSR and SD reports	→max
Environmental sphere		
- energy consumption per unit, RUB/RUB; RUB/t (\$, €)	CSR and SD reports	→min
- water consumption per unit, m ³ /t; m ³ /RUB (\$, €)	CSR and SD reports	→min
- production waste, million tons	CSR and SD reports	→min
Economic sphere		
- average cost-to-revenue ratio	Annual report	→max
- revenues, RUB billion (USD, EUR)	Financial report	→max
- oil and gas reserve life, years	Annual report	→max

3.1. Calculating the Aggregate CS Index

Aggregation is carried out based on equal weights and assessments are given in points to ensure that parameters which differ in units of measurement can be compared. The aggregate CS index is meant for ranking companies in relation to the best one in the industry. To find the aggregate CS index, it is necessary to replace quantitative indicators (R_i^t) with points.

Scores (P_i^t) of indicators (R_i^t) are determined proportionally to the maximum value of i -indicator of CS assessment in t -year. The maximum value of the indicator corresponds to the maximum score of 10 points.

Assessment of the achieved CS level is determined by summing up the scores of CS assessment indicators (AP_i^t):

$$AP_i^t = \sum P_i^t \tag{1}$$

where P_i^t —is the score of i -indicator of CS assessment in t -year.

Points (P_i^t) are assigned to the indicators (R_i^t) in proportion to the maximum (minimum) value of the i -th indicator of the top company in the industry. The maximum or minimum value (depending on the desired trend) corresponds to the maximum score, which is 10 points.

3.2. Assessment of Changes in Companies' CS Indicators

The assessment of changes in CS is based on information on the companies' CS indicators covering a period of three years. Taking each company's indicators separately, change (PC_i^t) (deviation) (+/−) relative to the previous period is found.

$$PC_i^t = AP_i^{t+1} - AP_i^t \tag{2}$$

where AP_i^t is the value of the score of i -indicator of CS assessment in t -year.

The absolute change is then converted to relative change, which will be presented in percentage. In order to analyze indicators in dynamics, we calculated the Percentage change (PC_i^t) for each indicator, which has a certain number of scores (from 1 to 10) by the scale (see Table 4). The rating of sustainable development indicators, given their dynamics, is determined by summing up the scores ($\sum E_i^t$) of each indicator in a year.

Table 4. Score scale. Source: compiled by the authors.

Percentage change (PC_i^t)	1–10	11–20	21–30	31–40	41–50	51–60	61–70	71–80	81–90	91–100
Point ($\sum E_i^t$)	1 (−1)	2 (−2)	3 (−3)	4 (−4)	5 (−5)	6 (−6)	7 (−7)	8 (−8)	9 (−9)	10 (−10)

The methodology for assessing CSR is presented in Figure 1.

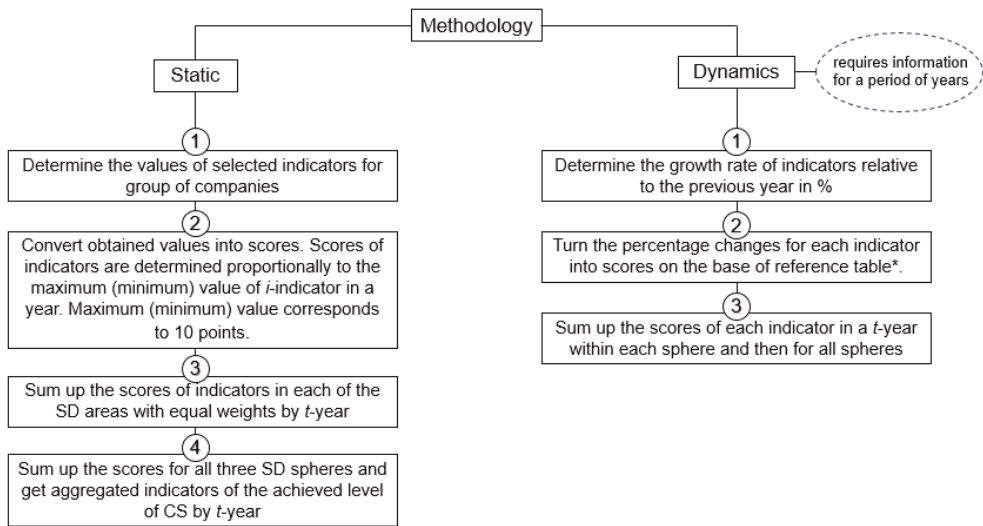

Figure 1. Methodology for assessing corporate social responsibility. Source: compiled by the authors.

To see how this method is applied, we shall consider creation of a system of economic indicators for the three largest Russian oil and gas companies: PJSC NK Rosneft, PJSC Gazprom, PJSC NOVATEK, PJSC Tatneft, PJSC Lukoil, PJSC Surgutneftegaz over 5 years. The final indicators of CSR assessment are shown in the Figures 2 and 3. Intermediate calculation indicators are presented in the Appendix A (Tables A1–A3).

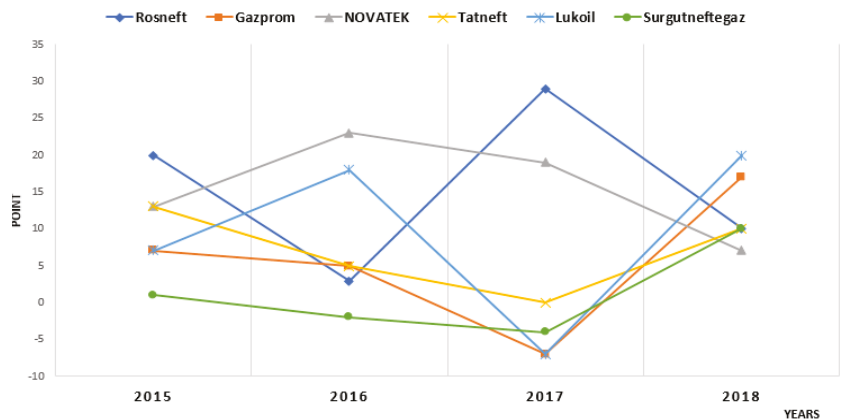

Figure 2. Assessment of the rate of change CS (economic, environmental and social indicators) oil and gas companies on the dynamics of change of indicators.

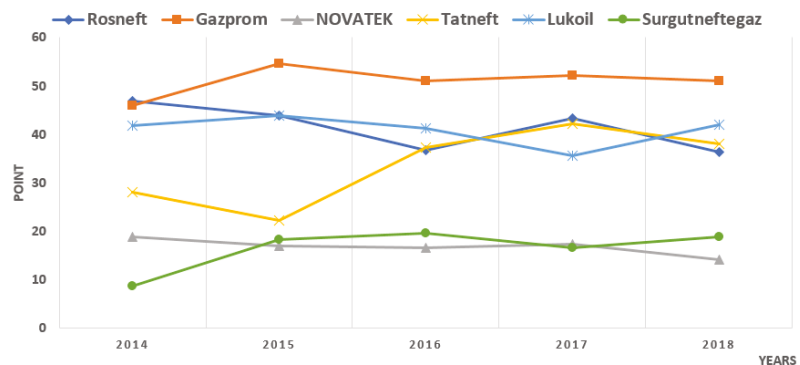

Figure 3. Assessment of the level of CSR (economic, environmental and social indicators) oil and gas companies on the absolute value of the indicators.

When being tested, the methodology showed significant deviations in SD indicators, which means that additional analysis of the results at a qualitative level is required.

According to the final indicator of social corporate sustainability, the company can be ranked in the following order:

- (1) PJSC Gazprom (2018—the level of CSR-41)
- (2) PJSC Lukoil (2018, the level of CSR-38)
- (3) PJSC NK Rosneft (2018—the level of CSR-32)
- (4) PJSC Tatneft (2018—the level of CSR-31)
- (5) PJSC Surgutneftegas (2018—the level of CSR-18)
- (6) PJSC NOVATEK (2018—the level of CSR-8)

All calculations and graphs show that for the companies the dynamics of changes in indicators (rate of change) is differently directed. Within the study period, Gazprom PJSC has had a tendency for increasing indicators; however, the indicator values themselves were minimal compared to other companies. In terms of the achieved CS level among the analyzed companies, the leading position belongs to Lukoil PJSC, with the average score of 38 points. This allows us to conclude that this Lukoil PJSC is the most sustainable (after Gazprom PJSC), because the absolute value of the indicator plays a more important role than the dynamics of its change, since it reflects the actual status of the company by a certain indicator and allows comparing companies with each other.

4. Discussion

As you can see, the leading position in terms of static values is occupied by PJSC Gazprom with a margin of about 28% from its closest competitors (Rosneft and LUKOIL) (in terms of points). The maximum number of scores the company had for the social component, which can be correlated with the scale of implemented social programs and joint activities with the state.

In terms of dynamics, the most effective activity was performed by PJSC NOVATEK, followed by PJSC Rosneft. To ask why Gazprom does not show a leading position here, it should be understood that showing the highest values among all the considered companies, GAZPROM just may not have reserves for noticeable leaps in development.

In the process of evaluating and analyzing the results, we concluded that the methodology requires further work. For example, it would be good to consider the issue of weighting factors and then mechanism for mutual influence of spheres (for example, PJSC Gazprom with 29 points in social sphere has only 1.7 points for the environmental component, which means unstable development). We also aim to work with the technique of estimation in dynamics so that the obtained results can be interpreted more effectively.

The review and analysis of methods for assessing CSR and CS that, despite a great number and variety of methods, they can be classified by the following categories:

1. By the area of research—the methods are aimed at study and assessment of corporate activity areas. Based on this criterion, there are methods focused on assessing environmental sustainability or social component of SD in the CSR system, methods of integrated (socio-environmental) assessment of CSR, integrated methods for assessing CSD combined with the analysis of environmental, social and economic components.
2. By the objectives—the methods are aimed at monitoring of the situation in the areas of research; assessment of social and environmental results of projects or activities of the companies; making company ratings (comparative assessment).
3. By applicable assessment criteria and indicators—the methods for making assessment criteria and indicators include: -quantitative indicators, for example, emissions in assessing environmental impact; cost performance indicators of companies; quantitative indicators for business areas of the company; quality indicators for assessing social and environmental effects; aggregate indicators (indices); score-rating indicators.
4. By sources of information for CS assessment—secondary sources (open); primary sources (special surveys of companies); primary sources (special surveys for local communities).
5. By rapid and detailed assessment of CS—rapid assessment generates an overall idea of socially responsible activities of the company confirmed by facts and non-financial reports and serves as an informational background for subsequent analysis, identification of potential risks and making informed decisions. The list of rapid assessment indicators includes the most important indicators characterizing social, economic and environmental role of the company.

The analyzed methods for CS level assessment have several disadvantages, since they do not take into account many factors affecting oil and gas companies. For example, one of the CSR level assessment methods based on non-financial reporting reflects only dynamics of changes in indicators for a particular company. Thus, the rapid assessment only counts for the rate of change in the indicators used for that method, but it does not compare companies with each other by the achieved CSR level. This fact does not allow for making an objective conclusion regarding the CSR level of the companies.

In order to comprehensively assess the CS level of oil and gas companies and the degree of progress towards the target industry indicators (according to the “Energy Strategy of Russia for the Period until 2030”), we developed and applied a method for assessing the achieved CS level and dynamics of changes in CS indicators.

An analysis of CS assessment methods showed that only the fourth group offers a comprehensive assessment. Methods based on environmental information focus only on the environment. Methods based on social welfare deal with the impact on society. Methods based on CSR predominantly focus on social issues, with environmental ones also taken into account. CS assessment methods cover three areas of sustainable development and three groups of indicators.

Three indicators were selected in each group to create a balanced system of indicators. Thorough consideration was given to the specific features of oil and gas companies. Among the social indicators, three indicators were chosen that reflect social impact and the impact of the company on its employees (data on occupational injuries, Deloitte surveys), the local community (company reports) and the population at the regional and national levels, as they all form a single ecosystem. All the indicators correspond with the stakeholder approach.

Among the environmental indicators, three indicators were chosen that characterize the consumption of key natural resources and the impact on the environment), including energy consumption (as well as CO₂ emissions), water consumption (which is high in oil and gas companies) and waste.

In the economic area, such indicators were chosen as cost-to-revenue ratio as a key indicator of economic performance, revenue as an indicator of the cumulative effect and oil and gas reserve life as a key factor connected with resources.

The choice of all these indicators makes it possible to subsequently trace the relationship between CS and SD at the national level.

A limited combination of indicators was chosen in order to give a brief assessment of the main “outputs” of the company. In this kind of assessment, a number of indicators are not taken into account.

The developed method for CS assessment and can be used by large companies in the analysis and planning of operational and investment activities that ensure achievement of CS goals and growth. Oil and gas companies can use the method for CS assessment to achieve their strategic goals and strengthen their market positions by investing in certain problem areas. In this regard, oil and gas companies are advised to monitor the CS level, effectively manage interaction with various stakeholders and involve the local community in solving environmental and social issues.

In practice, oil and gas companies can use the methodology for benchmarking between both companies and separate spheres based on the values for a particular moment. For example, scores in different CS spheres enable companies to make conclusions about their status and progress.

An interesting feature of the methodology is that it provides for analyzing changes in the company’s indicators in comparison with those of other companies. This is an indirect measure of its competitiveness.

The methodology provides tools for achieving CS goals related to the global SDGs. Many companies discuss the SDGs in their reports but do not assess whether they can be achieved.

The methodology takes into account the resource and stakeholder ideologies.

The limitation of the proposed methodology lies in the fact that additional qualitative analysis is required that will characterize the causes of significant deviations in corporate sustainability indicators. The set of indicators consists of multidirectional SD indicators that are combined into an aggregate index, which makes it difficult to find the reason for such deviations. Another limitation is that companies should provide CSR reports compiled according to the GRI standards since the source data for different companies must be comparable to each other. In addition, comparisons should be made within one industry, for example, oil and gas production, mining metal ores or coal mining as different industries are characterized by different environmental indicators. A survey should be conducted among oil and gas companies to see whether this methodology proves useful in their practice.

The author’s technique presented in the article is truly applicable for the mining industry in general. The special features of the methodology are that we have chosen indicators that characterize the features of the activities of mining companies from many indicators of GRI. Since, to date, many companies do not use GRI indicators in their reports, we have shown the applicability of our methodology to oil and gas companies. Large oil and gas companies report regularly. Coal, gold and copper mining companies publish reports only in fragments. To use the proposed methodology, it is necessary to have the dynamics of indicators, which already creates certain limitations in choosing companies for analysis.

5. Conclusions

1. The main shortcomings of certain CS assessment methods are their static nature; lack of relation of social–environmental results to economic indicators characterizing a dynamic development of the company; lack of feedback from the companies; lack of count for industry specifics and differences in the level of disclosure and quality of information.

2. For oil and gas companies, the set of CS indicators should include indicators reflecting business in harsh climatic conditions, increased injuries, generation of a large amount of various wastes, exploitation of mineral resources, vast economic impact of companies on the regional development, value of GDP and budgets.
3. The method for CS assessment of mining companies is developed taking into account the stakeholder approach, institutional theory, the resource approach and the new theory of corporate sustainability.
4. Analysis of CS indicators allows determining the place of CSR in the system of corporate values, identify the relations between CSR and corporate sustainability, explore the nature of relations with external stakeholders of mining companies and main directions of social programs, analyze the results achieved and the dynamics of the main performance indicators in CS. Comparing mining companies in terms of values and changes in CS indicators by industry reveals problems and creates incentives for further sustainable development of companies.
5. The relevance of the study aimed at assessing corporate sustainable development in oil and gas companies operating stems from the fact that they have significant impact on the environment, the development of areas where they operate and the social landscape, which is accompanied by specific technological, macroeconomic and regulatory conditions for the development of oil and gas fields. Analysis of the integrated reporting showed that the volume of corporate social responsibility of mining companies is different and is characterized by different indicators that reflect the impact of companies on the society: impact on the social, environmental and economic sphere. In the voluntary reporting on sustainable development of the mining companies, CSR monitoring indicators are distributed in the following areas: participation in development, communities, human rights, environmental protection, economic impact, staff development, labor relations and management.
6. Taking into account the purpose of this work to develop a methodology for assessing the CSR of oil and gas companies, the authors proposed the principles and method of assessment. The methodological principles are focused on the specifics of the industry and the long-term development of the company. The methodology contains indicators that allow to assess the impact in three areas (economy, ecology and environment) and characterize the prospects for long-term development of the company (by analyzing revenue, profitability and natural resource assets). The aggregate CS index is meant for ranking companies in relation to the best one in the industry. Assessment of changes in companies' CS indicators determines the dynamics of indicators relative to previous periods for the company.

6. Patents

Program of Corporate Sustainability Rating for Mining Companies: Certificate of registration of the computer program 2021611713, 03.02.2021. Application No. 2021610736 dated 28.01.2021.

Author Contributions: Conceptualization, T.P. and O.M.; methodology, T.P. and O.M.; software, M.N.; validation, T.P. and M.N.; formal analysis, M.N. and O.M.; investigation, T.P. and O.M.; resources, M.N.; writing—original draft preparation, T.P. and O.M.; writing—review and editing, M.N. and O.M.; visualization, O.M., K.K.; funding acquisition, T.P. and M.N. All authors have read and agreed to the published version of the manuscript.

Funding: This research was funded by RFBR and MCESSM, grant number № 19-510-44013\19.

Data Availability Statement: Data available in a publicly accessible repository. The data presented in this study are openly available in (National Register of corporate non-financial reports, 2020 <https://xn--o1aabe.xn--p1ai/activity/social/registr/> (accessed on 6 April 2021)).

Acknowledgments: Special thanks to the following people for providing valuable guidance: Cherepovitsyn A., Ilinova A. A., Savelyeva N.

Conflicts of Interest: The authors declare no conflict of interest the results.

Appendix A

Table A1. Economic, Social and Environmental Indicators of Corporate Sustainability.

Year	Actual Figures										Points		
	PJSC NK Rosneft	PJSC Gazprom	PJSC NOVATEK	PJSC Tatneft	PJSC Lukoil	PJSC Surgutneftegas	PJSC NK Rosneft	PJSC Gazprom	PJSC NOVATEK	PJSC Tatneft	PJSC Lukoil	PJSC Surgutneftegas	
Economic													
average product profitability, %													
2014	19.2	1.54	14.53	20.5	11.4	-	9.37	0.75	7.09	10	5.56	0	
2015	23.8	5	10.6	19.1	9.7	-	10	2.1	4.45	8.03	4.08	0	
2016	25	6	29.29	18.3	15	76	3.29	0.79	3.85	2.41	1.97	10	
2017	22.6	4	16.23	18.2	8.1	16.6	10	1.77	7.18	8.05	3.58	7.35	
2018	24.8	8	15.68	23.2	10.25	54.7	4.53	1.46	2.87	4.24	1.87	10	
revenue, billion rubles													
2014	5503	5589.8	357.6	476.36	1710	-	9.84	10	0.64	0.85	3.06	0	
2015	5150	6073.3	475.3	552.712	1877	1020.8	8.48	10	0.78	0.91	3.09	1.68	
2016	4988	6111.1	537.5	580.127	5227	1002.6	8.16	10	0.88	0.95	3.77	1.64	
2017	6011	6546.1	583	681.159	5936.7	1175	9.18	10	0.89	1.04	9.07	1.79	
2018	8238	8224.2	832	910.534	8035.9	1556	10	9.98	1.01	1.11	9.75	1.89	
availability of mineral resources, years													
2014	16.6	51.6	27.5	32	20.6	0	3.21	10	5.33	6.15	4	0	
2015	18.2	49.6	24.6	32	18.9	0	3.67	10	4.96	6.45	3.81	0	
2016	19.3	54.1	23.8	30.4	20.4	0	3.57	10	4.4	5.62	3.77	0	
2017	19.4	49.5	29.4	30	19	0	3.92	10	5.94	6.06	3.84	0	
2018	19.9	47.5	28.8	31.4	18.9	0	4.19	10	6.06	6.61	3.98	0	
Social													
frequency factor of industrial injuries													
2014	0.33	0.18	0.4	0.1	0.13	-	3.03	5.56	2.5	10	7.69	0	
2015	0.327	0.17	0.5	0.3	0.28	-	5.2	10	3.4	5.67	6.07	0	
2016	0.21	0.16	0.3	0.14	0.21	-	6.67	8.75	4.67	10	6.67	0	
2017	0.36	0.11	1.27	0.1	0.19	-	2.78	9.09	0.79	10	5.26	0	
2018	0.41	0.17	0.79	0.14	0.19	-	3.41	8.24	1.77	10	7.37	0	
increased costs of local community support, million rubles													
2014	8000	46,429	727	135.87	290.6	-	1.72	10	0.16	0.03	0.06	0	
2015	9000	32,485	1000	165.7	304.9	-	2.77	10	0.31	0.05	0.09	0	
2016	11,000	35,516	1324	195.65	304.3	-	3.1	10	0.37	0.06	0.09	0	
2017	19,000	34,461	1377	281.64	341.9	-	5.51	10	0.4	0.08	0.1	0	
2018	23,000	42,789	2000	257	384	-	5.38	10	0.47	0.06	0.09	0	
costs and investment into environmental protection, billion rubles													
2014	36.93	48.98	0.63	5.8	59	18.58	6.26	8.3	0.11	0.98	10	3.15	
2015	44.65	49.71	0.77	5.7	48	17.89	8.98	10	0.15	1.15	9.66	3.6	
2016	47.14	57.47	1.19	13.29	53	17.73	8.2	10	0.21	2.31	9.22	3.09	
2017	67.24	70.82	2.06	13.63	23	21.1	9.49	10	0.29	1.92	3.25	2.98	
2018	45.61	68.96	2.4	11.68	58	17.4	6.61	10	0.35	1.69	8.41	2.52	
Environmental													
water consumption per unit of production/activity; m3/tons													
2014	1.159	4.895	1.347	-	0.4	1.49	3.45	0.82	2.97	0	10	2.68	
2015	1.467	4.511	1.716	-	0.5	1.63	3.41	1.11	2.91	0	10	3.07	
2016	1.679	4.538	2.701	1.018	0.6	1.65	3.57	1.32	2.22	5.89	10	3.64	
2017	2.26	4.523	2.779	1.005	0.5	1.418	2.21	1.11	1.8	4.98	10	3.53	
2018	2.28	4.28	2.993	1.134	0.5	1.408	2.19	1.17	1.67	4.41	10	3.55	
mass of waste generated, thousand tons													
2014	208	4831	-	-	1437	716.1	10	0.43	0	0	1.45	2.9	
2015	5393	4954	-	-	1015	725.8	10	1.35	1.47	0	7.15	10	
2016	5377	4289	-	92.7	1033	714	0.17	0.22	0	10	0.9	1.3	
2017	6325	4130	-	80.1	1434	837.66	0.13	0.19	0	10	0.56	0.96	
2018	7155	3555	-	78.6	1529	824.49	0.11	0.22	0	10	0.51	0.95	

Table A2. Total Company Ratings by years (Statics).

Year	PJSC NK Rosneft	PJSC Gazprom	PJSC NOVATEK	PJSC Tatneft	PJSC Lukoil	PJSC Surgutneftegas
Economic						
2014	22.42	20.75	13.06	17	12.62	0
2015	22.15	22.1	10.19	15.9	10.98	1.68
2016	15.02	20.79	9.13	8.98	14.29	11.64
2017	23.1	21.77	14.01	15.15	16.49	9.14
2018	18.72	21.44	9.94	11.96	15.6	11.89
Total	101.41	106.85	56.33	68.48	69.98	34.35
Social						
2014	11.01	23.86	2.76	11.01	17.75	3.15
2015	16.95	30	3.86	6.86	15.82	3.6
2016	17.97	28.75	5.25	12.37	15.97	3.09
2017	17.79	29.09	1.48	12.01	8.61	2.98
2018	15.4	28.24	2.59	11.75	15.87	2.52
Total	79.12	139.94	15.94	54	74.02	15.34
Environmental						
2014	13.45	1.25	2.97	0	11.45	5.59
2015	4.75	2.57	2.91	0	17.15	13.07
2016	3.75	1.54	2.22	15.89	10.9	4.93
2017	2.34	1.3	1.8	14.98	10.56	4.48
2018	2.3	1.39	1.67	14.41	10.51	4.5
Total	26.59	8.05	11.57	45.28	60.57	32.57

Table A3. Total Company Ratings by years (Dynamics).

Year	Actual Figures						Growth Rate (Points)					
	Rosneft	Gazprom	NOVATEK	Tatneft	Lukoil	Surgutneftegaz	Rosneft	Gazprom	NOVATEK	Tatneft	Lukoil	Surgutneftegaz
Economic												
average product profitability, %												
2014	19.2	1.54	14.53	20.5	11.4	-	-	-	-	-	-	-
2015	23.8	5	10.6	19.1	9.7	-	0.24	2.25	-0.27	-0.07	-0.15	-
2016	25	6	29.29	18.3	15	76	0.05	0.20	1.76	-0.04	0.55	-
2017	22.6	4	16.23	18.2	8.1	16.6	-0.10	-0.33	-0.45	-0.01	-0.46	-0.78
2018	24.8	8	15.68	23.2	10.25	54.7	0.10	1.00	-0.03	0.27	0.27	2.30
revenue, billion rubles												
2014	5503	5589.8	357.6	47.36	1710	-	-	-	-	-	-	-
2015	5150	6073.3	475.3	552.712	1877	1020.8	-0.06	0.09	0.33	0.16	0.10	-
2016	4988	6111.1	537.5	580.127	5227	1002.6	-0.03	0.01	0.13	0.05	1.78	-0.02
2017	6011	6546.1	583	681.159	5936.7	1175	0.21	0.07	0.08	0.17	0.14	0.17
2018	8238	8224.2	832	910.534	8035.9	1556	0.37	0.26	0.43	0.34	0.35	0.32
availability of mineral resources, years												
2014	16.6	51.6	27.5	32	20.6	0	-	-	-0.11	0.00	-	-
2015	18.2	49.6	24.6	32	18.9	0	0.10	-0.04	-0.03	-0.05	-0.08	-
2016	19.3	54.1	23.8	30.4	20.4	0	0.06	0.09	-0.03	-0.05	0.08	-
2017	19.4	49.5	29.4	30	19	0	0.01	-0.09	0.24	-0.01	-0.07	-
2018	19.9	47.5	28.8	31.4	18.9	0	0.03	-0.04	-0.02	0.05	-0.01	-
Social												
frequency factor of industrial injuries												
2014	0.33	0.18	0.4	0.1	0.13	-	-	-	-	-	-	-
2015	0.327	0.17	0.5	0.3	0.28	-	-0.01	-0.06	0.25	2.00	1.15	-
2016	0.21	0.16	0.3	0.14	0.21	-	-0.36	-0.06	-0.40	-0.53	-0.25	-
2017	0.36	0.11	1.27	0.1	0.19	-	0.71	-0.31	3.23	-0.29	-0.10	-
2018	0.41	0.17	0.79	0.14	0.19	-	0.14	0.55	-0.38	0.40	0.00	-
increased costs of local community support, million rubles												
2014	8000	46,429	727	135.87	290.6	-	-	-	-	-	-	-
2015	9000	32,485	1000	165.7	304.9	-	0.13	-0.30	0.38	0.22	0.05	-
2016	11,000	35,516	1324	195.65	304.3	-	0.22	0.09	0.32	0.18	0.00	-
2017	19,000	34,461	1377	281.64	341.9	-	0.73	-0.03	0.04	0.44	0.12	-
2018	23,000	42,789	2000	257	384	-	0.21	0.24	0.45	-0.09	0.12	-

Table A3. Cont.

Year	Actual Figures						Growth Rate (Points)					
	Rosneft	Gazprom	NOVATEK	Tatneft	Lukoil	Surgutneftegaz	Rosneft	Gazprom	NOVATEK	Tatneft	Lukoil	Surgutneftegaz
costs and investment into environmental protection, billion rubles												
2014	36.93	48.98	0.63	5.8	59	18.58	-	-	-	-0.2	-0.19	-0.04
2015	44.65	49.71	0.77	5.7	48	17.89	0.21	0.01	0.22	-	-	-
2016	47.14	57.47	1.19	13.29	53	17.73	0.06	0.16	0.55	1.33	0.10	-0.01
2017	67.24	70.82	2.06	13.63	23	21.1	0.43	0.23	0.73	0.03	-0.57	0.19
2018	45.61	68.96	2.4	11.68	58	17.4	-0.32	-0.03	0.17	-0.14	1.52	-0.18
Environmental												
water consumption per unit of production/activity; m3/tons												
2014	1.159	4.895	1.347	-	0.4	1.49	-	-	-	-	-	-
2015	1.467	4.511	1.716	-	0.5	1.63	0.27	-0.08	0.27	-	0.25	0.09
2016	1.679	4.538	2.701	1.018	0.6	1.65	0.14	0.01	0.57	-	0.20	0.01
2017	2.26	4.523	2.779	1.005	0.5	1.418	0.35	0.00	0.03	-0.01	-0.17	-0.14
2018	2.28	4.28	2.993	1.134	0.5	1.408	0.01	-0.05	0.08	0.13	0.00	-0.01
mass of waste generated, thousand tons												
2014	208	4831	-	-	1437	716.1	-	-	-	-	-	-
2015	5393	4954	-	-	1015	725.8	24.93	0.03	-	-	-0.29	0.01
2016	5377	4289	-	92.7	1033	714	0.00	-0.13	-	-	0.02	-0.02
2017	6325	4130	-	80.1	1434	837.66	0.18	-0.04	-	-0.14	0.39	0.17
2018	7155	3555	-	78.6	1529	824.49	0.13	-0.14	-	-0.02	0.07	-0.02

References

- A Guide. 2012. A Guide to Social Return on Investment. Available online: <http://www.socialvalueuk.org/app/uploads/2016/03/The%20Guide%20to%20Social%20Return%20on%20Investment%202015.pdf> (accessed on 28 June 2020).
- Berman, Shawn, Andrew C. Wicks, Suresh Kotha, and Thomas M. Jones. 1999. Does stakeholder orientation matter? The relationship between stakeholder management models and firm performance. *Academy of Management Journal* 42: 488–506.
- Blagov, Yu E. 2011. *Corporate Social Responsibility: The Evolution of the Concept*, 2nd ed. Saint Petersburg: Higher School of Management Publishing House, 272p.
- Borzakov, D. V. 2016. Control and Assessment of Corporate Social Responsibility in the Management of Organizations. Ph.D. dissertation, Voronezh South-West State University, Voronezh, Russia.
- Carayannis, Elias G., Alina Ilinova, and Alexey Cherepovitsyn. 2021. The Future of Energy and the Case of the Arctic Offshore: The Role of Strategic Management. *Journal of Marine Science and Engineering* 9: 134. [CrossRef]
- CDP. 2015. Climate Change. Information Request. Available online: <https://www.cpr.ca/en/about-cp-site/Documents/cdp-program-submission-2015.pdf> (accessed on 28 June 2020).
- Cherepovitsyn, Aleksey E., Svetlana A. Lipina, and Olga O. Evseeva. 2018. Innovative approach to the development of mineral raw materials of the arctic zone of the Russian federation. *Journal of Mining Institute* 232: 438.
- Corporate. 2018. Corporate Sustainability Assessment & Corporate Public Reporting Annelies Poolman. Available online: <https://zebra-group.ru/download/ru/news/news-70/news-image-id-70-content-1.pdf> (accessed on 7 March 2021).
- Dowling Grahame. 2013. The Curious Case of Corporate Tax Avoidance: Is it Socially Irresponsible? *Journal of Business Ethics* 124: 173–84.
- Drucker, Peter F. 1984. The new meaning of corporate social responsibility. *California Management Review* 26: 53–63. [CrossRef]
- Emerson, Jed, Jay Wachowicz, and Suzi Chun. 2000. Social Return Social Return on Investment: On Investment. Exploring Exploring Aspects of Aspects of Value Creation Value Creation in the Nonprofit in the Nonprofit Sector. Available online: <https://hbswk.hbs.edu/archive/social-return-on-investment-sroi-exploring-aspects-of-value-creation> (accessed on 28 June 2020).
- Endovickij, D. A., I. V. Panina, and M. V. Ponkratova. 2017. Analiz sushchnosti korporativnoj ustojchivosti kak reakcii na civilizacionnyye izmeneniya. *Ekonomicheskij Analiz: Teoriya i Praktika* 16: 1043–60.
- Endovitsky, D. A., L. M. Nikitina, and D. V. Borzakov. 2014. Assessment of corporate social responsibility of Russian companies based on a comprehensive analysis of non-financial reporting. *Economic Analysis: Theory and Practice* 8: 2–10.
- Epstein, Marc J., and Marie-Jose Roy. 2003. Making the business case for sustainability. Linking social and environmental actions to financial performance. *Journal of Corporate Citizenship* 9: 79–96. [CrossRef]
- ESG. 2019. Expert Views on ESG Ratings. Available online: <https://sustainability.com/our-work/reports/rate-raters-2019> (accessed on 7 March 2021).
- ESG Factors in Investment, MIRBIS. 2019. Available online: <https://www.pwc.ru/ru/sustainability/assets/pwc-responsible-investment.pdf> (accessed on 7 March 2021).
- ESG Rating. 2020. Available online: <https://www.msci.com/esg-ratings> (accessed on 28 June 2020).
- Freeman, Edward. 1984. *Stakeholder Management: A Stakeholder Approach*. Marshfield: Pitman Publishing, p. 292.
- Global. 2014. Global Competitiveness Report 2013–2014. Available online: http://www3.weforum.org/docs/WEF_GlobalCompetitivenessReport_2013-14.pdf (accessed on 28 June 2020).

- GOST R 54598.1. 2015. Management of Sustainable Development. Part 1. Guide 2016. Available online: <http://docs.cntd.ru/document/1200127235> (accessed on 28 June 2020).
- GOST R ISO 20121. 2014. Systems of Management of a Sustainable Development. Requirements and Practical Guidance on Management of Stability of Events. Available online: <http://docs.cntd.ru/document/1200113801> (accessed on 28 June 2020).
- GOST R ISO 9004. 2010. Managing for the Sustained Success of an Organization. A Quality Management Approach. Available online: <http://docs.cntd.ru/document/gost-r-iso-9004-2010> (accessed on 28 June 2020).
- Halme, Minna, and Juha Laurila. 2009. Philanthropy, integration or innovation? Exploring the financial and societal outcomes of different types of corporate responsibility. *Journal of Business Ethics* 84: 325–39. [CrossRef]
- Ilinova, A., A. Chanysheva, and V. Solovyova. 2020. Arctic oil and gas offshore projects: How to forecast their future. Paper presented at IOP Conference Series: Earth and Environmental Science, St. Petersburg, Russia, March 18–19.
- International Integrated Reporting Council ‘IIRC’. 2021. Available online: <https://integratedreporting.org/wp-content/uploads/2021/01/InternationalIntegratedReportingFramework.pdf> (accessed on 7 March 2021).
- ISS-oekom. 2019. Corporate Rating. Available online: https://www.aiib.org/en/treasury/_common/_download/oekomCompanyReport_2019-5-3.pdf (accessed on 28 June 2020).
- Ivanova, D. 2020. Risk management and its contribution to sustainable development of mining enterprises. *Scientific and Practical Studies of Raw Material Issues* 2020: 182–91.
- Ivashkovskaya, I. V. 2009. Modelirovanie Stoimosti Kompanii. In *Strategicheskaya Otvetstvennost’ Sovetov Direktorov*. Moscow: INFRA-M.
- Johnson, H. 2003. Does it pay to be good? Social responsibility and financial performance. *Business Horizons* 46: 34–40. [CrossRef]
- Kanaeva, O. A. 2018. Social’nye imperativy ustojchivogo razvitiya. *Vestnik SPbGU. Ekonomika* 34: 26–58.
- Kirsanova, Natalia, Olga Lenkovets, and Muhammad Hafeez. 2020. Issue of Accumulation and Redistribution of Oil and Gas Rental Income in the Context of Exhaustible Natural Resources in Arctic Zone of Russian Federation. *Journal of Marine Science and Engineering* 8: 1006. [CrossRef]
- Klimova, Nina I., Dina Kh Krasnoselskaya, and Dilya R. Khamzina. 2018. An empirical study on the relationships between sales revenue of oil company and industry specific and exogenous characteristics. *Journal of Applied Economic Sciences* 8: 2261–68.
- Larsena, Sanne Vammen, Anne Merrild Hansen, and Helle Nedergaard Nielsen. 2018. The role of EIA and weak assessments of social impacts in conflicts over implementation of renewable energy policies. *Energy Policy* 115: 43–53. [CrossRef]
- LBG Model. 2017. The LBG Model—A GLOBAL VALUE Tool Showcase. Technical Report. Available online: https://www.researchgate.net/publication/323935384_The_LBG_Model_-_a_GLOBAL_VALUE_tool_showcase (accessed on 28 June 2020).
- Leadership GRI SRS. 2013. Available online: <https://www.globalreporting.org/standards/gri-standards-download-center/consolidated-set-of-gri-standards/> (accessed on 7 March 2021).
- Lingane, Alison, and Sara Olsen. 2004. Guidelines for social return on investment. *California Management Review* 46: 116–35. [CrossRef]
- Lipina, Svetlana A., Lina K. Bocharova, and Lyubov A. Belyaevskaya-Plotnik. 2018. Analysis of Government Support Tools for Mining Companies in the Russian Arctic Zone. *Zapiski Gornogo Instituta* 230: 217–22. [CrossRef]
- Litvinenko, Vladimir S., Pavel S. Tsvetkov, Mikhail V. Dvoynikov, and Georgii V. Buslaev. 2020. Barriers to implementation of hydrogen initiatives in the context of global energy sustainable development. *Journal of Mining Institute* 244: 428–38. [CrossRef]
- Manning, Matthew, Shane D. Johnson, Nick Tilley, Gabriel T. W. Wong, and Margarita Vorsina. 2016. *Cost-Benefit Analysis (CBA) Economic Analysis and Efficiency in Policing, Criminal Justice and Crime Reduction: What Works?* Berlin/Heidelberg: Springer, pp. 35–50.
- Margolis, Joshua D., and James P. Walsh. 2003. Misery Loves Companies: Rethinking Social Initiatives by Business. *Administrative Science Quarterly* 48: 268–305. [CrossRef]
- Montiel, Ivan, and Javier Delgado-Ceballos. 2014. Defining and Measuring Corporate Sustainability: Are We There Yet? *Organization and Environment* 27: 113–39. [CrossRef]
- National Register. 2020. National Register of Corporate Non-Financial Reports. Available online: <https://xn--o1aabe.xn--p1ai/activity/social/registr/> (accessed on 7 March 2021).
- Nedosekin, Aleksei O., Elena I. Rejshahrit, and Aleksandr N. Kozlovskiy. 2019. Strategic Approach to Assessing Economic Sustainability Objects of Mineral Resources Sector of Russia. *Journal of Mining Institute* 237: 354–60. [CrossRef]
- Novikova, Natalya. 2020. Pipeline Neighbors: How Can We Avoid Conflicts? *Resources* 9: 13. [CrossRef]
- Pence, I. Sh, and S. A. Furs. 2008. *Corporate Governance in Modern Russian Industry: State and Factors of Improvement*. Moscow: LLC “Nedra Communications Ltd.”, p. 120.
- Ponomarenko, Tatyana, Marina Nevskaya, and Oksana Marinina. 2020. An Assessment of the Applicability of Sustainability Measurement Tools to Resource-Based Economies of the Commonwealth of Independent States. *Sustainability* 12: 5582. [CrossRef]
- Prokopov, F., and E. Feoktistova. 2008. *Bazovye Indikatory Rezul’tativnosti. Rekomendacii po Ispol’zovaniyu v Praktike Upravleniya i -Korporationoj Nefinansovoj Otchetnosti*. Moscow: RSPP, 68p.
- Rahdari, Amir Hossein, and Ali Asghar Anvary Rostamy. 2015. Designing a general set of sustainability indicators at the corporate level. *Journal of Cleaner Production* 108: 757–71. [CrossRef]
- Rate the Raters. 2020. Investor Survey and Interview Results. Available online: <https://sustainability.com/wp-content/uploads/2020/03/sustainability-ratetheraters2020-report.pdf> (accessed on 7 March 2021).

- RepRisk Provides ESG. 2014. Intelligence for Dow Jones Sustainability Indices. Institutional Asset Manager. Available online: <https://www.businesswire.com/news/home/20140910005040/en/RepRisk-ESG-Intelligence-Dow-Jones-Sustainability-Indices> (accessed on 28 June 2020).
- Rudakov, Marat, Elena Gridina, and Jürgen Kretschmann. 2021. Kretschmann, Risk-based thinking as a basis for efficient occupational safety management in the mining industry. *Sustainability* 13: 470. [CrossRef]
- Saprykina, O. A. 2012. Multilevel assessment of the company's performance in the field of corporate social responsibility. Transport business in Russia. *Management* 5: 74–78.
- Sklyar, E. N., and I. O. Zverkovich. 2007. Metodicheskie aspekty upravleniya razvitiem sotsialnogo potentsiala promyshlennyh predpriyatij. *Creative Economy* 1: 74–81.
- Smol, Marzena, Paulina Marcinek, Joanna Duda, and Dominika Szoldrowska. 2020. Importance of Sustainable Mineral Resource Management in Implementing the Circular Economy (CE) Model and the European Green Deal Strategy. *Resource* 9: 55. [CrossRef]
- Szewrański, Szymon, and Jan K. Kazak. 2020. Socio-Environmental Vulnerability Assessment for Sustainable Management. *Sustainability* 12: 7906. [CrossRef]
- Tulaeva, Svetlana A., Maria S. Tysiachniouk, Laura A. Henry, and Leah S. Horowitz. 2019. Horowitz. Globalizing Extraction and Indigenous Rights in the Russian Arctic: The Enduring Role of the State in Natural Resource Governance. *Resources* 8: 179. [CrossRef]
- Vasilev, Yurii, Polina Vasileva, and Anna Tsvetkova. 2019. International review of public perception of ccs technologies. Paper presented at 19th International Multidisciplinary Scientific GeoConference SGEM, Albena, Bulgaria, June 28–July 7; vol. 19, pp. 415–22. [CrossRef]
- WBCSD. 2017. Measuring Impact Framework. Available online: <https://www.wbcsd.org/Programs/People/Social-Impact/Resources/WBCSD-Measuring-Impact> (accessed on 28 June 2020).
- Wells, Louis T., Jr. 1975. Social Cost/Benefit Analysis for MNCs, Harvard Business Review. Available online: <https://hbr.org/1975/03/social-costbenefit-analysis-for-mncs> (accessed on 28 June 2020).
- Wong, Christina, Aiste Brackley, and Erika Petroy. 2019. Rate the Raters 2019: Expert Views on ESG Ratings February. Available online: <https://www.sustainability.com/globalassets/sustainability.com/thinking/pdfs/sa-ratetheraters-2019-1.pdf> (accessed on 7 March 2021).

Article

Environmental Exigencies and the Efficient Voter Rule

David A. Anderson

Department of Economics and Finance, Centre College, 600 W. Walnut St., Danville, KY 40422, USA; anton42@adelphia.net

Received: 15 October 2020; Accepted: 12 November 2020; Published: 17 November 2020

Abstract: Externality problems hinder solutions to existential threats, including climate change and mass extinction. To avert environmental crises, policymakers seek mechanisms that align private incentives with societal exigencies. Successful solutions bring individuals to internalize the broad repercussions of their behavior. In some cases, privatization, Coasian bargaining, or Pigouvian taxes effectively place the weight of externalities on the relevant decision makers. Yet, the available remedies often fail to provide satisfactory outcomes, and inefficiencies persist in the markets for energy, transportation, and manufactured goods, among others. This article explains how a simple voting mechanism can achieve socially optimal decisions about many of the innumerable externality problems that remain.

Keywords: externalities; social cost; environmental protection; efficient voter rule

JEL Classification: G50

1. Introduction

Private decisions about environmental protection are fraught with externality problems, while public decisions are vulnerable to special interests and incomplete information. Trends in resource degradation and climate change continue at alarming rates despite considerable attention from economists over the past century. Coase (1960) advanced the theorem that private bargaining will achieve socially optimal resolutions to externality problems when property rights are clearly defined and transaction costs are negligible. The bargaining approach, like several others discussed below, works under some circumstances and fails under others. Progress toward efficiency on environmental fronts requires the identification of additional, complementary means of addressing externalities. This article advances voting as a straightforward approach to efficient decision-making that is useful in situations not well served by other approaches. Like Coase's solution of bargaining, voting is a familiar practice for other purposes; what is novel is substantiation that under appropriate conditions, the practice yields socially optimal resolutions to pressing policy dilemmas.

Externality problems arise when some of the effects of a decision are felt beyond, or external to, the person making the decision. In that case, the decision maker's private benefit or cost—that which is internalized by the decision maker—differs from the benefit or cost for all of society. Social efficiency is achieved when actions are carried out if and only if the benefit to society exceeds the cost to society, thereby maximizing the net gains for society. Socially inefficient decisions about environmental protection and resource conservation are expected when the private cost falls between the private benefit and the social benefit. Consider a \$100 expenditure on tree seedlings that would provide a \$50 benefit to the consumer by increasing the value of the consumer's property, and a \$200 benefit to society by providing a carbon sink and beauty for passersby to enjoy. The consumer would decide against the expenditure because $\$50 < \100 , while the socially optimal decision would be to purchase the seedlings because $\$100 < \200 . The consumer would make the best decision for society if the consumer internalized the \$150 benefit the purchase conferred on others. To that end, policymakers seek to align

private incentives with broader repercussions, such that decision makers weigh the social marginal benefit of each decision against the associated social marginal cost. Legislators in the United States and elsewhere currently establish environmental policies using deliberative processes whose influences can depart from that criterion for allocative efficiency (EPA 2020). On a global scale, the private disregard of external costs can fuel environmental crises including air and water pollution and climate change (Zhang and Wang 2017).

Buchanan and Tullock's (1962) seminal work shows how voting leads to outcomes in the public interest. Anderson (2011) explains how voting can elicit efficient decisions on topics ranging from community requirements for septic systems to wine consumption by a group that is splitting the check at a restaurant. The present article expands on those findings and highlights the power of a referendum—a simple up or down vote on a contemplated action—to navigate decisions about externalities and maximize the resulting net benefits for society.

The social efficiency of a referendum on environmental policy can be summarized by what we shall refer to as the efficient voter rule: A vote among fully informed parties on the provision of a uniformly distributed positive externality at a given cost per party will reveal the socially efficient outcome, regardless of the amount of the externality attributable to each party. The rule applies equivalently to the abolishment of negative externalities.

The efficient voter rule extends to externality problems beyond environmental issues. For example, the rule suggests that when the citizens of Tuscon, Arizona, voted on whether to use cameras to detect drivers who failed to obey traffic signals (Smith 2015), the outcome was socially efficient. Likewise, decisions about whether to mandate vaccines during a pandemic would be efficient if citizens paid the same price for vaccines and received equivalent benefits from broad immunity. The purpose of this article is to explain how and why the rule applies to critical environmental policy decisions.

Section 2 of this article provides a review of the related literature. Section 3 explains the theoretical foundation for the efficient voter rule. Section 4 discusses further applications of the rule. Section 5 concludes the paper.

2. Literature Review

The previous literature on externalities offers several approaches that are effective under particular circumstances. Pigou (1932) describes how taxes and subsidies can cause decision makers to internalize negative and positive externalities, respectively. Pigouvian solutions can lead to efficient decisions, the caveat being that policymakers need full information on the marginal external cost or marginal external benefit involved in order to establish the appropriate value for the tax or subsidy. Even with full information, this solution may not lead to the optimal outcome. For instance, taxes can lead to excessive deterrence when overlapping remedies, such as litigation, benevolence, regulation, or risk burdens are in place (Viscusi 1991, p. 129). Furthermore, the application of taxes or subsidies can obscure preferable alternatives, such as options to move polluters or pollution victims to new locations when the benefit of such a move exceeds the cost.

The introduction noted Coase's (1960) finding that private bargaining can lead to efficient decisions in the face of externalities when property rights are clearly defined and transaction costs are insignificant. Anderson (2019) explains that Coasian solutions may fail in cases involving multiple victims, multiple sources, incomplete information, strategic behavior, time lags, asymmetric information, or social mores against such bargaining. Similarly, Anderlini and Felli (2006) show that common transaction costs can upset the efficiency of Coasian bargaining.

Hardin (1968) advocated private property rights to place the otherwise external costs of activities that degrade open-access land onto property owners. For similar reasons, Libecap (2009) advocates rights-based solutions such as tradable emissions permits, individual transferable quotas, and private water rights. However, all such market-based instruments rely on the ability to privatize and enforce rights to emissions or resources. It may be impossible to privatize resources such as flowing water or air. Ocean fisheries are among the resources that are difficult to monitor. And national forests are

among the natural resources that provide public goods, such as oxygen and carbon sequestration, the benefits of which are not internalized even if the forests become private.

Economists have long understood that votes can reveal valuable information and guide socially efficient decisions. [Wicksell \(1958\)](#) advocates votes to select both public expenditures and taxes that are optimal for society. [Musgrave \(1959\)](#) explains that externalities thwart the efficiency of markets and advocates voting mechanisms to reveal consumers' true preferences. In his discussion of regulations and taxes that impose burdens on other countries, [Piketty \(1996, p. 16\)](#) describes voting as a "natural way to induce individual agents to internalize an externality". The present article shares that objective, but uses a model unlike that of other authors to explain how the virtues of voting extend to social optimality in environmental policy decisions.

3. The Theoretical Model

The efficiency of environmental policy depends on the incentives that drive decision makers. Let ρ be the price of a product that consumers could buy to reduce their carbon footprint, such as supplemental home insulation, a windmill, an electric car, or bamboo flooring. Let α represent the discounted present value of the entirely private benefit from that purchase, such as the savings on utility bills achieved with added insulation or a windmill. Let β represent the discounted present value of the benefit to society of purchasing the product.

Assuming n citizens share the social benefit equally, each consumer's share of the social benefit is β/n . It is privately optimal to purchase the product if the consumer's benefit exceeds the price:

$$\alpha + \beta/n > \rho.$$

It is socially optimal to purchase the product if the benefit to society exceeds the price:

$$\alpha + \beta > \rho.$$

The private solution differs from the socially optimal solution, in that the consumer will not purchase the good even though it provides a net gain to society, if

$$\alpha + \beta > \rho > \alpha + \beta/n.$$

Inefficiency arises from the product's external benefit,

$$\beta - \beta/n.$$

Under conditions that include an absence of transaction costs, the citizens experiencing the negative externalities would be willing to offer consumers Coasian bribes of up to $\beta - \beta/n$ to purchase the product. However, if n is large, coordination and negotiation among the affected citizens create transaction costs that generally obstruct socially efficient outcomes.

Although a fully informed and benevolent government could offer a subsidy of $\beta - \beta/n$ for purchases of the good, government authorities may have poor estimates of β or be influenced by ulterior motives. Privatization is unlikely to lead to social efficiency because, as discussed in Section 2, the privatization of oceans, forests, and other resources affected by carbon emissions is often unrealistic or ineffective.

An alternative solution would be to hold a referendum in which each citizen would vote on whether everyone should be required to purchase the product. A simple majority would determine the outcome. Each citizen's decision on the purchase mandate hinges on a criterion that differs from the private purchase decision because the vote determines whether everyone purchases the product. A citizen's successful vote in favor of the mandate leads to a benefit to that citizen of the private savings

plus the share of the per-capita social benefit the citizen receives from each mandated purchase times the number of purchases:

$$\alpha + n(\beta/n) = \alpha + \beta.$$

Hence, the benefit of voting in favor of the mandate equals the social benefit of purchasing the good, and each citizen will vote in favor if and only if that benefit exceeds the product price: $\alpha + \beta > \rho$. In other words, citizens will make the socially optimal decision. Section 4 provides a numerical example.

The result holds even if the social benefit of purchasing the product differs across citizens. For example, suppose a purchase lowers some users' carbon footprint more than others'. That would be true in the case of electric cars if some car owners were replacing cars that polluted heavily and others were replacing cars with minimal emissions. Let B represent the discounted net present value of the benefits to society from a purchase by a citizen who creates high benefits, and b represent the discounted net present value of the benefits to society from a purchase by a citizen who creates low benefits. Let h be the number of citizens whose purchase creates high benefits, while a purchase by the remaining $n-h$ citizens creates low benefits. The criterion for a socially optimal outcome is that each citizen votes in favor of the mandate if and only if $\alpha + \bar{\beta} > \rho$, with $\bar{\beta}$ representing the mean social benefit from the product.

Whether a citizen's purchase creates high or low benefits, a successful vote in favor of the mandate gives each citizen

$$\alpha + (hB)/n + [(n-h)b]/n = \alpha + [hB + (n-h)b]/n = \alpha + \bar{\beta}.$$

Thus, whether their purchase creates high or low benefits, citizens will vote in favor of the mandate if and only if the criterion for social optimality is met: $\alpha + \bar{\beta} > \rho$.

Because each citizen will vote for the socially optimal outcome, a referendum yields the best decision for society regardless of how many citizens vote. It also does not matter whether the associated externalities are positive or negative. As an example of the latter, consider the decision of whether car owners should be required to have their exhaust systems checked annually for excessive emissions. In that case α and β represent the private and social benefits of eliminating the negative externality of emissions, and the model as shown above demonstrates that a vote leads to the socially optimal outcome.

The efficient voter rule rests on the assumption that citizens are informed about the price of the product, ρ , their entirely private benefit, α , and the equally shared social benefit they receive from each user, β/n . The socially efficient outcome is not assured if citizens lack information on their own costs or benefits. Hidden costs or benefits will similarly derail the social efficiency of Coasian bargaining and privatization. The Pigouvian approach of taxes or subsidies may be preferable if the government holds information on the associated externalities and the citizens do not know their own costs and benefits. If neither the citizens nor the government knows the relevant values, none of these approaches can assure the appropriate decision and the path to a socially efficient outcome begins with a pursuit of information. Prohibitive information costs send the question into a realm of decision making under uncertainty that is beyond the scope of this article.

4. Discussion

The efficient voter rule applies to a broad set of environmental exigencies. Consider a numerical example. With single-use plastics overwhelming waste systems around the world, economies must decide whether to ban plastic shopping bags. Suppose each citizen receives \$200 worth of convenience annually from the use of plastic shopping bags. Suppose also that each citizen who does not use plastic shopping bags creates two types of benefits: \$50 worth of personal pride or "warm glow" from helping the environment, and \$500 worth of avoided environmental damage, a benefit that is spread evenly among 1000 citizens.

In this scenario, it is not socially optimal to use plastic shopping bags because each citizen's \$200 value of convenience from using the bags is less than the \$550 worth of pride and damage-avoidance to be gained by giving them up. Even so, citizens would use the bags because their \$200 private benefit would exceed their \$50.50 opportunity cost of bag use—the sum of \$50 worth of forgone pride and $\$500/1000 = \0.50 in forgone environmental benefits. An externality problem arises because each citizen fails to internalize the \$499.50 worth of environmental benefits a decision against bags would confer on the 999 other citizens.

Given the opportunity to vote on an economy-wide plastic bag ban, the citizens know that their decision could affect everyone's behavior, not just their own. The citizens would each weigh their \$200 loss of convenience from the ban against their \$50 gain in pride plus their \$0.50 share of each of 1000 citizens' environmental benefits from the ban, for a total of $\$50 + 1000 \times \$0.50 = \$550$. Because $\$200 < \550 , citizens would vote in favor of the ban, and the vote would achieve the socially optimal outcome.

To examine a case in which the proposed policy is not socially efficient, consider an alternative scenario in which each citizen's annual convenience from using plastic shopping bags is worth \$600. In that case, each citizen's \$550 annual benefit from a ban falls short of the \$600 cost of lost convenience. Given the opportunity to vote, citizens would weigh their \$600 loss from a ban against their \$550 benefit, and they would vote against the ban. Again, the vote would achieve the socially optimal outcome.

The viability of a voting solution depends on the cost of a referendum. It may be possible to add referendum items to the ballot for a scheduled election at a negligible cost. In the event that a referendum would require a special election involving substantial costs, the added expense might be prohibitive and an alternative solution may be preferable. Other approaches face similar considerations. As discussed in Section 2, Coasian bargaining can involve prohibitive transaction costs. Likewise, Pigouvian taxes and subsidies impose implementation costs and deadweight loss. When several contemplated approaches involve associated costs, a comparison of those costs will inform the choice among those options.

Note that the workings of the efficient voter rule are not reliant on a well-informed government. Authorities do not need to estimate the value of citizens' pride from not using plastic shopping bags or the value of citizens' convenience from using the bags. The government only needs to call a referendum. The citizens only need to know how bag use would affect them personally, which is a combination of the value of their lost pride, their convenience, and their share of the cost of everyone's environmental damage.

Myriad environmental policy decisions are well suited for voting solutions. Examples include a community's decision whether to welcome a natural gas pipeline to run through its soil (Anderson 2020). In 2020, California governor Gavin Newsom signed an executive order banning electric cars by the year 2035 (Sommer and Neuman 2020). The controversial decision was not made using a vote. To the extent that citizens are able to purchase the most basic electric cars for approximately the same price (e.g., Tesla plans to make a model available to everyone for \$25,000 by 2025), and that citizens face similar repercussions from pollution and climate change, a vote on a requirement that every car be electric would lead to a socially optimal outcome. The same is true for votes on mandates for solar panels, limits on deforestation, taxes on carbon, and regulations on lawn chemicals.

Votes could lead to efficient decisions about participation in environmental agreements as well. The United States withdrew from the Paris Agreement on climate change, while a majority of Americans preferred participation (Marlon et al. 2017). If an agreement would place a similar burden on citizens in terms of its influence on lifestyle, taxes, and product prices, and the agreement would provide uniformly distributed benefits by preventing climate change and offering every citizen a viable living environment, the efficient voter rule applies. Making any such decision with a mechanism that brings citizens to internalize the repercussions of their behavior serves the goal of allocative efficiency and reveals interests of the citizenry that legislators may not fully comprehend.

Modern practice demonstrates the viability of voting to reach decisions about environmental issues. In 2020, U.S. voters addressed topics including the reintroduction of gray wolves in wilderness areas and requirements that electric utilities obtain half of their energy from renewable sources (Lohan 2020). Other examples include referendums on nuclear power in Japan, Germany, Italy, Switzerland, and Sweden (Obe 2012; Cyranoski 2001). The widespread use of voting to make environmental decisions indicates that the associated costs are manageable, and the efficient voter rule speaks to the desirability of the resulting outcomes.

Voting is not the best approach for every situation. Some decisions involve costs or benefits for voters that they do not understand despite ambitious informational campaigns. Policies with inordinate benefits, externalities or abatement costs for a subset of the population are better addressed by alternative processes. For example, if a minority of voters would experience substantially higher benefits or costs from a decision than the majority of voters, the outcome could be socially inefficient. The severity of environmental problems warrants attention to an assortment of remedies that are effective in varying circumstances. The applicability of the efficient voter rule to common dilemmas makes it a noteworthy addition to existing options.

5. Conclusions

The prevalence of life-threatening externality problems demonstrates the need for new means of incentivizing socially optimal decisions. A vote among fully informed parties on the provision of a uniformly distributed positive externality (or on the abolishment of a uniformly distributed negative externality) at a given cost per party will reveal the socially efficient outcome, regardless of the amount of the externality attributable to each party. This efficient voter rule extends to a wide array of environmental policy decisions whose benefits and costs are shared similarly by community members. Some groups already make such decisions by vote, and the efficient voter rule can assure policymakers of socially efficient outcomes. For the many issues currently addressed with laissez-faire or authoritarian approaches, the efficient voter rule indicates that referendums could shepherd environmental policy toward better service of society's needs.

Funding: This research received no external funding.

Conflicts of Interest: The author declares no conflict of interest.

References

- Anderlini, Luca, and Leonardo Felli. 2006. Transaction Costs and the Robustness of the Coase Theorem. *Economic Journal* 116: 223–45. [CrossRef]
- Anderson, David A. 2011. A Voting Approach to Externality Problems. *Journal of Economic & Social Policy* 14: 50–61.
- Anderson, David A. 2019. *Environmental Economics and Natural Resource Management*, 5th ed. New York: Routledge. [CrossRef]
- Anderson, David A. 2020. Natural Gas Transmission Pipelines: Risks and Remedies for Host Communities. *Energies* 13: 1873. [CrossRef]
- Buchanan, James M., and Gordon Tullock. 1962. *The Calculus of Consent: Logical Foundations of Constitutional Democracy*. Ann Arbor: University of Michigan Press. [CrossRef]
- Coase, Ronald H. 1960. The Problem of Social Cost. *Journal of Law and Economics* 3: 1–44. [CrossRef]
- Cyranoski, David. 2001. Referendum stalls Japanese nuclear power strategy. *Nature* 411: 729. [CrossRef] [PubMed]
- EPA. 2020. The Basics of the Regulatory Process. Available online: <https://www.epa.gov/laws-regulations/basics-regulatory-process> (accessed on 7 November 2020).
- Hardin, Garret. 1968. The Tragedy of the Commons. *Science* 162: 1243–48. [PubMed]
- Libecap, Gary D. 2009. The Tragedy of the Commons: Property Rights and Markets as Solutions to Resource and Environmental Problems. *Australian Journal of Agricultural and Resource Economics* 53: 129–44. [CrossRef]
- Lohan, Tara. 2020. Four Environmental Fights on the 2020 Ballot. Available online: <https://www.ecowatch.com/2020-environment-ballot-issues-2647868019.html> (accessed on 8 November 2020).

- Marlon, Jennifer, Eric Fine, and Anthony Leiserowitz. 2017. Majorities of Americans in Every State Support Participation in the Paris Agreement. Yale Program on Climate Change Communication. Available online: https://climatecommunication.yale.edu/publications/paris_agreement_by_state/ (accessed on 13 October 2020).
- Musgrave, Richard A. 1959. *The Theory of Public Finance: A Study in Public Economy*. New York: McGraw-Hill.
- Obe, Mitsuru. 2012. Fukushima Watch: Japan Mulls Referendum on Nuclear Power. *Wall Street Journal*. June 22. Available online: <https://www.wsj.com/articles/BL-JRTB-12323> (accessed on 8 November 2020).
- Pigou, Arthur C. 1932. *The Economics of Welfare*. London: Macmillan.
- Piketty, Thomas. 1996. A federal voting mechanism to solve the fiscal-externality problem. *European Economic Review* 40: 3–17. [CrossRef]
- Smith, Dylan. 2015. Red-Light Cameras Switched Off, Radar Vans Parked. *Tucson Sentinel*. November 5. Available online: http://www.tucsonsentinel.com/local/report/110515_red-light_cameras/red-light-cameras-switched-off-radar-vans-parked (accessed on 13 October 2020).
- Sommer, Lauren, and Scott Neuman. 2020. California Governor Signs Order Banning Sales of New Gasoline Cars by 2035: NPR. Available online: <https://www.npr.org/2020/09/23/916209659/california-governor-signs-order-banning-sales-of-new-gasoline-cars-by-2035> (accessed on 13 October 2020).
- Viscusi, W. Kip. 1991. *Reforming Products Liability*. Cambridge: Harvard University Press.
- Wicksell, K. 1958. A new principle of just taxation. In *Classics in the Theory of Public Finance*. Edited by Richard A. Musgrave and Alan T. Peacock. London: Palgrave Macmillan, ISBN 978-0-333-61355-9.
- Zhang, Xiaoling, and Yue Wang. 2017. How to reduce household carbon emissions: A review of experience and policy design considerations. *Energy Policy* 102: 116–24. [CrossRef]

Publisher's Note: MDPI stays neutral with regard to jurisdictional claims in published maps and institutional affiliations.



© 2020 by the author. Licensee MDPI, Basel, Switzerland. This article is an open access article distributed under the terms and conditions of the Creative Commons Attribution (CC BY) license (<http://creativecommons.org/licenses/by/4.0/>).

Article

Some Results on the Control of Polluting Firms According to Dynamic Nash and Stackelberg Patterns[†]

George E. Halkos * and George J. Papageorgiou

Laboratory of Operations Research, Department of Economics, University of Thessaly, 38333 Volos, Greece; gp.22594@gmail.com

* Correspondence: halkos@uth.gr

[†] This is an extended, updated and corrected version of Halkos and Papageorgiou (2014) discussion paper.

Abstract: In this paper we model the conflict between the group of polluting firms in a country and any social planner in the same country who attempts to control the volume of emissions generated during the production process. Both players of the game have their own control policies, i.e., the rate of emissions on behalf of the polluting firms and the rate of pollution control (e.g., pollution abatement or environmental taxation) on behalf of the home country. The common state variable of the model is the number of polluting firms, which aims to be minimized via the country's control policy, but on the polluters' side it is beneficial to be maximized. Regarding the game model, its setup belongs to the special class of differential games, which are called 'state separable differential games'. An important property of these games is that the open-loop Nash equilibrium coincides with the Markovian (closed-loop) equilibrium and, in the case of hierarchical moves, analytical solutions are easily obtained. The game proposed here is analyzed for both types of equilibrium, i.e., Nash and Stackelberg. In the simultaneous move game (i.e., the Nash game) we find the equilibrium's analytical expressions of the controls for both players, as well as the stationary value of the stock of polluting firms. A sensitivity analysis of the model's crucial variables takes place. In the hierarchical move game (i.e., the Stackelberg game) we find the equilibrium values of the controls, as well as of the state variable. As a result, a comparison between the two types of equilibrium for the game takes place. The analysis of the comparison reveals that the conflict is more intensive (since both controls have greater values) for the case in which the polluting firms act as the leader in the hierarchical move game.

Citation: Halkos, George E., and George J. Papageorgiou. 2021. Some Results on the Control of Polluting Firms According to Dynamic Nash and Stackelberg Patterns. *Economics* 9: 77. <https://doi.org/10.3390/economics9020077>

Academic Editor: Sajid Anwar

Received: 30 March 2021

Accepted: 10 May 2021

Published: 17 May 2021

Keywords: pollution control; environmental economics; differential games**JEL Classification:** C61; C62; D43; H21; Q50; Q52; Q53

Publisher's Note: MDPI stays neutral with regard to jurisdictional claims in published maps and institutional affiliations.



Copyright: © 2021 by the authors. Licensee MDPI, Basel, Switzerland. This article is an open access article distributed under the terms and conditions of the Creative Commons Attribution (CC BY) license (<https://creativecommons.org/licenses/by/4.0/>).

1. Introduction

Environmental pollution is an important topic and its management is particularly complex, since it has high requirements on governance, manpower and resources (Wang et al. 2011). Game theory has been proven to be an important tool regarding the investigation of issues of environmental pollution governance (Zhang et al. 2019). Game theory allows the analysis of different agents' strategies, while taking into consideration certain behavioral assumptions (Shi et al. 2016). More specifically, game theory can assist in investigating actions that individual decision makers can undertake in order to develop acceptable solutions, while providing valuable insights regarding planning, policy and design, something that traditional methods cannot offer (Madani 2010).

Game theory can be applied to climate change-related issues, providing a better understanding of the incentives, the barriers and the facilitation of cooperation in climate change mitigation. It has been found that the pollution produced by countries when they have a choice regarding how much to pollute is much more than the optimal measure,

based on the Nash equilibrium (Wood 2010). Game theory can also be applied to pollution control problems (Halkos 1996; Gromova et al. 2016; Wang et al. 2011).

For instance, Zhao and Jin (2021) constructed a game model regarding environmental pollution control between enterprises and local governments, while taking into consideration the constraint of the evaluation mechanism related to ecological values. The authors obtained a set of Nash equilibrium solutions as feedback and found that enterprises' pollution could be reduced by the influence of governmental ecological ethos, as well as by efforts for environmental protection. In addition, according to the authors, pollution management can be improved if the production cost of an enterprise can be reduced, alongside a reduction in pollution and severe punishment for wrong-doing.

In addition, game theory can be used to investigate the relationship between the behavior of a government and the strategies that supply chain enterprises follow, when it comes to the reduction of carbon emissions. More specifically, Chen and Hu (2018) develop an evolutionary game theory model, regarding the interactions between manufacturers and governments, investigating the effect that governments can have on the behavior of manufacturers, as well as examining whether carbon tax and subsidy mechanisms used by government will lead to low-carbon manufacturing. The authors conclude that a dynamic tax and dynamic subsidy mechanism can lead to the adoption of low-carbon manufacturing, while a static tax and subsidy mechanism is not effective and does not have the necessary positive impact on low-carbon production.

National policies on pollution can be modeled and investigated using a game theoretical approach. Schüller et al. (2017) focused on the interactions between EU countries and their choices regarding green policy investments, presenting different theoretical models: a Nash game, where the investment is made based on minimal expected costs, and two imitation approaches, in which a country imitates the investments of its neighbors, either taking into consideration, or not, its neighbors' costs or profits. The authors conclude that a reduction in pollution stock can be achieved, due to external forces increasing pollution costs. In addition, incentives can be found that will make a country friendlier to the environment.

Differential game models can be used in order to effectively design conflicting situations that exist between polluters and pollution victims. For instance, Halkos and Papageorgiou (2014) set up such a differential game model that involves a country's polluting firms and its social planning, and identified the analytical expressions regarding players' control and the state of the stock variable, i.e., the volume of the polluting firms. In addition, after the transformation of the Nash game into a Stackelberg game, the authors found that the conflict becomes more intense in the Stackelberg game, in which playing as leader is preferred.

The choice of differential game models, in order to efficiently design conflicting situations between polluters and the victims of pollution, is the rule rather than the exception. In this paper, we use the efficiency of differential game models to study the dynamic interactions between the polluting firms in a country and social planning mechanisms in the same country. The strength of the polluting firms as a group changes over time and is measured by the unified volume of active polluters, the transactions made among them, how dangerous to environmental amenities the polluting firms are as a unified group, and so on. New polluting firms are initiated and encouraged by the existing firms. Regarding polluter's attrition, their decay rate is affected by their own actions and by the counter-pollution actions of the home country. The essential targets of the home country are to derive utility from the polluting firms' emissions reduction, but the home country faces substantial costs in combating the polluters and suffers from disutility stemming from the size of the polluters. Conversely, each polluting firm wants to maximize the size of the group of polluters, as well as the utility stemming from emissions. The argument that each polluting firm wants to maximize the size of the group seems somewhat extraordinary. In the next paragraph, we will try to shed some light on this intuition.

The model we deal with in this paper is based on the description of the evolution over time of polluting firms considered as a stock. A major distinction from other models is that there are two decision makers, whereas in former models there is only one, i.e., the social planner. Furthermore, here we consider the strategic interaction of the two decision makers with conflicting interests. Therefore, it is convenient to refer to the decision maker on the polluting firms' side as "the Polluting Organization (PO)". On the other side, the opponent of the polluting organization is assumed to be the government of the country in which the polluting activities take place. Both PO and the target country have (at least) one strategic weapon in order to alter the status quo. The PO can choose the rate of emissions and the target country can choose the rate of the measures used against polluting emissions. In other words, we speak of the strong conflict between the social planner (the government) on the one hand and the polluting firms as an organization on the other. Therefore, it is plausible to conclude that the larger the number of polluting firms, the more powerful the polluting organization (PO). Obviously, the economic benefits for each polluting firm stemming from a higher level of pollution (as a part of overall emissions with lower abatement levels) are higher.

In this study we deal with a special class of differential games called state-separable games. State-separable differential games belong to the special class of dynamic games which allow, in most cases, derivation of the Nash solutions in explicit form. The advantage in obtaining analytical solutions, according to Dockner et al. (2000), is of great importance, because the derived mathematical expressions of the solutions are crucial for the study of the qualitative properties of equilibrium.

Due to the simplicity of the structure, state separable differential games are characterized by the linearity of the objective functional with respect to the state variable(s) and by no interaction between control and state variables (Dockner et al. 1985). An important property of state separable games is related to the information structure employed. The importance of this property is that the open loop Nash solution coincides with the closed loop (Markovian) Nash solution.

Another important property hinges on the way the game is played, i.e., simultaneously (Nash) or hierarchically (Stackelberg). As is known (e.g., Başar and Olsder 1999; Dockner et al. 2000), in the Stackelberg games, the adjoint variable of the leader with respect to the adjoint variable of the follower plays a crucial role in the solution process, but due to state separability the interconnection between these variables vanishes.

In the rest of the paper, we determine the Nash and the Stackelberg solutions of the environmental differential game and the state-separability advantage allows us to note some useful propositions and to carry out a sensitivity analysis. Regarding the design efficient counter-pollution actions against the polluting firms of a country, the model parameters of the game and the relevance of the two solutions offer useful information.

The paper is organized as follows. In Section 2, we set up the basic model. Section 3 considers the solutions of the Nash equilibrium and performs a simple sensitivity analysis. In Section 4, we compute the analytical expressions of the Stackelberg equilibrium, while the polluting firms lead and the social planner of home country follows. Section 5 compares the two solution strategies, while the last section concludes the paper.

2. The Model

In the real world scenario, it seems plausible that the mere existence of polluting firms (POs) is considered as an intertemporal threat to any home country's environmental quality. Translated into conflicting strategies, the polluting firms, on the one hand, have to decide about the volume of the emissions they will carry out, while the home country on the other hand has to act defensively in the "war on pollution". In the model presented here the state variable of the above clash is the volume of polluting firms (the size of PO), which is denoted by x .

Moreover, the group of polluting firms (the size of PO) does not remain at the same volume, but without any government intervention new polluters which are supported

by the existing firms are added, because it is profitable for the firms to pollute since this reduces their operating costs during the production process. Therefore, it is reasonable to face the growth of polluting firms (the growth of PO size), as in the population models, in the absence of controls. As in biological population models, a simple equation suitable to describe the evolution of the number of polluting firms at time t , (t) , is the following differential

$$\dot{x} = gx \Leftrightarrow x = e^{gx}, \quad x(0) > 0 \quad (1)$$

where $g > 0$ denotes the endogenous growth rate of the polluting firms (of the PO).

From now on, we deal with the possible controls that can be introduced in Equation (1). First of all, the volume of emission realizations (hence denoted by v) reduces the number of polluting firms due to the compliance costs, i.e., the more (the stronger) the emissions the higher the penalties imposed by authorities, therefore the lower the number of the polluting firms that survive due to these costs. We assume for simplicity that this fact is proportional to the number of emission realizations, i.e., γv , and as the volume of the polluters reduces, it is added as an outflow term to Equation (1), i.e., it is entered into (1) with the minus sign.

Moreover, we set the intensity u of the counter-emissions effort as the control variable of the home country. The greater the intensity of the counter-emissions effort, the more resources devoted to investigating the implications of emission realization. Moreover, the stronger the home country's counter-pollution effort, the more effective the reduction of the polluting firms. We assume that this fact is the linear term $f(u) = \beta u$, and the parameter β denotes the percentage losses per emission realization, on behalf the polluting firms, when the social planner of the country, abates (or taxes) the pollutants (a policy which often called counter-offensive). Since the above term, $f(u) = \beta u$, reduces the volume of the polluting firms, we add as the second outflow term to (1), weighted by the volume of emissions v with the weight βu , i.e., the outflow term is βuv .

Regarding the control variable of the home country, i.e., the intensity of counter-pollution effort, this control certainly reduces the number of the polluting firms and therefore a new negative term is entered into Equation (1). This term represents the losses due to the intensity of counter-measures at the initiation phase and is proportional to the control u , i.e., is the term ϕu . It is worth noting that taking measures against the polluting firms' initiation is a very sensitive process as the planner of the home country has to discriminate among the firms. Since the discrimination processes lurking risks (e.g., the environmental taxation must be fair for all the people), we designate this inflow to Equation (1), as a quadratic cost function of the intensity of pollution control measures (i.e., it is based on the square of abatement or taxation).

After all, the volume of polluting firms, i.e., the size of PO, evolves according to the following equation:

$$\frac{dx}{dt} = \dot{x} = gx - \phi u + \frac{a}{2}u^2 - \gamma v - \beta uv$$

where:

$x \geq 0$ the state variable (the number of polluting firms or the size of PO)

$u \geq 0$ the control variable of the home country, i.e., the intensity of the home country's counter pollution effort;

$v \geq 0$ emissions' rate (control variable of the polluting firms acting as organization);

$g \geq 0$ endogenous growth rate of the group of polluters (of PO);

$\phi \geq 0$ the rate at which the counter pollution measures would reduces the size of PO;

$\frac{a}{2} \geq 0$ the cost factor which faces the home country due to the unsuccessful discrimination among the overall firms during the abatement (or taxation);

$\beta \geq 0$ percentage losses of the polluters per emission;

$\gamma \geq 0$ average number of polluting firms which are not able to face the compliance costs.

Regarding the players' payoffs, we assume in this paper that the social planner of the home country wishes to minimize the following objectives. First, they want to minimize

the volume of emissions v and second to minimize the number of the polluting firms x , i.e., the size of PO (which is the state variable of the model). An important reason for which the social planner may wish to minimize the volume of polluting firms (or the size of PO) is because the threat of pollutants concentration is costly for the home country. These costs are in association with the uncertainty of business investments and in turn lead to market shrinkage. As the third objective, the home country has an interest in minimizing the counter-pollution effort (e.g., in lowering the environmental tax factor), by minimizing its control variable u . It is well known that the pollution-control activities cost money, as almost any control policy exertion. In the decision making literature, the social planning, in intertemporal formulations, is described as trying to minimize a weighted sum of the state x and the opponent's control v , as well as the effort cost stemming from its own control variable u . Therefore, after the above simplified assumptions and with a positive discount rate ρ_1 , the intertemporal minimized functional of the social planner will be the following

$$\min_{u(\cdot)} \int_0^{\infty} e^{-\rho_1 t} (c_1 x + c_2 v + c_3 u) dt \tag{2}$$

The polluting firms as a group, i.e., the PO, on the other hand, are interested to increasing their number x in order to exert more market power. The emissions' rate v is their control variable which is maximized. However, the emission realizations cost money and this cost is represented in the objective functional by the quadratic cost function $(c_4/2)v^2$. Regarding the polluting firms benefits with respect to the counter pollution effort, i.e., the home country's control variable u , the high values of that control may work as an indirect way of stirring up sentiments against the home government's environmental policy. Therefore, we represent this displeasure as a polluting firms' benefit (as PO benefits) and we set in their objective functional as the weighted term b_u .

Therefore, for a positive discount rate ρ_2 the intertemporal objective function of the representative polluting firm may be the following

$$\max_{v(\cdot)} \int_0^{\infty} e^{-\rho_2 t} \left(b_1 x + b_2 v + b_3 u - \frac{c_4}{2} v^2 \right) dt \tag{3}$$

$$\text{with } \rho_i > g \quad i = 1, 2 \tag{4}$$

Hereafter and in the games that follow, the home country minimizes functional (2) and the polluting firms, i.e., the PO, maximizes (3) subject to (1) and the path constraints

$$x, u, v \geq 0$$

In the next sections, we proceed with the calculation of both Nash and Stackelberg equilibrium solutions.

3. Nash Equilibrium

The Nash equilibrium computation is derived under the assumption that both players play the game at the same time. Then, every player of the game (i.e., the home country and the polluting firms) has to solve their own optimal control problem, taking the opponent's reaction as given. Finally, the two optimal control solutions determine the game optimal strategies u^* , v^* . In the following, we denote by λ and μ the shadow prices of the state variable x for the country and the polluting firms, respectively. Now, the current value Hamiltonians of the game described above are given by

$$H_1 = -c_1 x - c_2 v - c_3 u + \lambda \left(g x - \phi u + \frac{a}{2} u^2 - \gamma v - \beta u v \right) \tag{5}$$

$$H_2 = b_1 x + \left(b_2 - \frac{c_4}{2} v \right) v + b_3 u + \mu \left(g x - \phi u + \frac{a}{2} u^2 - \gamma v - \beta u v \right) \tag{6}$$

Proposition 1. *Along the optimal path, the shadow price λ of the state variable x for the country is always negative, since one additional polluting firm is always harmful for the environmental quality of the country. Conversely the shadow price μ of the volume of the polluting firms x (of the size of PO) for the PO, is positive along the optimal path, because one more polluting firm added to the PO, increases the benefits of the overall polluting.*

Proof. The result is obtained through Pontryagin’s maximum principle optimality conditions, i.e.,

$$\dot{\lambda} = (\rho_1 - g)\lambda + c_1 \tag{7}$$

$$\text{with the equilibrium } \dot{\lambda} = 0 \Rightarrow \hat{\lambda} = -\frac{c_1}{\rho_1 - g} < 0 \tag{8a}$$

and the shadow price of the polluting firms evolves according to the following equation

$$\dot{\mu} = (\rho_2 - g)\mu - b_1 \tag{8b}$$

$$\text{with equilibrium } \hat{\mu} = \frac{b_1}{\rho_2 - g} > 0$$

According to (8a), the long-run damage associated for the country increases as one more polluting firm is added to the volume of polluting firms (PO) (i.e., as λ increases). This is the result of an increasing cost associated with the existence of a polluting firm (i.e., the factor c_1 in the home country’s objective functional). The latter obvious conclusion is a prediction of the setup correctness for our model. Note that according to basic theorems of the optimal control theory, the transversality conditions hold for all admissible state trajectories (see, e.g., Grass et al. 2008). □

For the following analysis presented here, it is assumed that only interior solutions exist and they are positive, i.e., (10). According to Pontryagin’s maximum principle, the maximizing condition of the Hamiltonian for the intensity of the home country’s pollution-control effort (the home country’s control variable) is given by

$$\begin{aligned} \frac{\partial H_1}{\partial u} = 0 &\Leftrightarrow -c_3 + \lambda\phi - \lambda\beta v + \lambda au = 0 \Leftrightarrow \\ u^* &= \frac{1}{a} \left(\frac{c_3}{\lambda} + \gamma + \beta v \right) \end{aligned} \tag{9}$$

The result (9) is recorded in Proposition 2.

Proposition 2. *The optimal strategy of counter-pollution effort u^* increases with:*

- (a) *A rising volume of emissions;*
- (b) *An increasing percentage lost of polluting firms (PO) per emissions;*
- (c) *An increasing rate at which pollution-control reduce the polluting firms (PO) (γ)*

The cost factor which faces the home country due to the unsuccessful discrimination among the firms of the country during the exercise of the counter pollution measures ($a/2$) has a decreasing influence on the home country’s intensity of conducting the above effort.

Inspecting the analytical expression (9) of the control variable, it is worth noting that if the cost of control (c_3) is large relative to the shadow price λ (which is negative along the optimal path), the country’s optimal strategy u^* is to a low value and possibly meets the boundary at $u^* = 0$. Conversely, if the cost of the control is negligible with respect to the shadow price λ , the country’s optimal strategy is a linear function of emissions v , since the term c_3/λ in condition (9) vanishes. Therefore, it is optimal, in the former case, for the country to not exert any counter-pollution control.

Turning in the polluting firms (PO) problem, we take the Hamiltonian maximizing condition that is determined by

$$\frac{\partial H_2}{\partial v} = 0 \Leftrightarrow b_2 - c_4 v - \mu(\gamma - \beta v) = 0 \Leftrightarrow v^* = \frac{b_2}{c_4} - \frac{\mu}{c_4}(\gamma + \beta u) \tag{10}$$

We record the result (10), as

Proposition 3. *The optimal rate of the polluting firms' (of the PO) emissions v^* decreases with:*

- (a) *An increasing average number of the polluting firms abandonment (γ)*
- (b) *An increasing percentage losses per emission (βu)*
- (c) *An increasing value of the shadow price u (the shadow price of the polluting firms (PO)).*

According to (10) if the shadow price of the polluting firms is raised, then it is optimal for the polluting firms (the PO) to curb their emissions' rate. Conversely, along the polluters' optimal path, the rate of emissions increases as the benefits (b_2) accrued by the emissions increase relative to the costs c_4 .

The following is a useful corollary according to the optimality conditions (9) and (10): "Along the home country's optimal path the intensity of pollution-control measures raises while the rate of emissions increases, and the rate of emissions declines while the intensity of the counter-pollution measures is increasing".

As the next step, we explicitly calculate the stationary values of the crucial variables of the game.

Proposition 4.

- i. *The stationary values of the strategies in Nash equilibrium are the following:*

$$\begin{aligned} \hat{u}_N &= \frac{\beta(b_2 - \hat{\mu}\gamma) + c_4(\phi + c_3/\hat{\lambda})}{c_4 a + \hat{\mu}\beta^2} \\ \hat{v}_N &= \frac{a(b_2 - \hat{\mu}\gamma) - \hat{\mu}\beta(\phi + c_3/\hat{\lambda})}{c_4 a + \hat{\mu}\beta^2} \end{aligned} \tag{11}$$

α are given by (8a) and (8b), while the subscript N in (11) means the Nash solution.

- ii. *the Nash equilibrium value for the number of polluting firms is given by*

$$\hat{x}_N = \frac{1}{g} \left[\left(\phi - \frac{a}{2} \hat{u}_N \right) \hat{u}_N + (\gamma + \beta \hat{u}_N) \hat{v}_N \right] \tag{12}$$

b_2 as in (11).

Proof. In the Appendix A. \square

Here, it is worth noting that, thanks to the structure of the state-separable games, we have the competitive advantage in finding the analytical expressions of the controls as well as the expression of the state variable. Solution (11) is a unique closed loop Nash equilibrium. This advantage is rather unusual, since multiple equilibrium solutions in differential games are the most common. Due analytical expressions (11) and (12), it is easy to proceed with sensitivity analysis with respect to the model parameters.

Table 1 represents the results of sensitivity analysis. Taking the partial derivatives \hat{v}_N , the symbol "+" means that the partial derivative is greater than zero, the symbol "-" means the opposite case, 0 indicates that the result of the partial derivative is zero (the parameter is not a part of the control), and "?" denotes that the result is unknown. The results in Table 1 make some economic sense. Taking into account (8b), shadow price $\hat{\mu}$ for the polluting firms decreases with the discount factor ρ_2 , but increases with the factor b_1 and at the endogenous growth rate g . Taking into account (11), the stationary value of the

polluting firms \hat{x}_N decreases with increasing endogenous rate g (as the control factor c_3 equals to zero).

Table 1. A summary of the sensitivity analysis results.

	ϕ	α	β	γ	c_1	c_2	b_1	b_2	c_4	ρ_1	ρ_2
\hat{u}_N	+	−	?	−	0	0	0	+	0	0	0
\hat{v}_N	−	?	?	0	0	0	0	+	+	0	0
\hat{x}_N	+	−	+	+	0	0	0	0	0	0	0

4. The Leader–Follower Game (Polluting Firms (the PO) as a Leader)

In the Nash equilibrium solution, as illustrated above, it is assumed that the two player game played simultaneously, i.e., the moves of the rivals are made at the same time. As it is mentioned above, in this paper we explore and the other class of games in which one player, the leader, moves first, and the opponent, the follower, makes his/her decision at the second time. This hierarchical or sequential mode of playing is known as the leader–follower or Stackelberg model. In the game theory literature, e.g., [Başar and Olsder \(1999\)](#), at least one stepwise procedure to derive the equilibrium solution has been developed. In order to describe (for completeness) the solution procedure, we assume, without any loss of generality, the first player (the polluting firms (the PO)) is the leader and the second (the social planner of the country) is the follower. The control and the adjoint variables of the leader are denoted with $H_2 = b_1x + (b_2 - \frac{c_4}{2}v)v + b_3u^*(v) + \mu\dot{x} + \psi\dot{\lambda}$, respectively, and with (16) we denote the same variables for the follower. Moreover, for simplicity we assume in the analysis that follows that the cost of pollution control vanishes, i.e., $c_3 = 0$.

The three step procedure for the open-loop Stackelberg solution (e.g., [Grass et al. 2008](#); [Dockner et al. 2000](#); [Başar and Olsder 1999](#)) is as follows:

Step 1: The polluting firms, as group (i.e., the PO), announce their common strategy, v .

Step 2: For the given strategy v , the social planner of country (the follower) solves the same Nash optimal control problem. As it is mentioned in the Nash case (see (9)), the home’s optimal response to the strategy v of the polluting firms (the PO), will be

$$u^* = u^*(v) = \frac{1}{a}(\gamma + \beta v) \tag{13}$$

since it is assumed that $c_3 = 0$, and the shadow price λ for the follower is given by Equation (7).

Step 3: Now, in the last step, the leader has to solve the same as in the Nash case optimal control problem, but for the known reaction function (13) of the follower:

$$\max_{v(\cdot)} \int_0^\infty e^{-\rho_2 t} \left(b_1x + \left(b_2 - \frac{c_4}{2}v \right) v + b_3u^*(v) \right) dt$$

subject to the following two equations

$$\dot{x} = gx - \left(\phi - \frac{a}{2}u^*(v) \right) u^*(v) - \gamma v - \beta u^*(v)v \tag{14}$$

$$\dot{\lambda} = (\rho_1 - g)\lambda + c_1 \tag{15}$$

with $u^*(v)$ given by (13).

The Hamiltonian of player 2 (the follower) becomes

$$H_2 = b_1x + \left(b_2 - \frac{c_4}{2}v \right) v + b_3u^*(v) + \mu\dot{x} + \psi\dot{\lambda} \tag{16}$$

The adjoint variables are the shadow values of the states Δ for which the equations of motion are given by (14) and (15), respectively. Taking the first order condition for the Hamiltonian (16), i.e., $\partial H_2/\partial v = 0$ we found the optimal strategy v^* . The calculations of the stationary strategies are made through the substitutions in (13) the player's 2 optimal strategy. Then, the final expressions are given below as (17) and (18) and their associated propositions.

Proposition 5.

i. The optimal strategies for the social planner and the polluting firms (the PO) of the hierarchical game are given, respectively by the following expressions

$$\begin{aligned} \hat{u}_S &= \frac{\beta(b_2 - \hat{\mu}\gamma) + c_4\phi + b_3(\beta^2/a)}{c_4a + \hat{\mu}\beta^2} \\ \hat{v}_S &= \frac{a(b_2 - \hat{\mu}\gamma) - \beta(\hat{\mu}\phi - b_3)}{c_4a + \hat{\mu}\beta^2} \end{aligned} \tag{17}$$

ii. The number of polluting firms (the size of PO) is given by the expression

$$\hat{x}_S = \frac{1}{g} \left(\left(\phi - \frac{a}{2}\hat{u}_S \right) \hat{u}_S + (\gamma + \beta\hat{u}_S)\hat{v}_S \right) \tag{18}$$

and the optimal controls are given by (17), with the subscript S to denote the Stackelberg strategy.

Proof. In the Appendix A. \square

Since the analytical expressions of the optimal strategies are computed for both types of the game, in the next section we compare these values. The reverse case at which the country moves first as a leader and the polluting firms follow is not examined here and is left for future research.

5. Comparison of the Two Solutions

Taking the Nash solutions (11) and the Stackelberg solutions (17) the optimal controls can be expressed as

$$\begin{aligned} \hat{u}_S &= \hat{u}_N + \frac{\beta}{a}\Delta \\ \hat{v}_S &= \hat{v}_N + \Delta \end{aligned}$$

while

$$\Delta = \frac{b_3\beta}{c_4a + \beta^2\hat{\mu}} > 0 \tag{19}$$

the difference between the optimal stationary strategies is given by (19). Some remarks can be drawn about the difference of the two solutions of the same game. These observations could be:

- (i) The fewer the polluting firm's losses per emission (β), the smaller the difference Δ . If the loss rate β vanishes ($\beta = 0$), the Nash and Stackelberg equilibrium solutions become equal.
- (ii) If the polluting firms have no objective related to the unsuccessful discrimination of the social planner ($b_3 = 0$), the Nash and Stackelberg equilibrium solutions are equal. If the same factor b_3 is positive, the group of polluting firms (the PO) announces a volume of emissions, v_S , such that the home country reacts with a higher counter-pollution effort, v_S . As a result, the number of polluting firms (the size of the PO), x , increases which, in turn, increases the volume of emissions. As follows from the comparison of (11) and (17),

$$\hat{u}_S > \hat{u}_N \text{ and } \hat{v}_S > \hat{v}_N$$

This means that the conflict will be more intense if the group of polluting firms has the first mover advantage and announces the volume of emissions to be carried out (compared to the simultaneous move game). Consequently, the next result became obvious.

Proposition 6. *The pollution control hierarchical game in which the group of polluting firms (the PO) being the leader and the country the follower, results in a higher volume of emissions and in a more intensive counter-pollution effort, i.e., the conflict between the players is more intensive.*

The difference between the equilibrium values (12) and (18) is positive, that is $D = \hat{x}_S - \hat{x}_N > 0$, and therefore we can conclude that for the polluting firms (the PO), being the leader is verified as the better position due to the increase in the size of D.

Linear state Equations (12) and (18) can explicitly solved with respect to the size of the PO which is the state variable $x(t)$, yielding:

$$x_N(t) = x_{N0}e^{\delta t} + \hat{x}_N(1 - e^{\delta t})$$

$$x_S(t) = x_{S0}e^{\delta t} + \hat{x}_S(1 - e^{\delta t})$$

Additionally, the value functions for the Nash and Stackelberg equilibrium is easy computed as:

$$V_{2,N} = \int_0^{\infty} e^{-\rho_2 t} (b_1 x + b_2 \hat{v}_N + b_3 \hat{u}_N - \frac{c_4}{2} \hat{v}_N^2) dt =$$

$$= b_1 \frac{\rho_2 x_{N0} - g \hat{x}_N}{\rho_2(\rho_2 - g)} + \frac{2b_2 \hat{v}_N - c_4 \hat{v}_N^2 + 2b_3 \hat{u}_N}{2\rho_2}$$

and

$$V_{2,S} = \int_0^{\infty} e^{-\rho_2 t} (b_1 x + b_2 \hat{v}_S + b_3 \hat{u}_N - \frac{c_4}{2} \hat{v}_S^2) dt =$$

$$= b_1 \frac{\rho_2 x_{S0} - g \hat{x}_S}{\rho_2(\rho_2 - g)} + \frac{2b_2 \hat{v}_S - c_4 \hat{v}_S^2 + 2b_3 \hat{u}_S}{2\rho_2}$$

Moreover, the difference of the two value functions

$$V_{2,S} - V_{2,N} = \frac{b_3 \beta \Delta}{2\rho_2 a} > 0$$

is positive, and therefore becomes better for the group of the polluting firms to lead playing the Stackelberg strategy than playing the Nash strategy. This result is recorded as Proposition 7.

Proposition 7. *In the environmental pollution game between the polluting firms of a country and the social planner of the same country the more beneficial strategy, on the polluters side, is the strategy in which they lead (and the home country follows) in a Stackelberg setting.*

6. Conclusions

In this paper, we set up a differential game model between the polluting firms of a country and the social planner of the same country. The model belongs to the special tractable class of state-separable games. This class of games has a special feature in the Nash equilibrium, for which the open-loop equilibrium coincides with the closed-loop (Markovian) equilibrium. During the solution process of the simultaneous move game (the Nash case), we found the analytical expressions of both players' are controlled as well as the steady state of the stock variable (which is the volume of the polluting firms). Sensitivity analysis, which is an analysis between the controls and crucial variables of the model, makes economic sense.

Some results, based on the proved propositions discussed in the main text, are as follows. First of all, in the simultaneous move game, the first proposition, which operates as a verification of the correctness of our model, states that the marginal increment of the size of the polluting group (one more polluting firm added to the entire stock) is always

harmful for the environmental quality of the country. The measure of this damage is indicated by the negative value of the shadow price of the size of polluting firms, but from the side of the country's social planner. It is worth noting that the measure of the shadow price (expressed by the adjoint or costate variable of the state variable) is the more common and a most accurate measure in the technique of game theory.

Conversely, the same result, but from the polluting firms' side, says that a marginal increment of the size of the group of polluting firms increases their benefits. Again, as game theory dictates, we work with the shadow prices, but from the side of the polluting firms. The second result considers the conditions under which any counter pollution strategy on behalf of the social planner would be optimal. The proved results of our model are based on the variables of the proposed model. More specifically, a counter-pollution strategy is optimal if this strategy increases with a rising volume of emissions, with increasing percentage loss of polluting firms and with increased effectiveness of pollution control on behalf of the social planner of the country. The third result tackles the polluting firms, as a group, regarding their strategy.

As a policy implication, on the polluting firms' side, the group of the polluting firms could have in mind that their optimal strategy decreases with the number of polluting firms' abandonment rate, with increasing losses per emission and in the case at which the shadow price of the of the social planner of the country (which measures the size of the polluting firms) increases. The latter case, i.e., the shadow price of the social planner increases, states the beneficial nature of the situation (which is therefore harmful for the polluting firms as a group). The fourth result is very technical and gives precise computed expressions of strategies for both players. It is worth noting that the equilibrium value (for the simultaneous move game) of the number of polluting firms depends on the reversing of intrinsic growth rate g , but also depends on the equilibrium strategies of both players (\hat{u}_N, \hat{v}_N) , showing that the evolution of the size of the polluting firms, i.e., the state variable \hat{x}_N , is time-consistent with a more demanding property, which also means that the state variable is not only a function of time.

In the dynamic hierarchical setting section, in order to compare the simultaneous move game and the hierarchical game values, we compute the exact values of the Stackelberg game. This result is recorded in Proposition 5. The comparison of the two results of the different equilibrium patterns strategies shows that the Stackelberg strategies are superior to the Nash strategies, showing again that the model and its parameters obey the economic theory. With this model, we conclude that the difference between the strategies becomes smaller (i.e., the Nash equilibrium strategies approaches the Stackelberg) as the losses per emission on behalf of the polluting firms decreases. A major result drawing from this hierarchical setting is that the conflict between the players of the game is more intense in this case than in the Nash case, and the first-mover advantage is still present since it is proved that the size of the polluting firms is greater in the Stackelberg case, in which the polluting firms lead. Similarly, computing the payoffs for both players, it is proved by the proposed model that is more beneficial for the polluting firms to play the hierarchical game, in which they lead.

Finally, let us mention that one major limitation of the proposed model is that, considering the polluting firms acting as a group, there is no room for further conclusions and policy implications about the behaviour of the polluting firms involved in a group. This is a drawback of the proposed model which is under consideration for future improvement. Another limitation is that the model is restricted, in the Stackelberg setting, only in one case, at which the polluting firms as a group announce their policy (i.e., the volume of the pollutants that they would emit), and therefore they are set as the leader of the hierarchical game. Undoubtedly there is the opposite case in which the policy maker of the country, announcing its policy first, could be the leader of the same hierarchical game. This case would be the second extension of our primary model in the future research.

Author Contributions: G.E.H. and G.J.P. contributed equally. All authors have read and agreed to the published version of the manuscript.

Funding: This research received no external funding.

Institutional Review Board Statement: Not applicable.

Data Availability Statement: Not applicable.

Acknowledgments: Thanks are due to the Editor and the anonymous reviewers for their helpful and constructive comments. Any remaining errors are solely the authors' responsibility.

Conflicts of Interest: The authors declare no conflict of interest.

Appendix A

Proof of Proposition 4. The Hamiltonian of the country's social planner is given by (5) in the main text as the following

$$H_1 = -c_1x - c_2v - c_3u + \lambda \left(gx - \phi u + \frac{a}{2}u^2 - \gamma v - \beta uv \right)$$

and the first order condition $\partial H_2 / \partial v = 0$, becomes $-c_3 + \lambda(-\phi + au - \beta v) = 0$.

Substituting the optimal value of the opponent's control v^* given by (10) in the main text, i.e., $v^* = b_2/c_4 - \mu(\gamma + \beta u)/c_4$ the first order condition yields:

$$\partial H_1 / \partial u = -c_3 + \lambda(-\phi + au - \beta(b_2/c_4 - \mu(\gamma + \beta u)/c_4)) = 0$$

from which the optimal Nash strategy for the social planner \hat{u}_N , is as follows

$$\hat{u}_N = \frac{c_4(\phi + c_3/\hat{\lambda}) + \beta(b_2 - \hat{\mu}\gamma)}{c_4a + \hat{\mu}\beta^2}$$

Making the same steps as for the social planner's Nash strategy, but with the polluter's Hamiltonian, we have from (6) and (9) in the main text

$$\begin{aligned} H_2 &= b_1x + (b_2 - \frac{c_4}{2}v)v + b_3u + \mu(gx - \phi u + \frac{a}{2}u^2 - \gamma v - \beta uv) \Leftrightarrow \\ \partial H_2 / \partial v &= -c_4v + b_2 + \mu(-\gamma - \beta u) = 0 \stackrel{(9)}{\Leftrightarrow} \\ -c_4v + b_2 + \mu\left(-\gamma - \beta \frac{1}{a}\left(\frac{c_3}{\hat{\lambda}} + \gamma + \beta v\right)\right) &= 0 \Leftrightarrow \end{aligned}$$

$$\hat{v}_N = \frac{a(b_2 - \hat{\mu}\gamma) - \hat{\mu}\beta\left(\frac{c_3}{\hat{\lambda}} + \gamma\right)}{c_4a + \hat{\mu}\beta^2}$$

the result $\hat{x}_N = \frac{1}{g}[(\phi - \frac{a}{2}\hat{u}_N)\hat{u}_N + (\gamma + \beta\hat{u}_N)\hat{v}_N]$ is easily obtained, solving the differential equation $\dot{x} = gx - \phi u + \frac{a}{2}u^2 - \gamma v - \beta uv$ and setting zero the integration constant. \square

Proof of Proposition 5. The Hamiltonian of the polluting firms is given by (16) in the main text and is

$$H_2 = b_1x + \left(b_2 - \frac{c_4}{2}v\right)v + b_3u^*(v) + \mu\dot{x} + \psi\dot{\lambda}$$

while the time differentials $\dot{x}, \dot{\lambda}$ are given by (14) and (15) as

$$\dot{x} = gx - \left(\phi - \frac{a}{2}u^*(v)\right)u^*(v) - \gamma v - \beta u^*(v)v$$

$$\dot{\lambda} = (\rho_1 - g)\lambda + c_1$$

substituting the values of the adjoint variables back into the follower's Hamiltonian this function becomes (after some algebraic manipulations)

$$H_2 = b_1x + \left(b_2 - \frac{c_4}{2}v\right)v + \frac{b_3(\phi + \beta v)}{a} + \\ + \mu \left(gx - \frac{(\phi - \beta v)}{2} \cdot \frac{(\phi + \beta v)}{a} - \gamma v - \frac{\beta(\phi + \beta v)v}{a} \right) + \\ + \psi((\rho_1 - g)\lambda + c_1)$$

while the maximization condition $\partial H_2 / \partial v = 0$ finally yields

$$-c_4v + b_2 + \frac{b_3\beta}{a} + \mu \left(-\frac{\beta(\phi + \beta v)}{2a} - \frac{(\phi - \beta v)\beta}{2a} - \gamma - \frac{\beta^2v}{a} \right) = 0$$

and the follower's optimal strategy is easily obtained as (solving the maximization condition)

$$\hat{v}_S = \frac{a(b_2 - \hat{\mu}\gamma) - \beta(\hat{\mu}\phi - b_3)}{c_4a + \hat{\mu}\beta^2}$$

repeating similar steps as before we calculate the Stackelberg leader's optimal strategy as

$$\hat{u}_S = \frac{\beta(b_2 - \hat{\mu}\gamma) + c_4\phi + b_3(\beta^2/a)}{c_4a + \hat{\mu}\beta^2}$$

the proof of the expression for the number of polluting firms is the same as in the Nash case. \square

References

- Başar, Tamer, and Geert Jan Olsder. 1999. *Dynamic Noncooperative Game Theory*, 2nd ed. New York: Academic Press.
- Chen, Wanting, and Zhi-Hua Hu. 2018. Using evolutionary game theory to study governments and manufacturers' behavioral strategies under various carbon taxes and subsidies. *Journal of Cleaner Production* 201: 123–41. [CrossRef]
- Dockner, Engelbert, Gustav Feichtinger, and Steffen Jørgensen. 1985. Tractable classes of Non Zero Sum open Loop Nash Differential Games: Theory and Examples. *Journal of Optimization Theory and Applications* 45: 179–97. [CrossRef]
- Dockner, Engelbert J., Steffen Jørgensen, Ngo Van Long, and Gerhard Sorger. 2000. *Differential Games in Economics and Management Science*. Cambridge: University Press.
- Grass, Dieter, Jonathan P. Caulkins, Gustav Feichtinger, Gernot Tragler, and Doris A. Behrens. 2008. *Optimal Control of Nonlinear Processes. With Applications in Drugs, Corruption and Terror*. Berlin and Heidelberg: Springer.
- Gromova, Ekaterina Viktorovna, Anna Viktorovna Tur, and Lidiya Ivanovna Balandina. 2016. A game-theoretic model of pollution control with asymmetric time horizons. *Contributions to Game Theory and Management* 9: 170–79.
- Halkos, George E. 1996. Incomplete information in the acid rain game. *Empirica* 23: 129–48. [CrossRef]
- Halkos, George, and George Papageorgiou. 2014. *Controlling Polluting Firms: Nash and Stackelberg Strategies*. MPRA Discussion Paper 58947. Munich: University Library of Munich.
- Madani, Kaveh. 2010. Game theory and water resources. *Journal of Hydrology* 381: 225–38. [CrossRef]
- Schüller, Katharina, Kateřina Staňková, and Frank Thuijsman. 2017. Game theory of pollution: National policies and their international effects. *Games* 8: 30. [CrossRef]
- Shi, Guang-Ming, Jin-Nan Wang, Bing Zhang, Zhe Zhang, and Yong-Liang Zhang. 2016. Pollution control costs of a transboundary river basin: Empirical tests of the fairness and stability of cost allocation mechanisms using game theory. *Journal of Environmental Management* 177: 145–52. [CrossRef]
- Wang, Hongwei, Lingru Cai, and Wei Zeng. 2011. Research on the evolutionary game of environmental pollution in system dynamics model. *Journal of Experimental & Theoretical Artificial Intelligence* 23: 39–50.
- Wood, Peter John. 2010. *Climate Change and Game Theory. Environmental Economics Research Hub Research Reports*. Canberra: The Crawford School of Economics and Government. Australian National University.
- Zhang, Ming, Hao Li, Linzhao Xue, and Wenwen Wang. 2019. Using three-sided dynamic game model to study regional cooperative governance of haze pollution in China from a government heterogeneity perspective. *Science of the Total Environment* 694: 133559. [CrossRef]
- Zhao, Liuwei, and Shuai Jin. 2021. Research on the Impact of Ecological Civilization Construction on Environmental Pollution Control in China—Based on Differential Game Theory. *Discrete Dynamics in Nature and Society*. [CrossRef]



Article

Spatial Patterns in Fiscal Impacts of Environmental Taxation in the EU

Vít Pászto ^{1,2}, Jarmila Zimmermannová ^{2,*}, Jolana Skaličková ² and Judit Sági ³

¹ Department of Geoinformatics, Palacký University Olomouc, 17. listopadu 50, 77146 Olomouc, Czech Republic; vit.paszto@gmail.com

² Department of Computer Science and Applied Mathematics and Department of Economics, Moravian Business College Olomouc, tř. Kosmonautů 1288/1, 779 00 Olomouc, Czech Republic; jolana.skaliczkova@mvso.cz

³ Finance Department, Budapest Business School, University of Applied Sciences, Buzogány u. 10-12, H-1149 Budapest, Hungary; sagi.judit@uni-bge.hu

* Correspondence: jarmila.zimmermannova@mvso.cz; Tel.: +420-724-444-374

Received: 16 September 2020; Accepted: 17 November 2020; Published: 20 November 2020

Abstract: There are several reasons for environmental taxation implementation. Besides its environmental impact, the main reason for such taxation is its fiscal impact, particularly in generating revenues of public budgets. The main goal of this paper is to observe possible spatial patterns in fiscal impacts of environmental taxation in the EU countries, and to depict the groups of countries with the same (or similar) fiscal impact of these instruments on public budget revenues, including environmental and economic characteristics. Two methods of cluster analysis are used, Ward linkage and K-nearest neighbors (spatial) cluster analysis to observe potential geographical links or implication of fiscal impact. The study is performed for the years 2008 and 2017. Based on the results, we can say that in the year 2008, the EU countries were divided into “the west” and “the east”, with some exceptions. The western countries were characterized by high environmental tax revenues, the eastern countries by low environmental tax revenues. For 2017, the situation is different. The border between old and new EU member states is not so abrupt and clear. The results show higher diversification between EU countries concerning the fiscal impacts of environmental taxation.

Keywords: environmental taxation; EU ETS; fiscal impact; cluster analysis; spatial patterns

JEL Classification: H23; Q58

1. Introduction

Currently, raising revenues and addressing climate change are two fundamental challenges facing governments (Barrage 2020). The European Union (EU) member states use various economic instruments of environmental/climate protection. The range of instruments includes, among others, environmental taxes, fees, charges, tradable permits, deposit-refund systems and subsidies (Eurostat 2013; European Commission 2016). Environmental taxes should play an essential part in environmental policy as they help to internalize externalities, reduce damage and increase the quality of life; they also allow for the raising of revenue for national and local governments (Jurušs and Brizga 2017). Therefore, besides their environmental impact, the main reason for these economic instruments’ implementation is their fiscal impact—namely, the revenues of public budgets (OECD 2016).

The EU has increasingly favored such instruments because they provide flexible and cost-effective means of reinforcing the polluter-pays principle and for reaching environmental policy objectives (Hájek et al. 2019). Regarding environmental taxation, Eurostat (2013) distinguishes four categories

of environmental taxes: energy taxes (including fuel for transport), transport taxes, pollution taxes and resource taxes. Government revenues from the auctioning of emission permits are treated as tax receipts in the national accounts; therefore, they are part of the energy taxes (Eurostat 2013; European Commission 2016).

Since environmental taxation represents the additional revenues of state/public budgets, the questions might emerge: what is the level of economic burden connected with environmental tax policy in particular EU member states? Are there any common features and trends between countries or groups of countries?

Concerning practically significant studies in this field we can generally divide them into studies focusing on environmental impacts and studies focusing on the fiscal impacts of such taxation. Recent scientific studies in the field of environmental impacts of environmental taxation are mainly case studies for specific countries. A case study of Spain (Gemachu et al. 2014) included an analysis of direct and indirect effects of an environmental tax imposed on Spanish products, using environmental input-output (EIO) and price models. Pereira and Pereira (2014) studied CO₂ taxation in its dual role as a climate and a fiscal policy instrument in Portugal. They developed marginal abatement cost curves for CO₂ emissions associated with CO₂ tax using a dynamic general equilibrium model of the Portuguese economy. Solaymani (2017) focused on carbon and energy taxation in Malaysia. Van Heerden et al. (2016) analyzed the economic and environmental effects of the carbon tax in South Africa, using the dynamic CGE modelling approach. Jurušs and Brizga (2017) assessed the role of environmental taxes used in Latvia's environmental policy, using desk research. Frey (2017) evaluated the impact of different carbon tax levels on the Ukrainian economy and the environment, observing evidence for a robust double dividend. Hájek et al. (2019) analyzed carbon tax efficiency in the energy industries of selected EU countries, finding out that carbon tax is more effective than CO₂ emission trading in these countries.

Dealing with fiscal impacts of environmental taxation, it is worth mentioning the recent research of Barrage (2020), who studied the optimal design of carbon taxes both as an instrument to control climate change and as a part of fiscal policy. Based on the results, the imposition of appropriately designed carbon taxes could yield substantial benefits, both in terms of raising revenues and by significantly improving intertemporal production efficiency. Labandeira et al. (2019) analyzed the possibilities of new green tax reforms, as a consequence of an increased need for public revenues. Their study explores the possibilities of implementing a new generation of green tax reforms in Spain, focusing on various impacts, including public revenues and income distribution from taxing various energy-related environmental damages and by considering fiscal consolidation and funding the costs of renewable energy support schemes.

There are not many studies focusing on the spatial aspect of environmental taxation in this field. For example, Xiangmei and Yang (2018) analyzed spatial issues in China, observing temporal and spatial distribution characteristics of the air pollution index (API) and its correlation with the improvement of environmental tax law. Their paper discussed the general trend of the China air pollution index and studied the daily air pollution index of important cities focusing on the three dimensions of time, space, and trend. For analyzing the relationship of API with environmental tax laws, the authors used methods of studying regional differences in the economic discipline, especially the Searl index. The discussion underlines the topic of how to allocate resources in the redistribution of tax rationally.

Other research papers dealing with spatial aspects carry out firm responses to a carbon price and corporate decision making under British Columbia's (BC) carbon tax (Bumpus 2015). The research is empirical and focuses on firms, which experienced difficulty in making low-carbon changes in response to fluctuating commodity prices, the low certainty of climate policy over temporal and spatial scales and the political economy of implementing regional climate policy. The study presents the results of empirical research of industry participation, and interviews with executives of major emitting firms in BC.

Concerning both fiscal aspects and spatial distribution of environmental taxation, using cluster analysis as a methodological approach, there is a lack of such scientific studies. There are some excise taxation studies, which are close to the environmental topic. For example, [Lin and Wen \(2012\)](#) carry out an analysis of temporal changes in geographical disparities in alcohol-attributed disease mortality (ADM) before and after implementation of the alcohol tax policy in Taiwan. As a methodological approach, they used local spatial statistical methods to explore the geographic variations in ADM rates and identify statistically significant clusters among townships. Then, we can find studies observing spatial patterns in various taxation issues in European countries, as well. For example, [Zaharia et al. \(2017\)](#) focused on the environmental taxation in EU countries and the comparison of clusters in the year 2002 with the year 2012, using Ward linkage cluster analysis. Another study, [Liapis et al. \(2013\)](#), provided clusters of economic similarities between EU countries, calculating with different categories of economic indicators, including tax revenues. However, this analysis does not include all EU countries and the environmental tax revenues are not included in the category “tax revenues”. [Stuhlmacher et al. \(2019\)](#) performed a systematic, spatial-economic assessment of the EU ETS. They analyzed the spatial pattern of emissions changes using clustering analysis of emissions changes at the EU and country-level in the period 2005–2012. [Pászto and Zimmermannová \(2019\)](#) evaluated the development of CO₂ emissions and selected economic indicators of EU-28 countries in the period from 2005 to 2015, capturing the geographical patterns and spatial distribution of countries emitting pollution. [Skovgaard et al. \(2019\)](#) explored patterns of adoption (both implemented policies and those scheduled to be) through cluster analysis to investigate factors that could explain policies’ decisions to adopt carbon pricing. The study contributed empirically by studying carbon taxes and emissions trading together and by clustering the polities adopting carbon pricing.

Currently, there is no such spatial analysis of the fiscal aspects of environmental taxation in EU countries, observing (Central and Eastern Europe) CEE countries in more detail and simultaneously taking EU ETS state budget revenues as a separate category. Moreover, the above-mentioned scientific studies use only one method of cluster analysis—Ward’s or K-nearest neighbors’ method. Focusing on this gap in the scientific field, we carry out the following research.

The main goal of this paper is (1) to observe possible spatial patterns in fiscal impacts of environmental taxation in EU countries, with a focus on CEE countries (comprising of Albania, Bulgaria, Croatia, Czechia, Hungary, Poland, Romania, Slovakia, Slovenia, and the three Baltic States: Estonia, Latvia and Lithuania ([OECD 2019](#)), and (2) to depict the groups of countries with the same (or similar) fiscal impact of these instruments on public budget revenues, including environmental and economic characteristics of analyzed countries.

As an input motivation to our research, we were inspired by the EU document ([European Commission 2019](#)) underlining consequences with environmental taxation: *“In general, two groups of Member States can be distinguished: (1) A group of “low-taxing Member States”. These are typically taxing at rates close to the minima and have often, although not in all cases, introduced taxation only as a consequence of the existence of common minimum rates. Many of the new Member States are in this group (Slovenia is one exception); (2) A group of “high-taxing Member States” with tax levels more or less clearly above the minima. For these countries, the existence of common minima is particularly important to reduce competitive disadvantages for their industry. These countries also often make use of the possibility to apply reduced rates for energy-intensive businesses. The Nordic countries are among the highest taxing Member States, especially for heating fuels”.*

Concerning this document, our research focuses on observing characteristics of environmental tax revenues in EU countries to find possible groups of them. The following research questions are defined:

- (1) Can we observe similar characteristics between Central and Eastern Europe (CEE) countries, as representants of a group of “low-taxing Member States”?
- (2) Can we observe any spatial-temporal changes in groups of countries in general (focusing on the years 2008 and 2017)?

Given the lack of studies focusing on spatial patterns of the environmental taxation, the authors will examine and evaluate (1) possible geographical patterns in the revenues of the environmental taxes within the EU, and (2) provide comprehensive spatial analysis of economic and environmental data of EU-28 countries, with a focus on CEE countries, using two different methods of cluster analysis. As a result, new findings can represent additional information for policymakers both in the EU and CEE countries. They can help them to discuss the possible change in environmental taxation in their countries, concerning both environmental and economic indicators.

2. Methodology

2.1. Data

As the research deals with environmental taxes in EU countries, the key variables in the analysis are environmental tax revenues. EUROSTAT published them in four categories: (1) energy taxes, (2) transport taxes, (3) resource taxes and (4) pollution taxes, whereas EU ETS auction revenues are part of the category energy taxes. For our research, we separated the data for EU ETS revenues and grouped the categories of resource taxes and pollution taxes to one common class. In particular, we used energy taxes revenues, excluding EU ETS revenues in EUR/capita (Eurostat 2020), transport taxes revenues in EUR/capita (Eurostat 2020), pollution and resource taxes revenues in EUR/capita (Eurostat 2020) and EU ETS revenues (EUA auctions) in EUR/capita (EEX 2020; ICE 2019).

In connection with both the economic and environmental background of environmental tax revenues, GDP and greenhouse gas emissions are included as the variables to this analysis, to show us the overall picture within the spatial patterns. The economic power of the country is represented by GDP in EUR per capita (Eurostat 2020); environmental aspects are described by greenhouse gas emissions in tons per capita (Eurostat 2020).

For the analysis, the years 2008 and 2017 were selected. The year 2008 represents the first year of joint energy taxation came into force in all EU countries (including EU countries with a transitional period); moreover, the second phase of the EU ETS started (so-called “Kyoto period” 2008–2012). The year 2017 represents the last year with the availability of all necessary data, in particular, greenhouse gas emissions in tons per capita; simultaneously, results from this year can show us the situation after almost decade of new environmental taxes came into force. Table 1 contains the essential descriptive characteristics of the selected variables for EU-28 countries in the years 2008 and 2017.

Table 1. Descriptive Characteristics of Variables 2008 and 2017.

Variable	Unit	Year	N	Min	Max	Mean	Average
Greenhouse gas emissions	tons/capita	2008	28	5.6	27.5	10.7	11.1
		2017	28	5.5	20.0	8.6	9.3
GDP	EUR/capita	2008	28	4900.0	77,900.0	23,000.0	24,810.7
		2017	28	7300.0	92,600.0	23,500.0	29,200.0
Energy taxes revenues without EU ETS	EUR/capita	2008	28	95.43	1899.28	358.90	444.08
		2017	28	168.4	1471.3	523.4	537.7
EU ETS revenues (EUA auctions)	EUR/capita	2008	28	0.0	0.00	0.00	0.00
		2017	28	4.7	29.91	11.42	12.25
Transport taxes revenues	EUR/capita	2008	28	4.5	774.9	114.9	168.6
		2017	28	9.9	786.6	118.1	169.1
Pollution and resource taxes revenues	EUR/capita	2008	28	0.0	121.8	4.1	13.3
		2017	28	0.0	88.5	3.3	13.9

Source: own processing, based on Eurostat (2020); EEX (2020) and ICE (2019).

There are significant disparities between the minimum and maximum values in all types of environmental tax revenues within the EU countries. On the other hand, focusing on temporal development in these revenues, the disparities were lower in 2017. According to the variable “Energy taxes without EU ETS’ revenues”, the minimum level increased and the maximum level decreased. Simultaneously, the apparent decrease in maximum levels of greenhouse gas emissions in tons/capita in EU countries between the years 2008 and 2017 also represents an interesting trend—for more details see Table 2.

Table 2. Greenhouse gas emissions (tons per capita) in EU28 countries.

Country	2008	2009	2010	2011	2012	2013	2014	2015	2016	2017
EU 28	10.6	9.6	9.8	9.5	9.3	9.1	8.7	8.8	8.7	8.8
Belgium	13.5	12.1	12.7	11.6	11.3	11.2	10.6	11	10.8	10.8
Bulgaria	9	7.9	8.3	9.1	8.4	7.7	8.2	8.7	8.4	8.8
Czechia	14.3	13.3	13.5	13.4	12.9	12.4	12.2	12.3	12.5	12.4
Denmark	12.5	11.9	11.9	10.9	10.1	10.3	9.6	9	9.3	8.9
Germany	12.2	11.4	11.8	11.7	11.8	12	11.4	11.4	11.4	11.2
Estonia	15	12.5	15.9	16	15.2	16.7	16.1	13.9	15	16
Ireland	15.7	14.1	13.9	12.9	12.9	12.9	12.8	13.2	13.5	13.3
Greece	12.2	11.5	10.9	10.7	10.4	9.6	9.4	9.1	8.8	9.2
Spain	9.3	8.3	8	8	7.8	7.2	7.3	7.6	7.4	7.7
France	8.4	8.1	8.1	7.7	7.6	7.6	7.1	7.1	7.1	7.2
Croatia	7.2	6.7	6.6	6.5	6.1	5.8	5.7	5.8	5.9	6.2
Italy	9.6	8.6	8.8	8.6	8.3	7.6	7.2	7.4	7.4	7.3
Cyprus	13.9	13.2	12.5	11.8	11	10.1	10.6	10.7	11.4	11.6
Latvia	5.6	5.4	6	5.8	5.7	5.8	5.8	5.8	5.9	6
Lithuania	7.7	6.4	6.8	7.1	7.2	6.9	6.9	7.1	7.2	7.4
Luxembourg	27.5	25.8	26.5	25.6	24.3	22.7	21.5	20.4	19.8	20
Hungary	7.1	6.5	6.6	6.4	6.1	5.8	5.9	6.2	6.3	6.6
Malta	8.2	7.7	7.9	7.9	8.3	7.5	7.5	5.9	5.1	5.5
Netherlands	13.3	12.8	13.5	12.6	12.3	12.2	11.8	12.2	12.2	12
Austria	10.7	9.8	10.4	10.1	9.7	9.7	9.2	9.3	9.4	9.6
Poland	10.9	10.4	10.9	10.9	10.7	10.6	10.3	10.4	10.6	11
Portugal	7.5	7.2	6.8	6.7	6.5	6.4	6.4	6.9	6.7	7.2
Romania	7.3	6.3	6.2	6.4	6.3	5.8	5.9	5.9	5.8	6
Slovenia	10.7	9.6	9.6	9.6	9.3	8.9	8.1	8.2	8.6	8.4
Slovakia	9.3	8.5	8.6	8.5	8	7.9	7.6	7.7	7.8	8
Finland	13.8	13	14.4	13	11.9	11.9	11.1	10.4	10.9	10.4
Sweden	7.1	6.5	7.1	6.6	6.2	6	5.8	5.7	5.6	5.5
United Kingdom	11.1	10.1	10.2	9.4	9.6	9.3	8.7	8.3	7.9	7.7

Source: own processing, based on Eurostat (2020).

Table 2 shows the average level of EU28 and EU member countries. Regarding the country with the highest emissions per capita in EU28, it is Luxembourg. The countries with a minimal level of greenhouse gas emissions varied in the observed period 2008–2017; it was Latvia in 2008–2012, Latvia, Croatia, Hungary and Romania with the same level 5.8 in 2013, Croatia with 5.7 in 2014, Sweden in 2015 (5.7), Malta in 2016 (5.1) and Malta with Sweden in 2017 (5.5).

2.2. Methodology—Cluster/Grouping Analysis

Two different methods of cluster analysis were selected, calculating with the above-described data sets for years 2008 and 2017. We applied clustering in two umbrella settings: (1) without a spatial component (i.e., clustering of attribute data/indicators only), and (2) with a spatial component, i.e., mutual proximity of EU member states is considered implicitly in the cluster analysis. The cluster analysis is often applied to analyze territorial units, e.g., in the regional analysis of the localization of large enterprises (Skaličková 2018) or research focused on the development of heterogeneity of EU countries (Rozmahel et al. 2013). Preliminary results of authors’ research dealing with environmental

taxation in Europe were focused on the years 2008 and 2017; then, different methods of cluster analysis were performed. Based on the obtained results and due to the similar historical development and generally lower level of environmental awareness, CEE countries were selected for detailed evaluation.

In general, cluster analysis methods are used to differentiate objects into a system of categories, which on the one hand document the similarities of objects within a single category and on the other hand underline the differences of objects falling into different categories (Maršík and Kopta 2013). These methods are based on the usage of the rate of conformity (or rather non-conformity) of objects and clusters. This rate of non-conformity is expressed as the Euclidian distance between the two vectors Y and Z in Formula (1):

$$v_{YZ} = \sqrt{\sum_{i=1}^k (y_i - z_i)^2} \quad (1)$$

Firstly, we used hierarchical procedures, i.e., gradual clustering, including the combinations of objects into clusters. The result is the construction of a hierarchy, or dendrogram (tree-like structure), depicting the formation of the cluster (Hair et al. 2010). Esri (2016) describes this process as “a solution where all the features within each group are as similar as possible, and all the groups themselves are as different as possible.” For non-spatial clustering (i.e., ignoring the proximity of EU countries), Ward’s linkage method was applied in this paper. Ward’s linkage method minimizes the sum of squares of any two theoretical clusters, which can be generated at every step of clustering (Ward 1963). Ward’s method is treated as relatively efficient, and it considers the size of the data sample. As a result, the optimal number of clusters should be depicted. It must be noted that there exist various clustering algorithms (e.g., frequently used k-means); however, Ward’s clustering is believed to be ideally used if a certain number of groups is not known a priori. In comparison with k-means, k-means perform computationally faster when having many variables and a small number of target clusters (Soetewey 2020). In our case, we have a relatively small number of variables (see Table 1); thus, the computational time was not an issue, and the target number of clusters was unknown. Generally, hierarchical clustering returns a more informative and interpretative cluster than k-means. Therefore, we chose Ward’s method as the most appropriate one as regards the task we faced. Nevertheless, it is still in discussions which method is more suitable for which data or task; leading to a statement that clustering is a rather subjective statistical analysis (depending on the data and task to be solved).

Secondly, to underline the spatial relationship between the countries, the K-nearest neighbors (KNN) linkage method was applied. In general, this algorithm belongs to the techniques of machine learning or pattern recognition. Specifically, it uses the K-nearest neighbors of the given feature (individual EU-28 country in this case) to classify that feature into a group of neighbors. According to Everitt et al. (2011), two observations x_i and x_j are neighbors if:

$$d(x_i, x_j) \leq d_k(x_i) \text{ OR } d_k(x_j), \quad (2)$$

where d is the Euclidean metric and $d_k(x_i)$ is the k th nearest-neighbor distance to point x_i .

The algorithm represents a relatively “straightforward” procedure, which requires a pre-set of the number of neighbors to look around. Often, it is treated as a supervised classification algorithm just because of the user-defined neighborhood. The algorithm is very well adopted when dealing with geographic space, as it is a distance-based algorithm, which relies on a metric (2D feature space). For a detailed description of the algorithm, see, e.g., Theodoridis and Koutroumbas (2006) or Everitt et al. (2011). The number of neighbors for our purposes was set to be six, and the algorithm searched for them in terms of Euclidean distances (i.e., straight lines between country center points). The choice of this method was based on previous experience and use by the authors (Pászto and Zimmermannová 2019), and also due to the fact that it was necessary to determine the target number of groups (based on non-spatial cluster analysis in the first part). It is important to mention that the cluster analysis takes into account both a spatial component (XY coordinates) and the

input indicators' value. More examples of the clustering usage for geographically located data can be found in [Marek et al. \(2015\)](#).

3. Results

3.1. Non-Spatial Clustering

Firstly, the correlation analysis was performed for finding out the variables with the correlation coefficient higher than 0.9, which could distort the results of further investigation. As a result, there are no statistically significant relationships between analyzed variables. The data was standardized by the standard deviation for cluster analysis purposes. The number of observations was 28 for each variable.

Secondly, for non-spatial clustering, Ward's linkage method was used. Tables 3 and 4 show the way the countries are grouped at each stage of the cluster analysis. This process continues until the moment all the EU countries are grouped in one large cluster, which is represented by line 27. The coefficients represent the distances between two countries or two already created clusters, joined on the next level. The next part of the table shows the phase when clusters emerge. The last column shows the stage when the newly created cluster is combined with another, already existing cluster.

Table 3. Agglomeration schedule (the year 2008).

Stage	Cluster Combined		Coefficients	Stage Cluster First Appears		Next Stage
	Cluster 1	Cluster 2		Cluster 1	Cluster 2	
1	15	21	0.015	0	0	12
2	2	25	0.051	0	0	9
3	3	14	0.112	0	0	13
4	5	24	0.203	0	0	18
5	9	22	0.297	0	0	17
6	7	19	0.401	0	0	11
7	12	28	0.515	0	0	14
8	11	17	0.681	0	0	12
9	2	23	0.907	2	0	13
10	1	18	1.159	0	0	18
11	7	20	1.474	6	0	19
12	11	15	1.818	8	1	17
13	2	3	2.225	9	3	21
14	12	27	2.668	7	0	20
15	10	13	3.194	0	0	20
16	6	8	4.105	0	0	21
17	9	11	5.155	5	12	23
18	1	5	6.294	10	4	22
19	7	26	7.885	11	0	22
20	10	12	9.955	15	14	23
21	2	6	12.992	13	16	26
22	1	7	16.950	18	19	25
23	9	10	23.089	17	20	26
24	4	16	31.157	0	0	25
25	1	4	40.301	22	24	27
26	2	9	59.518	21	23	27
27	1	2	81.000	25	26	0

Source: own processing.

Table 4. Agglomeration schedule (the year 2017).

Stage	Cluster Combined		Coefficients	Stage Cluster First Appears		Next Stage
	Cluster 1	Cluster 2		Cluster 1	Cluster 2	
1	11	14	0.136	0	0	6
2	2	25	0.414	0	0	10
3	12	28	0.724	0	0	11
4	9	15	1.048	0	0	8
5	1	5	1.404	0	0	15
6	11	22	1.772	1	0	17
7	19	20	2.498	0	0	14
8	9	17	3.236	4	0	17
9	3	21	3.976	0	0	12
10	2	23	4.764	2	0	19
11	12	24	5.643	3	0	18
12	3	8	6.758	9	0	19
13	10	27	7.894	0	0	18
14	7	19	9.070	0	7	16
15	1	13	10.455	5	0	20
16	7	26	12.181	14	0	20
17	9	11	14.284	8	6	21
18	10	12	16.616	13	11	22
19	2	3	18.992	10	12	23
20	1	7	23.451	15	16	24
21	9	18	28.843	17	0	22
22	9	10	36.540	21	18	26
23	2	6	51.428	19	0	26
24	1	16	72.095	20	0	25
25	1	4	95.251	24	0	27
26	2	9	118.657	23	22	27
27	1	2	162.000	25	26	0

Source: own processing.

Figure 1 presents the results of non-spatial cluster analysis for the year 2008, the dendrogram using Ward linkage. It shows detected similarities between countries. Based on the dendrogram, we can distinguish the following clusters:

- cluster 1, represented by low GDP and low environmental taxes revenues—mostly new EU member states (Czechia, Malta, Portugal, Slovenia, Bulgaria, Romania, Lithuania, Poland, Estonia, Slovakia, Croatia, Latvia, Hungary);
- cluster 2, represented by high GDP and high environmental taxes revenues (Denmark, Ireland, Netherlands, Sweden, Austria, Finland, Germany, UK, France, Belgium, Spain, Cyprus, Greece, Italy);
- cluster 3, represented by one country with the highest GDP and energy taxes revenues (Luxembourg).

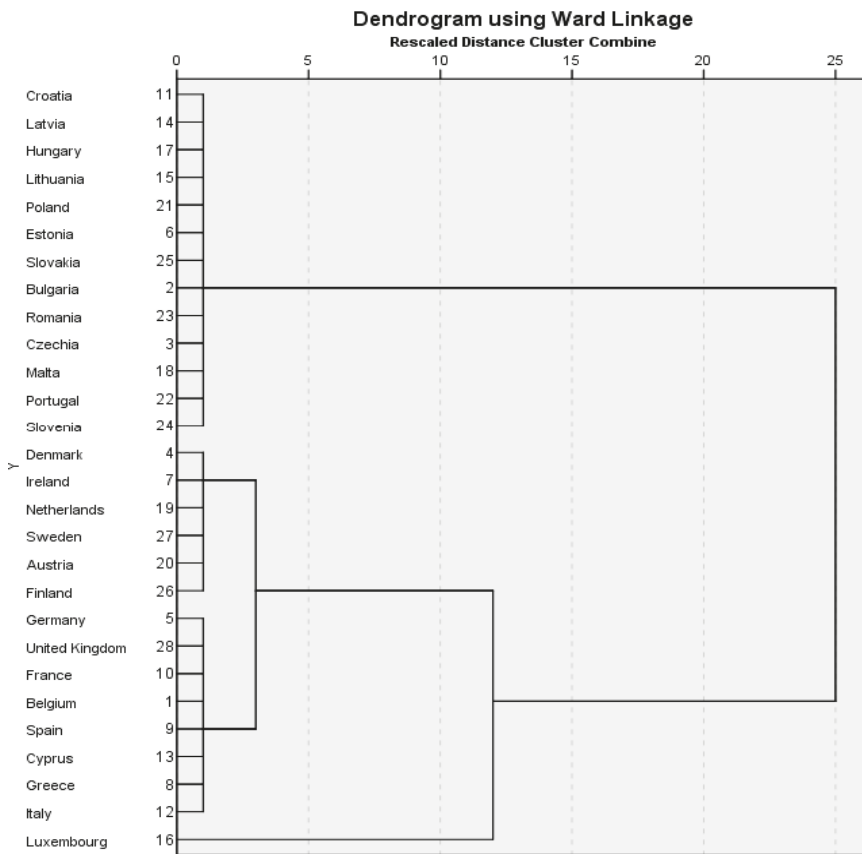

Figure 1. Results of non-spatial cluster analysis for EU countries in the year 2008—Ward linkage.

Figure 2 presents the result of non-spatial cluster analysis for the year 2017, the dendrogram using Ward linkage. We can distinguish the following clusters:

- cluster 1, represented by low CO₂ emissions, middle tax revenues and low EU ETS revenues (Croatia, Latvia, Portugal, Spain, Lithuania, Hungary, Malta);
- cluster 2, represented by low CO₂ emissions, high tax revenues and low EU ETS revenues (Italy, UK, Slovenia, France, Sweden);
- cluster 3, characterized by increased CO₂ emissions, low tax revenues, high EU ETS revenues and low GDP (Bulgaria, Slovakia, Romania, Czechia, Poland, Greece);
- cluster 4, represented by one country with the lowest transport tax revenues, high CO₂ emissions and the highest EU ETS revenues (Estonia);
- cluster 5, characterized by increased CO₂ emissions, high transport tax revenues and high energy tax revenues (Belgium, Germany, Cyprus, Netherlands, Austria, Ireland, Finland);
- cluster 6, represented by one country with the highest CO₂ emissions and too high tax revenues (Luxembourg);
- cluster 7, represented by one country with low CO₂ emissions and too high tax revenues (Denmark).

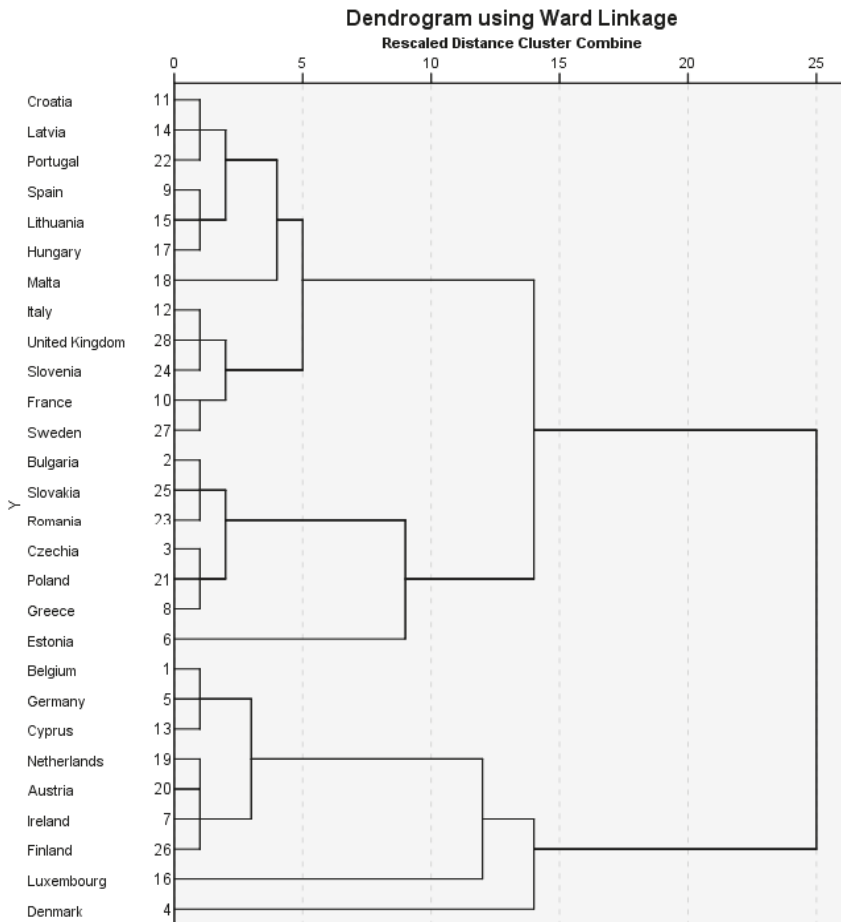

Figure 2. Results of non-spatial cluster analysis for EU countries in the year 2017—Ward linkage.

3.2. Spatial Clustering

By using the spatial method of cluster analysis, K-nearest neighbors, the results are similar, and the clusters are only slightly different. It is worth noting that for both spatial cluster analyses (for 2008 and 2017), the target number of clusters was based on the results from non-spatial clustering. It allowed us to provide results comparable within the particular year.

However, as regards the year 2008, when three target clusters (as classified above) was used, the spatial clustering resulted in one cluster containing one country (Luxembourg). This cluster is in line with cluster 3 (using non-spatial clustering). The second cluster consisted of Ireland, Netherlands and Denmark (all in cluster 2 in the non-spatial cluster analysis; together with other countries), and the third cluster contained all 24 remaining countries. Therefore, we decided to test four clusters as a target number (in line with Figure 1 at the level of 2.5 rescaled cluster distance). Again, the result was not satisfactory since the spatial clustering algorithm subtracted only Denmark from the second cluster from the previous step. The “big block” of the remaining 24 countries stayed the same. Consequently, by spatial clustering, we subdivided the “big block” cluster into two separate ones having the final

number of five clusters as a result (Figure 3). We decided to keep this division although it is not directly comparable with three clusters from non-spatial clustering.

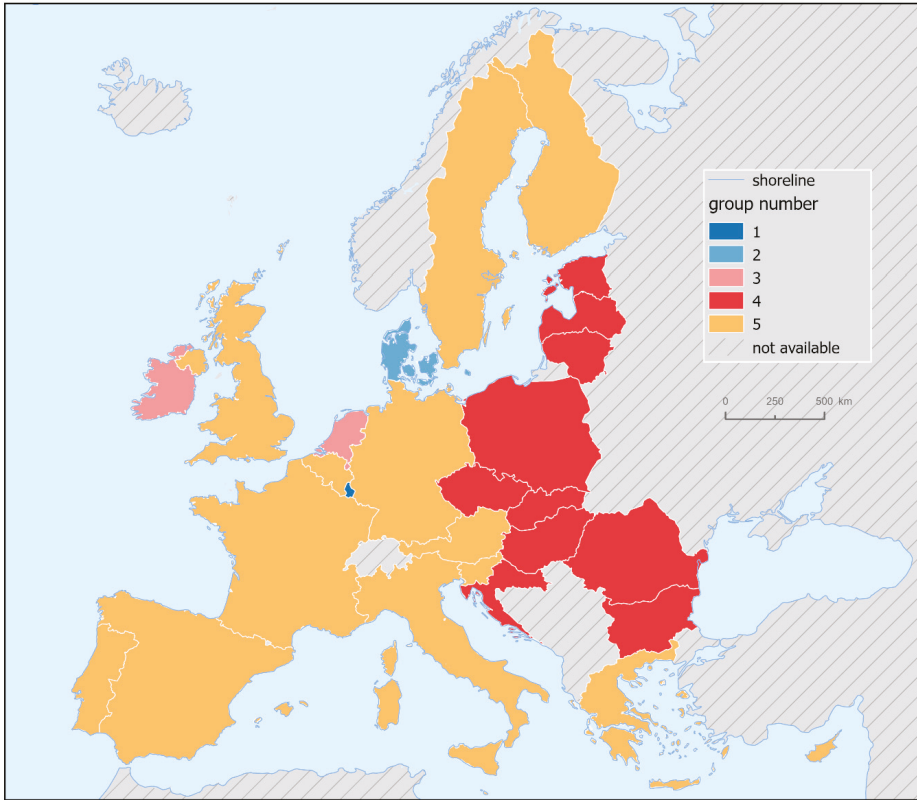

Figure 3. Results of spatial cluster analysis for EU countries in the year 2008 (K-nearest neighbors).

The reason why the Clusters 4 and 5 (former “big block”) were further split in the next step of spatial clustering is evident in Figure 4. The lines follow the opposite trend in energy tax revenues, transport taxes revenues and GDP; almost all of them touching the lower (Cluster 4) or upper (Cluster 5) boundary of IQR (interquartile range). Greenhouse gas emissions are slightly above average in the case of Cluster 5, in case of Cluster 4 around the median. Both clusters evince higher-than-median values in the indicator of pollution and resource taxes. Geographically, both clusters form a majority of “continental” Europe (Great Britain, Norway and Sweden are tight together with “continental” Europe in this case). This result might be explained by mutual geographical proximity and also by the relative similarity of input values. However, it is also evident that Europe is divided into two parts—“east” (Cluster 4) and “west” (Cluster 5)—which might correspond to former geopolitical situations and the history of European countries.

Figure 5 shows the results of spatial cluster analysis for the year 2017. There are three one-member clusters (Luxembourg, Denmark and Estonia); which is in line with findings from non-spatial clustering. Figure 6 shows the parallel box plots as a result of the spatial clustering in 2017. It pinpoints the underlying reasons (from a data perspective) of clustering results and emphasizes individual standardized values of input data.

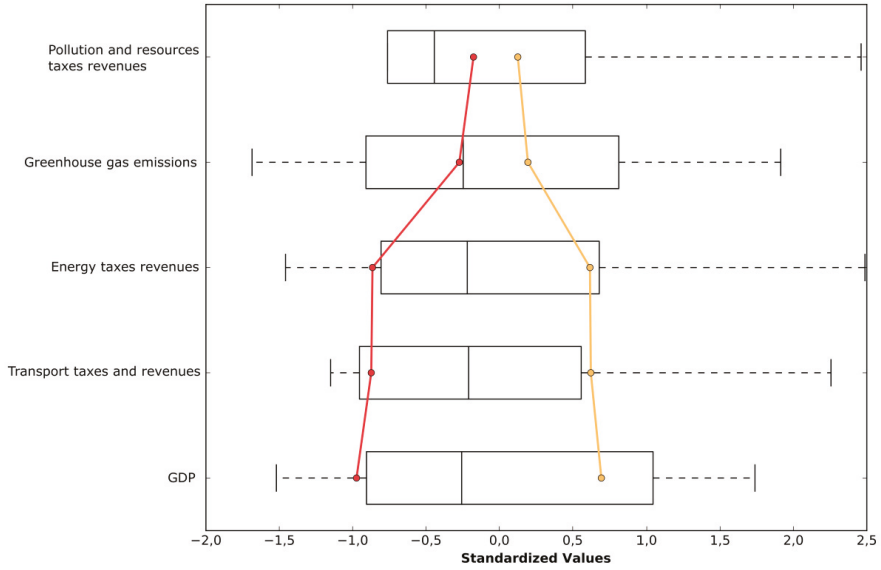

Figure 4. Parallel box plots for cluster 4 and 5, the year 2008.

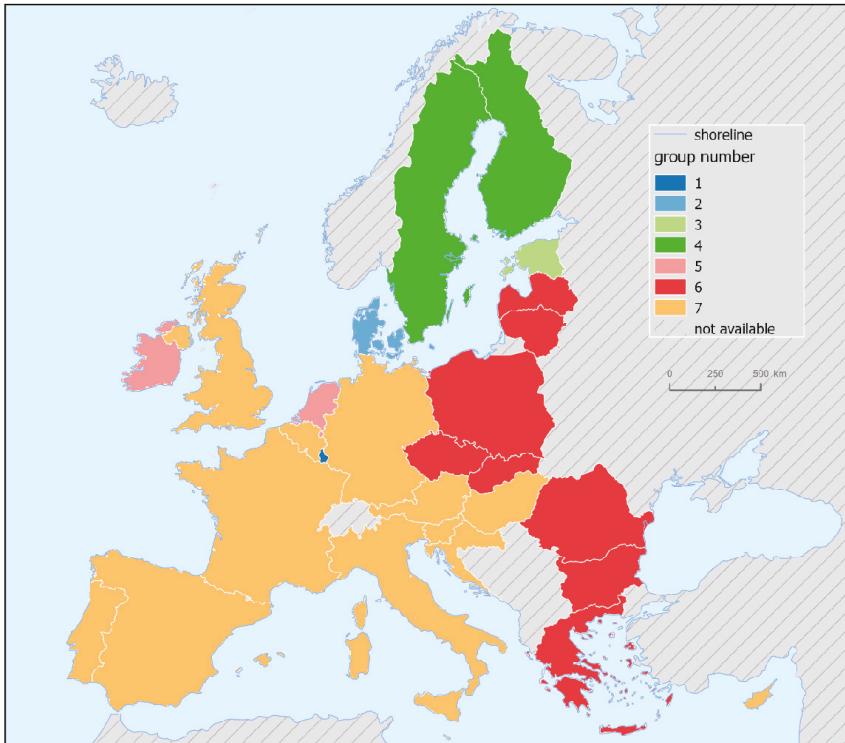

Figure 5. Results of spatial cluster analysis for EU countries in the year 2017 (K-nearest neighbours).

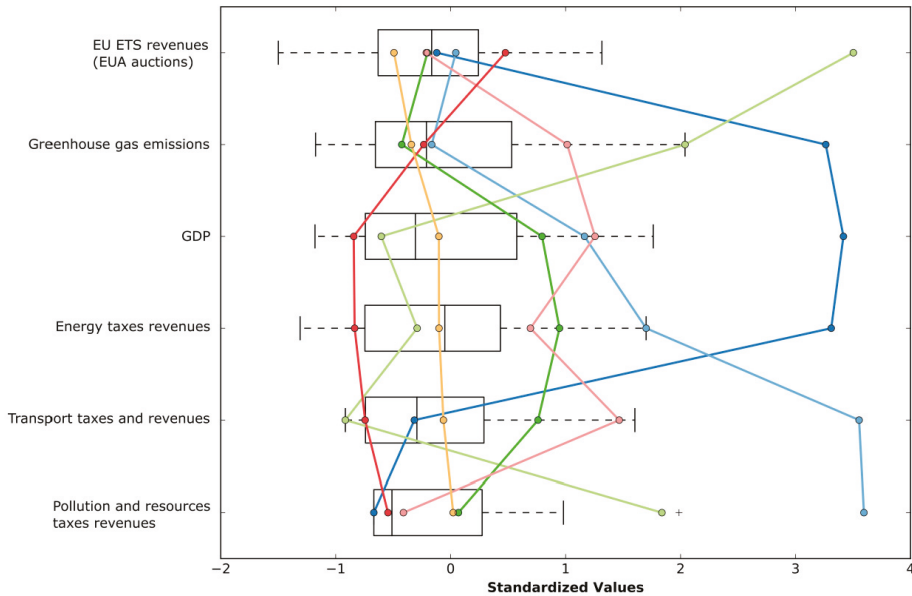

Figure 6. Parallel box plots for four target clusters, the year 2017.

We can see that the newly formed Cluster 3 (Estonia) expresses extreme values in greenhouse gas emissions, and EU ETS’ revenues (the greatest by far in comparison with other countries/groups). Cluster 1 (Luxembourg) has significantly higher values of greenhouse gas emissions, GDP per capita and energy tax revenues. Similarly, Cluster 2 (Denmark) has extreme values of energy, transport, pollution and resource taxes revenues. Cluster 5 (the Netherlands and Ireland) are typically significantly high (out of IQR) in values of greenhouse gas emissions, GDP per capita, energy and transport taxes revenues, which kept them in a separate cluster. A similar curve trend can be observed in the case of Cluster 4 (Sweden and Finland). The values of input indicators are significantly distinct from Cluster 5, which resulted in the formation of a separate cluster of these Scandinavian countries. Cluster 6 (“east” countries) have all their input indicators’ values (except EU ETS’ revenues) below the average/median. Lastly, Cluster 7 (“west” countries) exposes the input indicators’ values remaining within IQR, moving around the average/median. This cluster could be characterized as “balanced”.

4. Discussion

Based on the results, two interesting observations occur. Firstly, regarding the significance of environmental taxation within the public budgets, EU countries are no longer that strongly divided into the eastern and western parts, as they were in the year 2008. Focusing on the year 2017, we can see a more diverse composition of EU countries in terms of newly formed clusters. Secondly, some countries of Central and Eastern Europe (e.g., Hungary, Slovenia, and Croatia) moved to “western clusters”; Estonia is separated in the new cluster.

Tables 5 and 6 depict and compare the most typical features of individual clusters, both non-spatial and spatial ones, in the year 2008 and the year 2017, respectively. CEE countries are highlighted in both tables.

Table 5. Common features of clusters in 2008.

Non—Spatial Clusters	Spatial Clusters	Common Features
Czechia, Malta, Portugal, Slovenia, Bulgaria, Romania, Lithuania, Poland, Estonia, Slovakia, Croatia, Latvia, Hungary	Czechia, Malta, Portugal, Slovenia, Bulgaria, Romania, Lithuania, Poland, Estonia, Slovakia, Croatia, Latvia, Hungary	low emissions & low tax revenues
Denmark, Ireland, Netherlands, Sweden, Austria, Finland, Germany, UK, France, Belgium, Spain, Cyprus, Greece, Italy	Sweden, Austria, Finland, Germany, UK, France, Belgium, Spain, Cyprus, Greece, Italy	high emissions & high tax revenues
Luxembourg	Luxembourg	extra high emissions & extra high energy tax revenues & low other revenues
	Denmark	middle emissions & high tax revenues
	Ireland, Netherlands	high emissions & middle tax revenues

Source: own processing.

Table 6. Common features of clusters in 2017.

Non—Spatial Clusters	Spatial Clusters	Common Features
Croatia, Hungary, Latvia, Lithuania, Malta, Portugal, Spain	Croatia, Hungary, Malta, Portugal, Spain, Belgium, Germany, Cyprus, Austria, Ireland, Italy, the UK, Slovenia, France	middle emissions & middle revenues
Italy, the UK, Slovenia, France, Sweden	Sweden, Finland	low emissions & high tax revenues
Bulgaria, Slovakia, Romania, Czechia, Poland, Greece	Bulgaria, Slovakia, Romania, Czechia, Poland, Latvia, Lithuania, Greece	middle emissions & extremely low GDP & low tax revenues & high EU ETS revenues
Estonia	Estonia	high emissions & low tax revenues & the highest EU ETS revenues
Belgium, Germany, Cyprus, Netherlands, Austria, Ireland, Finland	Ireland, Netherlands	middle emissions & high tax revenues
Luxembourg	Luxembourg	highest emissions & highest GDP & highest energy tax & low other revenues

Table 6. Cont.

Non—Spatial Clusters	Spatial Clusters	Common Features
		middle emissions &
Denmark	Denmark	high tax revenues &
		highest transport and pollution taxes revenues

Source: own processing.

There are seven distinct groups of countries in the year 2017 (Table 6). Most of the CEE countries are represented predominantly by low tax revenues and high EU ETS revenues, except Croatia, Hungary and Estonia. The deeper observation shows us that in the case of the EU ETS, the revenues from auctions go in parallel with the amount of greenhouse gas emissions. That means the countries with high emissions report high revenues from EU ETS auctions. Concerning taxes, environmental tax revenues are various, regardless of the level of emissions. That means the countries with high emissions can have low, middle and high environmental tax revenues. From the opposite view, the countries with low emissions can have low, middle and high environmental tax revenues, too. It shows us spatial patterns in national priorities and goals connected with environmental taxes and more generally, connected with public budget revenues and economic policy.

Focusing on EU countries, we can find common features of environmental taxation connected with energy taxes and the EU ETS, whereas various EU directives give the rules. On the other hand, in several EU member states national or even local environmental taxes are in force, mainly in the domains of transportation, resources, pollution and products taxation.

Regarding our first research question (“Are there similar characteristics between CEE countries?”), at the beginning of our research we anticipated the answer should be “yes” since a common history and economic structure characterize CEE countries. Based on the results, in the year 2008, the countries were grouped in one cluster, using both methods of cluster analysis. However, in 2017, the situation changed; CEE countries were found to not be grouped only in one cluster, using both methods of cluster analysis. There were several CEE countries in the year 2017 with higher environmental taxation revenues connected with a more active approach to environmental taxes within fiscal policy. This was the case with Slovenia, Croatia, and Hungary. In the case of Hungary, for example, environmental taxes accounted for 2.53% of GDP in 2017 (EU-28 average: 2.4%) and energy taxes for 1.91% of GDP (EU average 1.84%) (Eurostat 2020). The significance of these governmental revenues is revealed by the fact that in the year 2017, environmental tax revenues amounted to 6.6% of total revenues from taxes and social security contributions (EU average 5.97%). Out of this 6.6%, however, the excise tax on the fuel for transport purposes only represented nearly 5%. Following EU emission standards, vehicle registration tax is based on environmental protection considerations, with lower (and sometimes no) rates on hybrid and electric cars. Besides these taxes, pollution-related taxes became more emphatic in the past years in Hungary, including the environmental product fee to cover waste management costs. Lastly, the air, water and soil resource charges were in force throughout the examined period as well (Magyar Nemzeti Bank MNB).

As a result of the second research question (“Are there any changes in time, focusing on the years 2008 and 2017?”), we can say that “yes”—there is higher diversification of EU member states in the year 2017.

Concerning the key aspects of fiscal policy, the focus of the policymakers and their policy goals should be defined. As was depicted above, environmental taxes have both fiscal and environmental impacts. The key issue is the major decision of policymakers regarding the level of economic burden connected with environmental protection. Policymakers should generally consider why there are some countries with lower tax revenues than others. As the regional or geographic differentiation also matters, policymakers should take into account local/national characteristics as well. As Juruš and Brizga (2017)

pointed out, politicians rarely take environmental considerations into account, but mostly follow the fiscal aims of the tax and socio-economic arguments trying to balance outside pressure (arising from the European Union environmental policy and acts) and the interests of domestic social partners (business and trade unions). Dealing with EU ETS revenues, some countries are probably better traders and can earn more money from the auctions since the auction prices depend on current demand on the exchange (Pászto and Zimmermannová 2019). According to the significant increase in the price of emission allowances in the period 2018–2020 (from approx. 7 EUR/EUA until approx. 30 EUR/EUA), the influence of revenues from EU ETS auction on state budgets would rise.

Comparing the results with other scientific studies, Liapis et al. (2013) identified that notable groups of countries are Belgium and Italy, Greece and Portugal, Germany and Austria, Finland and Sweden. The other countries are left alone. However, this analysis did not include all EU countries and the environmental tax revenues were not included in the category “tax revenues”. Zaharia et al. (2017) focused on environmental taxation in EU countries, calculated with EU ETS as a part of energy taxes. This study identified the following clusters in the year 2012: cluster 1 comprises Bulgaria, the Czech Republic, Germany, Estonia, Latvia, Luxembourg, Hungary, Poland, Portugal, Sweden, United Kingdom; cluster 2 includes Greece, Italy, Cyprus, Malta, Austria, Finland; cluster 3 consists of Spain, France, Lithuania, Romania, Slovakia; cluster 4 composes of Belgium, Ireland, Iceland and Norway; cluster 5 includes Denmark, Croatia and Netherlands and cluster 6 consists of only one country: Slovenia.

It is important to mention that the cluster analysis is very sensitive to initial settings in both quality and quantity input data (missing values, number of indicators, etc.). Therefore, proper interpretation should be made very carefully.

Regarding the following research, it would be worthwhile to observe yearly changes in clusters in EU countries and the mapping movements of countries between the clusters in more detail. By doing so, we can try to find the groups of countries with the same fiscal policy focus, precisely if their environmental taxes are more transport sector pollution- or energy sector pollution-oriented. It can help focus on changes in policies and trends in the EU as a whole, and in particular countries.

5. Conclusions

The main goal of this paper was to observe possible spatial patterns in fiscal impacts of environmental taxation in EU28, and to depict the groups of countries with the same (or similar) fiscal impact of these instruments on public budget revenues, including environmental and economic characteristics of analyzed countries. For possible spatial pattern identification, the authors used two different methods of cluster analysis, Ward linkage and K-nearest neighbours (spatial) cluster analysis. The analysis was performed for the year 2008 and the year 2017; the year 2008 represents the start of the Kyoto period of the EU ETS; the year 2017 is the last year with all available data and simultaneously can show us the situation after almost decade.

Results show us that in the year 2008, the EU countries were divided into “the west” and “the east”, with some exceptions. The western countries were characterized by high environmental tax revenues, the eastern countries by low revenues. If we focus on the year 2017, the situation is different. The border between old and new EU member states is not so clear. The results show higher diversification between EU countries, concerning the fiscal impacts of environmental taxation. There are seven various groups of countries; low tax revenues and high EU ETS revenues, except for Croatia, Hungary and Estonia, represent most of CEE countries predominantly. The more in-depth observation shows us that in the case of the EU ETS, the revenues from auctions go in parallel with the amount of greenhouse gas emissions. Concerning taxes, environmental tax revenues are various, regardless of the level of emissions. It expresses possible spatial patterns in national priorities and goals connected with various kinds of environmental taxes, and more generally, connected with public budget revenues and economic policy.

This study represents an additional source of information for policymakers, both in CEE countries and the whole EU; it can help them to plan possible changes in environmental taxation, concerning

public budget revenues. Moreover, the results of this study fill the gap in the environmental tax analyses field by uncovering spatial patterns of environmental taxation revenues within the EU.

Author Contributions: Conceptualization, V.P. and J.Z.; methodology, V.P., J.Z. and J.S. (Jolana Skalickova); software, V.P.; validation, V.P., J.Z. and J.S. (Judit Sági); formal analysis, V.P.; investigation, J.Z.; resources, J.S. (Jolana Skalickova) and J.S. (Judit Sági); data curation, J.S. (Jolana Skalickova); writing—original draft preparation, J.Z.; writing—review and editing, V.P.; visualization, V.P.; supervision, V.P. and J.Z.; project administration, V.P.; funding acquisition, V.P. All authors have read and agreed to the published version of the manuscript.

Funding: This paper was created with the support of the European Union, Erasmus+ programme, grant number 2019-1-CZ01-KA203-061374 (Spatiomomy 2.0) and Jean Monnet Module, grant number 621195-EPP-1-2020-1-CZ-EPPJMO-MODULE (EuGeo).

Conflicts of Interest: The authors declare no conflict of interest. The funders had no role in the design of the study; in the collection, analyses, or interpretation of data; in the writing of the manuscript, or in the decision to publish the results.

References

- Barrage, Lint. 2020. Optimal Dynamic Carbon Taxes in a Climate–Economy Model with Distortionary Fiscal Policy. *The Review of Economic Studies* 87: 1–39. [CrossRef]
- Bumpus, Adam. G. 2015. Firm responses to a carbon price: corporate decision making under British Columbia’s carbon tax. *Climate Policy* 15: 475–93. [CrossRef]
- EEX. 2020. Emission Spot Primary Market Auction Report 2017. Available online: <https://www.eex.com/en/market-data/environmental-markets/eua-primary-auction-spot-download> (accessed on 20 April 2020).
- Esri. 2016. How Grouping Analysis Works. Available online: <https://desktop.arcgis.com/en/arcmap/10.3/tools/spatial-statistics-toolbox/how-grouping-analysis-works.htm> (accessed on 10 September 2020).
- European Commission. 2016. The EU Emissions Trading System (EU ETS). European Union. Available online: https://ec.europa.eu/clima/sites/clima/files/factsheet_ets_en.pdf (accessed on 10 January 2020).
- European Commission. 2019. Evaluation of the Council Directive 2003/96/EC of 27 October 2003 Restructuring the Community Framework for the Taxation of Energy Products and Electricity SWD (2019) 332 Final. Available online: <https://ec.europa.eu/transparency/regdoc/rep/10102/2019/EN/SWD-2019-332-F1-EN-MAIN-PART-1.PDF> (accessed on 10 January 2020).
- Eurostat. 2013. Environmental Taxes: A Statistical Guide. Available online: <https://ec.europa.eu/eurostat/web/products-manuals-and-guidelines/-/KS-GQ-13-005> (accessed on 10 January 2020).
- Eurostat. 2020. Environmental Tax Revenues. Available online: https://appsso.eurostat.ec.europa.eu/nui/show.do?dataset=env_ac_tax&lang=en (accessed on 20 April 2020).
- Everitt, Brian S., Sabine Landau, Morven Leese, and Daniel Stahl. 2011. *Cluster Analysis*, 5th ed. Hoboken: Wiley.
- Frey, Miriam. 2017. Assessing the impact of a carbon tax in Ukraine. *Climate Policy* 17: 378–96. [CrossRef]
- Gemechu, Eskinder Demisse, Isabela Butnar, Maria Llop, and Francesc Castells. 2014. Economic and environmental effects of CO₂ taxation: an input-output analysis for Spain. *Journal of Environmental Planning and Management* 57: 751–68. [CrossRef]
- Hair, Joseph, William C. Black, Barry J. Babin, and Rolph E. Anderson. 2010. *Multivariate Data Analysis*. Upper Saddle River: Prentice Hall.
- Hájek, Miroslav, Jarmila Zimmermannová, Karel Helman, and Ladislav Rozenský. 2019. Analysis of carbon tax efficiency in energy industries of selected EU countries. *Energy Policy* 134: 110955. [CrossRef]
- ICE. 2019. EUA UK Auction. Available online: <https://www.theice.com/products/18997864/EUA-UK-Auction-Daily-Futures> (accessed on 20 April 2020).
- Jurušs, Māris, and Janis Brizga. 2017. Assessment of the environmental tax system in Latvia. *NISPAcee Journal of Public Administration and Policy* 10: 135–54. [CrossRef]
- Labandeira, Xavier, José M. Labeaga, and Xiral López-Otero. 2019. New Green Tax Reforms: Ex-Ante Assessments for Spain. *Sustainability* 11: 5640. [CrossRef]
- Liapis, Konstantinos, Antonis Rovolis, Christos Galanos, and Eleftherio Thalassinou. 2013. The Clusters of Economic Similarities between EU Countries: A View Under Recent Financial and Debt Crisis. *European Research Studies* 16: 41. [CrossRef]

- Lin, Chih-Ming, and Tzai-Hung Wen. 2012. Temporal changes in geographical disparities in alcohol-attributed disease mortality before and after implementation of the alcohol tax policy in Taiwan. *BMC Public Health* 12: 889. [CrossRef] [PubMed]
- Marek, Lukáš, Vít Pászto, and Pavel Tuček. 2015. Using clustering in geosciences: examples and case studies. Paper presented at 15th International Multidisciplinary Scientific Geoconference, Informatics, Geoinformatics and Remote Sensing, Albena, Bulgaria, 18–24 June; vol. 2, pp. 1207–14.
- Maršík, Martin, and Daniel Kopta. 2013. Use of the cluster analysis for assessment of economic situation of an enterprise. *Acta Universitatis Agriculturae et Silviculturae Mendelianae Brunensis* 46: 405–10. [CrossRef]
- Magyar Nemzeti Bank (MNB). 2019. *Long-Term Sustainable Econo-mix*. Budapest: Magyar Nemzeti Bank.
- OECD. 2016. *Effective Carbon Rates: Pricing CO2 through Taxes and Emissions Trading Systems*. Paris: OECD Publishing.
- OECD. 2019. Central and Eastern European Countries (CEECs). Available online: <https://stats.oecd.org/glossary/detail.asp?ID=303> (accessed on 10 December 2019).
- Pászto, Vít, and Jarmila Zimmermannová. 2019. Relation of economic and environmental indicators to the European Union Emission Trading System: a spatial analysis. *GeoScape* 13: 1–15. [CrossRef]
- Pereira, Alfredo M., and Rui M. Pereira. 2014. Environmental fiscal reform and fiscal consolidation: the quest for the third dividend in Portugal. *Public Finance Review* 42: 222–53. [CrossRef]
- Rozmahel, Petr, Luděk Kouba, Ladislava Grochová, and Nikola Najman. 2013. Integration of Central and Eastern European countries: Increasing EU heterogeneity. WWWforEurope Working Paper, No. 9, WWWforEurope—WelfareWealthWork, Wien. Available online: https://www.econstor.eu/bitstream/10419/125664/1/WWWforEurope_WPS_no009_MS77.pdf (accessed on 10 June 2020).
- Skaličková, Jolana. 2018. Shluková analýza regionů z pohledu lokalizace velkých podniků. *Logos Polytechnikos* 9: 124–38.
- Skovgaard, Jakob, Sofia Sacks Ferrari, and Åsa Knaggård. 2019. Mapping and clustering the adoption of carbon pricing policies: what polities price carbon and why? *Climate Policy* 19: 1173–85. [CrossRef]
- Soetewey, Antoine. 2020. The Complete Guide to Clustering Analysis: k-means and Hierarchical Clustering by Hand and in R. Available online: <https://www.statsandr.com/blog/clustering-analysis-k-means-and-hierarchical-clustering-by-hand-and-in-r/> (accessed on 13 November 2020).
- Solaymani, Saeed. 2017. Carbon and energy taxes in a small and open country. *Global Journal of Environmental Science and Management* 3: 51–62.
- Stuhlmacher, Michelle, Sanjay Patnaik, Dmitry Streletskiy, and Kelsey Taylor. 2019. Cap-and-trade and emissions clustering: A spatial-temporal analysis of the European Union Emissions Trading Scheme. *Journal of Environmental Management* 249: 109352. [CrossRef] [PubMed]
- Theodoridis, Sergios, and Konstantinos Koutroumbas. 2006. *Pattern Recognition*, 3rd ed. Cambridge: Academic Press, 856p.
- Van Heerden, Jan, James Blignaut, Heinrich Bohlmann, Anton Cartwright, Nicci Diederichs, and Myles Mander. 2016. The economic and environmental effects of a carbon tax in South Africa: A dynamic CGE modelling approach. *South African Journal of Economic and Management Sciences* 19: 714–32. [CrossRef]
- Ward, Joe. H. 1963. Hierarchical Grouping to Optimize an Objective Function. *Journal of the American Statistical Association* 58: 236–44. [CrossRef]
- Xiangmei, Xue, and Xu Yang. 2018. Temporal and Spatial Distribution Characteristics of Air Pollution Index (API) and its Correlation with the Improvement of Environmental Tax Law. *Journal of Environmental Protection and Ecology* 19: 471–76.
- Zaharia, Marian, Aurelia Pătrașcu, Manuela Rodica Gogonea, Ana Tănăsescu, and Constanta Popescu. 2017. A Cluster Design on the Influence of Energy Taxation in Shaping the New EU-28. *Economic Paradigm. Energies* 10: 257. [CrossRef]

Publisher's Note: MDPI stays neutral with regard to jurisdictional claims in published maps and institutional affiliations.



© 2020 by the authors. Licensee MDPI, Basel, Switzerland. This article is an open access article distributed under the terms and conditions of the Creative Commons Attribution (CC BY) license (<http://creativecommons.org/licenses/by/4.0/>).

Article

New Evidence Using a Dynamic Panel Data Approach: Cereal Supply Response in Smallholder Agriculture in Ethiopia

Anbes Tenaye ^{1,2}

¹ School of Economics and Business, Norwegian University of Life Sciences, 1430 Ås, Norway; anbes2003@yahoo.com

² Department of Agricultural Economics, Hawassa University, Hawassa 05, Ethiopia

Received: 15 May 2020; Accepted: 24 July 2020; Published: 30 July 2020

Abstract: Increasing agricultural production is essential to improving food availability and farm household incomes in developing economies. This study investigated the dynamic supply responses of major cereal crops to price and nonprice factors in Ethiopia using the Ethiopian Rural Household Survey (ERHS) panel dataset from 1994 to 2009. According to the Nerlovian expectation and adjustment approach in conjunction with the system GMM (generalized method of moments) estimator, both the planted areas and produced yields of major crops (*teff*, wheat, and barley) are influenced by price and nonprice factors in Ethiopia. The supply of major cereal crops is affected positively by their own prices and negatively by the prices of substitute crops. Nonprice factors such as education, farm size, fertilizer, land quality, and precipitation also affect supply of major cereals. Both the short-term and long-term acreage and yield response elasticities of *teff* and barley are positive. Moreover, the adjustment coefficients are positive for *teff*, barley, and wheat. The results suggest that Ethiopian farmers are capable of analyzing market signals and responding positively to price increases of staple crops. The findings also imply that the Ethiopian agricultural sector has been responsive to the cereal price increases observed since 2006. The remarkable growth of Ethiopian agriculture over recent decades is partly explained by the increase in agricultural prices. This study recommends that a fine-tuned balance between government interventions and market solutions is important, in addition to improving farmers' agronomic practices, for increasing agricultural production.

Keywords: system GMM; acreage response; yield response; supply elasticity; dynamic panel data approach; major cereals; Ethiopia

JEL Classification: D13; Q12; Q18

1. Introduction

Increasing agricultural production is indispensable for improving food availability and household incomes in Ethiopia. The Ethiopian economy has experienced notable transformations and challenges to sustained agricultural growth over the past few decades. Over coming decades, the development of the Ethiopian agricultural sector will continue to be challenged by rapid population growth, high economic activity, and urbanization, which lead to increasing food demands. The Ethiopian agriculture sector contributes 33.3% of the gross domestic product (GDP) (National Bank of Ethiopia 2019), 80% of occupations, 70% of the input for industry, 85% of food supplies, and 81% of foreign income to the country (African Development Bank Group 2016). However, the sector is dominated by subsistence peasant farming, with a marketed surplus of less than 20%. It is largely rain-fed, with less than 5% of the land irrigated (Central Statistical Agency 2014). Consequently, the agricultural output is tremendously vulnerable to weather conditions, in particular, the amount and distribution of rainfall.

Moreover, the Ethiopian agriculture sector contribution to GDP has declined from 41.1% in 2013/14 to 33.3% in 2017/2018 (National Bank of Ethiopia 2019). Under all of these challenges, the agricultural sector is considered to be one of the major sectors in addition to service and industry driving growth. Ethiopia seeks to develop into a middle-income country by 2025 (World Bank 2018). These factors call for sustainable development of the agricultural sector in Ethiopia. It is also vital to transform the primary sector to achieve higher productivity and a shift to higher-value products and services.

Recent projections show that there is rising food demand that calls for a significant increase in the availability of staple crops such as cereals, tubers and roots, and pulses (OECD and Food and Agriculture Organization of the United Nations 2016). Among other factors, weak or absent supply responses to market signals by smallholder farmers are vital (Anderson and Masters 2007; Di Marcantonio et al. 2014).

Cereals have received particular deliberation because of their large shares in the diets of most developing countries such as Ethiopia. In Ethiopia, more specifically, the three major cereal crops are *teff*, wheat, and barley. These crops are individually and jointly important in terms of area coverage, production, and consumption. For example, in July 2006–September 2008, *teff*, wheat, and barley represented 28%, 17%, and 11%, respectively, of the sown area in the country (Central Statistical Agency 2014). Moreover, the five major cereal crops (*teff*, wheat, maize, sorghum, and barley) are the hub of Ethiopia's agriculture and food sources, accounting for approximately 75% of the total area cultivated, 29% of the agricultural GDP in 2005/06 (14% of total GDP), and 64% of the calories consumed (Taffesse et al. 2012). Even though considerable growth in cereals in terms of the area cultivated, yields, and production has been recorded since 2000, the yields are low by international standards (Taffesse et al. 2012). Furthermore, increased cereal production and, in particular, sustainable agriculture are generally considered the most important issues of the 2030 agenda contributing to food security and thereby eliminating hunger (Talukder and Blay-Palmer 2017). Hence, cereal production plays a key role in the sustainable development of the Ethiopian agricultural sector.

The food price crisis of 2007–2008 and the recent resurgence of food prices have drawn growing attention to the causes and consequences of food price volatility in the developing world, particularly in sub-Saharan Africa (Headey 2016; Magrini et al. 2017, 2018; Minot 2014; Nakelse et al. 2018). Studies have indicated that staple food prices in sub-Saharan Africa have increased rapidly since 2006, even in US dollar terms (Headey 2016; Magrini et al. 2017; Magrini et al. 2018; Minot 2010). Ethiopia experienced an unprecedented increase in inflation that was among the highest in Africa during the global food crisis (Durevall et al. 2013). In the short term, agricultural supply shocks can affect food inflation, causing large deviations from long-term price trends (Durevall et al. 2013). Food prices increased over 150% in Ethiopia during 2007–2008, which was a period associated with a surge in global agricultural commodity prices (Minot 2010). Domestic prices of wheat and maize surpassed the import parity price in 2008 by as much as USD300 per ton (Rashid 2010). The nominal prices of *teff* and wheat rose gradually over the period of 2005–2007 before more than doubling between mid-2007 and mid-2008 (Rashid 2010). At the same time, the global prices of maize, wheat, and soybeans more than doubled, while global rice prices tripled between January 2006 and early 2008 (Minot 2010). However, the food price increases in Ethiopia were larger than the increases in the world markets for the same commodities (Minot 2010).

Previous food price increases in Ethiopia were different from those in many other developing countries (Rashid 2010). The domestic price increase in Ethiopia was not related to the global price increase, unlike in other countries. Instead, the price increase began with rapid growth in the money supply relative to the overall economic growth. This trend was later aggravated by a large negative balance of payments that resulted in government rationing of foreign exchange and increases in fuel prices.

High and unstable food prices are one of the major policy concerns in Ethiopia (Rashid 2010; Worako 2012). Accordingly, the government has responded with various policies, such as banning certain grains from export, and tariff reductions on imported foods, to lower the domestic prices.

However, these policies hinder local farmers from getting a better price and reduce biodiversity. The policy actions reflect the concerns of the government regarding the impact of food price increases on the poor, who spend an average of 54% of their household income on food (World Bank 2013). Increased food prices adversely affect urban consumers and net buyers, at least in the short term. However, the increase in food prices is an opportunity and incentive for agricultural producers, particularly net sellers, who experience structural and functional challenges in increasing production and productivity. It is widely acknowledged that increased agricultural prices create incentives for farmers to increase production through the increased use of inputs and the adoption of new technologies (Ampadu-Ameyaw and Awunyo-Vitor 2014; Bellemare et al. 2013; Magrini et al. 2017; Sadoulet and Janvry 1995; Thiele 2003). Additionally, farm production and productivity could be increased via technological progress and scale efficiency changes (Tenaye 2020a), and by improving farmers' technical efficiency (Tenaye 2020b). Moreover, the response to increased prices also depends on structural factors, such as the nature of smallholders, the availability of technologies, and the functioning of input markets.

The supply responses of Ethiopian farmers have been studied by many scholars. These studies have used aggregate time-series data such as export supply responses for coffee (Alem 1996; Dercon and Ayalew 1995) and supply responses for food grains (Abebe 1998; Zerihun 1999). Studies have also used time-series data with an error-correction model (Alemu et al. 2003), applied the profit function approach (Abrar and Morrissey 2006; Abrar et al. 2004a, 2004b), and used panel data (Abrar and Morrissey 2006).

These empirical supply response studies can be criticized on four grounds: the approach used, the modeling technique applied, the estimation technique employed, and the type of data used. First, the majority of studies applied the supply function approach, which is derived from the profit-maximizing framework (Abrar and Morrissey 2006; Abrar et al. 2004a, 2004b). This approach encompasses a combined estimation of the output supply and input demand functions (Mythili 2012). Thus, the supply function approach uses information regarding input prices and quantities, which are not readily available in less-competitive input markets. Second, most empirical studies overlooked the dynamic nature of supply responses. The estimation of the Nerlovian expectation model without accounting for the dynamic nature of the supply response function is likely to produce a biased result due to the correlation of the lagged dependent variable with the unobserved individual effects (Nickell 1981). Third, most studies used ordinary least squares (OLS) estimation (Abrar et al. 2004a) and maximum likelihood estimation (Abrar and Morrissey 2006; Abrar et al. 2004b). A possible correlation between the lagged dependent variables and the error terms likely produces biased results in a panel setting if OLS estimation is used (Baltagi 2008). Fourth, many studies used time-series data that fail to show the panel nature of the supply response. However, panel data have a distinct advantage in controlling household and temporal variations for dynamic models. Some past studies used a small number of observations to estimate the supply response. These concerns may have implications for the validity of the studies.

The main objectives of this study were to estimate the acreage and yield responses to price and nonprice factors and to estimate short-term and long-term elasticities of the three major cereals in Ethiopia. This study also aims to address the aforementioned concerns by using an extended Nerlovian model (Askari and Cummings 1977; Nerlove 1956), making use of the dynamic nature of supply response, the system generalized method of moments (GMM) estimator, panel data, additional relevant variables, and a relatively larger number of observations.

The remainder of the article is organized as follows. The second section introduces the methodology. The third section describes the results and discussion. The last section describes the major findings and policy implications.

2. Methodology

This section provides a brief overview of the data, the theoretical framework, the Nerlovian supply response model, and the estimation strategy.

2.1. Data Compilation

The data used in this study were obtained from the Ethiopia Rural Household Survey (ERHS). The ERHS is a unique longitudinal dataset covering rural Ethiopia. Addis Ababa University (AAU), the Centre for the Study of Africa Economics (CSAE) at Oxford, and the International Food Policy Research Institute (IFPRI) collaboratively collected the data for these rounds. Household panel data were collected in 1994, 1999, 2004, and 2009 from four major regions: Amhara; Oromiya; Southern Nations, Nationalities, and Peoples (SNNP); and Tigray. Each of these four regions is one of the nine administrative regions in the country, and together, they account for approximately 86% of the Ethiopian population. This survey covers 15 of the 389 woredas¹ (districts) and 18 farmers associations (FAs). The data were compiled into 1323 households producing the major cereals and 3170 observations. One FA was selected from each of the woredas². The surveys were conducted on a stratified sample over the country's three major agricultural farming systems that are found in five agroecological zones (Dercon and Hoddinott 2004). The first agroecological zone is known as the northern highlands. This zone includes two villages in the Tigray region, Geblen and Harresaw, and one from the Amhara region, Shumsheha. The northern highlands are characterized by poor resource endowments, adverse climatic conditions, and frequent droughts. The central highlands agroecological zone is represented by the villages of Dinki, Yetmen, and Debre Birhan, which are located in the Amhara region, and Turufe Ketchema in the Oromiya region. The Arussi/Bale agroecological zone includes the villages of Koro Degaga and Sirbana Godeti, which are both in Oromiya. Adele Keke is the sole survey site found in the Hararghe agroecological zone of Oromiya. The remaining five villages of Imdibir, Aze Deboa, Gara Godo, Adado, and Doma are found in the *enset*-growing agroecological zone located in the SNNP region. Sole cropping is the most common agricultural practice in the study areas, followed by mixed cropping. The panel dataset is organized based on four survey rounds conducted in the areas described above. Total rainfall data (in mm) from the National Meteorological Service Agency of Ethiopia (NMSAE 2014) are included in the Nerlovian output supply function.

The values of outputs are calculated based on the yields and prices of the sample crops. Because most variables are measured in local units, all local measurement units were converted to a common standard unit. This process enables us to aggregate and compare farm outputs and inputs within and between households. All value measures are expressed based on the 1994 prices using the producer price index for farm products and some of the inputs.

Table 1 provides descriptive statistics of the major variables of interest. Land is the basic asset of farmers in Ethiopia. The mean farm size is approximately 1.5 ha per household, with 0.01 ha and 11.5 ha being the minimum and maximum sizes, respectively. The soil fertility of the plots is medium on average, and approximately 47% of the farms have "good" soil fertility. Another indicator of soil fertility is the land quality index³, which takes the soil fertility and slope into account. On average, farms have a land quality index of 6.49, with a minimum of 1 and a maximum of 9. Approximately 75% of rural households operated on 2 ha of land or less, 50% cultivated farms operated on less than 1.2 ha,

¹ A woreda is a governmental administrative unit below zones in a given region and is equivalent to the designation of a district elsewhere.

² The Debre Birhan woreda in the Amhara region is large and includes four FAs that were included in the sample.

³ The average land quality index is calculated as a product of the natural conditions of two indices that assign a value of 3 if the slope is flat and a value of 3 if the land is fertile in terms of mineral content. A high index value indicates better soil fertility. The average land quality is best in terms of slope and mineral content when given a value of 9, with a value of 1 indicating the lowest land quality evaluated at the household level.

and 25% operated on land totaling 0.5 ha or less during the 1994–2009 cropping seasons. The average number of plots per household was 5. Thus, the farmers have immensely fragmented cultivated land.

Table 1. Descriptive statistics of variables in agricultural production.

Variable Code	Description	% With a Value of 1	Mean \pm SD
Sex	1 if the household head is male and 0 otherwise	79.87	
Family size	Total number of family members		6.80 \pm 3.04
Age	Age of the household head (years)		49.74 \pm 15.39
Education	1 if the household head is literate and 0 otherwise	37.57	
Farm size	Total farm size operated by the household (hectares)		1.51 \pm 1.18
Soil fertility	1 if the fertility status is good and 0 otherwise	47.08	
Labor	Adult equivalent unit (AEU)		4.07 \pm 2.22
TLU	Tropical livestock unit owned (TLU)		3.42 \pm 4.04
Fertilizer	Total real value of fertilizer expenditure of the household (Birr)		145.33 \pm 238.35
Credit	Total real value of credit taken by the household (Birr)	52.49	
Extension	1 if the household is visited by an extension agent for technical support and 0 otherwise	50.40	
Hoe	The number of a hoe(s) owned by the household		1.26 \pm 1.56
AEZ	Agroecological zone: 1 if the AEZ is the northern highlands, 2 for the <i>enset</i> -growing area (hoe farming), 3 for Hararghe (oxen farming), 4 for Arussi/Bale and 5 for the central highlands	14,33,8,13,32	
Precipitation	Rainfall amount (mm)		85.64 \pm 28.51
Land quality	Land quality index		6.49 \pm 2.29
Output value	Sum of the real values of crops and livestock (Birr)		3121.46 \pm 4211.12

Source: authors' calculations. SD = standard deviation. Notes: Monetary values are expressed in 1994 prices using the producer price index. Birr is the Ethiopian currency: 1 USD = 5.22 birr in 1994, 1 USD = 7.81 birr in 1999, 1 USD = 8.34 birr in 2004 and 1 USD = 11.53 birr in 2009 when the data were collected (National Bank of Ethiopia 2015). Subscripts for household number (i) and year (t) are omitted to improve readability.

Education plays an important role in the enhancement of the utilization of farm inputs and affects the willingness to adopt new technologies. However, only approximately 38% of household heads have attended some schooling that enables them to read and write. This finding shows that the level of education in the study area is extremely low.

Water from either rainfall or irrigation is one of the most important inputs for agricultural production but is rarely considered as an input in Ethiopian agriculture. However, rain-fed agriculture dominates Ethiopian farming, while only approximately 4 to 5% of potentially irrigable land is irrigated (Awlachev et al. 2010). The rainfall amount and distribution are also important factors in agricultural production, although only the amount is used in this analysis. Rainfall is expected to have a positive effect on the yield supply response because the crops studied are rain-fed. Other related factors, such as the soil fertility, labor, extension, hoe and fertilizer, and the water-retaining capacity of the soil, also affect production. Information on some of these attributes would be useful for explaining the impact on the output supply.

2.2. Theoretical Framework

A fundamental principle of economics is the theory of supply, which states that producers produce more quantity as a result of an increase in the price when other factors are kept constant. In other words, smallholder farmers are encouraged to produce more of the product if they would expect a higher price, as indicated by the “producer theory”. Supply analysis is one of the commonly used techniques in the literature that evaluates production responses to prices (output and input prices) and nonprice factors (such as policy, environment, and household characteristics). The theory of the firm is the basis from which supply analysis is derived (Colman 1983). This production process can be assessed using production, cost, distance, or profit functions.

Supply analysis can be studied using two main approaches: normative (programming) and positive (econometric). The positive approach has two subgroups: primal (structural) and dual (reduced) approaches (Colman 1983; Sadoulet and Janvry 1995). The primal approach involves estimation of the structural production function or stochastic frontier (Coelli et al. 2005), whereas the dual approach involves estimation of the cost or profit functions.

The agricultural supply is typically modeled as the response of the crop-sown area (or yield produced) as a function of price and nonprice factors (Askari and Cummings 1977). The three price-expectation models commonly used in the literature to study supply responses are the naïve price-expectation model, the adaptive price-expectation model, and the rational price-expectation model. These models vary primarily in their assumptions of how farmers structure their price expectations (Haile et al. 2015). The naïve price-expectation model assumes that farmers do not have a learning process in structuring their price expectations and, instead, they make their crop area decisions exclusively based on the market price realized in the earlier period (Ezekiel 1938). The adaptive price-expectation model allows farmers' crop area allocation decisions to be responsive to the expected price and the prices realized in all earlier periods (Nerlove 1956). The rational price-expectation model assumes that farmers adjust their price expectations based on all available information in the market (Askari and Cummings 1977; Muth 1961). Rational price-expectation relationships may not be straightforward, as they are determined by both supply and demand equations, which require extra data (Nerlove 1979).

The Nerlovian supply response model (the Nerlovian adaptive expectation and the partial-adjustment model) is the most commonly used (Askari and Cummings 1977; Khan et al. 2019; Magrini et al. 2018; Ogundari 2018; Shonkwiler and Hinckley 1985; Wickens and Greenfield 1973; Zhai et al. 2019).

2.3. The Nerlovian Supply Response Model

Following the most common approach in previous studies, this study also employs a Nerlovian framework to investigate how the supplies of major cereal crops in Ethiopia respond to price and nonprice factors. The Nerlovian partial-adjustment model specifies the outcome variable of interest (sown area and produced yield of the major cereal crops in this study) as a function of the expected output price, sown-area adjustment, and a set of nonprice variables. All continuous variables are converted to logarithms and thus coefficients can be interpreted as elasticities. The commonly adopted Nerlovian model consists of three "structural" equations (Askari and Cummings 1977; Nerlove 1979):

$$A_t^d = \alpha_0 + \alpha_1 P_t^e + \alpha_2 Z_t + v_t \quad (1)$$

$$P_t^e - P_{t-1}^e = \beta(P_{t-1} - P_{t-1}^e), 0 \leq \beta \leq 1 \quad (2)$$

$$A_t - A_{t-1} = \gamma(A_t^d - A_{t-1}), 0 \leq \gamma \leq 1 \quad (3)$$

where A_t^d is the desired cultivated area (can be yield) in period t ; P_t^e is the expected prices of the crop and other competing crops for period t ; Z_t is a set of other exogenous shifters, such as rainfall, land quality, fertilizer, farm size, education; v_t accounts for unobserved random factors affecting the area being planted with a specific crop; α_i is the parameter to be estimated; P_{t-1} is the lagged price that prevails when decision making for production in period t occurs; β is the adaptive-expectation coefficient; A_t is the actual area planted with a specific crop; and γ is the partial-adjustment coefficient. The desired cultivated area of a specific crop c for individual household i during period t is a function of the expected output prices and many other exogenous factors. Similarly, the desired output of a certain crop c for individual household i during period t is a function of the expected output prices and many other exogenous factors (Braulke 1982; Diebold and Lamb 1997). Either the harvested tonnage or planted acreage could be used as the output variable (Bond 1983).

The price that the producer expects to receive at harvest time cannot be observed. Therefore, one must specify a model that explains how agents form expectations based on actual and past prices, as well as other observable variables. For example, farmers adjust their expectations as a fraction of the deviation between their expected price and the actual price in the last period, $t - 1$, via Equation (2). Because a full adjustment to the desired allocation of land may not be possible in the short term, the actual adjustment in the area is only a fraction γ of the desired adjustment in Equation (3). Further details on the derivation of equations can be found in Appendix A.

2.4. Estimation Strategy

There are two common approaches for estimating a supply response in the economics literature⁴. The first approach is the Nerlovian expectation model, which is used to analyze both the rate and level of adjustment of the actual acreage. This acreage adjustment is made based on the expected yield. The second is the supply function approach, which is derived from the profit-maximizing framework. This approach encompasses the combined estimation of the output supply and input demand functions. The supply function approach requires information on all of the input prices and quantities, which were not readily available for the current study. Moreover, the agricultural input markets in Ethiopia, such as land and labor, neither exist nor function in a competitive market. Thus, I use the Nerlovian expectation model to estimate the supply response to the increase in output prices and nonprice factors over the study period. Just (1993) and Sadoulet and Janvry (1995) review these approaches. They conclude that the Nerlovian approaches are well suited to handle these dynamic processes in the supply response.

The pioneering work of Nerlove (1958) on supply responses also enables us to determine short-term and long-term elasticities. The Nerlovian model offers flexibility when introducing nonprice shift variables into the model. Production decisions must be based on the prices that farmers expect to receive during the harvest period after several months. Nerlovian models are built to examine farmers' output reactions based on price expectations and partial area adjustments (Nerlove 1958). The crop supply response models can be framed in terms of yield and/or area responses. For instance, the desired crop area to be planted in period t is a function of the expected output prices P_e and a vector of exogenous variables Z (Braulke 1982; Diebold and Lamb 1997).

This study used a Nerlove-type model to specify the production responses to output price changes. Equations (4) and (5) are the reduced form of the Nerlovian model. These equations describe the current level to which the area (or yield) is determined by the previously expected level of prices, a set of nonprice variables, the past level of the area (or yield), and the disturbance term. Equations (4) and (5) present the theoretical description of the Nerlovian model, and their final form used for empirical estimation must capture the relevant factors underlying the agricultural supply. Hence, introducing these factors into the agricultural supply function equations (acreage (4) and tonnage (5)) could allow them to be rewritten as Equations (4) and (5), respectively.

$$A_{cit} = a_0 + a_1 P_{cit-1} + a_2 Z_{cit} + a_3 A_{cit-1} + u_{cit} \quad (4)$$

$$Y_{cit} = a_0 + a_1 P_{cit-1} + a_2 Z_{cit} + a_3 Y_{cit-1} + u_{cit} \quad (5)$$

where,

A_{cit} = area of the crop c at time t for household i

⁴ The agricultural household model is another choice for characterizing the complexity of household supply behaviors in response to price incentives (Singh et al. 1986). This alternative approach requires information on household consumption, input prices, and the input quantities used for each crop (e.g., labor). The Nerlovian expectation model is used here because the primary concern of this study is to estimate the production response to the output price incentive and nonprice factors rather than the overall behavioral responses.

P_{cit-t} = current price and price lagged by one period for the crop c for household i

Z_{cit} = other exogenous variables (such as the total farm size, average rainfall, land quality, education, prices of other crops, and crop dummies)

A_{cit-1} = area lagged by one period for the crop c for household i

t = production year under consideration

u_{cit} = error term of the crop c at time t for household i .

Similarly,

Y_{cit} = output of the crop c at time t for household i

P_{cit-t} = current price and price lagged by one period for the crop c for household i

Z_{cit} = other exogenous shifters (such as the area of the crop, average rainfall, land quality, education, prices of other crops, and crop dummies)

Y_{cit-1} = output lagged by one period for the crop c for household i

t = production year under consideration

u_{cit} = error term of the crop c at time t for household i .

To capture the full supply response, therefore, both yield response models with the acreage response (A_t), and yield (Y_t) are estimated using Equations (4) and (5), respectively. The area response model is influenced by one additional regressor (total farm size), in contrast to the yield response model, which is also influenced by one additional regressor (area of the crop). Education is an important yield-augmenting input, in addition to rainfall. The area and yield response models give us short- and long-term area and yield elasticities, respectively. Adding the area and yield elasticities yields the supply elasticities.

The reduced form is a distributed lag model with lagged dependent variables taken as independent variables. The coefficient of each explanatory variable gives short-term elasticities, and the long-term elasticities are obtained by dividing the short-term elasticities by $(1 - a_3)$ (i.e., the adjustment coefficient), where a_3 denotes the coefficients of the lagged dependent variables (Mythili 2012; Sadoulet and Janvry 1995). The assumption underlying this model is that all long-term elasticities exceed the short-term elasticities. If the adjustment coefficient is close to 1, this implies that the farmers' adjustment of the actual acreage to the desired acreage occurs quickly. If the adjustment coefficient is close to zero, then the adjustment occurs slowly. The prices are revised in each period in proportion to the difference between the last period's observed price and the previous period's expectation. p_t^e is the average price expected to prevail in all future periods. The farmer responds rationally based on the average "normal" price level rather than the price forecast.

Modeling the supply response is a two-stage procedure. First, farmers allocate plots to crops based on expected prices. Second, the yield is determined based on the plot area, other inputs, and weather conditions. Generally, farmers revise the use of other inputs after they allocate a specific crop to a plot, and the overall input changes will be reflected in the yield. Thus, it is realistic to assume that both the area planted and the yield produced can be used as proper dependent variables to study farmers' responses to output prices and nonprice factors. However, the yield harvested is subject to greater fluctuation than is the area planted because of uncertain random factors, such as the temperature, rainfall, input use, and management. To understand the farmers' behaviors in crop allocation choices, the area response is more appropriate than the yield response for measuring the supply response.

Overall, the Nerlovian framework is preferred over other models for analyzing producer behaviors in developing countries for at least three reasons. The first is that the left-hand-side variable is dynamic. The second is that it enables the computation of short-term and long-term responses and the speed of adjustment in moving from the actual to the desired level of area and yield. The third is that the alternative model requires detailed data on input prices and quantities, which are difficult to obtain for developing countries due to market failures.

Both the acreage and yield Equations (4) and (5) represent dynamic panel models, whereby the dependent variable is a function of its lagged values, among other factors. Applying an OLS or

fixed effects (FE) estimation for a dynamic panel model leads to a dynamic panel bias due to the correlation of the lagged dependent variable with the unobserved individual effects (Nickell 1981). In this case, therefore, the difference GMM and system GMM are two closely related dynamic panel data model estimators that were first developed by Holtz-Eakin et al. (1988). Arellano and Bond (1991) developed a difference GMM estimator, also called the “Arellano–Bond” estimator, to estimate a dynamic panel model by differencing and using lagged endogenous and other exogenous variables as instruments (Roodman 2009). Arellano and Bover (1995) and Blundell and Bond (1998) further developed the Arellano–Bond/Arellano–Bover estimation methods into a method collectively known as the system GMM. The system GMM technique transforms the instruments themselves to make them exogenous to the fixed effects (Roodman 2009). The system GMM estimator allows efficiency gains over the differenced GMM estimator, provided that the initial differences of the instrument variables are uncorrelated with the fixed effects (Blundell and Bond 1998).

In general, the system GMM estimation method is suitable for data with few periods and many unit (small T and large N) panels, lagged dependent variables, fixed effects, heteroscedastic variance, autocorrelated errors, and endogenous regressors (Roodman 2009). The chosen variables are believed to be good predictors of planned supplies of *teff*, wheat, and barley. Both price and nonprice factors such as the real producer prices of their own and substitute crops, rainfall, farm size, land quality, and education are included. Empirical evidence shows that the dynamics of supply can be better estimated using system GMM (Blundell and Bond 1998; Brockhaus et al. 2015; Roodman 2009). System GMM does not assume normality and controls for heteroscedasticity, unlike the conventional OLS method (Jaunky 2013). The Nerlovian model, which addresses the analysis of both the rate and the level of adjustment of the actual acreage towards the desired acreage, does not require input prices or quantities. These estimators are appropriate for the current study because the left-hand variables of Equations (4) and (5) are dynamic, and the data have a short panel. These estimators also separate the fixed effects from idiosyncratic errors that are heteroscedastic and correlated. Autocorrelation, heteroscedasticity, and contemporaneous correlation cause estimation problems in panel observation. Furthermore, this method enables the introduction of variables as strictly exogenous, predetermined, or endogenous (Roodman 2009). In this study, the lagged dependent variables (area and yield) and the price variables (the crop prices) treated as predetermined variables. Hence, the GMM estimation generates the internal instruments (instrument variables) via data-generating processes (i.e., orthogonal deviations) and lags of the price of *teff*, barley, wheat, and the area of the crop. The other exogenous instruments are precipitation, lagged precipitation, and time dummy. Thus, the possible endogeneity of variables in my models is controlled.

In Equations (4) and (5), the areas allocated to a specific crop and yield produced, respectively, are treated as endogenous variables, assuming that these variables are endogenous to prices, rainfall, the total farm size owned by the household (in the case of the area response), the area allocated to a specific crop (in the case of tonnage response), the land quality, and education. In both equations, contemporaneous rainfall enters all of the models as a strictly exogenous variable. Thus, I use the system GMM method to estimate the dynamic supply models, as implemented in the STATA 13[®] module *xtabond2* (StataCorp 2013), which is used to estimate Equations (4) and (5) for acreage and yield responses of three major cereals.

3. Results and Discussion

This section provides the trends of price, area, and the output of major cereals, and the estimation results of the Nerlovian adaptive-expectation and partial-adjustment models using a dynamic panel data approach and system GMM estimation techniques.

3.1. The Trends of Price, Area, and Output of Major Cereals in Ethiopia from 1994 to 2009

The figures depict the trends of the price in birr per kg (Figure 1), area in ha (Figure 2), and output in birr (Figure 3) of major cereals in Ethiopia from 1994 to 2009. As shown in Figure 1, the prices of

major crops began to increase as early as 2004, with the sharpest increase occurring in the years 2006 to 2008.

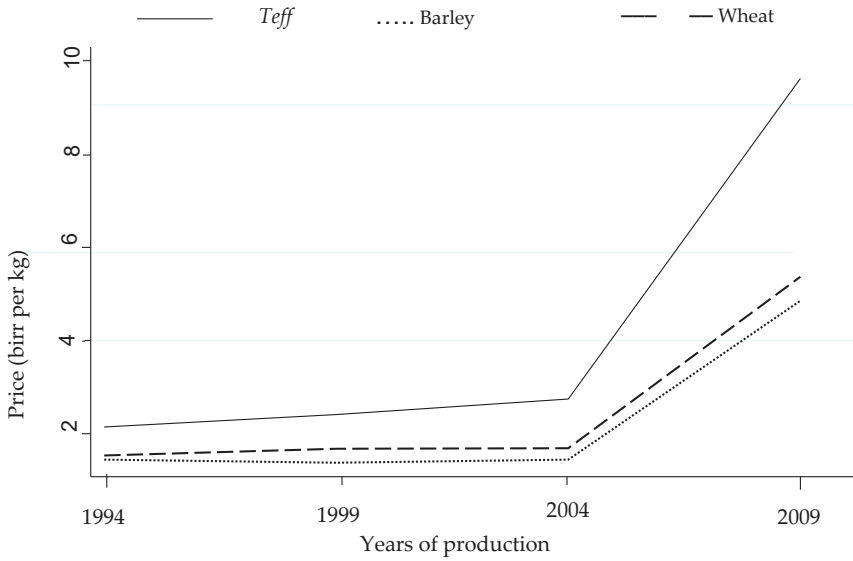

Figure 1. Price trends of major crops in Ethiopia (1994–2009).

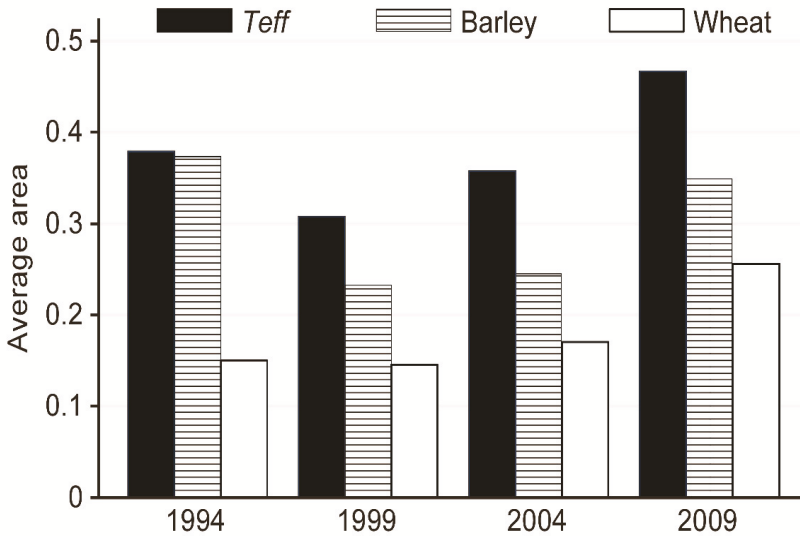

Figure 2. Average area (ha) cultivated for major cereal⁵ crops in Ethiopia (1994–2009).

⁵ Cereals are annual crops, while most cash crops are perennial crops. Cereals need one season until harvest and live for only one season during each year. Perennial crops require two or more seasons until the first harvest, after which they can be harvested for several years until they expire. For example, *Coffea Arabica*, which is known as Arabica coffee, bears fruit after three to five years and produces fruit for approximately 50 to 60 years (for a maximum of 100 years). Chat plants yield the first harvest in 2 to 3 years. Chat harvesting can occur 2–3 times a year for 50 or more years. According to [Tenaye and Geta](#)

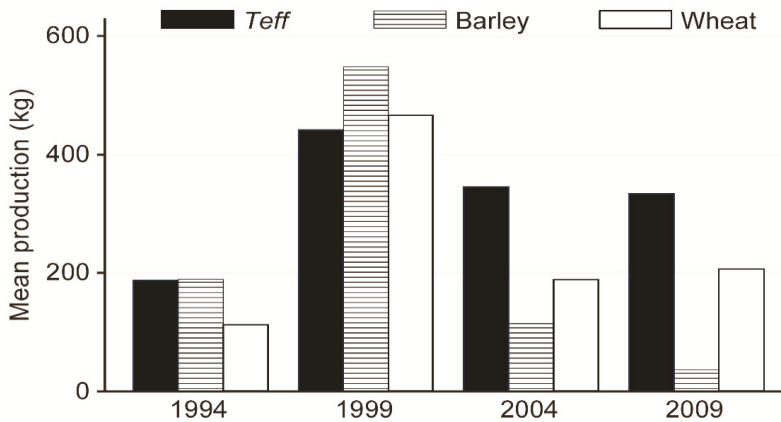

Figure 3. Average production (kg) of major crops in Ethiopia (1994–2009).

Teff is a staple food for more than 110 million of the country's people. *Teff* is typically banned from export as part of the food price stabilization measures taken by the government in Ethiopia. Other cereals are rarely exported because they are neither competitive nor provide a sufficient surplus for export. On the contrary, wheat is imported for more than 15% of the country's production annually.

Households decide which crops to plant based on the price expected for the crops and the availability of other crops and vegetables for their consumption, among other factors. The area allocated to *teff*, barley, and wheat evidently increased during the study period (Figure 2).

As shown in Figure 3, there are variations in the outputs of the major cereals over time. The yield variation depends on the input use, disease, weather conditions, management, and other factors. Farmers may shift the crop to a larger but marginal piece of land, and there may be an increase in the area but a decrease in the output when all other factors remain constant. This partly explains the inverse relationship between the area and the output.

Most Ethiopian farmers have limited financial resources, which limit the yield per hectare, as the use of fertilizers is quite low. Additionally, a considerable proportion of their harvest is sold immediately following harvest when prices are low. Early sales are conducted primarily to pay for fertilizer credit and to cover regular household expenses.

Recently, producer cooperatives have attempted to fill this financial gap for some specific cash crops in a few areas. For example, coffee producers in southern regions form coffee producer cooperatives that buy coffee from farmers at a reasonable price and sell it during a later period. The cooperatives redistribute profits to their member farmers based on the amount sold by the farmers.

3.2. Estimation Results of the Nerlovian Adaptive-Expectation and Partial-Adjustment Models

This study examined the extent to which the production of major cereal crops responds to price and nonprice factors in Ethiopia. Both acreage and yield responses to an increase in output prices and nonprice covariates were estimated using a panel database from Ethiopia. To check the validity of the preferred models and specifications, the Sargan test was employed for the overidentification restrictions, the Hansen test was used for the exogeneity of the instruments, and the Arellano–Bond test was applied for autocorrelations. Furthermore, robust standard error estimates were computed for the presence of

(2009), mature *enset* plants (4 to 7 years old) are harvested mainly to prepare staples known as *kocho* and *bulla*, whereas immature *enset* plants (less than 2 years old) are harvested to prepare *amicho*. All of these perennial crop areas require a long period to be converted to other crops and are much less flexible than annual crops in terms of shifting area coverage.

any pattern of heteroscedasticity and autocorrelation within the panels. Unobserved heterogeneity was also controlled using panel datasets. The difference-in-Hansen test reports the p -values for the validity of the additional moment restriction necessary for system GMM. The autocorrelation test reports the p -values for the first-order autocorrelation of the first-differenced residuals. The test results are provided at the bottom of Table 2. The null hypothesis that the population moment conditions are correct is not rejected; thus, the validity of the instruments is verified using the Hansen test. The other test statistic reported is the Arellano–Bond test for autocorrelation of all acreage and yield models, which looks at the second-order correlation to test for first-order serial correlation in levels of the error term. The F-test supports the overall fit of the dynamic model. All of these tests indicated the consistency of the system GMM estimators.

Table 2. Estimation results of the Nerlovian adaptive-expectation and partial-adjustment models for *teff*, barley, and wheat.

Variables	Area Response (in hectares (ha))			Yield Response (in Real Birr Value)		
	(1)	(2)	(3)	(4)	(5)	(6)
Lagged Dep. Variable (ha)	0.249 *** (0.079)	−0.099 (0.398)	0.244 * (0.144)	0.180 *** (0.067)	−0.542 *** (0.176)	−0.148 * (0.082)
Current <i>teff</i> price (real price per kg (birr))	−4.381 ** (2.165)	−7.701 (7.480)	6.566 * (3.950)	−19.463 *** (4.989)	14.524 ** (5.884)	19.434 ** (7.806)
Lagged <i>teff</i> price (real price per kg (birr))	5.460 *** (1.860)	12.774 * (6.834)	−4.098 (3.091)	11.386 *** (2.746)	−6.321 * (3.355)	−2.253 (5.608)
Current barley price (real price per kg (birr))	0.044 (0.284)	0.876 ** (0.422)	0.0289 (0.270)	−0.290 (0.312)	3.015 *** (0.290)	0.333 (0.355)
Lagged barley price (real price per kg (birr))	−0.055 (0.114)	0.443 ** (0.187)	0.16 (0.122)	0.236 ** (0.120)	1.083 *** (0.206)	0.361 *** (0.127)
Current wheat price (real price per kg (birr))	−0.158 (0.200)	−0.879 * (0.467)	−0.216 (0.168)	−1.300 *** (0.376)	−0.516 * (0.307)	0.827 *** (0.243)
Lagged wheat price (real price per kg (birr))	−0.0687 (0.069)	−0.455 ** (0.179)	−0.069 (0.116)	−0.225 * (0.128)	0.041 (0.189)	0.025 (0.192)
Farm size (ha)	−1.512 (3.056)	10.84 ** (4.975)	6.204 ** (3.136)			
Lagged farm size (ha)	−1.910 ** (0.943)	−7.780 ** (3.551)	1.1 (1.253)			
Area of the crop (ha)				0.248 (0.365)	−0.673 ** (0.264)	0.276 (0.604)
Lagged area of the crop (ha)				−0.071 (0.163)	0.611 ** (0.300)	0.941 *** (0.362)
Rainfall amount (mm)	2.755 *** (0.717)	5.037 (3.335)	−1.790 * (0.994)	−1.567 (1.209)	−0.442 (0.567)	−0.212 (1.237)
Land quality index	0.127 (0.238)	0.652 ** (0.304)	−0.155 (0.236)	1.371 *** (0.452)	−1.657 *** (0.264)	−2.200 *** (0.447)
Education dummy	1.335 (4.233)	10.79 (8.926)	6.334 (4.076)	18.473 *** (5.340)	−0.005 (1.975)	−10.345 ** (4.004)
Fertilizer (birr)						0.389 * (0.209)
<i>Teff</i> dummy		−10.39 ** (4.951)	3.033 (2.162)		2.660 (1.666)	13.388 *** (4.321)
Barley dummy	−0.500 (1.232)		0.391 (1.634)	2.775 (2.242)		−9.021 *** (1.903)

Table 2. Cont.

Variables	Area Response (in hectares (ha))			Yield Response (in Real Birr Value)		
	(1)	(2)	(3)	(4)	(5)	(6)
	Teff Area	Barley Area	Wheat Area	Teff Value	Barley Value	Wheat Value
Wheat dummy	2.642 * (1.506)	2.291 (5.559)		-1.122 (2.120)	1.121 (2.249)	
Time dummy (2006)	5.872 ** (2.779)	8.867 (9.588)	-9.403 * (5.015)	22.699 *** (5.912)	-28.035 *** (8.961)	-25.995 *** (9.719)
Constant	-17.47 *** (4.447)	-29.47 * (17.480)	-2.709 (5.948)			
Arellano-Bond test of AR(1) (<i>p</i> -value)	0.016	0.003	0.064	0.000	0.000	0.000
Sargan test of overid. restrictions (<i>p</i> -value)	0.096	0.353	0.204	0.515	0.161	0.151
Hansen test of overid. restrictions (<i>p</i> -value)	0.226	0.702	0.722	0.514	0.000	0.012
Hansen test of exogeneity of instruments (<i>p</i> -value)	0.266	0.691	0.196	0.689	0.461	0.006
Hansen test of exogeneity of instrument subsets (<i>p</i> -value)	0.219	0.567	0.939	0.247	0.000	0.631
F-test of overall model fitness (<i>p</i> -value)	0.000	0.000	0.000	0.000	0.000	0.000
Number of instruments	20	20	20	23	22	21
Number of households	1323	1323	1323	1323	1323	1323
Number of observations	3170	3170	3170	3170	3170	3170

Notes: all prices were deflated using producer price indices in 1994. The Sargan test of overidentification restriction is performed to verify whether the figures are “not robust but not weakened by many instruments”, whereas the Hansen test of overidentification restriction is performed to verify whether the figures are “robust” but weakened by many instruments. The Hansen test of exogeneity of instruments is reported with *p*-values. Coefficients are simultaneous two-step system GMM estimates, with the lagged dependent variable and the price variable treated as predetermined. Robust standard errors are in parentheses. The set of instruments includes the exogenous variables in vector Z. The difference-in-Hansen test reports the *p*-values for the validity of the additional moment restriction necessary for system GMM. The autocorrelation order one, AR(1), reports the *p*-values for the first-order autocorrelation of the first-differenced residuals. Stars *, **, and *** represent the 10%, 5%, and 1% levels of significance, respectively.

The major research questions of interest were how major cereal crop supplies respond to price and nonprice factors, how the different supply responses behave across cereals, and whether these cereal supplies responded to price changes before and after 2006. The empirical applications of the cobweb supply model, in which producers’ expectations regarding prices are assumed to be based on their observations of previous prices, are relevant to this analysis. An important point of departure in this study is that both the area and yield responses are measured. Table 2 reports the dynamic panel data estimator results for the area and yield responses.

Following the Nerlovian approach, I used area and yield responses to measure the supply responses to prices and nonprice factors. Based on my data, the area response appears to be a more reliable indicator of the supply response compared to the yield response for the reasons⁶ explained earlier. It is also implicit that the acreage responses underestimate the supply responses when farmers respond to price incentives partly through the intensive application of other inputs in a given area, which can be reflected in the yields. Therefore, the acreage and yield response functions were estimated separately and, subsequently, the supply response estimates were derived using these two responses. In this case, the supply responses better reflect farmers’ behaviors. Otherwise, the supply response could be biased to conceal some variations in the area and yield if they move in opposite directions.

⁶ The area decision is, to a large extent, under the control of the farmer, while the yield responses can be affected by the inputs used and the weather conditions, as evidenced by different tests (autoregressive, over-identification restrictions, exogeneity of instruments, and unobserved heterogeneity) and economic theories.

The estimated coefficients reported in Table 2 show the elasticity of the household-level crop area planted and yield produced. Yield responses are approximated by value. The results show that almost all variables of interest in the acreage equation are statistically significant for *teff*, wheat, and barley. The acreage responses of major crops are affected positively by their own prices for *teff* and barley, and negatively by the prices of substitute crop for barley (reported in columns 1, 2, and 3). On average, if the price of a staple food crop at the household level increases by 1%, the *teff* acreage rises by 5.46%, and the barley acreage increases by 0.443%. Similarly, there is also a significant yield response to the output price for the same crops. The yield response of major crops is affected positively by their own prices and negatively by the prices of substitute crops for *teff* and barley. If the price of a staple food crop at the household level increases on average by 1%, the *teff* yield rises by 11.386%, and the barley yield increases by 1.083%. The results of estimating the Nerlovian partial-adjustment model shed new light onto the supply dynamics of major cereal crops in Ethiopian agriculture. In particular, the estimated one-year lagged-area elasticity of these crops indicates a solid influence of farmers' previous allocation decisions on current decisions of *teff* and wheat, which is consistent with previous findings (Zhai et al. 2019). Considering these results, I can make the following points. First, Ethiopian farmers can interpret the market signals and respond positively to increases in the real prices of staple food crops, as suggested by economic theory. Second, the results show that farmers use price information not only to decide how much acreage to allocate to the crops but also to adjust their farming intensity throughout the cropping period. Finally, *teff*'s short-term price response coefficients are better in terms of magnitude, sign, and statistical significance than are the coefficients of barley and wheat for both area and yield responses. This is because *teff* is one of the major food crops consumed locally and demanded globally because of its use in gluten-free products. These findings are consistent with standard economic theory and intuition.

Additionally, in terms of the statistical significance of individual coefficients, the *teff* equation is consistent in terms of sign compared to the barley and wheat equations. The crop's own price plays an important role in acreage decisions for *teff* and barley in addition to nonprice factors. *Teff* can be consumed mainly alone or with wheat as a staple food. For wheat, production decision is positively influenced by its own price, unlike acreage decision. A significant volume of wheat is imported annually. Wheat is also consumed mainly in the form of bread. Barley is used to make homemade beer, which is locally known as *tela*, and as an input for local breweries. Thus, these crops are considered complements to or substitutes for one another. They also compete mainly for land and labor. There are significant supply responses to price increases of major crops in Ethiopia.

Moreover, the results identify potential competitor crops and complements of major cereal crops in Ethiopia. More specifically, *teff* is identified as a complementary crop of barley by the model, as the supply (sown area) of barley in response to the lagged price of *teff* is positive (and statistically significant), suggesting a complementary relationship between the sown area of barley and the *teff* price. Moreover, wheat is identified as a competitive crop of barley by the model, as the sown areas of barley in response to the price of wheat are negative and statistically significant, indicating a competitive relationship between the sown area of barley and the lagged wheat price. Meanwhile, the *teff* sown-area response is not influenced by the prices of any of these major cereal crops (barley and wheat). Similarly, in terms of yield, barley and wheat are identified as a complement and competitive crop of *teff* yield by the model, respectively. The produced yield of *teff* in response to the lagged price of barley and wheat is positive and negative, respectively, and statistically significant, indicating a complementary and competitive relationship between the produced yield of *teff* and the lagged barley and wheat prices, respectively. *Teff* is identified as a competitive crop of barley produced and statistically significant, indicating a competitive relationship between barley produced and the lagged price of *teff*, whereas barley is identified as a complementary crop of wheat by the model, indicating a complementary relationship between wheat produced and the lagged price of barley.

Furthermore, the results in Table 2 suggest that the impacts of nonprice factors, such as the total farm size, rainfall, land quality, fertilizer, and education, have somewhat mixed effects. For example,

rainfall has a positive effect on the *teff* area planted and a negative effect on the wheat area planted. The current-period *teff* and barley area allocations are affected negatively by the corresponding total farm sizes in the previous period. Meanwhile, the current-period barley and wheat area allocations are affected positively by the corresponding total farm size in the current period.

Finally, Table 2 reports that statistical tests concerning the differences between the pre- and post-price increase estimates provide few rejections of the equality of these estimates. The difference in statistical significance is shown in the area and yield responses of *teff* and wheat. There is clear evidence that the response of the *teff* area increased after the price increases, while the wheat area decreased. There is no clear evidence to support the notion that the response of the barley area increased significantly after the price increase. Similar patterns were observed in terms of yield responses for these crops. Among the yield responses, that of *teff* increased, while that of wheat and barley decreased after 2006.

Generally, area allocation among individual crops can be affected by other factors, including whether an individual farmer practices monoculture or intercropping, the farm size, the possibility of crop rotation vs. designating certain areas that are more suited to specific crops, and the proportion of area covered by perennial crops. Given all of these factors, farmers shift crops between areas based on the output price expectations and yields desired. Large farms have more space for shifting areas between crops than do small farms. Thus, the operators of small farms are likely to face more constraints on area shifting between crops in comparison to large farm operators.

3.3. Short-Term and Long-Term Elasticities and Adjustment Coefficients of Major Crops

As shown in Table 3, I find positive short- and long-term price elasticities for *teff* and barley. Table 3 reports that the acreage response elasticity of *teff* estimates is very high, ranging between 5.46 in the short term to 21.16 in the long term. In particular, a 1% increase in the *teff* price increases—on average—*teff* acreage by 5.46%, *teff* yield by 11.39%, and *teff* supply (sum of acreage and yield) by 16.85% in the short term. Similarly, a 1% increase in the *teff* price increases—on average—*teff* acreage by 7.27%, *teff* yield by 13.89%, and *teff* supply (sum of acreage and yield) by 21.16% in the long term. *Teff* is the most consumed cereal in the country, and is consumed in the form of injera (local pancake); furthermore, it is undergoing increasing international demand due to its use in gluten-free products. Both the short-term and long-term area and yield response elasticities of barley are positive. For barley, a 1% increase in price increases—on average—barley acreage by 0.44%, barley yield by 1.08%, and barley supply by 1.52% in the short term. Likewise, a 1% increase in the barley price increases—on average—barley acreage by 0.40%, barley yield by 0.70%, and barley supply by 1.10% in the long term. This is partly explained by the growing barley demand from breweries. In contrast, the wheat area response elasticities are negative and insignificant in both the short and long term. This is partly explained by the growing wheat import by the country. Considering both the area and yield estimated coefficients, this study supports the notion that farmers respond to increasing prices to some degree through the intensive application of other inputs, such as fertilizer, in addition to extending the area planted. As expected, the long-term elasticities with respect to the lagged real prices are higher than the short-term elasticities, which is indicative of the long-term adjustment of the areas and yields under the crops. This is due to various factors that are fixed in the short term, as well as structural constraints, and because some farmers respond when they feel more certain that price changes are stable.

The adjustment coefficient measures the speed and magnitude of change between the desired and actual area (yield). The adjustment coefficient is calculated by one minus the coefficient of the lagged dependent variable. They all are above average, i.e., $\gamma > 0.5$, indicating that the adjustment speed is higher. As shown in Table 3, the adjustment coefficient for the *teff* area is $1 - 0.25 (= 0.75)$, which is close to one, indicating that farmers adjust rapidly towards the desired *teff* acreage. Additionally, the adjustment coefficients for the barley and wheat areas are 1.10 and 0.76, respectively. Thus, barley and wheat producers adjust towards the desired area relatively more rapidly than do those producing *teff*. The supply response to the price is larger in the case of *teff*, which is a “major” food

crop in Ethiopia. This difference might be because *teff* production is mainly conducted for market consumption, whereas barley and wheat are mainly grown for home consumption in most of the study areas. A higher proportion of *teff* produced is traded compared to barley and wheat. This is partly due to *teff* becoming a famous food grain globally because of its use in gluten-free products. The increase in *teff* demand has contributed to an increase in *teff* acreage.

Table 3. Short-term and long-term elasticities with respect to real output prices and partial-adjustment coefficients of major crops.

Particulars	<i>Teff</i>			Barley			Wheat		
	Area	Yield	Supply	Area	Yield	Supply	Area	Yield	Supply
Short term	5.46 ***	11.39 ***	16.85	0.44 **	1.08 ***	1.52	−0.07	0.03	−0.04
Long term	7.27 ***	13.89 ***	21.16	0.40 **	0.70 ***	1.10	−0.10	0.02	−0.08
Adjustment	0.75 ***	0.82 ***	1.57	1.10 ***	1.54 ***	2.64	0.76 ***	1.15 ***	1.90

Source: author's calculations. *** significant at the 1% level; ** significant at the 5% level.

Alemu et al. (2003) estimated the supply response of agricultural output to the prices of *teff* and wheat in Ethiopia and reported the short-term elasticities of 0.14 and 0.15 for *teff* and wheat, respectively, and the long-term elasticity of 0.28 for both crops using time-series data from 1966 to 1994. Abrar and Morrissey (2006) estimated the supply response of agricultural output to prices in Ethiopia and reported short-term elasticities of 0.07, −0.02 and 0.27 for *teff*, wheat, and barley, respectively, using panel data from Northern Ethiopia during 1994 to 2000. Abrar et al. (2004b) also estimated the supply response of agricultural output to prices in Ethiopia and reported short-term elasticities of 0.28, 0.22, and 0.04 for *teff*, wheat, and barley, respectively, during 1994 to 1997. Dercon and Ayalew (1995) studied the export supply response of coffee to the export price and reported the short-term elasticity of 0.17 and the long-term elasticity of 0.27.

In sub-Saharan Africa (SSA), Magrini et al. (2018) estimated the supply responses of main staple food crops and reported acreage, production, and yield response ranges from a 0.08 acreage response using the farm gate price to a 0.63 production response using wholesale price proxies in SSA over the period 2005–2013 based on country panel data. The effects of prices on supply responses in Africa have been estimated by considering agricultural aggregates (Bond 1983; McKay et al. 1999; Thiele 2003). Bond (1983) estimated the individual crop-level and aggregate supply responses of the agricultural output to the prices of various crops in nine SSA countries. He reported individual crop price elasticities ranging from 0.02 to 0.87 in the short term and from 0.07 to 1.81 in the long term from 1962 to 1981. McKay et al. (1999) studied the aggregate supply response in Tanzanian agriculture and estimated that the long-term elasticity of the aggregate food crop output to the relative prices was almost unity, while the short-term supply responses were estimated at 0.35 for aggregate food crops and all (food and export) crops. Thiele (2003) estimated that border price supply elasticities tend to lie between 0.20 and 0.50 in SSA countries covering the period 1965–1999. In addition, Leaver (2004) used an adapted Nerlovian model to study the price elasticity of the supply for tobacco output in Zimbabwe from 1938 to 2000 and reported a short-term elasticity of 0.34 and a long-term elasticity of 0.81, suggesting that tobacco farmers are highly responsive to output price changes. Rahji and Adewumi (2008) obtained a higher long-term price elasticity of rice production in Nigeria (1.58) between 1960 and 2004, further verifying the crucial role of the supply response in agricultural markets in developing countries.

Imai et al. (2011) studied the extent to which the production of different agricultural commodities, namely, maize, wheat, rice, fruit, vegetables, and oilseeds, responds to price changes in 10 Asian countries and reported a short-term elasticity ranging from 0.25 to 0.31 for these commodities. Zhai et al. (2019) used the system GMM estimator using provincial-level panel data (1997–2016) and reported partial adjustments (i.e., At-1 and Pt-1) of 0.21 and 0.87, respectively, for the green fodder supply in China. Similarly, Brockhaus et al. (2015) presented new evidence using provincial panel data over the period 1995–2012 for rice, wheat, and corn supply responses in China. They used the system GMM estimator and reported price elasticities ranging from 0.16 (rice) to 0.34 (wheat). Mythili (2012)

studied the supply responses of rice, wheat, maize, grams, groundnuts, rapeseed, mustard, sugarcane, and cotton using state-level panel data over the period of 1970–2000 in India. He used the GMM estimator and reported price elasticities ranging from 0.084 (rice) to 0.338 (grams) in the short term and from 0.408 (rice) to 1.15 (grams) in the long term in terms of the acreage response, whereas the elasticities ranged from 0.071 (rice) to 0.321 (maize) in the short term and from 0.085 (grams) to 0.393 (maize) in the long term in terms of the yield response. Surekha (2005) also reported a similar result for rice, indicating that farmers in India are responsive to price changes. Rahman (2007) estimated the price elasticity of Bangladesh tea production to be 1.10. Another study by Nerlove and Addison (1958) reported a short-term elasticity of 0.02 and a long-term elasticity of 4.7 for spinach in the USA. Generally, cropping decisions in India are affected by agro-climatic conditions, land characteristics, and farmers' knowledge about the crop, in addition to the price variable (Gulati and Kelly 1999).

In the short term, land availability cannot be improved without huge investments. Moreover, delays in the supplies of production capital contribute to delayed supply responses, and labor availability cannot change except through increasing populations or relocation among sectors or regions. Long-term supply responses require labor and capital increases, which take place over a relatively long time, as well as farmers' decisions to invest and adopt new technology that enables them to increase output. In contrast, fertilizers, improved seeds, and pesticides are the only variable inputs whose application can be adjusted in the short term to policy incentives. However, the applications of these inputs to Ethiopian agriculture are low. The application of improved seeds accounted for less than 1% of the total seeds, less than 47% of the respondents use fertilizer, less than 5% of the total area was irrigated, and there was almost no usage of pesticides or insecticides.

4. Conclusions and Policy Implications

My results are quite similar to those obtained from the supply responses of agricultural outputs to price incentives and nonprice incentives from Ethiopia and other countries, although they all used different functional forms, estimation methods, time spans and data types (cross-sectional, time-series, or panel data), and region- and country-specific factors related to technology, the economic structure, and macro constraints. My study has strengthened the findings of previous studies, namely, by indicating that farmers are quite responsive to price changes, particularly in the longer term (Food and Agriculture Organization 2016). This is a good start for making market-based policies work, even in rural Africa (Kumbhakar and Heshmati 1995; Kumbhakar and Hjalmarsson 1995). This paper sought to establish some general conclusions on supply responsiveness by taking these data and methodological limitations into account. My trustworthiness is increased, as I used data from a large sample and employ recent econometric estimation methods that, to some extent, have not been used in such settings before in Ethiopia.

This study measured the dynamic supply responses of major cereal crops to price incentives and nonprice factors in Ethiopia. Through the Nerlovian expectation approach, in conjunction with a dynamic panel data model, the system-generalized method of moments was used for the estimation. Price incentives and nonprice factors such as rainfall, adult education, land quality, fertilizer, and farm size affect the aggregate output supply of major cereal crops in the country. The study also investigated the effects of price increases on the supply response before and after price increases since 2006. Estimates of the agricultural supply relative to the expected price exhibited large variations across crops and time. There are considerable supply responses to increases in the prices of major cereal crops in Ethiopia. The area and yield responses of major cereal crops are responsive to price incentives.

The planted area and produced yield are quite responsive to price incentives and nonprice factors for major cereal crops in Ethiopia, based on the estimated short-term and long-term elasticities. Moreover, the long-term estimates are much larger than the short-term values for *teff*. The agricultural output responses to price incentives and nonprice variables are lower in the short term because most factors affecting agricultural production are fixed in the short term. The elasticities for a household-level crop area planted and yield produced with respect to the crop price are positive and statistically

significant for both *teff* and barley but not for wheat. The cross-price elasticities are statistically significant for barley and wheat but not for *teff*, indicating that *teff* is a basic food in the country. More specifically, *teff* is identified as a complementary crop of barley by the model, as the sown area of barley in response to the lagged price of *teff* is positive. Moreover, wheat is identified as a competitive crop of barley by the model, as the sown area of barley in response to the price of wheat is negative. Meanwhile, the *teff* sown-area response is not influenced by the prices of any of these major cereal crops (barley and wheat). In addition, the yield responses to lagged-price elasticities are positive and statistically significant for *teff* and barley. Furthermore, current price elasticity is positive and significant for wheat yield response. Hence, the supply responses evaluated alongside the acreage and yield responses are responsive to price increases. Overall, the coefficients associated with area responses more consistently reveal the expected signs compared to those of the yield responses. This finding is consistent with standard economic theory and intuition in that area decisions are less sensitive to weather changes compared to yields and are under the control of the householders' decisions. Moreover, there is a statistically significant supply response difference before and after the price increases from 2006 in the case of *teff* and wheat areas, as well as *teff*, barley, and wheat yields. For example, *teff* is becoming the most demanded crop, hence, its area has increased; in contrast, wheat is imported by the government, and its area decreased after 2006. For barley, there has been an increase in the yield, and it is clearly evidenced by the statistics, given that barley is becoming a commercial crop.

This study supports the notion that major cereal food price changes may induce the production of a large supply of food grains. This study implies that the expansions of both *teff* and barley areas are possible in the country. This is important because *teff* is one of the major food crops consumed locally (by approximately 110 million people of the country) and demanded globally because of its use in gluten-free products, whereas barley is another food crop demanded because of its use in low glycemic index products and is becoming a commercial crop with the expansion of the domestic brewery industry. However, the wheat area is least affected by own price. This is partly explained by the growing volume of wheat imports by the country. These findings also imply that the agriculture sector in Ethiopia is responsive to output price increases, which was a common phenomenon in 2007 and 2008 worldwide. Thus, I claim that the growth record of Ethiopian agriculture over the last decade is partly explained by the increased agricultural prices, which were driven by local, regional, and international factors. This relationship implies that promoting access to markets by allowing farmers to receive higher prices enhances the income of smallholders, increases the national food supply, and narrows inequity.

Ethiopian (developing countries) agriculture needs improvement in terms of input supply (such as improved seeds, fertilizer, irrigation, infrastructure, and farm management) to enhance the welfare of the farmers and society as a whole using a mixture of markets and government policy interventions. Competitive markets enable more efficient allocation of scarce resources and allow the supply and demand to set prices. Markets also enhance cost-effective and flexible resource allocation. Unlike many developing countries, most resources in modern economies are allocated via markets rather than by governments. The main role of the government ought to be to establish the rules and institutions needed for markets to work, not to control the price signals from markets.

However, there are occasions when markets fail, which could justify government interventions to correct these market failures. The reasons for such failure include information asymmetries, noncompetitive markets, principal-agent problems, and externalities. Effective markets require government intervention in the establishment and operation of a secure property rights system, the provision of information, macroeconomic stability, endowment redistribution, and support for social capital. Government should intervene via subsidies, quotas, restrictions, expenditures on research and development, infrastructure (irrigation, transport, and communication), property ownership rights, education and extension services, risk coping, and management strategies, and the adoption of new technology to enhance production in addition to price incentives.

Furthermore, the government should enhance economic growth and development in the country to improve the purchasing power of food buyers. The government should also provide subsidies for smallholder farmers to allow them to use improved technologies, train farmers on how to use new technologies, lift export bans, place higher tariffs on food imports to enhance local production until domestic markets work better, and stabilize the prices so that smallholder farmers can easily make area allocation decisions for specific crops. Better agricultural trade policies are required to encourage more effective supply responses. The research and development of modern technologies to improve production and productivity in Ethiopia should also strengthen the supply response of agriculture, in addition to price incentives. A fine-tuned balance between government interventions and market solutions is important, in addition to improving farmers’ agronomic practices, for increasing agricultural production and, thus, farmers’ and consumers’ welfare.

Funding: The author is grateful for the financial assistance received from the Norwegian State Educational Loan Fund.

Acknowledgments: The author would like to thank Addis Ababa University (AAU), the Centre for the Study of Africa Economics (CSAE) at Oxford, and the International Food Policy Research Institute (IFPRI) for Ethiopia Rural Household Survey (ERHS) data, and the Ethiopian National Meteorological Service Agency for rainfall data used in this article. The constructive and helpful comments received from Eirik Romstad, Menale Kassie, Gudbrand Lien, Mette Wik, Stein T. Holden, Daniel Muluwork and Getaw Tadesse at different stages of preparing this article are extremely appreciated.

Conflicts of Interest: The author declares no conflict of interest.

Appendix A. Derivations of the Nerlovian Expectation and Adjustment Coefficients

By imposing a restriction indicating that $\beta = 1$ and substituting Equations (2) and (3) into Equation (1), a reduced form equation is derived as follows:

$$P_t^e = P_{t-1}^e + \beta P_{t-1} - \beta P_{t-1}^e \tag{A1}$$

$$A_t = A_{t-1} + \gamma A_t^d - \gamma A_{t-1} \tag{A2}$$

Substitute Equation (A1) into Equation (1), where $\beta = 1$:

$$A_t^d = \alpha_0 + \alpha_1 P_{t-1}^e + \alpha_1 P_{t-1} - \alpha_1 P_{t-1}^e + \alpha_2 Z_t + v_t A_t^d = \alpha_0 + \alpha_1 P_{t-1} + \alpha_2 Z_t + u_t \tag{A3}$$

Substitute Equation (A3) into Equation (A2):

$$A_t = A_{t-1} + \gamma(\alpha_0 + \alpha_1 P_{t-1} + \alpha_2 Z_t + u_t) - \gamma A_{t-1} \tag{A4}$$

$$A_t = A_{t-1} + \gamma \alpha_0 + \gamma \alpha_1 P_{t-1} + \gamma \alpha_2 Z_t + \gamma u_t - \gamma A_{t-1} \tag{A5}$$

Collect like terms:

$$A_t = \gamma \alpha_0 + \gamma \alpha_1 P_{t-1} + \gamma \alpha_2 Z_t + (1 - \gamma) A_{t-1} + \gamma v_t$$

The equation becomes:

$$A_t = a_0 + a_1 P_{t-1} + a_2 Z_t + a_3 A_{t-1} + v_t \tag{A6}$$

Because A_t^d and P_t^e are unobservable, they are eliminated from the system. This elimination of unobserved variables leads to the reduced form, from which the key parameters can be retrieved. Similarly, the Nerlovian model can also be described in terms of the output as:

$$Y_t^d = \alpha_0 + \alpha_1 P_t^e + \alpha_2 Z_t + v_t \tag{A7}$$

$$P_t^e - P_{t-1}^e = \beta(P_{t-1} - P_{t-1}^e), 0 \leq \beta \leq 1 \tag{A8a}$$

$$Y_t - Y_{t-1} = \gamma(Y_t^d - Y_{t-1}), 0 \leq \gamma \leq 1 \tag{A8b}$$

where Y_t^d is the desired level of output; Y_t is the actual level of output; p_t^e is a vector of the expected level of prices for period t ; Z_t represents the nonprice factors; α_i are parameters; and v_t accounts for unobserved random factors with zero expected value. Equation (A7) states that the desired level of output depends on the expected price level and other nonprice factors. The Nerlovian model is developed to take two dynamic processes into account: adaptive expectations and partial adjustments. Desired levels of outputs cannot be observed by farmers due to latency; thus, Nerlove postulates the hypothesis known as partial adjustment (Equation (A8b)), where γ is the coefficient of adjustment, $(Y_t - Y_{t-1})$ is the actual change in output, and $(Y_t^d - Y_{t-1})$ is the desired change in output. Equation (A9a) indicates that the actual change in output at any given time t is some fraction γ of the desired change for the period. If $\gamma = 1$, the actual output is equal to the desired output; that is, the actual output adjusts to the desired output instantaneously. However, if $\gamma = 0$, there is no change since the actual output at time t is the same as that observed in the previous period. Generally, γ lies between these extreme values since adjustment to the desired output is likely to be constrained by policy and natural lags.

In the Nerlove model, Equation (A8b) states that for each period, the farmers revise the price that they expect to prevail in the coming period to correct the mistakes they made in predicting the price during this period. It shows how price expectations can be described based on differences between actual and past prices, where p_t^e is the expected price for period t ; P_{t-1} is the price that prevails when decision making for production in period t occurs; and β is the adaptive-expectation coefficient. This shows that expectations are revised during each period by a fraction β from the gap between the current value of a price and the previous expected value. Thus, expectations about the price level are revised by farmers by a fraction β due to policy inconsistencies that affect the price level observed in the current period and the anticipated value in the previous period. If $\beta = 1$, expectations are realized immediately and fully, that is, during the same period. If, on the other hand, $\beta = 0$, expectations are static; that is, the conditions prevailing today will be maintained in all subsequent periods. However, expectations are seldom fully realized, and there is usually a gap between the actual and expected level of prices because of constraints from public policies and nonpolicy variables.

To use the Nerlovian model for estimation, it is necessary to transform Equations (A7)–(A8b) into their reduced forms. In the reduced form, the partial-adjustment variable Y_t^d is associated with the desired output and the adaptive-expectation variable P_t^e . Adaptive price expectations can be transformed into distributed lag structures in the form of the past level of output and the previously expected price level. This is consistent with the Nerlovian model, which is based on price expectations and output adjustments. The process necessary to arrive at the reduced form equation is shown below. Taking the two constants in these equations, β and γ , by imposing a restriction that $\beta = 1$ and substituting Equations (A8a) and (A9a) into Equation (A7), a reduced form of the equation is derived as follows:

$$P_t^e = P_{t-1}^e + \beta P_{t-1} - \beta P_{t-1}^e \tag{A9a}$$

$$Y_t = Y_{t-1} + \gamma Y_t^d - \gamma Y_{t-1} \tag{A9b}$$

Substitute Equation (A9a) into Equation (A7) where $\beta = 1$:

$$Y_t^d = \alpha_0 + \alpha_1 P_{t-1}^e + \alpha_1 P_{t-1} - \alpha_1 P_{t-1}^e + \alpha_2 Z_t + v_t Y_t^d = \alpha_0 + \alpha_1 P_{t-1} + \alpha_2 Z_t + v_t \tag{A10}$$

Substitute Equation (A10) into Equation (A9b):

$$Y_t = Y_{t-1} + \gamma(\alpha_0 + \alpha_1 P_{t-1} + \alpha_2 Z_t + u_t) - \gamma Y_{t-1} \tag{A11}$$

$$Y_t = Y_{t-1} + \gamma \alpha_0 + \gamma \alpha_1 P_{t-1} + \gamma \alpha_2 Z_t + \gamma u_t - \gamma Y_{t-1} \tag{A12}$$

Collect like terms:

$$Y_t = \gamma\alpha_0 + \gamma\alpha_1 P_{t-1} + \gamma\alpha_2 Z_t + (1 - \gamma)Y_{t-1} + \gamma v_t$$

The equation becomes:

$$Y_t = a_0 + a_1 P_{t-1} + a_2 Z_t + a_3 Y_{t-1} + v_t \quad (\text{A13})$$

where

$$a_0 = \gamma\alpha_0, a_1 = \gamma\alpha_1, a_2 = \gamma\alpha_2, a_3 = 1 - \gamma, v_t = \gamma v_t$$

Hence,

$$a_3 = 1 - \gamma, \therefore \gamma = 1 - a_3, a_0 = \gamma\alpha_0, a_0 = (1 - a_3)\alpha_0, \therefore \alpha_0 = \frac{a_0}{1 - a_3}$$

$$a_1 = \gamma\alpha_1, a_1 = (1 - a_3)\alpha_1, \therefore \alpha_1 = \frac{a_1}{1 - a_3}, a_2 = (1 - a_3)\alpha_2, \therefore \alpha_2 = \frac{a_2}{1 - a_3}$$

The a_i parameters are the short-term elasticities, while α_i are the long-term elasticities. Note that $(1 - a_3)$ is the coefficient of partial adjustment (acreage or yield).

References

- Abebe, H. Gabrie. 1998. The Supply Responsiveness of Peasant Agriculture in Ethiopia: Some Macroeconomic Results from Cereals Production. *Ethiopian Journal of Economics* 7: 1–23.
- Abrar, Suleiman, Oliver Morrissey, and Tony Rayner. 2004a. Aggregate Agricultural Supply Response in Ethiopia: A Farm-Level Analysis. *Journal of International Development* 16: 605–20. [\[CrossRef\]](#)
- Abrar, Suleiman, Oliver Morrissey, and Tony Rayner. 2004b. Crop-Level Supply Response by Agro-Climatic Region in Ethiopia. *Journal of Agricultural Economics* 55: 289–311. [\[CrossRef\]](#)
- Abrar, Suleiman, and Oliver Morrissey. 2006. Supply Response in Ethiopia: Accounting for Technical Inefficiency. *Agricultural Economics* 35: 303–17. [\[CrossRef\]](#)
- African Development Bank Group. 2016. *Federal Democratic Republic of Ethiopia Country Strategy Paper 2016–2020*. Abidjan: AfDB.
- Alem, Braha. 1996. Trade Liberalization and External Balance in Ethiopia: The Question of Sustainability. In *Adjustments in Ethiopia: Lessons for the Road Ahead*. Edited by Taddess Abadi and Tekie Alemu. Addis Ababa: Ethiopian Economic Association.
- Alemu, Zerihun G., K. Oosterhuizen, and Herman van Schalkwyk. 2003. Grain-Supply Response in Ethiopia: An Error-Correction Approach. *Agrekon* 42: 389–404. [\[CrossRef\]](#)
- Ampadu-Ameyaw, Richard, and Dadson Awunyo-Vitor. 2014. Effect of Price and Non-price Incentives on Production and Marketable Surplus of Food Crops Supply in Ghana. *Asian Journal of Agricultural Extension, Economics & Sociology* 3: 666–79.
- Anderson, Kym, and William A. Masters. 2007. *Distortions to Agricultural Incentives in Africa*. Washington, DC: World Bank.
- Arellano, Manuel, and Stephen Bond. 1991. Some Tests of Specification for Panel Data: Monte Carlo Evidence and an Application to Employment Equations. *The Review of Economic Studies* 58: 277–97. [\[CrossRef\]](#)
- Arellano, Manuel, and Olympia Bover. 1995. Another Look at the Instrumental Variable Estimation of Error-Components Models. *Journal of Econometrics* 68: 29–51. [\[CrossRef\]](#)
- Askari, Hossein, and J. Thomas Cummings. 1977. Estimating Agricultural Supply Response with the Nerlove Model: A Survey. *International Economic Review* 18: 257–92. [\[CrossRef\]](#)
- Awlachew, Seleshi B., Teklu Erkossa, and Regassa Namara. 2010. *Irrigation Potential in Ethiopia—Constraints and Opportunities for Enhancing the System*. Colombo: International Water Management Institute.
- Baltagi, Badi. 2008. *Econometric Analysis of Panel Data*. New York: John Wiley & Sons.
- Bellemare, Marc F., Christopher B. Barrett, and David R. Just. 2013. The Welfare Impacts of Commodity Price Volatility: Evidence from Rural Ethiopia. *American Journal of Agricultural Economics* 95: 877–99. [\[CrossRef\]](#)

- Blundell, Richard, and Stephen Bond. 1998. Initial Conditions and Moment Restrictions in Dynamic Panel Data Models. *Journal of Econometrics* 87: 115–43. [\[CrossRef\]](#)
- Bond, Marian E. 1983. Agricultural Responses to Prices in Sub-Saharan African Countries (Réactions du secteur agricole aux prix en Afrique au sud du Sahara) (Reacciones de la agricultura ante los precios en los países del Africa al sur del Sahara). *IMF Staff Papers* 30: 703–26. [\[CrossRef\]](#)
- Braulke, Michael. 1982. A Note on the Nerlove Model of Agricultural Supply Response. *International Economic Review* 23: 241–44. [\[CrossRef\]](#)
- Brockhaus, Jan, Jikun Huang, Jiliang Hu, Matthias Kalkuhl, Joachim von Braun, and Guolei Yang. 2015. *Rice, Wheat, and Corn Supply Response in China*. San Francisco: Agricultural and Applied Economics Association.
- Central Statistical Agency. 2014. *Federal Democratic Republic of Ethiopia, 2009–2014 Years. Statistical Abstracts and Statistical Bulletins*. Addis Ababa: CSA.
- Coelli, Timothy J., D. S. Prasada Rao, Christopher J. O'Donnell, and G. Edward Battese. 2005. *An Introduction to Efficiency and Productivity Analysis*. Berlin: Springer.
- Colman, David. 1983. A Review of the Arts of Supply Response Analysis. *Review of Marketing and Agricultural Economics* 51: 201–30.
- Dercon, Stefan, and Lulseged Ayalew. 1995. Smuggling and Supply Response: Coffee in Ethiopia. *World Development* 23: 1795–813. [\[CrossRef\]](#)
- Dercon, Stefan, and John Hoddinott. 2004. *The Ethiopian Rural Household Surveys: Introduction*. Washington, DC: International Food Policy Research Institute.
- Di Marcantonio, Federica, Cristian Morales-Opazo, Jesus Barreiro-Hurle, and Mulat Demeke. 2014. Determinants of Food Production in Sub Saharan Africa: The Impact of Policy, Market Access and Governance. In *2014 International Congress*. Ljubljana: European Association of Agricultural Economists, pp. 26–29.
- Diebold, Francis X., and Russell L. Lamb. 1997. Why are Estimates of Agricultural Supply Response so Variable? *Journal of Econometrics* 76: 357–73. [\[CrossRef\]](#)
- Durevall, Dick, Josef L. Loening, and Yohannes Ayalew Birru. 2013. Inflation Dynamics and Food Prices in Ethiopia. *Journal of Development Economics* 104: 89–106. [\[CrossRef\]](#)
- Ezekiel, Mordecai. 1938. The Cobweb Theorem. *The Quarterly Journal of Economics* 52: 255–80. [\[CrossRef\]](#)
- Food and Agriculture Organization. 2016. *Federal Democratic Republic of Ethiopia: Country Programming Framework-CPF, 2016–2020*. Rome: FAO.
- Gulati, Ashok, and Tim Kelly. 1999. *Trade Liberalization and Indian Agriculture: Cropping Pattern Changes and Efficiency Gains in Semi-Arid Tropics*. New York: Oxford University Press.
- Haile, Mekbib G., Matthias Kalkuhl, and Muhammed A. Usman. 2015. Market Information and Smallholder Farmer Price Expectations. *African Journal of Agricultural and Resource Economics* 10: 297–311.
- Headey, Derek D. 2016. *Food Prices and Poverty*. Washington, DC: The World Bank.
- Holtz-Eakin, Douglas, Whitney Newey, and Harvey S. Rosen. 1988. Estimating Vector Autoregressions with Panel Data. *Econometrica* 56: 1371–95. [\[CrossRef\]](#)
- Imai, Katsushi S., Raghav Gaiha, and Ganesh Thapa. 2011. Supply Response to Changes in Agricultural Commodity Prices in Asian Countries. *Journal of Asian Economics* 22: 61–75. [\[CrossRef\]](#)
- Jaunky, Vishal C. 2013. Democracy and Economic Growth in Sub-Saharan Africa: A Panel Data Approach. *Empirical Economics* 45: 987–1008. [\[CrossRef\]](#)
- Just, Richard E. 1993. Discovering Production and Supply Relationships: Present Status and Future Opportunities. *Review of Marketing and Agricultural Economics* 61: 11–40.
- Khan, Sufyan U., Muhammad A. Faisal, Zahoor Ul Haq, Shah Fahad, Ghaffar Ali, Arshad A. Khan, and Imran Khan. 2019. Supply Response of Rice Using Time Series Data: Lessons from Khyber Pakhtunkhwa Province, Pakistan. *Journal of the Saudi Society of Agricultural Sciences* 18: 458–61. [\[CrossRef\]](#)
- Kumbhakar, Subal C., and Almas Heshmati. 1995. Efficiency Measurement in Swedish Dairy Farms: An Application of Rotating Panel Data, 1976–88. *American Journal of Agricultural Economics* 77: 660–74. [\[CrossRef\]](#)
- Kumbhakar, Subal C., and Lennart Hjalmarsson. 1995. Labour-Use Efficiency in Swedish Social Insurance Offices. *Journal of Applied Econometrics* 10: 33–47. [\[CrossRef\]](#)
- Leaver, Rosemary. 2004. Measuring the Supply Response Function of Tobacco in Zimbabwe. *Agrekon* 43: 113–31. [\[CrossRef\]](#)
- Magrini, Emiliano, Jean Balié, and Cristian Morales-Opazo. 2017. Cereal Price Shocks and Volatility in Sub-Saharan Africa: What Really Matters for Farmers' Welfare? *Agricultural Economics* 48: 719–29. [\[CrossRef\]](#)

- Magrini, Emiliano, Jean Balié, and Cristian Morales-Opazo. 2018. Price Signals and Supply Responses for Staple Food Crops in Sub-Saharan Africa. *Applied Economic Perspectives and Policy* 40: 276–96. [CrossRef]
- McKay, Andrew, Oliver Morrissey, and Charlotte Vaillant. 1999. Aggregate Supply Response in Tanzanian Agriculture. *The Journal of International Trade & Economic Development* 8: 107–23.
- Minot, Nicholas W. 2010. *Transmission of World Food Price Changes to Markets in Sub-Saharan Africa*. Washington: International Food Policy Research Institute.
- Minot, Nicholas W. 2014. Food Price Volatility in Sub-Saharan Africa: Has it Really Increased? *Food Policy* 45: 45–56. [CrossRef]
- Muth, John F. 1961. Rational Expectations and the Theory of Price Movements. *Econometrica* 29: 315–35. [CrossRef]
- Mythili, Gurumurthy. 2012. *Acreage and Yield Response for Major Crops in the Pre-and Post-Reform Periods in India: A Dynamic Panel Data Approach*. Mumbai: Indira Gandhi Institute of Development Research.
- Nakelse, Tebila, Timothy J. Dalton, Nathan P. Hendricks, and Manzamasso Hodjo. 2018. Are Smallholder Farmers Better or Worse off from an Increase in the International Price of Cereals? *Food Policy* 79: 213–23. [CrossRef]
- National Bank of Ethiopia. 2019. *Annual Report 2018/2019*. Addis Ababa: National Bank of Ethiopia.
- National Bank of Ethiopia. 2015. Daily Exchange Rate. Available online: <https://nbebank.com/commercial-banks-exchange-rate/> (accessed on 17 April 2015).
- Nerlove, Marc. 1956. Estimates of the Elasticities of Supply of Selected Agricultural Commodities. *Journal of Farm Economics* 38: 496–509. [CrossRef]
- Nerlove, Marc. 1958. *The Dynamics of Supply: Estimation of Farmer's Response to Price*. Baltimore: The Johns Hopkins Press.
- Nerlove, Marc, and William Addison. 1958. Statistical Estimation of Long-Run Elasticities of Supply and Demand. *Journal of Farm Economics* 40: 861–80. [CrossRef]
- Nerlove, Marc. 1979. The Dynamics of Supply: Retrospect and Prospect. *American Journal of Agricultural Economics* 61: 874–88. [CrossRef]
- Nickell, Stephen. 1981. Biases in Dynamic Models with Fixed Effects. *Econometrica* 49: 1417–26. [CrossRef]
- NMSAE. 2014. *Mean Annual Rainfall Distribution of Ethiopia*. Addis Ababa: National Meteorological Service Agency of Ethiopia (NMSAE).
- OECD, and Food and Agriculture Organization of the United Nations. 2016. *OECD-FAO Agricultural Outlook 2016–2025*. Paris: OECD.
- Ogundari, Kolawole. 2018. Maize Supply Response to Price and Nonprice Determinants in Nigeria: Bounds Testing Approach. *International Transactions in Operational Research* 25: 1537–51. [CrossRef]
- Rahji, M. A., and Matthew O. Adewumi. 2008. Market Supply Response and Demand for Local Rice in Nigeria: Implications for Self-Sufficiency Policy. *Journal of Central European Agriculture* 9: 567–73.
- Rahman, Mohammad L. 2007. Impact of Price and Other Factors on Tea in Bangladesh: Sources of Variation and Disparity over Division. *BRAC University Journal* 4: 9–11.
- Rashid, Shahidur. 2010. *Staple Food Price in Ethiopia. Prepared for the COMESA Policy Seminar on Variation in Staple Food Prices: Causes, Consequence, and Policy Options, Maputo, Mozambique, 25–26 January 2010 Under the African Agricultural Marketing Project (AAMP)*. Addis Ababa: The Federal Democratic Republic of Ethiopia.
- Roodman, David. 2009. How to do Xtabond2: An Introduction to Difference and System GMM in Stata. *The Stata Journal* 9: 86–136. [CrossRef]
- Sadoulet, Elisabeth, and Alain de Janvry. 1995. *Quantitative Development Policy Analysis*. Baltimore: Johns Hopkins University Press.
- Shonkwiler, John S., and Suzanne Hinckley. 1985. A Generalized Supply Response/Factor Demand Model and its Application to the Feeder Cattle Market. *Western Journal of Agricultural Economics* 10: 245–53.
- Singh, Inderjit, Lyn Squire, and John Strauss. 1986. *Agricultural Household Models: Extensions, Applications, and Policy*. Baltimore: Johns Hopkins University Press.
- StataCorp. 2013. *Stata Statistical Software: Release 13*. College Station: StataCorp LP.
- Surekha, K. B. Rao. 2005. Modeling Nonlinear Autoregressive Distributed Lag Models: A New Approach. *Journal of Quantitative Economics* 3: 101–14. [CrossRef]
- Taffesse, Alemayehu S., Paul Dorosh, and Sinafikeh Asrat. 2012. Crop Production in Ethiopia: Regional Patterns and Trends. In *Food and Agriculture in Ethiopia: Progress and Policy Challenges*. Edited by Paul Dorosh and Shahidur Rashid. Philadelphia: University of Pennsylvania Press, pp. 53–83.

- Talukder, Byomkesh, and Alison Blay-Palmer. 2017. Comparison of Methods to Assess Agricultural Sustainability. In *Sustainable Agriculture Reviews. Sustainable Agriculture Reviews*. Edited by Eric Lichtfouse. Cham: Springer International Publishing, pp. 149–68.
- Tenaye, Anbes. 2020a. Sources of Productivity Growth in Ethiopian Agriculture. *African Journal of Agricultural Research* 15: 19–32.
- Tenaye, Anbes. 2020b. Technical Efficiency of Smallholder Agriculture in Developing Countries: The Case of Ethiopia. *Economies* 8: 34. [CrossRef]
- Tenaye, Anbes, and Endrias Geta. 2009. Analysis of Vulnerability and Determinants of Enset Production in Wolaita, Southern Ethiopia. *Acta Horticulturae* 806: 663–68. [CrossRef]
- Thiele, Rainer. 2003. Price Incentives, Non-price Factors and Agricultural Production in Sub-Saharan Africa: A Cointegration Analysis. *African Development Review* 15: 425–38. [CrossRef]
- Wickens, Michael, and J. N. Greenfield. 1973. The Econometrics of Agricultural Supply: An Application to the World Coffee Market. *The Review of Economics and Statistics* 55: 433–40. [CrossRef]
- Worako, Tadesse K. 2012. *Dynamics of Food Price Trends and Policy Options in Ethiopia*. Addis Ababa: Ethiopian Development Research Institute.
- World Bank. 2013. Ethiopia-Household Income, Consumption and Expenditure Survey 1999–2000-Survey Based Harmonized Indicators (SHIP) Dataset. Available online: <https://microdata.worldbank.org/index.php/catalog/1068/get-microdata> (accessed on 11 June 2020).
- World Bank. 2018. World Development Indicators: Country Profile. Available online: <http://data.worldbank.org/country/ethiopia> (accessed on 25 January 2020).
- Zerihun, Gudeta. 1999. Usufruct Rights in Land in Grain Supply Response Analysis: The Case of Ethiopia. *Ethiopian Journal of Economics* 5: 81–99.
- Zhai, Shengying, Qihui Chen, and Wenxin Wang. 2019. What Drives Green Fodder Supply in China?—A Nerlovian Analysis with LASSO Variable Selection. *Sustainability* 11: 6692. [CrossRef]



© 2020 by the author. Licensee MDPI, Basel, Switzerland. This article is an open access article distributed under the terms and conditions of the Creative Commons Attribution (CC BY) license (<http://creativecommons.org/licenses/by/4.0/>).

Article

Economics of Waste Prevention: Second-Hand Products in Germany

Henning Wilts *, Marina Fecke and Christine Zeher

Wuppertal Institute for Climate, Environment and Energy gGmbH, 42103 Wuppertal, Germany; Marina.Fecke@wupperinst.org (M.F.); Christine.Zeher@wupperinst.org (C.Z.)

* Correspondence: Henning.Wilts@wupperinst.org

Abstract: Reuse is still seen as a “niche phenomenon” and consumers seem to waste economic opportunities linked to buying and selling second-hand products. For this reason, this paper focuses on incentives and barriers to sell and buy second-hand products, as indicated in the literature, and applies a theoretical framework of transaction costs to explain the existing consumption patterns. For this paper, a representative online survey was conducted in which 1023 consumers in Germany participated, age 16 and older. The data were analyzed for statistically significant deviations between different groups of economic actors selling or buying second-hand products. Results show that valuable unused products exist in households, but barriers such as uncertainties about the reliability of the buyer or the quality of the product hinder the transition into sustainable consumption. Different forms of transaction costs are important explanatory variables to explain why consumers nevertheless predominantly buy new products, although they are aware that second-hand would save money and make an individual contribution to climate protection.

Keywords: circular economy; second-hand; reuse; transaction costs

Citation: Wilts, Henning, Marina Fecke, and Christine Zeher. 2021.

Economics of Waste Prevention: Second-Hand Products in Germany. *Economics* 9: 74. <https://doi.org/10.3390/economics9020074>

Academic Editor: George Halkos

Received: 8 April 2021

Accepted: 7 May 2021

Published: 12 May 2021

Publisher’s Note: MDPI stays neutral with regard to jurisdictional claims in published maps and institutional affiliations.



Copyright: © 2021 by the authors. Licensee MDPI, Basel, Switzerland. This article is an open access article distributed under the terms and conditions of the Creative Commons Attribution (CC BY) license (<https://creativecommons.org/licenses/by/4.0/>).

1. Introduction

Against the background of steadily increasing consumption of natural resources and environmental burdens caused by the currently dominant linear patterns of production and consumption, circular economy approaches have raised significant attention in scientific literature and among policy makers (e.g., [European Commission 2020](#)). The transition towards a circular economy in which the value of products and raw materials are contained at the end of their use phase, is seen as a crucial precondition for an absolute decoupling of resource use and economic wellbeing, e.g., achieving the climate targets agreed on in the Paris Accord.

Although many circular economic strategies focus on optimized recycling processes, the European Commission’s Circular Economy Action Plan places a specific emphasis on the reuse of products that are no longer needed ([European Commission 2020](#)). From an environmental perspective and thus according to the waste hierarchy, reuse offers higher resource saving potentials than recycling—a large part of the necessary efforts in the production phase of products can be avoided and only in a very few cases; e.g., a significantly reduced energy consumption of newer products would overcompensate these advantages ([Von Gries 2020](#)). Specific quantification of saved resources or mitigated GHG emissions depends on the specific framework conditions, e.g., to what extent second-hand products actually replace virgin products ([Keith 2011](#)). In addition, in terms of cost savings and other socioeconomic objectives, reuse of products seems to be an obvious solution for products that are no longer wanted. Taking the example of packaging, switching to 20% reusable solutions could lead to USD 10 billion of business opportunities ([Ellen MacArthur Foundation 2019](#)), according to Rreuse, an European association for reuse, 296 new jobs could be created by treating only 10,000 tons of municipal solid waste ([Rreuse 2015](#)).

However, despite this consideration of reuse as a win–win opportunity that should align environmental and economic objectives of a circular economy, product reuse is actually a “niche phenomenon” (European Environment Agency 2018) of limited economic relevance for most product groups. According to the European Environment Agency’s progress report on waste prevention, the total turnover of the European second-hand sector is below 1% of the total retail sector and below 0.01% of Europe’s gross added value. Official statistics exist for only a few product groups, such as electronic and electrical products, and only a few countries show a share of reused products of more than 1% (Eurostat 2020). Taking Germany as an example, a study initiated by the Environmental Protection Agency estimated an annual market volume of just 4 kg per capita, including online platforms, e.g., eBay (Von Gries et al. 2017).

Against this background, this paper takes the gap between pure market opportunities and the reality of reuse as a “niche phenomenon” as the starting point to focus on barriers for reuse. It builds up on several papers that have focused on specific drivers or barriers, but to the authors’ understanding, it does not provide a systematic framework on how these barriers translate into reduced economic incentives to sell or buy second-hand products. Farooq Baqal and Abdulkhaleq (2018) highlighted that second-hand products in general are gaining more prominence because “products produced today will be outdated tomorrow and in order to go for an advanced version, there is a need to sell used products”. Previous research on barriers for reuse has, e.g., highlighted differences between various products groups, such as whether products have traces of previous owners (Edbring et al. 2016). Behrendt et al. (2011) identified five types of eBay users who trade based on very different incentives, inter alia so-called “prosumers” that already consider the reselling potential of products when buying them. On average, Mukherjee et al. (2020) also identified economic incentives as an important driver of using second-hand products. Such incentives become even more relevant as the purchase of previously used merchandise has been transformed “from a second-class act” into a worldwide fashion trend related to buying something “cool” and “stylish” (Hristova 2019). Klug et al. (2015), inter alia, highlighted the issue of trust as an important barrier for purchasing second-hand products.

In order to provide new insights on the actual relevance of incentive structures, this paper draws on economic transaction cost theories, a specific branch of literature within the so-called new institutional economics (NIE). The focus here is on the costs of using market mechanisms, e.g., for economic transactions such as the sale or purchase of second-hand products. This perspective contradicts the simplistic neoclassical assumptions that every market participant is fully informed about everything, now and in the future—at zero costs (Simon 1959; Coase 1998). Instead, so-called transaction costs occur, related to the gathering, validation, and processing of information, and can lead to path dependencies in which, from an economic point of view, inferior options (i.e., buying new products) have higher market shares than they should have in an optimal equilibrium, simply because standards and routines have evolved over decades to minimize such transaction costs (Yousuf 2017). Following Alston and Gillespie (1989), this paper differentiates transaction costs as analytical variables based on the different phases of market transactions: costs of finding suitable business partners, costs of negotiating contracts, and finally costs of monitoring whether the agreed products or services actually have the contractually agreed quality. Vakis et al. (2003) identifies these empirical approaches as an important research gap in the area of new institutional economics.

The aim of this paper is to contribute to current research by first providing an empirical basis for the actual relevance of the incentives and barriers mentioned in the literature above, and second, by applying a theoretical framework of transaction costs for both sellers and buyers of second-hand products to explain the gap described: How to explain the fact that consumers seem to waste economic opportunities linked to buying and selling second-hand products? How can the concept of transaction costs be operationalized in order to show its relevance for market exchanges?

For this purpose, the paper is structured as follows: Section 2 describes the materials and methods used—the data gathering and the theoretical framework for its analysis. Section 3 shows the results, Section 4 discusses the conclusions that can be drawn from the empirical results, and the last section draws conclusions, particularly regarding efficient policy formulation to support reuse, and further research needed to develop a consistent theoretical framework for the economics of waste prevention.

2. Methodology

For this paper, a representative online survey was conducted in which consumers in Germany participated, age 16 and older (Wilts and Fecke 2020). The participants were selected based on a standardized consumer panel in order to allow statistically significant conclusions differentiating gender, age groups, living conditions (urban, periurban, and rural) and spatial location within Germany (north, south, east, west). The participants were approached in September 2020 and thus between the two major COVID-19 waves and linked shutdowns, which might have influenced responses due to economic uncertainties or increased importance, e.g., hygienic concerns (Sueßbauer et al. 2020). On average, it took the participants 12 min to fill in the questionnaire; only completed questionnaires were taken into account.

The data sample included 1023 persons, selected from a predefined panel allowing for weighting of variables listed above in relation to national mean values. The panel of interviewees had a share of 52% females, 53% were age 50 and older, 79% were living in the western part of Germany, 32% had a university degree, and 38% indicated a net household income of EUR 2500 or higher. Fifty-one percent of the interviewees had bought at least second-hand item during the last 12 months and 46% offered products for reuse.

The questionnaire was developed in cooperation with eBay Kleinanzeigen, which is one of the largest online platforms for second-hand products in Germany. It included a total of 31 questions, 9 of which referred to general demographic aspects of the participant. The remaining 22 questions focused on selling used products, the purchase of second-hand products, and perceptions of climate and sustainability issues. The interviewees were given five different options to assess their agreement with specific statements (fully agree, partly agree, etc.). In a last step, the answers were weighted with regard to the factors indicated above. For the analysis, the answers were structured using cross-correlation analysis in order to show deviations from average answer patterns.

Based on the conceptual literature on transaction costs, the following matrix structure in Table 1 was developed that structures potential transaction costs that might hinder the market development for second-hand products. The framework differs between the phases of exchange as described in Section 1, specifically for buyers and sellers of second-hand products. This Table 1 was used to develop the questionnaire for the empirical part of the research presented in the section that follows.

Table 1. Transaction costs in different phases of market exchange.

Transaction Costs of	Finding Partners	Negotiation	Monitoring
Selling	products must be described, photographed, and uploaded/submitted to market platforms; often necessary registration and confirmation process; sometimes also direct costs such as handling fees	time-consuming communication with potential buyers; information gathering to assess market prices	
Buying	variety of different platforms that must be checked for best offers; e.g., auctions require specific attention uncertainty about seller reliability	time-consuming communication with potential sellers, e.g., with regard to product qualities	uncertainties about the actual quality of the product offered risk of fraud by the seller, e.g., product not delivered

3. Results

The following presents the results of the online survey that are divided into three parts: data on selling (Section 3.1) and buying second-hand products (Section 3.2); general attitudes on sustainability aspects as drivers for sale/purchase second-hand products (Section 3.3); and the final step (Section 3.4), which focuses on the relevance of specific barriers based on a statistical analysis of these data.

3.1. Selling Second-Hand Products

The survey results show that consumers own a significant number of products that they consider no longer used or needed. When asked about specific product groups that the survey interviewees have not used in at least 12 months but still nevertheless keep in their households, 62% mentioned CDs, DVDs, or Blue Ray Discs, 58% indicated books, and 57% clothing and shoes. Interestingly, 6% also mentioned cars as completely unused property. Figure 1 shows how the participants assessed the total value of these items that were unused for at least twelve months. The majority of participants estimated the value to be between EUR 250 and 499; nevertheless, the percentages are rather equally distributed between less than EUR 100 and up to EUR 2499, resulting in an average amount of EUR 1289. It should be noted that such self-assessments bear significant uncertainties, e.g., regarding the value of product depreciation years after the actual purchase. Nevertheless, the results in terms of number and value of products are consistent with previous analyses, e.g., [Huisman et al. \(2017\)](#).

Taking into account the economic potential that a household could realize by selling these unused products, it seems surprising that only 46% of participants reported selling at least one of these products, and only 30% sell one or more products at least every three months. Twenty-three percent of consumers, asked in the survey, do not get rid of products at all, and thus these items occupy an increasing amount of space in their flats or houses. Forty-seven percent of them simply discard unused products as waste, despite their economic value—this refers mainly, but not only, to broken products. When asked why they do not take advantage of the opportunity to turn such products into additional income, 12% answered that they are not aware of channels for selling used products, 24% mentioned the necessary efforts as an important barrier. Concerning this additional effort, 49% emphasized the time required, 34% lack information about the residual value of the products they want to sell, 32% have trust issues with potential buyers and are afraid of fraud, and 31% noted that communication with potential buyers simply takes too much time.

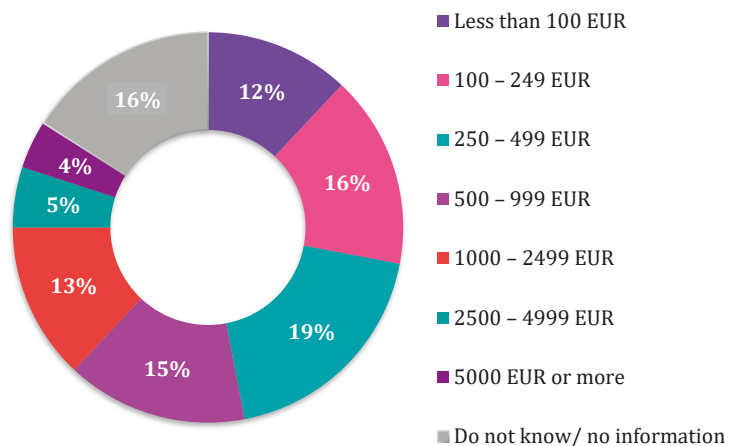

Figure 1. Estimated average value of unused products in the household. Source: authors' results.

3.2. Buying Used Products

In a second part, the participants were asked about their role as purchasers of used products. Of the 1023 interviewees, the majority indicated economic incentives as important advantages of buying second-hand products in comparison to virgin products: 56% agreed that they were able save costs and 36% indicated that they would not have afforded the products at the original retail price. Environmental benefits and avoiding unnecessary wastage of natural resources was indicated by 42%, and a third key driver seems to be the availability of products that are no longer for sale (34%).

Despite these economic incentives, only 29% of the survey participants bought more than one used product during the last twelve months. The results show that a large percentage of second-hand purchases is done by a relatively small group of participants who buy a product on a weekly or even daily basis. Table 2 illustrates the important barriers that were recorded—most refer to uncertainties about the reliability of the buyer or the quality of the product. Consistent with the abovementioned analysis by Hristova (2019), only 4% mentioned a general reluctance towards second-hand products as something that is only relevant for those who cannot afford new products. Potential buyers do not seem to be held back by unjustified prices, but by specific risks and uncertainties that would require them to invest more time in the validation of given information on the products for sale. Taking these barriers into account, the interviewees mentioned various product groups that less than a quarter would even consider buying second-hand. This includes inter alia smartphones, large electronic appliances, or car spare parts—all are considered as particularly resource-intensive and often contain critical raw materials (Sander et al. 2019).

Table 2. Key barriers in buying used products. Source: authors' results.

Key Barriers in Buying Used Products	in %
I do not know if the products are functional	52%
I do not know if the seller is trustworthy	46%
I do not know if the products are really as described/pictured	34%
I have no information on how the product was used before	33%
I do not know if the products are hygienically safe	21%
I just feel more comfortable with new products	17%
The search for used products costs a lot of time	14%
Buying used products is more time consuming because I do not have the wide selection/availability as with new goods	9%
Communication with the salesperson is exhausting	8%
Used products are something for people who cannot afford new goods	4%
Other	2%
Do not know/no information	6%

3.3. Attitudes towards Sustainability and Climate Protection

A third group of questions referred to the personal attitudes towards sustainable consumption and climate protection and their relevance for the willingness to buy second-hand products. Table 3 shows the significantly different answers of those who actually bought a second-hand product during the last twelve months and those who completely focused on buying virgin products. Here, 66% compared to only 28% who did not buy a second-hand product agreed with the statement that used products are an attractive alternative to new products; 55% compared to 25% mentioned that buying second-hand products is seen as an element of sustainable consumption.

However, even of those interviewees who did not buy a single second-hand product in the last year, 55% agreed that second-hand products are good for the environment. There is also little difference between the shares of interviewees who mentioned that sustainable consumption should include buying less—it could be argued that this is an indication to second-hand as a consistency rather than a sufficiency strategy for sustainability. Almost half of the survey participants do not seem to see a necessity to question consumption patterns as long as the products purchased have a lower environmental footprint (Sachs 2015). Those consumers who already bought a used product in the past also indicated a higher willingness to buy more second-hand in the future (63% compared to 30%).

Table 3. Agreement to specific statements related to sustainability depending on previous purchases of second-hand products. Authors' results.

Agreement to Specific Statements Related to Sustainability Depending on Previous Purchases of Second-Hand Products	No Used Products Bought in the Last 12 Months	Purchased Used Products at Least Once in the Last 12 Months
Sustainable action is becoming more important not only in consumption, but also in every day	67%	75%
Used products are good for the environment	55%	73%
Used products are an attractive alternative to new products for me	28%	66%
Sustainable action in everyday life is becoming more important for me	53%	66%
In everyday life, I pay a lot of attention to conserving resources	58%	64%
Buying second-hand will be an economically better alternative to buying new in the future	35%	57%
For me, sustainable consumption means buying less	50%	56%
For me, sustainable consumption means buying used products	25%	55%
Second-hand products are something for people who cannot afford new goods	27%	16%
N (total)	478	519

3.4. Relevance of Specific Barriers for Reuse

Based on these data, Tables 4 and 5 show an analysis of the relevance of specific barriers for (a) buying and (b) selling second-hand products. For this analysis, data on relevant barriers were checked for statistically significant deviations between regular buyers/sellers (more than four products per year) and those who indicated not to buy/sell any second-hand products. The table highlights deviations with a β error of $p \geq 0.1$.

The results highlight that different barriers seem to be of different relevance based on the frequency of selling/buying second-hand products. Interestingly, the perceived relevance of some barriers seems to increase, whereas others seem to decrease when consumers gain experiences with second-hand products. Experienced consumers put a stronger emphasis on insufficient descriptions of second-hand products and in general more often confirmed that buying second-hand products is more time consuming than regular purchases of new products. On the other hand, concerns about hygienic conditions of products and a general reliance on new products seem to decrease when consumer purchase second-hand products on a more regular basis. Concerning selling second-hand products, it is not surprising that the challenge of finding suitable market places is perceived as less relevant when consumers are used to offering their products more than four times a year. In addition, the general mistrust in buyers seems to decrease. On the other hand, experienced sellers emphasized the time-consuming communication with potential consumers.

Table 4. What are the three most significant disadvantages of buying used?

q12	All	q15	
		I Repeatedly Buy Products Used Yes in %	No in %
I do not know if the products are really as described/pictured	34%	41	29%
I do not know if the products are functional	52%	52%	51%
I do not know if the products are hygienically safe	21%	13%	26%
I have no information how the product was used before	32%	35%	32%
The search for used products costs a lot of time	13%	17%	11%
Communication with the salesperson is exhausting	8%	10%	7%
Buying used products is more time consuming because I do not have the wide selection/availability as with new goods	9%	12%	8%
Used products are something for people who cannot afford new goods	4%	3%	5%
I just feel more comfortable with new products	17%	8%	25%
I do not know if the seller is trustworthy	46%	48%	42%
Other	2%	3%	2%
Do not know/no indication	6%	6%	8%
N (total)	1023	289	485

Table 5. What are the three largest barriers to selling used products?

q22	All	q18	
		Less Frequently than 1× per Year in %	More than 4× a Year in %
The sale of used products is time consuming	49%	54%	59%
Communication with the buyer is exhausting	31%	33%	45%
I do not know the price I used product is still worth	34%	35%	28%
I do not know how and where to sell used products	7%	10%	4%
I am afraid of being cheated	32%	33%	26%
Selling to strangers is too unsafe for me	20%	14%	6%
Other	7%	3%	11%
Do not know/no indication	17%	15%	14%
N (total)	1023	80	139

4. Discussion

The empirical results of the online survey and its analysis confirm various points of the existing literature on drivers/barriers for second-hand products. There seems to be a high willingness and acceptance amongst consumers to consider second-hand products as an alternative to buying new products—with economic incentives and environmental benefits as key drivers, see (Klug et al. 2015; Mukherjee et al. 2020; Budică et al. 2015). In this regard, the survey focusing on Germany seems to be consistent with international data (Bortoleto 2015). It should nevertheless be taken into account that overall reuse figures in Germany are quite low compared to neighbor countries such as, e.g., Belgium and France, inter alia due to high shares of exports for second hand goods (Borusiak et al. 2020). This specific gap between intention and actual behavior also seems to confirm the guiding research hypothesis on different forms of transaction costs as an important explanatory variable in order to explain why consumers nevertheless predominantly buy new products

although they are aware that second-hand would save money and make an individual contribution to climate protection, also taking into account the ratio of price and depreciated value of the product (OECD 2006).

The data presented seem to indicate that these general conclusions are based on perceptions that clearly diverge between different subgroups: younger cohorts emphasized the economic advantages and less the environmental benefits; they also indicate a lower willingness to modify consumption patterns for environmental objectives such as resource or climate protection compared to interviewees aged 60 and older, for example. This questions conclusions, e.g., by Rubik et al. (2019), who highlighted the increasing environmental awareness especially of children and younger people. Despite such differences between different social subgroups, the overwhelming majority of interviewees support the concept of extending use phases of products by reuse and in practice buy only a small share of previously used products and also do not offer significant amounts of products for sale, although they are unused and of considerable monetary value, see Urbański and Ul Haque (2020).

Concerning the research question of this paper, the consideration of transaction costs leads to plausible insights into certain drivers and barriers for the second-hand market, but of course raises the question of quantifying these costs for the use of the market mechanism. This issue has been highlighted by several authors who criticize the fact that transaction costs tend to be measured rather indirectly as divergence from an assumed optimal market equilibrium: “while the body of descriptive and theoretical literature on transactions costs is extensive, the empirical literature has been lagging” (Vakis et al. 2003). Especially, when transaction costs are prohibitively high and, in our case, virgin products offer a viable alternative, it is challenging to assess the absolute value of these additional costs.

The analytical perspective of transaction costs seems to be helpful for explaining this gap (Yousuf 2017). The costs of gathering and validating information on exchange partners and specific products seem to be of such relevance that those actors who focus on economic advantages decide that virgin products offer the better cost–benefit ratio. Furthermore, even those actors indicating environmental reasons as an important driver for buying/selling second-hand seem to conclude that other options to reduce their resource or climate footprint offer easier and thus more efficient ways to save the planet. The analysis presented here adds a dynamic perspective on such transaction costs. The relevance of specific barriers for reuse seems to change if market actors—as buyers as well as sellers—engage in more frequent transactions, including second-hand products. With an increasing number of products that are offered/bought every year, some barriers caused by such transaction costs gain in relevance, others are perceived as less important.

5. Conclusions

This paper analyses the relevance of specific transaction costs as a barrier for market transactions for second-hand products, and thus for the development of a reuse market segment that could contribute to resource conservation and climate change mitigation. Obviously, transaction costs are only one variable among many that determine the decision to sell/buy second-hand products, but they lead to a lower market equilibrium than would be optimal if all information about the trustworthiness of buyers/sellers and the quality of the products offered were available at zero or lower costs.

Taking into account the aggregated level of transaction costs that would have to be added to the actual price for which a product is bought or sold, this perspective allows a better understanding of why the market volume for second-hand products is still small compared to virgin products. The data on sustainability attitudes of buyers as well as sellers of second-hand products also lead to the hypotheses that a large share of the market volume is due to actors with a higher intrinsic motivation, which could compensate these additional transaction costs to a certain extent.

The analysis allows for drawing conclusions on specific policy instruments in this context. Taking into account the level of transaction costs linked to purchasing or selling

second-hand products, policies to support reuse should aim to decrease the necessary time and efforts to gather, evaluate, and monitor information, e.g., concerning the quality of products. Standardized regulations, i.e., regarding warranties or return options, could significantly increase incentives to consider second-hand as a viable alternative for new products. Considering that 66% of interviewees who already bought a used product during the last twelve months indicated their willingness to engage in additional second-hand transactions, it could be an option to subsidize the first purchase of a second-hand product, e.g., by providing vouchers. Similar incentives schemes for repair services have proven to be very effective (Stadt Wien 2021) because consumers gain insights on how to use relevant channels, and because the thresholds are lowered, transaction costs are reduced.

The results presented here are of course limited and preliminary as they are based on national data for Germany alone; as discussed above, even regional differences might be of significant relevance and results may differ in countries with more established reuse structures. In addition, the data are based on an online survey, the perception of transaction costs and barriers might thus be biased and subjective. Future research should therefore focus on more standardized empirical approaches to measuring transaction costs as a basis for assessing the economics of waste prevention, e.g., by taking into account the time required, the number of decisions to be made, and the number of stakeholders to be involved. The current lack of comparable data on the efficiency of waste prevention matters is also reflected in waste prevention policies, which rarely use market-based instruments, inter alia due to uncertainties about the relevance of transaction costs and thus about the actual effects of supporting second-hand products by reducing VAT rates (Wilts 2015), for example. The conceptual approach developed here for understanding second-hand markets could be a starting point for such a much more comprehensive analysis of the effectiveness and efficiency of waste prevention policies.

Author Contributions: H.W. was responsible for the conceptualization, methodology, and original draft preparation. Data curation was organized by M.F. and review and editing completed by C.Z. All authors have read and agreed to the published version of the manuscript.

Funding: This research was funded by the German Federal Ministry of Research and Education within the context of the project “PUR–RESOURCE EFFICIENT PACKAGING WASTE PREVENTION”.

Institutional Review Board Statement: Not applicable.

Informed Consent Statement: Informed consent was obtained from all subjects involved in the study.

Data Availability Statement: The data presented in this study are available on request from the corresponding author. The data are not publicly available due to confidentiality issues.

Conflicts of Interest: The authors declare no conflict of interest.

References

- Alston, Lee J., and William Gillespie. 1989. Resource coordination and transaction costs: A framework for analyzing the firm/market boundary. *Journal of Economic Behavior & Organization* 11: 191–212. [CrossRef]
- Behrendt, Siegfried, Christine Henseling, and Lorenz Erdmann. 2011. Chancen und Grenzen für einen nachhaltigen Konsum. In *Wiederverkaufskultur im Internet—Chancen für Nachhaltigen Konsum am Beispiel von eBay*. Edited by Siegfried Behrendt, Birgit Blättel-Mink and Jens Clausen. Berlin and Heidelberg: Springer, pp. 189–96. [CrossRef]
- Bortoloto, Ana Paula. 2015. *Waste Prevention Policy and Behaviour. New Approaches to Reducing Waste Generation and Its Environmental Impacts*. London: Routledge.
- Borusiak, Barbara, Andrzej Szymkowiak, Elena Horska, Natalia Raszka, and Elżbieta Żelichowska. 2020. Towards building sustainable consumption: A study of second-hand buying intentions. *Sustainability* 12: 875. [CrossRef]
- Budică, Ilie, Oprea Valentin Buşu, Aurelia Dumitru, and Mona-Lisa Purcaru. 2015. Waste management as commitment and duty of citizens. *Polish Journal of Management Studies* 11: 7–16.
- Coase, Ronald. 1998. The New Institutional Economics. *American Economic Review* 88: 72–74.
- Edbring, Emma Gullstrand, Matthias Lehner, and Oksana Mont. 2016. Exploring consumer attitudes to alternative models of consumption: Motivations and barriers. *Journal of Cleaner Production* 123: 5–15. [CrossRef]
- Ellen MacArthur Foundation. 2019. Reuse. Rethinking Packaging. Available online: <https://www.ellenmacarthurfoundation.org/assets/downloads/Reuse.pdf> (accessed on 12 January 2021).

- European Commission. 2020. Circular Economy Action Plan. For a Cleaner and More Competitive Europe. Available online: https://ec.europa.eu/environment/circular-economy/pdf/new_circular_economy_action_plan.pdf (accessed on 12 January 2021).
- European Environment Agency. 2018. *Waste Prevention in Europe—Policies, Status and Trends in Reuse in 2017*. EEA Report 4. København: European Environment Agency.
- Eurostat. 2020. Computer and Personal and Household Goods Repair Statistics—NACE Rev. 2. Available online: https://ec.europa.eu/eurostat/statistics-explained/index.php?title=Computer_and_personal_and_household_goods_repair_statistics_-_NACE_Rev_2 (accessed on 12 January 2021).
- Farooq Baqal, Yusra, and Shlair Abdulkhaleq. 2018. Analysis of Factors Influencing the Decisions over Purchasing Second-Hand Products. *International Journal of Social Sciences & Educational Studies* 4: 80–90. [CrossRef]
- Hristova, Yulia. 2019. The Second-Hand Goods Market: Trends and Challenges. *Izvestia Journal of the Union of Scientists Varna. Economic Sciences Series, Union of Scientists Varna, Economic Sciences Section 8*: 62–71. [CrossRef]
- Huisman, Jaco, Pascal Leroy, Francois Tertre, Maria Ljunggren Söderman, Perrine Chancerel, Daniel Cassard, Amund N. Løvik, Patrick Wäger, Duncan Kushnir, Susanne Rotter, and et al. 2017. *Prospecting Secondary Raw Materials in the Urban Mine and Mining Wastes (ProSUM)—Final Report*. Brussels: ProSUM Consortium, ISBN 978-92-808-9060-0.
- Keith, James. 2011. A Methodology for Quantifying the Environmental and Economic Impacts of Reuse. Available online: <https://www.wrap.org.uk/sites/files/wrap/Final%20Reuse%20Method.pdf> (accessed on 12 January 2021).
- Klug, Martin, Miriam Rusch-Rodosthenous, and Philip Heldt. 2015. Die Weiternutzung gebrauchter Produkte—Potenziale und Risiken für Verbraucher und Gestaltungsmöglichkeiten für die organisierte Verbraucherarbeit. *Sozialwissenschaften und Berufspraxis* 38: 219–31. [CrossRef]
- Mukherjee, Srabanti, Biplab Datta, and Justin Paul. 2020. The phenomenon of purchasing second-hand products by the BOP consumers. *Journal of Retailing and Consumer Services* 57. [CrossRef]
- OECD. 2006. *Improving Recycling Markets*. Paris: OECD Publishing. [CrossRef]
- Reuse. 2015. Briefing on Job Creation Potential in the Re-Use Sector. Available online: <https://www.reuse.org/wp-content/uploads/Final-briefing-on-reuse-jobs-website-2.pdf> (accessed on 12 January 2021).
- Rubik, Frieder, Ria Müller, Richard Harnisch, Brigitte Holzhauser, Michael Schipperges, and Sonja Geiger. 2019. *Umweltbewusstsein in Deutschland 2018*. Dessau: UBA.
- Sachs, Wolfgang. 2015. Suffizienz. Umriss einer Ökonomie des Genug. *Uwif UmweltWirtschaftsForum* 23: 3–9. [CrossRef]
- Sander, Knut, Frank Marscheider-Weidemann, Henning Wilts, Julia Hobohm, Thorsten Hartfeil, Dirk Schöps, and René Heymann. 2019. *Abfallwirtschaftliche Produktverantwortung unter Ressourcenschutzaspekten (RePro)*. Dessau-Roßlau: Umweltbundesamt.
- Simon, Herbert A. 1959. Theories of decision making in economics and behavioural science. *American Economic Review* 49: 253–83.
- Stadt Wien. 2021. Wien Repariert's. Ihr Wiener Reparaturbon. Available online: <https://mein.wien.gv.at/wienerreparaturbon/#/> (accessed on 12 January 2021).
- Sueßbauer, Elisabeth, Henning Wilts, Sarah Julie Otto, Jennifer Schinkel, Klara Wenzel, Justus Caspers, Rabea-Lorina Dehning, and Svenja Jürgens. 2020. Ausweg aus dem Einweg? Auswirkungen der Coronakrise auf das Verpackungsabfallaufkommen in Deutschland. *Müll und Abfall* 10. [CrossRef]
- Urbański, Mariusz, and Adnan Ul Haque. 2020. Are you environmentally conscious enough to differentiate between greenwashed and sustainable items? A global consumers perspective. *Sustainability* 12: 1786. [CrossRef]
- Vakis, Renos, Elisabeth Sadoulet, and Alain de Janvry. 2003. *Measuring Transactions Costs from Observed Behavior: Market Choices in Peru*. Berkeley: Department of Agricultural and Resource Economics. Available online: <https://escholarship.org/uc/item/7p81h66q> (accessed on 6 January 2021).
- Von Gries, Nadja, Henning Wilts, and Markus Meissner. 2017. *Schaffung einer Datenbasis zur Erfassung der Mengen von in Deutschland wiederverwendeten Produkten*. Dessau-Roßlau: Umweltbundesamt.
- Von Gries, Nadja. 2020. *Ressourceneinsparpotenziale der "Vorbereitung zur Wiederverwendung" von Elektro- und Elektronikgeräten*. Kassel: Kassel University Press. [CrossRef]
- Wilts, Henning, and Marina Fecke. 2020. ReUse und Secondhand in Deutschland Einstellungen zum Thema Abfallvermeidung und Nachhaltigkeit. Available online: <https://www.wupperinst.org/fa/redaktion/downloads/projects/ReUse-Secondhand-Studie.pdf> (accessed on 6 January 2021).
- Wilts, Henning. 2015. *Waste Prevention: A Survey of Policies and Programmes across the OECD*. ENV/EPOC/WPRPW(2015)13/FINAL. Paris: OECD. Available online: [https://one.oecd.org/document/ENV/EPOC/WPRPW\(2015\)13/en/pdf](https://one.oecd.org/document/ENV/EPOC/WPRPW(2015)13/en/pdf) (accessed on 12 January 2021).
- Yousuf, Allam. 2017. Transaction Costs: A Conceptual Framework. *International Journal of Engineering and Management Sciences* 2: 131–39. [CrossRef]

Article

Herbal-Based Cosmeceuticals and Economic Sustainability among Women in South African Rural Communities

Peter Tshepiso Ndhlovu¹, Abiodun Olusola Omotayo², Adeyemi Oladapo Aremu^{1,2,*} and Wilfred Otang-Mbeng³

¹ Indigenous Knowledge Systems (IKS) Centre, Faculty of Natural and Agricultural Sciences, North-West University, Private Bag X2046, Mmabatho 2745, North West Province, South Africa; Tshepiso.Ndhlovu@nwu.ac.za

² Food Security and Safety Niche Area, Faculty of Natural and Agricultural Sciences, North-West University, Private Bag X2046, Mmabatho 2745, North West Province, South Africa; omotayoabiodun777@gmail.com

³ School of Biology and Environmental Sciences, Faculty of Agriculture and Natural Sciences, University of Mpumalanga, Private Bag X11283, Mbombela 1200, Mpumalanga Province, South Africa; Wilfred.Mbeng@ump.ac.za

* Correspondence: Oladapo.Aremu@nwu.ac.za; Tel.: +27-18-389-2573

Received: 21 April 2020; Accepted: 21 June 2020; Published: 27 June 2020

Abstract: Access to natural resources in the immediate environment is an essential factor that contributes to livelihood in many rural areas. In the current study, we explored the economic potential(s) of the natural herbal-based cosmetic and cosmeceutical enterprise for the welfare of the Vhavenda women. A purposive sampling technique was used to collect data from 79 Vhavenda women and analysed with descriptive and inferential statistics (Tobit regression) as well as budgeting analysis. The majority (61%) of the participants were married with an average household size of five members. Additionally, 39% of the participants were already ageing with an average age-group of 56–70 years. The majority (44%) of the participants were not formally employed while the monthly average total income of R1841.01 (107.37 USD) was recorded with an average per capital expenditure of R1438.42 (83.89 USD). A budgeting cost ratio of 1.28 was recorded, which indicates that for every R1.00 (0.057 USD) invested in the herbal-based cosmetic and cosmeceutical production, an expected return of R1.28 (0.073 USD) was forecasted. Tobit regression results indicated that the determinants of the income of participants were experience level ($p < 0.01$), religion affiliation ($p < 0.05$) and consumption expenditure ($p < 0.01$) among others. Thus, a conscious, introspective and intentional look into this marginalised herbal-based cosmetic and cosmeceutical enterprise as a panacea for improved income and welfare of rural South Africans should be considered.

Keywords: budgeting analysis; rural household income; medicinal plants; women; sustainability; Tobit regression

1. Introduction

Plants are indispensable to the existence of humans, as they play several significant roles in maintaining the quality of life, nutrition and medicinal needs (Noorhosseini et al. 2019; Beltreschi et al. 2018; Lawal et al. 2020). In addition, natural-based cosmetics contribute to an increased income for rural households and communities as well as their overall welfare. Shackleton et al. (2007) argued that access to and the use of natural resources is important for poverty alleviation. Antignac et al. (2011) indicated that currently, there is an increasing demand for cosmeceutical products that contain natural and/or organic ingredients, especially in North America and Western Europe. Due to the increasing safety concerns associated with the use of

synthetic cosmetics, there is a renewed interest in exploring natural resources, especially plants, for herbal-based cosmetics and cosmeceuticals (Antignac et al. 2011; Mahomoodally and Ramjuttun 2016; Lall and Kishore 2014). Therefore, accessing and trading herbs for natural-based cosmetics has the potential to enhance the local economy. Furthermore, herbal-based cosmetics and cosmeceuticals are an important socio-cultural heritage in many rural communities. For instance, in Pakistan, herbs are used for preserving and enhancing the beauty and personality of human beings (Ahmad et al. 2008).

South Africa is known to have a remarkable plant diversity which is largely untapped in terms of its potential for medicinal and cosmetic purposes (Van Wyk 2011). Regardless of being a significant part of the natural and social assorted variety, only a few plants are currently marketed on commercial scale. According to Mander et al. (2007), the trade of medicinal plants in South Africa is a large and expanding industry, with estimated R2.9 billion contribution to the economy. However, the pricing structures fluctuate across markets and over-time as the cost of harvesting plant species varies depending on a gatherer's access to the resources and the proximity of markets to the harvesting sites (Williams et al. 2007). In South Africa, many plants are used by local communities as sources of cosmetics, medicines and food (Van Wyk 2015). Likewise, among the Vhavenda in Vhembe District Municipality of Limpopo province, South Africa, plants remain popular and well-enriched in their tradition and culture for different purposes (Rampedi and Olivier 2013). These diverse indigenous plants offer the rural communities valuable environmental resources that could be used to maintain the welfare of people living in this area.

Generally, the use and the impact of environmental resource has some degree of influence on household welfare among the indigenous communities in Southern Africa (Ntuli and Muchapondwa 2017; Thondhlana and Muchapondwa 2014). For instance, environmental income from resources such as cosmetics, fire wood, medicinal plants and wild fruits contribute about 20% to the total income of the indigenous San and Mier rural communities of Kalahari drylands in South Africa (Thondhlana and Muchapondwa 2014). Even though the actual financial benefits from the sale of plants and their products in the informal sector remain largely undocumented and form part of the 'hidden' economy, it is generally known that medicinal plants and their products contribute substantially to the economy of local communities in South Africa (Botha et al. 2004; Makunga et al. 2008). Research efforts have often neglected the socio-economic context of herbal-based cosmetics and cosmeceuticals as well as its contribution to the local economy. Particularly, there is a dearth of information regarding the economic potential of herbal-based cosmetics and cosmeceuticals among the Vhavenda women in Vhembe District Municipality, South Africa.

Thus, this study evaluated the socio-economic characteristics, the welfare status (proxied by their income) of the Vhavenda women, the profitability level of the herbal-based cosmetics and cosmeceuticals and the factors influencing the income generated from herbal-based cosmetics and cosmeceuticals in the study area. We intent to advocate and motivate timely policy intervention using the appropriate channels in order to drive and sustain funding and support for research on herbal-based cosmetics and cosmeceuticals. The current study is geared towards addressing the following research questions:

1. What are the socio-economic characteristics of the women involved in the trading of herbal-based cosmetics and cosmeceuticals in the study area?
2. What are the factors influencing the income generated from herbal-based cosmetics and cosmeceuticals in the study area?
3. Is herbal-based cosmetics and cosmeceuticals a profitable venture and to what extent is there profitability among women in Vhembe district area?

2. A Brief Literature Review on Herbal-Based Cosmetics and Cosmeceuticals

The history of herbal cosmetics in European and Western countries consists of very dark phase in the late 6th century when different concoctions and pastes were used to whiten the face; this practice

remained popular for over four hundred years (Chaudhri and Jain 2014). The early mixtures that were used in Europe for this purpose were so potent that they sometimes led to paralysis, strokes or death (Mansor et al. 2010). Globally, herbal-based cosmetics are gaining popularity as evidenced by rapidly increasing global and national markets of herbal products (De Janvry and Sadoulet 2001). The global therapeutic market was worth USD 550 billion and USD 900 billion in 2004 and 2009, respectively (Butler et al. 2014). The present demand for herbal-based cosmetics and cosmeceuticals is USD 14 billion per year and is projected to increase to USD 5 trillion by 2050 (Jeelani et al. 2017). Turnover rate for the herbal and Ayurveda industry in Sri Lanka, which is regarded as one of the leading markets, is approximately USD 2.5 billion per year (Booker 2014). The production and marketing of herbal products have been growing fast in many major markets including Germany, USA, France, China, Italy, Japan, UK and Spain (Mafimisebi et al. 2013).

According to Bilal et al. (Bilal et al. 2016), herbal cosmetics are highly valued and nearly three-quarters of the cosmetics and cosmeceuticals that are used globally are discovered from local plants. In addition, about 25% of modern cosmetics are derived from plants (Amit et al. 2010). Many synthetic cosmetics and cosmeceuticals are based on prototype mixtures which were isolated from plants. Thus, herbs are a potential source of therapeutics and have attained a significant role in health systems globally. However, communities in developing countries lack sufficient information on the social and economic benefits that could be derived from the industrial utilization of traditional plants. As indicated by Alves and Rosa (2007), apart from the use of these plants for local healthcare needs, information has to be available about market potential and trading possibilities.

Socio-economic factors such as household income, household size, the age, employment, and marital status and the educational attainment of the household head significantly affect the socio-economic status of households (Delpuech et al. 1999; Ndayambaje et al. 2012; Nguyen and Nguyen 2019). The welfare function may differ across the rural households and across circumstances, indicating that the same amount of real income may produce different levels of welfare (Anang and Yeboah 2019). Thus, an understanding of the impact of socio-economic and demographic factors provides an opportunity for profiling households to determine their needs. The level of education in most rural areas of developing countries is lower than what prevails in urban areas, which makes people in rural areas less likely to be employed in high paying jobs (Anang and Yeboah 2019). However, there are several dimensions of assessing welfare. Welfare indicators generally refer to a household's knowledge of their resources including income (Ndayambaje et al. 2012), which influences specific sociocultural determinants (Delpuech et al. 1999). When assessing the economic level of the household, it is important to observe that the variables used in computing the economic index reflect more the permanent living conditions of the households than current cash availability; a low economic level thus indicates medium to long-term poverty. Women in many rural communities engage in petty trading and other income earning activities to supplement household income (Anang and Yeboah 2019). In the context of the developing countries, where 70% of the population living in the rural areas are considered to be unemployed, their contribution to household activities is hindered (Sekhampu 2012).

3. Materials and Methods

3.1. Study Area

As detailed by Ndhlovu et al. (Ndhlovu et al. 2019), the study was conducted across 16 villages covering four municipalities in the Vhembe District Municipality, Limpopo Province of South Africa (Table 1). The study area is exceptionally endowed with numerous environmental biomes which can be used for herbal cosmetic production. Vhembe district has a landmass of 25,597 km² (Table 2), with the majority living in villages (Statistics South Africa 2012). Vhembe District Municipality contains noteworthy biodiversity and rich heritage (Ross 2017; Nhemachena et al. 2015). All (100%) the participants in the study area belong to the Vhavenda cultural group.

Table 1. Selected villages in the four local municipalities of Vhembe District Municipality, Limpopo province, South Africa.

Local Municipality	Villages
1. Collins Chabane municipality	1. Khakhanwa 2. Tondoni 3. Dididi 4. Tshikonelo
2. Makhado municipality	5. Tshakuma 6. Ludanani 7. Muhovheya 8. Dovhuni 9. Muguvhumi 10. Dlambele
3. Thulamela municipality	11. Mpego 12. Tshimutikili 13. Levumbhi 14. Mukomaasaanandou 15. Mukula
4. Musina	16. Folovhudwe

Table 2. Description of Vhembe District Municipality, Limpopo province, South Africa.

Description	Units
Area total	25,597 km ²
Population total	1,294,722 million people
Density	51/km ² (130/sq. mi)
Racial Makeup	Black African 98.2% Colored 0.1% Indian/Asian 0.4% White 1.1%
Languages	First language—Venda 67.2% Tsonga 24.8% Northern Sotho (Sepedi) 1.6 % Other languages 5.1 %
Sex	Male 590,509 (45.6%) Female 704,559 (54.4%)

3.2. Sampling Technique

In order to have meaningful information, the data were sampled within two major sampling methods, viz. the probability (one village from each municipality was selected randomly from the four municipalities) and non-probability methods as well as purposive (expert) sampling which is a participant selection tool widely used in ethnobotany (Tongco 2007). This sampling technique is also called judgment sampling, which is a cautious choice of participants due to the qualities of the information they possess. People with a specific profile were selected in order to obtain high quality and reliable information.

For the current study, the age of the participants ranged from 20 to 80 years old, and volunteers living in a rural environment and from a variety of socio-economic strata who had knowledge of herbal plants were contacted. A total of 79 Vhavenda women who had knowledge about herbal-based cosmetics and cosmeceuticals participated in the study. The data was collected using semi-structured questionnaire to probe questions relating to the contribution of herbal-based cosmetics and cosmeceuticals to the welfare of the Vhavenda women. Net income and profit index of knowledge holders that deal with herbal-based cosmetic and cosmeceutical were recorded.

3.3. Data Analysis

Descriptive statistics such as frequency counts, proportions, standard deviation and inferential statistics i.e., Tobit regression and Budgeting analysis were used to analyze and describe the socio-economic characteristics of the participants in the study area. Data analysis was conducted using SPSS version 25 and Stata SE version 11.

3.4. Theoretical Model and Empirical Specification

3.4.1. Tobit Regression

In this study, factors influencing the income generated from herbal-based cosmetics and cosmeceuticals were analysed using Tobit regression. Of the quantitative response models on welfare economics, the Tobit regression model is a hybrid of the discrete and continuous models, one of the analytical tools that favoured this study because of its dual purpose of measuring the elasticity of the probability on the herbal-based cosmetics and cosmeceuticals household’s income. Following the earlier studies (Ojimba 2013; Adelekan and Omotayo 2017; Awotide et al. 2019), the total income generated from the sales of herbal-based cosmetics and cosmeceuticals was the dependent variable. Given that the objectives of this study are beyond the determinants of a household’s income, to analyze the intensity of the households’ income, we therefore adopted the Tobit regression model. In addition, Tobit regression is an extension of the probit model which is useful for continuous values that are censored at or below zero as we have in this data set. When a variable is censored, regression models for truncated data provide inconsistent estimates of the parameters. The Tobit model assesses the probability of the household income, as well as the intensity or degree impact of the income obtained by women selling herbal-based cosmetics and cosmeceuticals in relation to their socio-economic and demographic characteristics. The Tobit model supposes that there is a latent unobserved variable g_i^* that depends linearly on z_i through a parameter vector α . There, τ_i is a normally distributed error term to capture the random influence on this relationship. The observed variable g_i is defined as being equal to the latent variable whenever the latent variable is above zero and equal to zero otherwise (1).

$$g_i = \begin{cases} g_i^* & \text{if } g_i^* > 0 \\ 0 & \text{if } g_i^* \leq 0 \end{cases} \tag{1}$$

where g_i^* is a latent variable:

$$g_i^* = \alpha z_i + \tau_i, \\ \tau_i \sim \mathcal{N}(0, \sigma^2)$$

If the relationship parameter α is estimated by regressing the observed g_i on z_i , the resulting Ordinary Least Squares estimator (OLS) is inconsistent. Freeman et al. (Freeman et al. 1998) have proven that the likelihood estimator suggested by Tobin (Tobin 1958) for this model is consistent. The likelihood function of the model (1) is given by L (Equation (2)).

$$L = \prod_0 F_i(g_i) \prod_i f_i(g_i) \tag{2}$$

$$L = \prod_0 [1 - F(z_i \alpha / \sigma)] \prod_i \sigma - f[(g_i - z_i \alpha) / \sigma]$$

where f and F are the standard normal density and cumulative distribution functions, respectively.

Then we can write the log-likelihood function (Equation (3)).

$$\log L = \sum_0 \log(1 - F(\mathcal{X}_i \alpha / \sigma)) + \sum_1 \log\left(\frac{1}{(2 \pi \sigma^2)^{1/2}}\right) - \sum_1 \frac{1}{2 \sigma^2} (g_i - \alpha z_i)^2 \tag{3}$$

which is there estimated by maximizing the log-likelihood function (Equation (4))

$$\begin{cases} \frac{\partial \log L}{\partial \sigma} = - \sum_0 \frac{z_i f\left(\frac{z_i - \alpha}{\sigma}\right)}{1 - F\left(\frac{z_i - \alpha}{\sigma}\right)} + \frac{1}{\sigma^2} \sum_1 (g_i - \alpha z_i) z_i = 0 \\ \frac{\partial \log L}{\partial \sigma^2} = \frac{1}{2\sigma^2} \sum_0 \frac{\alpha z_i f\left(\frac{z_i - \alpha}{\sigma}\right)}{1 - F\left(\frac{z_i - \alpha}{\sigma}\right)} - \frac{n_i}{2\sigma^2} + \frac{1}{2\sigma^4} \sum_1 (g_i - \alpha z_i)^2 = 0 \end{cases} \quad (4)$$

An iterative process is usually employed to obtain the maximum likelihood estimator of (Equation (4)), because they are non-linear. The variables used in the analysis are presented below. The dependent variable indicating the income (dollars) generated from herbal-based cosmetics and cosmeceuticals for the productive season under investigation. While the independent variables were experience (years), marital status, educational attainment (years), household size (actual number), age of the participants (years), teenagers, municipalities, tools used for production, market benefits, market trends, consumption patterns. Others are religious affiliation, expenditure, employment status, household size, children living in the household, produced products, teenagers, benefits of herbal-based cosmetics and cosmeceuticals, payment by consumers, participants' production cost, and consumption patterns of herbal-based cosmetics and cosmeceuticals. It was therefore hypothesized that herbal-based cosmetic and cosmeceutical income of the participants has nothing to do with the socio-economic characteristics of the study area.

3.4.2. Gross Margin Analysis

This was used to estimate the cost and return on herbal-based cosmetics and cosmeceuticals in the study area. The formula used for the calculations was as detailed by Daud et al. (2018). We estimate the cost and return on herbal-based cosmetic and cosmeceutical in the study area as:

$$GM = TR - TVC$$

$$\text{Benefit cost ratio (BCR)} = \frac{TR}{TC}$$

$$TC = TFC + TVC$$

where: TC = total cost, TR = total revenue, TC = total cost, TR = total revenue, TFC = total fixed cost, TVC = total variable cost, GM = gross margin.

4. Results and Discussion

4.1. Demographic Characteristics of the Participants

In the present study, the socio-economic characteristics that were considered included age, household size, employment status, educational level, marital status and years of experience (Delpuech et al. 1999; Celik and Hotchkiss 2000). As indicated in Table 3, the participants were grouped into four age groups and the majority (39%) of them were within the 56–70 years age group. The large number of old women in the business could translate into inability to accept or learn new methods/innovation. This implies that the old women might be unable to adopt new ideas and innovations to enhance productivity. Therefore, the legacy of the indigenous knowledge of herbal-based cosmetics and cosmeceuticals in Vhembe District Municipality is possibly in danger of being eroded with the passing away of these old women.

Table 3. Demography of the Vhavenda women who were knowledgeable about herbal-based cosmetics and cosmeceuticals in Vhembe District Municipality, Limpopo province, South Africa (n = 79).

Parameter	Frequency	Percentage (%)
Age distribution		
26–40 years	9	11
41–55 years	25	32
56–70 years	31	39
71 and above	14	18
Household size (individual/s)		
0–1	3	3.8
2–3	17	21.5
4–5	41	51.9
6 and more	18	22.8
Employment status		
Formal employment	4	5
Not employed	35	44
Part time	9	12
Self employed	11	14
Retired	16	20
Volunteering	4	5
Education status		
Informal education	18	23
Primary education	24	30
Secondary education	27	34
Tertiary education	10	13

On the other hand, [Arthur \(2005\)](#) indicated that older people tend to adhere strictly to traditional methods of production while younger people are often willing to adopt new methods and innovation in order to increase production. A similar finding was also observed by [Thondhlana and Muchapondwa \(2014\)](#). Households with older members (60 years and above) were small, in part, due to children moving away to seek new opportunities in towns and cities, or to start their own households. This could also lead to a lack of local production of natural-based cosmetics and cosmeceuticals. The current finding on age distribution indicates that the majority of the participants do not fall within the category of the preferable productive age group.

In terms of the size of the household, the majority (52%) consisted of 4–5 individuals (Table 3). These results are in line with the assertion of [Kyei \(2011\)](#). More so, [Arthur \(Arthur 2005\)](#) asserted that the size of the family is of high significance for the nation in general as well as to the welfare and wellbeing of the participants, the families and community. In this study, 52% of the participants were committed to small family size (Table 3). With 22.8% of participants with a family size of over 6 people, it can be inferred that only a few of the population was in support of large families, although the fact is that 52% responded in favour of a family size of above four but fewer children. The analysis invariably showed that the participants were committed to a smaller family size.

In the current study, formal education attainment was low among the participants. For instance, 23% did not receive a formal education, while 30% attended primary school only (Table 3). In addition, 34% of the participants had secondary education while 13% attended tertiary education. According to [Cameron and Harrison \(2012\)](#), formal education refers to an educational model to deliver a predefined curriculum and offered by institutions in a classroom-based setting. Vhembe is one of the districts with the lowest educational attainment among individuals aged 25–64 years ([Vhembe District Municipality 2016](#)). This implies that most of the participants were informally educated; hence the chances of adopting modern technology or different methods from other cultures could be lower ([Nmadu et al. 2015](#)). This could have affected their chances of using improved

technologies which require training and the reading of manuals in order to master modern techniques of cosmetic formulation. Low levels of education negatively affect the success of small- and medium-scale enterprises and programs. Education, particularly training, enhances the adoption of technology and improved methods which are a vital means to achieving higher productivity (Organisation of Economic and Co-Operation Development (OECD) 2018). However, the current findings were different from the study by Delpuch, Traissac, Martin-Pre'vel, Massamba and Maire (Delpuch et al. 1999).

Furthermore, the employment status variable indicated that 44% of the participants were unemployed (Table 3). The finding of this study aligns with the government statistics on unemployment for the study area (Statistics South Africa 2018). However, most of the participants engaged in multiple occupations thereby diversifying their source of income (Kyei 2011).

4.2. Tobit Regression Model of Factors Affecting Income Generated from Herbal-Based Cosmetics and Cosmeceuticals by the Participants

The determinants of income of the participants was estimated using Tobit regression. The F-test result shows that the estimates of an equation of the model are jointly significant at 1%, 5% and 10% levels. In addition, the computed Likelihood Ratio Chi Square statistics are statistically significant ($p < 0.01$) in the estimated model. This implies that the estimated parameters are not jointly equal to zero. The null hypothesis set at the methodological section is hereby rejected. From the 20 variables fitted in the model, year(s) of experience, expenditure and consumption patterns were statistically significant at 1% level. Additionally, variables such as teenagers in the household, teenagers, and payment by consumers were statistically significant at 5% level; while total number of children by participants and the age of the participants were statistically significant at 10% level (Table 4).

Table 4. Tobit Regression Model of income determinants of the herbal-based cosmetics and cosmeceuticals by Vhavenda women in Vhembe District Municipality, Limpopo province, South Africa (n = 79).

Parameter	Coefficient	Std. Error	t-Value	p-Value	Interval
Experience	-0.6160918	0.1160554	-5.31	0.000 ***	-0.3829877
Marital status	0.1674765	0.1204115	1.39	0.170	0.4093302
Religious affiliation	-0.6951942	0.3244218	-2.14	0.037 **	-0.0435738
Education attainment	0.1532906	0.1133938	1.35	0.183	0.3810487
Expenditure	0.6121074	0.115956	5.28	0.000 ***	0.8450119
Employment status	0.001468	0.0789941	0.02	0.985	0.1601323
Household size	0.0261993	0.0857474	0.31	0.761	0.1984281
Teenagers in the household	-0.4374788	0.4743294	-0.92	0.361	0.51524
Municipalities	-0.2031099	0.2212987	-0.92	0.363	0.2413816
Tools	-0.1488979	0.1018302	-1.46	0.150	0.055634
Products	-0.0635793	0.1074252	-0.59	0.557	0.1521906
Teenagers	1.05755	0.5049819	2.09	0.041 **	2.071836
Benefits of herbal-based cosmetic	0.0047007	0.2131586	0.02	0.982	0.4328424
Market trends	0.0989917	0.0781714	1.27	0.211	0.2560036
Payment by consumers	-0.0064162	0.003018	-2.13	0.038 **	-0.0003543
Consumers	-0.0255346	0.0726553	-0.35	0.727	0.1203979
Production cost	0.0257713	0.0725378	0.36	0.724	0.1714678
Total number of children by participants	0.3940138	0.226709	1.74	0.088 *	0.8493723
Age of the participants	0.2337287	0.1220305	1.92	0.061 *	0.4788343
Consumption patterns	3.156138	0.9300637	3.39	0.001 ***	5.024226
/sigma	0.7798788	0.0779147			0.936375
Number of obs	79				
LR chi ²	56.55				
Prob > chi ²	0.0000				
Pseudo R ²	0.272				
Log likelihood	75.592938				

Note: ***, ** and * indicates 1%, 5% and 10% levels of significance, respectively.

There is a negative coefficient (-0.6160918), and 1% significant level of relationship between experience and the income level among the participants. This simply articulates that the higher the

years of experience the lower the income and vice versa. This is contrary to the a priori expectation of the study. Ordinarily, it is expected that the higher years of experience should lead to more income, because the participants should have acquired more experience in production and marketing which should have translated into increased income. However, this outcome might be peculiar to the study area; maybe the experiences acquired by the participants were not on the herbal cosmeceuticals, thereby negatively affecting their income from the herbal-based cosmetics and cosmeceuticals in the study area.

The religious affiliation variable of the participants has a negative coefficient (-0.6951942) and was significant at the 5% level of significance with the income level of the participants. This means that religious affiliation has a negative and significant relationship or contribution to the income from herbal-based cosmetics and cosmeceuticals. The results of the study are aligned with the previous studies (Bettendorf and Dijkgraaf 2011; Öhlmann and Hüttel 2018). These aforementioned authors opined that religious affiliation had a negative effect in the low-income and medium income countries such as South Africa.

The estimate for the expenditure of the participants was statistically significant at 1% level with a positive coefficient (0.6121074), indicating that the expenditure level of the participants stimulated an increase in their income level. As highlighted by Janvry and Sadoulet (De Janvry and Sadoulet 2001), education, gender and year of experience contribute a vital role in determining the income of the participants. This stands to corroborate the basic economic rule of income and expenditure that the more the income level of an individual the more the expenditure of such individual.

In addition, social grants have become an increasingly popular means of improving the welfare of poor households in South Africa (Satumba et al. 2017; Biyase). Social Assistance Act of 2004 provides the legal framework for the administration of social grants. One of the frameworks is that teenagers are targeted as categories of people who are vulnerable to poverty and in need of state support. In households where there are teenagers, it is applicable that they receive social grants. The coefficient of the participants' accessibility to social grants shows that it was statistically positive (0.041) and significant at a 5% level. This means that the participants whose children benefit from the monthly social grant have more income than their contemporaries whose children do not benefit from the grant. This is in line with the expected outcome of this research, as households with more social grants are expected to have more income (Nedombeloni and Oyekale 2015).

The study further showed that payment by consumers had a negative (-0.0064162) relationship and was significant at the 5% level of statistical significance with the participants' income level. This means that the payment by consumers did not have a significant relationship with income. It suggest that the participants relied on social grants as a source of income (Nedombeloni and Oyekale 2015). In the study area, "*Vhavenda aba badale*", meaning that 'Vhavenda people do not pay' is a common phrase that is well-known among the participants. The assumption is that herbal-based cosmetics and cosmeceuticals are undermined because of lack of packaging and branding, so the consumers are not willing to pay. According to Zekiri and Hasani (2015), good packaging helps to identify and differentiate products to the consumers.

The coefficient of the total number of children by the participants was found to be positive (1.05755) and significant at a 10% level of statistical significance. This means that the number of children per household remained a key factor for bringing more income for the participants. It stands to support what was earlier discussed (concerning teenagers), that there is a positive relationship between the overall figures of children in each household income. The age parameter of the participants was also found to be positive (0.2337287) and significant at a 10% level of significance. This means that the age of the participants is related to their income level. This could probably be due to the fact that when people age they acquire more knowledge about herbal cosmetic production, hence more income. This factor was also highlighted by Adelekan and Omotayo (2017). The authors indicated that age was statistically significant to the productivity and income of farmers.

The Tobit regression fitted coefficient for consumption patterns of herbal-based cosmetics and cosmeceuticals was statistically positive (0.0257713) and significant at a 1% level of significance on the income of the participants. This indicates that the consumption rate of the participants increases with an increase in their income level. This actually validates the a priori knowledge that the consumption of individuals increases with income level (Burger et al. 2015). As highlighted by Brück (2001), income and consumption assess several dimensions of welfare; this observation aligned with the results on the current study. On the other hand, education and consumption are determinants of welfare (Celik and Hotchkiss 2000).

4.3. Budgeting Analysis of the Response by the Participants

Gross margin was used to estimate the cost and return on herbal-based cosmetic and cosmeceutical production in the study area as presented thus: $GM = TR - TVC$

$$\text{Benefit cost ratio (BCR)} = \frac{TR}{TC}$$

$$TC = TFC + TVC$$

where: TC = total cost, TR = total revenue, TC = total cost, TR = total revenue, TFC = total fixed cost, TVC = total variable cost, GM = gross margin:

$$TR = 107.37 \text{ USD}$$

$$TVC = 53.94 \text{ USD}$$

$$TFC = 30.54 \text{ USD}$$

$$TC = 83.89 \text{ USD}$$

$$GM = 107.37 \text{ USD} - 83.89 \text{ USD} = 23.64 \text{ USD}$$

$$BCR = \frac{R1841.01 (107.37 \text{ USD})}{R1438.42 (83.89 \text{ USD})} = 1.28 (0.075 \text{ USD})$$

Note: USD 1 = 17.03 South African rand.

Gross margin analysis was utilized to gauge the expense and profit of herbal-based cosmetic and cosmeceutical production in the study area. Thus, the benefit cost ratio (BCR) was 1.28 (0.073 USD). By implication, given that the BCR is greater than 1, it suggests that herbal-based cosmetic and cosmeceutical production is lucrative in Vhembe District Municipality of Limpopo Province, South Africa. This implies that for every R1.00 (0.057 USD) invested in herbal-based cosmetic and cosmeceutical production in the study area, an expected return of R1.28 (0.073 USD) return will be realised ceteris paribus. The profitability of herbal-based cosmetic and cosmeceutical enterprise is expected to increase significantly if more capital is ploughed into its production. As indicated by Ladzani and Netswera (2009), skills development enhances the labour force participation in an economy, as it assists in reducing unemployment, inequality and poverty that continues to be essential challenges in rural areas. Although some support institutions/agencies are currently in place, the awareness is relatively low among emerging rural entrepreneurs. Thus, government and other support agencies need to intensify efforts to raise the awareness and promotion, especially for herbal-based cosmetic and cosmeceutical production in local areas (Rampedi 2010).

5. Conclusions

The current findings established the link between the environmentally endowed herbal-based cosmetics and cosmeceuticals and the welfare of the Vhavenda women in Vhembe District Municipality. The majority of the participants were over 60 years old, which is an indication that the

knowledge is held by the older generation. Educational attainment was found to be the key significant variable in the descriptive and inferential model statistics, which implies that formal education should be strongly encouraged as a means to improve their livelihood. Variables such as years of experience in herbal-based cosmetics and cosmeceuticals, expenditure levels of the participants, teenagers in the household, total number of children by participants, age of the participants, and consumption patterns were the socio-economic independent variables that were statistically significant to income level from herbal-based cosmetics and cosmeceuticals. A budgeting cost ratio indicates that for every R1.00 (0.057 USD) invested in the herbal-based cosmetic and cosmeceutical production, an expected return of R1.28 (0.073 USD) was realised. However, the study excluded the discount rate and time range in budgeting analysis (benefit cost ratio) due to the limited duration (1 year) of the research. Taken together, these findings serve as inputs for the evidence-based policy interventions to promote herbal-based cosmetics and cosmeceuticals as well as radical socio-economic transformation, particularly in the study area. The policy makers should encourage the youth in rural communities by implementing policies and providing incentives that will make herbal-based cosmetics and cosmeceuticals more lucrative. In addition, an in-depth inventory of herbal-based cosmetics and cosmeceuticals with associated economic potential should be taken with a more deliberate effort by the government, researchers and non-governmental organizations. This may be facilitated by increased funding and active promotion of herbal-based cosmetics and cosmeceuticals enterprise in the region.

Author Contributions: Conceptualization, P.T.N., A.O.O., A.O.A. and W.O.-M.; Formal analysis, P.T.N. and O.A.; Funding acquisition, W.O.-M.; Investigation, P.T.N.; Project administration, W.O.-M.; Resources, W.O.-M.; Supervision, W.O.-M.; Validation, A.O.A.; Writing—original draft, P.T.N.; Writing review and editing, A.O.O., A.O.A. and W.O.-M. All authors have read and agreed to the published this version of the manuscript.

Funding: This research was funded by the National Research Foundation, Pretoria, South Africa (grant number: UID 105161). The Article Processing Charge (APC) was funded by the Faculty of Natural and Agricultural Sciences, North-West University, South Africa.

Acknowledgments: We are grateful to all the knowledge holders in selected villages of Vhembe District Municipality who willingly participated in the project. We thank Nkhanyseni Thukutha and Luesani Tshikovha (research assistants) for their great contribution during the field work.

Conflicts of Interest: The authors declare no conflict of interest.

References

- Adelekan, Yinka Adetunji, and Abiodun Olusola Omotayo. 2017. Linkage between rural non-farm income and agricultural productivity in Nigeria: A tobit-two-stage least square regression approach. *Journal of Developing Areas* 51: 317–33. [[CrossRef](#)]
- Ahmad, Mushtaq, Mir Ajab Khan, and Muhammad Zafar. 2008. Traditional herbal cosmetics used by local women communities in district Attock of Northern Pakistan. *Indian Journal of Traditional Knowledge* 7: 421–24.
- Alves, Rômulo R. N., and Ierecê M. L. Rosa. 2007. Biodiversity, traditional medicine and public health: Where do they meet? *Journal of Ethnobiology and Ethnomedicine* 3: 14. [[CrossRef](#)] [[PubMed](#)]
- Amit, Jain, Dubey Subodh, Gupta Alka, Kannoja Pushpendra, and Tomar Vivek. 2010. Potential of herbs as cosmaceuticals. *International Journal of Research in Ayurveda and Pharmacy* 1: 71–77.
- Anang, Benjamin Tetteh, and Richard W. N. Yeboah. 2019. Determinants of off-farm income among smallholder rice farmers in Northern Ghana: Application of a double-hurdle model. *Hindawi Advances in Agriculture*. [[CrossRef](#)]
- Antignac, Eric, Gerhard J. Nohynek, Thomas Re, Jacques Clouzeau, and Hervé Toutain. 2011. Safety of botanical ingredients in personal care products/cosmetics. *Journal of Food and Chemical Toxicology* 49: 324–41. [[CrossRef](#)] [[PubMed](#)]
- Arthur, Jones Lewis. 2005. *Family Size and It's Socio-Economic Implications in the Sunyani Municipality of the Brong Ahafo Region of Ghana*. Cape Coast: University of Cape Coast.
- Awotide, B. A., T. Abdoulaye, A. Alene, and Victor M. 2019. Socio-economic factors and smallholder cassava farmers' access to credit in south-western Nigeria. *Tropicicultura* 37. [[CrossRef](#)]

- Beltreschi, Leticia, Rita Baltazar de Lima, and Denise Dias da Cruz. 2018. Traditional botanical knowledge of medicinal plants in a “quilombola” community in the Atlantic Forest of northeastern Brazil. *Environment, Development and Sustainability* 21: 1185–203. [CrossRef]
- Bettendorf, Leon, and Elbert Dijkgraaf. 2011. The bicausal relation between religion and income. *Journal of Applied Economics* 43: 1351–63. [CrossRef]
- Bilal, Arebu I., Zelalem Tilahun, Tariku Shimels, Yewubdar B. Gelan, and Ebrahim D. Osman. 2016. Cosmetics utilization practice in Jigjiga town, Eastern Ethiopia: A community based cross-sectional study. *Journal of Cosmetics* 3: 40. [CrossRef]
- Biyase, Mduzuzi. 2018. *Assessing the Impact of Social Grants on Household Welfare Using Morning after Simulation and PSM Approach*. Munich: University Library of Munich, vol. 1, pp. 1–17.
- Booker, Anthony James. 2014. *The Transformation of Traditional Asian Medical Knowledge into International Commodities—The Link between Traditional Medicines and the International Market*. London: UCL University College London.
- Botha, Jenny, E. T. F. Witkowski, and Charlie M. Shackleton. 2004. Market profiles and trade in medicinal plants in the Lowveld, South Africa. *Environmental Conservation* 31: 38–46. [CrossRef]
- Brück, Tilman. 2001. *Determinants of Rural Poverty in Post-War Mozambique: Evidence from a Household Survey and Implications for Government and Donor Policy*. QEH Working Paper Series—QEHWPS67; Oxford: Queen Elizabeth House, University of Oxford, pp. 1–67.
- Burger, Ronelle, Megan Louw, Brigitte Barbara Isabel de Oliveira Pegado, and Servaas van der Berg. 2015. Understanding consumption patterns of the established and emerging South African black middle class. *Journal of Development Southern Africa* 32: 41–56. [CrossRef]
- Butler, Mark S., Avril AB Robertson, and Matthew A. Cooper. 2014. Natural product and natural product derived drugs in clinical trials. *Natural Product Reports* 31: 1612–61. [CrossRef] [PubMed]
- Cameron, Roslyn, and Jennifer L. Harrison. 2012. The interrelatedness of formal, non-formal and informal learning: Evidence from labour market program participants. *Australian Journal of Adult Learning* 52: 277–309.
- Celik, Yusuf, and David R. Hotchkiss. 2000. The socio-economic determinants of maternal health care utilization in Turkey. *Social Science and Medicine* 50: 1797–806. [CrossRef]
- Chaudhri, S. K., and N. K. Jain. 2014. History of cosmetics. *Asian Journal of Pharmaceutics (AJP)* 3: 1–4.
- Daud, S. A., A. O. Omotayo, A. O. Aremu, and A. B. Omotoso. 2018. Rural infrastructure and profitability of food crop production in oyo state, Nigeria. *Applied Ecology and Environmental Research* 16: 4655–65. [CrossRef]
- De Janvry, Alain, and Elisabeth Sadoulet. 2001. Income strategies among rural households in Mexico: The role of off-farm activities. *World Development* 29: 467–80. [CrossRef]
- Delpuech, Francis, Pierre Traissac, Yves Martin-Prével, J. P. Massamba, and Bernard Maire. 1999. Economic crisis and malnutrition: Socioeconomic determinants of anthropometric status of preschool children and their mothers in an African urban area. *Public Health Nutrition* 3: 39–47. [CrossRef]
- Freeman, H. Ade, Simeon K. Ehui, and Mohammad A. Jabbar. 1998. Credit constraints and smallholder dairy production in the East African Highlands: Application of a switching regression model. *Journal of Agricultural Economics* 19: 33–44. [CrossRef]
- Jeelani, Syed Mudassir, Gulzar A. Rather, Arti Sharma, and Surrinder K. Lattoo. 2017. In perspective: Potential medicinal plant resources of Kashmir Himalayas, their domestication and cultivation for commercial exploitation. *Journal of Applied Research on Medicinal and Aromatic Plants* 8: 1–16. [CrossRef]
- Kyei, Kwabena A. 2011. Some socio-economic indicators from Vhembe District in Limpopo Province in South Africa. *Journal of Emerging Trends in Economics and Management Sciences* 5: 364–71.
- Ladzani, Watson, and Godfrey Netswera. 2009. Support for rural small businesses in Limpopo Province, South Africa. *Development Southern Africa* 26: 225–39. [CrossRef]
- Lall, Namrita, and Navneet Kishore. 2014. Are plants used for skin care in South Africa fully explored? *Journal of Ethnopharmacology* 153: 61–84. [CrossRef]
- Lawal, Ibraheem Oduola, Ikeolu Idowu Olufade, Basirat Olabisi Rafiu, and Adeyemi O. Aremu. 2020. Ethnobotanical survey of plants used for treating cough associated with respiratory conditions in Ede South local government area of Osun State, Nigeria. *Plants* 9: 647. [CrossRef] [PubMed]

- Mafimisebi, Taiwo Ejiola, Adegboyega E. Oguntade, Ajibefun Ia, Ojuotimi Mafimisebi, and Ikuemonisan Es. 2013. The Expanding Market for Herbal, Medicinal and Aromatic Plants In Nigeria and the International Scene. *Medicinal & Aromat Plants*. [CrossRef]
- Mahomoodally, M. Fawzi, and Poorneeka Ramjuttun. 2016. A quantitative ethnobotanical survey of phytocosmetics used in the tropical island of Mauritius. *Journal of Ethnopharmacology* 193: 45–59. [CrossRef] [PubMed]
- Makunga, N. P., Anna Katharina Jäger, and Johannes Van Staden. 2008. Contribution of South African plants to medicinal plant biotechnology. *South African Journal of Botany* 74: 372. [CrossRef]
- Mander, Myles, Lungile Ntuli, Nicci Diederichs, and Khulile Mavundla. 2007. Economics of the traditional medicine trade in South Africa: Health care delivery. *South African Health Review* 2007: 189–96.
- Mansor, Norudin, Desnika Efni Binti Mat Ali, and Mohd Rafi Yaacob. 2010. Cosmetic usage in Malaysia: Understanding of the major determinants affecting the users. *International Journal of Business and Social Science* 1: 273–81.
- Ndayambaje, Jean Damascene, Wim J. M. Heijman, and G. M. J. Mohren. 2012. Household determinants of tree planting on farms in rural Rwanda. *Small-Scale Forestry* 11: 477–508. [CrossRef]
- Ndhlovu, P. T., O. Mooki, W. Otang Mbeng, and A. O. Aremu. 2019. Plant species used for cosmetic and cosmeceutical purposes by the Vhembe women in Vhembe District Municipality, Limpopo, South Africa. *South African Journal of Botany* 122: 422–31. [CrossRef]
- Nedombeloni, Rachel, and Abayomi Samuel Oyekale. 2015. Welfare impacts of social grants in Thulamela local municipality of Limpopo province, South Africa. *Journal for Theory and Practice of Socio-Economic Development* 4: 1–22. [CrossRef]
- Nguyen, Hung Manh, and Tuan Anh Nguyen. 2019. Investigating the determinants of household welfare in the Central Highland, Vietnam. *Cogent Economics & Finance* 7: 1684179. [CrossRef]
- Nhemachena, Charles, S. Jonas, and S. Karuaihe. 2015. Understanding of the current practices, challenges and opportunities of the green economy in Limpopo Province. *Journal of Public Administration* 50: 6–31.
- Nmadu, Job N., Halima Sallawu, and Busayo V. Omojeso. 2015. Socio-economic factors affecting adoption of innovations by cocoa farmers in Ondo state, Nigeria. *Journal of European Business and Economics and Accountancy* 3: 58.
- Noorhosseini, Seyyed Ali, Esmaeil Fallahi, and Christos A. Damalas. 2019. Promoting cultivation of medicinal and aromatic plants for natural resource management and livelihood enhancement in Iran. *Environment, Development and Sustainability* 22: 1–18. [CrossRef]
- Ntuli, Herbert, and Edwin Muchapondwa. 2017. Effects of wildlife resources on community welfare in Southern Africa. *Journal of Ecological Economics* 131: 572–83. [CrossRef]
- Öhlmann, Philipp, and Silke Hüttel. 2018. Religiosity and household income in Sekhukhune. *Journal of Development Southern Africa* 35: 179–93. [CrossRef]
- Ojimba, Thankgod Peter. 2013. Socio-demographic factors as determinants of poverty in crude oil polluted crop farms in Rivers State, Nigeria. *International Journal of Food and Agricultural Economics* 1: 13–25.
- Organisation of Economic and Co-Operation Development (OECD). 2018. Working Age Population (Indicator). Available online: <https://data.oecd.org/pop/working-age-population.htm> (accessed on 30 May 2018).
- Rampedi, Isaac Tebogo. 2010. *Indigenous Plants in the Limpopo Province: Potential for Their Commercial Beverage Production*. Pretoria: University of South Africa.
- Rampedi, Isaac T., and Jana Olivier. 2013. Traditional beverages derived from wild food plant species in the Vhembe District, Limpopo Province in South Africa. *Journal of Ecology of food nutrition* 52: 203–22. [CrossRef]
- Ross, Kimberly Bernita. 2017. *Traditional Terrain: Land, Gender, and Cultural Biodiversity Preservation in Venda, South Africa*. East Lansing: Michigan State University.
- Satumba, Takunda, Amienna Bayat, and Seeraj Mohamed. 2017. The impact of social grants on poverty reduction in South Africa. *Journal of Economics* 8: 33–49. [CrossRef]
- Sekhampu, Tshediso Joseph. 2012. Socio-economic determinants of household food expenditure in a low income township in South Africa. *Mediterranean Journal of Social Sciences* 3: 449–53.
- Shackleton, Charlie M., Sheona E. Shackleton, Erik Buiten, and Neil Bird. 2007. The importance of dry woodlands and forests in rural livelihoods and poverty alleviation in South Africa. *Forest Policy and Economics* 9: 558–77. [CrossRef]
- Statistics South Africa. 2012. *Census 2011 Statistical Release*. Pretoria: Statistics South Africa.

- Statistics South Africa. 2018. *Quarterly Labour Force Survey*. Pretoria: Statistics South Africa, pp. 1–131.
- Thondhlana, Gladman, and Edwin Muchapondwa. 2014. Dependence on environmental resources and implications for household welfare: Evidence from the Kalahari drylands, South Africa. *Journal of Ecological Economics* 108: 59–67. [CrossRef]
- Tobin, James. 1958. Estimation of relationships for limited dependent variables. *Econometrica* 26: 24–36. [CrossRef]
- Tongco, Ma Dolores C. 2007. Purposive sampling as a tool for informant selection. *Ethnobotany Research and Applications* 5: 147–58. [CrossRef]
- Van Wyk, B.en-Erik. 2011. The potential of South African plants in the development of new food and beverage products. *South African Journal of Botany* 77: 857–68. [CrossRef]
- Van Wyk, Ben-Erik. 2015. A review of commercially important African medicinal plants. *Journal of Ethnopharmacology* 176: 118–34. [CrossRef]
- Vhembe District Municipality. 2016. *Intergrated Development Plan Review; 2016/17*. IDP. p. 432.
- Williams, Vivienne L., Ed TF Witkowski, and Kevin Balkwill. 2007. Volume and financial value of species traded in the medicinal plant markets of Gauteng, South Africa. *International Journal of Sustainable Development and World Ecology* 14: 584–603. [CrossRef]
- Zekiri, Jusuf, and Vjollca Visoka Hasani. 2015. The role and impact of the packaging effect on consumer buying behaviour. *Journal of Ecoforum* 4: 232–40.



© 2020 by the authors. Licensee MDPI, Basel, Switzerland. This article is an open access article distributed under the terms and conditions of the Creative Commons Attribution (CC BY) license (<http://creativecommons.org/licenses/by/4.0/>).

MDPI
St. Alban-Anlage 66
4052 Basel
Switzerland
Tel. +41 61 683 77 34
Fax +41 61 302 89 18
www.mdpi.com

Economies Editorial Office
E-mail: economies@mdpi.com
www.mdpi.com/journal/economies



MDPI
St. Alban-Anlage 66
4052 Basel
Switzerland

Tel: +41 61 683 77 34

www.mdpi.com



ISBN 978-3-0365-6260-5