

Zuloaga, Gonzalo; Plückebaum, Thomas

**Working Paper**

## In-building telecommunications infrastructure

WIK Working Paper, No. 5

**Provided in Cooperation with:**

WIK Wissenschaftliches Institut für Infrastruktur und Kommunikationsdienste GmbH, Bad Honnef

*Suggested Citation:* Zuloaga, Gonzalo; Plückebaum, Thomas (2022) : In-building telecommunications infrastructure, WIK Working Paper, No. 5, WIK Wissenschaftliches Institut für Infrastruktur und Kommunikationsdienste, Bad Honnef

This Version is available at:

<https://hdl.handle.net/10419/270989>

**Standard-Nutzungsbedingungen:**

Die Dokumente auf EconStor dürfen zu eigenen wissenschaftlichen Zwecken und zum Privatgebrauch gespeichert und kopiert werden.

Sie dürfen die Dokumente nicht für öffentliche oder kommerzielle Zwecke vervielfältigen, öffentlich ausstellen, öffentlich zugänglich machen, vertreiben oder anderweitig nutzen.

Sofern die Verfasser die Dokumente unter Open-Content-Lizenzen (insbesondere CC-Lizenzen) zur Verfügung gestellt haben sollten, gelten abweichend von diesen Nutzungsbedingungen die in der dort genannten Lizenz gewährten Nutzungsrechte.

**Terms of use:**

*Documents in EconStor may be saved and copied for your personal and scholarly purposes.*

*You are not to copy documents for public or commercial purposes, to exhibit the documents publicly, to make them publicly available on the internet, or to distribute or otherwise use the documents in public.*

*If the documents have been made available under an Open Content Licence (especially Creative Commons Licences), you may exercise further usage rights as specified in the indicated licence.*



# WIK

# Working Paper

No. 5

## In-Building Telecommunications Infrastructure

Gonzalo Zuloaga  
Dr. Thomas Plückebaum

*December 2022*



**WIK**

Wissenschaftliches Institut  
für Infrastruktur und  
Kommunikationsdienste

## IMPRINT

### WIK WORKING PAPERS

The working papers published in the series constitute work in progress circulated to stimulate discussion and critical comments. Views expressed represent exclusively the authors' own opinions and do not necessarily reflect those of the editor.

WIK Wissenschaftliches Institut für  
Infrastruktur und Kommunikationsdienste GmbH  
Rhöndorfer Str. 68  
53604 Bad Honnef, Germany  
E-Mail: [info@wik.org](mailto:info@wik.org)  
[www.wik.org](http://www.wik.org)

#### **Person authorised to sign on behalf of the organisation**

General Manager	Dr Cara Schwarz-Schilling
Director	Alex Kalevi Dieke
Director	
Head of Department Networks and Costs	Dr Thomas Plückebaum
Director	
Head of Department Regulation and Competition	Dr Bernd Sörries
Head of Administration	Karl-Hubert Strüver
Chairperson of the Supervisory Board	Dr Thomas Solbach
Registered at	Amtsgericht Siegburg, HRB 7043
Tax No.	222/5751/0926
VAT-ID	DE 329 763 26



## Table of content

<b>1 Introduction</b> .....	<b>3</b>
1.1 Motivation and background .....	3
1.2 Purpose of the study .....	3
<b>2 Delimitation of in-building infrastructure</b> .....	<b>4</b>
<b>3 Current situation of in-building infrastructure</b> .....	<b>6</b>
<b>4 Access to inbuilding infrastructure and competition aspects</b> .....	<b>8</b>
4.1 Legal context .....	8
4.2 Technical constraints to achieve gigabit objectives on existing in-building infrastructures.....	9
4.2.1 Copper twisted pair .....	9
4.2.2 Coaxial cable .....	16
4.2.3 Opportunities and limitations .....	23
4.3 Future-proof solutions for gigabit capable in-building infrastructures.....	24
4.3.1 Fibre optic cable .....	24
4.3.2 Passive infrastructure and the role of standardisation .....	32
4.3.3 Upgrading in-building infrastructure .....	40
4.3.4 Safety regulations on in-building cable deployment .....	41
4.3.5 Highlights.....	45
<b>5 Summary and conclusions</b> .....	<b>46</b>
<b>Literature</b> .....	<b>47</b>
<b>Annex</b> .....	<b>51</b>

## List of Figures

Figure 2-1:	Delimitations of network levels and in-building infrastructure .....	4
Figure 4-1:	G.fast distribution point unit (DPU) and building entry unit (BEP) .....	11
Figure 4-2:	Typical in-building cabling structures for multi-dwelling buildings .....	12
Figure 4-3:	Copper twisted pairs with and without shielding and ‘cross-talk’ .....	13
Figure 4-4:	Technical issues of upgrading (from FTTC to FTTB) a single apartment in a multi-dwelling unit using the same in-building copper cables .....	15
Figure 4-5:	DOCSIS 3.1 and DOCSIS 4.0 – Individual transmission speeds for end users for different fibre-node sizes (at busy hour = 20% simultaneity) .....	18
Figure 4-6:	Typical in-building cabling structures in multi-dwelling units in Germany .....	19
Figure 4-7:	MoCA 2.5 extended band D frequency plan .....	21
Figure 4-8:	Multimedia over Coax Alliance (MoCA) access .....	22
Figure 4-9:	Reference models for FTTH PtP and PtMP within the building .....	25
Figure 4-10:	Ethernet over Fibre and x.PON series – Individual transmission speeds for end users in different splitting ratios (at busy hour = 20% simultaneity) .....	27
Figure 4-11:	Challenges of sharing and unbundling in Point-to-Multipoint (PtMP) network architectures with passive optical splitters in a cascade form .....	30
Figure 4-12:	Cable ducts and micro ducts .....	33
Figure 4-13:	Cable trunks and trays .....	34
Figure 4-14:	Overview of cable trunking and ducting systems .....	37
Figure 4-15:	Fibre cable connectors .....	39
Figure 4-16:	Flammability and Euronorm classification .....	43
Figure 0-1:	‘Tree structure’ solutions for inhouse-cabling .....	52
Figure 0-2:	‘Star structure’ solutions for inhouse cabling .....	53

## List of Tables

Table 4-1:	Gigabit capable copper-based transmission technologies .....	10
Table 4-2:	Overview of the relevant international standards for in-building passive infrastructure for cable, connectors and cable pathways .....	35
Table 4-3:	ISO/IEC 11801: channel classes and their corresponding cable and connector categories .....	36

# **1 Introduction**

## **1.1 Motivation and background**

The newly passed German telecommunication regulation (§145 TKG) has set the deployment and sharing conditions of in-building infrastructure with the purpose of addressing the need of generating proper incentives to network operators to invest in and extend their very high capacity access networks. At the same time, this should help reducing the gap of gigabit speeds reaching end user's buildings door step but not their actual homes.

While this regulation is still in early stages for an end-to-end impact analysis, this paper analyses relevant technical aspects of deploying and sharing in-building infrastructures. Particularly, we address, from a technical perspective, the requirements that different transmission technologies have on different in-building infrastructures, the opportunities and limitations on sharing in-building infrastructure, as well as the shortcomings of certain types of in-building infrastructure and topologies in achieving the gigabit objectives.

By going beyond the new regulation, this paper also assesses the role of standardisation of in-building infrastructure, in securing investments in very high capacity access networks and keeping the infrastructure adaptable to new developments in the future. In absence of binding standards, we gather a set of practical recommendations promoted by German institutions regarding the deployment of new in-building infrastructure.

By focusing on technical aspects of in-building infrastructure, and disentangle how these determine the potential of deploying and sharing in-building infrastructure, we expect to shed light on fundamental technical considerations relevant to in-building infrastructure regarding the gigabit objectives and competition.

## **1.2 Purpose of the study**

We provide an overview and technical comparison of the different in-building network installations and technologies that are predominantly available in Germany in order to assess which are capable to ensure a delivery of 1 Gbps (in down- and upstream communication) to the end user. In this context, we analyse the implications that the identified technologies have on promoting open access to the building and therefore competition among network providers.

A economic and legal assessment of this technologies and their corresponding in-building infrastructures is not scope of this paper.

## 2 Delimitation of in-building infrastructure

In-building infrastructure refers to the last two network levels in a telecommunication network:

- the 'building network' (also known as network level 4) and
- the 'home network' (also known as network level 5).

The 'building network' starts with the 'building entry point' (BEP), which is a telecommunications box provided by the operator and usually located at the subscriber's basement (see Figure 2-1).<sup>1</sup> This focal point terminates the drop cable of the operator's access network.<sup>2</sup> Here, the 'building distributor' (BD) is installed, from which indoor cables are directed to the 'floor distributor' (FD)<sup>3</sup> to connect the individual apartments.

Figure 2-1: Delimitations of network levels and in-building infrastructure

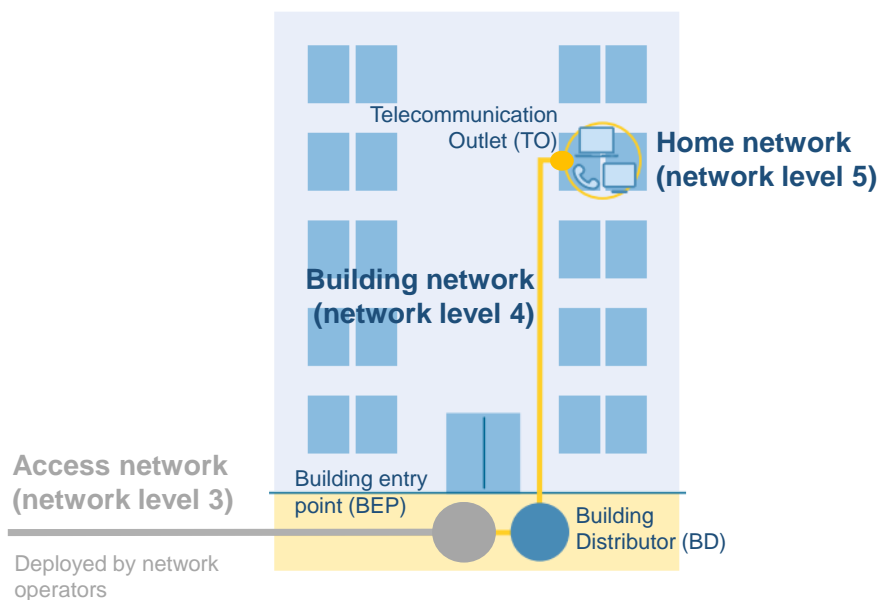

Quelle: WIK auf Basis von Gigital Netze (2020): Leitfaden zur Errichtung von Glasfaser-gebäudenetzen, p.7.

Each individual apartment has a 'telecommunication outlet' (TO), which receives and spreads the signal within the subscriber's apartment. The network within each subscriber's apartment is the 'home-network'. Here, the 'customer premises equipment' are connected.

- <sup>1</sup> In practise, in multi-dwelling units, some network providers, i.e. Deutsche Telekom, may integrate the building-entry-point (BEP) with the building distributor (BD) in one single box, known as 'Onebox' (DTAG, 2020. 'Glasfaser Wohnungswirtschaft Stuttgart'. Last accessed: 18.11.2022; BMVI, 2021. 'Bausteine für Netzinfrastrukturen von Gebäuden', p. 36).
- <sup>2</sup> BEP is then the interface between the drop cable and the in-building network. It allows the transition from outdoor to indoor cable (FTTH Council Europe (2018). FTTH Handbook Edition 8. D&O Committee. Revision Date: 13/02/2018, p.65).
- <sup>3</sup> 'Floor distributors' may be merged with the building distributor for small buildings (Batura, O., Plückebaum, T. and Wisser, M., 2018. 'Study on Implementing and monitoring of measures under Directive 61/2014 (Cost Reduction Directive) – SMART 2015/0066, p. 233).

In **single** or **two family dwellings**, the 'building-network' (network level 4) can be omitted. Then, the 'building entry point' (BEP) is directly connected with the 'telecommunication outlet' TO.<sup>4</sup>

In **multi-dwelling** properties, which account for 52% of the households in Germany,<sup>5</sup> the 'building-network' (network level 4) represents a substantial part of the inhouse-cabling infrastructure. The interconnection of the 'building-entry-point (BEP) in the basement with the 'floor distributor' (FD) and/or the 'termination outlet' (TO) in each floor is performed by a 'riser cable'. The 'riser cable' is the most time-consuming installation part of the inhouse-infrastructure, especially due to safety regulations, as they often pass stairways used as escape routes (see Section 4.3.4).<sup>6</sup>

From the access network's MPoP up to the network termination point within the building, or 'building entry point' (BEP) all network elements are installed by the network operator, whereas the inhouse infrastructure (that is the 'building-network' and 'home-network') is to a greater extent the responsibility of the owner(s).

---

<sup>4</sup> Digital Netze (2020). ‚Leitfaden zur Errichtung von Glasfasergebäudenetzen‘, p. 7.

<sup>5</sup> Share of residential units in multi-family dwellings to the overall number of residential units. The number of residential units ('Wohnungen') is taken from Statistisches Bundesamt (Destatis) 2022: 'Anzahl der Wohnungen'. Stand: 27.01.2022. Code: 31231-0001.

<sup>6</sup> FTTH Council Europe (2018). FTTH Handbook Edition 8. D&O Committee. Revision Date: 13/02/2018, p.67.



### 3 Current situation of in-building infrastructure

The in-building infrastructure consists of indoor cables and their corresponding cabling pathways. In general, the type of cables used within the building will determine primarily what broadband speed and applications can be used. The major types of cables that are used within the building are: twisted copper pair, coaxial cables and fibre optic cable.

Twisted copper pair was originally deployed for analogue transmission of a telephone signals (3,6 kHz) and not for high-frequency and broadband transmission. Yet, they currently account for more than 70% of active inhouse-cabling's connections in Germany.<sup>7 8</sup>

VDSL ('Very High Speed Digital Subscriber Line') is an asymmetric copper-pair-based transmission technology. Its successor, VDSL2, it's the one prevailing in Germany. With the introduction of 'Vectoring' techniques,<sup>9</sup> this transmission technology has been formally extended to reach data transmission rates of up to 100 Mbps (and 250 Mbps with 'SuperVectoring') in environments with relatively short connection lines.<sup>10</sup> Although widely available in Germany (approx. 80% homes-passed)<sup>11</sup>, this copper-based transmission technology is not capable of delivering at least 1 Gbps to the end-user.

Coaxial cables are another form of copper cables, dedicated for the transmission of high frequency signals over short distances. They were originally developed to transmit unidirectional TV broadcasts over cable networks decades ago. With the introduction of the transmission protocol DOCSIS ('Data over Cable Service Interface Specification'), the establishment of individual bidirectional communication over coaxial cables became possible. Over time, with newer DOCSIS releases, and the far reaching cable TV infrastructure, this transmission technology has become increasingly popular, accounting today for roughly 70% of 'homes-passed'<sup>12</sup> and 25% of 'homes-activated'<sup>13</sup> in Germany.

In the 1990s, Deutsche Telekom introduced the use of fibre optic cables in access networks for the first time, especially in eastern Germany, when restoring and enhancing the sparsely

---

<sup>7</sup> DSL (20,3%), VDSL (48,5%), FTTB (2,4%) see Bundesnetzagentur (2021). 'Jahresbericht 2021', pp. 51-65.

<sup>8</sup> While the copper telephone wires are typically unshielded (UTP), there exists a pairwise shielded copper wire (STP) cable too, typically used in business environments for more than 40 years and with increasing importance in residential buildings as well. The shield prevents crosstalk among the copper pairs in a wire bundle, giving each pair a single wire pair condition (see section 4.2.1).

<sup>9</sup> Standard ITU-T G.993.5.

<sup>10</sup> In order to reduce the typical interference in copper unshielded twisted pairs and achieve the above mentioned data rates, Vectoring requires all subscriber lines to be connected to the same DSLAM (Elektronik-Kompendium.de, 2022. 'VDSL2-Vectoring / ITU-T G.993.5 / G.vector'. <https://www.elektronik-kompendium.de/sites/kom/1804231.htm>. Last accessed: 06.10.2022).

<sup>11</sup> Available for 33 million households in Germany, see European Commission (2021). 'Broadband Coverage in Europe 2021'. <https://digital-strategy.ec.europa.eu/en/policies/desi-connectivity>. Final dataset (.xlsx). Last accessed: 06.10.2021.

<sup>12</sup> Available for 28 million households in Germany, see European Commission (2021). 'Broadband Coverage in Europe 2021'. <https://digital-strategy.ec.europa.eu/en/policies/desi-connectivity>. Final dataset (.xlsx). Last accessed: 06.10.2021.

<sup>13</sup> 8,8 million active hybrid-fibre-coax (HFC) connections, see Bundesnetzagentur (2021). 'Jahresbericht 2021', p. 51.

meshed old telephone network of the former GDR, which connected some 20% of the households only.<sup>14</sup> In 1994 ISIS Multimedia Net and NetCologne, the two first City Carriers in Germany, had been founded and started business based on fibre links for business and residential customers. In 2021 Fibre-to-the-Home (FTTH) is currently available for 15% of the homes ('homes passed')<sup>15</sup> and used by only 5% of the homes ('homes activated').<sup>16</sup> Similarly, Fibre-to-the-Building (FTTB), where the network operator deploys fibre to the door of this customer, accounts for 8% of 'homes passed'<sup>17</sup> and 2% of 'homes activated'.<sup>18,19</sup>

---

<sup>14</sup> see OPAL: Optische Anschlussleitung (Sawall, A., 2020. 50 Jahre Glasfaser. Warum der erste Glasfaserausbau der Telekom scheiterte. Golem Media GmbH. 10.Dezember 2020. <https://www.golem.de/news/50-jahre-glasfaser-warum-der-erste-glasfaserausbau-der-telekom-scheiterte-2012-152748.html>. Last accessed: 22.08.2022).

<sup>15</sup> Available for 6,4 million households in Germany, see European Commission (2021). 'Broadband Coverage in Europe 2021'. <https://digital-strategy.ec.europa.eu/en/policies/desi-connectivity>. Final dataset (.xlsx). Last accessed: 25.11.2021.

<sup>16</sup> 1,7 million active FTTH connections (estimation for the year 2021), see Bundesnetzagentur (2021). 'Jahresbericht 2021', p. 56.

<sup>17</sup> Available for 2,5 million households in Germany (calculated from abstracting the 6,4 million FTTH connections from the total 8,9 million FTTH/B connections – see Bundesnetzagentur (2021). 'Jahresbericht 2021', p. 56).

<sup>18</sup> 0,9 million active FTTB connections (see Bundesnetzagentur (2021). 'Jahresbericht 2021', p. 56).

<sup>19</sup> For single-family houses, FTTH and FTTB are identical (Gigabitbüro des Bundes, 2022. 'Mehr über Gigabit Technologien erfahren'. <https://gigabitbuero.de/thema/gigabittechnologien/>. Last accessed: 29.11.2022).

## 4 Access to inbuilding infrastructure and competition aspects

In order for end users to receive a competitive broadband connectivity service, the existing in-building infrastructure has to be made accessible to all network operators. Particularly, due to the lagged deployment of fibre cables, opening up the in-building infrastructure to all operators, is intended to incentivize investments in fibre optic access networks. In order to understand the legal rationale behind this, the newly approved regulation is revisited below.

### 4.1 Legal context

The novel German telecommunication law (*Telekommunikationsgesetz* – TKG, 2021) sets in §145 the specifications and conditions for the deployment new in-building network infrastructure (see paragraphs 1, 4 and 5) as well as the permission requirements for sharing the existing in-building network infrastructure (see paragraphs 2, 3 and 8).

#### Deployment of new in-building network infrastructure

According to §145 (1), network operators are allowed to extend their telecommunication networks onto the user's premises, under the following conditions:

- the end user agrees with the intervention and the collision with property rights of third parties are kept at the minimum.
- the **shared use** of existing network infrastructure according to paragraphs 2 and 3 is **not possible without** delivering telecommunication services to the end user that entailed noticeable **quality loss**.

As long as this is necessary for the network termination, the building owner is obliged to allow the telecommunications network operator to connect active network components to the electricity network upon request.

According to §145 (4) and (5), newly built or extensively renovated buildings must be equipped with **suitable** passive network infrastructure for very high capacity networks.

In this context, deploying new in-building infrastructure requires finding answers to technical questions such as, when is the shared use 'not possible without quality loss' or when are passive network infrastructures 'suitable' for very high capacity networks? These questions will be addressed in further detail throughout this paper.

#### Sharing the existing in-building network infrastructure

According to §145 (2) TKG, networks operators may apply to owners or operators of in-building components (including cabling and associated facilities) for sharing of the in-building network

infrastructure in order to terminate their network at the end-user's premises, under the following conditions:

- the duplication of the network infrastructure is **technically impossible** or economically inefficient.
- access to the building's internal infrastructure to be shared is not granted in accordance with §72 (6) TKG (Fibre provision fee – *Glasfaserbereitstellungsentgelt*).

If the criteria mentioned above are met, anyone having in-building network infrastructures must grant all reasonable requests the shared use on fair and non-discriminatory terms (including the shared use fees).

Similarly, this provision also establishes conditions on sharing in-building infrastructure. Then, when is the duplication of in-building infrastructure 'technically impossible'? Is sharing in-building infrastructure always possible? Who bears with the potential quality loss when sharing is possible? These two latter questions seem to be left out from the regulation, yet they will be also analysed in this paper.

## **4.2 Technical constraints to achieve gigabit objectives on existing in-building infrastructures**

### **4.2.1 Copper twisted pair**

With network providers expanding their fibre access networks and bringing fibre closer to the end user, more customers have optic fibre in their building's basement (Fibre-to-the-Building). Yet, in multi-dwelling units, extending fibre's gigabit speed from the basement to the end user's individual home can be challenging, as up to date the wide majority of existing buildings in Germany do not have a fibre-based in-building cabling system. Instead, they are mostly equipped with traditional old copper wires, either copper pair or coax. Typically the coaxial cables are laid in parallel to the copper telephone pairs.

### **Gigabit capable technologies on old copper wires**

In light of the prevailing importance of copper wires in existent building networks, newer generations of copper-based transmission technologies were developed to achieve significantly higher speeds: G.fast and XG.fast.<sup>20</sup>

G.fast is a copper-based DSL transmission technology with total data transmission rates up to 1 Gbps (G.fast profile 106a)<sup>21</sup> or 1,8 Gbps (G.fast profile 212a )<sup>22</sup> for short distances as rates

---

<sup>20</sup> The word 'fast' stands for 'fast access to subscriber terminals'.

<sup>21</sup> Standard ITU-T G.993.2.

<sup>22</sup> Standard ITU-T G.9700 und G.9701.

diminish rapidly as cable length grows.<sup>23</sup> These rates are available in total for both down- and upstream communication. The specification allows down- and upstream ratios to be adjustable between 90/10 and 50/50 percent.<sup>24,25</sup> This makes a gigabit connection only available in one direction (typically downstream).

Its successor, XG.fast, achieves total data transmission rates up to 10 Gbps for very short copper cable lengths up to 70 meters. Thus, symmetrical gigabit connections for down- and upstream communication of maximal 5 Gbps can be achieved within the scope of in-building distances.

Table 4-1: Gigabit capable copper-based transmission technologies

	Frequency [MHz]	Data rate [Gbps]
<b>G.Fast</b>	Up to 106 or 212 MHz	Max. 1,8 Gbps (total capacity) Max. 0,9 Gbps (symmetrically)
<b>XG.Fast</b>	Up to 350 or 500 MHz	Max. 10 Gbps (total capacity) Max. 5 Gbps (symmetrically)

Source: WIK.

Given that these technologies are able to perform on the existing old copper wires, they take advantage of the already available passive in-building infrastructure. Yet, both transmission technologies require the active equipment to be upgraded. This means exchanging the existing Modem located at the end user for the corresponding (X)G.fast Modem and installing a (X)G.fast Distribution Point Unit (DPU) in a utility closet in the building's basement.<sup>26</sup>

<sup>23</sup> Tests on a copper cable with a core cross-section of 0.5 mm<sup>2</sup> reveal that G.fast (profile 212a) loses over half of its total data transmission capacity after approx. 250 meters (Elektronik-Kompendium.de. 2022. 'G.fast / ITU-T G.9700 und G.9701'. <https://www.elektronik-kompendium.de/sites/kom/2005121.htm>. Last accessed: 18.11.2022).

<sup>24</sup> Elektronik-Kompendium.de (2022). 'G.fast / ITU-T G.9700 und G.9701'. <https://www.elektronik-kompendium.de/sites/kom/2005121.htm>. Last accessed: 18.11.2022.

<sup>25</sup> With G.Fast, both symmetrical and asymmetrical Internet access can be implemented and thus flexibly tailored to the needs of the end user (NetCologne, 2020. 'Was ist G.Fast?' Alles zur Internet-Technik. Und ihren Vorteilen. <https://www.netcologne.de/geschaeftskunden/blog/was-ist-gfast/>. Last accessed: 23.11.2022).

<sup>26</sup> The equipment requires power supply from the building. Access should only be for authorized persons (Plückebaum and Ockenfels, 2020. 'Kosten und andere Hemmnisse der Migration von Kupfer- auf Glasfasernetze'. WIK Discussion Paper Nr. 457, p.28). Even single dwellings require a (X)G.fast DPU in their basements, which means that through reserve powering, just one customer should be able to power the entire (X)G.fast DPU (Open Compute Project (2018). 'G.fast DPU Design - OCP Telecom Workshop @ BCE'. Last accessed: 18.11.2022).

Figure 4-1: G.fast distribution point unit (DPU) and building entry unit (BEP)

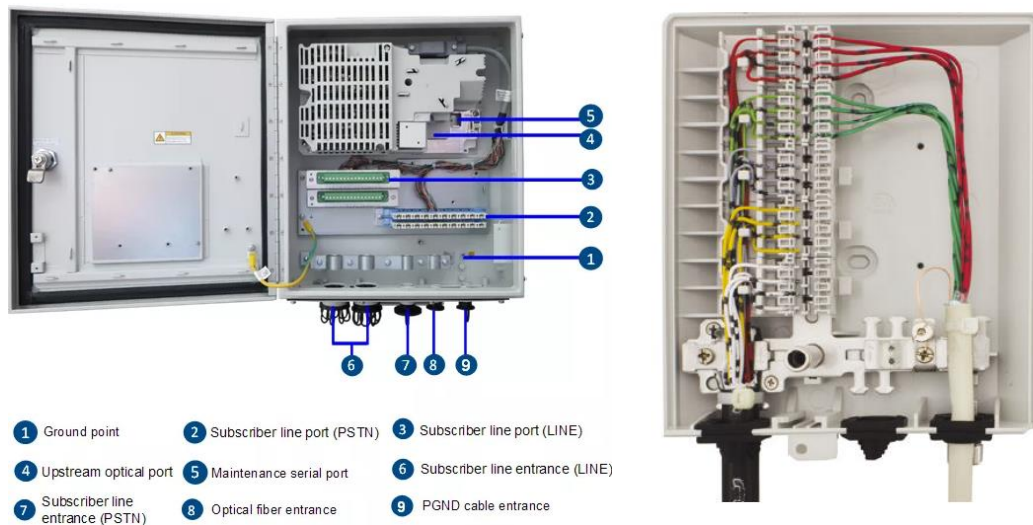

Source: G.Fast from Huawei MA5611S Optical Network Unit Huawei MDU G.fast Vectoring VDSL2 MA5611S AE08 OLT DSLAM; and BEP from TKM Telekommunikation und Elektronik GmbH (see BMVI, 2021. ‚Bausteine für Netzinfrastrukturen von Gebäuden‘, S.32).

The (X)G.fast DPU<sup>27</sup> is an active network element that must be installed and operated by the network operator, in order to be able to offer their connection services. It is usually installed in the basement next to the BEP (building-entry-point), in order to connect the incoming optic fibres with the existing copper wires gathered at the building-entry-point (BEP).<sup>28</sup> For that purpose, (X)G.fast DPU converts the incoming optical signal into electrical signals so it can be passed on to the in-building copper wires. From building-entry-point (BEP), copper pairs are merged either into a single or into several individual cables are routed up through the building’s rise area towards the respective apartment, to be then separated and connected individually to the apartment’s telecommunications outlet.<sup>29</sup>

### In-building cabling structures

Bundling the copper pairs together into a single or multi riser cable has been traditionally the preferred option for higher multi-dwelling buildings with 12 or more apartments units. This type of cabling structure is called ‘tree’ structure. Building a cabling system in a tree structure saves space and resources during the construction period, yet it places several old copper pairs very close to each other. In smaller single or multi-dwelling buildings, where more space is available and fewer apartments need to be connected, copper pairs can be routed from the building-

<sup>27</sup> The equipment will have 8 to 32 ports, or, more depending on the size of the multi-dwelling unit (VIAVI Solutions, 2018. ‘Installing G.fast in a Multi-Dwelling Unit’, p. 1).

<sup>28</sup> United Internet (2019). ‘Glasfaser-Anschlüsse: Unterschiede von FTTC, FTTB und FTTH’. Pressemitteilung vom 02.10.2019, 13:49 Uhr. <https://www.united-internet.de/investor-relations/publikationen/meldungen/meldungen-detail/news/glasfaser-anschluesse-unterschiede-von-fttc-fttb-und-ftth.html>. Last accessed: 18.11.2022.

<sup>29</sup> BMVI, 2021. ‚Bausteine für Netzinfrastrukturen von Gebäuden‘, p.32.

entry-point (BEP) in the basement through the riser directly to each apartment using individual cables. This cabling structure is known as 'star' structure.

Figure 4-2: Typical in-building cabling structures for multi-dwelling buildings

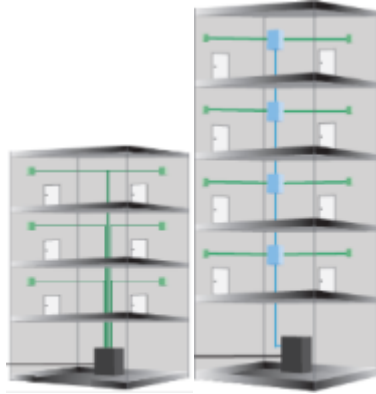

Source: Detlef Juhre (2018). 'Gebäudenetze (NE 4/5) - so gelingt der Glasfaseranschluss noch leichter'. Corning.

### Technical constraints on copper wires

At lower frequencies, i.e. used for the analogue transmission telephone signals (up to 3,4 kHz), having old copper wires running close to each other was not much a source of concern regarding transmission quality. Yet, with the substantial increase in the frequency range from ADSL to (X)G.fast (which use up to 106/212 or 500 MHz), a fundamental problem in the transmission of signals over old copper twisted pairs arises: 'cross-talk'. Due to the physical properties of copper twisted pairs, the transmission of data through electrical signals generates a magnetic field around them that act like antennas and produce the undesired electromagnetic interferences, at least to neighbouring copper pairs. Thus, the higher the frequency, the higher the number of old copper pairs, and the lower the distance between them, the higher is the mutual interference. This generates a substantial loss in the quality of signal that increasingly deteriorates throughout the entire length of the copper cable, reducing its performance.<sup>30,31</sup>

---

<sup>30</sup> 'Cross-talk' reduces the signal-to-noise ratio at the receiver enabling transmission errors to occur (Alfred Vogelsang, 2004, 'Modell für Nebensprechstörungen auf xDSL-Leitungen und dessen praktische Umsetzung', p. 20).

<sup>31</sup> Colmegna, A., Galli, S. and Goldberg, M., (2012). 'Methods for supporting vectoring when multiple services providers share the cabinet area', p.6 show that in a xDSL context (not gigabit capable technologies), when lines are properly managed (i.e. via 'dynamic spectrum management', DSM), keeping non-vectorized lines at max. data rate of 45 Mbps only reduce the speed of vectorized lines by less than 5% in 50% of cases and by 30% only in the 1 % worst case. Overall, for 99% of subscribers, vectorized lines could still achieve 100 Mbps downstream out to 300m.

'Cross-talk' among copper cables can be prevented by deploying twisted pairs with a protecting layer around them known as 'shielding'. Thus, there are typically two types of copper cables available:

- the shielded twisted pair (STP) and
- the unshielded twisted pair (UTP).

Figure 4-3: Copper twisted pairs with and without shielding and 'cross-talk'

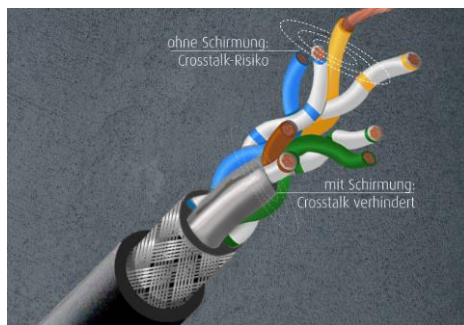

Source: CORDIAL GmbH (2022). 'Übersprechen oder Crosstalk'. <https://www.cordial-cables.com/de/uebersprechen>. Last accessed. 19.12.2022.

The shielded twisted pair (STP) protects the transmitted signal from electromagnetic interference. Nevertheless, this shielding makes the shielded twisted pair (STP) significantly thicker and more expensive than its unshielded counterpart (UTP), which has traditionally been used as the predominant technology in telecommunication networks. Apart from office or commercial buildings, there are barely residential buildings in Germany with an in-building cabling infrastructure based on shielded twisted pairs (STP).

Given that shielded twisted pairs (STP) in in-building network infrastructure is not commonly used in residential buildings in Germany, the generated 'cross-talk' can be compensated by using a correction method known as 'vectoring'. Vectoring is based on the concept of noise cancellation. It measures the interfering signals or 'noise' and reproduces the opposite or 'anti-noise' to cancel it out. These calculations require significant high performance real time computing power.

For VDSL, G.fast and XG.fast vectoring is essential, as they reach very high frequency ranges, making them particularly prone to 'cross-talk' when several copper pairs run together.<sup>32</sup> Compared to their predecessor VDSL2 Vectoring, G.fast and XG.fast apply a more complex, frequency-stepped vectoring procedure.

Vectoring has to be implemented where the bundle of copper lines can be properly measured, which is either at the DSLAM at the street cabinet or at the DPU in the building's basement. In

<sup>32</sup> NetCologne (2022). 'Was ist G.Fast?'. <https://www.netcologne.de/geschaeftskunden/blog/was-ist-gfast/>. Last accessed: 19.11.2022.



any case, vectoring only works, if the DSLAM or DPU and the copper pairs of a line bundle are controlled by a single provider. Otherwise, the calculation of the cross-talk correction between all lines is technically not possible. Leaving the interference of some lines uncanceled has significant negative impact on the signals of all other lines of the bundle, because fault correction cannot work properly.<sup>33</sup>

### **Sharing in-building infrastructure based on unshielded twisted pairs (UTP)**

In most cases, it is not efficient that each network provider deploys and runs a competing parallel in-building infrastructure to reach their customers. Not only due to costly construction works (i.e. due to local fire and building regulations), but also because there is usually neither space nor density to justify such intervention in existing buildings.

In this context, in order to reduce the costs of high-speed networks and accelerate their expansion, network providers are often granted the physical access to the existing in-building infrastructure, so that they can connect their customers to their networks, saving the cost of deploying a separate in-building network by their own. Yet, when multiple network providers share the same in-building infrastructure and attempt to deliver high frequency products through unshielded copper wires, the 'cross-talk' among wires that are run by different providers cannot be estimated, and the applied correction method 'vectoring' becomes inefficient. Signal quality for all customers sharing the same cable bundle may shrink rapidly.

This issue can be illustrated with two scenarios where at least one gigabit capable copper-based technology shares the existing in-building infrastructure with another copper based technology:

- Scenario I: one FTTB network provider at the building's basement (XG.fast), and one incumbent providing FTTC outside the building (VDSL2 Vectoring).
- Scenario II: two network FTTB providers of at the building's basement (both XG.fast).

**Scenario I.** In a given region, the incumbent 'A' runs a Fibre-to-the-Curb (FTTC) access network. Yet, some of their customers wish to upgrade their internet connection from VDSL2 Vectoring (max. 250 Mbps) to XG.fast (max. 5 Gbps symmetrical) by turning to an alternative regional network provider 'B' that has Fibre-to-the-Building (FTTB) expansion plans. If the alternative network provider installs its XG.Fast DPU in the building's basement and connects only some apartments rather than all apartments to their FTTB network, 'vectoring' fails to correct for all the 'cross-talk' generated among all the copper pairs that share the same in-building copper cable. This is because copper pairs are vectored in separate groups, which

---

<sup>33</sup> Edpnet (2022). 'What is Vectoring Technology'. <https://www.edpnet.be/en/support/installation-and-usage/internet/learn-about-dsl-configuration/what-is-vectoring-technology.html>. Last accessed: 19.11.2022.

are run by a different network providers. As a result, the uncanceled ‘cross-talk’ can cause a substantial performance loss.<sup>34</sup> Figure 4-4 depicts this scenario.

Figure 4-4: Technical issues of upgrading (from FTTC to FTTB) a single apartment in a multi-dwelling unit using the same in-building copper cables

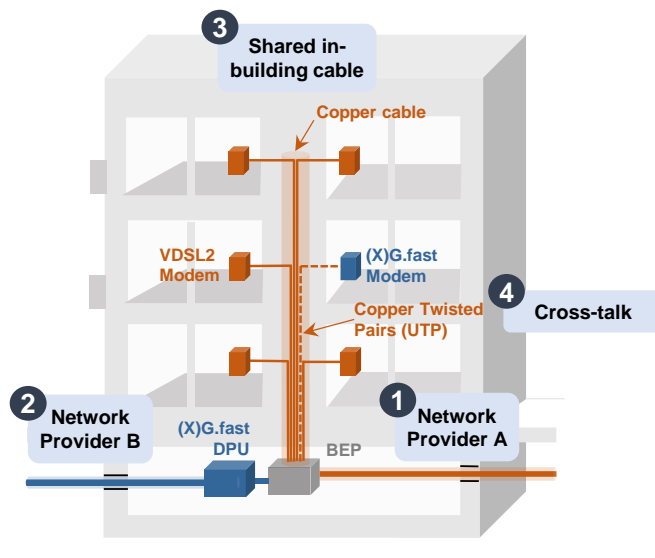

Source: WIK.

One solution is that the entire building agrees to switch completely from VDSL2 (FTTC) to (X)G.Fast (FTTB). Then, the problem of uncontrolled ‘cross-talk’ in shared in-building infrastructure is avoided, and the transmission of gigabit speeds on the existing copper cables becomes possible.

Otherwise, FTTB providers would have to be willing to forego part of the frequency that is shared with VDSL2 (up to 17 MHz or 35 MHz) in order to coexist with FTTC. As a result, the full bandwidth of the FTTB cannot be used.<sup>35</sup> According to an assessment of the German NRA in a ruling in the worst case, FTTC providers could only offer download rates from 125 to 150 Mbps, while FTTB providers would be significantly limited to 400 to 600 Mbps.<sup>36,37</sup>

<sup>34</sup> See measurements by Obermann, K. (2017). ‘Zusammenspiel von G.Fast und Supervectoring. Ist es möglich?’. BREKO Fibre conference 25.04.2017. <https://www.lwportal.de/mediathek/detail/mediathek-action/display/Item/prof-dr-kristof-obermann-gfast-und-supervectoring.html>. Last accessed: 23.11.2022

<sup>35</sup> G.fast data rate is degraded by VDSL2 35b by 5 to 6%, while for VDSL2 35b is diminished by G.fast by 4%. As soon as for G.fast only the frequency range above 35 MHz is used, both systems do not longer interfere with each other. However, this reduces the G.fast total bit rate by around 200 Mbit/s. (Bundesnetzagentur, 2020. ‘Beschluss 2. Teilentscheidung wegen der Überprüfung der Standardangebote im Zusammenhang mit der Zugangsgewährung zur Teilnehmeranschlussleitung’, öffentlicher Fassung, BK3e-15/011, pp. 178 - 180).

<sup>36</sup> Grützner, J. (2022). ‘Darf Telekom den Glasfaserausbau mittels Vectoring aushebeln?’. Entscheidung der Bundesnetzagentur zur Inhouse-Verkabelung sorgt für Verunsicherung. VATM. <https://www.vatm.de/inhouse-verkabelung/> Last accessed: 14.12.2022.

<sup>37</sup> Bundesnetzagentur (2018). ‘Beschluss 1. Teilentscheidung wegen der Überprüfung der Standardangebote im Zusammenhang mit der Zugangsgewährung zur Teilnehmeranschlussleitung’, öffentlicher Fassung, BK3e-15/011, p. 503.

**Scenario II.** Assumed that the incumbent ‘A’ decides to expand their fibre-based access network and deploy FTTB by installing a second XG.fast in the building’s basement. This does not change the fact that the in-building infrastructure remains based on old copper wires and vectoring procedures still require all copper pairs to be controlled by a single network provider. Particularly XG.fast, as it uses the TDD method (‘time division multiplex’) for direction separation, so that not only interferences from ‘far end crosstalk’ (FEXT) but also from ‘near end crosstalk’ (NEXT) are expected.<sup>38</sup> Thus, having several network providers using XG.fast at one location would only amplify these effects.<sup>39</sup> For this reason, only one XG.fast DPU may be operated at one location.<sup>40</sup>

These scenarios would not be a source of concern, if the in-building cabling practices in Germany would have met the standards of shielded copper cables that have been existing for at least the past 30 years, i.e. category 5 cable according to the ISO/IEC 11801, also known as cat5. Then, ‘cross-talk’ would be much less of a problem today.<sup>41</sup>

#### 4.2.2 Coaxial cable

In light of the issues of sharing copper wires, some G.fast providers have proposed that it should be possible for them to use the existing coaxial in-building infrastructure instead.

Coaxial cables consist of single solid copper wires (inner conductor) and a braided shield around it (outer conductor).<sup>42</sup> Due to its design-inherent shielding, there is no magnetic field outside the cable. In contrast to unshielded twisted copper pairs, they are not subject to electromagnetic interferences (or ‘cross-talk’), making coaxial cables well suited for the transmission of high-frequency signals.<sup>43</sup>

Due to their shield design, coaxial cables were initially used for the transmission of high-frequency television signals, allowing the deployment of cable TV networks roughly 40 years ago. Yet, in contrast to telephone copper cables, coaxial cables consist only of a single copper wire, which must be then shared by multiple households. As television signals transmits in one direction and in a broadcast fashion (one-to-all) uniform content to all the households, the use

---

<sup>38</sup> Near-end cross talk (NEXT) occurs when a signal from a transmitting cable interferes with a receiving cable at the same end. While in far-end cross talk (FEXT) the signal interferes with a receiving cable at the opposite end (Hewlett-Packard, 1995. ‘Cross talk in unshielded twisted-pair cables’. Hewlett-Packard Journal, August 1995).

<sup>39</sup> VDSL2 is only affected by ‘far end crosstalk’ (FEXT), as it avoids ‘near-end crosstalk’ (NEXT) by using frequency-division duplexing, upstream and downstream (Colmegna, A., Galli, S. and Goldberg, M., 2012. ‘Methods for supporting vectoring when multiple services providers share the cabinet area’, p.1).

<sup>40</sup> Elektronik-Kompendium.de (2022). ‘G.fast / ITU-T G.9700 und G.9701’. <https://www.elektronik-kompendium.de/sites/kom/2005121.htm>. Last accessed: 19.11.2022.

<sup>41</sup> Plückerbaum and Ockenfels (2020). ‘Kosten und andere Hemmnisse der Migration von Kupfer- auf Glasfasernetze’. WIK Discussion Paper Nr. 457, p.11.

<sup>42</sup> Elektronik-Kompendium.de (2022). ‘Koaxialkabel’. <https://www.elektronik-kompendium.de/sites/kom/0308051.htm>. Last accessed: 06.10.2022.

<sup>43</sup> Kulenkampff, G., Ockenfels, M., Plückerbaum, T. Zoz, K., Zuloaga, G. (2022). ‘Technische Aspekte der räumlichen Erstreckung von Anschlussnetzen’, p. 16.

of coaxial cables as a 'shared medium' was sufficient for that purpose.<sup>44</sup> In this context, cable TV networks were designed and deployed separately from the existing telecommunication networks. Since coaxial cable was conceived as a 'shared medium', it was deployed mostly in 1980s in a 'tree' structure.

With the development of DOCSIS (Data over Cable Service Interface Specification), the provision of internet services over coaxial cables in addition to the transmission of cable television became possible. DOCSIS defines the frequency ranges in a single coaxial cable that can be used for individual broadband communication in both directions.<sup>45</sup> By applying 'frequency division duplexing' (FDD) DOCSIS operates down- und upload traffic separately in dedicated parts of the frequency spectrum.

Latest generations DOCSIS 3.1 and DOCSIS 4.0 are capable of reaching gigabit speeds. With frequency ranges up to 1,8 GHz, DOCSIS 3.1 has a total transmission capacity of 1 Gbps for upstream and 10 Gbps for downstream communication. By using the same frequency spectrum at the same time for up- and downstream traffic ('full duplex' instead of 'frequency division duplexing' FDD), its successor, DOCSIS 4.0, reaches symmetrical total transmission capacities of 10 Gbps for both down- und upstream.<sup>46</sup>

These newer DOCSIS generations have very high total transmission capacities available. DOCSIS 3.1 supports a commonly usable bandwidth of 10 Gbps down- and 1 Gbps upstream, while DOCSIS 4.0 offers 10 Gbps in both directions. The actual data rate that is delivered to end user will heavily depend on the number of active connections that share the same coaxial cable, thus the fibre node size of customers connected. Similarly to 'fibre-to-the-x' in the access network, the expansion of fibre in cable TV networks allows to shift the fibre-node from the CMTS closer to the customer, reducing the number of end users at a fibre-node sharing the same coaxial cable.

DOCSIS 3.1 and DOCSIS 4.0 typically have different sizes of fibre nodes. Since DOCSIS 3.1 is designed to support larger fibre nodes, the total bandwidth capacity of the coaxial cable has to be then shared among more connections. Yet, the individual data rate available to the end user does not only depend on the number of connections but also on the number of active users connected at the same time. While this is not a constant variable, it should be assumed that in peak hours 20% of connections are simultaneously active.<sup>47</sup> The following figure illustrates the achievable transmission speeds to end users with DOCSIS 3.1 and 4.0 under different scenarios.

---

<sup>44</sup> Plückebaum, T., Eltges, F., Ockenfels M. (2019). 'Potenziell anzunehmende Vorleistungsprodukte in Kabelnetzen auf der Basis von DOCSIS;', Studie für die Bundesnetzagentur, p. 4.

<sup>45</sup> The individual communication on a 'shared medium' is administered by the 'cable modem termination system' (CMTS) located at a central location.

<sup>46</sup> Hamzeh, B. (2016). 'Full Duplex DOCSIS Technology: Raising the Ante with Symmetric Gigabit Service'. Cablelabs. <https://www.cablelabs.com/blog/full-duplex-docsis-3-1-technology-raising-the-ante-with-symmetric-gigabit-service>. Last accessed: 23.11.2022.

<sup>47</sup> Plückebaum et. al, (2019). Vorleistungsprodukte in Kabel-TV-Netzen, p.10 (see European Commission, 2021. 'Annexes to the Guidelines on State aid for broadband networks'. Draft (15), p.2).

Figure 4-5: DOCSIS 3.1 and DOCSIS 4.0 – Individual transmission speeds for end users for different fibre-node sizes (at busy hour = 20% simultaneity)<sup>48</sup>

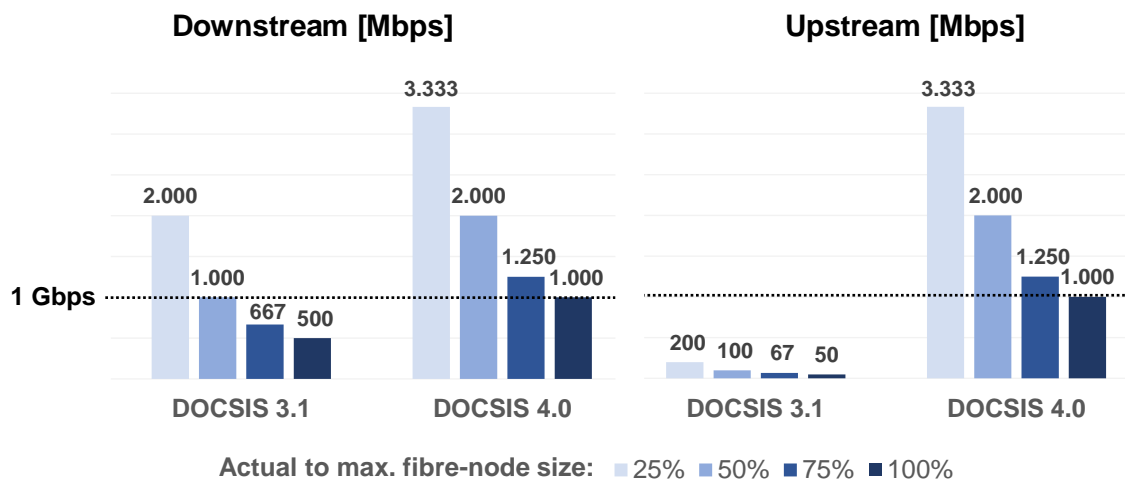

Source: WIK. The maximal capacity of a fibre-node is estimated at 100 connections for DOCSIS 3.1 and at 50 connections for DOCSIS 4.0.

Figure 4-6 shows, how sensitive broadband speeds over coaxial cable are to changes in the size of the fibre-node under a 20% simultaneity assumption. For a maximal fibre node capacity (100 connections for DOCSIS 3.1 and 50 connections for DOCSIS 4.0) only DOCSIS 4.0 is capable of delivering gigabit speeds to the end user. It is clear that in none of the presented scenarios (from 100% to only 25% fibre node capacity), DOCSIS 3.1 is capable of achieving gigabit speeds in upstream communication.<sup>49</sup> Yet, in downstream communication, DOCSIS 3.1 may deliver individual gigabit speeds to the end user in certain constellations (i.e. fibre node has no more than 50 connections, which is 50% of the assumed maximal capacity size). In contrast to DOCSIS 3.1, its successor DOCSIS 4.0 can achieve gigabit speeds for both down- and upstream in all assumed scenarios.

While DOCSIS 4.0 is not yet implemented in Germany, Vodafone, the major cable internet provider in Germany, has recently disclosed being testing and validating this technology, without providing an official release date.<sup>50</sup> Some experts estimate that it will be commercially available as soon as in 2024<sup>51</sup> or even as late as 2030<sup>52</sup>. The upgrade to DOCSIS 4.0 will mostly require technical modifications outside the building, at cable-fibre access network, also

<sup>48</sup> Calculation of the individual data rate is performed as follows: total data rate capacity / (fibre node capacity in x-scenario (from 25% to 100% of fibre node maximal capacity) x 20% simultaneity).

<sup>49</sup> It may only be theoretically achieved, if the fibre-node was deployed to connect only one single connection.

<sup>50</sup> Vodafone (2022). 'Vodafone Group Plc. H1 FY23 Results'. Presentation from 15. November 2022. <https://investors.vodafone.com/sites/vodafone-ir/files/2022-11/vodafone-h1-fy23-results-presentation.pdf>. Last accessed: 23.11.2022.

<sup>51</sup> Goldmedia GmbH Strategy Consulting (2020). 'Evolution der HFC-Netze bis 2030: Zukunftsfähigkeit der Kabelnetze im Wettbewerb der Gigabit-Infrastrukturen. Kurzstudie. Vodafone Institut für Gesellschaft und Kommunikation.

<sup>52</sup> <https://www.roedl.de/themen/kompass-telekommunikation/2022/10/docsis-vier-null-alternative-zu-glasfaser>. Last accessed: 22.11.2022.

known as network level 3 (NE3), and at the customer side by exchanging the cable modems. Alternatively, Vodafone might change to full FTTH, based on XGS.PON, or a combination thereof, as rumours in the market whisper.

### Sharing in-building infrastructure based on coaxial cables

Similarly to the traditional telephone copper wires, the main purpose of using and sharing in-building coaxial cables is to take advantage of the widespread availability of an already existing in-building infrastructure, especially among multi-dwelling units built between the 1960 and 1990, which were the majority of cases wired in with coaxial cabling.<sup>53</sup>

In contrast to the traditional telephone copper wires, coaxial cables are shared by several end users at the same time. This usually occurs at the cable access network (NE3), where coaxial cables are deployed in a branched or star-shaped structure. Here, the coaxial cable can be shared by up to 50 to 100 households. Due to its physical properties as a 'shared medium', it cannot be physically unbundled at this network level.<sup>54</sup> Yet, at the building network (NE4), whether the physical unbundling is technically feasible depends on the type of cabling structure of the building:

- 'tree' structure
- 'star' structure

Figure 4-6: Typical in-building cabling structures in multi-dwelling units in Germany

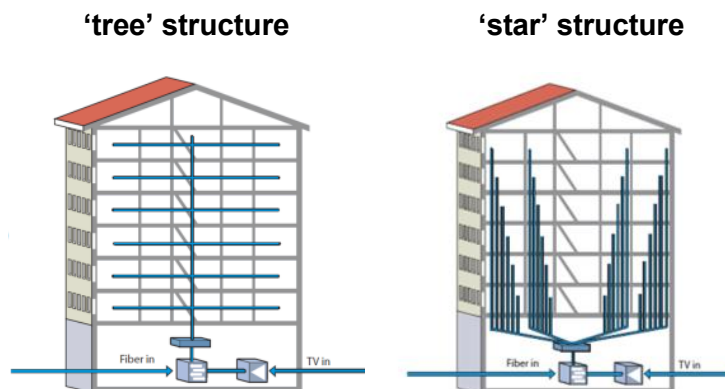

Source: Multimedia over Coax Alliance MOCA (2021). 'Copper Broadband Technology Developments. MDU Connectivity Enhancements. Conference 2021 broadband forum. [https://mocaalliance.org/access/MDU-Connectivity-Enhancements\\_MoCA\\_UFBB-Virtual-Conference-2021.pdf](https://mocaalliance.org/access/MDU-Connectivity-Enhancements_MoCA_UFBB-Virtual-Conference-2021.pdf). Last accessed: 23.11.2022.

<sup>53</sup> Multimedia over Coax Alliance MOCA (2021). 'Copper Broadband Technology Developments. MDU Connectivity Enhancements. Conference 2021 broadband forum. [https://mocaalliance.org/access/MDU-Connectivity-Enhancements\\_MoCA\\_UFBB-Virtual-Conference-2021.pdf](https://mocaalliance.org/access/MDU-Connectivity-Enhancements_MoCA_UFBB-Virtual-Conference-2021.pdf). Last accessed: 23.11.2022.

<sup>54</sup> Plückebaum, T., Eltges, F., Ockenfels M. (2019). 'Potenziell anzunehmende Vorleistungsprodukte in Kabelnetzen auf der Basis von DOCSIS;'. Studie für die Bundesnetzagentur, p. 21.

In a 'tree' structure, single or multi-riser coaxial cables coming from the building-entry-point (BEP) in the building's basement are progressively branched out to each end user's apartment as they go up, often – i.e. in large multi-dwelling units - requiring intermediate amplifiers. In a 'star' structure, each apartment is directly connected to building-entry-point (BEP) by an individual coaxial cable. As the latter is not shared with any other end users in the building, only in-building coaxial cables that are deployed in a 'star' shaped structure can be physically unbundled at the building's basement.<sup>55</sup>

According to recent information from the main cable internet providers in Germany (Vodafone, Unity Media and Columbus), for the building network (NE4) in Germany, coaxial cables are today predominantly deployed in a 'star' shaped cabling structure.<sup>56.57</sup> Yet, it is worth noticing that while this may be a practise well established today, most of the coaxial cables have been deployed before they were used for the transmission of broadband data (that is prior to the introduction of DOCSIS in late 1990s). Back then, coaxial cables were deployed as a shared medium with the only purpose of broadcasting one-directional TV signals. This means that for the majority of existing buildings until then, coaxial cables are most likely deployed in a 'tree' structure, as this structure not only fulfils the purpose, for which coaxial cables were originally designed, but also is more resource-saving compared to the alternative 'star' structure.

### **Hybrid solutions – G.fast (FTTB) and coaxial cables**

If a building is already provided with DOCSIS services from a cable operator, G.fast cannot coexist on the same coaxial cable. G.fast requires that the coax infrastructure from the DPU to each apartment runs through an individual coaxial cable ('star' structure), which may not be the case for most buildings in Germany.<sup>58</sup>

### **Multimedia over Coax Alliance (MoCA) Access**

Alternatively, and regardless of the existing coax in-building cabling structure (whether it is 'tree' or 'star' shaped), the reach of fibre broadband in the building (FTTB) can be extended to individual apartments using 'MoCA'. The Multimedia over Coax Alliance 'MoCA' 2.5 is one of

---

<sup>55</sup> Additionally, in the building network (NE4), star-shaped structures are less susceptible to interference, since they are no longer a 'shared' medium within the building.

<sup>56</sup> Frontzeck-Hornke (2014). 'So sieht der derzeitige Sternnetz- und Baumnetz-Ausbau bei den Kabelnetzbetreibern aus'. <https://www.teltarif.de/sternetz-baumnetz-kabel-vorteile-nachteile-vergleich/news/57368.html?page=2>. Last accessed: 23.11.2022.

<sup>57</sup> According to German Gigabit Office coaxial inhouse networks (network level 4) are installed in a star structure (Gigabitbüro des Bunde, 2022. 'Mehr über Gigabit Technologien erfahren'. <https://gigabitbuero.de/thema/gigabittechnologien/>. Last accessed: 29.11.2022).

<sup>58</sup> Incoax Networks AB (2019). 'Umwandlung von Kabelnetzen in Multi-Gigabit-Glasfaser-Erweiterungen Chance für HFC-, Telekommunikationsund Glasfaserbetreiber'.

the latest transmission protocols for ethernet over coax.<sup>59</sup> This access technology is commonly used in residential units in North America.<sup>60</sup>

MoCA is intended to be used on existing coaxial cables under the principle of frequency division. That means that the total bandwidth available in the coaxial cable is to be divided into non-overlapping frequency bands, on which each services or operator delivers their own separate signal. Thus, services such as DOCSIS or cable TV may coexist with MoCA on same existing coaxial cables, so long the cable has enough total bandwidth capacity and the frequency bands are sufficiently separate from each other.

In general, MoCA 2.5 can use the spectrum between 400 MHz and 900 MHz, or if required it can be configured to a mode to occupy a spectrum between 1.175 MHz to 1.675 MHz or even above, depending on the supplier, when other existing services over the same coaxial cables, i.e. DOCSIS or cable TV, are already in place and wished to be maintained (see Figure 4-7).<sup>61</sup>

Figure 4-7: MoCA 2.5 extended band D frequency plan

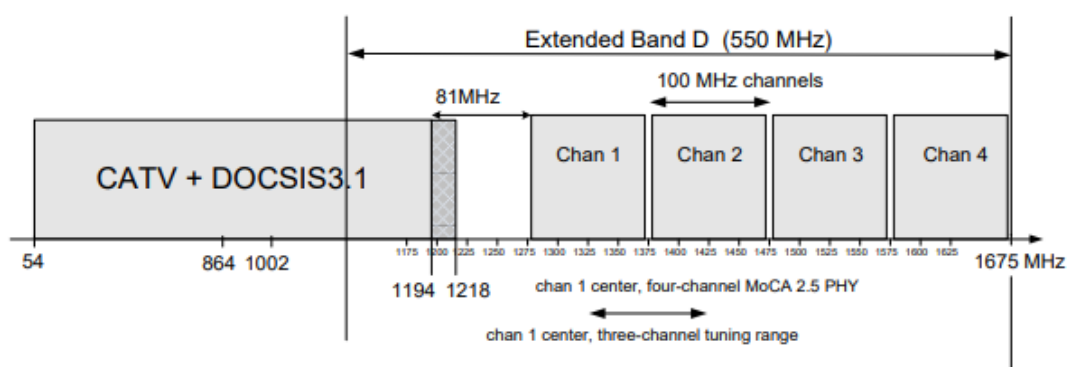

Source: Multimedia over Coax Alliance - MoCA (2015/16). 'MoCA 2.0/2.5 Specification for Device RF Characteristics'. 20160808, p. 13.

MoCA 2.5 supports different bands of operation (i.e. band D, E). Figure 4-7 illustrates the specifications of MoCA 2.5 frequency plan in extended band D in the presence of cable TV and DOCSIS 3.1 (extended up to 1.194 - 1.218 MHz). Here, DOCSIS signals and MoCA signals may coexist, when overlapping is avoided and adequate placement and performance of filters guarantee sufficient isolation.<sup>62</sup>

In order to the frequency division to work, MoCA requires its own active network in the building. In a FTTB scenario, by just connecting the MoCA access modem at the end user's apartment,

<sup>59</sup> 'MoCA' 1.0 was first approved in 2006. The latest version, 'MoCA' 2.5 was released in 2016. MoCA technology works with GPON/EPON, DOCSIS, Ethernet and any network access technology (Multimedia over Coax Alliance, 2021. FAQs. [MoCA for Installers :: MoCA FAQs \(moca4installers.com\)](https://www.moca4installers.com/)- Last accessed: 14.12.2022).

<sup>60</sup> Kuzlu, M. and Rahmen, S. (2015). , Review of Communication Technologies for Smart Homes/Building Applications'. IEEE Innovative Smart Grid Technologies Conference (ISGT-ASIA). Bangkok, Thailand. November 4-6, 2015, p. 3.

<sup>61</sup> GiaX (2022). 'IRIS™-Lösung'. <https://www.giax.de/de/produkte/iris>. Last accessed: 22.11.2022.

<sup>62</sup> As DOCSIS and Multimedia over Coax Alliance (MoCA) signals share common frequencies above 1 GHz, they may impact each other, leading to significant performance degradation, in some scenarios, one or both networks may entirely fail to perform (Society of Cable Telecommunications Engineers, 2017. 'Operational



installing the MoCA access DPU in the basement and connecting it with the existent in-building coaxial cables (see Figure 4-9), data rates of 2,5 Gbps downstream and 2 Gbps upstream can be reached in a segment with a maximum of 31 participants. The entire system is managed centrally by the Management Software (one Network Controller per building) and coexists with other services on the coax such as cable TV, cable modem, and satellite services.<sup>63</sup>

Figure 4-8: Multimedia over Coax Alliance (MoCA) access

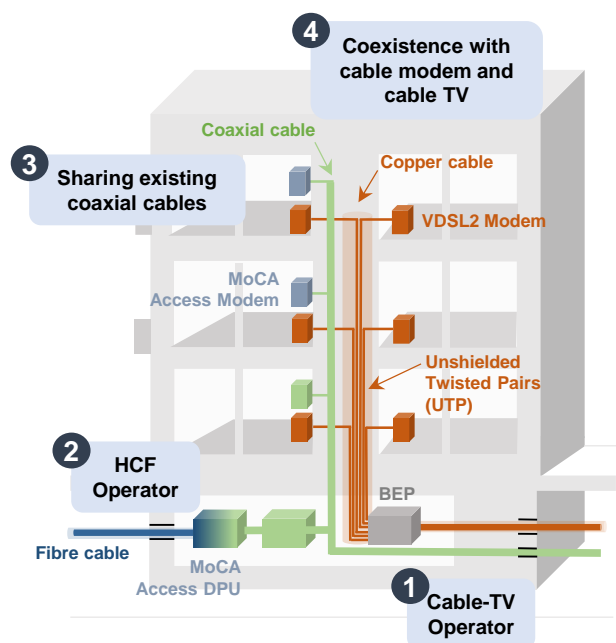

Source: WIK.

Figure 4-8 depicts how existing in-building coaxial cables deployed in a 'tree' structure<sup>64</sup> may be shared among different network operators to serve their customers within the same building. By using MoCA access technology, end users are able to expand their options and change to a new FTTB internet provider, instead of limiting their alternatives to older networks deployed by the incumbent or the cable tv operator. In this context, it is not required the entire building to agree with the change to the FTTB provider, nor they have to give up the use of existing services over coax such as cable or satellite TV.

**Requirements.** In order to avoid overlapping of frequency bands, the total bandwidth capacity of the existing coaxial cables need to be upgraded. MoCA requires an extension of the frequency spectrum of at least up to 1,8 GHz. While frequency ranges up to 2,5 GHz can be

Practise for Coexistence of DOCSIS 3.1 Signals and MoCA Signals in the Home Environment. Engineering committee. SCTE Standard, SCTE 235 2017, p.6).

<sup>63</sup> Ljungdahl, A. and Zhao, J. (2012). , State-of-the-Art and Emerging Multimedia-over-Coax (MoCa) Solutions and Deployments'. European Conference and Exhibition on Optical Communication.

<sup>64</sup> Even in a 'loop-through' structure, MoCA is robust enough in allowing devices to communicate with one another (Society of Cable Telecommunications Engineers, 2017. 'Operational Practise for Coexistence of DOCSIS 3.1 Signals and MoCA Signals in the Home Environment. Engineering committee. SCTE Standard, SCTE 235 2017, p.18).

developed in coax networks, this requires upgrading networks components such as TAPs and the amplifiers in order to support higher bandwidths. In contrast to xDSL and DOCSIS networks, which are operated by the normal Telcos, MoCA is an in-building network with a separate network operation responsibility, which requires an in-building network operator.

#### 4.2.3 Opportunities and limitations

##### Technical constraints on existing in-building infrastructures

###### Opportunities

- **Ripping off gains from existing infrastructure.** Laying new cables is not necessary, nor remodelling measures. This translates into cost savings as the existing infrastructure is immediately available.
- **Physical unbundling in HFC networks** that work in either 'star'-shaped in-building cabling structures (i.e. G.fast-coax solutions), where individual coaxial cables are directly routed to each home, or by using MoCA access technology in HFC or FTTB environments for building units with up to 31 households regardless of the building structure.

###### Limitations

- **Physical access and infrastructure sharing on UTP:** Performance-enhancing correction methods such as 'vectoring' are not effective when third-party providers use in-building infrastructure based on unshielded twisted pairs in parallel. Thus, the shared use of existing old telephone copper cables generates significant loss in signal quality.
- **Tree structure.** Physical unbundling in HFC networks often requires a 'star' structure. Nevertheless, for most of the existing buildings, coaxial cables has been mainly laid out in a 'tree' structure.
- **Limited practicability.** MoCA cannot be implemented on the basis of the current DOCSIS 3.1 (with predominantly frequencies up to 1.2 GHz). An upgrade to DOCSIS 4.0 in Germany is currently not foreseeable.
- **These technical solutions (i.e. MoCA) are not future-proof,** as there is a trade-off between the bandwidth available for MoCA and the number of competitors that are allowed to share a coaxial cable. Data rates are to limited to max. 2 to 2.5 Gbps, which is further restricted by the scope of the shared use (i.e. with DOCSIS) and the number of end users (maximal 31 per building). In this regard, MoCA is ultimately a shared medium that limits the frequency range and bandwidth for each operator. It requires an in-building network operator. MoCA can provide an interim solution before and during a FTTH migration.

## 4.3 Future-proof solutions for gigabit capable in-building infrastructures

### 4.3.1 Fibre optic cable

An optical fibre strand consists of a core, cladding and outer coating and is constructed from high purity silica. Fibre transmits information using beams of light, which are generated by lasers and transmitted through the core to a receiving sensor.<sup>65</sup> In contrast to copper cables, which transmit electrical signals, optic fibre cables transmit optical signals and are entirely insensitive to electromagnetic interference ('cross-talk') and any type of failures faced by copper-based networks.<sup>66</sup>

#### Typical in-building topologies

A distinction can be made here between two fibre-based network topologies, fibre optic Point-to-Point (PtP) and fibre optic Point-to-Multipoint (PtMP). These network topologies can be further distinguished between 'active optical networks' (AON) and 'passive optical networks' (PON), depending on the type of equipment they implement for the distribution of fibre to the end user.

- FTTH PtP (Point-to-Point) connects the Metropolitan-Point-of-Presence (MPoP) to each apartment or home using an individual fibre strand. Each individual fibre entering the building is routed through a single-fibre management system at the 'optical termination point' or 'building-entry-point' (BEP) to the respective apartment.<sup>67</sup> This means that from the MPoP, each apartment is provided with an individual fibre optic cable without the intermediation of active equipment for the fibre distribution (see Figure 4-9).<sup>68</sup>
- FTTH PtMP (Point-to-Multipoint) have two variants: as 'passive optical network' (PON) or as 'active optical network' (AON). In the PON variant, each apartment is connected by an individual fibre link, which form a group of fibres that are then connected to a passive optical splitter somewhere at a concentration point in the building (i.e. at floor level, in the basement). The aggregation of all these fibres to one fibre link is also called 'feeder fibre'. This 'feeder fibre' is shared between all users of the apartment group. Within the building, splitters are often used in a cascaded form, where the splitting factor (typically 1:32) must hold throughout the cascade. In the

---

<sup>65</sup> FTTH Council Europe (2018). FTTH Handbook Edition 8. D&O Committee. Revision Date: 13/02/2018, p. 127-128.

<sup>66</sup> As they are also not sensitive to water, there is no probability of failure caused by humidity and water.

<sup>67</sup> Since each apartment requires at least one optic fibre, the building distributor requires more space to accommodate the individual fibre management and the corresponding number of splices (BMVI, 2021. 'Bausteine für Netzinfrastrukturen von Gebäuden', p.17).

<sup>68</sup> In PtP architectures, active elements are only located in the MPoP and at the end customer.

AON variant, active equipment (switches) are used instead of an optical splitter (see Figure 4-9).

Figure 4-9: Reference models for FTTH PtP and PtMP within the building

### Point-to-Point (PtP)

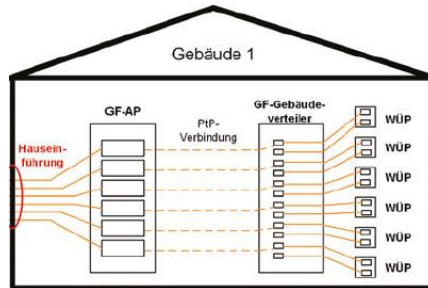

### Point-to-Multipoint (PtMP)

#### Passive optical network (PON)

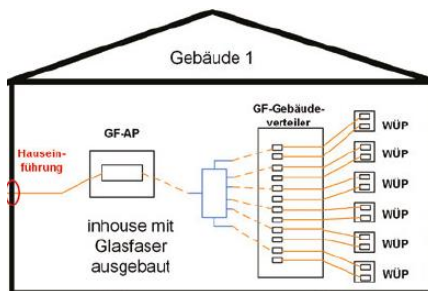

#### Active optical network (AON)

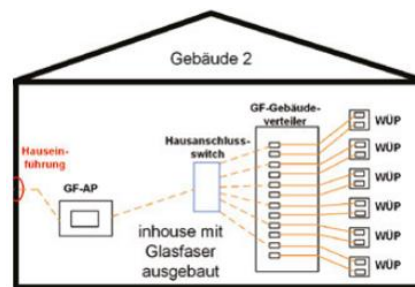

Source: Extract from BMVI (2021). ‚Bausteine für Netzinfrastrukturen von Gebäuden‘, pp.17-19 (original source: ANGA Der Breitbandverband e. V.).

## Transmission techniques

Transmission technologies capable of working with optical signals and therefore suitable for fibre-based network architectures are Ethernet over Fibre and Gigabit Passive Optical Network (GPON, in its general architecture family called x.PON):

- **Ethernet** can operate on different transmission mediums, yet Ethernet over fibre can transport massive amounts of data. For the access network, the standard 'Ethernet for the first mile' (IEEE 802.3ah) is usually used. Here, up to 100 Mbps with 'Fast Ethernet' and up to 1.000 Mbps with 'Gigabit Ethernet' over single-mode fibre can be delivered to the end user.<sup>69</sup> Ethernet ports at this network level today already usually support between 1 to 10 Gbps. In Switzerland, Init7 provides 25 Gbps per fibre link.<sup>70</sup> The

<sup>69</sup> Fast Ethernet is referred to as '100Base-BX10' and Gigabit Ethernet as '1000Base-BX10'. Both specifications are defined for a nominal maximum range of 10 km.

<sup>70</sup> Init7 (2022). 'Warum Internet von Init7'. <https://www.init7.net/de/internet/warum-init7/>. Last accessed: 12.12.2022.

majority of PtP FTTH deployments uses Ethernet, but it can be mixed with other transmission schemes such as SDH/ SONET or WDM.<sup>71</sup>

- **x.PON** is gigabit capable optical transmission technique used for data the transmission on passive optical network (PON) architectures based on splitters. With x.PON, Down- and upstream communication are handled on different wavelengths.<sup>72</sup> Several new generations have been developed and standardized (i.e. XG.PON with higher transmission data rates and XGS.PON with symmetrical transmission data rates).

## Transmission speeds

The transmission capability of fibre optics has been improved continuously over time.<sup>73</sup> Today, massive amount of data (theoretically gigabit to terabit per second) over very long distances (over a hundred kilometres without a repeater) can be transmitted over fibre.<sup>74</sup> Yet, in network architectures, where fibre is deployed as a 'shared medium' (i.e. by x.PON transmission series), its bandwidth capacity has to be shared among end users. Thus, the individual data rate of each end user will be determined by the number of end users sharing the same fibre. In x.PON series, the number of end users depends on the actual splitting ratio used. The different transmission speeds delivered to the individual end user under different splitting ratios are depicted in Figure 4-10.

---

<sup>71</sup> Wavelength Division Multiplex.

<sup>72</sup> Elektronik-Kompendium.de (2022). ‚GPON - Gigabit Passive Optical Network (ITU G.984)‘. <https://www.elektronik-kompendium.de/sites/kom/1403181.htm>. Last accessed: 30.11.2022.

<sup>73</sup> Deutsche Telekom (2022). Glasfaserkabel als Lichtwellenleiter für schnelles Internet. <https://www.telekom.com/de/konzern/details/glasfaserkabel-als-lichtwellenleiter-fuer-schnelles-internet-612108>. Last accessed: 18.07.2022.

<sup>74</sup> Deutsche Telekom (2022). Glasfaserkabel als Lichtwellenleiter für schnelles Internet. <https://www.telekom.com/de/konzern/details/glasfaserkabel-als-lichtwellenleiter-fuer-schnelles-internet-612108>. Last accessed: 18.07.2022.

Figure 4-10: Ethernet over Fibre and x.PON series – Individual transmission speeds for end users in different splitting ratios (at busy hour = 20% simultaneity)<sup>75</sup>

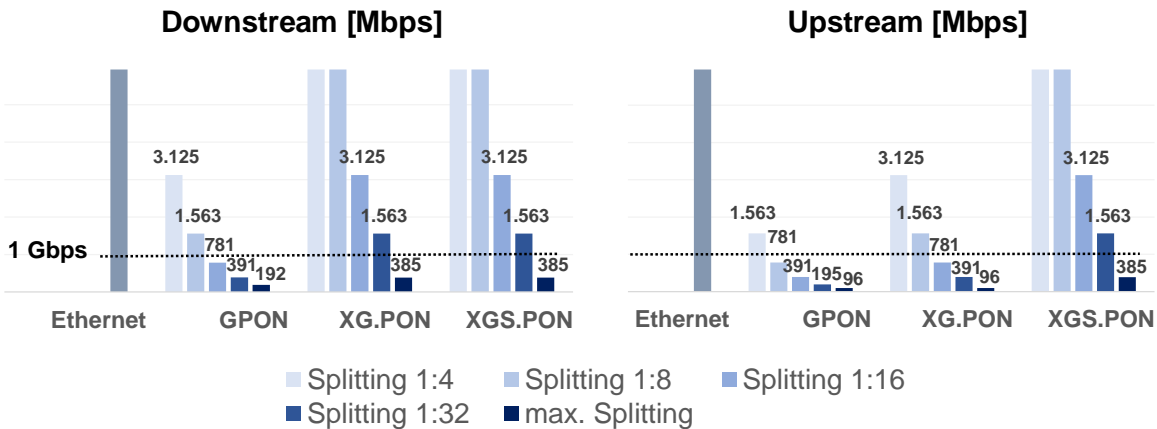

Source: WIK. The maximal splitting ratio is set at 1:1 for Ethernet PtP, 1:64 for GPON and at 1:128 for XG.PON and XGS.PON.

Figure 4-10 shows the maximal down- und upstream speeds that can be delivered to an individual end-user by using Ethernet (in a PtP architecture) and x.PON series (in a PtMP architecture) considering for the latter multiple splitting scenarios. Whereas Ethernet in a PtP-architecture can reliably deliver over 1 Gbps to the end user, in a PON architecture, the state of the art generation, XGS.PON, is capable to deliver gigabit speeds to the end user under splitting ratios up to 1:32, for both down- und upstream communication. GPON can the same only under low splitting ratios (up to 1:4).

This exemplifies how sensitive the delivery of gigabit speeds is, when fibre is deployed in a Point-to-Multipoint (PtMP) architecture. In principle, the data rate provided to the end user in PtMP architectures is subject to the uncertainty about the number of end users sharing the same fibre at the same time. The higher the number of end users sharing the same capacity, the lower the data rate they will get individually. While the simultaneity among users may not be a fixed factor (here it is assumed at 20% at the busiest hour), the number of potential active end users certainly increases, the higher the splitting ratio. Thus, due to the ‘shared’ nature of PtMP architectures, gigabit speeds to the end user cannot always be secured. PtP architecture is significantly more reliable in this regard.

**Technical requirements**

Different areas of application require different types of optical fibre. Not any type of fibre is adequate for the deployment within buildings. Fibres from the in-building cabling (indoor cable) have not the same requirements as the fibres from the drop cabling (outdoor cable).<sup>76</sup> In-building cable deployment is mostly characterized by short distance installations, which

<sup>75</sup> Calculation rule see footnote 48.  
<sup>76</sup> FTTH Council Europe (2018). FTTH Handbook Edition 8. D&O Committee. Revision Date: 13/02/2018, pp. 67-68.

restricts the bending radius of cables. As the performance of optical fibre is sensitive to macro bending, the specifications of the indoor cables must fulfil the following requirements:

- Bend-insensitive single-mode fibres (according to ITU-T G.657.A2).<sup>77</sup>
- Max. insertion loss 1.5 dB; min. return loss 30 dB (from the building distributor to the telecommunication outlet).<sup>78</sup>
- Optical loose tube fibre cables (according to the IEC 60794 series) or micro-ducts for installation by blowing technique (according to the IEC 60794-5 series) at the 'building-entry-point' (BEP).<sup>79</sup>

### Sharing in-building fibre cables

The expansion of cable TV in existing buildings led to the existence of two parallel running copper-based networks (coax and copper pairs), which may have added competition from the cable network provider. In contrast to copper-based inhouse cabling, due to the physical properties of optical fibre, it is technically possible to share the use of in-building fibre infrastructure by two or more FTTH competitors and achieve a competitive physical access to the building by unbundling individual fibres. Thus, with fibre, duplicating the in-building network is neither efficient nor necessary.<sup>80</sup>

**Fibre unbundling.** Since fibres are not sensitive to electromagnetic interferences from neighbouring cables ('cross-talk'), laying fibres next to each other is not an issue. More precisely, unbundling individual optic fibres from a fibre strand that share a common cable is not subject to the technical limitations faced by unshielded twisted copper wires. Also, individual fibres in a 'star' or 'tree' cabling structure do not pose the type of restrictions on bundling seen with coaxial cables.<sup>81</sup> In this context, when a fibre cable per home is deployed containing one or multiple optic fibres, each operator may share the cable and use one or more

---

<sup>77</sup> Digital Gipfel (2020). 'Leitfaden zur Errichtung von Glasfasergebäudenetzen'. Handreichung der Fokusgruppe „Digitale Netze“ Plattform „Digitale Netze und Mobilität“, p. 15.

<sup>78</sup> Digital Gipfel (2020). 'Leitfaden zur Errichtung von Glasfasergebäudenetzen'. Handreichung der Fokusgruppe „Digitale Netze“ Plattform „Digitale Netze und Mobilität“, p. 28.

<sup>79</sup> FTTH Council Europe (2018). FTTH Handbook Edition 8. D&O Committee. Revision Date: 13/02/2018, p. 69.

<sup>80</sup> Von Hammerstein, A. (2010). ‚Zugang zur Inhouse-Verkabelung für NGA aus Sicht der Kabelnetz-betreiber‘. Kabel Deutschland. Präsentation für das NGA-Forum der Bundesnetzagentur. <https://docplayer.org/57214899-Zugang-zur-inhouse-verkabelung-fuer-nga-aus-sicht-der-kabelnetzbetreiber.html>. Last accessed: 12.12.2022.

<sup>81</sup> In in-building fibre networks, the decision regarding the type of cabling structure may be relevant in other aspects. For instance, optic fibres deployed in a 'tree' structure that have different sized cables branching out through the floors may require more splices (and therefore higher signal attenuation due to 'splice losses') compared to a 'star' structure.

of those fibres to supply their end customers with broadband services. There are two types of fibre unbundling:<sup>82</sup>

- **Multi-fibre unbundling:** if the apartment or home have fibre cables dimensioned to support multiple fibres, each competing operator can easily access the building with their dedicated fibres and directly connect to the apartment.<sup>83</sup>
- **Mono-fibre unbundling:** if the apartment or home only dispose of a single fibre, then its access is open to all competing operators. Yet, the actual connectivity of the apartment or home is granted to only one network provider at the same time. This is managed at a 'Point of Interface' (PoI) by a fibre cross-connect, which is usually a passive manual connected fibre distribution panel. Thus, a change of network provider can be achieved by switching the connection from the old to the new operator.<sup>84</sup>

### Limitations of sharing in Point-to-Multipoint (PtMP) in-building architectures

Passive optical splitters are central network elements in Point-to-Multipoint (PtMP) PON architectures. They do not require power, climate control or maintenance, with just mirrors, prisms and glass, they split the light into two or more optical signals, splitting the fibre into two or more fibre strands. This feature usually promises network operators and investors a more flexible and efficient use of fibre.<sup>85</sup> Whereas splitters are traditionally used in the access network (NE3), when used within a building, they need to be placed at the building's concentration point. In this regard, the network operator may establish one or multiple concentrations points. This decision, on where and how splitters are deployed within the building, has direct implications on the accessibility of the building and on the unbundling possibilities for in-building fibre cables. If the inbuilding fibre cannot be unbundled due to splitters, none of the fibres affected can be unbundled at any network level above (i.e. Fibre distributor, MPoP). Fibre unbundling is only feasible at the splitter closest to the end customer.

In this context, the network operator have the following options for placing the splitter(s):

- a single splitter for the entire building.
- 'cascaded' splitters (multilevel structure with a splitter i.e. in each floor).

A **single splitter** is usually placed in the building's basement. In this topology, incoming individual fibres from every apartment are connected to the passive optical splitter in the

---

<sup>82</sup> With optic fibre cables, wavelength ( $\lambda$ ) unbundling is theoretically possible yet in a context of accessing in-building infrastructure highly unpractical compared to fibre unbundling. Wavelength unbundling is rather used in higher network levels, where the same fibre may be used simultaneously by multiple providers by using separate transmission wavelengths, i.e. wavelength division multiplexing, WDM (FTTH Council Europe, 2018. FTTH Handbook Edition 8. D&O Committee. Revision Date: 13/02/2018, pp. 55-56).

<sup>83</sup> Switzerland typically has 4 fibres per home, the dense populated areas in France as well are provided with several fibres per home. The probability of two fibres being used in parallel by the same end customers is low.

<sup>84</sup> FTTH Council Europe, 2018. FTTH Handbook Edition 8. D&O Committee. Revision Date: 13/02/2018, p. 56.

<sup>85</sup> Optigo Networks (2019). 'What are passive optical splitters?'. <https://www.optigo.net/what-are-passive-optical-splitters/>. Last accessed: 13.12.2022.



building's basement to form one fibre link shared between all users of the apartment group. If one or more subscribers change network provider, the new provider must place his own splitter in the building's basement and connect the fibres of his customers to his own splitter.

**Cascaded splitting** may be an appealing option for investors or network providers, as it may reduce some of the costs associated with network deployment, particularly in large multi-dwelling units with potentially high take-up rates. In a cascade topology, splitters are distributed throughout the building instead of being centrally located in the building's basement. In high-rise buildings with over 12 floors and/or over 8 subscribers per floor, the first splitter of the cascade scheme can be placed at the 'building-entry-point' (BEP) in the basement.<sup>86</sup> From this initial splitter, multiple outgoing fibres are routed up through the building's riser to connect the cascaded splitters located at the floor level.

Only at this segment of the cascade scheme, floor splitters serve each apartment with individual fibres. Thus, in PtMP PON architectures with cascade splitters, the unbundled access to the apartment's individual fibre is only possible at the last splitter of the cascade scheme, the one closest to the end user (see Figure 4-11).<sup>87</sup>

Figure 4-11: Challenges of sharing and unbundling in Point-to-Multipoint (PtMP) network architectures with passive optical splitters in a cascade form

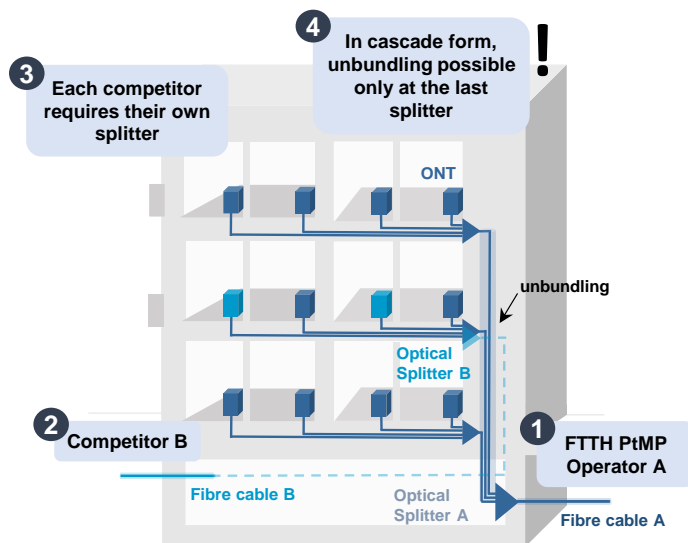

Source: WIK.

Thus, PtMP architectures with cascaded splitters limit the scope to which in-building fibre infrastructure can be shared among network providers. Fibre cannot be unbundled in an easy

<sup>86</sup> Cascade splitters reduce the space requirements of the vertical riser and simplifies the management of cables in the basement. Yet, an increasing amount of hardware has to be installed at the floor level (FTTH Council Europe, 2018. FTTH Handbook Edition 8. D&O Committee. Revision Date: 13/02/2018, pp. 88-89).

<sup>87</sup> Braun, M. R., Wernick, C., Plückebaum, T., Ockenfels, M. (2019). , Parallele Glasfaserausbauten auf Basis von Mitverlegung und Mitnutzung gemäß DigiNetzG als Möglichkeiten zur Schaffung von Infrastrukturwettbewerb'. Diskussionsbeitrag Nr. 456., pp. 17 and 25.

manner and requires competitive fibre access to the splitters. Additionally, as a PtMP fibre topology requires x.PON equipment to control the 'feeder fibre' access, it is not technology neutral.<sup>88,89</sup> Any splitter adds significant attenuation to the fibre access link and thus impacts signal reach or access line length.

The architectural design of in-building cabling should indeed follow the principles of competition, technology neutrality and non-discrimination. Whereas in PtP architectures, where subscribers are connected with individual fibres, such that lines and services can be easily unbundled,<sup>90</sup> PtMP topologies make the access difficult and do not facilitate a competitive multi-operator environment.

### **FTTH topologies and practices of some network providers**

According to public information on how fibre reaches the end user, a technical trainer of the German telecoms operator *Deutsche Telekom* claimed the network operator uses splitters at its distribution frame in the drop-cable segment (NE3) with a maximal capacity of 90 connections. On the way to the customer, the signal branches further out, in a splitting ratio between 1:8 and 1:32 for the delivery of max. 2,5 Gbps to each customer. By doing this, the network operator is capable of switching up to maximally 512 residential units. Whereas it is clear that *Deutsche Telekom* uses cascaded splitters in the access network, it is not clear to which extent this practise also concerns the building network (NE4). Only for new buildings, it is clear that in most of the cases, cascade splitters seem not to be a common practise, as according to this source, *Deutsche Telekom* seem to connect each individual end user directly from the building's basement by using a 'star' shaped empty duct system.<sup>91</sup>

The alternative network operator, *Deutsche Glasfaser*, ensures that from the 'building-entry-point' (BEP) in the building's basement to the telecommunication outlet (TO), every residential unit is supplied with an individual fibre optic line. Thus, their FTTH connections are capable of delivering the booked data rate regardless of whether neighbours are currently active.<sup>92</sup>

The regional network operator *M-net* informs their future customers on their website about the technical requirements for the deployment of a own in-building infrastructure (NE4). In case of two to three family dwellings, a splitter is potentially installed in the building's basement. They

---

<sup>88</sup> The EU calls on networks that are supported by public funds are set up, a "neutral" infrastructure.

<sup>89</sup> This not the case when splitters and the appropriate x.PON equipment are located at the endpoints of the access network, i.e. splitters and OLTs at the MPoP site. Then, the in-building topology (NE4) will follow then a PtP network architecture.

<sup>90</sup> Therefore, PtP networks are technology-independent (BMVI, 2021. 'Bausteine für Netzinfrastrukturen von Gebäuden', p.16).

<sup>91</sup> Kirschkewitz (2022). 'Die Glasfaser-Schule der Telekom: Wie kommt die Glasfaser in die Wohnung (3)'. <https://www.telekom.com/de/blog/netz/artikel/die-glasfaser-schule-der-telekom-wie-kommt-die-glasfaser-in-die-wohnung-3--1007338>. Blog.Telekom vom 31.05.2022. Last accessed: 08.12.2022.

<sup>92</sup> Deutsche Glasfaser (2022). 'Häufige Fragen und Antworten zum Glasfaser-anschluss in Mietwohnungen, wie wird Glasfaser im Haus verteilt?'. <https://www.deutsche-glasfaser.de/mehrfamilienhaeuser/>. Last accessed: 08.12.2022.

require a customer-sided patch field for the termination of the cables in the basement or alternatively the permission to splice the fibres directly towards the 'M-net' splitter.<sup>93</sup>

#### 4.3.2 Passive infrastructure and the role of standardisation

One reason for the late roll out of fibre networks in Germany is the relatively high deploying costs not only in the access network (NE3) but also in existing buildings (NE4), as existing buildings have been traditionally characterized by having cable pathways that are not designed to support the exchange or introduction of new cables.

As future broadband needs and technological developments over the expected lifetime of a building are hard to anticipate, using in-building cabling systems and pathways today that are sufficiently adaptable to exchanging, upgrading or adding new cables without major structural changes in the future is key for an efficient and smooth transformation process.<sup>94</sup>

##### **Types of cable pathways**

In this context, the cable pathways must allow the installation and removal of individual cables without damaging the cables already in place.<sup>95</sup> There are different types of cable pathways:

- Cable ducts
- Micro ducts
- Cable trunks
- Cable trays or mesh trays

**Cable ducts.** Ducts are an assembly that provides an enclosure for the accommodation and laying in of insulated conductors and cables.<sup>96</sup> They protect the cable against damage and allow them to be exchangeable when required.<sup>97</sup> There exist different types of ducts. They can be corrugated or smooth plumbed and can be installed on the surface of a wall or ceiling or concealed within the building fabric.

**Micro ducts.** They are also known as 'speed net ducts' and are small-diameter ducts designed to generate smooth pathways for optical cables. They can only be used for optical fibre, as other types of cable are thicker in diameter and due their material and design cannot be blown

---

<sup>93</sup> M-net (2022). 'M-Net Hausverkabelung'. <https://www.m-net.de/hausverkabelung/>. Last accessed: 08.12.2022.

<sup>94</sup> Batura, O., Plückebaum, T. and Wisser, M. (2018). 'Study on Implementing and monitoring of measures under Directive 61/2014 (Cost Reduction Directive) – SMART 2015/0066, pp. 235-236.

<sup>95</sup> BMVI (2021). 'Bausteine für Netzinfrastrukturen von Gebäuden', p.40.

<sup>96</sup> see IEC 61084-1:2017 © IEC 2017.

<sup>97</sup> Digital Gipfel (2020). 'Leitfaden zur Errichtung von Glasfasergebäudenetzen'. Handreichung der Fokusgruppe „Digitale Netze“ Plattform „Digitale Netze und Mobilität“, p. 13.

into the duct.<sup>98</sup> A micro duct usually allows to blow-in optical fibre from the building's basement to the individual apartment for up to 200 meters.<sup>99</sup>

Figure 4-12: Cable ducts and micro ducts

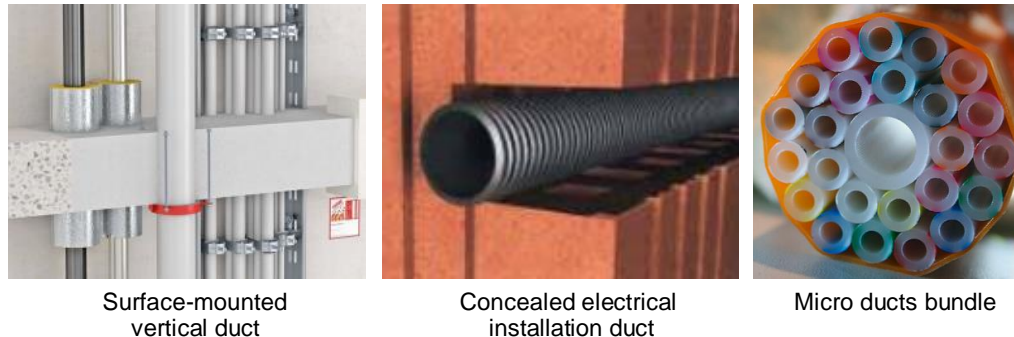

Source: BMVI (2021). ‚Bausteine für Netzinfrastrukturen von Gebäuden‘, p.28; Fränkische (2022). ‚Leerrohrberater für Praktiker. Installationsnormen, -formen, -themen. Brandschutz, Dateninstallation und FAQs‘, p. 19. <https://docplayer.org/109311475-Installation-qualitaet-normen-leerrohrberater-fuer-praktiker-installationsnormen-formen-themen-brandschutz-dateninstallation-und-faqs.html>. Last accessed: 19.12.2022; eAcademy (2022). ‚Breitbandausbau mit Glasfaser: Mikrorohre als Kabelwegsystem‘. <https://eacademy.mitegro.de/2022/02/03/breitbandausbau-mit-glasfaser-mikrorohre-als-kabelwegsystem/>. Last accessed: 19.12.2022 (originally from [www.elektro.net](http://www.elektro.net)).

**Cable trunks** are enclosed components, usually rectangular, made either of plastic or of metal, which are used to protect and route cables orderly over a room's surface. They can be mounted vertically as well as horizontally, and are a common solution for cable deployment in existing buildings.<sup>100:101</sup>

**Cable trays or mesh trays** are open cable pathways used for horizontal laying of cables, typically deployed in basements. Accessibility considerations after their installation must be taken into account.<sup>102</sup>

<sup>98</sup> BMVI (2021). ‚Bausteine für Netzinfrastrukturen von Gebäuden‘, p.42.

<sup>99</sup> BMVIT (2017). ‚Planungsleitfaden Indoor Technischer Leitfaden zur Planung und Errichtung von gebäudeinternen passiven Breitbandinfrastrukturen, p. 28.

<sup>100</sup> BMVIT (2017). ‚Planungsleitfaden Indoor Technischer Leitfaden zur Planung und Errichtung von gebäudeinternen passiven Breitbandinfrastrukturen, p. 29.

<sup>101</sup> Digital Gipfel (2020). ‚Leitfaden zur Errichtung von Glasfasergebäudenetzen‘. Handreichung der Fokusgruppe „Digitale Netze“ Plattform „Digitale Netze und Mobilität“, p. 13.

<sup>102</sup> BMVIT (2017). ‚Planungsleitfaden Indoor Technischer Leitfaden zur Planung und Errichtung von gebäudeinternen passiven Breitbandinfrastrukturen, p. 29.

Figure 4-13: Cable trunks and trays



Source: BMVIT (2017). 'Planungsleitfaden Indoor Technischer Leitfaden zur Planung und Errichtung von gebäudeinternen passiven Breitbandinfrastrukturen, p. 29.; Easttech (2022). <http://www.easternuae.com/Eastech/cable-management-system/pvc-dado-trunking-system>. Last accessed: 28.11.2022.

#### Other forms    Special ducts and cables

**Adhesive fibre systems:** They have a reduced bend radius, allowing tight bends in the fibre with low risk of attenuation loss. They can practically be 'glued' around baseboards, windows and trim work, providing a rapid, flexible and almost invisible installation of fibre cables inside the building. This portable system can be used for almost any indoor installation. It reduces the equipment costs and is an aesthetically appealing "on-the-wall" alternative when shafts are congested.<sup>103</sup>

**Small Diameter Drop Cables** are smaller than one millimetre and are ideal for horizontal applications during the "homes passed" phase of the roll-out, especially design to connect the wall outlet inside an apartment unit with the floor distributor box, which is typically located in the utility shaft. As this routing path can be complicated, small diameter cables with a high tensile strength allow a rapid and secure pulling of the cable through congested ducts or pipes, resulting lower installation costs.<sup>104</sup>

### The role of standardisation

Standards set minimum requirements regarding the performance and structure of the in-building infrastructure. In the absence of any binding specifications or standards, the actual implementation could vary from one building to the next, resulting in unpredictable differences in the in-building infrastructure. The uncertainty regarding the extent, to which end-customers can be accessed and, ultimately at what cost, may negatively impact investment decisions on whether Fibre-to-the-Home (FTTH) is deployed.<sup>105 106</sup>

<sup>103</sup> FTTH Council Europe (2018). FTTH Handbook Edition 8. D&O Committee. Revision Date: 13/02/2018, p. 87.

<sup>104</sup> FTTH Council Europe (2018). FTTH Handbook Edition 8. D&O Committee. Revision Date: 13/02/2018, p. 86.

<sup>105</sup> Batura, O., Plückebaum, T. and Wissner, M. (2018). 'Study on Implementing and monitoring of measures under Directive 61/2014 (Cost Reduction Directive) – SMART 2015/0066, pp. 92 and 106-107.

<sup>106</sup> In order to diminish uncertainty about the state of in-building infrastructure, there has been some market oriented initiatives to minimize information asymmetries. For instance through the introduction of different seals (labels) of quality (gold, silver, bronze) that makes transparent whether the new or renovated residential or commercial properties has a future-proof broadband cabling, recognizing the added value to the property (dibkom, 2017. 'Gütesiegel Breitband'. <https://dibkom.net/quetesiegel-breitband/>. Last accessed: 29.11.2022).

Additionally, if there are no standards defining the location of access point and how it is designed, infrastructure-based competition is unlikely to develop.<sup>107</sup> Yet, standards on information technology cabling systems are not binding in Germany, thus they are often not applied in the construction of new buildings.<sup>108</sup> It would be desirable to require mandatory use of standards, so that the market stakeholders (planners, building owners, installation companies and access network infrastructure providers) know, what to expect.

There are different standards for the two types of passive in-building infrastructure:

- Cables and connectors
- Cable pathways

Table 4-2: Overview of the relevant international standards for in-building passive infrastructure for cable, connectors and cable pathways

	Standard	Description
<b>Cables and connectors</b>	ISO/IEC 11801	Generic cabling for customer premises
	EN 50173	Generic cabling systems
<b>Cable pathways</b>	ISO/IEC 18010	Pathways and spaces for customer premises cabling
	IEC 61084	Cable trunking systems and cable ducting systems for electrical installations
	IEC 61386	Conduit systems for cable management
	IEC 61537	Cable management – Cable tray systems and cable ladder systems

Source: WIK.

### Standards for cables and connectors

In the past, any system change led to new cabling requirements, as each system supplier was tied up to its own cabling and connector systems. With standards on communication protocols

<sup>107</sup> Batura, O., Plückebaum, T. and Wisser, M. (2018). 'Study on Implementing and monitoring of measures under Directive 61/2014 (Cost Reduction Directive) – SMART 2015/0066, pp. 106-107.

<sup>108</sup> In Germany, there is no mandatory cabling standard or mandatory use of a pathway and spaces system. Decisions are left to investors and their architects. The German Electrotechnical Association (VDE, Technisch-wissenschaftlicher Verband der Elektrotechnik und Elektronik) has defined a voluntary application rule VDE-AR-E 2800-901 for connecting homes to FTTB and FTTH infrastructures (Batura, O., Plückebaum, T. and Wisser, M. (2018). 'Study on Implementing and monitoring of measures under Directive 61/2014 (Cost Reduction Directive) – SMART 2015/0066, pp. 105-106). This voluntary rule is based on concepts of application-neutral communication cable systems according to the standards of the DIN EN 50173 series (DKE - Deutsche Kommission Elektrotechnik Elektronik Informationstechnik in DIN und VDE, 2022. 'Normen & Standards: VDE-AR-E 2800-901 (VDE -AR-E 2800-901):2009-12'. <https://www.dke.de/de/normen-standards/dokument?id=3021047&type=dke%7Cdokument>. Last accessed: 29.11.2022).

and infrastructure, a reduced number of infrastructure components can be used to support a wide range of different systems and applications.<sup>109</sup>

The ISO/IEC 11801 standard defines channel classes with upper frequency thresholds. Establishing a channel<sup>110</sup> at a given frequency threshold can be performed by certain types of cable and connectors that follow a specific physical cable construction and shielding. These cables and connectors are grouped accordingly in categories (see Table 4-3Table 4-1).<sup>111</sup>

Table 4-3: ISO/IEC 11801: channel classes and their corresponding cable and connector categories

Channel	Frequency [MHz]	Cable/ Connector
Class A	0,1	Category 1
Class B	1	Category 2
Class C	16	Category 3
Class D	100	Category 5
Class E	250	Category 6
Class E <sub>A</sub>	500	Category 6 <sub>A</sub>
Class F	600	Category 7
Class F <sub>A</sub>	1.000	Category 7 <sub>A</sub>
Class I	1.600 – 2.000	Category 8.1
Class II	1.600 – 2.000	Category 8.2

Source: WIK based on Batura, O., Plückebaum, T. and Wisser, M. (2018). 'Study on Implementing and monitoring of measures under Directive 61/2014 (Cost Reduction Directive) – SMART 2015/0066, p. 236.

Over time the capacity per channel has increased. Lower category cables and connectors have been sufficient for certain applications, but for today's applications (up to 10 Gbit/s) at least Category 6 – 6<sub>A</sub> cables and connectors are required.<sup>112</sup> Yet, when in-building links have connectors and cables of different categories, the channel capacity is determined by the lowest category used in the link. Thus, setting higher standardised categories for all cables and connectors within the building, avoids re-assembly works and enables the use of a wider range of applications.

<sup>109</sup> Batura, O., Plückebaum, T. and Wisser, M. (2018). 'Study on Implementing and monitoring of measures under Directive 61/2014 (Cost Reduction Directive) – SMART 2015/0066, pp. 91-92.

<sup>110</sup> A channel is 'the end-to-end transmission path connecting any two pieces of application-specific equipment' (FDIS 15018 © ISO/IEC:2004 (E), 'Definitions and Abbreviations', p. 14).

<sup>111</sup> Batura, O., Plückebaum, T. and Wisser, M. (2018). 'Study on Implementing and monitoring of measures under Directive 61/2014 (Cost Reduction Directive) – SMART 2015/0066, p. 235.

<sup>112</sup> Batura, O., Plückebaum, T. and Wisser, M. (2018). 'Study on Implementing and monitoring of measures under Directive 61/2014 (Cost Reduction Directive) – SMART 2015/0066, p. 242.

## Standards for cable pathways

In absence of standards, FTTH network investor is often confronted with a wide range of heterogenous practices applied on in-building infrastructure. In the worst case scenario, they may encounter old unshielded telephone copper pairs inside the building's walls deployed without any duct or similar routing component. The uncertainty about the type of in-building infrastructure they have to deal with, not only makes it difficult to predict its renovation costs but also undermines their investment incentive. On the contrary, when binding standards are in place, applications that can be supported by existing in-building infrastructure can be identified at a relatively low cost. Thus, it can be determined more easily whether a new infrastructure is recommended or required, and how much it could cost.<sup>113</sup>

Cable trunking and ducting systems help to organise and route cables throughout the building, offering flexibility for future updates. Whereas there is a wide variety of cable trunking and ducting systems (see 'types of cable pathways' in Section 4.3.2), the standards on cable pathways summarizes the best practice for the use of cable trunking and ducting systems under different routing techniques (surface, mounted, suspended, embedded, etc.), pointing out construction aspects (i.e. cable load capacity, permissible bending radius, protection against mechanical pressure, fire resistance etc.) that should be taken into account (see IEC 61084-1 Cable trunking and ducting systems for electrical installations, part 1: General requirements). It is worth noticing that these standards cover both copper and fibre cables.<sup>114</sup>

Figure 4-14: Overview of cable trunking and ducting systems

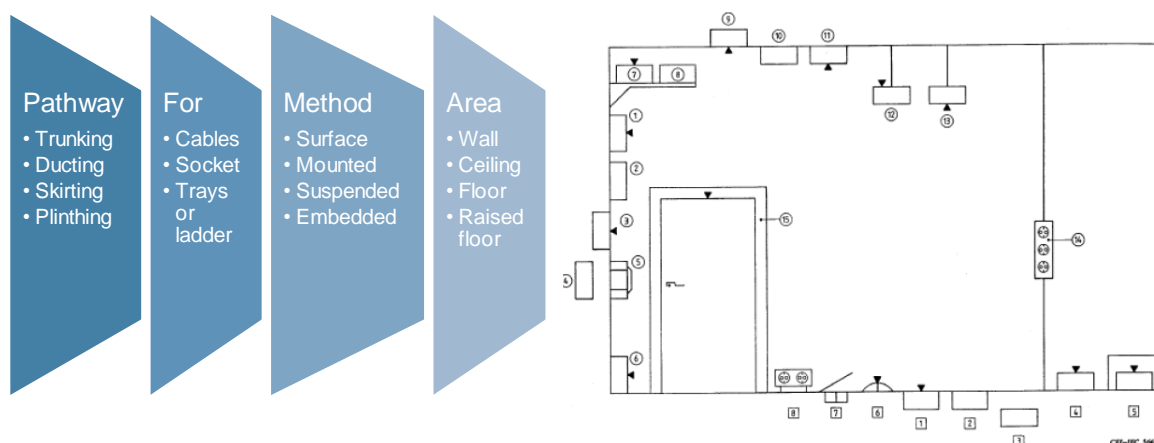

Source: WIK based on IEC 61084-1 Cable trunking and ducting systems for electrical installations and (see Batura, O., Plückebaum, T. and Wisser, M. (2018). 'Study on Implementing and monitoring of measures under Directive 61/2014 (Cost Reduction Directive) – SMART 2015/0066, p. 238).

<sup>113</sup> Batura, O., Plückebaum, T. and Wisser, M. (2018). 'Study on Implementing and monitoring of measures under Directive 61/2014 (Cost Reduction Directive) – SMART 2015/0066, p. 92.

<sup>114</sup> Batura, O., Plückebaum, T. and Wisser, M. (2018). 'Study on Implementing and monitoring of measures under Directive 61/2014 (Cost Reduction Directive) – SMART 2015/0066, pp. 237-239.



## Recommendations for new and extensive renovated buildings

The German Ministry of Transport and Digital Infrastructure and the Focus group "Digital Networks" from the German Ministry of Economy and Energy have published non-binding guidelines for a future-proof deployment of optic fibre cables in building networks.

These guidelines are motivated by the new regulation on network infrastructure for new and extensive renovated buildings in Germany (§ 145 TKG 2021, paragraph 4 and 5, see Section 4.1). They contain recommendations that are neither standards, nor norms. Yet, they intend to provide guidance to proprietors, architects and landlords on which of the numerous equipment variants of in-building networks are up-to-date and sustainable, as these are not specified by law.<sup>115</sup>

This section summarizes these recommendations.

**Cable ducts.** The use of M25<sup>116</sup> electrical installation ducts is advisable. Not only fibre and microducts can be roll-out in an M25 wide electrical installation duct but also copper pairs, coaxial cables, which enables the operation of parallel networks if necessary. When used for the first time, only around 50 percent of the usable cross-sectional area of the electrical installation ducts should be occupied by cables (according to VDE 0100-520, Supplement 1), unless the electrical installation duct is used for micro ducts.<sup>117</sup>

**Micro ducts.** To carry out fibre cables within the M25 electrical installation duct mentioned above, 7/4<sup>118</sup> microducts should preferably be used. As fibre cables can be easily pulled through, micro duct networks are the most future-proof solution for any required exchange, addition or upgrade of fibre cables. Investment costs can be spread over longer periods of time and dark fibre costs can be avoided.<sup>119</sup>

**Cable dimensioning.** For pure residential units in residential buildings is recommended to supply each housing unit with at least two optical fibres.<sup>120</sup>

**Other components.** There is a large number of different connectors for fibre cables (see Figure 4-15). In order to avoid incompatibility and spare unnecessary re-assembly work, the use of LC-APC connectors is recommended. LC-APC connectors achieve high optical quality and thus universality. Additionally, among LC-APC connectors, the quality class B (average

---

<sup>115</sup> BMVI (2021). ‚Bausteine für Netzinfrastrukturen von Gebäuden‘, p. 5.

<sup>116</sup> Diameter 25 mm.

<sup>117</sup> BMVI (2021). ‚Bausteine für Netzinfrastrukturen von Gebäuden‘, pp.40-41.

<sup>118</sup> Nomenclature for outer/inner diameter of microducts in mm.

<sup>119</sup> FTTH Council Europe (2018). FTTH Handbook Edition 8. D&O Committee. Revision Date: 13/02/2018, p. 85.

<sup>120</sup> Digital Gipfel (2020). ‚Leitfaden zur Errichtung von Glasfasergebäudenetzen‘. Handreichung der Fokusgruppe „Digitale Netze“, Plattform „Digitale Netze und Mobilität“, p. 6.

attenuation loss: 0,12 dB per connection) is recommended according to the EN 61755-1 standard.<sup>121</sup>

Figure 4-15: Fibre cable connectors

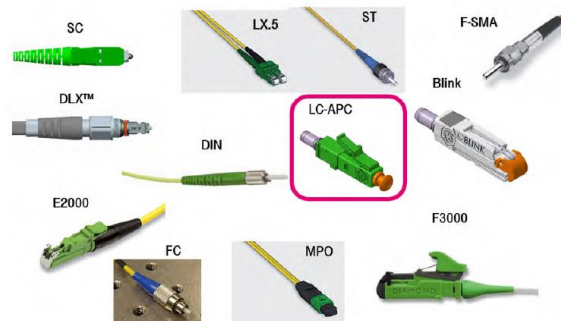

Source: Digital Gipfel (2020). ‚Leitfaden zur Errichtung von Glasfasergebäudenetzen‘. Handreichung der Fokusgruppe „Digitale Netze“, Plattform „Digitale Netze und Mobilität“, p. 22.

### Reducing costs Pre-assembled products

In comparison to any form of copper cable, fibre is inherently more difficult to join in a single cable as the fibre cores have to be aligned to sub-micron accuracy during the splice process. Since the number of splices required in multi-dwelling deployments may be high, the installation costs may significantly increase. In general, the more pre-configuration the assemblies have, the greater the opportunity for saving costs.<sup>122</sup>

**The use of pre-assembled products** is now trending, as they limit the amount of work required for assembly, allowing faster installation and freeing skilled workers for more productive purposes. Whether and to what extent pre-assembled products can be used depends on the particular circumstances:<sup>123</sup>

**Preloaded microducts.** The cables and plugs for installing a fibre optic connection in the apartment are already pre-loaded in the micro duct. They do not require splicing nor blowing work, reducing the installation time. This solution is particularly beneficial in risers as each individual cable can be branched off directly without the need for blowing and splicing into each apartment.

### Considerations regarding the lack of VHC-network deployment (at NE3)

**If no VHC network infrastructure (FTTB/H or DOCSIS) is available:** the conduit equipment and cable pathways should be dimensioned in such a way that glass and/or coaxial networks

<sup>121</sup> Digital Gipfel (2020). ‚Leitfaden zur Errichtung von Glasfasergebäudenetzen‘. Handreichung der Fokusgruppe „Digitale Netze“, Plattform „Digitale Netze und Mobilität“, p. 22.

<sup>122</sup> FTTH Council Europe (2018). FTTH Handbook Edition 8. D&O Committee. Revision Date: 13/02/2018, pp.55-56.

<sup>123</sup> BMVI (2021). ‚Bausteine für Netzinfrastrukturen von Gebäuden‘, pp.43-44.

can be supported in the future. This comprises following the recommendations mentioned above (7/4 micro ducts and an M25 electrical installation ducts). In absence of fibre or coaxial based access networks (NE3), a copper pair in-in-building network infrastructure (routed in the aforementioned M25 electrical installation duct) can be deployed as an interim solution.<sup>124</sup>

**If only coaxial provider (DOCSIS) is available**, it is technically feasible to deploy and use the in-building fibre network infrastructure, by converting the coaxial cables incoming electrical signals into optical ones.<sup>125</sup> Nevertheless, this solution is technically complex and hard to operate.<sup>126</sup> Thus, in this scenario it is also advisable to use a cable trunking and ducting system that offers enough space for the three infrastructures (i.e. 7/4 micro ducts and an M25 electrical installation ducts).

### 4.3.3 Upgrading in-building infrastructure

When considering and planning in-building cabling upgrades the existence of pathway systems reduce the cost of exchanging the telecommunication infrastructure, but it remains a major effort.<sup>127</sup> Often the new infrastructure has to be deployed in parallel before taking the old out of service. Furthermore, at least some construction work is needed to open and close the fire protection enclosures, which contributes significantly to costs in large residential and business buildings.

Some network providers offer technical planning and installation of fibre cables within the building, from the basement up to the individual apartment, often without replacing the old copper wires. That means that an additional in-building cabling system based entirely on fibre will run parallel to the already existing copper or coaxial cabling systems. For that purpose, following cable pathways alternatives are possible:

- deployment through existing empty ducts,
- deployment through available installation or utility shafts,
- installation of metal ducts along the building's staircase,
- or, as last resort, the deployment of new cables on the exterior façade.<sup>128 129</sup>

---

<sup>124</sup> BMVI (2021). ‚Bausteine für Netzinfrastrukturen von Gebäuden‘, p.14.

<sup>125</sup> BMVI (2021). ‚Bausteine für Netzinfrastrukturen von Gebäuden‘, p.15.

<sup>126</sup> The converters from coax to glass must be set up and operated, including interference suppression.

<sup>127</sup> Especially when existing buildings are under ‘monument protection’ and the historical building fabric cannot be changed. Yet, it is still possible to set up an electrotechnical infrastructure that can supply the building with data and communication connections without interfering with the historical building fabric (Elektropraktiker, 2010. ‘Installationslösungen für historische Gebäude’. Berlin 64 (2010) 4).

<sup>128</sup> DTAG (2020). ‘Glasfaser Wohnungswirtschaft Stuttgart’. Last accessed: 18.11.2022.

<sup>129</sup> Digital Gipfel (2020). ‘Leitfaden zur Errichtung von Glasfasergebäudenetzen’. Handreichung der Fokusgruppe „Digitale Netze“ Plattform „Digitale Netze und Mobilität“, p. 13.

In the end, it depends on the type of building which solution is implemented.

In the ideal scenario, the building is equipped with an empty duct system. Empty duct systems not only facilitate assembly but also allow a rapid fault repair once installed.<sup>130</sup> While it can be relatively cheap to deploy an empty duct system during the construction phase,<sup>131</sup> they are not common in existing old buildings. Yet, if empty ducts systems are available in the building, network providers may have the following requirements:<sup>132</sup>

- Empty ducts with a minimum diameter of 10 mm<sup>133</sup>
- Ducts with a smooth inside and without corrugation+
- Minimum bend radius: 60 mm
- No use of ducts elbows

Additionally, each apartment should have least one empty duct. If routed without tight bends, it should be possible to easily pull the cable through.<sup>134</sup>

#### 4.3.4 Safety regulations on in-building cable deployment

##### **Safety regulation for cables**

In Germany, fire protection regulation is competency of the state. This is embedded in each state building regulations or LBO (*'Landesbauordnung'*). These regional regulations are inspired by a federal reference building regulation or MBO (*'Musterbauordnung'*), which is drafted by the federal state. Thus, federal MBO is the basis for regional LBOs, yet the latter may vary in the specification of following items:

- buildings of different sizes (building classes 1 to 5),
- buildings by type and use,

---

<sup>130</sup> Deutsche Telekom Technik (2016). 'Zielbild zur Installation von zukunftsfähigen Glasfasernetzen in Gebäuden. Ratgeber für Planung und Bau', FTTH-Teilprojektgruppe Basisinfrastruktur (BIS), p.20.

<sup>131</sup> DTAG (2022). Glasfasertipps für den Hausbau: Highspeed-Netze vom Keller bis in die Wohnung (1/4).

<sup>132</sup> Deutsche Glasfaser (2022). 'Glasfaser, Leerrohr und Leitungsweg – So wird der Anschluss vorbereitet'. <https://www.deutsche-glasfaser.de/glasfaser/leitungswege/>. Last accessed: 25.11.2022.

<sup>133</sup> Deutsche Telekom requires empty ducts of min. between 20 and 25 mm outer diameter or alternatively SpeedNet ducts inner (SNRi), which is newer type of microduct system that is very easy, flexible and fast to install. Their ducts have an outer diameter of 7 mm (DTAG, 2021. 'Der modern Hausanschluss hat viele Vorteile Ratgeber für Bauherren/Eigentümer zur Vorbereitung für den Anschluss an das Glasfasernetz', p.8).

<sup>134</sup> Deutsche Telekom Technik (2016). 'Zielbild zur Installation von zukunftsfähigen Glasfasernetzen in Gebäuden. Ratgeber für Planung und Bau', FTTH-Teilprojektgruppe Basisinfrastruktur (BIS), p.20.

- buildings with a special type and use (the so-called special buildings, such as high-rise buildings, industrial buildings, meeting places, accommodation facilities, dormitories or hospitals).<sup>135</sup>

In its § 26, paragraph 1, the MBO specifies the minimum requirements and tolerable limits of flammability for building material and components.<sup>136 137</sup>

*'building materials that are not at least normally flammable (easily flammable building materials) may not be used unless they become not easily flammable when combined with other building materials'*

This means that either i) cables without fire protection may only be used in an installation duct with fire protection properties (e.g. fire-retardant) or ii) cables with improved fire protection properties are used, so long they are laid under plaster or in metal cable ducts in accordance with the simplification of the 'reference model for cable systems' guidelines ('Musterleitungsanlagenrichtlinie').<sup>138</sup>

The flammability degree of building products is determined by the European Construction Products Regulation (BauPVO). The flammability of cables is rank in different fire categories according to their flame resistance, smoke development and acidity based on standardized test methods. The fire categories, also known as 'Euroclass' (EN 13501-6), ranges from the safest category, class A<sub>ca</sub> "non-combustible", to the least safe category, class F<sub>ca</sub> "combustible - easily flammable" (see Figure 4-16).<sup>139</sup>

---

<sup>135</sup> BMVI (2021). ‚Bausteine für Netzinfrastrukturen von Gebäuden‘, p.45.

<sup>136</sup> BMVI (2021). ‚Bausteine für Netzinfrastrukturen von Gebäuden‘, p.44.

<sup>137</sup> Other relevant articles in the MBO are § 14 Fire Protection, general requirements ('Brandschutz), § 67 Exemptions, approval process ('Abweichungen'), § 85 norms ('Rechtsvorschriften').

<sup>138</sup> Digital Gipfel (2020). ‚Leitfaden zur Errichtung von Glasfasergebäudenetzen‘. Handreichung der Fokusgruppe „Digitale Netze“, Plattform „Digitale Netze und Mobilität“, p. 17.

<sup>139</sup> BMVI (2021). ‚Bausteine für Netzinfrastrukturen von Gebäuden‘, p.46.

Figure 4-16: Flammability and Euronorm classification

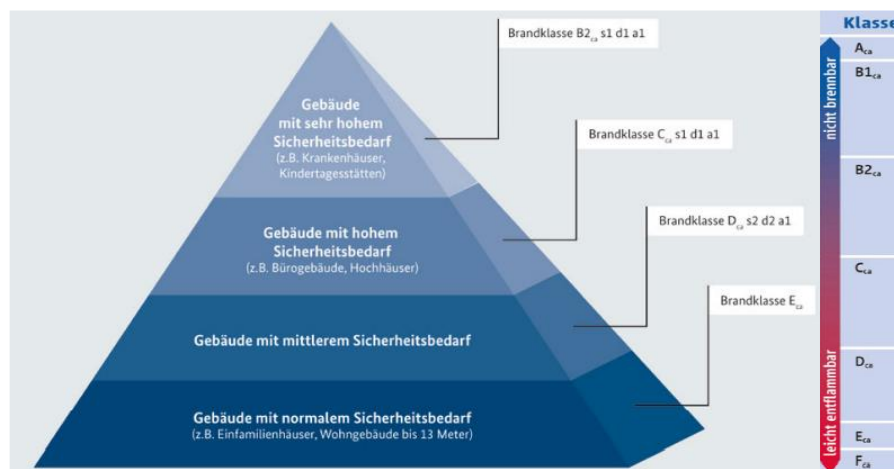

Source: BMVI (2021). ‚Bausteine für Netzinfrastrukturen von Gebäuden: Eine Handreichung der PG-Technik der UAG Inhouse des Bundesministeriums für Verkehr und digitale Infrastruktur.‘ pp.46-47 (originally from the Gigabitbüro des Bundes, modified from: ZVEI e. V. „White Paper: Brandschutzkabel erhöhen die Sicherheit“ vom August 2018).

Thus, cables must comply with the following standards:

- at least Euro class **E<sub>ca</sub>** (e.g. in buildings up to 13 m high).<sup>140</sup>
- EU standard EN50399/ EN13501-6.

As electrical installation ducts and micro ducts do not fall within the scope of BauPVO, they are not classified in fire classes. Instead they are subject to a further regulation (see ‘safety regulation for ducts systems’ below).

### Safety regulation for ducts systems

MLAR (*‘Musterleitungsanlagenrichtlinie’*) is another provision of the building code that has an impact on the fire safety of in-building infrastructures. The norm mainly regulates how empty ducts (i.e. micro ducts, electrical installation ducts) are routed in escape routes (i.e. necessary corridors and stairwells) and through room-enclosing components (walls, ceilings, supports, beams, doorways, etc.).

**Escape routes.** Cable routing systems may be installed in load-bearing, stiffening or space-enclosing components as well as in installation shafts and ducts, so long the necessary fire resistance is maintained. In safety stairwells and in rooms between safety stairwells and

<sup>140</sup> BMVI (2021). ‚Bausteine für Netzinfrastrukturen von Gebäuden‘, p.46.

building's exits cable routing systems are only permitted, if they serve the purpose of directly supplying these rooms or fight fires.<sup>141</sup>

**Room-enclosing components.** Relevant building components (walls, ceilings, supports, beams, doorways, etc.) are classified into basic fire resistance classes, depending on the amount of time they are capable of resisting fire (in minutes). In principle, in the event of fire, building components are required to offer a minimum of protection and prevent the fire from spreading throughout the building for long enough such that the building can be evacuated. For this purpose, fire compartment-forming walls and ceilings are not allowed to be interrupted. Instead, for necessary supply installations, openings must be created. At these openings, installers must take appropriate compensatory measures to restore their fire resistance. This can be achieved by implementing fire barriers, ventilation flaps, etc. Appropriate specialist companies, in coordination with the architects of the building, are the indicated one in meeting these type of requirements.<sup>142</sup>

In general, the details of the regulations depend upon the particularities of the building and the used components. For instance, the insulation requirements are specified according to the thickness of the wall or the ceiling and on the properties of the empty duct.<sup>143</sup>

In practise, the deployment of duct systems requires following common considerations:

- Pre-existing plastic ducts throughout the building's escape routes (i.e. stairwells and corridors) cannot be used for the deployment of fibre within the building according to the local construction regulations. New ducts made of metal are required instead.<sup>144</sup>  
<sup>145</sup>
- Duct networks in escape routes (i.e. corridors and/or stairwells) must be laid under plaster and e.g. be covered with 15 mm thick mineral plaster.<sup>146</sup>
- The bulkhead systems may only be installed individually and must be approved individually. A building authority test certificate is required, if electrical installation ducts and micro ducts are routed through a firewall. The ducts should be sealed smoke-tight at the ends.<sup>147</sup>

---

<sup>141</sup> Deutsche Institut für Bautechnik (2021). ‚Muster-Leitungsanlagen-Richtlinie MLAR‘. Fachkommission Bauaufsicht der Bauministerkonferenz, Fassung 10.02.2015 zuletzt geändert durch Beschluss der Fachkommission Bauaufsicht vom 03.09.2020. Amtliche Mitteilungen Nr. 3/30.04.2021, pp. 5-6.

<sup>142</sup> BMVI (2021). ‚Bausteine für Netzinfrastrukturen von Gebäuden‘, pp. 49-51.

<sup>143</sup> BMVI (2021). ‚Bausteine für Netzinfrastrukturen von Gebäuden‘, pp. 49-51.

<sup>144</sup> DTAG (2020). ‚Glasfaser Wohnungswirtschaft Stuttgart‘. Last accessed: 18.11.2022.

<sup>145</sup> Digital Gipfel (2020). ‚Leitfaden zur Errichtung von Glasfasergebäudenetzen‘. Handreichung der Fokusgruppe „Digitale Netze“ Plattform „Digitale Netze und Mobilität“, p. 13.

<sup>146</sup> Digital Gipfel (2020). ‚Leitfaden zur Errichtung von Glasfasergebäudenetzen‘. Handreichung der Fokusgruppe „Digitale Netze“ Plattform „Digitale Netze und Mobilität“, p. 13.

<sup>147</sup> BMVI (2021). ‚Bausteine für Netzinfrastrukturen von Gebäuden‘, pp. 49-51.

### 4.3.5 Highlights

#### Deploying fibre and upgrading in-building infrastructure

##### Opportunities

- **The sky is the limit.** By extending fibre into the in-building infrastructure the theoretically unlimited capacity of fibre cables can be fully exploited. Whereas the current optical equipment currently limits the capacity of optical fibre in access networks to gigabit speeds between 1 to 25 Gbps, in the future, further upgrades cannot be ruled out.
- **Increased adaptability.** In contrast to copper cables, fibre can be blown in into the building, allowing a quicker reaction to changes in the demand at a relatively low cost. Particularly flexible is the infrastructure, when the recommended M25 electrical installation ducts with 7/4 micro ducts is used in combination with standardised passive in-building cabling system (i.e. cable, connectors and cable pathways).
- **Boost competition.** Due to its physical properties, fibre is not affected by electromagnetic interferences, allowing the undisturbed use of individual fibres within a cable by one or multiple network provider. When used in a Point-to-Point (PtP) in-building architecture, fibre cable can easily be unbundled. This enables and supports the physical access to the building, opening up the building for competition among network providers.

##### Limitations

- In Germany, the expansion of fibre-based networks is not constrained by technical reasons. However the legal obligation of § 145 para 4 and 5 TKG to equip newly erected buildings and buildings which are extensively renovated with suitable passive network infrastructure for very high capacity networks and an access point to these passive network elements inside the building is not properly enforced.



## 5 Summary and conclusions

While benefits of fibre optic expansions in the form of Fibre-to-the-Curb (FTTC) or Fibre-to-the-Building (FTTB) are reaching their limits, the in-building infrastructure is today, more than ever, critical for an effective gigabit policy that truly impacts the end user.

The wide availability of existing in-building cabling (either copper or coaxial cables) cannot support the gigabit targets set by the German government even if competition practices of sharing in-building cabling would be common place. Fibre cables are needed to reach those target and opening up the building for competition through physical unbundling should not be the exemption but the rule, yet these copper-based networks are not capable to achieve that.

We start the technical analysis of this paper by describing the possibility of reaching gigabit speeds on the old telephone copper wires with XG.fast. Yet, the shared use of existing in-building copper cables comes at the cost of losing signal quality. Thus, with copper pair cables, competition (through physical unbundling) and symmetrical gigabit speeds may be attainable goals, which can be pursued separately (either – or) but not together.

Moving on to the second most common form of in-building cable deployment, coaxial cables, it became clear that while quality loss is no longer an issue, physical unbundling coaxial cables is only possible to a limited extent, in certain circumstances and with constrained results. Unbundling coaxial cables requires individual coax cables, which represent an in-building cabling topology that is widely uncommon in residential units in Germany. An alternative solutions, i.e. MoCA, which is mostly used in North America, is not practical in Germany, as it requires coaxial cables that are capable of supporting frequencies of at least 1,8 GHz. Without further investments, they are rarely available today and their implementation is not foreseeable in the near future.

Fibre optic in-building cables deployed in a Point-to-Point topology can reliably deliver symmetrical gigabit speeds to the end user. At the same time, it allows the sharing of in-building infrastructure and physical unbundling enabling a competitive environment. This future-proof technology do not present any of the problems and restrictions faced by the aforementioned copper-based in-building infrastructure. These advantages can rapidly vanish if the selected in-building cabling topology for the fibre deployment corresponds a Point-to-Multipoint (PtMP) with cascade splitters.

Finally, we want to stress the importance of setting binding standards for cables and cable routing pathways in the deployment and renovation of in-building infrastructure. They not only make the require investment more predictable but also facilitate upgrade of the in-building infrastructure to very high capacity networks (VHCN) and ultimately increase their adaptability to future developments. A round table of stake holders could define those standards. Some elements of this paper may be used as a starting point for such a process.

## Literature

- Batura, O., Plückebaum, T. and Wisser, M., (2018). 'Study on Implementing and monitoring of measures under Directive 61/2014 (Cost Reduction Directive) – SMART 2015/0066'. Technical Report. January 2018. DOI: 10.2759/69130
- Braun, M. R., Wernick, C., Plückebaum, T., Ockenfels, M. (2019). , Parallele Glasfaserausbauten auf Basis von Mitverlegung und Mitnutzung gemäß DigiNetzG als Möglichkeiten zur Schaffung von Infrastrukturwettbewerb'. WIK Diskussionsbeitrag Nr. 456.
- Breibandbüro des Bundesministeriums für Verkehr, Innovation und Technologie – BMVIT (2017). 'Planungsleitfaden Indoor. Technischer Leitfaden zur Planung und Errichtung von gebäudeinternen passiven Breitbandinfrastrukturen.
- Bundeministerium für Verkehr und digitale Infrastruktur – BMVI (2021). ,Bausteine für Netzinfrastrukturen von Gebäuden. Breitbandausbau hochgeschwindigkeitsfähiger Inhouse-Netze nach § 77k TKG Abs. 4 (Neubau)'. Eine Handreichung der PG-Technik der UAG Inhouse des Bundesministeriums für Verkehr und digitale Infrastruktur.
- Bundesnetzagentur für Elektrizität, Gas, Telekommunikation, Post und Eisenbahnen (2021). Jahresbericht 2021.
- Bundesnetzagentur für Elektrizität, Gas, Telekommunikation, Post und Eisenbahnen (2020). 'Beschluss 2. Teilentscheidung wegen der Überprüfung der Standardangebote im Zusammenhang mit der Zugangsgewährung zur Teilnehmeranschlussleitung', öffentlicher Fassung, BK3e-15/011.
- Bundesnetzagentur für Elektrizität, Gas, Telekommunikation, Post und Eisenbahnen (2018). 'Beschluss 1. Teilentscheidung wegen der Überprüfung der Standardangebote im Zusammenhang mit der Zugangsgewährung zur Teilnehmeranschlussleitung', öffentlicher Fassung, BK3e-15/011.
- Colmegna, A., Galli, S. and Goldberg, M., (2012). 'Methods for supporting vectoring when multiple services providers share the cabinet area'.
- CORDIAL GmbH (2022). 'Übersprechen oder Crosstalk'. <https://www.cordial-cables.com/de/uebersprechen>. Last accessed. 19.12.2022.
- Deutsche Glasfaser (2022). 'Glasfaser, Leerrohr und Leitungsweg – So wird der Anschluss vorbereitet'. Retrieved from <https://www.deutsche-glasfaser.de/glasfaser/leitungswege/>. Last accessed: 25.11.2022.
- Deutsche Glasfaser (2022). 'Häufige Fragen und Antworten zum Glasfaser-anchluss in Mietwohnungen, wie wird Glasfaser im Haus verteilt?'. Retrieved from <https://www.deutsche-glasfaser.de/mehrfamilienhaeuser/>. Last accessed: 08.12.2022.
- Deutsche Institut für Bautechnik (2021). ,Muster-Leitungsanlagen-Richtlinie MLAR'. Fachkommission Bauaufsicht der Bauministerkonferenz, Fassung 10.02.2015 zuletzt geändert durch Beschluss der Fachkommission Bauaufsicht vom 03.09.2020. Amtliche Mitteilungen Nr. 3/30.04.2021.
- Deutsche Kommission Elektrotechnik Elektronik Informationstechnik in DIN und VDE – DKE, (2022). 'Normen & Standards: VDE-AR-E 2800-901: 2009-12'. Retrieved from <https://www.dke.de/de/normen-standards/dokument?id=3021047&type=dke%7Cdokument>. Last accessed: 29.11.2022.
- Deutsche Telekom AG (2016). 'Zielbild zur Installation von zukunftsfähigen Glasfasernetzen in Gebäuden. Ratgeber für Planung und Bau'. FTTH-Teilprojektgruppe Basisinfrastruktur (BIS).
- Deutsche Telekom AG (2020). 'Glasfaser Wohnungswirtschaft Stuttgart'. 02. June 2020.

- Deutsche Telekom AG (2020). 'Ratgeber zur Installation von Glasfasernetzen in Gebäuden'. Wissensspeicher. Version 2.0.
- Deutsche Telekom AG (2021). 'Der modern Hausanschluss hat viele Vorteile Ratgeber für Bauherren/Eigentümer zur Vorbereitung für den Anschluss an das Glasfasernetz'.
- Deutsche Telekom AG (2022). 'Glasfaserkabel als Lichtwellenleiter für schnelles Internet'. Retrieved from <https://www.telekom.com/de/konzern/details/glasfaserkabel-als-lichtwellenleiter-fuer-schnelles-internet-612108>. Last accessed: 18.07.2022.
- Deutsche Telekom AG (2022). 'Glasfaserkabel als Lichtwellenleiter für schnelles Internet'. Retrieved from <https://www.telekom.com/de/konzern/details/glasfaserkabel-als-lichtwellenleiter-fuer-schnelles-internet-612108>. Last accessed: 18.07.2022.
- Deutsche Telekom AG (2022). 'Glasfasertipps für den Hausbau: Highspeed-Netze vom Keller bis in die Wohnung (1/4)'. 01. March.2022
- Deutsches Institut für Breitbandkommunikation gGmbH – dibkom (2017). 'Gütesiegel Breitband'. Retrieved from <https://dibkom.net/guetesiegel-breitband/>. Last accessed: 29.11.2022.
- Digital Gipfel (2020). 'Leitfaden zur Errichtung von Glasfasergebäudenetzen'. Handreichung der Fokusgruppe „Digitale Netze“ Plattform „Digitale Netze und Mobilität“.
- eAcademy (2022). 'Breitbandausbau mit Glasfaser: Mikrorohre als Kabelwegsystem'. <https://eacademy.mitegro.de/2022/02/03/breitbandausbau-mit-glasfaser-mikrorohre-als-kabelwegsystem/>. Last accessed: 19.12.2022.
- Easttech (2022). <http://www.easternuae.com/Easttech/cable-management-system/pvc-dado-trunking-system>. Last accessed: 28.11.2022.
- Edpnet (2022). 'What is Vectoring Technology'. <https://www.edpnet.be/en/support/installation-and-usage/internet/learn-about-dsl-configuration/what-is-vectoring-technology.html>. Last accessed: 19.11.2022.
- Elektronik-Kompendium.de (2022). Retrieved from <https://www.elektronik-kompendium.de/sites/kom/index.htm#a2>. Last accessed: 19.12.2022.
- Elektropraktiker (2010). 'Installationslösungen für historische Gebäude'. Berlin 64 (2010) 4.
- European Commission (2021). 'Broadband Coverage in Europe 2021'. <https://digital-strategy.ec.europa.eu/en/policies/desi-connectivity>. Final dataset (.xlsx). Last accessed: 06.10.2021.
- European Commission (2021). 'Annexes to the Guidelines on State aid for broadband networks'. Draft. [https://competition-policy.ec.europa.eu/public-consultations/2021-broadband\\_en](https://competition-policy.ec.europa.eu/public-consultations/2021-broadband_en). Last accessed: 19.12.2022.
- Fibre to the Home Council Europe (2018). 'FTTH Handbook Edition 8'. D&O Committee. Revision Date: 13/02/2018.
- Fränkische Rohrwerke (2022). 'Leerrohrberater für Praktiker. Installationsnormen, -formen, -themen. Brandschutz, Dateninstallation und FAQs', p. 19. <https://docplayer.org/109311475-Installation-qualitaet-normen-leerrohrberater-fuer-praktiker-installationsnormen-formen-themen-brandschutz-dateninstallation-und-faqs.html>. Last accessed: 19.12.2022.
- Frontzeck-Hornke, M. (2014). 'So sieht der derzeitige Sternnetz- und Baumnetz-Ausbau bei den Kabelnetzbetreibern aus'. Retrieved from <https://www.teltarif.de/sternetz-baumnetz-kabel-vorteile-nachteile-vergleich/news/57368.html?page=2>. Last accessed: 23.11.2022.

- Gigabitbüro des Bundes (2022). 'Mehr über Gigabit Technologien erfahren'. Retrieved from <https://gigabitbuero.de/thema/gigabittechnologien/>. Last accessed: 29.11.2022
- Goldmedia GmbH Strategy Consulting (2020). 'Evolution der HFC-Netze bis 2030: Zukunftsfähigkeit der Kabelnetze im Wettbewerb der Gigabit-Infrastrukturen. Kurzstudie. Vodafone Institut für Gesellschaft und Kommunikation.
- Grützner, J. (2022). 'Darf Telekom den Glasfaserausbau mittels Vectoring aushebeln?'. Entscheidung der Bundesnetzagentur zur Inhouse-Verkabelung sorgt für Verunsicherung. VATM. Retrieved from <https://www.vatm.de/inhouse-verkabelung/> Last accessed: 14.12.2022.
- Hamzeh, B. (2016). 'Full Duplex DOCSIS Technology: Raising the Ante with Symmetric Gigabit Service'. Cablelabs. Retrieved from <https://www.cablelabs.com/blog/full-duplex-docsis-3-1-technology-raising-the-ante-with-symmetric-gigabit-service>. Last accessed: 23.11.2022.
- Hewlett-Packard (1995). 'Cross talk in unshielded twisted-pair cables'. *Hewlett-Packard Journal*, August 1995.
- Incoax Networks AB (2019). 'Umwandlung von Kabelnetzen in Multi-Gigabit-Glasfaser-Erweiterungen Chance für HFC-, Telekommunikations und Glasfaserbetreiber'.
- Init7 (2022). 'Warum Internet von Init7'. Retrieved from <https://www.init7.net/de/internet/warum-init7/>. Last accessed: 12.12.2022.
- ISO/IEC (2004). 'ISO/IEC 15018:2004 Information technology — Generic cabling for homes'.
- Kirschkewitz (2022). 'Die Glasfaser-Schule der Telekom: Wie kommt die Glasfaser in die Wohnung (3)'. Retrieved from <https://www.telekom.com/de/blog/netz/artikel/die-glasfaser-schule-der-telekom-wie-kommt-die-glasfaser-in-die-wohnung-3--1007338>. Blog.Telekom vom 31.05.2022. Last accessed: 08.12.2022.
- Kulenkampff, G., Ockenfels, M., Plückebaum, T. Zoz, K., Zuloaga, G. (2022). 'Technische Aspekte der räumlichen Erstreckung von Anschlussnetzen. WIK Diskussionsbeitrag.
- Ljungdahl, A. and Zhao, J. (2012). 'State-of-the-Art and Emerging Multimedia-over-Coax (MoCa) Solutions and Deployments'. *European Conference and Exhibition on Optical Communication*.
- M-net (2022). 'M-Net Hausverkabelung'. Retrieved from <https://www.m-net.de/hausverkabelung/>. Last accessed: 08.12.2022
- Multimedia over Coax Alliance – MoCA (2021). 'Copper Broadband Technology Developments. MDU Connectivity Enhancements. *Conferece 2021 broadband forum*. Retrieved from [https://mocalliance.org/access/MDU-Connectivity-Enhancements\\_MoCA\\_UFBB-Virtual-Conference-2021.pdf](https://mocalliance.org/access/MDU-Connectivity-Enhancements_MoCA_UFBB-Virtual-Conference-2021.pdf). Last accessed: 23.11.2022.
- Multimedia over Coax Alliance – MoCA (2021). FAQs. Retrieved from [MoCA for Installers :: MoCA FAQs \(moca4installers.com\)](https://moca4installers.com). Last accessed: 14.12.2022.
- NetCologne (2022). 'Was ist G.Fast?' Alles zur Internet-Technik. Und ihren Vorteilen'. Retrieved from <https://www.netcologne.de/geschaeftskunden/blog/was-ist-gfast/>. Last accessed: 23.11.2022.
- Obermann, K. (2017). 'Zusammenspiel von G.Fast und Supervectoring. Ist es möglich?'. *BREKO Fibre Conferece* 25.04.2017. Retrieved from <https://www.lwportal.de/mediathek/detail/mediathek-action/display/Item/prof-dr-kristof-obermann-gfast-und-supervectoring.html>. Last accessed: 23.11.2022.
- Open Compute Project (2018). 'G.fast DPU Design - OCP Telecom Workshop @ BCE'.

- Optigo Networks (2019). 'What are passive optical splitters?'. Retrieved from <https://www.optigo.net/what-are-passive-optical-splitters/>. Last accessed: 13.12.2022.
- Plückebaum, T. and Ockenfels, M. (2020). 'Kosten und andere Hemmnisse der Migration von Kupfer- auf Glasfasernetze'. WIK Discussion Paper Nr. 457.
- Plückebaum, T., Eltges, F., Ockenfels M. (2019). 'Potenziell anzunehmende Vorleistungsprodukte in Kabelnetzen auf der Basis von DOCSIS;'. Studie für die Bundesnetzagentur.
- Rödl & Partner (2022). 'DOCSIS 4.0 – echte Alternative zu Glasfaser?'. Retrieved from <https://www.roedl.de/themen/kompass-telekommunikation/2022/10/docsis-vier-null-alternative-zu-glasfaser>. Last accessed: 22.11.2022.
- Sawall, A. (2020). '50 Jahre Glasfaser. Warum der erste Glasfaserausbau der Telekom scheiterte'. Golem Media GmbH. 10. Dezember 2020. Retrieved from <https://www.golem.de/news/50-jahre-glasfaser-warum-der-erste-glasfaserausbau-der-telekom-scheiterte-2012-152748.html>. Last accessed: 22.08.2022.
- Society of Cable Telecommunications Engineers (2017). 'Operational Practise for Coexistence of DOCSIS 3.1 Signals and MoCA Signals in the Home Environment'. Engineering Committee. SCTE Standard, SCTE 235 2017.
- Statistisches Bundesamt – DESTATIS (2022). 'Anzahl der Wohnungen'. Stand: 27.01.2022. Code: 31231-0001.
- United Internet (2019). 'Glasfaser-Anschlüsse: Unterschiede von FTTC, FTTB und FTTH'. Pressemitteilung vom 02.10.2019, 13:49 Uhr. Retrieved from <https://www.united-internet.de/investor-relations/publikationen/meldungen/meldungen-detail/news/glasfaser-anschluesse-unterschiede-von-fttc-fttb-und-ftth.html>. Last accessed: 18.11.2022.
- VIAMI Solutions (2018). 'Installing G.fast in a Multi-Dwelling Unit'.
- Vodafone (2022). 'Vodafone Group Plc. H1 FY23 Results'. Presentation from 15. November 2022. Retrieved from <https://investors.vodafone.com/sites/vodafone-ir/files/2022-11/vodafone-h1-fy23-results-presentation.pdf>. Last accessed: 23.11.2022.
- Vogelsang, A. (2004). 'Modell für Nebensprechstörungen auf xDSL-Leitungen und dessen praktische Umsetzung'.
- Von Hammerstein, A. (2010). 'Zugang zur Inhouse-Verkabelung für NGA aus Sicht der Kabelnetzbetreiber'. Kabel Deutschland. Präsentation für das NGA-Forum der Bundesnetzagentur. Retrieved from <https://docplayer.org/57214899-Zugang-zur-inhouse-verkabelung-fuer-nga-aus-sicht-der-kabelnetzbetreiber.html>. Last accessed: 12.12.2022.

## Annex

For the deployment of inhouse-cabling, the following structural solutions are available:<sup>148</sup>

- multi-riser tree structure
- single-riser tree structure
- star structure

**Multi-riser tree structure.** With a multi-riser ‘tree structure’, each floor distribution box has its own riser cable, through which copper twisted pairs, coaxial cables or optic fibres are routed parallelly. The number of twisted pairs, coaxial cables or optic fibres required in the riser cable depends on the number of apartments and the dimensioning of the cables. The installation of a floor distribution box on every floor is not necessary, as one box can supply several floors.<sup>149</sup>

The multi-riser ‘tree-structure’ is an optimal solution for rather larger buildings, which, due to spatial and economical constraints, the connection of each apartment through an individual and independent drop cable becomes too expensive, time consuming or even technically unfeasible. Instead, the multi-riser ‘tree structure’ solution use multiple central risers to serve larger areas on each floor(s).<sup>150</sup>

**Single-riser tree structure.** The single-riser ‘tree structure’ might be an alternative solution to the multi-riser ‘tree structure’, if the space inside the building is severely constrained. With the ‘single riser’, individual drop cables in each floor are branched out from a single riser duct. Thus, adequate vertical areas, for example on the façade, through existing risers, or sometimes even outside of the building, are required.

---

<sup>148</sup> FTTH Council Europe (2018). FTTH Handbook Edition 8. D&O Committee. Revision Date: 13/02/2018, p.66

<sup>149</sup> Digital Gipfel (2020). ‚Leitfaden zur Errichtung von Glasfasergebäudenetzen‘. Handreichung der Fokusgruppe „Digitale Netze“, Plattform „Digitale Netze und Mobilität“, p. 10

<sup>150</sup> FTTH Council Europe (2018). FTTH Handbook Edition 8. D&O Committee. Revision Date: 13/02/2018, p.79

Figure 0-1: 'Tree structure' solutions for inhouse-cabling

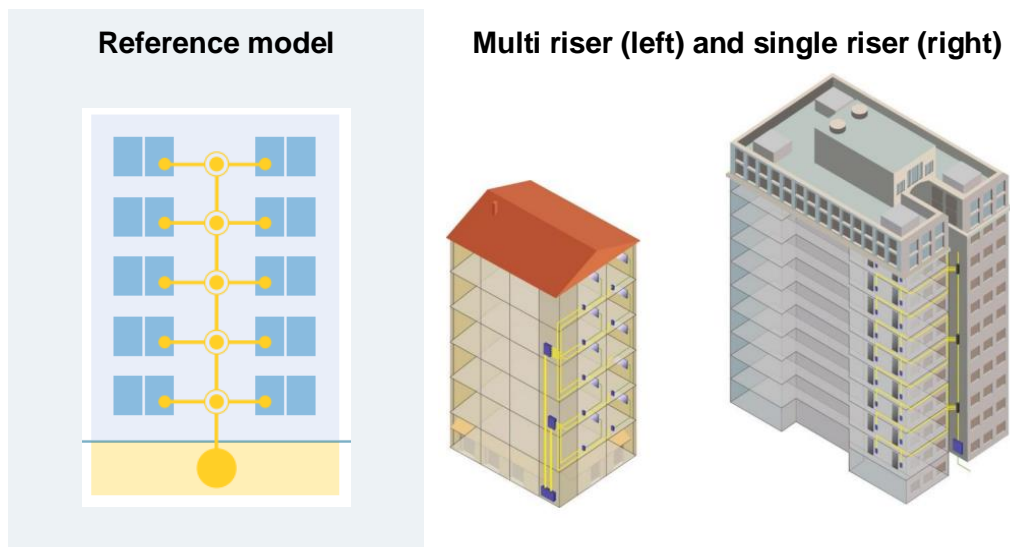

Source: Digital Gipfel (2020). ‚Leitfaden zur Errichtung von Glasfasergebäudenetzen‘. Handreichung der Fokusgruppe „Digitale Netze“, Plattform „Digitale Netze und Mobilität“, p. 10 ; and FTTH Council Europe (2018). ‚FTTH Handbook Edition 8. D&O Committee‘. Revision Date: 13/02/2018, p.78

**Star structure.** 'Star structures' connect subscribers using individual cables between the end-user and a building distribution box located either in the basement or on the lower part of the façade (see Figure 0-2).<sup>151</sup> This way, end-users are directly connected without the intermediation of collecting points, such as 'floor distributors' (FD). This structure is therefore best suited for small multi-dwelling units (up to 12 apartments) with sufficiently large risers.<sup>152</sup>

An advantage of the star structure is the uninterrupted, splice- and connector- free fibre strand within the building, which improves the attenuation and transmission quality behaviour compared to the riser structure.

<sup>151</sup> FTTH Council Europe (2018). FTTH Handbook Edition 8. D&O Committee. Revision Date: 13/02/2018, p.79.

<sup>152</sup> Deutsche Telekom Technik GmbH (2016). 'Zielbild zur Installation von zukunftsfähigen Glasfasernetzen in Gebäuden. Ratgeber für Planung und Bau'. FTTH-Teilprojektgruppe Basisinfrastruktur (BIS).

Figure 0-2: 'Star structure' solutions for inhouse cabling

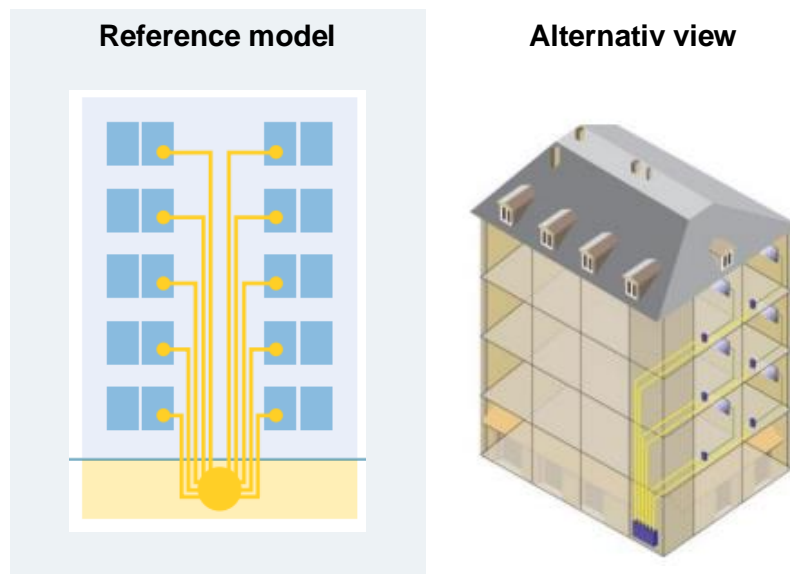

Source: Digital Gipfel (2020). ‚Leitfaden zur Errichtung von Glasfasergebäudenetzen‘. Handreichung der Fokusgruppe „Digitale Netze“, Plattform „Digitale Netze und Mobilität; and FTTH Council Europe (2018). ‚FTTH Handbook Edition 8. D&O Committee‘. Revision Date: 13/02/2018, p.78.



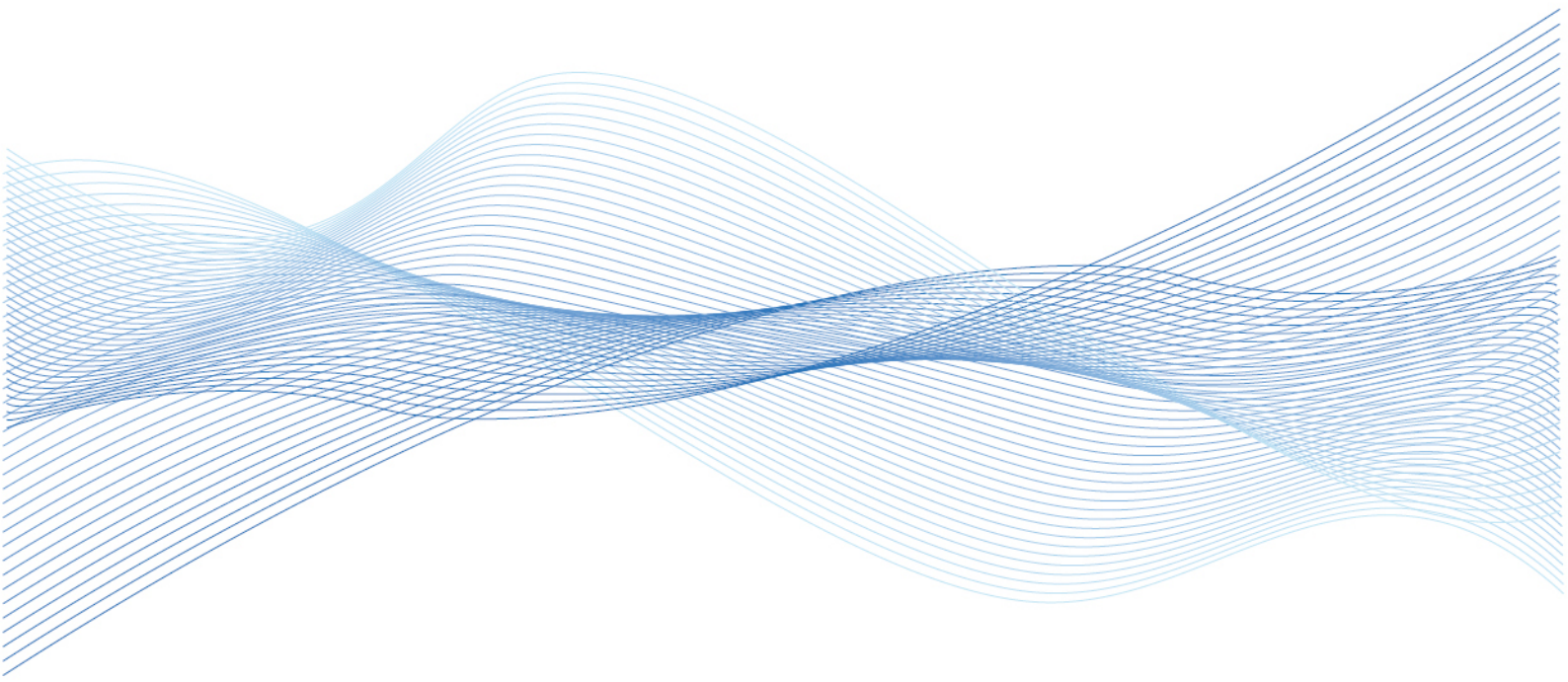

WIK Wissenschaftliches Institut für Infrastruktur  
und Kommunikationsdienste  
Rhöndorfer Str. 68, 53604 Bad Honnef, Germany  
[www.wik.org](http://www.wik.org)

**ISSN 2750-5448 (Online)**