

Rodríguez-Peña, Antonio

Article

Assessing the impact of corporate entrepreneurship in the financial performance of subsidiaries of Colombian business groups: Under environmental dynamism moderation

Journal of Innovation and Entrepreneurship

Provided in Cooperation with:

Springer Nature

Suggested Citation: Rodríguez-Peña, Antonio (2021) : Assessing the impact of corporate entrepreneurship in the financial performance of subsidiaries of Colombian business groups: Under environmental dynamism moderation, Journal of Innovation and Entrepreneurship, ISSN 2192-5372, Springer, Heidelberg, Vol. 10, Iss. 1, pp. 1-27,
<https://doi.org/10.1186/s13731-021-00152-w>

This Version is available at:

<https://hdl.handle.net/10419/259630>

Standard-Nutzungsbedingungen:

Die Dokumente auf EconStor dürfen zu eigenen wissenschaftlichen Zwecken und zum Privatgebrauch gespeichert und kopiert werden.

Sie dürfen die Dokumente nicht für öffentliche oder kommerzielle Zwecke vervielfältigen, öffentlich ausstellen, öffentlich zugänglich machen, vertreiben oder anderweitig nutzen.

Sofern die Verfasser die Dokumente unter Open-Content-Lizenzen (insbesondere CC-Lizenzen) zur Verfügung gestellt haben sollten, gelten abweichend von diesen Nutzungsbedingungen die in der dort genannten Lizenz gewährten Nutzungsrechte.

Terms of use:

Documents in EconStor may be saved and copied for your personal and scholarly purposes.

You are not to copy documents for public or commercial purposes, to exhibit the documents publicly, to make them publicly available on the internet, or to distribute or otherwise use the documents in public.

If the documents have been made available under an Open Content Licence (especially Creative Commons Licences), you may exercise further usage rights as specified in the indicated licence.



<https://creativecommons.org/licenses/by/4.0/>

RESEARCH

Open Access



Assessing the impact of corporate entrepreneurship in the financial performance of subsidiaries of Colombian business groups: under environmental dynamism moderation

Antonio Rodríguez-Peña^{1,2}

Correspondence: a20147476@pucp.pe; arodriguezp@universidadean.edu.co

¹CENTRUM Católica Graduate Business School, Pontificia Universidad Católica del Perú, Jr. Alomía Robles No. 125, Santiago de Surco, Lima, Perú

²Project Management Department, Faculty of Engineering, Universidad Ean, Calle 78 # 11 - 47, Bogotá, D.C., Colombia

Abstract

Corporate entrepreneurship creates opportunities in employment, technological advances, value creation, and cultural transformation for entrepreneurial ecosystems, entrepreneurs, governments, economies, and society around the globe. The purpose of this study is to assess the impact of corporate entrepreneurship on the financial performance of subsidiaries in Colombian business groups under the moderating effect of the environmental dynamism, because the relationship between corporate entrepreneurship and financial performance in emerging economies must differ from developed economies. Using a cross-sectional structural equation modeling analysis, this study assessed the impact of entrepreneurial orientation and corporate venturing on the firm financial performance of 87 subsidiaries of Colombian business groups at different levels of environmental dynamism. This study also confirms that the relationship between corporate entrepreneurship and performance is context-dependent and that entrepreneurial orientation has a strong and positive causal relationship with corporate venturing. Additionally, subsidiaries of Colombian business groups increase their financial performance when also does the entrepreneurial orientation, and decrease financial performance when so does corporate venturing. Furthermore, the results show that environmental dynamism does not have a moderating effect on the relationship between corporate entrepreneurship of subsidiaries in Colombian business groups and their performance. This paper would contribute to important areas in Latin America business, where such studies are scarce.

Keywords: Corporate entrepreneurship, Entrepreneurial orientation, Corporate venturing, Environmental dynamism, Business group, SmartPLS, Emerging economies, Emerging market firms, Colombia

Introduction

Nowadays, corporate entrepreneurship (CE) is an important trend to improve firm financial performance (FP) (Bouchard & Fayolle, 2017; Ferreira, Fernandes, & Peris-Ortiz, 2018; Ireland, Covin, & Kuratko, 2009a; Siota & Prats, 2020). Previous studies have shown that iconic companies such as Google, 3M, Siemens, IBM, Intel, Motorola, and Microsoft apply CE strategies (Covin & Miles, 2007; Finkle, 2012; Fry, 1987; Schaeffer, 2015). This term refers to the entrepreneurial behavior of established companies (Kuratko, 2017), while corporate venturing (CV) and entrepreneurial orientation (EO) are domains of CE (Kuratko, 2017). CV refers to company efforts that lead to the creation of companies within the organization (Kuratko & Audretsch, 2013), and EO reflects the processes that key decision-makers follow to define strategies for achieving organizational purposes, maintaining the vision and creating competitive advantages for the company (Rauch, Wiklund, Lumpkin, & Frese, 2009). Furthermore, environmental dynamism (ED) refers to the speed and the way in which the business environment changes (Lumpkin & Dess, 2001).

Prior literature has revealed a positive causal relationship between CE and FP in developed economies (Bierwerth, Schwens, Isidor, & Kabst, 2015; Morris, Kuratko, & Covin, 2011; Wiklund & Shepherd, 2003), and moderating effects of ED over the relationship between the above (Ambad & Wahab, 2016; Lumpkin & Dess, 2001). Besides, many studies have approached the effects of CE on FP in developed economies (Narayanan, Yang, & Zahra, 2009; Wiklund, 1999). However, little research to date has examined those effects in emerging economies (De Villiers-Scheepers, 2012; Demirkan, Yang, & Jiang, 2019), leaving a gap in the literature about CE in Latin America, where it is a recent trend (Kantis & Angelelli, 2020; Prats & Siota, 2018). This comes up with the question of whether these causal relations are similar for emerging economies, because their conditions are very different (Kelley, Singer, & Herrington, 2016).

Emerging economies have shortcomings such as a weak legal environment, a lack of financial resources, and a shortage of skilled labor, which hinders the development of companies (Zhou, Gao, & Zhao, 2017). Furthermore, the entrepreneurship ecosystems of developed and emerging economies have marked differences in many contexts: institutional environment, government support, technological advances, cultural influences, socioeconomic conditions, characteristics, motivations, and ambitions of entrepreneurs (Carayannis, Ferreira, Ferreira, & Peris-Ortiz, 2016; Farinha, Ferreira, & Nunes, 2018; Ferreira, Carayannis, Campbell, Farinha, Smith, & Bagchi-Sen, 2018; Kelley et al., 2016). Moreover, questions like how these differences affect CE activities in emerging economies remain unanswered (Demirkan et al., 2019).

The motivations for this research arise from several studies. Equipo UDD Ventures (2020) argued that CE creates opportunities in employment, technological advances, value creation, and cultural transformation for Latin American ecosystems, entrepreneurs, governments, economies, and society. Second, CE requires more research to assess how moderating factors affect its results (Kuratko, 2017; Narayanan et al., 2009; Rauch et al., 2009). Third, in the last 7 years, corporate ventures have quadrupled worldwide, where the biggest companies have a higher adoption level than the smaller ones (Siota & Prats, 2020); Latin America, for example, has an average adoption level of 16%, far from 75% of Fortune 100 list (Knox, 2019; Siota & Prats, 2020). Likewise, 70% of corporations are investing in CE (Prats & Siota, 2018). Moreover, this study is the first of its kind to address these questions in the Colombian context.

Thus, the purpose of this study was to assess the impact of CE on FP of subsidiaries of Colombian business groups (SCBG) under the moderating effect of ED. To explore that, this work applied a mail survey with adapted scales, used in past researches, to employees of SCBG. Furthermore, it used structural equation modeling (SEM) to assess the relationships among the model variables. Finally, the present article studied the literature review and development of hypotheses based on a behavioral model of the relationship between CE and FP of SCBG, and the moderating effect of ED on this relationship. It also took into account the research method, results, discussion, managerial implications, limitations, future research directions, and, lastly, conclusions.

Literature review

Corporate entrepreneurship

This is a recent term that has attracted the attention of academics since the 1970s (Kuratko, 2017). The proliferation of terms to refer to CE dispersed the attention of researchers and made it difficult to build and strengthen their theory (Ferreira, 2010; Hind & Steyn, 2015; Sharma & Chrisman, 1999).

CE encompasses two types of phenomena and the processes surrounding them (a) the birth of new business within an existing organization, i.e., internal innovation or venturing, and (b) the transformation of organizations through the renewal of the key ideas on which they are built, i.e., strategic renewal. (Guth & Ginsberg, 1990, p. 5)

In the 1970s, CE was a strategy for managing large organizations in dynamic markets, and the research focused on the creation of teams to cope entrepreneurial activities that generated growth in organizations (Kuratko, 2017). In the 1980s, CE, understood as an innovation method, was prolific in research; conservative and entrepreneurial innovation models were compared, and CE was seen as an opportunity generator of large companies. Success factors for innovation were analyzed (Kuratko, 2017). In this decade, the first CE book was written (Pinchot, 1986) and the first investigations of the relationship between CE and FP began (Miller, Wilson, & Adams, 1988).

The 1990s catapulted the research of CE. The principal subjects were the relationship between CE, FP, and ED (Vozikis, Bruton, Prasad, & Merikas, 1999): CE as an innovation mechanism to update organizations (Covin & Miles, 1999; Ferreira, 2001), the relationship between CE and the firm policy (Barringer & Bluedorn, 1999), the research of CE types (Covin & Miles, 1999), and CE as a strategy to develop skills and knowledge (Floyd & Wooldridge, 1999). "Knowledge is a fundamental building block of entrepreneurial ventures" (Carayannis & Provan, 2018, p. 188). Starting in the twenty-first century, strategic entrepreneurship emerged as the third domain of CE; this was studied from the culture perspective (Garvin & Levesque, 2006) and the Corporate Entrepreneurship Assessment Instrument (CEAI) emerged as a tool for measuring CE (Kuratko, Hornsby, & Covin, 2014).

However, several perspectives need research to understand the relationship between CE and FP. Some of them are the influence of mediating and moderating variables, the differences conditioned by characteristics of the natural business environment of each region and the magnitude of the relationship between CE and performance (Knight, 1997; Rauch et al., 2009; Thomas & Mueller, 2000; Wiklund & Shepherd, 2005). "There

remains a greater need for further research about CE in organizational settings” (Kuratko, 2017, p. 442).

Behavioral model of CE and FP

Covin and Slevin (1991) argued that entrepreneurship effectiveness is a phenomenon that depends on organizational routines and individual behaviors; this, having in mind that behavioral manifestations of entrepreneurship may be a measure of the firm’s entrepreneurial level. Thus, an organization assumes an entrepreneurial posture if it visualizes the possibility of high returns. Moreover, it will develop high-risk projects, showing aggressive behavior in the search for opportunities, being proactive, and taking the initiative in front of opportunities before its competitors (Miller, 2011). Recently, the literature shows that the research regarding the relationship between CE and FP is in the exploratory stage (Alam, Nasir, & Rehman, 2020).

The overarching model of Fig. 1 is represented by EO and CV as the independent variables, while FP—reflected in return on equity (ROE)—and revenue growth (RG) are the dependent ones (Kreiser & Davis, 2010; Zahra, 1993).

Entrepreneurial orientation

A firm with entrepreneurially oriented stances has innovative, proactive, risk-taking, autonomous, and competitive behaviors (Anderson, Kreiser, Kuratko, Hornsby, & Eshima, 2015; Lumpkin & Dess, 2001; Miller, 2011). Furthermore, entrepreneurial firms are bold to introduce products and take part in high-risk projects with high-return possibilities, which require extensive amounts of resources to undertake in uncertain environments (De Clercq, Dimov, & Thongpapanl, 2013; Miller, 1983). Additionally, the literature shows a positive relationship between EO and company performance (Ambad & Wahab, 2016; Anderson et al., 2015; Covin & Slevin, 1991; Karacaoglu,

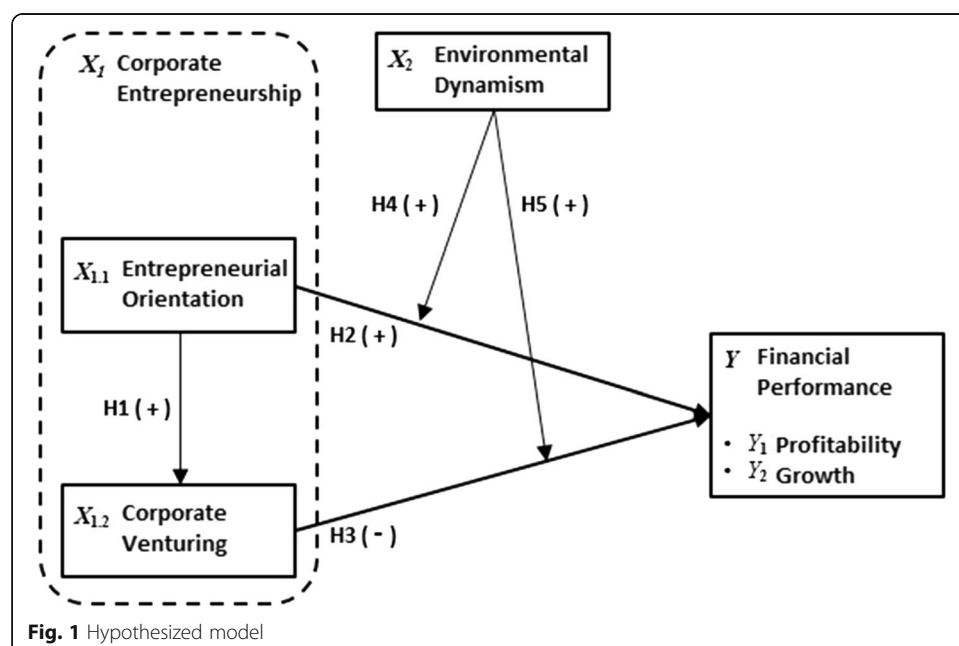

Bayrakdaroglu, & San, 2012; Kaya, 2006; Lee, Zhuang, Joo, & Jun, 2019; Mohamad, Ramayah, Puspowarsito, Natalisa, & Saerang, 2011; Wiklund, 1999). However, how strong is the relationship between EO and FP remains an open question (Rauch et al., 2009).

Although some authors declared that in developed countries the entrepreneurially oriented behaviors of a company have a positive relationship with its profitability and growth (Covin, Green, & Slevin, 2006; Ireland et al., 2009; Lumpkin & Dess, 1996), there are insufficient data to prove that this is true in emerging economies, specifically in SCBG. For these reasons, this paper proposes the next hypothesis.

Hypothesis 1: EO has a positive relation with CV in SCBG.

Hypothesis 2: EO has a positive relation with the FP of SCBG.

Corporate venturing

The fundamental idea of CV is that a large firm, with the ambition to achieve financial objectives and strategies, cooperates with a small and autonomous unit to develop a business model (Hill, Maula, Birkinshaw, & Murray, 2009; Sharma & Chrisman, 1999). CV has a relation with the creation of new business units, product innovation (PI), the acquisition and sponsorship of new companies, and the degree to which companies strengthen in terms of the technologies they use (Zahra, 1993).

Although prior studies have related CV to the firm's growth and profitability (Ambad & Wahab, 2016; Antoncic & Hisrich, 2001), and some scholars have shown in developed countries that CV initiatives generate economic benefits for the company and improve its market performance (e.g., Antoncic & Hisrich, 2001; Garud, Jain, & Kumaraswamy, 2002; Zahra, 1996), there is not enough data to prove that this is true in emerging economies, specifically in SCBG. On the other hand, CV projects require great resources and organizational capabilities (Tang, Tang, Marino, Zhang, & Li, 2008; Wiklund, 1999); therefore, a company without enough resources and capabilities runs a high risk of failure if it tries to carry out CV projects that are out of its reach (Tang et al., 2008), which can negatively affect the company's performance. Additionally, many companies that use CV activities never achieve or support positive overall outcomes through their venturing efforts (Covin & Miles, 2007). The above explained leads to the next hypothesis.

Hypothesis 3: CV has a negative relation with the FP of SCBG.

Environmental dynamism

Previous scholars have established that ED is related to the business environment in an unpredictable form of change (Duncan, 1972; Lumpkin & Dess, 2001; Tosi, Aldag, & Storey, 1973) and to the uncertainty that diminishes the manager's ability to predict events and their impact on the organization (Lumpkin & Dess, 2001). Furthermore, ED is related to how quickly products become obsolete in an industry and how fast must be updated the technology used in an industry, how predictable are the reactions of competitors, and how predictable are changes in tastes and consumer demands (Zahra, 1993).

The more dynamic and hostile environment, the higher the innovation is needed (Miller et al., 1988; Miller & Friesen, 1982). Several studies in developed countries have

emphasized ED has a moderating effect between CE and FP (Tajeddini & Mueller, 2018; Zahra & Covin, 1995). Wiklund and Shepherd (2005); Zhang (2009); Frank, Kessler, and Fink (2010); and Kim and Kim (2016) found no evidence of the moderating role of ED in the EO-FP relationship. Additionally, Zahra (1993) realized that the moderating effect of ED on the EO-FP relationship in static and impoverished environments is negative. Then, considering that researchers have not determined the effect of ED on the relationship between SCBG's CE and its performance to this date, this work proposes the next two additional hypotheses.

Hypothesis 4: The relationship between EO of SCBG and FP is moderated by ED. SCBG performance increases with EO but at a faster rate for those in dynamic environments.

Hypothesis 5: The relationship between CV of SCBG and FP is moderated by ED. SCBG performance increases with CV but at a faster rate for those in dynamic environments.

Business groups in emerging economies

A business group aims to take advantage of the market inefficiencies or the lack of regulatory authorities in emerging economies through the diversification gained with a network of firms. Scholars state that “a business group is a collection of legally independent firms that are linked by multiple ties, including ownership, economical means (such as inter-firm transactions), and social relations (family, kinship, friendship), through which they coordinate to achieve mutual objectives” (Khanna & Rivkin, 2001; Yiu, Lu, Bruton, & Hoskisson, 2007, p. 1553). Furthermore, considering that “business groups are significant engines of growth” (Stramaglia, 2010, p. 209), and that no research has examined CE in business groups in emerging economies (Wilches & Rodríguez, 2016), the findings presented here provide insights to understand CE in this context.

Methods

This was a quantitative and cross-sectional research. The methodological design included two steps: first, a stage of adaptation and validation of scales to the context, to measure the exogenous variables of the model, and second, the estimation of the relations between the exogenous variables with the FP of SCBG. This, to test the five hypotheses assessed, the relationships between CE and FP, the effect of the moderating variable (ED) on the relationships between EO and CV with FP, and the interaction terms (IT), ED-EO and ED-CV. The target population was 857 from the biggest SCBG. The data collection procedure was carried out through a mail survey, for which the sampling frame was master's students and alumni of two private universities in Bogotá. This research worked with 87 SCBG, with the data of 202 employees selected by homogeneous convenience sampling from 700 survey responses (Jager, Putnick, & Bornstein, 2017). Table 1 shows respondent characteristics.

The 7-point Likert-type semantic differential scales to measure exogenous variables—such as EO, CV, and ED—were taken from seminal literature and adapted to the Colombian context (Covin & Slevin, 1989; Lumpkin & Dess, 2001; Miller & Friesen, 1982; Zahra, 1993) and also were the financial data—to measure the endogenous

Table 1 Respondent characteristics

Respondent profile	Number	Percentage
Ages		
Less than 25	13	6%
Between 25 and 30	62	31%
Between 30 and 35	40	20%
Between 35 and 40	37	18%
Between 40 and 45	27	13%
Between 45 and 50	12	6%
Between 50 and 55	6	3%
Between 55 and 60	3	1%
More than 60	2	1%
Gender		
	202	
Female	8	4%
Male	194	96%
Study level		
	202	
Specialization	100	50%
Professional	56	28%
Master's degree	40	20%
PhD candidate	2	1%
Doctor	2	1%
Other	2	1%
Job title		
	202	
Professional analyst	79	39%
Director/coordinator/area manager	55	27%
Project manager	22	11%
Department manager	9	4%
Vice-president	3	1%
Other	34	17%

Source: computed by the author

variable were ROE—and RG, using Eqs. (1) and (2) (Kreiser & Davis, 2010). These were drawn from the Emerging Markets Information Service (EMIS) database, recognized worldwide as the leading provider of data for emerging economies. Considering that each company belongs to a specific industry, it was necessary to standardize these data using Eqs. (3) and (4) (Zahra, 1993).

$$ROE = \text{net income} / \text{total equity} \tag{1}$$

$$RG = (\text{current year's revenue} - \text{last year's revenue}) / (\text{last year's revenue}) \tag{2}$$

$$ROEN_i = (ROE_{Ci} - AROE_s) / (\sigma (ROE_s)) \tag{3}$$

$$RGN_i = (RG_{Ci} - RG_s) / (\sigma (RG_s)) \tag{4}$$

where:

ROEN_i Normalized ROE of the company *i*

ROE_{Ci} ROE of the company *i*

AROE_s Average ROE of the sector

ROE_s ROE of the sector

σ Standard deviation

RGN_{*i*} Normalized RG of the company *i*

RG_{*Ci*} Net RG of the company *i*

ARG_s Average RG of the sector

RG_s Net RG of the sector

This study applied Partial Least Squares-Structural Equation Modeling (PLS-SEM) using SmartPLS 3 software; this one combines factorial and regression analysis, allowing simultaneous examination of relationships between observable and latent variables and measurement valuation, as well as between latent variables and structural model assessment. PLS-SEM aims to maximize the explained variance (R^2) of the latent endogenous variables of the SEM model. Considering the practical rules of R^2 analysis, the results of 0.75, 0.50, or 0.25 for endogenous constructs are substantial, moderate, or weak. According to Falk and Miller (1992), the minimum value for R^2 should be 0.10. PLS-SEM has advantages when sample sizes are small and the model has many indicators and relationships, like in this research (Hair, Hult, Ringle, & Sarstedt, 2017; Hair, Risher, Sarstedt, & Ringle, 2018). Besides, PLS-SEM is better to evaluate convergence (Gefen, Rigdon, & Straub, 2011); furthermore, it has an outstanding ability to explain and predict endogenous latent variables, proceeding from the model estimates on the coefficient of determination R^2 (Ringle, Sarstedt, & Straub, 2012).

The sample size recommendation in PLS-SEM for a statistical power of 80% is a coefficient of determination (R^2) of 0.2, a significance level of 5% and a model complexity level of three is 75 firms (Cohen, 1992; Hair et al., 2017; Marcoulides & Saunders, 2006). On the other hand, according to the “10-times rule” method, the minimum sample size must be 10 times the maximum number of inner or outer links pointing to any of the latent variables of the model (Kock & Hadaya, 2018). There must be considered that, in the model used in this research, the maximum number of links pointing at the dependent variable is 3, which multiplied by 10 equals 30. Despite that, the sample size was 87 firms. To test the validity and reliability of the structural and measurement models, the techniques listed in Table 2 were applied.

Results

This research aimed to assess the relationship between EO and CV, the impact of EO and CV on the FP of SCBG under the moderating effect of ED, and the moderating effect of ED on the relationship of CE and FP of SCBG. Table 3 provides descriptive statistics and the correlation matrix for all variables. The correlation between the independent variables was relatively high. Additionally, ED has a positive correlation with the variables technological entrepreneurship (TE) and expansion and growth (EG); and RG has a negative correlation with PI.

Measurement instrument validation

The first thing to do is to examine the measurement model, which includes internal consistency and convergent and discriminant validity; the objective is to

Table 2 Measurement and structural model validation

Model validity and reliability		Heuristics/techniques
1	Content validity	<ul style="list-style-type: none"> • Literature review • Judges
2	Face validity	<ul style="list-style-type: none"> • Pilot test • Judges
Measurement model valuation		
1	Convergent validity	<ul style="list-style-type: none"> • Composite reliability • Average variance extracted (AVE) • Cronbach's alpha
2	Internal consistency	<ul style="list-style-type: none"> • Indicator reliability
3	Discriminant validity	<ul style="list-style-type: none"> • Cross loads • Fornell and Larcker (1981) • Heterotrait-monotrait (HTMT)
Structural model valuation		
1	Collinearity analysis	
2	Size and significance of path coefficients	
3	Coefficients of determination	R ²
4	Predictive relevance	Q ²

Note. Adapted from (Hair et al., 2017)

ensure that the measures used in the analysis are reliable and valid. Then, the structural model can be examined. The analysis demonstrates that the research model has internal consistency and convergent and discriminant validity, as seen in the measurement model valuation in Table 4, the structural model valuation in Table 7, the cross-loading criterion and the confidence intervals bias-corrected

Table 3 Descriptive statistics and correlations

	Mean	S.D. ^b	ED	IN	PR	RT	AU	AG	BC	PI	TE	EG	ROE	RG
ED _a	3.65	1.26	1											
IN	4.21	1.39	.194	1										
PR	4.67	1.46	.104	.605**	1									
RT	3.98	1.47	.168	.561**	.604**	1								
AU	4.84	1.16	.020	.429**	.556**	.625**	1							
AG	4.45	1.20	.007	.384**	.417**	.461**	.394**	1						
BC	4.51	1.32	.052	.631**	.570**	.571**	.474**	.600**	1					
PI	4.65	1.27	.153	.655**	.549**	.590**	.412**	.404**	.734**	1				
TE	3.97	1.50	.244*	.514**	.541**	.572**	.445**	.253*	.303**	.519**	1			
EG	4.00	1.49	.288**	.624**	.521**	.556**	.395**	.279**	.433**	.574**	.609**	1		
ROE	—	1.16	—	.191	.048	—	.119	—	—	—	.141	—	—	1
	0.09			.047		.107		.075	.046		.140	.143		
RG	0.00	1.05	—	.208	—	—	.021	.144	—	—	.021	.029	.169	1
				.089	.028				.127	.092	.253*			

Source: computed by the author using SPSS. n = 87

*The correlation is significant at the 0.05 level (bilateral)

**The correlation is significant at the 0.01 level (bilateral)

^aThe first column includes principal latent variables that are used in this study: environmental dynamism (ED), innovativeness (IN), proactiveness (PR), risk-taking (RT), autonomy (AU), aggressiveness (AG), business creation (BC), product innovation (PI), technological entrepreneurship (TE), expansion and growth (EG), return on equity (ROE), and revenue growth (RG)

^bStandard deviation

Table 4 Measurement model valuation

Latent variable	Indicators	Convergent validity			Internal consistency reliability		Discriminant validity
		Loadings	Indicator reliability	AVE ^c	Composite reliability	Cronbach's alpha	
		>0.70	>0.50	>0.50	0.60–0.90	0.60–0.90	
AG ^a	AG1 ^b	0.939	0.882	0.7838	0.8784	0.7381	Yes
	AG2	0.828	0.686				
RT	RT1	0.900	0.810	0.8111	0.9280	0.8836	Yes
	RT2	0.913	0.834				
	RT3	0.889	0.790				
IN	IN1a	0.857	0.734	0.7055	0.9052	0.8595	Yes
	IN1b	0.877	0.769				
	IN2a	0.871	0.759				
	IN2b	0.749	0.561				
AU	AU1	0.843	0.711	0.6505	0.8814	0.8206	Yes
	AU2	0.808	0.653				
	AU4	0.757	0.573				
	AU6	0.816	0.666				
PR	PR1a	0.890	0.792	0.7894	0.9374	0.9107	Yes
	PR1b	0.923	0.852				
	PR1c	0.847	0.717				
	PR2a	0.891	0.794				
BC	BC2	0.811	0.658	0.6334	0.8959	0.8543	Yes
	BC3	0.818	0.669				
	BC4	0.702	0.493				
	BC5	0.829	0.687				
	BC6	0.812	0.659				
TE	TE3	0.773	0.598	0.7024	0.8243	0.5875	No
	TE5	0.898	0.806				
EG	EG1	0.853	0.728	0.6806	0.8949	0.8434	Yes
	EG2	0.830	0.689				
	EG3	0.830	0.689				
	EG5	0.785	0.616				
PI	PI1	0.722	0.521	0.6845	0.8962	0.8442	Yes
	PI2	0.850	0.723				
	PI3	0.879	0.773				
	PI5	0.849	0.721				
ED	ED2	0.834	0.696	0.6179	0.8288	0.6971	Yes
	ED3	0.761	0.579				
	ED4	0.762	0.581				
FP	RGN	0.746	0.557	0.5843	0.7375	0.2890	Yes
	ROEN	0.782	0.612				

Source: computed by the author using SmartPLS 3. Adapted from Hair et al. (2017)

^aThe first column includes principal latent variables that are used in this study: aggressiveness (AG), risk-taking (RT), innovativeness (IN), autonomy (AU), proactiveness (PR), business creation (BC), technological entrepreneurship (TE), expansion and growth (EG), product innovation (PI), environmental dynamism (ED), financial performance (FP), revenue growth normalized (RGN), and return on equity normalized (ROEN)

^bThe names of the items correspond to the way they are labeled on their measurement scales

^cAVE average variance extracted

^dHTMT heterotrait-monotrait

of HTMT that support the discriminant validity of the model (Hair et al., 2017; Henseler, Ringle, & Sarstedt, 2015).

Assessing reflective measurement model

The indicator loadings above 0.708 show that the construct explains over 50% of the indicator’s variance, providing acceptable item reliability (Hair et al., 2018). The composite reliability between 0.70 and 0.90 shows that the model has “satisfactory to good” internal consistency reliability (Hair et al., 2018). To test convergent validity, AVE values were calculated, which were well above 0.5. Therefore, all reflective constructs present high levels in terms of convergent validity (Hair et al., 2018).

To assess discriminant validity, “which is the extent to which a construct is empirically distinct from other constructs in the structural model” (Hair et al., 2018, p. 1), the Fornell and Larcker (1981) criterion was calculated. If the square root of the AVE of each reflective construct (shown in the diagonal on Table 5) is higher than the correlations possessed by the rest of the constructs in the model, then constructs have discriminant validity. These results show that all the constructs are valid measures and unique concepts.

Although in research the Fornell and Larcker (1981) and cross-load criteria are very used, they are not reliable to measure discriminant validity with absolute certainty (Hair et al., 2017). Thus, the HTMT criterion proposed by Henseler et al. (2015) must be a better one. HTMT is the ratio of the correlations between traits and the correlations among traits; it is also an estimation of what the actual relationship would be between two constructs if they were perfectly measured; in other words, if they were utterly

Table 5 Discriminant validity—Fornell-Larcker criterion

	AU	AG	BC	ED	EG	FP	IN	PR	PI	RT	TE
AU ^a	0.8065										
AG	0.4286	0.8853									
BC	0.4706	0.6281	0.7959								
ED	0.0171	0.0287	0.0564	0.7861							
EG	0.4025	0.3236	0.4381	0.2773	0.8250						
FP	0.1718	–	–	–	–	0.7644					
		0.1143	0.0893	0.2635	0.0788						
IN	0.4268	0.4137	0.6334	0.1916	0.6242	–	0.8399				
						0.0895					
PR	0.5569	0.4367	0.5773	0.0968	0.5208	0.0155	0.6068	0.8885			
PI	0.4067	0.4246	0.7385	0.1700	0.5931	–	0.6593	0.5557	0.8273		
						0.2634					
RT	0.6279	0.4828	0.5729	0.1700	0.5656	–	0.5605	0.6056	0.5886	0.9006	
						0.0609					
TE	0.4836	0.3017	0.3411	0.2549	0.6206	–	0.5381	0.5729	0.5437	0.5872	0.8381
						0.0819					

Source: computed by the author using SmartPLS 3

^aThe first column includes principal latent variables that are used in this study: autonomy (AU), aggressiveness (AG), business creation (BC), environmental dynamism (ED), expansion and growth (EG), financial performance (FP), innovativeness (IN), proactiveness (PR), product innovation (PI), risk-taking (RT), and technological entrepreneurship (TE)

^bDiagonals (bold) represent the square root of the AVE, while other entries represent the correlations

Table 6 Discriminant validity—HTMT ratio

	AU	AG	BC	ED	EG	FP	IN	PR	PI	RT	TE
AU											
AG	0.4952										
BC	0.5550	0.7567									
ED	0.1605	0.1234	0.1451								
EG	0.4768	0.3565	0.5064	0.3929							
FP	0.3690	0.2962	0.2515	0.5717	0.2482						
IN	0.5023	0.4824	0.7369	0.2671	0.7252	0.2622					
PR	0.6346	0.5081	0.6498	0.1687	0.5925	0.1886	0.6864				
PI	0.4834	0.5079	0.8675^a	0.2594	0.6933	0.5255	0.7780	0.6315			
RT	0.7329	0.5712	0.6587	0.2323	0.6461	0.1923	0.6437	0.6715	0.6758		
TE	0.6733	0.3922	0.4394	0.3876	0.8683	0.3140	0.7370	0.7445	0.7448	0.7971	

Source: computed by the author using SmartPLS 3. The first column includes principal latent variables that are used in this study: autonomy (AU), aggressiveness (AG), business creation (BC), environmental dynamism (ED), expansion and growth (EG), financial performance (FP), innovativeness (IN), proactiveness (PR), product innovation (PI), risk-taking (RT), and technological entrepreneurship (TE)

^aHTMT values > 0.85 are in boldface

reliable (Hair et al., 2017). Table 6 presents the HTMT ratio values among the exogenous model constructs. Keeping in mind that Henseler et al. (2015) recommended a maximum threshold of 0.85 for HTMT results, and considering that, out of the 55 findings from Table 6, only two present values are exceeding 0.85, there is enough evidence to suggest that the model has discriminant validity.

The “bootstrapping” technique was applied to test if HTMT is different from 1, which consists of randomly taking a series of sub-samples, replacing the original data with the one estimated by the model and ultimately determining a confidence interval from the “bootstrap”. This confidence interval is where the actual HTMT value lies, assuming a confidence level of 95%; if the confidence interval does not contain the value 1, then the compared constructs are empirically distinct and, therefore, show evidence of discriminant validity.

Assessing structural model

The research model displays no collinearity issues among predictor constructs, because variance inflation factor (VIF) values are below the threshold of 5, as shown in the structural model valuation in Table 7 (Hair et al., 2017).

Considering that collinearity is not a problem, the next step is to examine the R^2 value of the endogenous construct. PLS-SEM aims to maximize the explained variance

Table 7 Structural model valuation

	Path coefficients	t value ^b	95% confidence intervals	Significant	VIF ^c
EO → FP ^a	0.3699	2.087**	[− 0.0015, 0.6873]	No	3.0350
CV → FP	− 0.4232	2.454**	[− 0.7454, − 0.0643]	Yes	3.1189
ED → FP	− 0.2242	1.961**	[− 0.4009, 0.1838]	No	1.0518

Source: computed by the author using SmartPLS 3

^aEntrepreneurial orientation (EO), corporate venturing (CV), environmental dynamism (ED), and financial performance (FP)

^b* $p < 0.10$, ** $p < 0.05$, *** $p < 0.01$. Two-tailed test t value = 1.96

^cVIF variance inflation factor. VIF threshold value = 5

(R^2) of the latent endogenous variables of the model. Considering the practical rules of R^2 -analysis, the results of 0.75, 0.50, or 0.25 for endogenous constructs are substantial, moderate, or weak (Hair et al., 2018; Henseler, Ringle, & Sinkovics, 2009). Then, the R^2 of FP is weak (0.1277); however, according to Falk and Miller (1992), the minimum value for R^2 should be 0.10.

To assess the PLS path model’s predictive accuracy, the Q^2 value were calculated (Geisser, 1974; Stone, 1974). As suggested by Hair et al. (2017), a model has predictive relevance if Q^2 is greater than 0; then, the results of Q^2 demonstrate that all exogenous variables have satisfactory predictive relevance, as shown in the PLS path model’s predictive accuracy in Table 8 (Hair et al., 2017; Henseler et al., 2009).

Relation between EO and CV of SCBG

As shown in the hypothesis testing in Table 9 and the SEM in Fig. 2, EO and CV of SCBG have a strong positive causal relation ($\beta = .822, p = .000$), which provides support for hypothesis 1. This keeps in line with earlier research that showed that EO reflects behaviors of the key decision-makers in front of the business context (Barringer & Bluedorn, 1999; Covin & Slevin, 1989), and that CV represents the manifestations of EO, such as innovative processes and products and business units creation (Sharma & Chrisman, 1999).

Effect of EO on the FP of SCBG under the moderating effect of ED

As shown in the hypothesis testing in Table 9 and the SEM in Fig. 2, although EO is positively related to firm performance ($\beta = .369, p = .037$), this relationship

Table 8 PLS path model’s predictive accuracy

Exogenous construct	SSO ^b	SSE ^c	Q ² (=1-SSE/SSO) ^d
AU ^a	3,480,000	2,226,190	0.3603
AG	1,740,000	1,265,015	0.2730
CV	1,305,000	1,305,000	
BC	4,350,000	2,610,852	0.3998
EO	1,479,000	1,479,000	
ED	2,610,000	2,610,000	
EG	3,480,000	2,083,007	0.4014
IN	3,480,000	2,064,864	0.4066
PR	3,480,000	1,598,949	0.5405
PI	3,480,000	1,628,330	0.5321
RT	2,610,000	1,207,631	0.5373
TE	1,740,000	1,217,996	0.3000

Source: computed by the author using Smart PLS 3

^aThe first column includes principal latent variables that are used in this study: autonomy (AU), aggressiveness (AG), corporate venturing (CV), business creation (BC), entrepreneurial orientation (EO), environmental dynamism (ED), expansion and growth (EG), innovativeness (IN), proactiveness (PR), product innovation (PI), risk-taking (RT), and technological entrepreneurship (TE)

^bSSO sum of the squared observations

^cSSE sum of the squared prediction errors

^dQ²>0 exogenous constructs have predictive relevance for endogenous ones

Table 9 Hypothesis testing

Hypothesis	Relation	Standard Beta	t value	f^2	q^2	95% confidence intervals	Supported
H1	EO -----> CV	0.8222***	2.471	2.0670	0.038	[0.739, 0.871]	Yes
H2	EO -----> FP	0.3699**	2.048	0.0630	- 0.363	[- 0.029, 0.686]	No
H3	CV -----> (-) FP	- 0.4232**	2.440	0.0050	0.055	[- 0.757, - 0.073]	Yes
H4	IT(ED-EO) --> FP	- 0.0185	0.164	0.0005	0.010	[- 0.221, 0.210]	No
H5	IT(ED-CV) --> FP	0.0558	0.522	0.0029	- 0.007	[- 0.142, 0.288]	No

Source: computed by the author using Smart PLS 3. Two-tailed test t value = 1.96. f^2 range values .02 small, .15 medium, .35 large. q^2 range values .02 small, .15 medium, .35 large
 ** $p < 0.05$, *** $p < 0.01$

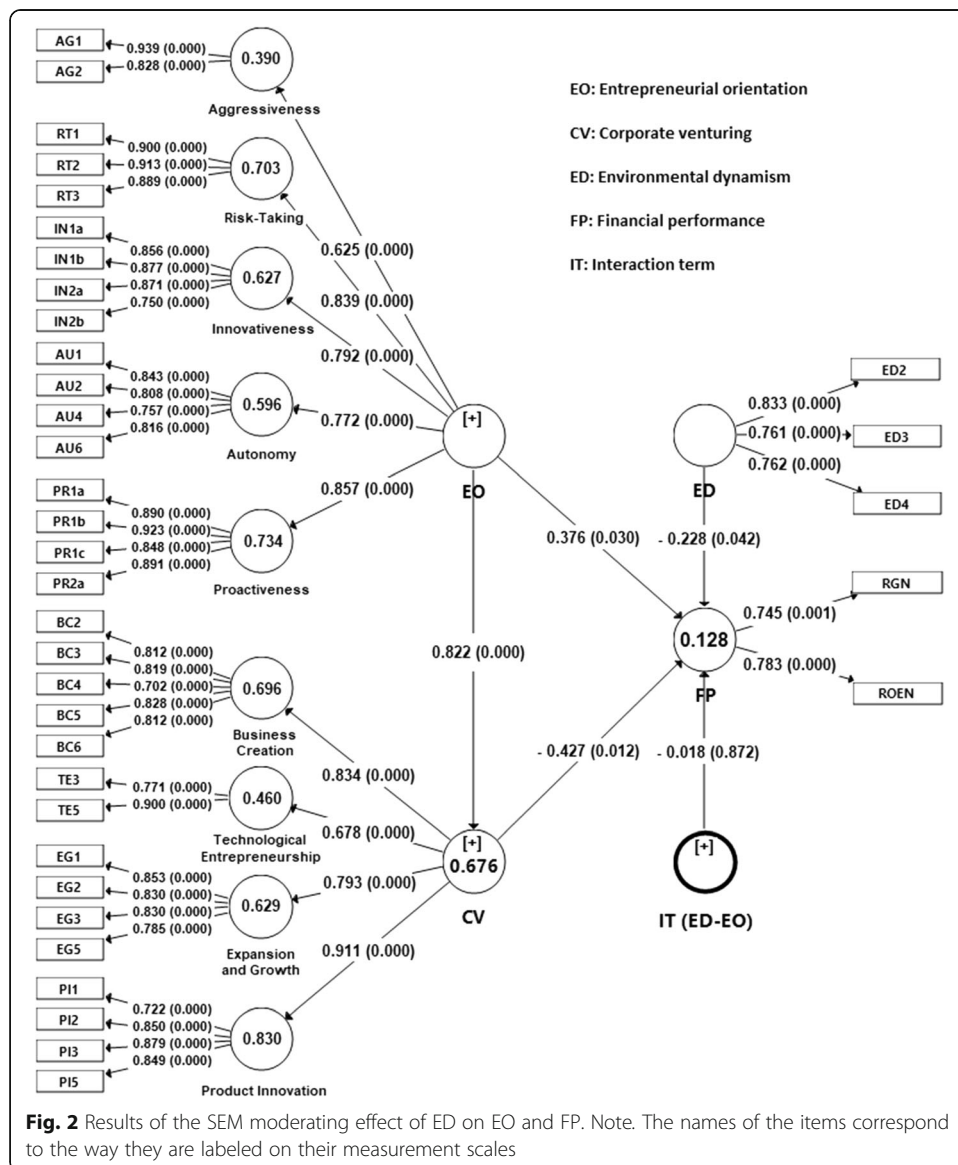

could not be proven because the confidence interval contains 0 $[-0.029, 0.686]$. Thus, hypothesis 2 did not find support. Although this result differs from those that proved the positive impact of EO on firm performance (Covin et al., 2006; Ireland et al., 2009; Tajeddini & Mueller, 2018), it was coherent with others who could not prove this relationship either (Covin, Slevin, & Schultz, 1994; George, Wood, & Khan, 2001).

Effect of CV on the FP of SCBG under the moderating effect of ED

As shown in the hypothesis testing in Table 9 and the SEM in Fig. 2, CV and FP of SCBG have a strong negative causal relation ($\beta = -0.423, p = .014$), which provides support for hypothesis 3. This result coincides with Covin and Miles (2007), who stated that many companies that apply CV strategies never achieve nor sustain positive results through these entrepreneurial projects. Furthermore, this result is consistent with Zahra and Covin (1995), who expressed that many of the financial and market benefits take time to materialize; therefore, these benefits may not be clear (Narayanan et al., 2009).

Moderation effect of ED between the relation of EO and FP of SCBG

As shown in the hypothesis testing in Table 9 and the SEM in Fig. 2, the IT, ED-EO, is not related to the firm performance of SCBG ($\beta = -0.018, p = .867$). Thus, hypothesis 4 did not find support. This result is consistent with Kim and Kim (2016), whose “[...] results showed that ED had no significant effect on the EO–FP relationship ($\beta = 0.206, n.s.$)” (p. 7). It is also consistent with Zhang (2009), who found out that ED does not have a moderating effect on the relationship between EO of 143 subsidiaries of multinationals in China and their performance. On the other hand, the results of this research reaffirm those of Frank et al. (2010) and Wiklund and Shepherd (2005), who stated that the moderating effect of ED of the relationship between EO-FP is not significant.

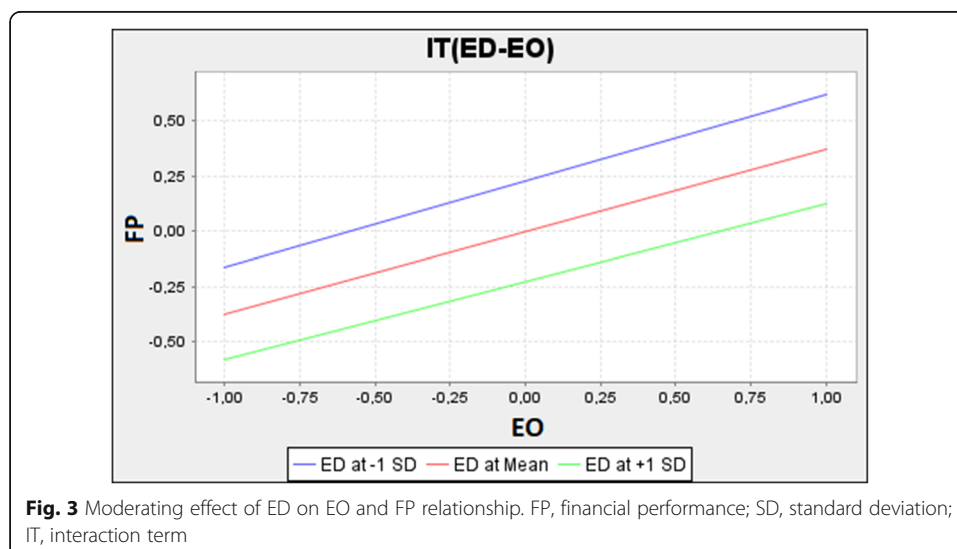

Additionally, the effect size (f^2) of the IT, ED-EO, is marginal ($f^2 = 0.0005$) (Cohen, 1988). Besides, as shown in the moderating effect of ED on EO and FP relationship in Fig. 3, a higher EO raises the FP of SCBG. The results of the model with the moderating variable, ED, and without it (not reported for space limitations) were similar.

Moderation effect of ED between the relation of CV and FP of SCBG

As shown in the hypothesis testing in Table 9 and the SEM in Fig. 5, the IT, ED-CV, is not related to firm performance of SCBG ($\beta = .055$, $p = .610$). Thus, hypothesis 5 did not find support. This result was contrary to Zahra and Covin (1995) and Narayanan et al. (2009), who found the moderating effect of ED over the relationship between CV and FP. Furthermore, the effect size (f^2) of the IT, ED-CV, is marginal ($f^2 = 0.0029$) (Cohen, 1988), as seen in the hypothesis testing in Table 9. Figure 4 shows an opposite relationship between CV and FP of SCBG.

In summary, this research found support for hypotheses 1 and 3. However, it did not find support for hypotheses 2, 4, and 5, as shown in the hypothesis testing in Table 9. Therefore, the structural equation analysis revealed that EO has a strong and positive causal relationship with CV in this SCBG sample, and that CV has a negative impact on the FP of SCBG in the short term. Additionally, it could not be proven whether EO affects the FP of the SCBG, and whether ED moderates the relation between EO and CV with the FP of SCBG. The results of the model with and without the moderating variable, ED, were similar.

Discussion

The primary aim of this paper was to assess the impact of CE in the FP of SCBG under the moderation of ED. To fulfill this overarching goal, the analysis focused on answering five fundamental questions. The first one, “is there a positive causal relationship between EO and CV efforts in SCBG?”. This research revealed that EO has a strong and positive causal relationship to CV in this sample, which concurs with earlier research

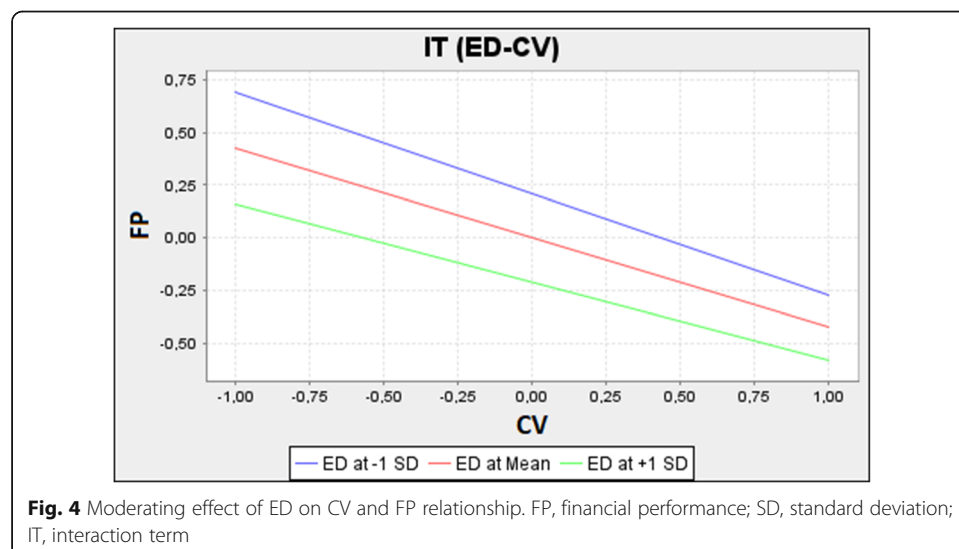

that showed that EO corresponds to behaviors of the key decision-makers in the company in front of the business context (Barringer & Bluedorn, 1999; Covin & Slevin, 1989), and that CV explains the manifestations of EO, such as innovative processes, innovative products and business units creation (Sharma & Chrisman, 1999).

Thus, these results suggest that EO is the driving force of CE and CV projects rise if the firms have a strong EO (Covin & Slevin, 1991; Kuratko, 2017). On the other hand, it suggests that the willingness to be innovative, proactive, competitive, autonomous, and risk-taking oriented in the SCBG has a positive relationship with the development of products and firms consolidation; this is in line with Dess and Lumpkin (2005), who stated that “firms often rely on an EO to enhance their corporate venturing activities” (p. 148). Also, this result not only highlights the importance of encouraging EO and CE strategies within the firm to generate companies based on knowledge and innovation (Campbell & Carayannis, 2016), but also implies to count on enough resources and capabilities within the company as well as a stronger entrepreneurial and innovation ecosystems (Carayannis, Dagnino, Alvarez, & Faraci, 2018), which is coherent with the organizational models for CV activities revealed in Battistini, Hacklin, and Baschera (2013).

The second question, “is there a positive causal relationship between EO and the FP of SCBG?”. Although the results meet significance, and meet algebraic sign criteria, the confidence interval based on the “bootstrap” presents problems that do not allow to support this relationship. Even when this result differs from those that proved the positive impact of EO on firm performance (Covin et al., 2006; Ireland et al., 2009; Tajeddini & Mueller, 2018), this difference could be due to the fact that the last ones did not report confidence intervals. “Reporting of the bootstrapping confidence interval is less common despite their value-added but is likely to increase in the future” (Hair et al., 2017, p. 197). Moreover, this difference could be explained because the Colombian context is very different from the developed countries ones; then, like Rauch et al. (2009) found in their meta-analysis, this suggests that the EO-FP relationship varies depending on the context and contingencies (e.g. firm size, industry, and environment) (Lumpkin & Dess, 2001; Zahra, 1993; Zahra & Covin, 1995). At last, this result is coherent with others that could not prove this relationship either (Covin et al., 1994; George et al., 2001).

Moreover, this result suggests that CE has boundary conditions associated with the context of each country (Demirkan et al., 2019; Liu & Vrontis, 2017; Miller, 2011). There must be considered that the impact of CE in the FP depends on economic drivers, such as gross domestic product, investment-grade sovereign rating, political and regulatory stability, and environmental hostility (Rauch et al., 2009; Sakhdari & Farsi, 2016); then these differences between emerging and developed economies could explain these results. Whereas the dominant reason for wealth generation in emerging economies is the production intensity, based on efficiency and low costs by scale economies, in developed economies the dominant reason for wealth generation is through the creation of unique goods and services with significant innovations (Farinha et al., 2018; Kelley et al., 2016). The developed economies encourage the birth of knowledge-intensive companies and CE because of government support for entrepreneurship, entrepreneurial financing and training in BC.

Third, “is there a negative causal relationship between CV and FP of SCBG?”. The result confirms the hypothesis that CV has a negative impact on the FP of SCBG’s in the

short term (Fig. 4). This result suggests that considering that CV is a recent trend in Latin America (Prats & Siota, 2018; Kantis, 2018; Kantis & Angelelli, 2020), Colombian companies have not yet developed enough resources and organizational capabilities that allow them to impact their innovation systems with CV projects in a way that improves the FP. The first CV approximations in Colombia were Waira Colombia (<https://hispanam.wayra.com/colombia>), since 2012; Ventures EPM (epm.com.co/site), since 2013; and Sura Ventures (groupsura.com), since 2016 (Kantis & Angelelli, 2020).

Furthermore, according to Narayanan et al. (2009), some CV programs have strategic objectives, while others pursue financial goals. Then, these results suggest that the Colombian CV projects could be oriented to strategic benefits like learning and developing skills, international integration of the company's operations, refining response capacity, establishing better technological and management standards, inspiring internal creation of ideas, and incorporating external knowledge (Battistini et al., 2013; Birkinshaw, 1997); these may take time to be reflected in the financial data (Zahra & Covin, 1995). On the other hand, the present results are aligned with Covin and Miles (2007), who stated that many companies that apply CV projects never achieve nor sustain positive results through these projects. Even more, this result is consistent with Zahra and Covin (1995), who stated that many of the financial and market benefits take time to materialize; therefore, these benefits may not be clear (Narayanan et al., 2009).

In the fourth place, "does ED moderate the relationship between EO and the FP of SCBG?". This research could not prove that the impact of EO on performance increases as ED becomes more dynamic. These results are in line with Wiklund and Shepherd (2005); Zhang (2009); Frank et al. (2010); and Kim and Kim (2016) who found no evidence of the moderating role of ED in the EO-FP relationship. Further, although the results are not significant, they suggest that the relationship between EO and FP is the same for different levels of ED (Fig. 3). One explanation could be that ED in the Colombian context is so low that any increase fails to have an impact on the EO-FP relationship. This could be because Colombian economy is driven by efficiency and low production costs, as a result of scale economies (Kelley et al., 2016); then, the speed at which the products and services of Colombian industry become obsolete is very low, as these are products with low added value content, or plain commodities, such as coffee. Additionally, the Colombian condition of an economy based on efficiency makes it relatively easy to predict the competition strategies and the consumers' demands and tastes, making ED very low. Another reason could be that the relationship between EO and FP depends on the business group's ED and not on the specific industry of each firm.

Fifth and last, "does ED moderate the relationship between CV and the FP of SCBG?". Contrary to the results of Zahra and Covin (1995), who found that CV efforts are context-specific, highlighting the moderating effect of ED over the relationship between CV and FP (Narayanan et al., 2009), this research is in line with Frank et al. (2010) and Kim and Kim (2016) who also found no evidence that ED moderates the relationship between CV and FP (Fig. 5).

In summary, this research suggests that there are differences between the impact of CE in emerging economies such as the Colombian one and those from developed economies. Additionally, this research proposes that this may be related to the marked differences between these two types of economies, while the Colombian economy is based

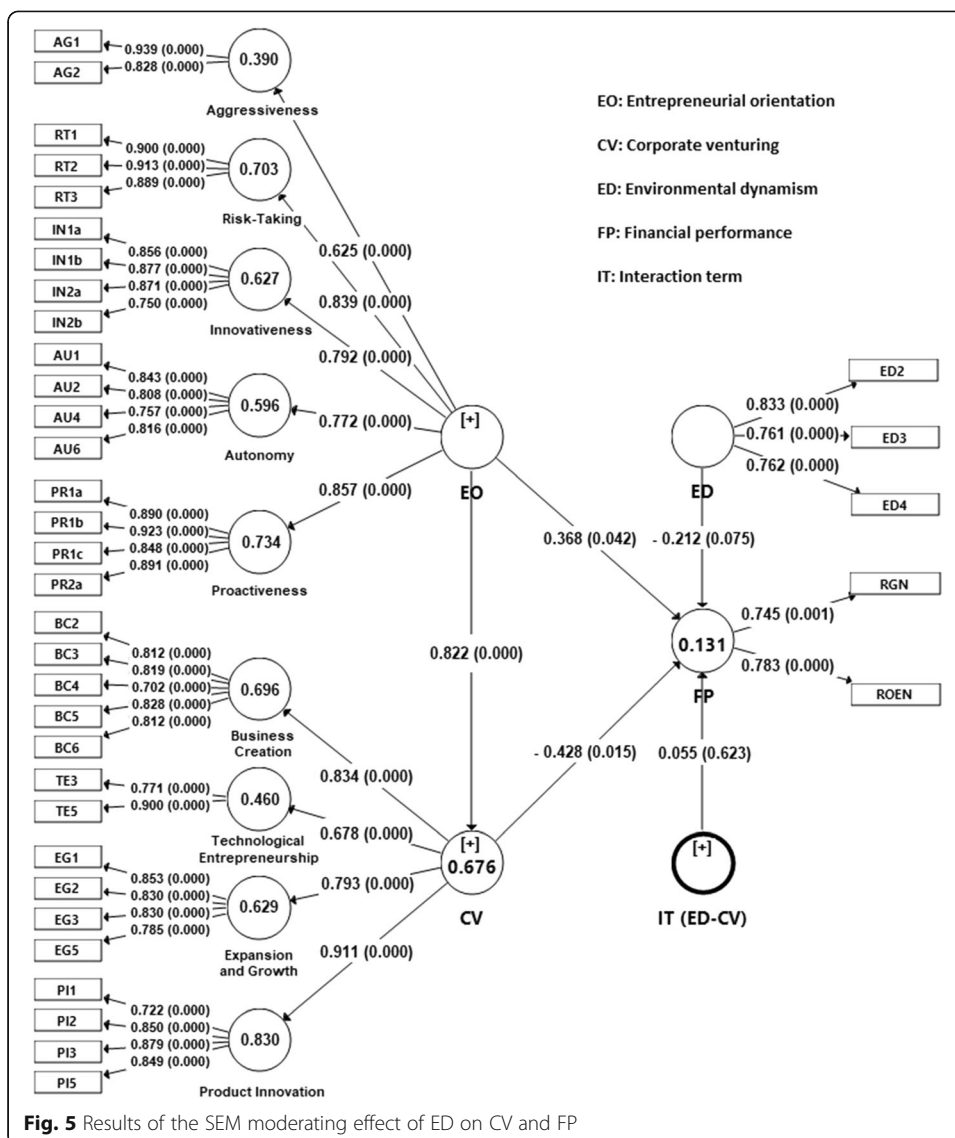

on efficiencies and economies of scale of basic products, without much added value; on the other hand, developed countries support their economies on products unique and innovative, knowledge-based, who are generally pioneers in their field. It also suggests that the above influences the level of ED in a country like Colombia, where it can be very low if viewed from the perspective of product types, if they are basic products, their obsolescence speed is slow and the strategies of the competitors can be quite predictable, as well as customer tastes. Additionally, these results invite researchers to deepen their knowledge about the mechanisms and conditions required to improve the impact of CE on the innovation systems of organizations.

Managerial implications

From a practical perspective, the results contain important insights for managers and consultants of competitiveness, business strategy, open innovation, and CE interested in understanding and improving the business group performance in emerging

economies. This research confirms the existence of interrelationships between EO, CV, and FP. However, the results suggest that business managers should consider that, to successfully carry out CV initiatives that impact positively the FP of companies, high levels of EO are necessary, as well as the development of resources and capabilities that allow ensuring the success of CV projects. This is because CE is a new trend in Colombia and Latin America; then, the firms need to develop the resources and capabilities related to CV mechanisms. In addition, from the organizational structure perspective, companies need to develop capabilities to create better management plans for their innovation talent, for example, a new career development path for innovative employees. Additionally, from the perspective of innovation processes, companies need to improve their skills to create “minimum viable products” that allow them to go to market, controlling risks and skills to audit innovation processes, as well as to create effective innovation teams.

About CV mechanisms, the main ones are acquisitions, corporate venture capital, corporate accelerators and incubators, strategic alliances, venture builder, venture client, scouting missions, hackathons, innovation challenges or contests, and shared resources (Ortega & Rotondo, 2020). About the organizational structure, most organizations usually only have two paths for career development for their employees, such as the technical route and the managerial route. An important competence for strengthening CV is the ability to develop a third path for those employees who wish to direct their career along the CE and innovation line.

From the analysis of the results, it could be inferred that ED, as understood in this research, when associated with the speed of obsolescence of the products, the ease of predicting the movements of the competition and the tastes of the consumers, is very low in Colombia. This is because the majority of Colombian products are basic, without added value, and, in some cases, they are commodities. This condition of ED means that its increases are not yet enough to improve the CE-FP relationship. The foregoing suggests the following implications for public policy makers at the national level, leaders of industrial associations, universities, and business managers in Colombia.

The determinants of public policy are called to strengthen the innovation ecosystem in Colombia, encouraging the development of innovation and entrepreneurship skills from the early stages of citizen training. Additionally, the development of products with greater technological and knowledge-intensive content should be encouraged, which can lead to an increase in companies ED, for example, with tax strategies and investment in research and development, in a way that CV projects can influence positively the FP of the organizations.

The leaders of industrial associations and universities, as part of the country's innovation ecosystem, should be the first to come up with efforts to find fields of technological development, which involve the creation of products with high added value, knowledge-intensive, that help reduce the development gap between emerging economy countries, such as Colombia, and developed countries. The above would contribute to a greater alignment between CV projects and their positive impact on the EO-FP and CV-FP relationship.

Regarding company managers, the research leads to think that they should move towards new practices, such as open innovation and teamwork with startups; this is due

to the advantages that these practices have. Among the advantages are a greater agility in the generation of new business ideas, the high motivation and willingness to risk that the members of a startup have, and the reduction of several limitations for innovation that already consolidated companies have.

This study revealed that the relationship between EO and FP of SCBG is the same for different levels of ED; then, in this context, it does not moderate this relationship. Thus, in the Colombian context, companies that belong to business groups do not perceive effects because of changes in ED, as measured by the research instrument. This may happen because of other factors, endogenous to the country, which considerably affect the company's performance, overshadowing the effect of ED.

Although all the exogenous factors that explain EO are relevant in SCBG, PR is the most important (0.857***), followed by RT (0.839***), IN (0.792***), AU (0.772***), and AG (0.625***), as shown in the measurement model valuation in Table 4 and the results of the SEM in Fig. 2. Likewise, with CV, all the explaining exogenous factors are relevant and significant; however, the managers of SCBG must consider that the most pertinent aspect at the time is the PI (0.911**), followed by the CB (0.834**), EG (0.793**), and the least relevant is TE (0.678**). Then, SCBG's managers must design strategies that allow improving TE, where the results show the greatest weakness, consistent with the dominant products, this is, commodities without added value.

The analysis of results can go down to the detail of each item, for example, PR1b has the greatest weight (0.923**) of PR. This item corresponds to the question “[when dealing with competitors, my company] rarely is the first company to introduce new products/services, administrative techniques, operation technologies. 1 <-> 7 is sometimes the first company to introduce new products/services, administrative techniques, operation technologies?” (Lumpkin & Dess, 2001, p. 442). Thus, the managers of SCBG should give priority to being the first companies to introduce new products/services, administrative techniques, and operation technologies.

On the other hand, considering that the weights for the remaining items of PR (0.8566***) exceed 0.85, and keeping up with their statements, then managers of SCBG may lend priority to being more competitive and staying ahead of their competitors by introducing new ideas and products. From a broader social perspective, an appropriate CE strategy could generate better conditions for employee development, because they are the central actors of innovation. Likewise, for the companies, CE is a competitive advantage that could improve employee retention, because people can perceive a working environment that values their innovation ideas.

Limitations

This study shows limitations that open opportunities for improvement in future research. The main limitations of this research are the quality and size of the sample and the access to financial information of the companies under study. The reliability of the estimated in the model depends on these factors.

Although the sample size exceeds the required for PLS-SEM, its achievement involved collecting 10 times the size of the sample used; from 700 surveys, only 87 met the inclusion criteria. However, this limitation was offset by the quality of the responses. This is based on the characteristics of the sample in terms of their level of

training, the roles they play within the companies, and the age distribution of the respondents. Regarding the training level, 100% are professionals, 50% have specialization training, 20% have master's degrees, and even 1% have a doctorate degree. Also, 43% of those surveyed hold management roles, and 88% of the sample are between 25 and 50 years old (Table 1). The above generates confidence in the data, since these characteristics ensure that the respondents have criteria to evaluate the organizations where they work from different perspectives, lowering the bias that could be generated if the respondents were CEO's at the studied companies.

On the other hand, an important limitation for this research was the access to companies' financial information. The development of this research shows that in Colombia the access to financial information through data centers of a national order is extremely difficult; then, although the data was drawn from the EMIS database, recognized worldwide as the leading provider of data for emerging economies, the quality of data depends on this institution. In order to mitigate this limitation in future research, it is suggested that perception indexes of companies' financial indicators are included; these would be better for triangulating and complementing this information with primary data from the respondents.

Future research directions

This project allowed the identification of several lines of research that could allow the consolidation of a solid knowledge base to strengthen the development of CE and CV projects in Colombia. These lines of research are related to resources and capabilities necessary for CV projects, objectives of CV projects in Colombia, measurement of ED in the country, career development plans for innovative talent in companies, CV mechanisms more recommended for these last, comparison between the innovation ecosystems of emerging countries and developed countries, and the moderating effect of environmental hostility in the CE-FP relationship in Colombian industry. The following are some of the lines of research in which it is necessary to deepen to consolidate CE in Colombia:

- What are the resources and capabilities that companies in Colombia need to develop to improve results in CV projects?
- What kind of objectives do CV projects in Colombia have, strategic or financial? If they are strategic, what are they? (Learning and developing skills, international integration of the company's operations, refining response capacity, establishing better technological and management standards, inspiring internal creation of ideas, and incorporating external knowledge).
- Considering that the results of this research suggest that the moderating effect of ED is not significant in Colombia because of the low ED, it is important to measure it.
- Having in mind that, from an organizational perspective, one of the suggested implications for company managers is the creation of career development plans for innovative talent within the company; this would facilitate open innovation processes and CV projects. In addition, it is important to investigate about of career development plans in outstanding companies in CE. Additionally, it is required an

investigation of the career development plans of Latin American companies that are doing CV projects.

- In order to increase the impact of CV projects in Colombia, it is important to investigate which are the most recommended CV mechanisms for companies. The main ones are acquisitions, corporate venture capital, corporate accelerators and incubators, strategic alliances, venture builder, venture client, scouting missions, hackathons, innovation challenges or contests, and shared resources (Ortega & Rotondo, 2020).
- For CV projects, which are benchmark innovation ecosystems in developed countries, it is necessary to make a competitive comparison with the innovation ecosystem in Colombia.
- Impact of environmental hostility on the EO-FP relation in the Colombian industry.

Conclusions

To summarize, this article has directed greater attention to the impact of CE on the FP of SCBG under the moderating effect of ED in an emerging economy. The results show that the impact of CE on the FP of firms in emerging economies is different than what they appear to be in developed economies. In the same line, this study confirms that the relationship between CE and FP is context-dependent, and that EO has a strong and positive causal relationship to CV. Thus, the relationship between CE and FP in emerging economies differs from the one in developed economies, because of their divergences. The results also suggest that EO is the driving force of CE, and the projects of CV are the results of CE efforts.

Additionally, the results show that ED does not have a moderating effect on the relationship between CE and the FP of SCBG. This is consistent with Kim and Kim (2016), whose “results showed that ED had no significant effect on the EO–FP relationship” (p. 7). It is also consistent with Zhang (2009), who found out that ED does not have a moderating effect on the relationship between EO of 143 subsidiaries of multinationals in China and their FP. On the other hand, the results of this research coincide with those of Frank et al. (2010) and Wiklund and Shepherd (2005), who stated that the moderating effect of ED of the relationship between EO-FP is not significant.

Moreover, this result suggests that Colombian companies have not yet developed enough resources and organizational capabilities that allow them to impact their innovation systems with CV projects, in a way that improves the FP. It is possible that the Colombian CV projects are oriented to strategic benefits and not financial objectives. Furthermore, suggest that the moderating effect of the ED is insignificant in Colombia because the ED is very low. Finally, it is possible that this work represents a motivation for future research that can lead to a greater understanding of how SCBG can guide their CE strategies to generate competitive advantages in the market.

Abbreviations

AG: Aggressiveness; AU: Autonomy; AVE: Average variance extracted; BC: Business creation; CE: Corporate entrepreneurship; CEAI: Corporate Entrepreneurship Assessment Instrument; CV: Corporate venturing; ED: Environmental dynamism; EG: Expansion and growth; EMIS: Emerging Markets Information Service; EO: Entrepreneurial orientation; FP: Financial performance; HTMT: Heterotrait-monotrait; IN: Innovativeness; IT: Interaction term; PI: Product innovation; PLS-SEM: Partial Least Squares-Structural Equation Modeling; PR: Proactiveness; RG: Revenue growth; ROE: Return on equity; RT: Risk-taking; SCBG: Subsidiaries of Colombian business groups; SPSS: Statistical Package for the Social Sciences; TE: Technological entrepreneurship; VIF: Variance inflation factor

Acknowledgements

I am very grateful to my PhD thesis advisor in Strategic Business Administration, Dr. Percy Samoel Marquina Feldman, General Director of CENTRUM PUCP Business School and member of the founding team of CENTRUM PUCP Business School, for all the time, work and talent he generously dedicated to the review of the progress of this paper and my thesis, without which I would never have been able to do it.

I want to thank the editor of the journal as well as the reviewers of my manuscript, whose accurate observations allowed me to give much more meaning to this research. Additionally, I thank each of the students and alumni who supported me and answered the survey.

Author's contributions

AR: conceptualization, methodology, validation, formal analysis, investigation, writing—original draft, and visualization. The author read and approved the final manuscript.

Funding

Not applicable.

Availability of data and materials

The dataset generated and analyzed during the current study are available in the DRIVE repository, [https://drive.google.com/file/d/1Om3MVj-CxGNW_fQVeBQoneiqBk1X-lcz/view?usp=sharing].

Competing interests

The author declares no competing interests.

Received: 19 October 2020 Accepted: 1 February 2021

Published online: 30 June 2021

References

- Alam, M., Nasir, N., & Rehman, C. (2020). Intrapreneurship concepts for engineers: A systematic review of the literature on its theoretical foundations and agenda for future research. *Journal of Innovation and Entrepreneurship*, 9, 8. <https://doi.org/10.1186/s13731-020-00119-3>.
- Ambad, S., & Wahab, K. (2016). The relationship between corporate entrepreneurship and firm performance: Evidence from Malaysian large companies. *International Journal of Business and Society*, 17(2), 259–280. <https://doi.org/10.33736/ijbs.524.2016>.
- Anderson, B., Kreiser, P., Kuratko, D., Hornsby, J., & Eshima, Y. (2015). Reconceptualizing entrepreneurial orientation. *Strategic Management Journal*, 36(10), 1579–1596. <https://doi.org/10.1002/smj.2298>.
- Antoncic, B., & Hisrich, R. (2001). Intrapreneurship: Construct refinement and cross-cultural validation. *Journal of Business Venturing*, 16(5), 495–527. [https://doi.org/10.1016/S0883-9026\(99\)00054-3](https://doi.org/10.1016/S0883-9026(99)00054-3).
- Barringer, B., & Bluedorn, A. (1999). The relationship between corporate entrepreneurship and strategic management. *Strategic Management Journal*, 20(5), 421–444. [https://doi.org/10.1002/\(SICI\)1097-0266\(199905\)20:5<421::AID-SMJ30>3.0.CO;2-O](https://doi.org/10.1002/(SICI)1097-0266(199905)20:5<421::AID-SMJ30>3.0.CO;2-O).
- Battistini, B., Hacklin, F., & Baschera, P. (2013). The state of corporate venturing: Insights from a global study. *Research-Technology Management*, 56(1), 31–39. <https://doi.org/10.5437/08956308X5601077>.
- Bierwerth, M., Schwens, C., Isidor, R., & Kabst, R. (2015). Corporate entrepreneurship and performance: A meta-analysis. *Small Business Economics*, 45(2), 255–278. <https://doi.org/10.1007/s11187-015-9629-1>.
- Birkinshaw, J. (1997). Entrepreneurship in multinational corporations: The characteristics of subsidiary initiatives. *Strategic Management Journal*, 18(3), 207–229.
- Bouchard, V., & Fayolle, A. (2017). *Corporate entrepreneurship*. London: Taylor and Francis. <https://doi.org/10.4324/9781315747989>.
- Campbell, D. F. J., & Carayannis, E. G. (2016). The academic firm: A new design and redesign proposition for entrepreneurship in innovation-driven knowledge economy. *Journal of Innovation and Entrepreneurship*, 5, 12. <https://doi.org/10.1186/s13731-016-0040-1>.
- Carayannis, E. G., Dagnino, G. B., Alvarez, S., & Faraci, R. (Eds.). (2018). *Entrepreneurial ecosystems and the diffusion of startups*. Edward Elgar Publishing. <https://doi.org/10.4337/9781784710064>.
- Carayannis, E. G., Ferreira, J. J., Ferreira, F. A. F., & Peris-Ortiz, M. (2016). Location and innovation capacity in multilevel approaches: Editorial note. *Journal of the Knowledge Economy*, 7(4), 837–841. <https://doi.org/10.1007/s13132-015-0345-5>.
- Carayannis, E. G., & Provan, M. (2018). Towards "skarse" entrepreneurial ecosystems: Using agent-based simulation of entrepreneurship to reveal what makes regions tick. In *Entrepreneurial Ecosystems and the Diffusion of Startups*. Cheltenham, UK: Edward Elgar Publishing. doi: <https://doi.org/10.4337/9781784710064.00013>.
- Cohen, J. (1988). *Statistical power analysis for the behavioral sciences*, (2nd ed.). L. Erlbaum Associates.
- Cohen, J. (1992). A power primer. *Psychological Bulletin*, 112(1), 155–159. <https://doi.org/10.1037//0033-2909.112.1.155>.
- Covin, J., Green, K., & Slevin, D. (2006). Strategic process effects on the entrepreneurial orientation-sales growth rate relationship. *Entrepreneurship Theory and Practice*, 30(1), 57–81. <https://doi.org/10.1111/j.1540-6520.2006.00110.x>.
- Covin, J., & Miles, M. (1999). Corporate entrepreneurship and the pursuit of competitive advantage. *Entrepreneurship Theory and Practice*, 23(3), 47–63. <https://doi.org/10.1177/2F104225879902300304>.
- Covin, J., & Miles, M. (2007). Strategic use of corporate venturing. *Entrepreneurship Theory and Practice*, 31(2), 183–207. <https://doi.org/10.1111/j.1540-6520.2007.00169.x>.
- Covin, J., & Slevin, D. (1989). Strategic management of small firms in hostile and benign environments. *Strategic Management Journal*, 10(1), 75–87. <https://doi.org/10.1002/smj.4250100107>.
- Covin, J., & Slevin, D. (1991). A conceptual model of entrepreneurship as firm behavior. *Entrepreneurship Theory and Practice*, 16(1), 7–25. <https://doi.org/10.1177/104225879101600102>.
- Covin, J. G., Slevin, D. P., & Schultz, R. L. (1994). Implementing strategic missions: Effective strategic, structural and tactical choices. *Journal of Management Studies*, 31(4), 481–506. <https://doi.org/10.1111/j.1467-6486.1994.tb00627.x>.

- De Clercq, D., Dimov, D., & Thongpapanl, N. (2013). Organizational social capital, formalization, and internal knowledge sharing in entrepreneurial orientation formation. *Entrepreneurship: Theory and Practice*, 37(3), 505–537. <https://doi.org/10.1111/etap.12021>.
- De Villiers-Scheepers, M. (2012). Antecedents of strategic corporate entrepreneurship. *European Business Review*, 24(5), 400–424. <https://doi.org/10.1108/09555341211254508>.
- Demirkan, I., Yang, Q., & Jiang, C. (2019). Corporate entrepreneurship of emerging market firms: Current research and future directions. *New England Journal of Entrepreneurship*, 22(1), 5–30. <https://doi.org/10.1108/neje-04-2019-0024>.
- Dess, G., & Lumpkin, G. (2005). The role of entrepreneurial orientation in stimulating effective corporate entrepreneurship. *Academy of Management Perspectives*, 19(1), 147–156. <https://doi.org/10.5465/ame.2005.15841975>.
- Duncan, R. (1972). Characteristics of organizational environments and perceived environmental uncertainty. *Administrative Science Quarterly*, 17(3), 313–327. <https://doi.org/10.2307/2392145>.
- Equipo UDD Ventures (2020). *Corporate venturing Latam handbook: Guía Para la colaboración entre corporaciones y startups*. Retrieved from <https://uddventures.udd.cl/blog/corporate-venturing-latam-handbook-gu%C3%A0-para-la-colaboraci%C3%B3n-entre-corporaciones-y-startups>.
- Falk, R., & Miller, N. (1992). *A primer for soft modeling*. Akron: The University of Akron Press.
- Farinha, L., Ferreira, J. J. M., & Nunes, S. (2018). Linking innovation and entrepreneurship to economic growth. *Competitiveness Review*, 28(4), 451–475. <https://doi.org/10.1108/CR-07-2016-0045>.
- Ferreira, J. J. (2001). Corporate entrepreneurship: A strategic and structural perspective. *New England Journal of Entrepreneurship*, 4(2), 59–70. <https://doi.org/10.1108/NEJE-04-02-2001-B006>.
- Ferreira, J. J. (2010). Corporate entrepreneurship and small firms growth. *International Journal of Entrepreneurship and Small Business*, 10(3), 24. <https://doi.org/10.1504/IJESB.2010.033574>.
- Ferreira, J. J., Carayannis, E. G., Campbell, D. F. J., Farinha, L., Smith, H. L., & Bagchi-Sen, S. (2018). Geography & Entrepreneurship: Managing growth and change. *Journal of the Knowledge Economy*, 9(2), 500–505. <https://doi.org/10.1007/s13132-017-0514-9>.
- Ferreira, J. J., Fernandes, C. I., & Peris-Ortiz, M. (2018). How agents, resources and capabilities mediate the effect of corporate entrepreneurship on multinational firms' performance. *European Journal of International Management*, 12(3), 255–277. <https://doi.org/10.1504/EJIM.2018.091369>.
- Finkle, T. (2012). Corporate entrepreneurship and innovation in Silicon Valley: The case of Google, Inc. *Entrepreneurship Theory and Practice*, 36(4), 863–884. <https://doi.org/10.1111/j.1540-6520.2010.00434.x>.
- Floyd, S., & Wooldridge, B. (1999). Knowledge creation and social networks in corporate entrepreneurship: The renewal of organizational capability. *Entrepreneurship Theory and Practice*, 23(3), 123–144. <https://doi.org/10.1177/104225879902300308>.
- Fornell, C., & Larcker, D. (1981). Evaluating structural equation models with unobservable variables and measurement error. *Journal of Marketing Research*, 18(1), 39–50. <https://doi.org/10.2307/3151312>.
- Frank, H., Kessler, A., & Fink, M. (2010). Entrepreneurial orientation and business performance – A replication study. *Schmalenbach Business Review*, 62(2), 175–198. <https://doi.org/10.1007/BF03396804>.
- Fry, A. (1987). The post-it-note: An intrapreneurial success. *SAM Advanced Management Journal*, 36(4), 4–9.
- Garud, R., Jain, S., & Kumaraswamy, A. (2002). Institutional entrepreneurship in the sponsorship of common technological standards: The case of sun Microsystems and Java. *Academy of Management Journal*, 45(1), 196–214.
- Garvin, D., & Levesque, L. (2006). Meeting the challenge of corporate entrepreneurship. *Harvard Business Review*, 84(10), 102–112,150.
- Gefen, D., Rigdon, E., & Straub, D. (2011). An update and extension to SEM guidelines for administrative and social science research. *MIS Quarterly: Management Information Systems*, 35(2), iii–xiv. <https://doi.org/10.2307/23044042>.
- Geisser, S. (1974). A predictive approach to the random effect model. *Biometrika*, 61(1), 101–107. <https://doi.org/10.1093/biomet/61.1.101>.
- George, G., Wood, J., & Khan, R. (2001). Networking strategy of boards: Implications for small and medium-sized enterprises. *Entrepreneurship and Regional Development*, 13(3), 269–285. <https://doi.org/10.1080/08985620110058115>.
- Guth, W., & Ginsberg, A. (1990). Guest editors' introduction: Corporate entrepreneurship. *Strategic Management Journal*, 11, 5–15.
- Hair, J., Hult, G., Ringle, C., & Sarstedt, M. (2017). *A primer on partial least squares structural equation modeling (PLS-SEM)*, (2nd ed.,). Los Angeles: Sage.
- Hair, J., Risher, J., Sarstedt, M., & Ringle, C. (2018). When to use and how to report the results of PLS-SEM. *European Business Review*, 31(1), 2–24. <https://doi.org/10.1108/EBR-11-2018-0203>.
- Henseler, J., Ringle, C., & Sarstedt, M. (2015). A new criterion for assessing discriminant validity in variance-based structural equation modeling. *Journal of the Academy of Marketing Science*, 43(1), 115–135. <https://doi.org/10.1007/s11747-014-0403-8>.
- Henseler, J., Ringle, C. M., & Sinkovics, R. R. (2009). The use of partial least squares path modeling in international marketing. In R. R. Sinkovics, & P. N. Ghauri (Eds.), *Advances in international marketing*, (pp. 277–319). Emerald Group Publishing Limited. [https://doi.org/10.1108/S1474-7979\(2009\)0000020014](https://doi.org/10.1108/S1474-7979(2009)0000020014).
- Hill, S., Maula, M., Birkinshaw, J., & Murray, G. (2009). Transferability of the venture capital model to the corporate context: Implications for the performance of corporate venture units. *Strategic Entrepreneurship Journal*, 3(1), 3–27. <https://doi.org/10.1002/sej.54>.
- Hind, C., & Steyn, R. (2015). Corporate entrepreneurship-distilling the concept. *The Southern African Journal of Entrepreneurship and Small Business Management*, 7(1), 69–87. <https://doi.org/10.4102/sajesbm.v7i1.7>.
- Ireland, R., Covin, J., & Kuratko, D. (2009). Conceptualising corporate entrepreneurship strategy. *Entrepreneurship Theory and Practice*, 33(1), 19–47. <https://doi.org/10.1111/j.1540-6520.2008.00279.x>.
- Jager, J., Putnick, D., & Bornstein, M. (2017). II. More than just convenient: The scientific merits of homogeneous convenience samples. *Monographs of the Society for Research in Child Development*, 82(2), 13–30. <https://doi.org/10.1111/mono.12296>.
- Kantis, H., & Angelelli, P. (2020). *Grandes empresas, startups e innovación en América Latina: Promesas y desafíos*. Washington D. C: BID.
- Kantis, H. (2018). *Grandes empresas + Startups = nuevo modelo de innovación? Tendencias y desafíos del corporate venturing en América Latina*. Asociación Civil Red Pymes Mercosur.
- Karacaoglu, K., Bayraktaroglu, A., & San, F. (2012). The impact of corporate entrepreneurship on firms' financial performance: Evidence from Istanbul stock exchange firms. *International Business Research*, 6(1), 163–175. <https://doi.org/10.5539/ibr.v6n1p163>.

- Kaya, N. (2006). The impact of human resource management practices and corporate entrepreneurship on firm performance: Evidence from Turkish firms. *The International Journal of Human Resource Management*, 17(12), 2074–2090. <https://doi.org/10.1080/09585190601000204>.
- Kelley, D., Singer, S., & Herrington, M. (2016). *GEM 2015-2016 global report*. Massachusetts: Global Entrepreneurship Monitor (GEM).
- Khanna, T., & Rivkin, J. (2001). Estimating the performance effects of business groups in emerging markets. *Strategic Management Journal*, 22(1), 45–74. [https://doi.org/10.1002/1097-0266\(200101\)22:1<45::AID-SMJ147>3.0.CO;2-F](https://doi.org/10.1002/1097-0266(200101)22:1<45::AID-SMJ147>3.0.CO;2-F).
- Kim, H., & Kim, B. (2016). An entrepreneurial paradox: The moderating effect of the external environment. *Asian Journal of Technology Innovation*. <https://doi.org/10.1080/19761597.2016.1207414>.
- Knight, G. (1997). Cross-cultural reliability and validity of a scale to measure firm entrepreneurial orientation. *Journal of Business Venturing*, 12(3), 213–225. [https://doi.org/10.1016/S0883-9026\(96\)00065-1](https://doi.org/10.1016/S0883-9026(96)00065-1).
- Knox, D. (2019). *Why corporate venture capital is more important than ever for the fortune 500*. Retrieved from Forbes: <https://www.forbes.com/sites/daveknox/2019/11/21/why-corporate-venture-capital-is-more-important-than-ever-for-the-fortune-500/#718f5f3a41af>
- Kock, N., & Hadaya, P. (2018). Minimum sample size estimation in PLS-SEM: The inverse square root and gamma-exponential methods. *Information Systems Journal*, 28(1), 227–261. <https://doi.org/10.1111/isj.12131>.
- Kreiser, P., & Davis, J. (2010). Entrepreneurial orientation and firm performance: The unique impact of innovativeness, proactiveness, and risk-taking. *Journal of Small Business and Entrepreneurship*, 23(1), 39–51. <https://doi.org/10.1080/08276331.2010.10593472>.
- Kuratko, D. (2017). Corporate entrepreneurship 2.0: Research development and future directions. *Foundations and Trends in Entrepreneurship*, 13(6), 441–490. <https://doi.org/10.1561/03000000082>.
- Kuratko, D., Hornsby, J., & Covin, J. (2014). Diagnosing a firm's internal environment for corporate entrepreneurship. *Business Horizons*, 57(1), 37–47. <https://doi.org/10.1016/j.bushor.2013.08.009>.
- Kuratko, D. F., & Audretsch, D. B. (2013). Clarifying the domains of corporate entrepreneurship. *International Entrepreneurship and Management Journal*, 9(3), 323–335. <https://doi.org/10.1007/s11365-013-0257-4>.
- Lee, Y., Zhuang, Y., Joo, M., & Jun, T. (2019). Revisiting Covin and Slevin (1989): Replication and extension of the relationship between entrepreneurial orientation and firm performance. *Journal of Business Venturing Insights*, 12, e00144. <https://doi.org/10.1016/j.jbvi.2019.e00144>.
- Liu, Y., & Vrontis, D. (2017). Emerging-market firms venturing into advanced economies: The role of context. *Thunderbird International Business Review*, 59(3), 255–261. <https://doi.org/10.1002/tie.21900>.
- Lumpkin, G., & Dess, G. (1996). Clarifying the entrepreneurial orientation construct and linking it to performance. *Academy of Management Review*, 21(1), 135–172. <https://doi.org/10.2307/258632>.
- Lumpkin, G., & Dess, G. (2001). Linking two dimensions of entrepreneurial orientation to firm performance: The moderating role of environment and industry life cycle. *Journal of Business Venturing*, 16(5), 429–451. [https://doi.org/10.1016/S0883-9026\(00\)00048-3](https://doi.org/10.1016/S0883-9026(00)00048-3).
- Marcoulides, G., & Saunders, C. (2006). Editor's comments: PLS: A silver bullet? *MIS Quarterly*, 30(2), iii–ix. <https://doi.org/10.2307/25148727>.
- Miller, A., Wilson, B., & Adams, M. (1988). Financial performance patterns of new corporate ventures: An alternative to traditional measures. *Journal of Business Venturing*, 3(4), 287–300. [https://doi.org/10.1016/0883-9026\(88\)90010-9](https://doi.org/10.1016/0883-9026(88)90010-9).
- Miller, D. (1983). The correlates of entrepreneurship in three types of firms. *Management Science*, 29(7), 770–791. <https://doi.org/10.1287/mnsc.29.7.770>.
- Miller, D. (2011). Miller (1983) revisited: A reflection on EO research and some suggestions for the future. *Entrepreneurship Theory and Practice*, 35(5), 873–894. <https://doi.org/10.1111/j.1540-6520.2011.00457.x>.
- Miller, D., & Friesen, P. (1982). Innovation in conservative and entrepreneurial firms: Two models of strategic momentum. *Strategic Management Journal*, 3(1), 1–25. <https://doi.org/10.1002/smj.4250030102>.
- Mohamad, O., Ramayah, T., Puspowarsito, H., Natalisa, D., & Saerang, D. (2011). Corporate entrepreneurship and firm performance: The role of business environment as a moderator. *IUP Journal of Management Research*, 10(3), 7–27.
- Morris, M., Kuratko, D., & Covin, J. (2011). *Corporate entrepreneurship and innovation: Entrepreneurial development within organizations*, (3rd ed.,). Mason: South-Western Cengage Learning.
- Narayanan, V., Yang, Y., & Zahra, S. (2009). Corporate venturing and value creation: A review and proposed framework. *Research Policy*, 38(1), 58–76. <https://doi.org/10.1016/j.respol.2008.08.015>.
- Ortega, L., & Rotondo, A. (2020). *Corporate venturing Latam handbook: Guía Para la Colaboración entre Corporaciones y startups*. Santiago de Chile: Gobierno de Chile.
- Pinchot, G. (1986). Intrapreneuring revisited. *European Management Journal*, 4(2), 89–94. [https://doi.org/10.1016/S0263-2373\(86\)80016-0](https://doi.org/10.1016/S0263-2373(86)80016-0).
- Prats, J., & Siota, J. (2018). *Open innovation, building, scaling and consolidating your firm's corporate venturing unit*. Barcelona: IESE Business School.
- Rauch, A., Wiklund, J., Lumpkin, G., & Frese, M. (2009). Entrepreneurial orientation and business performance: An assessment of past research and suggestions for the future. *Entrepreneurship: Theory and Practice*, 33(3), 761–787. <https://doi.org/10.1111/j.1540-6520.2009.00308.x>.
- Ringle, C., Sarstedt, M., & Straub, D. (2012). Editor's comments: A critical look at the use of PLS-SEM in "MIS quarterly". *MIS Quarterly*, 36(1), iii–xiv. <https://doi.org/10.2307/41410402>.
- Sakhdari, K., & Farsi, J. (2016). Business partners and corporate entrepreneurship in developing countries. *International Journal of Management and Enterprise Development*, 15(1), 61–77. <https://doi.org/10.1504/IJMED.2016.075875>.
- Schaeffer, V. (2015). Corporate entrepreneurship and creativity in large firms: The practice of start-up contests. *Journal of Innovation Economics & Management*, 18(3), 25–51. <https://doi.org/10.3917/jie.018.0025>.
- Sharma, P., & Chrisman, S. (1999). Toward a reconciliation of the definitional issues in the field of corporate entrepreneurship. *Entrepreneurship Theory and Practice*, 23(3), 11–27.
- Siota, J., & Prats, J. (2020). *Corporate venturing latam: Corporate giants' collaboration with start-ups in Latin America*. Barcelona: IESE Business School.
- Stone, M. (1974). Cross-validatory choice and assessment of statistical predictions. *Journal of the Royal Statistical Society. Series B (Methodological)*, 36(2), 111–147.

- Stramaglia, A. (2010). On some "dimensions" of the theory of the firm. *Rivista Internazionale Di Scienze Sociali*, 118(2), 199–223. <https://www.jstor.org/stable/41625250>.
- Tajeddini, K., & Mueller, S. (2018). Moderating effect of environmental dynamism on the relationship between a firm's entrepreneurial orientation and financial performance. *Entrepreneurship Research Journal*, 9(4), 1–13. <https://doi.org/10.1515/erj-2018-0283>.
- Tang, J., Tang, Z., Marino, L., Zhang, Y., & Li, Q. (2008). Exploring an inverted U-shape relationship between entrepreneurial orientation and performance in Chinese ventures. *Entrepreneurship Theory and Practice*, 32(1), 219–239.
- Thomas, A., & Mueller, S. (2000). A case for comparative entrepreneurship: Assessing the relevance of culture. *Journal of International Business Studies*, 31(2), 287–301. <https://www.jstor.org/stable/155638>.
- Tosi, H., Aldag, R., & Storey, R. (1973). On the measurement of the environment: An assesment of the Lawrence and Lorsch enviromental uncertainty subscale. *Administrative Science Quarterly*, 18(1), 27–36. <https://doi.org/10.2307/2391925>.
- Vozikis, G., Bruton, G., Prasad, D., & Merikas, A. (1999). Linking corporate entrepreneurship to financial theory through additional value creation. *Entrepreneurship Theory and Practice*, 24(2), 33–43. <https://doi.org/10.1177/104225879902400204>.
- Wiklund, J. (1999). The sustainability of the entrepreneurial orientation. Performance relationship. *Entrepreneurship Theory and Practice*, 24(1), 37–48. <https://doi.org/10.1177/104225879902400103>.
- Wiklund, J., & Shepherd, D. (2003). Knowledge-based resources, entrepreneurial orientation, and the performance of small and medium-sized businesses. *Strategic Management Journal*, 24(13), 1307–1314. <https://doi.org/10.1002/smj.360>.
- Wiklund, J., & Shepherd, D. (2005). Entrepreneurial orientation and small business performance: A configurational approach. *Journal of Business Venturing*, 20(1), 71–91. <https://doi.org/10.1016/j.jbusvent.2004.01.001>.
- Wilches, G., & Rodríguez, C. (2016). El proceso evolutivo de los conglomerados o grupos económicos en Colombia. *Revista Innovar Journal Revista de Ciencias Administrativas y Sociales*, 26(60), 11–34. <https://doi.org/10.15446/innovar.v26n60.55478>.
- Yiu, D., Lu, Y., Bruton, G., & Hoskisson, R. (2007). Business groups: An integrated model to focus future research. *Journal of Management Studies*, 44(8), 1551–1579. <https://doi.org/10.1111/j.1467-6486.2007.00735.x>.
- Zahra, S. (1993). Environment, corporate entrepreneurship and financial performance: A taxonomic approach. *Journal of Business Venturing*, 8(4), 319–340. [https://doi.org/10.1016/0883-9026\(93\)90003-N](https://doi.org/10.1016/0883-9026(93)90003-N).
- Zahra, S. (1996). Governance, ownership and corporate entrepreneurship: The moderating impact of industry technological opportunities. *The Academy of Management Journal*, 39(6), 1713–1735. <https://doi.org/10.5465/257076>.
- Zahra, S., & Covin, J. (1995). Contextual influences on the corporate entrepreneurship-performance relationship: A longitudinal analysis. *Journal of Business Venturing*, 10(1), 43–58. [https://doi.org/10.1016/0883-9026\(94\)00004-E](https://doi.org/10.1016/0883-9026(94)00004-E).
- Zhang, H. (2009). Conception design and empirical research of multinational subsidiary's entrepreneurial orientation. *IEEE International Conference on Industrial Engineering and Engineering Management (IEEM)*, 1214–1218Scopus. <https://doi.org/10.1109/IEEM.2009.5372991>.
- Zhou, K. Z., Gao, G., & Zhao, H. (2017). State ownership and firm innovation in China: An integrated view of institutional and efficiency logics. *Administrative Science Quarterly*, 62(2), 375–404. <https://doi.org/10.1177/0001839216674457>.

Publisher's Note

Springer Nature remains neutral with regard to jurisdictional claims in published maps and institutional affiliations.

Submit your manuscript to a SpringerOpen[®] journal and benefit from:

- Convenient online submission
- Rigorous peer review
- Open access: articles freely available online
- High visibility within the field
- Retaining the copyright to your article

Submit your next manuscript at ► [springeropen.com](https://www.springeropen.com)
