

Shah, Sahishnu R.; Kumar, Rakesh; Raahemifar, Kaamran; Fung, Alan S.

## Article

# Design, modeling and economic performance of a vertical axis wind turbine

Energy Reports

**Provided in Cooperation with:**

Elsevier

*Suggested Citation:* Shah, Sahishnu R.; Kumar, Rakesh; Raahemifar, Kaamran; Fung, Alan S. (2018) : Design, modeling and economic performance of a vertical axis wind turbine, Energy Reports, ISSN 2352-4847, Elsevier, Amsterdam, Vol. 4, pp. 619-623, <https://doi.org/10.1016/j.egyr.2018.09.007>

This Version is available at:

<https://hdl.handle.net/10419/244151>

### Standard-Nutzungsbedingungen:

Die Dokumente auf EconStor dürfen zu eigenen wissenschaftlichen Zwecken und zum Privatgebrauch gespeichert und kopiert werden.

Sie dürfen die Dokumente nicht für öffentliche oder kommerzielle Zwecke vervielfältigen, öffentlich ausstellen, öffentlich zugänglich machen, vertreiben oder anderweitig nutzen.

Sofern die Verfasser die Dokumente unter Open-Content-Lizenzen (insbesondere CC-Lizenzen) zur Verfügung gestellt haben sollten, gelten abweichend von diesen Nutzungsbedingungen die in der dort genannten Lizenz gewährten Nutzungsrechte.

### Terms of use:

*Documents in EconStor may be saved and copied for your personal and scholarly purposes.*

*You are not to copy documents for public or commercial purposes, to exhibit the documents publicly, to make them publicly available on the internet, or to distribute or otherwise use the documents in public.*

*If the documents have been made available under an Open Content Licence (especially Creative Commons Licences), you may exercise further usage rights as specified in the indicated licence.*



<https://creativecommons.org/licenses/by-nc-nd/4.0/>

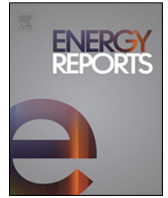

## Research paper

## Design, modeling and economic performance of a vertical axis wind turbine

Sahishnu R. Shah<sup>a</sup>, Rakesh Kumar<sup>b,\*</sup>, Kaamran Raahemifar<sup>a</sup>, Alan S. Fung<sup>b</sup><sup>a</sup> Department of Electrical and Computer Engineering, Ryerson University, Toronto ON M5B 2K3, Canada<sup>b</sup> Department of Mechanical and Industrial Engineering, Ryerson University, Toronto ON M5B 2K3, Canada

## HIGHLIGHTS

- Vertical axis wind turbine was designed, simulated, and analyzed.
- Four Savonius rotors blades rotational performances were compared.
- MATLAB simulation was used to develop an algorithm.
- The new turbine has the capability of producing an annual energy output of 7838 kWh.
- The annual electricity cost/saving in Ontario has been estimated to be \$846.51.

## ARTICLE INFO

## Article history:

Received 4 May 2018

Received in revised form 21 September 2018

Accepted 23 September 2018

Available online 12 October 2018

## Keywords:

Vertical axis wind turbine

Blade design

Power coefficient

Simulation

Annual energy output

## ABSTRACT

Vertical Axis Wind Turbine (VAWT) is relatively simple to implement in urban areas on ground or/and building-roofs, the development of appropriate design of VAWT will open new opportunities for the large-scale acceptance of these machines. The primary objective of this research was to design and modeling of a small-scale VAWT, which can be used to meet the power for low demand applications. Two new shapes of Savonius rotor blades were examined in terms of their rotational performances against the conventional straight and the curved blades. MATLAB simulation was utilized to develop a mathematical model, which comprised of wind power coefficient, tip speed ratio, mechanical and electrical subcomponents. The measured results of developed turbine were used for the validation of the model. The aims were to analyze the turbine blade shapes, develop a mathematical algorithm, and to establish the techno-economic performance of the new curved shape design. It was modeled that the proposed turbine is capable of producing an annual energy output of 7838 kWh and the annual electricity cost/saving in Ontario turned out to be \$846.51 (the price of electricity was taken \$0.108/kWh).

© 2018 The Authors. Published by Elsevier Ltd. This is an open access article under the CC BY-NC-ND license (<http://creativecommons.org/licenses/by-nc-nd/4.0/>).

## 1. Introduction

Wind power has become one of the fastest emerging renewable energy technologies for electricity generation, and the total installed capacity has reached 487 GW (about 4% of the global electricity) by the end of 2016 (Kumar et al., 2018). The development of an effective wind turbine (WT) design, especially for an urban area, is critically needed to increase the penetration of wind power technology in cities and semi-urban areas. Substantial wind is blown in urban areas with a potential of power, viz. highway, railway track, and between/around the high-rise buildings. The wind is blowing continuously with varying intensity in all these areas, and an effective turbine design must include all the site-specific changes in the wind speed, direction, and turbulence.

Two main types of WTs: horizontal axis and vertical axis. Horizontal axis WTs (HAWTs) are widely used in large wind farm applications in remote and offshore areas where the clean and an undisturbed wind is available. Wind patterns in urban areas are more chaotic, less predictable, and full of turbulence, which makes HAWTs relatively ineffective (Walker, 2011; Keith et al., 2013; Toja-Silva et al., 2013; Allen et al., 2008). The Vertical Axis Wind Turbines (VAWTs) might be an effective option in all these areas due to their low cut-in wind speed, no yawing requirement, less structural support, and no noise concerns (Tjiu et al., 2015). Numerous small-scale wind turbine designs have been suggested, tested and implemented in many urbanized areas where the wind is gustier and inconsistent. The efforts have also been undertaken in several countries on VAWT to make them a viable technology. The research and development activities were focused on the design, modeling, integration, sitting, and environmental aspects (Burlando et al., 2015; Danao et al., 2014; Sunderland et al., 2013; Marini et al., 1992). Aerodynamic and economic performances of

\* Corresponding author.

E-mail addresses: [rakesh.kumar@ryerson.ca](mailto:rakesh.kumar@ryerson.ca) (R. Kumar), [kraahemi@ryerson.ca](mailto:kraahemi@ryerson.ca) (K. Raahemifar), [alanfung@ryerson.ca](mailto:alanfung@ryerson.ca) (A.S. Fung).

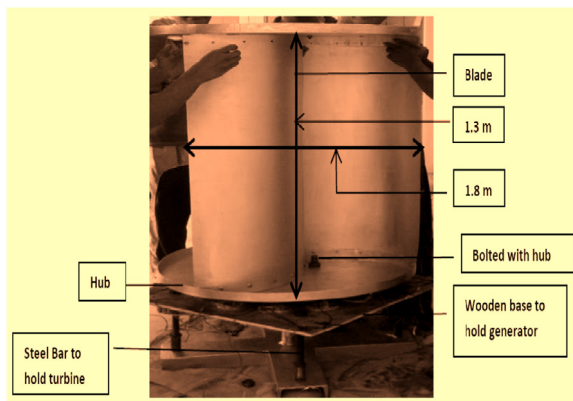

Fig. 1a. A side view of designed and assembled blade configuration of VAWT.

VAWTs have been studied in Iran (Saeidi et al., 2013). The study has revealed that site-specific design considerations could result in improving the cost of energy (COE). Several design techniques of VAWTs were analyzed and discussed by Bhutta et al. (2012). They optimized the coefficient of power ( $C_p$ ) with reference to the tip speed ratio (TSR). Wekesa et al. (2014) have examined the influence of blade design on power output, vibration, and turbine loads. Wenehenubun et al. (2015) have presented the experimental results of Savonius turbine, and the impact of blade numbers were determined on the tip speed ratio, torque, and power coefficient.

It was noted the absence of reliable performance prediction model of VAWTs is considered one of the key hindrances to the widespread acceptance of these machines (Buchner et al., 2015; Burlando et al., 2015; Lee and Lim, 2015). This paper is intended in that direction and involved both experimental and theoretical investigations on VAWT. Savonius turbine blades were redesigned and their rotational performances were analyzed. A comprehensive MATLAB/Simulink simulation model was developed, and the model was validated and applied for the performance evaluation of new design of VAWT.

## 2. Design of turbine

### 2.1. Description of turbine and performance

The design intended that the turbine should have low cut-in wind speed, lightweight, and can be easily moveable. The drag-based machine should be capable of harnessing energy from the non-directional wind at low cut-in speed, which makes it a better choice for many urban applications. Fig. 1 shows a view of the proposed turbine blades and support system. The blades were attached to the hub with the help of three steel bars, and each bar is welded to the center to provide stability to the design. The blade was fabricated from flattened trapezoidal profiled galvanized (GI) steel sheet of equal dimensions (width of each blade = 0.8 m; height of each blade = 1.3 m; the angle between the cross-arm = 120; total height = 1.5 m). A 12 gauge GI sheet has been chosen due to inherent material properties, viz. good tensile and compressive strength, rugged, high stiffness to weight ratio, good resistance to corrosion, and durability. The mild steel is used for the hub, which is connected to the main shaft. The main shaft is also made of a mild steel rod. The shaft is passed through the two bearings and connected to the shaft of the generator with the help of a coupling arrangement. The generator is rested on the wooden base, which is supported by the three steel bars on the ground.

The shaft is connected to an AC permanent magnet generator (PMG) to produce the electrical output. An electrical converter is used to convert low voltage AC into high-quality DC power for

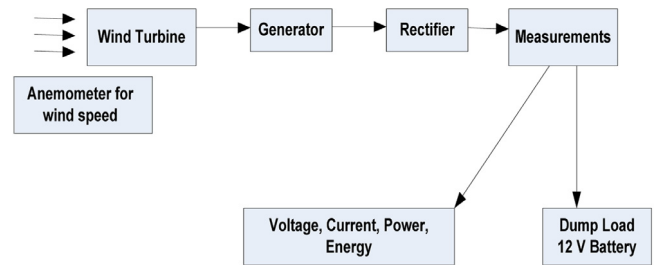

Fig. 1b. A block diagram of experimental measurement setup.

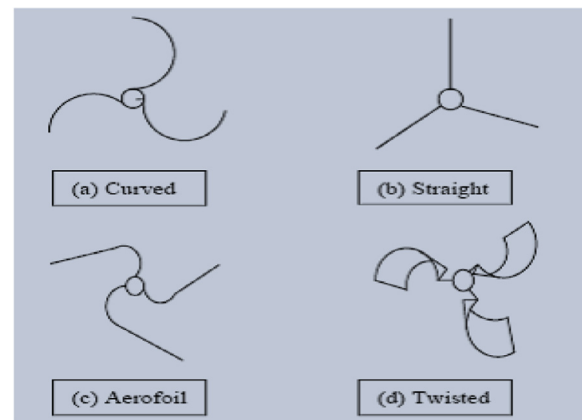

Fig. 2. A sectional view of tested blade designs.

battery charging. The rectifier provides a constant voltage at the battery terminal. The other parts of the machine are a mechanical shaft, stator, two magnet rotors, and a rectifier. The electrical outputs were measured by transducers and subsequently fed to the dump load (12 V DC batteries). The current and voltage were recorded with high accuracy at the outlet of the rectifier, and an anemometer was used for the measurement of wind speed. The accuracy of measured power was estimated 0.5%, whereas the accuracy of anemometer was taken from the product specifications (3%).

### 2.2. Rotational performance of the tested blade configurations

The simplest design of VAWTs is the Savonius rotor, which works like a cup anemometer. The design has been accepted because it requires relatively low cut-in wind speeds. Savonius rotors are a drag-type machine, consisting of two or three blades. Savonius rotors with four shapes were tested, and their relative rotational performances have been analyzed. The experiments were conducted for the curved, straight, aerofoil, and twisted blade shapes (Shah, 2014; Kumar et al., 2018). A sectional view of tested blades is shown in Fig. 2.

The rotations per minute (RPM) for each blade types were recorded with respect to wind speed and illustrated in Fig. 3. The straight blade was found to have lowest RPM in all four shapes while the best RPM has been posted for the twisted blade. In respect to the wind speed, the straight blade has been seen to have less efficiency in comparison to other three blades shapes. The reason for this is there is a more drag force acting on the straight blades, separated by 120°, relative to the other three configurations. The same speed of wind produces the lesser amount of torque for straight blade shape. The rotational performance for the curved blade type was closer to the twisted type, whereas, the aerofoil blade has lower RPM than the twisted and curved blades. The subsequent theoretical and experimental studies were carried out only for the curved shape blade configuration.

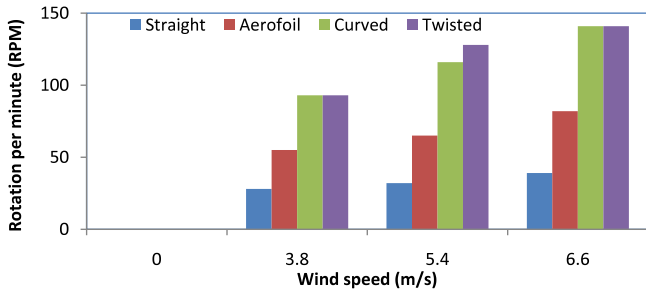

Fig. 3. Variation of RPM with air velocity for the tested blades. (The Figure was recreated from the source data with permission, Shah, 2014; Kumar et al., 2018).

### 3. Simulation model

The output power of wind turbine depends on the wind speed, the swept area, aerodynamic, mechanical, electrical. A mathematical model was developed in MATLAB to advance the proposed design (Kacprzak et al., 2013). The energy flow has been written for various subcomponents of the turbine. The developed model of the turbine can be envisioned in the following three subcomponents: (1) power coefficient (aerodynamics performance), (2) mechanical power (mechanical performance) and (3) electrical performance.

#### Power coefficient (aerodynamic performance)

The power coefficient ( $C_p$ ) represents the amount of power that can be extracted from the wind.  $C_p$  is estimated by using equation (Kusiak and Song, 2010):

$$C_p = C_1 \left( \frac{C_2}{\lambda_1} - C_3\beta - C_4 \right) e^{-\frac{C_5}{\lambda_1}} + C_6\lambda \quad (1)$$

where  $C_1 = 0.5176$ ,  $C_2 = 116$ ,  $C_3 = 0.4$ ,  $C_4 = 5$ ,  $C_5 = 21$  and  $C_6 = 0.0068$  are constant coefficients.  $\lambda$  is tip speed ratio (TSR) and  $\beta$  is the pitch angle (Kumar et al., 2018). A block diagram for the estimation of  $C_p$  is given in Fig. 4. The tip speed ratio ( $\lambda$ ) is defined as the ratio of the peripheral speed of the tip of the blade to the wind speed.  $\lambda$  is calculated by using the following equation,

$$\lambda = \frac{R \times \omega}{v} \quad (2)$$

where  $\omega$  is the rotational speed of turbine (rad/s),  $R$  is the radius (m), and  $v$  is the wind speed (m/s). The parameter  $\lambda_1$  is defined as,

$$\frac{1}{\lambda_1} = \frac{1}{\lambda + 0.08\beta} - \frac{0.035}{\beta^3 + 1} \quad (3)$$

#### Mechanical power subsystem

The mechanical power of turbine is expressed in terms of the following equation,

$$P_m = \frac{1}{2} \times C_p \rho A v^3 \quad (4)$$

where  $P_m$  is the mechanical power of the turbine (W),  $C_p$  is the wind power coefficient,  $A$  is the swept area of turbine ( $m^2$ ),  $\rho$  is the density of air ( $kg/m^3$ ), and  $v$  is wind speed (m/s). The corresponding mechanical torque ( $T_m$ ) and torque coefficient ( $C_Q$ ) can be evaluated by the following equations,

$$T_m = \frac{P_m}{\omega} = \frac{1}{2} \times C_p \rho A v^2 \left( \frac{R}{\lambda} \right) \quad (5)$$

$$C_Q = \frac{C_p}{\lambda} \quad (6)$$

#### Electrical energy from the generator

The next step in the design process is the conversion of mechanical power into electrical energy. PMG is designed with multi magnetic poles and considered effective even for low rotational speed.

Table 1

Expressions for various parameters used in the simulation.

Parameter	Mathematical relation	Parameter	Mathematical relation
Fitch factor	$k_p = \sin\left(\frac{180P_m}{2Q}\right)$	Induce current	$I = \frac{P_m}{3 \times E_{LN}}$
Distribution factor	$k_d = \frac{\sin(q\frac{\pi}{2})}{q \times \sin(\frac{\pi}{2})}$	Copper losses	$P_{losses}^{Cu} = 3RI^2$
Winding factor	$k_w = k_d k_p$	Iron losses	$P_{losses}^{Fe} = k_h B_{max}^2 f_{elec} + k_c B_{max}^2 f_{elec}^2 + k_e B_{max}^{3/2} f_{elec}^{-3/2}$
Mechanical frequency	$f_{mech} = \frac{\omega}{2\pi}$	Total losses	$P_{losses}^{total} = P_{losses}^{Cu} + P_{losses}^{Fe}$
Electrical frequency	$f_{elec} = \frac{\omega}{4\pi} \times p$	Net power from generator	$P_t = P_m - P_{losses}^{total}$
Induced phase voltage	$E_{LN} = \sqrt{2}\pi f_{elec} n \phi k_w$	Efficiency of generator	$\eta = \frac{P_t}{P_m}$
Induced line voltage	$E_{LL} = \sqrt{3}E_{LN}$		

This subsystem has accounted for the copper losses, iron losses, mechanical frequency, electrical frequency, induce voltage, induce current, net electrical power and efficiency (Kurt et al., 2014). Table 1 shows the mathematical equations for the estimation of electrical energy. All these mathematical relations are written in the Matlab script for the evaluation of net electrical power.

### 4. Performance results

A programming script was written in the MATLAB/Simulink to analyze the performance of proposed turbine design numerically. The numerical values were implemented in the model, and the outputs were examined. Output voltage and current waveforms of the model were analyzed, and the simulated values of voltage, current, and power were estimated and compared with experimental results. The calculation for electrical power output and annual energy generated at various predictable wind speeds were also made. Subsequently, the model was used to evaluate the impacts of wind speed and tip speed ratio on the power and torque coefficients.

Figs. 5–6 shows a comparison of model outputs with measured values under identical conditions. The estimated total power generated from the model at 7 m/s wind speed turned out to be 367.2 W while the corresponding measured value was recorded at 327.5 W. It is evident the modeling results are reasonably close to the measured values. The minor differences in the two values may be interpreted in terms of the uncontrolled test conditions, turbulence effect in the wind, and the measurement errors.

The annual energy output of the proposed turbine was estimated (Table 2). The operating range of the turbine was taken 1 m/s to 17 m/s, and the turbine produces its rated power at 9 m/s. There was no energy generation from the turbine if the wind speed is less than 3 m/s (cut-in wind speed), on the other hand, the turbine ceases its power generation at 17 m/s (cut-out wind speed). The annual energy output turned out to be 7838 kWh, and the corresponding annual revenue was estimated \$846.51 (with 20 years contract price under feed-in-tariff \$0.108/kWh). The prevailing market price of these small turbine varies between \$1000 to \$3000, depending on several factors. Besides, there will be some expenses on operational and maintenance. If we assumed, the total cost of the proposed design is \$3000. The simple payback will be turned out 3.5 years, and the turbine will generate a net income of \$13,967.4 in 20 years life-span.

Furthermore, the model was applied to see the impacts of TSR on the power and torque coefficients (Fig. 7). The power coefficient varies from 0 to 0.46 (and corresponding torque coefficient

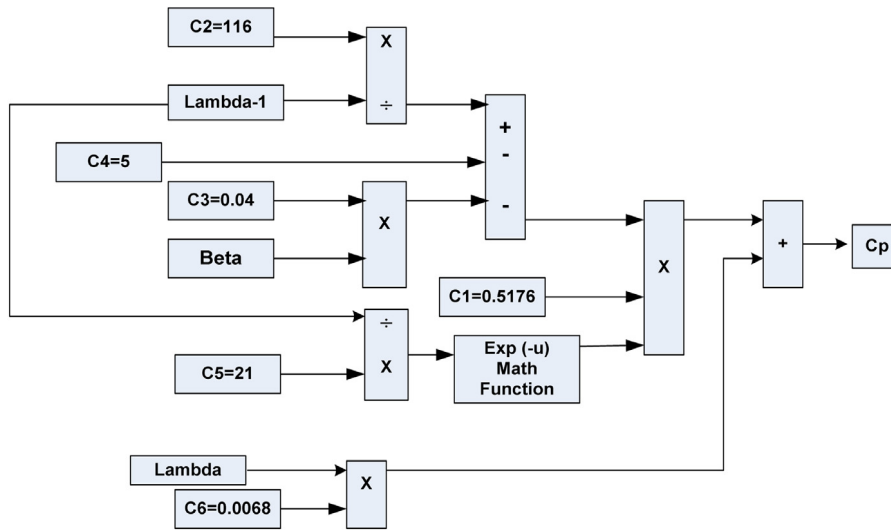

Fig. 4. The simulation block diagram for the calculation of  $C_p$ .

**Table 2**  
The power, annual energy, and economic performance of proposed turbine.

Wind speed (m/s)	No of hours/Year (h)	Rayleigh wind probability	Wind power (W)	Electrical power (W)	Annual energy (kWh)	Revenue generation (\$0.108/kWh)
1	131	0.015	1.17	0.81	0	0
2	184	0.021	9.37	8.41	0	0
3	272	0.031	31.61	29.39	7.98	0.86
4	531	0.06063	74.92	70.04	37.20	4.01
5	729	0.0832	146.34	136.33	99.36	10.73
6	869	0.0992	252.87	233.92	203.27	21.95
7	940	0.1073	401.55	368.19	346.08	37.37
8	946	0.108	599.40	544.22	514.87	55.60
9	917	0.1047	753.44	766.76	703.25	75.95
10	806	0.092	753.44	1040.29	838.39	90.54
11	689	0.0787	753.44	1368.98	943.79	101.92
12	562	0.0641	753.44	1756.68	986.41	106.53
13	418	0.0477	753.44	2206.98	922.19	99.59
14	335	0.0382	753.44	2723.12	911.24	98.41
15	199	0.0227	753.44	3308.08	657.82	71.04
16	168	0.0192	753.44	3964.51	666.78	72.01
≥ 17	65	0.00737			0	0

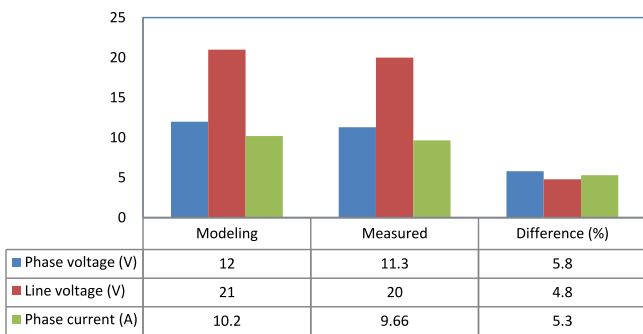

Fig. 5. A comparison of measured and simulated values of voltages and currents.

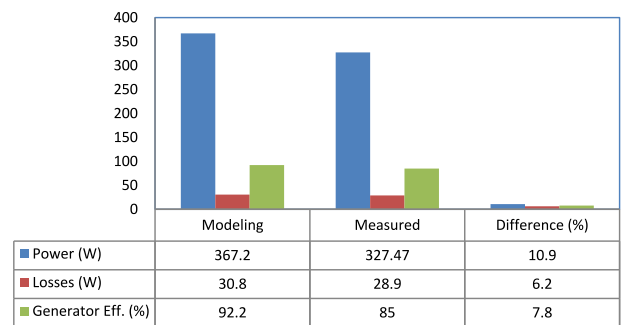

Fig. 6. A comparison of measured and simulated values of power, losses, and efficiency.

changes 0.001 to 0.06) as the TSR changes from 0.05 to 2.5. As mentioned, tip speed ratio is the ratio of the speed of turbine tip to the wind speed, it means if the tip speed ratio is too low (less than 1.65), more wind passes through the turbine blades without converting into useful energy, while if the tip speed ratio is too high (more than 1.65), the turbine blades behave like a solid object to the wind and a reduction in the rotor efficiency occurs due to the tip and drag losses.

### 5. Conclusions

Four different Savonius rotor blade types were tested and analyzed for their rotational performances. The straight blade is found to be least effective in all four designs while the best performance was seen for the twisted blade type. The performance of the developed design was recorded in the laboratory and used for the validation of the model. It was observed that the simulation results are in

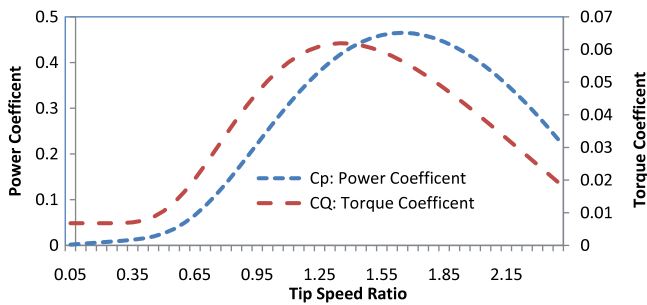

Fig. 7. Variation of power and torque coefficients vs. TSR.

a reasonable agreement with the measured values. The differences in the measured and modeled values may be understood in terms of the uncontrolled test conditions and the measurement errors. The economic viability of the design is also evaluated in terms of annual energy output, and it was estimated that the design could generate the annual energy of 7838 kWh, and the corresponding annual revenue was estimated \$846.51.

#### Nomenclature

$B_{\max}$	Maximum magnetic flux density
$E$	Effective value of the induced phase voltage (RMS)
$E_{LN}$	Effective value of the induced phase voltage (RMS)
$f_{\text{mech}}$	Mechanical frequency
$f_{\text{elec}}$	Electrical frequency
$I$	Generated current
$k_w$	Winding factor
$n$	Number of conductor per phase in stator
$P$	Number of poles
$P_m$	Mechanical power from turbine (W),
$P_{\text{losses}}^{\text{Cu}}$	Copper losses (W)
$P_{\text{losses}}^{\text{Fe}}$	Iron losses (W)
$P_t$	Net power from generator (W)
$P_{\text{losses}}^{\text{total}}$	Total losses (W)
$q$	Number of cable slots per poles per phase
$Q$	Number of slots in the stator
$R$	Radius of the turbine (m), Resistive losses in copper wire ( $\Omega$ )
$v$	Wind velocity (m/s)
$w$	Rotational speed of turbine (rad/s)
$\lambda$	Tip speed ratio
$\omega_{\text{mech}}$	Angular frequency
$\alpha$	Angle between slots
$\phi$	Magnetic flux
$\phi$	Magnetic flux
$\eta$	Efficiency of generator

#### Abbreviations

VAWT	Vertical Axis Wind Turbine
HAWT	Horizontal Axis Wind Turbine
PMG	Permanent Magnet Generator
PWM	Pulse Width Modulating
RPM	Rotation per Minute
TSP	Tip Speed Ratio

#### Acknowledgment

The authors gratefully acknowledge the financial support provided by the Natural Sciences and Engineering Research Council of Canada and Hydro One.

#### References

- Allen, S.R., Hammond, G.P., McManus, M.C., 2008. Prospects for and barriers to domestic micro-generation: A United Kingdom perspective. *Appl. Energy* 85, 528–544.
- Bhutta, M.M.A., Hayat, N., Farooq, A.U., Ali, Z., Jamil, S.R., Hussain, Z., 2012. Vertical axis wind turbine—a review of various configurations and design techniques. *Renewable Sustainable Energy Rev.* 16, 1926–1939.
- Buchner, A.J., Lohry, M.W., Martinelli, L., Soria, J., Smit, A.J., 2015. Dynamic stall in vertical axis wind turbines: Comparing experiments and computations. *Wind Eng. Ind. Aerodyn.* 146, 163–171.
- Burlando, M., Ricci, A., Freda, A., Repetto, M.P., 2015. Numerical and experimental methods to investigate the behaviour of vertical-axis wind turbines with starters. *Wind Eng. Ind. Aerodyn.* 144, 125–133.
- Danao, L.A., Edwards, J., Eboibi, O., Howell, R., 2014. A numerical investigation into the influence of unsteady wind on the performance and aerodynamics of a vertical axis wind turbine. *Appl. Energy* 116, 111–124.
- Kacprzak, K., Liskiewicz, G., Sobczak, K., 2013. Numerical investigation of conventional and modified Savonius wind turbines. *Renew. Energy* 60, 578–585.
- Keith, M., Sunderland, G.M., Michael, F.C., 2013. Estimating the wind resource in an urban area: A case study of micro-wind generation potential in Dublin, Ireland. *Wind Eng. Ind. Aerodyn.* 118, 44–53.
- Kumar, R., Kaamran, R., Fung, A.S., 2018. A critical review of vertical axis wind turbines for urban applications. *Renewable Sustainable Energy Rev.* 89, 281–291.
- Kurt, E., Gör, H., Demirtaş, M., 2014. Theoretical and experimental analyses of a single phase permanent magnet generator (PMG) with multiple cores having axial and radial directed fluxes. *Energy Convers. Manage.* 77, 163–172.
- Kusiak, A., Song, A., 2010. Design of wind farm layout for maximum wind energy capture. *Renew. Energy* 35, 685–694.
- Lee, Y.T., Lim, H.C., 2015. Numerical study of the aerodynamic performance of a 500 W Darrieus-type vertical-axis wind turbine. *Renew. Energy* 83, 407–415.
- Marini, M., Massardo, A., Satta, A., 1992. Performance of vertical axis wind turbines with different shapes. *Wind Eng. Ind. Aerodyn.* 39, 83–93.
- Saeidi, D., Sedaghat, A., Alamdari, P., Alemrajabi, A.A., 2013. Aerodynamic design and economical evaluation of site specific small vertical axis wind turbines. *Appl. Energy* 101, 765–775.
- Shah, S., 2014. Small scale vertical axis wind turbine (M.Eng. thesis). Submitted to Ryerson University, Toronto, Canada, Available on: <https://digital.library.ryerson.ca/islandora/object/RULA:4280> [Accessed 19 September 2018].
- Sunderland, K., Woolmington, T., Blackledge, J., Conlon, M., 2013. Small wind turbines in turbulent (urban) environments: A consideration of normal and Weibull distributions for power prediction. *Wind Eng. Ind. Aerodyn.* 121, 70–81.
- Tjiu, W., Marnoto, T., Mat, S., Ruslan, M.H., Sopian, K., 2015. Darrieus vertical axis wind turbine for power generation: Assessment of Darrieus VAWT configurations. *Renew. Energy* 75, 50–67.
- Toja-Silva, F., Colmenar-Santos, A., Castro-Gil, M., 2013. Urban wind energy exploitation systems: Behavior under multidirectional flow conditions - Opportunities and challenges. *Renewable and Sustainable Energy Reviews* 24, 364–378.
- Walker, S.L., 2011. Building mounted wind turbines and their suitability for the urban scale—A review of methods of estimating urban wind resource. *Energy Build.* 43, 1852–1862.
- Wekesa, D.W., Wang, C., Wei, Y., Danao, L.A.M., 2014. Influence of operating conditions on unsteady wind performance of vertical axis wind turbines operating within a fluctuating free-stream: A numerical study. *Wind Eng. Ind. Aerodyn.* 135, 76–89.
- Wenehenubun, F., Saputra, A., Sutanto, H., 2015. An experimental study on the performance of Savonius wind turbines related with the number of blades. *Energy Procedia* 68, 297–304.