

Yu, Dongmin; Wang, Yong; Liu, Huanan; Kittisak Jernsittiparsert; Razmjoo, Navid

Article

System identification of PEM fuel cells using an improved Elman neural network and a new hybrid optimization algorithm

Energy Reports

Provided in Cooperation with:

Elsevier

Suggested Citation: Yu, Dongmin; Wang, Yong; Liu, Huanan; Kittisak Jernsittiparsert; Razmjoo, Navid (2019) : System identification of PEM fuel cells using an improved Elman neural network and a new hybrid optimization algorithm, Energy Reports, ISSN 2352-4847, Elsevier, Amsterdam, Vol. 5, pp. 1365-1374,
<https://doi.org/10.1016/j.egy.2019.09.039>

This Version is available at:

<https://hdl.handle.net/10419/243676>

Standard-Nutzungsbedingungen:

Die Dokumente auf EconStor dürfen zu eigenen wissenschaftlichen Zwecken und zum Privatgebrauch gespeichert und kopiert werden.

Sie dürfen die Dokumente nicht für öffentliche oder kommerzielle Zwecke vervielfältigen, öffentlich ausstellen, öffentlich zugänglich machen, vertreiben oder anderweitig nutzen.

Sofern die Verfasser die Dokumente unter Open-Content-Lizenzen (insbesondere CC-Lizenzen) zur Verfügung gestellt haben sollten, gelten abweichend von diesen Nutzungsbedingungen die in der dort genannten Lizenz gewährten Nutzungsrechte.

Terms of use:

Documents in EconStor may be saved and copied for your personal and scholarly purposes.

You are not to copy documents for public or commercial purposes, to exhibit the documents publicly, to make them publicly available on the internet, or to distribute or otherwise use the documents in public.

If the documents have been made available under an Open Content Licence (especially Creative Commons Licences), you may exercise further usage rights as specified in the indicated licence.



<https://creativecommons.org/licenses/by/4.0/>



Research Paper

System identification of PEM fuel cells using an improved Elman neural network and a new hybrid optimization algorithm

Dongmin Yu ^{a,b}, Yong Wang ^{a,b}, Huanan Liu ^{a,b}, Kittisak Jermstipsart ^{c,d,*}, Navid Razmjoo ^e

^a Key Laboratory of Modern Power System Simulation and Control & Renewable Energy Technology, Ministry of Education (Northeast Electric Power University), Jilin 132012, China

^b Electric Power Research Institute of China, Haidian District, Beijing 100085, China

^c Department for Management of Science and Technology Development, Ton Duc Thang University, Ho Chi Minh City, Vietnam

^d Faculty of Social Sciences and Humanities, Ton Duc Thang University, Ho Chi Minh City, Vietnam

^e Department of Electrical Engineering, Tsfresh University, Tafresh, Iran



ARTICLE INFO

Article history:

Received 27 July 2019

Received in revised form 30 August 2019

Accepted 14 September 2019

Available online 30 September 2019

Keywords:

Proton exchange membrane fuel cell

Parameter identification

Optimization

WCO

FSO

Improved Elman neural network

ABSTRACT

Parameter identification of the proton exchange membrane fuel cell (PEMFC) is a good way of increasing their efficiency in the next designs. In this study, an optimized improved Elman neural network based on a new hybrid optimization algorithm is proposed for this purpose. The proposed algorithm is a hybrid algorithm based on a combination of two newly algorithms, the world cup optimization (WCO) and the fluid Search Optimization (FSO) algorithms. The proposed method is applied to improve the method efficiency for estimating the PEMFC model parameters. The method is then validated by four different operational conditions. The optimization algorithm efficiency is also analyzed by comparison with some popular algorithms. Simulation results showed that using the designed method gives higher accuracy forecast for the PEMFC model parameters.

© 2019 The Authors. Published by Elsevier Ltd. This is an open access article under the CC BY license (<http://creativecommons.org/licenses/by/4.0/>).

1. Introduction

Recently, energy has been turned into a driving force for comprehensive economic development in all countries which makes the use of available energy sources as a major factor in the economic development of post-human societies (Mirzapour et al., 2019; Ahadi et al., 2015; Aghajani and Ghadimi, 2018). Concerns have been raised about the increase in fossil fuel prices and the limited amount of them (Ghadimi et al., 2018; Khodaei et al., 2018; Bagal et al., 2018). In addition, the impact of these fuels on the environmental changes and environmental degradation by pollutants from exploiting these energy sources are also important. Unlike fuel cells, renewable energies because of the ability for reusing in nature have become the most widely used fuels (Saeedi et al., 2019).

Recently, the usage of the fuel cell (FC) has been exponentially increasing. A fuel cell is a power generation component which converts the chemical power directly into the electrical power and the heating power (Saeedi et al., 2019; Abedinia et al., 2019). This type of source energy is widely used as the promising portable plant especially in portable and motionless

applications like electric vehicles and UAVs (Liu et al., 2017; Jjaodola et al., 2019). Polymer electrolyte membrane (PEM) has become a promising model against the other types of fuel cells based on its characteristics.

The features like fast operation, no contamination, low operational temperature, and especially their high efficiency makes them be one of the proper candidates for power generation. Recently, several works have been performed for improving the efficiency of the constructional designing in PEMFCs.

These works include different features of the system like the steady-state stability, study on the dynamic models of the system and empirical data from the experiments (Sun et al., 2015; Eslami et al., 2019; El-Hay et al., 2019).

In 1991, Springer et al. proposed a steady-state and one dimensional model for the PEMFC (Springer et al., 1991). The authors also presented an isothermal and steady-state model for the PEMFC.

In 2010, Caux et al. presented provided a state-space identification method for energy management in HEVs (Caux et al., 2010). They also consider the control process of the fuel cell's temperature and gas flows. In addition, some research works have been performed over the modeling of PEMFC (Bao and Bessler, 2015; Solsona et al., 2017).

* Corresponding author.

E-mail address: kittisak.jermstipsart@tdtu.edu.vn (K. Jermstipsart).

In 2017, Solsona et al. presented an empirically validated model for a low-temperature PEMFC by considering the humidifier in the model (Solsona et al., 2017). The control method was a control-oriented model of a Nafion® membrane. Final results were compared with the experimental results.

In 2014, Panagiotis et al. presented two dynamical models based on the semi-empirical formulas and the electrical equivalent for PEMFC (Papadopoulos et al., 2014). In addition, an improved model based on a transfer function by considering semi-empirical equations was proposed. The main purpose was to propose a parametric analysis for models ability.

In 2017, Kumar et al. proposed a real-time model for PEMFC and then they analyzed the modality of the method by different validation like ARX and ARMAX (Kumar et al., 2018). MATLAB toolbox was utilized for system identification. PI and PID controllers were also utilized for obtaining the desired load current.

Although the aforementioned models are useful for designing and performance analysis of the fuel cells, there are some limitations for them.

Most of the proposed methods are based on accurate modeling of the fuel cells that is based on the physical concepts of the fuel cells such as thermodynamics, momentum's conservation, power, and mass to obtain an accurate thermal model for anything that happens in them.

Using these kinds of formulation make the model so complicated. There are even some parameters that cannot be measured for the model. Therefore, using these methods is not a proper strategy for modeling the fuel cells, especially in real-time applications.

Due to the ability of the neural networks for solving the nonlinear and complicated dynamic models, they become into an efficient tool for solving nonlinear systems like PEMFCs (Tao et al., 2005; Hatti and Tioursi, 2009; Rezazadeh et al., 2010).

In 2016, Razmjoooy and Ramezani used an improved model of the neural network for optimal system identification (Razmjoooy and Ramezani, 0000). They used a new hybrid WNN based on Gravitational Search Algorithm for this purpose. Simulation results showed that the proposed method can improve the performance of the neural network.

In 2016, Abbaspour et al. presented a robust control method using a neural network for polymer electrolyte membrane PEMFCs (Abbaspour et al., 2016). The proposed robust method was used because the changes between the partial pressure of oxygen and hydrogen in PEMFCs may cause serious damages.

Because of the PEMFC nonlinearities in its dynamic, they used a neural network for regulating the system. Experimental results showed that the neural network-based system can improve system efficiency.

In 2011, Steiner et al. presented a technique for the fault detection of a Polymer Electrolyte Fuel Cell (PEFC) using the Elman Neural Network (ENN) (Steiner et al., 2011). Because of the numerous principal parameters in the PEFCs, they need a strong method for identification. In this paper, a technique for water management problems in PEFC including drying out and flooding based on some significant parameters was proposed for simplifying the identifying process.

In 2011, Wu et al. proposed a control method based on power decoupling for a hybrid gas turbine and a solid oxide fuel cell (SOFC) (Wu et al., 2011). Because of the nonlinear substance of the system, to follow the load profile by the proposed system, a self-tuning PID based on Elman neural network was utilized. Particle Swarm Optimization (PSO) algorithm is also used for obtaining the optimum solution in the system.

Results showed that the presented methodology can obtain promising performance toward the other state of the art methods.

Literature review shows that using the optimization algorithms improves the neural networks efficiency. The main idea

behind this is that they can escape from the local minimum which leads them to obtain almost the global optimum (Razmjoooy et al., 2016; Razmjoooy and Ramezani, 2014; Namadchian et al., 2016).

Therefore, in this paper, we addressed two parts for improving the system performance in the PEMFC Identification. First, a modified Elman neural network is introduced and used for the system parameters identification and after that, a new hybrid algorithm is introduced and utilized to achieve a better solution from the system.

In the proposed method, the features of two new optimization algorithm, called fluid Search Optimization algorithm and world cup optimization algorithm have been synthesized. Finally, for preventing the new algorithm from the premature convergence, chaos theory has been utilized.

The proposed hybrid chaos FSOWCO based improved ENN method is utilized for solving the nonlinear modeling of a PEMFC.

The remained part of the paper is as follow: in Section 2, the material methods of the study, including Elman neural networks and the proposed FSO algorithm are described. Section 3 determines a validation of the modified FSO algorithm. Section 4 describes the methodology validation by Proton Exchange Membrane. Section 5 explains about the optimal modified ENN based on MFSO algorithm and the paper is concluded by Section 6.

2. Materials and methods

2.1. Elman neural networks

In this subsection, the modeling of the PEMFC by the Elman neural network (ENN) is provided. The Elman neural network includes 4 main layers: the input layer, the context layer, the hidden layer, and the output layer.

The main configuration of this neural network is like the feedforward neural networks such that connection in the input layer, the hidden layer, and the output layer is completely similar to the multi-layer neural network.

Besides, there is another layer in ENN that is called the context layer such that its inputs come from the outputs of the hidden layer for storing the previous values of the hidden layer.

Fig. 1 shows a simple structure of an ENN.

The external input, context weight, and the output weight matrices are defined by W_h^i , W_h^c , W_h^o , respectively.

By considering the form of ENN from Fig. 1, the dimension of the input and the output layers are n , i.e. $x^1(t) = [x_1^1(t), x_2^1(t), \dots, x_n^1(t)]^T$ and $y(t) = [y_1(t), y_2(t), \dots, y_n(t)]^T$ and the dimension of the context layer is m .

The input layer in this network can be modeled as follows:

$$u_i(l) = e_i(l), \quad i = 1, 2, \dots, n \quad (1)$$

where, l illustrates the input and the output layers in iteration l .

Then, the k th hidden layer in this network is considered as follows:

$$v_k(l) = \sum_{j=1}^n \omega_{kj}^1(l)x_j^c(l) + \sum_{i=1}^n \omega_{ki}^2(l)u_i(l) \quad k = 1, 2, \dots, N \quad (2)$$

where, $x_j^c(l)$ describes the signal that is forwarded from the k th context layer node, $\omega_{kj}^1(l)$ describes the i th and j th weights of the hidden layers sent from o th node.

Therefore, for the input layer l , the weight of the hidden layer k can be achieved by $\omega_{ki}^2(l)$.

Finally, the output value of the hidden layer which is injected to the context layer is obtained as follows:

$$W_k(l) = f_o(\bar{v}_k(l)) \quad (3)$$

where,

$$\bar{v}_k(l) = \frac{v_k(l)}{\max\{v_k(l)\}} \quad (4)$$

is the normalized value of the hidden layer.

The next layer is the context layer. In this layer, the output is equal to the following formula:

$$C_k(l) = \beta C_k(l - 1) + W_k(l - 1), \quad (5)$$

$k = 1, 2, \dots, N$

where, W_k points to the gain of self-connected feedback between 0 and 1. Razmjoooy and Khalilpour (2015).

Finally, the output layer at the network is as follows:

$$y_o(l) = \sum_{k=1}^N \omega_{ok}^3(l) W_k(l), \quad (6)$$

$o = 1, 2, \dots, n$

where, ω_{ok}^3 describes the weight of the connection from the k th layer into the o th layer.

For modifying the Elman neural network to increase the learning accuracy and better convergence, we utilized a new technique that is proposed by Ren et al. (2018) as follows:

```

Initializing the learning rate value  $\mu = \varepsilon$ 
In the  $l$ th iteration:
if  $l \leq 2$ :
 $\mu = \text{default value}$ ;
end if if  $t > = 3$  &&  $1.02e(l - 1) > e(l)$ :
 $\mu = c \frac{(1 + \frac{1}{t})^t}{\exp(1)}$ 
else
 $\mu = \text{default value}$ 
end
end
Weights updating;
evaluate  $e(t)$ ;
if the stop criteria are reached:
break;
else
continue
    
```

where, μ is learning rate, c is a constant, and t represents the current epoch. A comprehensive structure of Elman neural network is shown in Fig. 1.

The weights of the aforementioned modified Elman neural network is then optimized based on the suggested evolutionary algorithm.

2.2. Hybrid fluid search optimization based on world cup optimization algorithm and chaos theory

Nowadays, there are a lot of optimization problems around us that cannot be solved precisely, cannot be solved at all, or that it is not possible way to solve it within a reasonable time. This issue leads researches to look forward to an approach for solving these problems. A popular approach for solving the optimization algorithms is to use the Meta-heuristics.

Meta-heuristic is a type of optimization technique which has been inspired by different phenomena like genetic algorithm (Davis, 1991; Ghadimi, 2012; Mousavi and Soleymani, 2014), artificial bee colony (Karaboga and Aslan, 2018; Karaboga and Basturk, 2007; Razmjoooy and Khalilpour, 2015), particle swarm optimization algorithm (Razmjoooy and Ramezani, 0000; Ghadimi et al., 2013; Moallem and Razmjoooy, 2012), quantum-based invasive weed optimization algorithm (Razmjoooy and Ramezani, 2014), world cup optimization algorithm

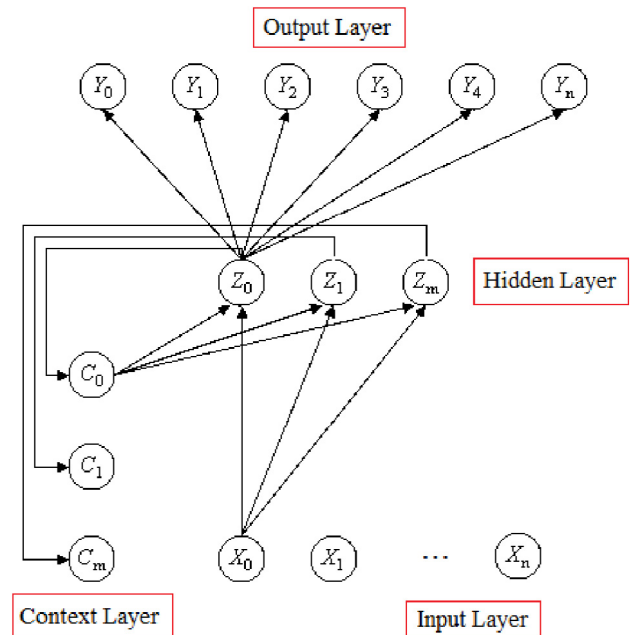

Fig. 1. The general form of the Elman neural networks.

(Razmjoooy et al., 2016; Bandaghi et al., 2016; Nejad et al., 2019; Razmjoooy and Shahrezaee, 0000; Razmjoooy et al., 2018; Shahrezaee, 2017), shark smell optimization algorithm (Ghadimi, 2015; Bagheri et al., 2018; Hussain et al., 2010; Rao et al., 2019), and fluid Search Optimization (Dong and Wang, 0000).

Applications of the meta-heuristic methods are extremely increasing in order to increase the number of complicated optimization problems (Razmjoooy et al., 2016; Razmjoooy and Ramezani, 2014; Ghadimi, 2015).

Fluid Search Optimization (FSO) algorithm is a new meta-heuristic method which is introduced in 2019. FSO algorithm is inspired by Bernoulli's principle in fluid mechanics.

Bernoulli's principle is about how the speed of a fluid relates to the pressure of the fluid so that by increasing the speed of the fluid, the potential energy and the pressure of the fluid have been decreased.

Bernoulli's equation is formulated in the following (Dong and Wang, 0000).

$$p + \frac{1}{2} \rho v^2 = p_0 \quad (7)$$

where, p is the pressure of a selected point on a streamline, p_0 describes the constant system pressure, v is the speed of the fluid flow at the point, and ρ describes the fluid density at all points in the fluid.

From the above equation, Dong and Wang proposed performs some simulations. They first re-formulated the Eq. (7) as follows (Dong and Wang, 0000).

$$v = \sqrt{\frac{2(p_0 - p)}{\rho}} \quad (8)$$

Then, they considered the new position of the solution as a recursive formula as follows,

$$x_{new} = x_{old} + v \quad (9)$$

Then, the pressure for the fluid infinitesimals is considered as the fitness function value, so that by increasing the pressure, the velocity of the fluid infinitesimal is decreased.

Optimization process in the fluid infinitesimal is related to the inverse process of the fluid flowing from the high pressure to the low pressure Involuntary.

The convergence of the fluid infinitesimals in the process of fluid flowing has been reached if the highest pressure point is found that can be considered to reach the optimum value. In the following, a brief explanation of the algorithm parameters is given.

2.3. Infinitesimal pressure

By considering the position of n number of infinitesimals as $X = [x_1, x_2, \dots, x_n]$, such that the fitness function is y , and the best and the worst values of the optimization are y_{best} and y_{worst} , respectively.

Infinitesimal pressure p_i is formulated as follows:

$$p_i = \frac{(y_{worst} - y_i)}{(y_{worst} - y_{best})} \quad (10)$$

where, p_i describes normalized value between 0 and 1 to prevent the impact of various objective functions on the algorithm. The initial value for p (p_0) is considered 1.

2.4. Infinitesimal density

The total number of neighbor infinitesimals in the cell of the present infinitesimal is called the infinitesimal density.

Here, the value of the other infinitesimals included in the D -dimension hypercube is m . So, the infinitesimals density is (Dong and Wang, 0000):

$$\rho = \frac{m}{l^D} \quad (11)$$

where, l is the cell side length.

2.5. The velocity of fluid infinitesimal

Since the value of the velocity can be achieved by Eq. (8), the direction of it is not definite. To consider the flow direction in the fluid infinitesimal, the vector summation of the pressure between the current and the other infinitesimals should be achieved.

To prevent the effects of the given weight due to the distance from the other infinitesimals, the distance is normalized.

Furthermore, the normalized value of the pressure is also added for more convergence of the algorithm which is given below.

$$\vec{p}_i = \sum_{\substack{j=1 \\ j \neq i}}^n \text{rand} \otimes p_j \frac{(X_j - X_i)}{|(X_j - X_i)|_2} + \text{rand} \otimes p_{best} \times 2 \times \frac{(X_{best} - X_i)}{|(X_{best} - X_i)|_2} \quad (12)$$

where, \vec{p}_i represent a vector value.

The new direction can be achieved by as follows:

$$D_n = \gamma \times D_l + \frac{\vec{p}_i}{|\vec{p}_i|_2} \quad (13)$$

where, D_n and D_l are the new direction and the last direction, respectively and γ is the inertial factor.

By testing the simple FSO algorithm in our work, it shows that it has some weaknesses for achieving the global optimization for the considered purpose. Therefore, a strong exploration-based method is required to improve the global optimization problem.

2.6. Modified FSO algorithm (MFSO)

World cup optimization (WCO) is a new meta-heuristic method that shows good performance in global optimization in different applications (Razmjoooy et al., 2016; Bandaghiiri et al., 2016; Nejad et al., 2019; Razmjoooy et al., 2018; Shahrezaee, 2017). In other words, WCO can be used as an auxiliary part for the FSO algorithm to improve its ability to escape from the local optimum.

To do so, the vector of the selective random parameters in the system, i.e. $C = [p_i, l, \gamma]$ are obtained by a combination of the WCO algorithm with FSO algorithm.

In other words, the input solution vector for the hybrid WOA is $n \times 3$, in which n describes the number of initial population:

$$[x_1^m, x_2^m, x_3^m] = [p_i, l, \gamma] \quad (14)$$

and

$$P_{teams} = \begin{bmatrix} x_{c1,1} & \cdots & x_{cM,1} \\ x_{c1,2} & \cdots & x_{cM,2} \\ x_{c1,3} & \cdots & x_{cM,3} \end{bmatrix} \quad (15)$$

where, x_i^m is the parameters of the FSO algorithm that should be optimally selected, P_{teams} is all continent population in the world, M describes the quantity for the continents, and $x_{i,j}$ is the i th team of the j th country.

Then, the rating of the teams in the WCO algorithm is obtained by the following formula:

$$\text{Rank} = \frac{(\beta \times \sigma + \bar{X})}{2} \quad (16)$$

$$\bar{X} = \frac{1}{n} \sum_{i=1}^n X_i \quad (17)$$

$$\sigma = \sqrt{\frac{1}{n-1} \sum_{i=1}^n (X_i - \bar{X})^2} \quad (18)$$

where, \bar{X} and σ describe the average and the standard deviation of the X , respectively, β describes the weight of the σ which is bounded between 0 and 1, and n describes the number of teams.

Afterward, *Play-Off* operator is applied to the algorithm as follows.

$$P = [X_{Best}, X_{Rand}] \quad (19)$$

where, P describes the next population of the algorithm by the size $N \times M$, X_{Rand} is a random value, and:

$$\frac{1}{2} \times p_r \times (Ub - Lb) < X_{Best} < \frac{1}{2} \times p_r \times (Ub + Lb) \quad (20)$$

where, Ub and Lb describe the higher and the lower bounds of the problem and p_r describes a coefficient between Lb and Ub . More information about WCO can be obtained from Razmjoooy et al. (2016).

Results of the application of the hybrid FSO and WCO algorithms showed good performance, but with one objection; this operation made this hybridization weaker from the point of convergence speed.

For increasing the convergence speed, logistic mapping function (as a chaos function) is utilized such that the iteration for the new populations is obtained based on chaos theory not completely randomly to increase the algorithm speed (Luo et al., 2019; Schymura and Kolossa, 2019). The logistic Mapping of the algorithm is obtained by the following:

$$L_i^{m+1} = \eta L_i^m (1 - L_i^m) \quad (21)$$

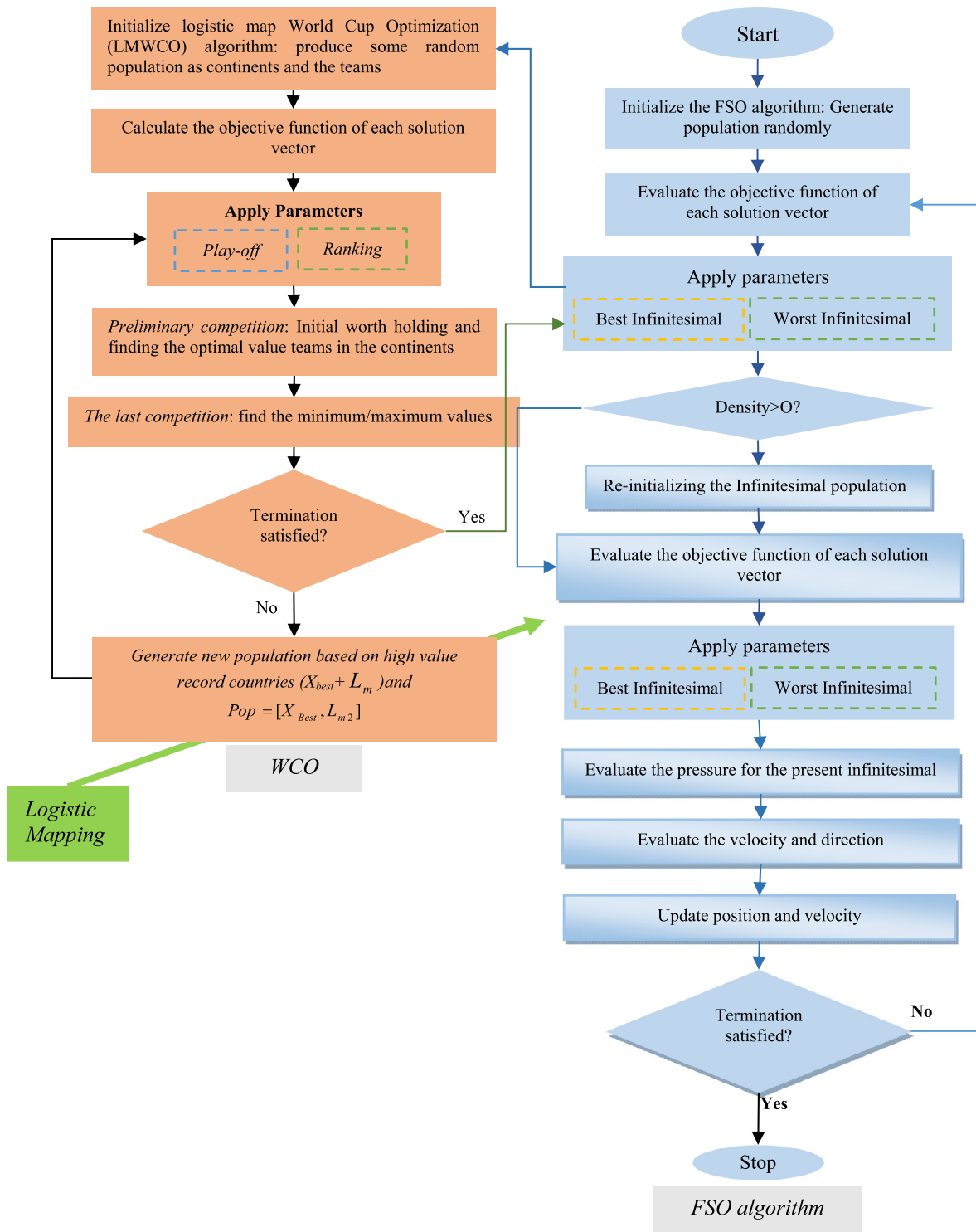

Fig. 2. Flowchart diagram of the proposed MFSO algorithm.

where, η describes the adjusting coefficient such that $\eta \in [0, 1] - \{0.25, 0.5, 0.75\}$ and $L_i^0 \in [0, 1]$ is the initial random number. The final algorithm is shown in Fig. 2.

3. Validation of the modified FSO algorithm

For efficiency analysis of the proposed modified FSO algorithm, four standard functions have been validated on the proposed algorithm (MFSO) and some different algorithms including genetic

algorithm (GA) (Holland, 1992), particle swarm optimization algorithm (PSO) (Bansal, 2019), world cup optimization algorithm (WCO) (Razmjoooy et al., 2016), and standard whale optimization algorithm (WOA) (Mirjalili and Lewis, 2016).

The simulations are applied by Matlab R2017b with a PC configuration of 2.50 GHz CPU and 16.0 GB RAM. Table 1 illustrates the benchmarks formulations that are used for the performance analysis.

Table 2 illustrates the mead deviation (MD) and the standard deviation (SD) values for the analyzed benchmarks.

Table 1
The utilized benchmarks for efficiency analysis.

Benchmark	Formula	Constraints	Dimension
Rastrigin	$f_1(x) = 10D + \sum_{i=1}^D (x_i^2 - 10 \cos(2\pi x_i))$	[-512, 512]	30–50
Rosenbrock	$f_2(x) = \sum_{i=1}^{D-1} (100(x_i - x_{i+1}) + (x_i - 1)^2)$	[-2.045, 2.045]	30–50
Ackley	$f_3(x) = -20 \exp\left(-0.2\sqrt{\frac{1}{D} \sum_{i=1}^D x_i^2}\right) - \exp\left(\frac{1}{D} \sum_{i=1}^D \cos(2\pi x_i)\right) + 20 + e$	[-10, 10]	30–50
Sphere	$f_4(x) = \sum_{i=1}^D x_i^2$	[-512, 512]	30–50

Table 2
The results of the efficiency analysis by considering 30-dimensions.

Benchmark		MFSO	GA (Holland, 1992)	PSO (Bansal, 2019)	WCO (Razmjooy et al., 2016)	WOA (Mirjalili and Lewis, 2016)
f_1	MD	0.00	70.61	74.24	2.19	2.58
	SD	0.00	1.66	8.96	4.35	2.14
f_2	MD	7.76	35.41	200.1	13.16	8.47
	SD	2.42	27.15	59.00	4.62	1.73
f_3	MD	0.00	3.19e-2	8.26	3.14e-3	3.17e-16
	SD	0.00	2.14e-2	1.19	1.12e-3	0.00
f_4	MD	0.00	1.15e-4	8.27e-4	6.19e-9	9.65e-11
	SD	0.00	3.14e-5	5.12e-4	3.28e-9	9.83e-17

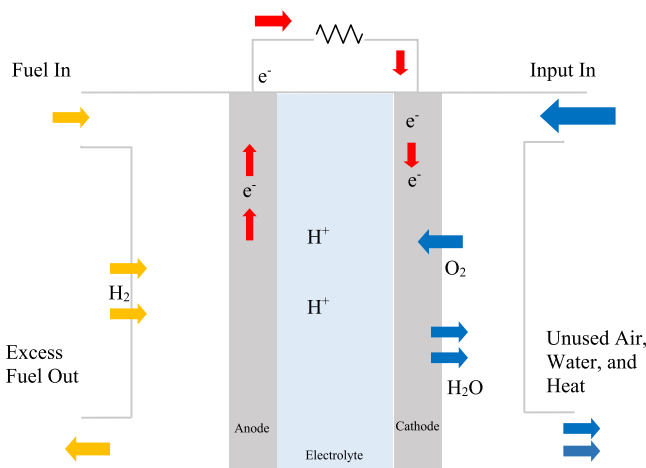

Fig. 3. The general model of a PEMFC.

From Table 2, it is clear that in all four cost functions, the Proposed ICWOA method gives promising results than the other methods, especially the original WOA algorithm.

4. Methodology validation by proton exchange membrane

As before said, the main application of the PEMFC is to utilize the hydrogen and the oxygen in the air for energy production.

In a PEMFC, a thin polymer membrane is employed as an electrolyte to provide a catalytic environment for the development of the necessary reactions on both sides of the platinum electrodes. Here, the electrolyte blocks electrons to pass through while allowing the protons.

In PEMFC, anode passes the Hydrogen through a catalyst (anode) for splitting the gas into electrons and hydrogen protons. Fig. 3 shows this process.

In the following, the dataset preparation for training the proposed network is described. For performance validating of the proposed method, it is performed on a PEMFC with the capacity of the 250 W in 4 different operational conditions including 1.5/1.5 bar with 343.15 K, 2.5/3 bar with 343.15 K, 1/1 bar with 343.15 K, and 3/5 bar with 353.15 K.

The experimental data for the performance analysis here is achieved by the model from Zhang and Wang (2013). 224 pairs of

inputs and outputs are selected from four operational conditions. 130 pairs (about 60%) of the data is utilized for training the proposed Elman neural network to find the optimum values, 44 pairs (10%) for validating, and 50 pairs (20%) for testing data.

In addition, a collection of sixty pairs by different operational conditions is obtained from Mo et al. (2006) to take the polarizing profiles and for testing the forecasting precision by the proposed ENN model.

Before training the data, they are normalized into the interval [0, 1] by the following equation:

$$\hat{z}_i = \frac{z_i - z_{i \min}}{z_{i \max} - z_{i \min}} \quad (22)$$

where, z_i describes the i th basic data, $z_{i \min}$ and $z_{i \max}$ are the lower and the upper limitations of the original information in the defined dataset, respectively.

5. Optimal modified ENN based on MFSO algorithm

In this section, the output voltage forecasting based on the modified ENN model is analyzed due to the voltage values in the present and the previous. The general form of the system is given in Fig. 4.

Error evaluation is performed by the following cost function which includes learning ENN for minimizing the sum of squared error between the voltage of neural network model (*Output*) and the experimental output voltage of the PEMFC as follows:

$$Error = \min \left\{ \sum_{i=1}^M (y - \hat{y})^2 \right\} \quad (23)$$

where, M describes the number of samples for the empirical information, and y and \hat{y} are the voltage of the neural network model and the output voltage of the empirical experiments of the PEMFC.

The function *Error* should be minimized by the proposed MFSO algorithm for achieving the center of the hidden neurons in the ENN.

As aforementioned, the ENN model configured is initialized based on the training dataset. Afterward, the proposed hybrid optimization algorithm can be obtained for optimizing the hidden nodes. The profile of the learning error for the identification of the PEMFC parameters based on the proposed method is shown in Fig. 5.

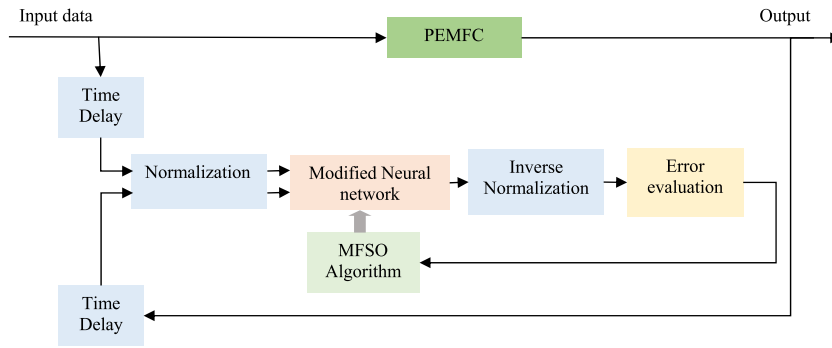

Fig. 4. The general form of the proposed system.

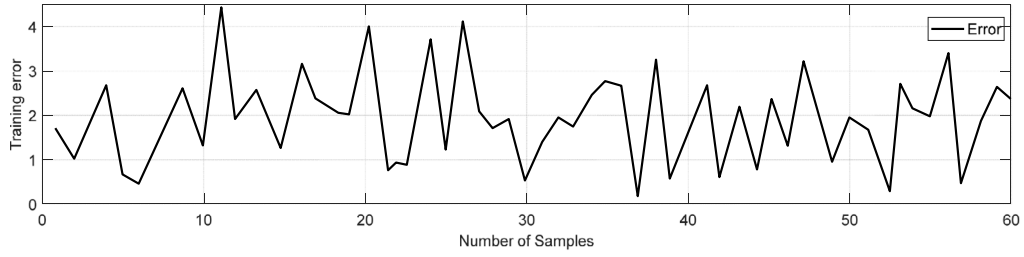

Fig. 5. The profile of the learning error for the sample data for PEMFC identification.

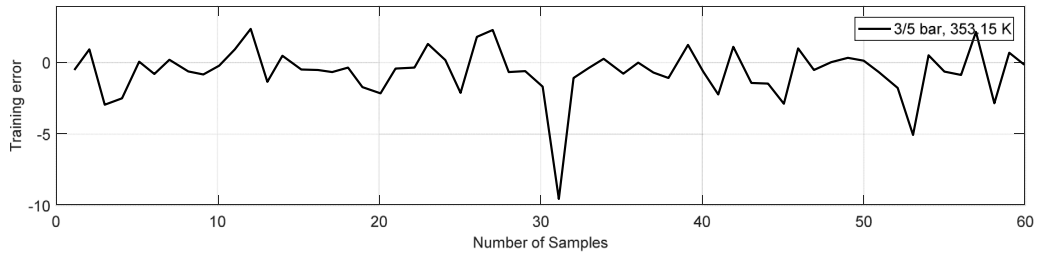

Fig. 6. The training error profile of the PEMFC identification for 3/5 bar, 353.15 K.

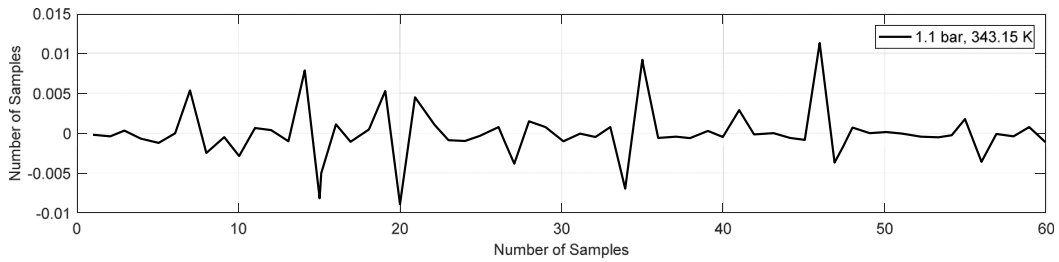

Fig. 7. The training error profile of the PEMFC identification for 1.1 bar, 343.15 K.

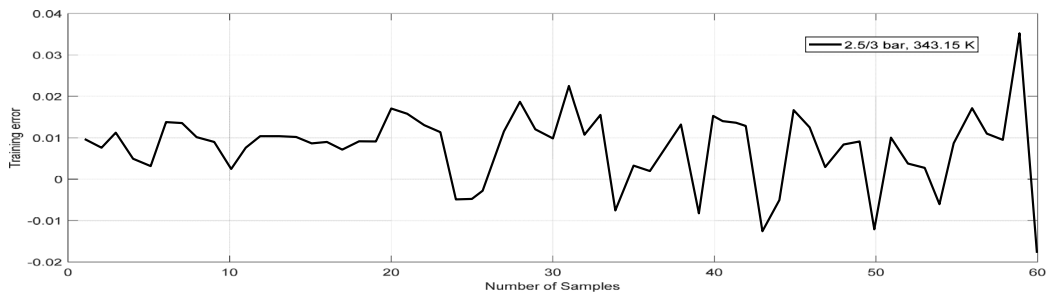

Fig. 8. The training error profile of the PEMFC identification for 2.5/3 bar, 343.15 K.

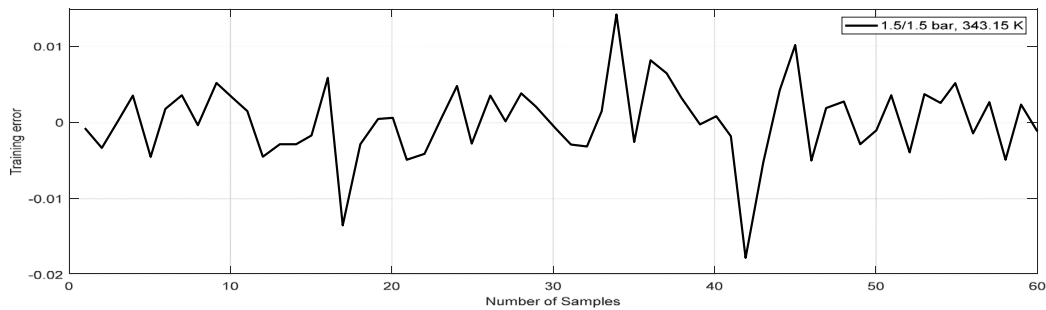
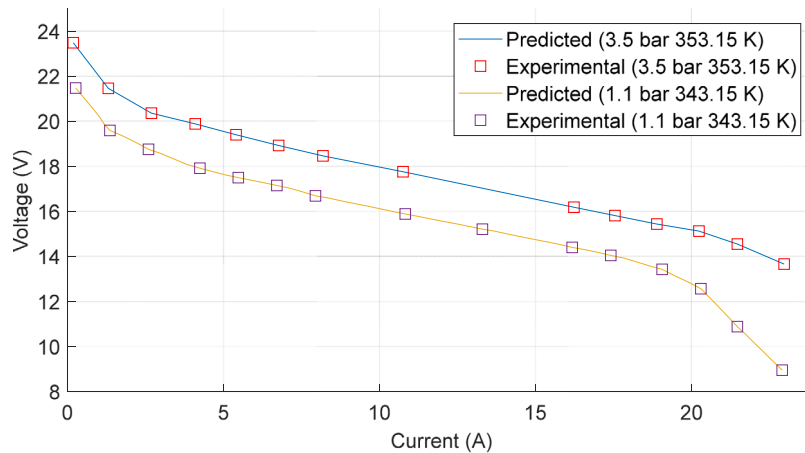
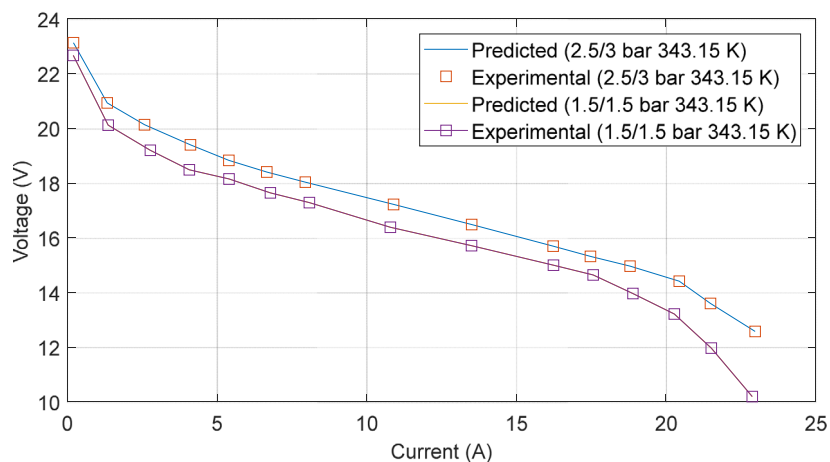

Fig. 9. The training error profile of the PEMFC identification for 1.1/1.5 bar, 343.15 K.



(A)



(B)

Fig. 10. The profile of the polarization for the experimental and predicted data for the operational conditions.

As before said, the learned model by the modified Elman neural network has also calculated through 4 general datasets. Figs. 6–9 show the results of the error profile for 4 datasets.

According to the above figures, it is clear that the error deviation of the empirical values and the forecasted values are low which makes the presented method a promising tool for the identification of the PEMFC parameters.

In addition, the profile of the polarization for four different operational conditions to prove the identification accuracy of the improved ENN model is shown in Fig. 10.

In Fig. 10, the forecasted voltage in terms of current based on the proposed neural network model is described. By considering the obtained results, the forecasted values and the experimental are almost similar; this shows the proposed method's high efficiency.

6. Conclusions

Fuel cells are a kind of renewable energy sources that uses electrochemical reactions for energy reduction. There are various

models of fuel cells that are divided based on the electrolyte applied. In this research, a proton exchange membrane fuel cell (PEMFC) is studied. The purpose of this paper is to investigate the PEMFC model to improve its efficiency. In this study, a new improved optimization algorithm based on hybridization of two new optimization algorithm, including fluid search optimization algorithm and world cup optimization algorithm is suggested. For increasing the convergence time, the logistic mapping function is applied to the algorithm. The efficiency of the presented optimization algorithm is compared with some different optimization algorithms. The designed algorithm is then applied to an improve Elman neural network for modeling the nonlinear PEMFC. Method's validation is performed on four different operational conditions. Final results show that the presented Elman network has a high performance in the modeling of the nonlinear PEMFC.

Acknowledgment

This paper was financially supported by Open Fund of State Key Laboratory of Power Grid Safety and Energy Conservation (China Electric Power Research Institute) (YDB51201901275).

References

- Abbaspour, A., Khalilnejad, A., Chen, Z., 2016. Robust adaptive neural network control for PEM fuel cell. *Int. J. Hydrogen Energy* 41, 20385–20395.
- Abedinia, O., Zareinejad, M., Doranegard, M.H., Fathi, G., Ghadimi, N., 2019. Optimal offering and bidding strategies of renewable energy based large consumer using a novel hybrid robust-stochastic approach. *J. Cleaner Prod.* 215, 878–889.
- Aghajani, G., Ghadimi, N., 2018. Multi-objective energy management in a micro-grid. *Energy Rep.* 4, 218–225.
- Ahadi, A., Ghadimi, N., Mirabbasi, D., 2015. An analytical methodology for assessment of smart monitoring impact on future electric power distribution system reliability. *Complexity* 21, 99–113.
- Bagal, H.A., Soltanabad, Y.N., Dadjuo, M., Wakil, K., Ghadimi, N., 2018. Risk-assessment of photovoltaic-wind-battery-grid based large industrial consumer using information gap decision theory. *Sol. Energy* 169, 343–352.
- Bagheri, M., Sultanbek, A., Abedinia, O., Naderi, M.S., Naderi, M.S., Ghadimi, N., 2018. Multi-objective Shark Smell Optimization for Solving the Reactive Power Dispatch Problem. In: 2018 IEEE International Conference on Environment and Electrical Engineering and 2018 IEEE Industrial and Commercial Power Systems Europe (EEEIC/I & CPS Europe), pp. 1–6.
- Bandaghiri, P.S., Moradi, N., Tehrani, S.S., 2016. Optimal tuning of PID controller parameters for speed control of DC motor based on world cup optimization algorithm. *Parameters* 1, 2.
- Bansal, J.C., 2019. Particle swarm optimization. In: *Evolutionary and Swarm Intelligence Algorithms*. ed: Springer, pp. 11–23.
- Bao, C., Bessler, W.G., 2015. Two-dimensional modeling of a polymer electrolyte membrane fuel cell with long flow channel. Part II. Physics-based electrochemical impedance analysis. *J. Power Sources* 278, 675–682.
- Caux, S., Hankache, W., Fadel, M., Hissel, D., 2010. PEM fuel cell model suitable for energy optimization purposes. *Energy Convers. Manage.* 51, 320–328.
- Davis, L., 1991. *Handbook of genetic algorithms*.
- Dong, R., Wang, S., 0000. New optimization algorithm inspired by fluid mechanics to combined economic.
- El-Hay, E., El-Hameed, M., El-Fergany, A., 2019. Optimized parameters of SOFC for steady state and transient simulations using interior search algorithm. *Energy* 166, 451–461.
- Eslami, Mahdiyeh, et al., 2019. A new formulation to reduce the number of variables and constraints to expedite SCUC in bulky power systems. *Proc. Natl. Acad. Sci. India A* 89 (2), 311–321.
- Ghadimi, N., 2012. Genetically tuning of lead-lag controller in order to control of fuel cell voltage. *Sci. Res. Essays* 7, 3695–3701.
- Ghadimi, Noradin, 2015. A new hybrid algorithm based on optimal fuzzy controller in multimachine power system. *Complexity* 21 (1), 78–93.
- Ghadimi, N., Afkousi-Paqaleh, M., Nouri, A., 2013. PSO based fuzzy stochastic long-term model for deployment of distributed energy resources in distribution systems with several objectives. *IEEE Syst. J.* 7, 786–796.
- Ghadimi, N., Akbarimajid, A., Shayeghi, H., Abedinia, O., 2018. Two stage forecast engine with feature selection technique and improved meta-heuristic algorithm for electricity load forecasting. *Energy* 161, 130–142.
- Hatti, M., Tioursi, M., 2009. Dynamic neural network controller model of PEM fuel cell system. *Int. J. Hydrogen Energy* 34, 5015–5021.
- Holland, J.H., 1992. *Genetic algorithms*. *Sci. Am.* 267, 66–73.
- Hussain, B., Sharkh, S., Hussain, S., 2010. Impact studies of distributed generation on power quality and protection setup of an existing distribution network, in *Power Electronics Electrical Drives Automation and Motion (SPEEDAM)*, 2010 International Symposium on, pp. 1243–1246.
- Ijaodola, O., El-Hassan, Z., Ogungbemi, E., Khatib, F., Wilberforce, T., Thompson, J., et al., 2019. Energy efficiency improvements by investigating the water flooding management on proton exchange membrane fuel cell (PEMFC). *Energy* 179, 246–267.
- Karaboga, D., Aslan, S., 2018. Discovery of conserved regions in DNA sequences by Artificial Bee Colony (ABC) algorithm based methods. *Nat. Comput.* 1–18.
- Karaboga, D., Basturk, B., 2007. A powerful and efficient algorithm for numerical function optimization: artificial bee colony (ABC) algorithm. *J. Global Optim.* 39, 459–471.
- Khodaei, H., Hajiali, M., Darvishan, A., Sepehr, M., Ghadimi, N., 2018. Fuzzy-based heat and power hub models for cost-emission operation of an industrial consumer using compromise programming. *Appl. Therm. Eng.* 137, 395–405.
- Kumar, P.A., Geetha, M., Chandran, K., Sanjeevikumar, P., 2018. PEM fuel cell system identification and control. In: *Advances in Smart Grid and Renewable Energy*. ed: Springer, pp. 449–457.
- Liu, Yang, Wang, Wei, Ghadimi, Noradin, 2017. Electricity load forecasting by an improved forecast engine for building level consumers. *Energy* 139, 18–30.
- Luo, Y., Yu, J., Lai, W., Liu, L., 2019. A novel chaotic image encryption algorithm based on improved baker map and logistic map. *Multimedia Tools Appl.* 1–21.
- Mirjalili, S., Lewis, A., 2016. The whale optimization algorithm. *Adv. Eng. Softw.* 95, 51–67.
- Mirzapour, F., Lakzaei, M., Varamini, G., Teimourian, M., Ghadimi, N., 2019. A new prediction model of battery and wind-solar output in hybrid power system. *J. Ambient Intell. Humaniz. Comput.* 10, 77–87.
- Mo, Z.J., Zhu, X.J., Wei, L.Y., Cao, G.Y., 2006. Parameter optimization for a PEMFC model with a hybrid genetic algorithm. *Int. J. Energy Res.* 30, 585–597.
- Moallem, P., Razzmjoo, N., 2012. Optimal threshold computing in automatic image thresholding using adaptive particle swarm optimization. *J. Appl. Res. Technol.* 10, 703–712.
- Mousavi, B.S., Soleymani, F., 2014. Semantic image classification by genetic algorithm using optimised fuzzy system based on Zernike moments. *Signal Image Video Process.* 8, 831–842.
- Namadchian, A., Ramezani, M., Razzmjoo, N., 2016. A new meta-heuristic algorithm for optimization based on variance reduction of gaussian distribution. *Majlesi J. Electr. Eng.* 10, 49.
- Nejad, Hadi Chahkandi, et al., 2019. Reliability based optimal allocation of distributed generations in transmission systems under demand response program. *Electr. Power Syst. Res.* 176, 105952.
- Papadopoulos, P.N., Kandyla, M., Kourtza, P., Papadopoulos, T.A., Papagianis, G.K., 2014. Parametric analysis of the steady state and dynamic performance of proton exchange membrane fuel cell models. *Renew. Energy* 71, 23–31.
- Rao, Y., Shao, Z., Ahangarnejad, A.H., Gholamalizadeh, E., Sobhani, B., 2019. Shark Smell Optimizer applied to identify the optimal parameters of the proton exchange membrane fuel cell model. *Energy Convers. Manage.* 182, 1–8.
- Razzmjoo, N., Khalilpour, M., 2015. A Robust Controller For Power System Stabilizer By Using Artificial Bee Colony Algorithm.
- Razzmjoo, N., Khalilpour, M., Ramezani, M., 2016. A new meta-heuristic optimization algorithm inspired by FIFA world cup competitions: Theory and its application in PID designing for AVR system. *J. Control Autom. Electr. Syst.* 27, 419–440.
- Razzmjoo, N., Ramezani, M., 0000. Training Wavelet Neural Networks Using Hybrid Particle Swarm Optimization and Gravitational Search Algorithm for System Identification.
- Razzmjoo, N., Ramezani, M., 2014. An improved quantum evolutionary algorithm based on invasive weed optimization. *Indian J. Sci. Res.* 4, 413–422.
- Razzmjoo, N., Shahrezaee, M., 0000. Solving Ordinary Differential Equations using World Cup Optimization Algorithm.
- Razzmjoo, N., Sheykahmad, F.R., Ghadimi, N., 2018. A hybrid neural network-world cup optimization algorithm for melanoma detection. *Open Med.* 13, 9–16.
- Ren, G., Cao, Y., Wen, S., Huang, T., Zeng, Z., 2018. A modified elman neural network with a new learning rate scheme. *Neurocomputing* 286, 11–18.
- Rezazadeh, A., Sedighzadeh, M., Karimi, M., 2010. Proton exchange membrane fuel cell controlling a predictive control based on neuralnetwork. *Int. J. Comput. Electr. Eng.* 2, 81.
- Saeedi, M., Moradi, M., Hosseini, M., Emamifar, A., Ghadimi, N., 2019. Robust optimization based optimal chiller loading under cooling demand uncertainty. *Appl. Therm. Eng.* 148, 1081–1091.
- Schymura, C., Kolossa, D., 2019. Learning Dynamic Stream Weights for Linear Dynamical Systems Using Natural Evolution Strategies, in *ICASSP 2019-2019 IEEE International Conference on Acoustics, Speech and Signal Processing (ICASSP)*, pp. 7893–7897.
- Shahrezaee, M., 2017. Image segmentation based on world cup optimization algorithm. *Majlesi J. Electr. Eng.* 11.

- Solsona, M., Kunusch, C., Ocampo-Martinez, C., 2017. Control-oriented model of a membrane humidifier for fuel cell applications. *Energy Convers. Manage.* 137, 121–129.
- Springer, T.E., Zawodzinski, T., Gottesfeld, S., 1991. Polymer electrolyte fuel cell model. *J. Electrochem. Soc.* 138, 2334–2342.
- Steiner, N.Y., Hissel, D., Moçotéguy, P., Candusso, D., 2011. Diagnosis of polymer electrolyte fuel cells failure modes (flooding & drying out) by neural networks modeling. *Int. J. Hydrog. Energy* 36, 3067–3075.
- Sun, Z., Wang, N., Bi, Y., Srinivasan, D., 2015. Parameter identification of PEMFC model based on hybrid adaptive differential evolution algorithm. *Energy* 90, 1334–1341.
- Tao, S., Guang-yi, C., Xin-jian, Z., 2005. Nonlinear modeling of PEMFC based on neural networks identification. *J. Zhejiang Univ.-Sci. A* 6, 365–370.
- Wu, X.-J., Huang, Q., Zhu, X.-J., 2011. Power decoupling control of a solid oxide fuel cell and micro gas turbine hybrid power system. *J. Power Sources* 196, 1295–1302.
- Zhang, L., Wang, N., 2013. An adaptive RNA genetic algorithm for modeling of proton exchange membrane fuel cells. *Int. J. Hydrogen Energy* 38, 219–228.