

Tungadio, Diambomba Hyacinthe; Sun, Yanxia

Article

Load frequency controllers considering renewable energy integration in power system

Energy Reports

Provided in Cooperation with:

Elsevier

Suggested Citation: Tungadio, Diambomba Hyacinthe; Sun, Yanxia (2019) : Load frequency controllers considering renewable energy integration in power system, Energy Reports, ISSN 2352-4847, Elsevier, Amsterdam, Vol. 5, pp. 436-453, <https://doi.org/10.1016/j.egy.2019.04.003>

This Version is available at:

<https://hdl.handle.net/10419/243599>

Standard-Nutzungsbedingungen:

Die Dokumente auf EconStor dürfen zu eigenen wissenschaftlichen Zwecken und zum Privatgebrauch gespeichert und kopiert werden.

Sie dürfen die Dokumente nicht für öffentliche oder kommerzielle Zwecke vervielfältigen, öffentlich ausstellen, öffentlich zugänglich machen, vertreiben oder anderweitig nutzen.

Sofern die Verfasser die Dokumente unter Open-Content-Lizenzen (insbesondere CC-Lizenzen) zur Verfügung gestellt haben sollten, gelten abweichend von diesen Nutzungsbedingungen die in der dort genannten Lizenz gewährten Nutzungsrechte.

Terms of use:

Documents in EconStor may be saved and copied for your personal and scholarly purposes.

You are not to copy documents for public or commercial purposes, to exhibit the documents publicly, to make them publicly available on the internet, or to distribute or otherwise use the documents in public.

If the documents have been made available under an Open Content Licence (especially Creative Commons Licences), you may exercise further usage rights as specified in the indicated licence.



<https://creativecommons.org/licenses/by-nc-nd/4.0/>



Review article

Load frequency controllers considering renewable energy integration in power system



Diambomba Hyacinthe Tungadio*, Yanxia Sun

Department of Electrical and Electronic Engineering Science, University of Johannesburg, Auckland Park Kingsway Campus, Johannesburg 2006, South Africa

HIGHLIGHTS

- Load frequency controllers.
- Artificial intelligence controllers.
- Traditional control strategies.
- Modern power system configuration.

ARTICLE INFO

Article history:

Received 10 September 2018
 Received in revised form 2 April 2019
 Accepted 3 April 2019
 Available online xxxx

Keywords:

Load frequency control
 Power system
 Controllers
 Artificial intelligence

ABSTRACT

Load frequency control or automatic generation control is one of the main operations that take place daily when considering a modern power system or not. The objectives of load frequency control are to maintain power balance between interconnected areas and to control the power flow in the tie-lines. Electric power cannot be stocked in large quantity that why its production must be equal to the consumption in each time. This equation constituted the key for a good management of any power system and introduces the need of more controllers when taking into account the integration of renewable energy sources into the traditional power system. More controllers are presented in the literature and the presents work proposes a review of those called traditional and those who combined the traditional controller and artificial intelligence algorithms.

© 2019 The Authors. Published by Elsevier Ltd. This is an open access article under the CC BY-NC-ND license (<http://creativecommons.org/licenses/by-nc-nd/4.0/>).

Contents

1. Introduction.....	438
2. Traditional controllers.....	438
3. Hybrid models	439
3.1. Fuzzy logic model.....	440
3.2. LFC based particle swarm optimisation algorithm.....	441
3.3. LFC based genetic algorithm	441
3.4. LFC other models based on artificial intelligence algorithm.....	441
3.5. LFC based on decentralised techniques	444
3.6. LFC based on dual mode approach.....	444
3.7. LFC based FACTS and storage system	444
3.8. LFC based on robust model	446
4. Model predictive control strategy	447
4.1. Predictive control strategies.....	447
4.2. Distributed MPC.....	448
4.3. Robust MPC	448
5. Summary and future work.....	449
5.1. Summary.....	449

* Corresponding author.

E-mail addresses: tutudiambomba@yahoo.fr (D.H. Tungadio), ysun@uj.ac.za (Y. Sun).

5.2. Future scope	449
Acknowledgment	449
References	450

1. Introduction

Power system is a dynamic system where interacts active elements connected together via power lines. Its goal is to deliver power to a variable load or ensemble of consumers which is one of its critical parts (Jaleeli et al., 1992; Zhang and Fang, 2017; Tungadio, 2018; Tungadio et al., 2017; Essiet et al., 2019). Changes in loads affect mainly the frequency of the power network, while the reactive power related to voltage magnitude is less sensitive to the changes of frequency, that why active and reactive powers are controlled separately. Automatic generation control (AGC) or load frequency control (LFC) is one of the main operations for a good management of any electrical systems. The aim of LFC is to monitor the variation of active power by providing the signals for control of the frequency regulator and active power output of different generating units within the limits prescribed control area in response to the changes in system frequency and tie-line loading, and it helps to maintain the scheduled system frequency and establish interchange with other areas (Zhang and Fang, 2017; Tungadio, 2018). Due to dynamic characteristics of the load add its continuous and random changes during the operation of the power system, most of the time the quality of the power supplied to the consumers is affected (Essiet et al., 2019; Tungadio et al., 2018a). Therefore, in the day-to-day management of the electrical system the control aspect is necessary to maintain a continuous balance between power generated and power consumed or load demand.

The problem becomes more complex when dealing with an interconnected system (Essiet et al., 2019; Tungadio et al., 2018a). In fact, the reliability and continuity of service of two or more isolated power grids (microgrids) can be achieved by their interconnection through tie-lines. An interconnected power system can be considered as being divided into control areas; all generating units are assumed to form a coherent system (Doolla et al., 2011; Kang and Liao, 2010; Mehra et al., 2015; Olivares et al., 2014; Parmar et al., 2012; Hung et al., 2014). In the steady state power system demands of areas are satisfied at the nominal frequency. The change of active power in one area is sustained by the increase in generation in all areas associated with a change in the tie-lines power flow and a reduction in frequency (Majumder et al., 2010; Yuen et al., 2011; Dzobo and Sun, 2019; Zhao and Dorfler, 2015). As the power load demand varies randomly, all areas frequency and the tie-lines power interchange also vary (Nikmehr and Ravadanegh, 2016; Kundur, 1994). The objectives of LFC are to minimize the deviations in frequency and tie-line power flows which are taken as the control variables and to ensure that the frequency variation is returned to zero. A basic control system strategy for the normal mode is to operate in such a way that it keeps the frequency at approximately nominal value, maintaining the tie-line power flow out of each area at the planned value. Each area should absorb its own load changes (Zhang and Fang, 2017; Tungadio, 2018; Tungadio et al., 2017, 2018a). That is why the primary purpose of operating the LFC is to keep the frequency changes during the load changes uniform.

Furthermore, the control model must be sensitive against changes in the area (Tungadio, 2018; Tungadio et al., 2017). Fig. 2 shows an interconnection of three power systems (three areas) via tie-lines. This configuration increases the reliability and the continuity of the new constituted system. In fact, the

reliability and continuity of service of two or more isolated microgrids can be achieved by their interconnection through tie-lines. An interconnected power system can be considered as being divided into control areas; all generating units are assumed to form a coherent system (Zhao and Dorfler, 2015; Nikmehr and Ravadanegh, 2016). In the steady state power system demands of areas are satisfied at the nominal frequency. The change of active power in one area is sustained by the increase in generation in all areas associated with a change in the tie-lines power flow and a reduction in frequency (Tungadio et al., 2017; Kundur, 1994; Goyal and Ghosh, 2016; Tungadio and Bansal, 2017; Fu et al., 2015). Published research on controllers used for frequency control in power grids is abundant and new models continue to be proposed in the literature (Tungadio, 2018). Some authors have exploited the aspect the control frequency based on the different energy sources used in new power system, while the others propose models based on configuration of power system models and control techniques and strategies based on conventional as well as distribution generation using traditional controllers or controllers models based on artificial intelligence algorithms.

Considering the discussion above this paper identifies and reviews the merits and demerits of momentum gaining load frequency controllers such as traditional controllers model, hybrid control strategies and predictive controller strategy to keep the frequency as scheduled. The emphasis is also set to identify the recent issues and challenges faced in the load frequency controllers; integration of the renewable energy sources, power quality issues including frequency and voltage profile of the system to maintain to its nominal value in order to deliver quality electric power to the consumers and profitable to the electric utilities. Some indicators as controller settling time, and the maximum overshoot (fast responses and good stability) are taken as a good indicator of a controller. The rest of the paper is organized as follows. In Section 2 traditional controllers such as proportional integral or proportional integral derivative review and hybrid controllers in Section 3. Section 4 presents the detailed literature review regarding the predictive control model. Finally, the conclusion is summarized in Section 5.

2. Traditional controllers

Most of the research in the field of the control of microgrids is devoted to the use of conventional controllers such as integral (I), proportional integral (PI) or proportional integral-derivative (PID). The main reason is 90% or more of control loops in industry are traditional models. Fig. 1 gives the standard control model, where the variables (R), (e), (u), (Y) represent successively the difference between the desired input value, the tracking error, the input signal, and the actual output. To obtain a desired response, PID controller model is the most used when considering the conventional controllers models. This situation is based on a trying process. The following steps are generally used:

- Obtain an open-loop response and determine what needs to be improved;
- Add a proportional control to improve the rise time;
- Add a derivative control to improve the overshoot;
- Add an integral control to eliminate the steady-state error;
- Adjust each of k_p , k_i , and k_d , until you obtain a desired overall response.

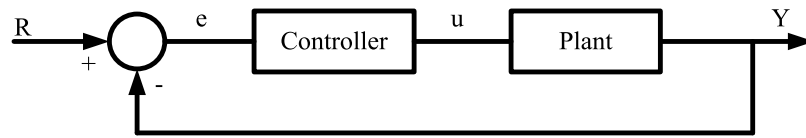

Fig. 1. Conventional Controller.

where each k_i represents the gain of the controller.

A new PID load frequency controller design method in frequency domain through direct synthesis approach was proposed in Anwar and Pan (2015). The method yields linear algebraic equations, solution of which gives the controller parameters. Saxena and Hote (2016) have proposed a decentralised PID-LFC for perturbed multi-area power systems. The beauty of the proposed approach was that the fixed PID controller is taking care of uncertainty in the each control are. Delay distribution dependent LFC of power systems with probabilistic interval delays was proposed in Peng and Zhang (2016). An algorithm was provided to obtain the gain of PI-based LFC and the allowable upper bound of the communication delay simultaneously while preserving the desired performance. The authors (Debbarma et al., 2014) have proposed an AGC using two degree of freedom fractional order PID controller. The work also explored the effectiveness of the firefly algorithm based optimisation technique in finding the optimal parameters of the controller and selection of R parameter. Optimal tuning of 3 degree of freedom PID controller for hybrid distributed power system using dragonfly algorithm (DA) was proposed in Guha et al. (2018). The efficacy of proposed DA over different reported algorithms was established in terms of convergence rate, minimum fitness value and dynamic performance of the system. Design of a fractional order PID controller for an AVR using particle swarm optimisation (PSO) algorithm was proposed in Zamani et al. (2009). A novel cost function was defined to facilitate the control strategy over both the time-domain and the frequency domain specifications.

The authors (Nandar, 2013) have proposed a robust PI control of smart controllable load for frequency stabilisation of microgrid power system. To guarantee the robustness of the proposed PI controller, an inverse additive perturbation is formulated as an optimisation problem and a genetic algorithm (GA) was employed to tune and optimise the proposed PI control parameters. Fractional order PID controller design for LFC in electric power systems using imperialist competitive algorithm was proposed in Taher et al. (2014). This controller had five parameters to be tuned; thus, it provided two more degrees of freedom in comparison with the conventional PID. Researchers (Hanwate and Hote, 2018) have proposed an optimal PID design for LFC using QRAWCP approach. In addition to the nominal situation, robustness of this controller was also tested on the same systems with respect to parametric uncertainty, external disturbances, tested on the same systems with respect to parametric uncertainty, external disturbances. Fig. 2 shows the interconnected power system via tie-lines, this gives the configuration of the new power system.

Fuzzy Gain Scheduling of PID controllers were presented in Zhao et al. (1993). Fuzzy rules and reasoning are utilised on-line to determine the controller parameters based on the error signal and its first difference. Improved grey wolf optimisation technique for fuzzy aided PID controller design for power system frequency control was proposed in Sahoo and Panda (2018). Proposed IGWO was initially evaluated using some standard test functions. The authors (Ali and Abd-Elazim, 2013) have presented a BFOA based design of PID controller for two areas LFC with nonlinearities. The effectiveness of the proposed BFOA was validated over different operating conditions, and system parameters

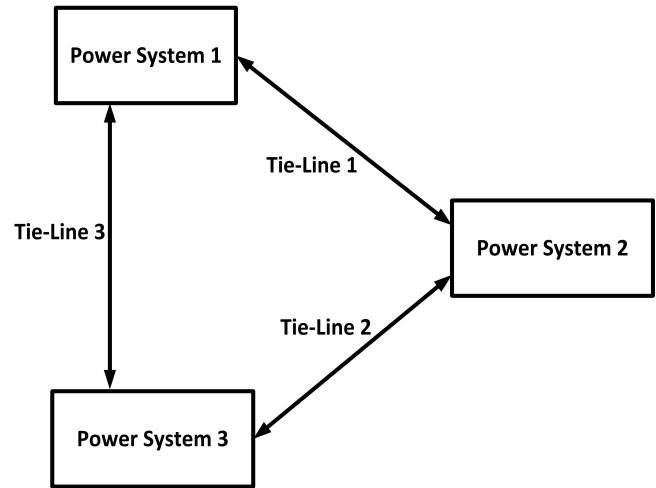

Fig. 2. Power system interconnected via tie-lines.

variations. The research in Doolla et al. (2011) has presented a LFC of an isolated small hydro power plant using multi-pipe scheme. The proposed scheme reduces the size of the dump load to 50%, as 50% input power of the hydro plant is controlled by an on/off control. A generalised transfer function model for the system is developed with on/off control logic, and the parameters were optimised using the integral time absolute error technique. The design of a robust distributed control for interconnected microgrids was proposed in Hossain et al. (2015). Time-domain analyses were carried out considering different scenarios and large disturbances. Zamani et al. (2016b) have presented a design of a fractional order PID controller using gases Brownian motion optimisation (GBMO) algorithm for LFC with governor saturation consideration. The performance of the proposed controller in time domain and its robustness was verified according to comparison with other controllers like GBMO based fuzzy controller and PI controller that used for LFC system in confronting with model parameters variations. The research in Jagatheesam et al. (2015) introduced a robust PI control of smart controllable load for frequency stabilisation of microgrid power system. To guarantee the robustness of the proposed PI controller, an inverse additive perturbation was formulated as an optimisation problem. A new PID controller design for AGC of hydro power systems was presented in Khodabakhshian and Hooshmand (2010). The open-loop frequency response curve was tangent to a specified ellipse and this makes the method to be efficient for controlling the overshoot, the stability and the dynamics of the system.

3. Hybrid models

The integration of the renewable energy resources into the power system creates new issues because most of them are whether dependent. Power systems need advanced control methods for its daily management. In the control area, the new tendency is the combination of the artificial intelligence algorithms particle swarm optimisation algorithm (PSO), fuzzy logic (FL), genetic algorithm (GA), etc. with the conventional controller to

solve the frequency or active power flow control issue in power system. Some models based on FL approach are available in the literature.

3.1. Fuzzy logic model

Li et al. (2008) have proposed frequency control in the microgrid power system combined with an electrolyser system and fuzzy PI controller. The proposed control can be regarded as a means of power quality control to improve frequency fluctuations. An optimal FL-based PID and self-tuning fuzzy PID controller was presented in Pothiya and Ngamroo (2008) and Yesil et al. (2004). Vigneysh and Kumarappan (2016) have presented the control of PV-solid oxide fuel cell-battery energy storage (BES) based microgrid using an FL controller. FL based generalised droop control (GDC) for simultaneous voltage and frequency regulation in an AC microgrid was discussed in Ahmadi et al. (2015). A fuzzy technique was utilised to tune the GDC and secondary control parameters. A fuzzy gain scheduling controllers for automatic generation of two area interconnected electrical power systems was presented in Arya and Kumar (2016). A novel hybrid local unimodal sampling teaching learning based optimised (TLBO) fuzzy-PID controller for LFC of multi-area power system was presented in Fattahi et al. (2016). Root locus analysis of are presentative microgrid with three inverters has been undertaken to confirm that stable solutions are feasible. Novel control scheme based on droop characteristics for LFC of microgrids working in autonomous mode was presented by Khederzadeh and Maleki in Khederzadeh and Maleki (2013). The proposed droop speed control helps to balance the supply–demand in the autonomous mode by charging–discharging the batteries and increasing–decreasing the power outputs of the micro-sources. Sahu et al. (2016b) have presented a novel hybrid LUS–TLBO optimised Fuzzy-PID controller for load frequency control of multi-source power system. Again the robustness of the proposed controller for power system with AC tie-line only is studied under parametric variation conditions by varying all the parameters from -50% to 50% of their nominal values in steps of 25% . Liu et al. (2016a) have presented a DMPC for LFC with dynamic fuzzy valve position modelling for hydro-thermal power system. In the proposed scheme, the limit position of the governor valve is modelled by a fuzzy model and the local predictive controllers are incorporated into the non-linear control system. A fuzzy adaptive model predictive approach for LFC of an isolated microgrid was presented in Kayalvizhi and Kumar (2017). A generalised state space model of a typical isolated microgrid having controllable and uncontrollable generating power sources were derived, and the same has been utilised to predict the future output and control inputs for the microgrid frequency control. Fig. 3 gives the tie-lines models for two power system interconnected.

An adaptive polar FL based LF controller was proposed in Chaturvedi et al. (2015). The authors introduced a polar FL to overcome the issue of the computation time and memory requirements. Performance of the simple PFC and adaptive PFC using GAF is compared with fuzzy and conventional PI controllers on a three area system. Adaptive fuzzy logic LFC of multi-area power system was proposed in Yousef (2015). It was proved that the proposed controller ensures the boundedness of all variables of the closed-loop system and the tracking error. Yousef et al. (2014) have proposed a LFC of a multi-area power system based on an adaptive FL approach. The FL system approximation capabilities were exploited to develop suitable adaptive control law and parameter update algorithms for unknown interconnected LFC areas. Research presented in Obaid et al. (2016) presents the FL based fine-tuning approach for robust LFC control in a multi-area power system. The design procedure of a robust FL-based fine tuning controller was substantially nourished

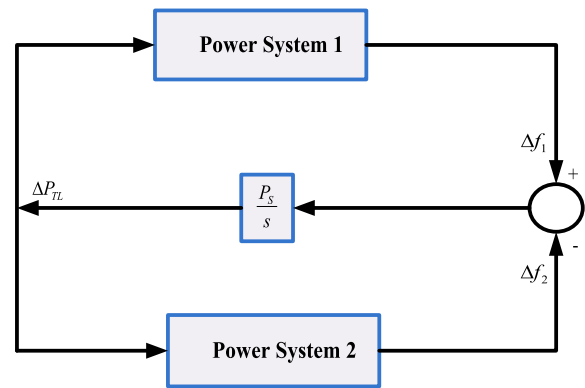

Fig. 3. Tie-lines models (Tungadio et al., 2017).

by expert knowledge regarding the system performance. Fuzzy hierarchical approach-based optimal frequency control in the Great Britain power system was proposed in Kocaarslan and Cam (2005). The proposed model allowed the fuzzy to supplement the conventional control rather than replace it.

FL controller in interconnected electrical power systems for LFC was presented in Sabahi et al. (2016). The model presented has shown the effectiveness and the suitability for damping out oscillations resulted from load perturbations. Cam and Kocaarslan (2005) have proposed a designing of an adaptive type-2 FL system LFC for a nonlinear time-delay power system. The proposed model was the combination of type-2 FL system and a non-conventional feedback controller. Abazari et al. (2018) have proposed a LFC in two area power systems using fuzzy logic controller. The presented model has improved the dynamics of the system studied. The authors in Ahmadi et al. (2015) have proposed an optimal FL based frequency control strategy in a high wind penetrated power system. The proposed FL controller was blessed with robustness, simplicity, and reliability in order to ameliorate the frequency deviation. A FL based droop control for simultaneous voltage and frequency regulation in an AC microgrid was proposed in Vigneysh and Kumarappan (2016). It was shown that the proposed FL controller exhibits high performance and desirable response for different scenarios of change in load. Researchers (Thao and Uchida, 2017) have proposed an autonomous operation and control of photovoltaic-solid oxide fuel cell-battery energy storage based microgrid using FL controller. The microgrid voltage and frequency was effectively maintained within the limits by the proposed FLC.

A two-level control strategy with FL for large-scale photovoltaic farms to support grid frequency regulation was proposed in Kocaarslan and Cam (2005). The individual reference value for each local controller was determined. FL controller in interconnected electrical power systems for LFC was presented in Sudha and Santhi (2012). Mode simulations of the power system show that the proposed FGPI controller was effective. LFC of an interconnected reheat thermal system using Type-2 fuzzy system including superconducting magnetic energy storage (SMES) units was proposed in Ahmadi et al. (2015). The proposed method was tested on a two area power system to illustrate its robustness performance with various area load changes. A FL based droop control for simultaneous voltage and frequency regulation in an AC microgrid was proposed in Yousef (2015). It was shown that the proposed FL controller exhibits high performance and desirable response for different scenarios of change in load. Adaptive FL-LFC of multi-area power system was proposed in Cam and Kocaarslan (2005). It was proved that the proposed controller ensures the boundedness of all variables of the closed loop system

and the tracking error. LFC in two area power systems using FL controller was proposed in [Cam \(2007\)](#). It has been shown that the proposed FGPI controller can generate the best dynamic response following a step load change.

Application of FL for LFC of hydroelectrical power plants was presented in [Pothiya and Ngamroo \(2008\)](#). The comparison study indicated that the proposed FGPI controller has better performance than the conventional PI controller. The authors ([Shayaghi et al., 2008](#)) have proposed an optimal FL based PID controller for LFC including SMES units. The multiple tabu search algorithm was applied to simultaneously tune PID gains, membership functions and control rules of FL-PID controller to minimise frequency deviations of the system against load disturbances. Introducing LQR-Fuzzy technique with dynamic demand response control loop to LFC model was proposed in [Devi et al. \(2016\)](#). This paper presents an idea of introducing a DR control loop in the traditional LFC model (called LFC-DR) using intelligent controller for a power system. Researchers ([Mahto and Mukherjee, 2017](#)) have proposed a novel scaling factor based FL controller for frequency control of an isolated hybrid power system. It was revealed that the proposed controller was very much robust in nature and takes care of non-linearity very well while QOHS algorithm was adopted. The authors ([Obaid et al., 2016](#)) have proposed a fuzzy hierarchical approach-based optimal frequency control in the Great Britain power system. Structures of fuzzy controller offered high stability and robustness in the simulation results.

A novel hybrid DEPS optimised fuzzy PI/PID controller for LFC of multi-area interconnected power systems was proposed in [Sahu et al. \(2014\)](#). Robustness analysis was performed by varying the system parameters and operating load conditions from their nominal values. Intelligent droop control and power management of active generator for ancillary services under grid instability using FL technology was proposed in [Krim et al. \(2018\)](#). FL supervisor was developed to manage the power flows between the storage devices by choosing the optimal operating mode. Simulation based neuro-fuzzy hybrid intelligent PI control approach in four areas LFC of interconnected power system was proposed in [Prakash and Sinha \(2014\)](#). The advantage of this controller was that it can handle the non-linearities, and at the same time it was faster than other existing controllers. The authors ([Talaq and Al-Basri, 1999](#)) have proposed an adaptive fuzzy gain scheduling for LFC. The proposed model was extremely well suited to the task of smoothly interpolating linear gains across the input space when a very non-linear system moves around in its operating space.

3.2. LFC based particle swarm optimisation algorithm

PSO algorithm is one of the best algorithm in the artificial intelligence class. Multi-stage fuzzy LFC using PSO was proposed in [Shayeghi et al. \(2008\)](#). For achieving the desired level of robust performance, exact tuning of membership functions was very important. Intelligent frequency control in an AC microgrid on-line PSO-based tuning approach was presented in [Bevrani et al. \(2012\)](#). The performance of the proposed model was compared with the pure fuzzy PI and the Ziegler–Nichols PI control design methods. A novel hybrid PSO–PS optimised fuzzy PI controller for AGC in multi area interconnected power systems have proposed in [Sahu et al. \(2015c\)](#). Additionally, the proposed approach was further extended to multi-source multi area hydro thermal power system with/without HVDC link. Using a PSO and fuzzy rules the authors ([Dhillon et al., 2015](#)) presented a multi-area LFC. Heuristic procedures involving Particle Swarm Intelligence and Fuzzy based inferences have been employed to effectively obtain the optimised gains of PID controller. Any change in the load demand causes generator's shaft speed lower than the pre-set value and the system frequency deviates from the standard value results

in malfunctioning of frequency relays. The authors ([Barisall and Mishra, 2018](#)) have proposed an improved PSO based AGC of multi-source nonlinear power systems interconnected by AC/DC links. It is found that significant improvement in the system dynamic performance is achieved by considering parallel AC/DC lines in comparison to only AC tie lines between control areas.

3.3. LFC based genetic algorithm

Research on LFC based on GA can be found in the available literature. The authors ([Panda and Yegireddy, 2013](#)) have proposed an AGC of multi-area power system using multi-objective non-dominated sorting genetic algorithm-II. The proposed approach was first applied to a linear two-area power system model and then extended to a non-linear system model by considering the effect of governor dead band non-linearity. A modified GA based load frequency controller for interconnected power systems was proposed in [Ramesh and Krishnan \(2009\)](#). Floating point representation has been used, since it was more consistent, more precise and leads to faster convergence. Researchers ([Rerkpreedapong et al., 2003](#)) have proposed two robust decentralised control design methodologies for LFC. The first one is based on control design using linear matrix inequalities technique in order to obtain robustness against uncertainties. The second controller had a simpler structure, which was more appealing from an implementation point of view. Design of load frequency controllers using GA for two area interconnected hydropower system was proposed in [Aditiya and Das \(2003\)](#). As far as the authors can discover, no work has been done for the optimisation of the gain settings of different types of controllers using the GA for LFC of an interconnected hydropower system.

Authors ([Chang et al., 1998](#)) have proposed a LFC using GA based fuzzy gain scheduling of PI controllers. The control methodology adopts a formulation for the area control error which always guarantees zero steady-state values for both the time error and inadvertent energy. Multiobjective design of LFC using GAs was proposed in [Daneshfar and Bevrani \(2012\)](#). This gives rise to complex structure of such controllers and reduces their applicability conventional LFC systems that use classical or trial-and-error approaches to tune the PI controller parameters are more difficult and time consuming to design. LFC using GA based fuzzy gain scheduling of PI controllers was proposed in [Chang et al. \(1998\)](#). The methodology used a formulation for the ACE which always guarantees zero steady state. A new load frequency variable structure controller using GAs was introduced in [Al-Hamouz and Al-Duwaish \(2000\)](#). Selection of the variable structure controller (VSC) feedback gains by GAs was presented contrary to the trial and error selection of the variable structure feedback gains reported in the literature. The authors ([Ghoshal, 2004](#)) have proposed an application of GA/GA-SA based fuzzy AGC of a multi-area thermal generating system. Optimal integral gains and PID gains were computed by GA. Short term load frequency using fuzzy a neural network was proposed. A FNN initially creates a rule base from existing historical load data was proposed in [Bakirtizis et al. \(1995\)](#). The parameters of the rule base were then tuned through a training process, so that the output of the FNN adequately matches the available historical load data.

3.4. LFC other models based on artificial intelligence algorithm

This section gives the controllers models based on algorithm using artificial intelligence strategies. The research in [Sharma et al. \(2016\)](#) presents the design of optimal AGC regulators using an output feedback control strategy for a multi-area interconnected power system. [Barisall \(2015\)](#) has proposed a comparative performance analysis of TLBO for automatic LFC of multi-source

power systems. It was found that the dynamic performance of the proposed controller was better than that of recently published DE optimised controller and optimal output feedback controller and also the proposed system was more robust and stable to wide changes in system loading, parameters, size and locations of step load perturbation and different cost functions. Cui et al. (2017) have proposed an observer based robust integral sliding mode LFC for wind power systems. The proposed model not only guarantees the asymptotical stability of overall power systems but also capable of improving the system robustness. Numerical examples were provided to demonstrate the effectiveness of the proposed model. The researchers in Sondhi and Hote (2016) have proposed a fractional order PID controller to solve the LFC problem. Robust H_∞ for LFC solution was presented in Son et al. (2016). Qian et al. have presented a LFC by neural-network-based integral sliding mode for nonlinear power systems with wind turbine (Qian et al., 2016). By this scheme, not only are the update formulas obtained, but also the control system possesses the asymptotic stability. The simulation results by an interconnected power system illustrate the feasibility and validity of the presented method.

Emotional learning-based intelligent controller was used to solve LFC problem in Farhangi et al. (2012). The controller includes a neuro-fuzzy system with power error and its derivative was used as inputs. A fuzzy critic evaluates the present situation, and provides the emotional signal or stress. The controller modified its characteristics so that its critic stress was reduced. An improving sliding mode design for LFC of power system integrated an adaptive learning strategy was proposed in Mu et al. (2017). The adaptive dynamic programming strategy is used to provide the supplementary control signal, which is beneficial to the frequency regulation by adapting to the real-time disturbances and uncertainties. An H_∞ tracking performance criterion was introduced to minimise the approximation errors and the external disturbance effects. Considering a realistic power system with multi-source power generation based LFC was proposed in Parmar et al. (2012). Usually only a reduced number of state variables or linear combinations thereof, are available. To resolve this difficulty, optimal output feedback controller which uses only the output state variables was proposed. LFC of power system under deregulated environment using optimal firefly algorithm was proposed in Sekhar et al. (2016). To investigate the effectiveness of the proposed approach, time domain simulations are carried out considering different contracted scenarios and the comparative results are presented. Majumder et al. have proposed a LFC for rural DG was proposed in Majumder et al. (2010). The performances of these two proposed controllers were compared with that of a controller, which includes an expensive high bandwidth communication system through time-domain simulation of a test system. The magnitude of errors in power sharing between these three droop control schemes are evaluated and tabulated.

The research proposed in Khederzadeh et al. (2016) proposed a LFC improvement of two adjacent microgrids in autonomous mode using back to back voltage-sourced converters. By application of the proposed algorithm, two microgrids could play the role of an auxiliary supply-demand for each other without the necessity of implementing a communication link between the two microgrids. Cooperative control of power system load and frequency by using differential games was proposed in Chen et al. (2015). With two areas and three areas LFC models, a non-cooperative equilibrium solution, and two cooperative equilibrium solutions with different time consistency properties were derived. Management and control for smart microgrid based on hybrid control theory was proposed in Dou et al. (2011). On the basis of the proposed model, a two-level hierarchical hybrid control was proposed based on the hybrid system control theory

in terms of interactive adjustment between the continuous controller at the lower level and discrete management at the upper level. A sampled data automatic LFC of a single area power system with multi-source power generation was proposed in Ramakrishna and Bhatti (2007). The authors investigated the effect of sampling period of the controller signal on the performance of the continuous system. H-infinity LFC of interconnected power systems with communication delays was proposed in Dey et al. (2012). The model has considered the LFC design incorporating the effect of using open communication network. Further results on delays-dependent stability of multi-area LFC was proposed in Zhang et al. (2013). Based on Lyapunov theory and the linear matrix inequality technique, a new stability criterion was proposed to improve calculation accuracy and reduce the computation time. Fig. 4 shows new configuration of the power system.

Hasan et al. (2016) have proposed an ABT based LFC of interconnected power system. A commercial case study was carried out to demonstrate effectiveness of the proposed model. LFC of interconnected power system via multi-agent system method was proposed in yang et al. (2017). In the control frame, the upper-level agent, in a centralised way, coordinates the lower-level LFC agents to deal with the conflict between narrowing the ACE and stabilising the power system frequency. Abdelaziz and Ali (2016) have proposed a load frequency controller design via artificial Cuckoo search algorithm. Simulation results were presented to prove the improvement achieved using Cuckoo algorithm. Load frequency controller design via BAT algorithm for nonlinear interconnected power system was proposed in Elazim and Ali (2016). Evaluation of results shows that the proposed model achieved good robust performance for wide range of system parameters and load changes. LFC of interconnected power system with governor backlash nonlinearities was presented in Tsay (2011). The authors (Kennedy et al., 1988) have proposed a variable, non-linear tie-line frequency bias for interconnected systems control. Variable, non-linear tie-line frequency bias is a better simulation of electric system frequency response than fixed straight line bias because it recognises the variable nature of a system's reaction to frequency changes. Discrete mode AGC of a two areas reheat thermal system with new area control error was proposed in Kothari et al. (1989). The research dealt with discrete mode AGC of an interconnected reheat thermal system considering a new area control error based on tie-line power deviation, frequency deviation, time error and inadvertent interchange.

A variable structure load frequency controller for multi-area power systems was proposed in Al-Hamouz and Magid (1993). Two designs were presented: the optimal variable structure load frequency controller (OVSLFC) and the pole placement variable structure load frequency controller (PPVSLFC). LFC of interconnected power systems via minimum variance regulator was proposed in Aly et al. (1984). It was shown that the detuned minimum variance regulator with extended least-squares estimation techniques gives better results than the other regulator. LFC of interconnected power system with governor backlash nonlinearities was presented in Tsay (2011). The considered system is a nonlinear multivariable feedback control system. Researchers (Mohanty et al., 2014) have proposed a controller parameters tuning of differential evolution (DE) algorithm and its application to LFC of multi-source power system. The superiority of the proposed approach has been shown by comparing the results with recently published optimal output feedback controller for the same power systems. The authors (Khalghani et al., 2016) have proposed a self-tuning LFC strategy for microgrids: Human brain emotional learning. Simulation results have shown the effectiveness of the emotional controller. Researchers (Elgerd and Fosha, 1970) have proposed an optimum megawatt-frequency

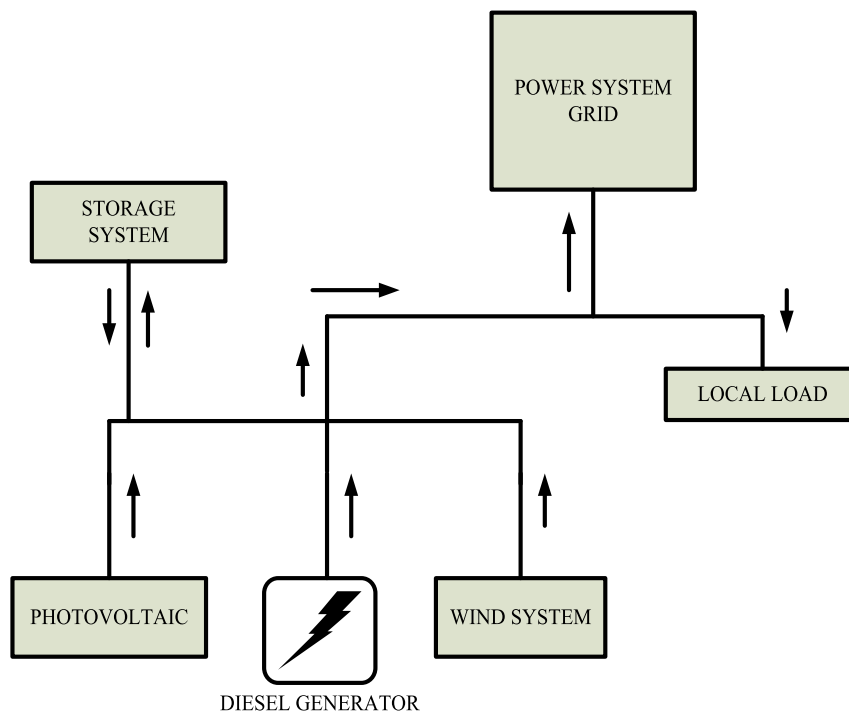

Fig. 4. New power system configuration.

control of multi-area electric energy systems. The P-f control problem has been selected for critical examination.

A new smart charging method for electric vehicles for frequency control of smart grid was introduced in [Falahati et al. \(2016\)](#). A smart charging method based on fuzzy controller was proposed, in which charging process was performed with respect to the frequency deviation of grid and state of charge (SOC) of EV battery. An improved control scheme based in droop characteristic for microgrid converters was introduced in [Arboleya et al. \(2010\)](#). The modifications added to the control were based on a feed forward current control that allows the converter to work in several modes. AGC of an interconnected hydrothermal system in continuous and discrete modes considering generation rate constraints (GRC) was introduced in [Nanda et al. \(1983\)](#). A comprehensive procedure for continuous and discrete-mode optimisation of integral controllers using an integral squared error criterion was suggested. Optimisation of LFC parameters for power systems with reheats steam turbines and governor dead band nonlinearity was proposed ([Tripathy et al., 1982a](#)). It was shown that the governor dead band (backlash) nonlinearity tends to produce a continuous oscillation in the area frequency and tie-line power transient response. Design and analysis of DE algorithm based AGC for interconnected power system was introduced in [Rout et al. \(2013\)](#). The design problem was formulated as an optimisation problem control and DE was employed to search for optimal controller parameters.

NERC's control performance standards based load frequency controller for a multi-area deregulated power system with ANFIS approach was introduced in [T and Fathima \(2018\)](#). The proposed controller was tested on the Indian regional grid system and its control performance standards were compared with the conventional PID controller and ANFIS controller. AGC of multi-area power systems with diverse energy sources using TLBO algorithm was proposed in [Sahu et al. \(2016a\)](#). The design problem was formulated as an optimisation problem and TLBO was employed to optimise the parameters of the PID controller. The authors ([Shiva and Mukherjee, 2016](#)) have proposed a novel

quasi-oppositional harmony search algorithm for AGC optimisation of three-area multi-unit power system after deregulation. The concerned objective was to intensify the deregulated AGC operation followed by load disturbances. Comparative performance evaluation of fractional order controllers in LFC of two areas diverse unit power system with considering GDB and GRC effects were proposed in [Morsali et al. \(2018\)](#). Tuneable parameters were adjusted via an improved PSO algorithm which was powered by chaotic parameter and crossover operator to find a globally optimal solution. Demand response for frequency control of multi-area power system was introduced in [Bao et al. \(2017\)](#). In order to quickly stabilise the frequency of different areas, the tie-line power was adopted as the additional input signal of demand response. AGC of a Multi-area Hydro-thermal System with BES and firefly optimised PID controller was introduced in [Dash et al. \(2014\)](#). A BES was incorporated in area 1 and the system dynamic responses were compared with that of without BES system.

Discrete variable structure controller for LFC of multi-area interconnected power systems was proposed in [Kumar et al. \(1987\)](#). A discrete version of a VSC for LFC of a two-area thermal and multi-area interconnected power system was presented. The authors ([Tripathy et al., 1982b](#)) have proposed an optimisation of LFC parameters for power systems with reheats steam turbines and governor dead-band nonlinearity. When proportional feedback of area frequency error was used to stabilise the response it found that only overshoot was reduced, but settling time remains the same. TLBO algorithm based fuzzy-PID controller for AGC of multi-area power system was proposed in [Sahu et al. \(2015\)](#). For the first time teaching-learning based TLBO algorithm was applied in this area to obtain the parameters of the proposed fuzzy-PID controller. LFC management in island operation was introduced ([Maslo and Kolcun, 2014](#)). A number of possibilities for the cooperation of turbine control modes and supervisory control of frequency and active power were investigated and evaluated. The authors ([Vrdoljak et al., 2010](#)) have proposed a sliding mode based LFC in power systems. A new discrete time sliding mode controller for LFC in control areas of a power system was presented. Intelligent controllers for LFC of two area power

system were introduced in [Azeer et al. \(2017\)](#). The objective was to eliminate errors due to the disturbances in both frequency and tie-line power so as to ensure an economic power generation.

Coordinated control of distributed energy resources (DERs) to support LFC was proposed in [Pandi et al. \(2015\)](#). The error in feeder power flow with respect to scheduled value was utilised by the PI controller to estimate the change in power reference of all DER units. A new intelligent online fuzzy tuning approach for multi-area LFC self-adaptive modified Bat algorithm was introduced in [Khooban and Niknam \(2015\)](#). The proposed controller guarantees stability and robustness against uncertainties caused by external disturbances and impermanent dynamics that power systems face. A hybrid firefly algorithm and pattern search technique for AGC of multi-area power systems was introduced in [Sahu et al. \(2015b\)](#). The proposed approach was extended to multi-area multi-source hydro thermal power system with or without considering the effect of physical constraints. The authors ([Gozde et al., 2012](#)) have proposed a comparative performance analysis of Artificial Bee Colony (ABC) algorithm in AGC for interconnected reheat thermal power system. The robustness analysis was applied to the power system which was optimised by ABC algorithm. Analysis of frequency sensitive wind plant penetration effect on LFC of hybrid power system was proposed in [Aziz et al. \(2018\)](#). Simulation results presented here provides some guidance on the design parameters of frequency regulation scheme in the presence of frequency sensitive wind plant. The authors in [Yang et al. \(2002\)](#) have proposed a decentralised power system LFC beyond the limit of diagonal dominance. The robust stability condition for the overall system can be easily stated as to achieve a sufficient interaction margin, and a sufficient gain and phase margin during each independent design. Load frequency control of interconnected power system using grey wolf optimisation (GWO) was proposed in [Guha et al. \(2016\)](#). The controller gains were optimised by using GWO algorithm employing integral time multiplied absolute error based fitness function.

3.5. LFC based on decentralised techniques

Some authors have proposed the solution of the LFC problem using the decentralised control models. [Yang et al. \(2002\)](#) have proposed a decentralised power system LFC beyond the limit of diagonal dominance. Based on the presented model each local controller can be design independently. Decentralised adaptive LFC in a multi-area power system was proposed in [Minh et al. \(2018\)](#). The particularity of that research was the aggregation stage was performed by the use of an adaptive optimal decentralised control law. The proposed controller was found to be simple in structure and easy for implementation. [Tan et al. \(2012\)](#) have proposed a decentralised LFC in deregulated environments. A method to analyse the stability of the decentralised LFC for normal environments was also extended to the deregulated case. Using a coefficient diagram method the authors in [Bernard et al. \(2014\)](#) have presented a new decentralised model for LFC in an interconnected power system. The designed method reduced the effects of uncertainties owing to variations in the parameters of governors and turbines as well as load disturbances.

Decentralised LFC controller for a multi-area interconnected was proposed in [Alrifai et al. \(2011\)](#). The simulation results indicate that the proposed control scheme works well. In addition, they show that the controlled system is robust to changes in the parameters of the power system and to bounded input disturbances acting on the system. The authors in [Ray et al. \(2005\)](#) have presented a multi-area LFC of power systems, a decentralised variable structure approach. The proposed decentralised control was more practical than the centralised control scheme for this

problem and ensures to attenuate the frequency and tie-line power deviations to zero due to different operating conditions and load changes. Decentralised sliding mode LFC for multi-area power systems was presented in [Mi et al. \(2013\)](#). The PI switching surface was constructed for each area to improve system dynamic performance in reaching intervals. Distributed LFC in an interconnected power system using ecological technique diagram method was proposed in [Mohamed et al. \(2016\)](#). The control structure was built on the frequency response model of multi-area power system, and physical constraints of the governors and turbines.

3.6. LFC based on dual mode approach

Some dual models based control of frequency are proposed in this section. The design of biogeography optimisation based dual mode gain scheduling fractional order PI load frequency controllers for multi-source interconnected power systems was presented in [Sathya and Ansira \(2016\)](#). The model was based on dual mode gain scheduling of fractional order PI controller and provided one more degree of freedom in comparison with the conventional PI controller. The dual mode concept was also incorporated and the system performance was improved. The authors ([Kumar and Ansari, 2016](#)) have proposed a new design of dual mode Type-II fuzzy logic load frequency controller for interconnected power systems with parallel AC–DC tie-lines and capacitor energy storage unit. The dual-mode concept is incorporated in the proposed controller to improve the system performance. A DC link was connected in parallel with AC tie-line to stabilise the frequency of oscillations. Researchers ([Velusami and Chidambaram, 2006](#)) have proposed a design of decentralised biased dual mode controllers for LFC of interconnected power systems. The proposed controller was simple in structure and easy for implementation. Dual mode control applied for power generation control was proposed in [Kumar et al. \(1984\)](#). The proposed controller was simple in structure and easily implementable. Decentralised biased dual mode controllers for LFC of interconnected power systems considering GDB and GRC nonlinearities was proposed in [Velusami and Chidambaram \(2007\)](#). The closed loop system was simulated, and the frequency and tie line power deviations resulting from a step load disturbance were presented. The proposed model considered effects of nonlinearities in the design phase. [Sathya and Ansari \(2015\)](#) have presented a LFC using BAT inspired algorithm based dual mode gain scheduling of PI controllers for interconnected power system. The model provided a better transient as well as steady state of response.

3.7. LFC based FACTS and storage system

The contribution or importance of the battery in the new power system is no longer demonstrated. Most of the renewable energy sources are weather dependent and not available at any time and the battery can be used to supply the load on time of unavailability of these sources. [Chandrakala et al. \(2014\)](#) have presented a LFC of multi-source multi-area hydro thermal system using flexible alternating current transmission system (FACTS) devices. An impact of energy storage system on LFC for diverse sources of interconnected power system in deregulated power environment was presented in [Shankar et al. \(2016b\)](#). The proposed control mechanism has been analysed in a deregulated power environment with the help of different simulation case studies to find out improved dynamic performance over integral control strategies. LFC of an interconnected reheat thermal system using type-2 fuzzy system including SMES units was proposed in [000]. The performance of the Type-2 (T2) fuzzy controller is compared with optimal PID (Khamsum's optimal

PID) controller and Fuzzy PI Controller (Type-1 Fuzzy) controller in the presence of GRC, BD and SMES. LFC in deregulated power system integrated with super SMES-Thyristors controlled phase shifters combination using adaptive neuro fuzzy system controller was proposed (Pappachen and Fathima, 2016). The dynamics of the proposed model was analysed with unilateral, bilateral and contract violation cases for a small load perturbation. The authors (Nandi et al., 2017a) have proposed a frequency stabilisation of multi-area multi-source interconnected power system using TCSC and SMES mechanism. The step load perturbation (SLP) and random SLP are used for the dynamic performance analysis. Adaptive AGC with SMES in power systems was presented (Tripathy et al., 1992). A comprehensive comparative performance evaluation of control schemes using adaptive and non-adaptive controllers in the main AGC and in the SMAES control loops was presented.

Effect of battery energy storage system (BESS) on LFC considering governor dead-band and GRC was presented (Lu et al., 1995). Computer simulations shown that the BES was very effective in damping the oscillations caused by load disturbances. Control of a SMES for mitigating sub-synchronous oscillations in power systems: a PBC-PI approach was presented in Gonzalez et al. (2018). The proposed methodology was assessed with a classical PI controller, feedback linearisation controller and a passivity-based PI control (PI-PBC). The authors (Luo et al., 2014) have presented an optimal sizing and control strategy of isolated grid with wind power and ESS. The optimal size of the ESS was determined by genetic algorithm and sequential simulation. The annualised cost considering the compensation cost of curtailed wind power and load is minimised when the reliability requirement can be satisfied. A comprehensive study of battery-supercapacitor hybrid ESS for standalone PV power system in rural electrification was proposed (Jing et al., 2018). The existing hybrid ESSs and their corresponding energy management strategies vary in terms of topology, complexity and control algorithm which are often application oriented. Researchers (Dhundhara and Verma, 2018) have proposed capacitive energy storage with optimised controller for frequency regulation in realistic multi-source deregulated power system. In addition, the effectiveness of the sine-cosine algorithm tuned PI controller was also compared with the popular PSO algorithm. A self-interested distributed economic MPC approach to BES networks was proposed in Wang et al. (2019). To solve this problem, dissipativity theory with dynamic supply rates was adopted in that paper to deal with the interactions between individual users and the MPM.

The authors (Fujimoto et al., 2009) have proposed a LFC using storage system for a microgrid. A power storage system was used with photovoltaic generation and wind power generation. Storage as a flexibility option in power systems with high shares of variable renewable energy sources: a POLES-based analysis was presented in Després et al. (2017). The innovative aspect of their work was the direct coupling between POLES and EUCAD, thus combining a long-term simulation horizon and a short-term approach for the power system operation. AGC with fuzzy logic controllers in the power system including SMES units was proposed in Demiroren and Yesil (2004). The zero steady-state error was obtained after sufficient delay time. The authors (Shankar et al., 2016a) have proposed a small-signal stability analysis for two area interconnected power system with load frequency controller in coordination with FACTS and energy storage device. The proposed control scheme consists of an integral controller in coordination with the redox flow energy storage system (RFESS) and the static synchronous series compensator (SSSC). Smart energy management algorithm for load smoothing and peak shaving based on load forecasting of an island's power system was proposed in Chapaloglou et al. (2019). The prediction module was

based on a feedforward artificial neural network, capable of short term day ahead load forecasting. Impact of energy storage units on LFC of deregulated power systems was presented in Selvaraju and Somaskandan (2016). The research proposed a new design of intelligent controller for LFC of interconnected deregulated power systems with ESS using artificial cooperative search algorithm. Control performance standards based load frequency controller considering redox flow batteries coordinate with interline power flow controller was proposed in Chidambaram and Paramasivm (2012). The redox flow batteries, which were not aged to the frequent charging and discharging, have a quick response and outstanding function during overload conditions.

Comparative performance evaluation of SMES–SMES, TCPS–SMES and SSSC–SMES controllers in AGC for a two-area hydro–hydro system was presented in Bhatt et al. (2011). To compensate for such load disturbances and stabilise the area frequency oscillations, the dynamic power flow control of SSSC or thyristors controlled phase shifters (TCPS) in coordination with SMES were proposed. The authors (Muzhikyan et al., 2016) have proposed relative merits of load following reserves and ESS market integration towards power system imbalances. The results show that load following reserves and ESS mitigate imbalances in fundamentally different ways. Optimisation and energy management of a standalone hybrid microgrid in the presence of BSS was proposed in Moradi et al. (2018). In order to achieve optimal utilisation of renewable resources in a microgrid environment and system cost-effective operations, the effectiveness of a BSS unit was examined. The authors (Colbertaldo et al., 2019) have proposed the impact of hydrogen energy storage on California electric power system: Towards 100% renewable electricity. Novelty of the study was the assessment of hydrogen as the primary storage means for balancing energy supply and demand on a large scale. BES for LFC of an interconnected power system was proposed in Aditya and Das (2001). Time domain simulations were used to study the performance of the power system and BES system. Frequency stabilisation of multi-area multi-source interconnected power system using TCSC and SMES mechanism was presented in Nandi et al. (2017b). The SLP and random SLP were used for the dynamic performance analysis.

Researchers (Muyeen et al., 2014) have proposed the transient stability enhancement of wind farms connected to a multi-machine power system by using an adaptive ANN-controlled SMES. The control strategy of SMES depends mainly on a sinusoidal pulse width modulation (PWM) VSC and an adaptive ANN controlled DC–DC converter using insulated gate bipolar transistors (IGBTs). Frequency response services designed for energy storage was proposed in Kerdphol et al. (2016). Novel statistical techniques have been devised to quantify the design and operational requirements of ESS providing frequency regulation services. Optimum BESS using PSO considering dynamic demand response for microgrids was presented in Greenwood et al. (2017). The optimum size of BESS was evaluated by PSO incorporating DR based on frequency control of the microgrid. The authors (Arya, 2019) have proposed an AGC of PV-thermal and hydro-thermal power systems using CES and a new multi-stage FPIDF – (1 + PI) controller. Motivated by the fact that fuzzy control techniques display superior performance under volatile operating conditions in contrast to conventional control strategies. Optimisation under uncertainty of a biomass-integrated renewable energy microgrid with energy storage was presented in Zheng et al. (2018). As an illustrative example, a case study was examined for a conceptual utility grid-connected microgrid application in Davis, California. BESSs as a way to integrate renewable energy in small isolated power systems were proposed in Branco et al. (2018). The BESS was inserted in to the Unit Commitment and Economic Dispatch platform and regarded as another dispatchable generator. Supercapacitor based energy storage system for improved LFC was

proposed in [Mufti et al. \(2009\)](#). The fuzzy controller for SCB was designed in such a way that the effects of load disturbances were rejected on a continuous basis.

Small-signal stability analysis for two-area interconnected power system with load frequency controller in coordination with FACTS and energy storage device was presented in [Shankar et al. \(2016a\)](#). The proposed control scheme consists of an integral controller in coordination with the RFESS and the SSSC. Placement and sizing of BES for primary frequency control in an isolated section of the Mexican power system was proposed in [Ramirez et al. \(2018\)](#). BESS location and size were determined according to the most severe contingency for generation outage and different penetration levels of converter based renewable generation in the test system. A hybrid DE-PS algorithm for LFC under deregulated power system with UPFC and RFB was proposed in [Sahu et al. \(2015a\)](#). The superiority of proposed hybrid differential evolution and Pattern search optimised MID controller over GA and DE techniques was demonstrate. A SOC oriented charging scheme was developed to control the BES to smooth the PV output. Researchers ([Cardoso et al., 2018](#)) have proposed a battery ageing in multi-energy microgrid design using mixed integer linear programming. The battery ageing model and its integration into a larger microgrid sizing formulation were described. The authors ([Hu et al., 2018](#)) have proposed a MPC strategy of PV-Battery microgrid under variable power generations and load conditions. In this paper, a microgrid with solar photovoltaic (PV) and BES was studied. The authors ([Khezri et al., 2019](#)) have proposed an intelligent coordinator design for GCSC and AGC in a two-area hybrid power system. With constant gains that are generally designed for fixed operating conditions, the outlined approach demonstrates robust performance. AGC with thyristors controlled series compensator including SMES units was proposed in [Padhan et al. \(2014\)](#). After that performance of thyristors controlled series compensator (TCSC) has been investigated.

AGC of a multi-area power system under deregulated environment using redox flow batteries and interline power flow controller was proposed in [Gorripotu et al. \(2015\)](#). Additionally, to get an accurate insight of the AGC problem, important physical constraints were considered and the controller parameters have been retuned. PI^2 controller based coordinated control with redox flow battery and unified power flow controller (UPFC) for improved restoration indices in a deregulated power system was proposed in [Thirunavukarasu and Chidambaram \(2016\)](#). The evaluation of power system restoration indices based on the AGC assessment of interconnected power system in a deregulated environment was presented. Optimal design of MPC with SMES for LFC of nonlinear hydrothermal power system using bat inspired algorithm was introduced in [Elsisi et al. \(2017\)](#). The model was applied to simultaneously tune the parameters of MPC controller and SMES to minimise deviations of frequency and tie-line power flow of the interconnected. The authors in [Pradhan et al. \(2016\)](#) have proposed the firefly algorithm optimised fuzzy PID controller for AGC of multi-area multi-source power systems with UPFC and SMES. The superiority of the proposed firefly algorithm optimised fuzzy PID controller has been demonstrated by comparing the results with some recently published approaches. Application of UPFC in interconnected power systems: modelling, interface, control strategy, and case study was introduced in [Huang et al. \(2000\)](#). The supplementary control of UPFC was added for damping power oscillation.

LFC in deregulated power system integrated with SMES-TCPS combination using ANFIS controller was proposed in [Pappachen and Fathima \(2016\)](#). The implementation of SMES-TCPS combination arrests the initial fall in frequency as well as the tie line power deviations after a sudden load disturbance.

3.8. LFC based on robust model

Some robust controllers are presented in the literature. [Toulabi et al. \(2014\)](#) have presented a robust decentralised PI and design of power system LFC using the Kharitonov's theorem in a multi-area. This theorem was used to determine the robustness margin. A robust method of tuning the feedback gains of a variable structure LFC controller using GA optimisation was presented in [Huddar and Kulkarni \(2008\)](#). The authors have compared the system performance against step load variations with the conventional trial and error method. [Khodabakhshian and Edrisi \(2008\)](#) have proposed a new robust PID load frequency controller. The proposed controller was straightforward and effective. A robust adaptive LFC for microgrids was presented in [Khooban et al. \(2016b\)](#). The simulations results prove the successfulness and effectiveness of the proposed method. [Zhu et al. \(2017\)](#) have proposed a robust LFC with dynamic demand response for deregulated power systems considering communication delays. A robust PID-LFC controller was designed through the H_∞ performance analysis and the PSO searching algorithm. Robust stability of networked LFC systems with time-varying delays was proposed in [Krishnan et al. \(2017\)](#). Using Lyapunov-Krasovskii functional approach, a less conservative stability criterion was presented to ascertain delay-dependent stability of such LFC systems. [Tan and Xu \(2009\)](#) have proposed a robust analysis and design of load frequency controller for power systems. The proposed method took into account the un-modelled dynamics of power systems.

The research presented in [Tan and Zhou \(2012\)](#) has proposed a robust analysis of decentralised LFC for multi-area power systems. A detailed structured singular value method was proposed for local-area robustness analysis and an eigenvalue method was derived for the tie-line robustness analysis. The authors in [Sudha and Santhi \(2011a\)](#) have proposed a robust decentralised LFC of interconnected power system with generation rate constraint using type-2 fuzzy approach. The performance of fuzzy type-2 was compared with the conventional controller and type-1 fuzzy controller with regard to generation rate constraint. Robust H_∞ LFC in hybrid DG system was presented in [Singh et al. \(2013\)](#). The PSO based loop shaping of H_∞ controller was used and compared with those obtained with GA to minimise the frequency deviation. Robust decentralised LFC using an iterative linear matrix inequalities algorithm was presented in [Bevrani et al. \(2004\)](#). The model was formulated as an H_∞ -control problem and is solved using an iterative linear matrix inequalities algorithm to design of robust PI controllers in the multi-area power systems. A robust PID controller based on imperialist competitive algorithm for LFC of power systems was introduced in [Shabani et al. \(2013\)](#). A new PID controller for resistant differential control against load disturbance is introduced that can be used for LFC application. The authors ([Sudha et al., 2016](#)) have proposed a fuzzy C-Means clustering for robust decentralised LFC of interconnected power system with GRC. The simple and efficient clustering algorithms permit the classification of the data in distinct groups using distance and/or similarity functions.

[Sun et al. \(2016\)](#) have proposed a robust H_∞ LFC of delayed multi-area power system with stochastic disturbances. Based on Lyapunov stability theory, several less conservative stability conditions was developed in the form of linear matrix inequalities to ensure the frequency stability of multi-area power system. A FL approach based robust LFC for uncertain nonlinear power systems was introduced in [Lee et al. \(2006\)](#). Sufficient conditions for the robust asymptotic convergence of the frequency deviation are then provided in terms of linear matrix inequalities. [Ahmadi and Aldeen \(2017\)](#) have introduced a robust overlapping load frequency output feedback control of multi-area interconnected

power systems. The overlapping LFC design was based on the expansion–contraction principles. The research in [Nandar \(2016\)](#) introduced a robust PI control of smart controllable load for frequency stabilisation of microgrid power system. To guarantee the robustness of the proposed PI controller, an inverse additive perturbation was formulated as an optimisation problem. The research in [Liao and Xu \(2017\)](#) proposed a robust LFC scheme for power systems based on second order sliding mode and extended disturbance observer. The merits of the scheme include faster response speed, stronger robustness against disturbances arising from power system parameter errors and unmodelled dynamics. The authors in [Yazdizadeh et al. \(2012\)](#) have proposed a decentralised model based on a new robust optimal multiple input and single output PID controller. The proposed model supports a trade-off between acceptable and desired performance and robustness at the same time.

[Chidambaram and Velusami \(2005\)](#) have proposed a design of decentralised biased controllers for LFC of interconnected power systems. According to the proposed method the biased controllers were less sensitive to the changes in system parameters. The research in [Fathima and Khan \(2008\)](#) has proposed a design of a new market structure and robust controller for the frequency regulation service in the deregulated power system. The dynamic performance of the charged-bilateral structure is analysed through a simulation of a step load disturbances to examine its regulation capabilities for normal operating load contract violation issues. [Patra et al. \(2007\)](#) have proposed a design of robust load frequency controller H_∞ loop shaping approach. The real μ -analysis was adopted to ensure the robust stability of system.

The design of a fractional order PID controller using gases Brownian motion optimisation algorithm for LFC with governor saturation consideration was proposed in [Zamani et al. \(2016a\)](#). Based in time domain, the performance and robustness of the model was verified.

The research in [Khodabakhshian et al. \(2012\)](#) proposed a design of a robust LFC using sequential quadratic programming technique. The robustness of the proposed controller was compared with that of a conventional PI controller. A FL based fine-tuning approach for robust LFC in a multi-area power system was presented in [Khezri et al. \(2016\)](#). The model performance was compared with two extra robust methods. A fuzzy sliding model LFC of multi-area interconnected power systems was proposed in [Xiangping et al. \(2001\)](#). Simulation results show that the presented algorithm was simple, effective and ensure that the overall system is asymptotically stable. LFC problem in interconnected power systems using robust fractional PI ^{λ} D controller was proposed in [Delassi et al. \(2018\)](#). The controller parameters were tuned through new evolutionary algorithm known as differential evolution. Another robust controller design of SSSC for stabilisation of frequency oscillations in interconnected power systems was presented in [Ngamroo and Kongprawechnon \(2003\)](#). To implement this concept, the robust design method of the lead/lag controller equipped with the SSSC was proposed. LMI based robust LFC for time delayed power system via delay margin estimation was presented in [Xiong et al. \(2018\)](#). The robust controller gains are ultimately obtained with the estimated delay margin and a binary search technique which aims to find the minimum value of RPI. Research ([Bevrani and Hiyama, 2007](#)) proposed a robust load frequency regulation real time laboratory experiment. In the proposed methodology, the LFC problem was reduced to a static output feedback control synthesis for a multiple delays power system, and then the control parameters are easily carried out using robust H_∞ control technique. Decentralised robust adaptive output feedback controller for power system LFC was presented in [Kazemi et al. \(2002\)](#). An adaptive observer was designed to estimate the state variables and system

parameters using local data. LFC based on differential evolution optimised parallel 2-DOF PID controller was presented in [Sahu et al. \(2013\)](#). It was observed that the proposed controllers are quite robust for a wide range of the system parameters and operating load conditions from their nominal values. A model based on adaptive optimal gain scheduling for the LFC problem was presented in [Abdennour \(2002\)](#). The obtained gains were used to train the adaptive network-based fuzzy inference system. Another adaptive decentralised LFC of multi-area power systems was proposed in [Zribi et al. \(2005\)](#). The control scheme guarantees that the fluctuations of the LFC converge to a range, which can be made very small. A robust adaptive load frequency control for microgrids was proposed in [Khooban et al. \(2016a\)](#). A new combination of the General Type II Fuzzy Logic Sets and the modified harmony search algorithm technique is applied for adaptive tuning of PI controller. Robust decentralised LFC of interconnected power system with GRC using Type-2 fuzzy approach was presented in [Sudha and Santhi \(2011b\)](#). The performance of the Type-2 (T2) controller was compared with conventional controller and Type-1 (T1) fuzzy controller with regard to GRC.

4. Model predictive control strategy

The algorithm named Model Predictive Control (MPC) belongs to a category of artificial intelligence algorithms that computes in a sequential manner using adjustments of manipulated variables to optimise and predict the future behaviour of the system, shows in [Fig. 5](#). MPC is considered as one of the advanced control techniques in the control area ([Wang, 2009](#); [Elsisi et al., 2016](#); [Zheng et al., 2017](#)). Its theoretical development over years can be seen by the amount of research available in the literature. With regards to the solution of LFC problem in power networks, some research can be found in the literature.

4.1. Predictive control strategies

Considering the imbalance uncertainty in the power system a predictive load frequency control model was presented in [Elsisi et al. \(2016\)](#). The presented model was based on the simplified system model that was updated using the Kalman algorithm for estimation of state and parameter considering the tie-line flow limit. The second model incorporating tie-line power flow limit, the capacity of generation units, and their change rate was proposed in [Ersdal et al. \(2016b\)](#). According to this research, considering certain problems of LFC, the MPC is a more realistic solution to the issues that power systems are dealing with nowadays. A model predictive LFC was presented in [Ersdal et al. \(2016a\)](#). The proposed simplified MPC model took into account the existing network configuration and the power flow limitation in the tie-lines. [Kassem \(2010\)](#) has proposed a model predictive controller based on a neural network of a two microgrids LFC for improving the power grid dynamic performance. The effectiveness of the presented approach was demonstrated over an LFC using a FL controller. [Table 1](#) summarises some of the MPC models used to solve LFC problem in power system. [Khalid and Savkin \(2012\)](#) have proposed LFC based MPC for an optimal control of wind BESS. A model based on the prediction of frequency using Grey theory was also designed to optimise the performance of the basic predictive controller. An economic aspect included in MPC to solve the LFC in one control area that was presented in [Sokoler et al. \(2015\)](#). The authors have proposed an operation cost reduction approach considering an order of magnitude similar to those based on the difference ratio of two set points MPC and PI controller. Active power control of two microgrids interconnected via two alternating current tie-lines was proposed ([Tungadio](#)

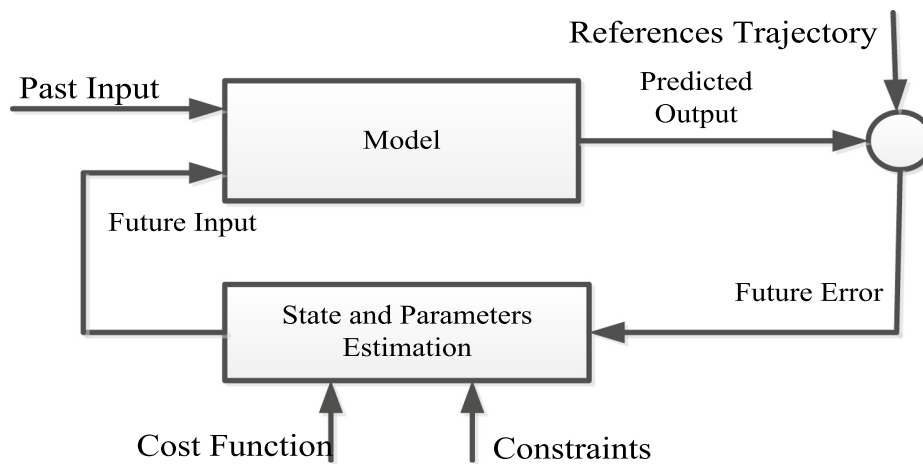

Fig. 5. Model predictive control strategy (Tungadio et al., 2018b).

et al., 2018b). Three different cases were introduced in the studied system to show the effectiveness of the model.

The authors in Morattab et al. (2011) have proposed a decentralised MPC for LFC in deregulated power systems under harsh conditions. To nullify the effects on frequency deviations, the MPC controller used feed-forward control strategy in each area. Power system MPC-LFC was presented in Zhao et al. (2016). The authors have modelled the limit of governor valve using the fuzzy logic method and the local model predictive controllers were included into a nonlinear control system strategy. A model predictive control strategy method was developed for a LEED silver community college building that contains an advanced common loop heat pump HVAC system. MPC is performed using persistence based climate (Hilliard et al., 2016). MPC based LFC design concerning wind turbines was introduced in Mohamed et al. (2012). The proposed model introduced the fast response of frequency of a connected area power system taking into account WT's generation. Zhang et al. (2015) have proposed an MPC for a reliable LFC with WT's. The algorithm used has reduced the impact of the randomness and intermittency of wind turbines effectively. Zheng et al. (2016) have presented a design of a multi-mode intelligent MPC control strategy for hydroelectric generating unit. The model was built on the basis of a tree seed algorithm and the stability guaranteed measures into rolling optimisation mechanism of nonlinear MPC to replace the existing complex numerical differential geometric solutions. A functional MPC approach for power system LFC considering GRC was proposed in Shiroei et al. (2013a). To alleviate computational effort and to reduce numerical problems, particularly in large prediction horizon, an exponentially weighted functional MPC was employed. A model predictive based LFC design concerning wind turbines was introduced in Mohamed et al. (2012). Each local area controller was designed independently such that stability of the overall closed loop system was guaranteed. Frequency stabilisation of renewable power systems based on MPC with application to the Egyptian grid was presented in Magdy et al. (2018). The proposed technique provided stabilisation of renewable power systems with inherent nonlinearities.

4.2. Distributed MPC

Distributed model predictive LFC it is one of the techniques used on control of the frequency control. The overall system can be decomposed into several subsystems and each has its own local area MPC controller. Liu et al. (2016a) have presented a distributed model predictive control for active load frequency

control with dynamic fuzzy valve position modelling for hydro-thermal power system. The limit position of the governor valve was modelled by fuzzy model and the local predictive controllers, simulations results were successful. Another distributed model for predictive LFC of multi-area power system after deregulation was proposed in Ma et al. (2017). The authors took into account the effect of bilateral contracts on the dynamics. The authors (Zhang et al., 2017) have presented a distributed MPC-LFC of multi-area power system with DFIGs. A performance comparison between the proposed controller with and without the participation of the wind turbines was carried out. Analysis and simulation results have shown possible improvements on closed loop performance, and computational burden with the physical constraints. Coordinated distributed MPC for LFC of power system with wind farms was proposed in Liu et al. (2017). Both simulation and experimental tests of a four-area interconnected power system LFC, which consists of thermal plants, hydro units, and a wind farm, demonstrate the improved efficiency of the coordinated DMPC. A new scheme for power system LFC to maintain the performance of the centralised MPC while keeping the reliability of the local PI controller was proposed in Liu et al. (2012). A hierarchical two-level optimal control strategy for the load frequency control of the multi-area power systems was presented. Distributed MPC strategies including application to LFC in the electrical network was proposed in Shiroei and Ranjbar (2014). The distributed approach framework realises the performance similar to centralised MPC. Ma et al. (2014) have presented a distributed model predictive LFC of multi-area interconnected power system. The dynamics model of multi-area interconnected was introduced and GRC and load reference set point constraint were considered.

Table 1 gives some MPC based LFC strategies. Two models based on decentralised models and on comparison of distributed and centralised MPC were presented in Mohamed et al. (2011) and Ojaghi and Rahmani (2017). Mohamed et al. (2011) have presented a decentralised MPC based LFC in an interconnected power system. The results have shown that considering the proposed predictive method the overall performance of the closed-loop technique has demonstrated robustness in the load disturbance condition. The performance of cooperatively distributed MPC is compared with that of the centralised MPC and the classical AGC methods was presented in Ojaghi and Rahmani (2017). The main contribution was that the load variations are applied to the system in the form of consecutive pulses.

Table 1
MPC based LFC strategies.

MPC LFC solutions		
MPC model	Areas	References
Distributed model based state variables	4	Shiroei et al. (2013b)
Distributed model based Simulink	2; 3 and 4	Zheng et al. (2017), Zhang et al. (2015)
Decentralised model based Simulink	3	Mohamed et al. (2011)
Nonlinear model based Simulink	2 and 3	Shiroei and Ranjbar (2014), Mohamed et al. (2011)
Predictive active control	2	Tungadio et al. (2018b)
Robust multivariable based Simulink	3	Liu et al. (2016b)
Supervisory MPC based Simulink	4	Zhao et al. (2016)
Bat inspired algorithm based Simulink	2	Elsisi et al. (2016)
Economic MPC based state variable	1	Sokoler et al. (2015)
Robust nonlinear based state variables	1	Ersdal et al. (2016b), Ersdal et al. (2016a)

4.3. Robust MPC

Taking into account the time delays or time varying in communication network and the uncertainties of parameters the authors in Venkat et al. (2008) have presented a robust predictive LFC. The goal of their research was achieved by a good performance of the closed-loop control system, considering the practical problems of the power system network. Shiroei et al. (2013b) have proposed a MPC for power grid LFC when considering the imbalance uncertainty. Based on the simulations performed on the power system with a high number of wind generation integrated, it was shown that in certain cases in which the state of the art LFC applying PI controller and normal MPC have failed by violating the constraints of the system while the robust MPC fulfils all these constraints. Liu et al. (2016b) have proposed a robust predictive control model based LFC taking into account the generation limit constraints. The authors took into account the uncertainty and parameter variations and the proposed model was robust. Robust distributed MPC for LFC of uncertain power systems was introduced in Liu et al. (2016b). The proposed algorithm solved a series of local convex optimisation problems to minimise an attractive range for a robust performance objective by using a time-varying state-feedback controller for each control area.

5. Summary and future work

5.1. Summary

- The present paper reviews the comprehensive literature concerning the load frequency controller models. The recent issues and challenges faced by these controllers as well as by the power system in order to maintain the frequency of the system to nominal values and to maintain the voltage and active power profile within predetermined limits are also addressed in this paper.
- The integration of fluctuating energy sources like solar and wind power with energy storage devices improve the reliability of the system as well as the quality of power delivered to the consumers. The frequency control is a major issue in the power system operation and control and lot of advanced control strategies have been developed over the last decades in order to improve the frequency control of the power system. Therefore, further efforts are required to design frequency control strategies which can take into account the dynamics of microgrids if these are grid connected.
- The frequency control is a major issue in the power system operation and control and lot of advanced control strategies have been developed over the last decades in order to improve the frequency control of the power system. However, there is a growing trend to develop microgrids which may be operated in grid connected or isolated mode. The microgrids essentially have unpredictable renewable

sources of energy besides storage. Therefore, further efforts are required to design frequency control strategies which can take into account the dynamics of microgrids if they are grid connected.

- The growing penetration of the renewable energy resources into the power system is also a point of concern for frequency control of the power system design and operation. The existing frequency control problem does not take into account the renewable sources of energy such as wind and solar power, etc. Till date most of the renewable energy sources integrated into the power system do not participate in frequency control of the power system. However, with growing penetration of such sources, their dynamic participation in the design of frequency control of the power system needs to be explored.
- In practice the conventional control strategies, such as PI and PID algorithms are the most applied for load frequency control in power system plant. When taking into account the external disturbances in the power system, the conventional controllers could not guarantee a good performance. Numbers of controllers are proposed and can be found in the literature. The weakness of most of them can be summarised by the conventional controllers applied to the nonlinear system, most of the time there are dependent on the mathematical model of the plant. Various disturbances can be added to these drawbacks: uncertainty based on load power variation, error, modelling and various modification of network physical structure. Taking into account drawbacks, integration of renewable energy sources in the network and all the structure modification that happen in the modern power system, it is become beneficial to introduce new control models.

5.2. Future scope

- The integration of fluctuating energy sources like solar and wind power with energy storage devices improve the reliability of the system as well as the quality of power delivered to the consumers. The frequency control is a major issue in the power system operation and control and lot of advanced control strategies have been developed over the last decades in order to improve the frequency control of the power system. Therefore, further efforts are required to design frequency control strategies which can take into account the dynamics of microgrids if these are grid connected.
- The growing penetration of the RER is also a point of concern for frequency control of the power system design and operation. The existing frequency control problem does not take into account the renewable sources of energy such as wind and solar power, etc. Till date solar energy sources do not participate in frequency control of the power system. However, with growing penetration of such sources, their dynamic participation in the design of frequency control of the power system needs to be explored.

Acknowledgment

This research is supported partially by South African National Research Foundation Grants (No. 112108 and 112142), and South African National Research Foundation Incentive Grant (No. 95687), Eskom Tertiary Education Support Programme, Research Grant from URC of University of Johannesburg. Faculty of Engineering and the Built of Environment, Department of Electrical and Electronic Engineering, Auckland Park Kingsway Campus, Johannesburg, South Africa.

References

- Abazari, A., Dozein, M.G., Monsef, H., 2018. An optimal fuzzy-logic based frequency control strategy in a high wind penetrated power system. *J. Franklin Inst. B* 355, 6262–6268.
- Abdelaziz, A.Y., Ali, E.S., 2016. Load frequency controller design via artificial cuckoo search algorithm. *Electr. Power Compon. Syst.* 44 (1), 90–98.
- Abdenour, A., 2002. Adaptive optimal gain scheduling for the load frequency control problem. *Electr. Power Compon. Syst.* 30 (1), 45–56.
- Aditiya, S.K., Das, D., 2003. Design of load frequency controllers using genetic algorithm for two area interconnected hydropower system. *Electr. Power Compon. Syst.* 31, 81–94.
- Aditya, S.K., Das, D., 2001. Battery energy storage or load frequency control of an interconnected power system. *Electr. Power Syst. Res.* 58, 179–185.
- Ahmadi, A., Aldeen, M., 2017. Robust overlapping load frequency output feedback control of multi-area interconnected power systems. *Int. J. Electr. Power Energy Syst.* 89, 156–172.
- Ahmadi, S., Shokoohi, S., Bevrani, H., 2015. A fuzzy logic-based droop control for simultaneous voltage and frequency regulation in an AC microgrid. *Int. J. Electr. Power Energy Syst.* 64, 148–155.
- Al-Hamouz, Z.M., Al-Duwaish, H.N., 2000. A new load frequency variable structure controller using genetic algorithms. *Electr. Power Syst. Res.* 55, 1–6.
- Al-Hamouz, Z.M., Magid, Y.L.A., 1993. Variable structure load frequency controllers for multi-area power systems. *Int. J. Electr. Power Energy Syst.* 15 (5), 293–300.
- Ali, E.S., Abd-Elazim, S.M., 2013. BFOA Based design of PID controller for two area load frequency control with nonlinearities. *Int. J. Electr. Power Energy Syst.* 51, 224–231.
- Alrifai, M.T., Hassan, M.F., Zribi, M., 2011. Decentralised load frequency controller for a multi-area interconnected power system. *Renew. Sustain. Energy Rev.* 33, 198–229.
- Aly, G., Magid, Y.L.A., Wali, M.A., 1984. Load frequency control of interconnected power systems via minimum variance regulators. *Electr. Power Syst. Res.* 7, 1–11.
- Anwar, Md.N., Pan, S., 2015. A new PID load frequency controller design method in frequency domain through direct synthesis approach. *Int. J. Electr. Power Energy Syst.* 67, 560–569.
- Arbolea, P., Diaz, D., Guerrero, J.M., Garcia, P., Briz, F., Moran, C.G., Aleixandre, J.G., 2010. An improved control scheme based in droop characteristics for microgrid converters. *Electr. Power Syst. Res.* 80, 1215–1221.
- Arya, Y., 2019. AGC Of PV- thermal and hydro thermal power systems using CES and a new multi stage FPIDF (1+PI) controller. *Renew. Energy* 134, 796–806.
- Arya, Y., Kumar, N., 2016. Fuzzy Gain scheduling controllers for automatic generation control of two-area interconnected electrical power systems. *Electr. Power Compon. Syst.* 44 (7), 737–751.
- Azeer, S.A., Ballgobin, R.R., Hassen, S.Z.S., 2017. Intelligent controllers for load frequency control of two-area power system. *IFAC PapersOnLine* 50 (2), 301–306.
- Aziz, A., Than-Oo, A., Stojcevski, A., 2018. Analysis of frequency sensitive wind plant penetration effect on load frequency control of hybrid power system. *Int. J. Electr. Power Energy Syst.* 99, 603–617.
- Bakirtzis, A.G., Thecharis, M.J.B., Kiartzis, M.S.J., Satsios, K.J., 1995. Short term load forecasting using fuzzy neural networks. *IEEE Trans. Power Syst.* 10 (3), 1518–1524.
- Bao, Y.Q., Li, Y., Wang, B., Hu, M., Chen, P., 2017. Demand response for frequency control for multi-area power system. *J. Mod. Power Syst. Clean Energy* 5 (1), 20–29.
- Barisal, A.K., 2015. Comparative analysis of teaching learning based optimisation of automatic load frequency control of multi-source powers systems. *Renew. Sustain. Energy Rev.* 66, 67–77.
- Barisall, A.K., Mishra, S., 2018. Improved PSO based automatic generation control of multi-source nonlinear power systems interconnected by AC/DC links. *Cogent Eng.* 5, 1–20.
- Bernard, M.Z., Mohamed, T.H., Qudaih, Y.S., Mitani, Y., 2014. Decentralised load frequency control in an interconnected power system using coefficient diagram method. *Int. J. Electr. Power Energy Syst.* 63, 165–172.
- Bevrani, H., Habibi, F., Babahajyani, P., Watanabe, M., Mitani, Y., 2012. Intelligent frequency control in AC microgrid: Online PSO-based fuzzy tuning approach. *IEEE Trans. Smart Grid* 3 (4), 1935–1944.
- Bevrani, H., Hiayama, T., 2007. Robust load frequency regulation: a real time laboratory experiment. *Optim. Control Appl. Meth.* 28, 419–433.
- Bevrani, H., Mitani, Y., Tsuji, K., 2004. Robust decentralised load frequency control using an iterative linear matrix inequalities algorithm. *IEEE Proc. Gener. Transm. Distrib.* 151 (3), 347–354.
- Bhatt, P., Roy, R., Ghoshal, S.P., 2011. Comparative performance evaluation of SMES-SMES, TCPS-SMES and SSSC-SMES controllers in automatic generation control for two area hydro-hydro system. *Int. J. Electr. Power Energy Syst.* 33, 1585–1597.
- Branco, H., Castro, R., Lopes, A.S., 2018. Battery energy storage systems as a way to integrate renewable energy in small isolated power systems. *Energy Sustain. Dev.* 43, 90–99.
- Cam, E., 2007. Application of fuzzy logic for load frequency control of hydroelectrical power plants. *Energy Convers. Manage.* 48, 1281–1288.
- Cam, E., Kocaarslan, I., 2005. Load frequency control in two area power systems using fuzzy logic controller. *Energy Convers. Manage.* 46, 233–243.
- Cardoso, G., Brouhard, T., DeForest, N., Wang, D., Helono, M., Kotzur, L., 2018. Battery aging in multi energy microgrid design using mixed integer linear programming. *Appl. Energy* 231, 1059–1069.
- Chandrakala, V., Sukumar, B., Sankaranarayan, K., 2014. Load frequency control of multi-source multi-area hydro thermal system using flexible alternating current transmission system devices. *Electr. Power Compon. Syst.* 42 (9), 927–934.
- Chang, C.S., Fu, W., Wen, F., 1998. Load frequency control using genetic algorithm based fuzzy gain scheduling of PI controllers. *Electr. Power Compon. Syst.* 26 (1), 39–52.
- Chapaloglou, S., Nesladi, A., Iliadis, P., Atsonlos, K., Nikolopoulos, N., Grammelis, P., Ylakkopoulos, C., Antoniadis, I., Kakaras, E., 2019. Smart energy management algorithm for load smoothing and peak shaving based on load forecasting of an island's power system. *Appl. Energy* 238, 627–643.
- Chaturvedi, D.K., Umrao, R., Malik, O.P., 2015. Adaptive polar fuzzy based load frequency controller. *Int. J. Electr. Power Energy Syst.* 66, 154–159.
- Chen, H., Ye, R., Wang, X., Lu, R., 2015. Cooperative control of power system load and frequency by using differential games. *IEEE Trans. Control Syst. Technol.* 23 (3), 882–897.
- Chidambaram, I.A., Paramasivm, B., 2012. Control performance standards based load frequency controller considering redox flow batteries coordinate with interline power flow controller. *J. Power Sources* 219, 292–304.
- Chidambaram, I.A., Velusami, S., 2005. Design of decentralised biased controllers for load frequency control of interconnected power systems. *Electr. Power Compon. Syst.* 33, 1313–1331.
- Colbertaldo, P., Agustin, S.B., Campanari, S., 2019. Impact of hydrogen energy storage on California electric power system: Towards 100% renewable electricity. *Int. J. Hydrogen Energy* 44, 9558–9576.
- Cui, Y., Xu, L., Fei, M., Shen, Y., 2017. Observer based robust integral sliding mode load frequency control for wind power systems. *Control Eng. Pract.* 65, 1–10.
- Daneshfar, F., Bevrani, H., 2012. Multiobjective design of load frequency control using genetic algorithms. *Int. J. Electr. Power Energy Syst.* 42, 257–263.
- Dash, P., Saika, L.C., Das, S.K., 2014. AGC of a multi-area hydrothermal system with BES and firefly optimised PID controller. In: *IEEE Eighteenth National Power Systems Conferences (NPSC)*, 2014, pp. 1–6.
- Debbarma, S., Saikia, L.C., Sinha, N., 2014. Automatic generation control using two degree of freedom fractional order PID controller. *Int. J. Electr. Power Energy Syst.* 58, 120–129.
- Delassi, A., Arif, S., Mokrani, L., 2018. Load frequency control problem in interconnected power systems using robust fractional PID controller. *Ain Shams Eng. J.* 9, 77–88.
- Demirelli, A., Yesil, E., 2004. Automatic generation control with fuzzy logic controllers in the power system including smes units. *Electr. Power Energy Syst.* 26, 291–305.
- Després, J., Mima, S., Kitous, A., Criqui, P., Hadjsaid, N., Noirot, I., 2017. Storage as a flexibility option in power systems with high shares of variable renewable energy sources: a poles-based analysis. *Energy Econ.* 64, 638–650.
- Devi, P.S., Santhi, R.V., Pushpalatha, D.V., 2016. Introducing LQR-fuzzy technique with dynamic demand response control loop to load frequency control model. *IFAC-PapersOnLine* 49 (1), 567–572.
- Dey, R., Ghosh, S., Ray, G., Rakshit, A., 2012. H_∞ Load frequency control of interconnected power systems with communication delays. *Int. J. Electr. Power Energy Syst.* 42, 672–684.
- Dhillon, S.S., Lather, J.S., Marwaha, S., 2015. Multi area load frequency control using particle swarm optimisation and fuzzy rules. *Procedia Comput. Sci.* 57, 460–472.
- Dhundhara, S., Verma, Y.P., 2018. CaPacitive energy storage with optimised controller for frequency regulation in realistic multisource deregulated power system. *Energy* 147, 1108–1128.

- Doolla, S., Bhatti, T.S., Bansal, R.C., 2011. Load frequency control of an isolated small hydro power plant using multi pipe scheme. *Electr. Power Compon. Syst.* 39 (1), 46–63.
- Dou, C.X., Liu, D.L., Jia, X.B., Zhao, F., 2011. Management and control for smart microgrid based on hybrid control theory. *Electr. Power Compon. Syst.* 39 (8), 813–832.
- Dzobo, O., Sun, Y., 2019. Optimal power control strategy of hybrid energy system considering demand response strategy and customer interruption cost. *Recent Adv. Electr. Electron. Eng.* 12, 20–29.
- Elazim, S.M.A., Ali, E.S., 2016. Load frequency controller design via BAT algorithm for nonlinear interconnected power system. *Int. J. Electr. Power Energy Syst.* 77, 166–177.
- Elgerd, O.I., Foshia, C.E., 1970. Optimum megawatt-frequency control of multi-area electric energy systems. *IEEE Trans. Power Appar. Syst.* 89 (4), 556–563.
- Elsisi, M., Soliman, M., Aboelela, M.A.S., Mansour, W., 2017. Optimal design of model predictive control with superconducting magnetic energy storage for load frequency control of nonlinear hydrothermal power system using bat inspired algorithm. *J. Energy Storage* 12, 311–318.
- Elsisi, M., Soliman, M., Aboelela, M.A.S., Mansour, W., 2016. Bat inspired algorithm based optimal design of model predictive load frequency control. *Int. J. Electr. Power Energy Syst.* 83, 426–433.
- Ersdal, A.M., Imsland, L., Uhlen, K., 2016a. Model predictive load frequency control. *IEEE Trans. Power Syst.* 31 (1), 777–785.
- Ersdal, A.M., Imsland, L., Uhlen, K., Fazozi, D., Thornhill, N.F., 2016b. Model predictive load frequency control taking into account imbalance uncertainty. *Control Eng. Pract.* 53, 139–150.
- Essiet, I.O., Sun, Y., Wang, Z., 2019. Optimised energy consumption model for smart home using improved differential evolution algorithm. *Energy* 172, 354–365.
- Falahati, S., Taher, S.A., Shahidehpour, M., 2016. A new smart charging method for EVs for frequency control of smart grid. *Int. J. Electr. Power Energy Syst.* 83, 458–469.
- Farhangi, R., Boroushaki, M., Hosseini, S.H., 2012. Load-frequency control of interconnected power system using emotional learning-based intelligent controller. *Int. J. Electr. Power Energy Syst.* 36, 76–83.
- Fathima, A.P., Khan, M.A., 2008. Design of a new market structure and robust controller for the frequency regulation service in the deregulated power system. *Electr. Power Compon. Syst.* 36, 864–883.
- Fattahi, J., Schriemer, H., Bacque, B., Orr, R., Hinzer, K., 2016. High stability adaptive microgrid control method using fuzzy logic. *Sustainable Cities Soc.* 25, 57–64.
- Fu, Q., Nasiri, A., Solanki, A., Ahmed, A.B., Weber, L., Bhavaraju, V., 2015. Microgrids: architecture, controls, protection and demonstration. *Electr. Power Compon. Syst.* 43 (12), 1453–1465.
- Fujimoto, K., Ota, T., Shimizu, Y., Ichikawa, T., Yukita, K., Goto, Y., Ichiyangi, K., Takeda, T., Hirose, K., Okui, Y., 2009. Load frequency control using storage system for microgrid. In: *Conference IEEE T & D, Asia*, pp. 1–4.
- Ghoshal, S.P., 2004. Application of GA/GA-SA based fuzzy automatic generation control of a multi-area thermal generating system. *Electr. Power Syst. Res.* 70, 115–127.
- Gonzalez, W.G., Montoya, O.D., Garcés, A., 2018. Control of a SMES for mitigating sub-synchronous oscillations in power systems: a PBC-PI approach. *J. Energy Storage* 20, 163–172.
- Gorripotu, T.S., Sahu, R.K., Panda, S., 2015. AGC Of a multi-area power system under deregulated environment using redox flow batteries and interline power flow controller. *Eng. Sci. Technol. Int. J.* 18, 555–578.
- Goyal, M., Ghosh, A., 2016. Microgrids interconnection to support mutually during any contingency. *Sustain. Energy, Grids Netw.* 6, 100–108.
- Gozde, H., Taplamacioglu, M.C., Kocaarslan, I., 2012. Comparative performance analysis of artificial BEE colony algorithm in automatic generation control interconnected reheat thermal power system. *Int. J. Electr. Power Energy Syst.* 42, 167–178.
- Greenwood, D.M., Lim, K.Y., Patsios, C., Lyons, P.F., Y.S., Taylor, P.C., 2017. Frequency response services designed for energy storage. *Appl. Energy* 203, 115–127.
- Guha, D., Roy, P.K., Banerjee, S., 2016. Load frequency control of interconnected power system using grey wolf optimization. *Swarm Evol. Comput.* 27, 97–115.
- Guha, D., Roy, P.K., Banerjee, S., 2018. Optimal tuning of 3 degree of freedom proportional integral derivative controller for hybrid distributed power system using dragonfly algorithm. *Comput. Electr. Eng.* 72, 137–153.
- Hanwate, S.D., Hote, Y.V., 2018. Optimal PID design for load frequency control using QRAWCP approach. *IFAC PapersOnLine* 51 (4), 651–656.
- Hasan, N., Ibraheem, Ahmad, S., 2016. ABT Based load frequency control of interconnected power system. *Electr. Power Compon. Syst.* 44 (8), 853–863.
- Hilliard, T., Swan, L., Kavgić, M., Qin, Z., Lingras, P., 2016. Development of whole building model predictive control strategy for a LEED silver community college. *Energy Build.* 111, 224–232.
- Hossain, M.J., Mahmud, M.A., Milano, F., Bacha, S., Hably, A., 2015. Design of robust distributed control for interconnected microgrids. *IEEE Trans. Smart Grid* 7 (6), 2724–2735.
- Hu, J., Xu, Y., Cheng, K.W., Guerrero, J.M., 2018. A model predictive control strategy of PV-battery microgrid under variable power generations and load conditions. *Appl. Energy* 221, 195–203.
- Huang, Z., Ni, Y., Shen, C.M., Wu, F.F., Chen, S., Zhang, B., 2000. Application of unified power flow controller in interconnected power systems-modelling, interface, control strategy, and case study. *IEEE Trans. Power Syst.* 15 (2), 817–824.
- Huddar, A., Kulkarni, P.S., 2008. A robust method of tuning the feedback gains of a variable structure load frequency controller using genetic algorithm optimisation. *Electr. Power Compon. Syst.* 36, 1351–1368.
- Hung, D.Q., Mithulananthan, N., Bansal, R.C., 2014. Integration of PV and BES units in commercial distribution systems considering energy loss and voltage stability. *Appl. Energy* 113, 1162–1170.
- Jagatheesam, K., Anand, B., Omar, M., 2015. Design of proportional-integral-derivative controller using ant colony optimisation technique in multi-area automatic generation control. *Int. J. Electr. Eng. Inf.* 7 (4), 541–558.
- Jaleeli, N., Vanslyck, L.S., Ewart, D.N., Fink, L.H., Hoffmann, A.G., 1992. Understanding automatic generation control. *IEEE Trans. Power Syst.* 7 (3), 1106–1122.
- Jing, W., Lai, C.H., Wong, W.S.H., Wong, M.L.D., 2018. A comprehensive study of battery super-capacitor hybrid energy storage system for standalone PV power system in rural electrification. *Appl. Energy* 224, 340–256.
- Kang, N., Liao, Y., 2010. Contingency studies of a real power system and violation mitigation measures. *Int. Rev. Model. Simul.* 3 (5), 882–887.
- Kassem, A.M., 2010. Neural predictive controller of a two area load frequency control for interconnected power system. *Ain Shams Eng. J.* 1, 49–58.
- Kayalvizhi, S., Kumar, D.M.V., 2017. Load frequency control of an isolated microgrid using fuzzy adaptive model predictive control. *IEEE Access* 5, 16241–16251.
- Kazemi, M.H., Karrari, M., Menhaj, M.B., 2002. Decentralised robust adaptive-output feedback controller for power system load frequency control. *Electr. Eng.* 84, 75–83.
- Kennedy, T., Hoyt, S.M., Abell, C.F., 1988. Variable nonlinear tie-line frequency bias for interconnected systems control. *IEEE Trans. Power Syst.* 3 (3), 1244–1253.
- Kerdphol, T., Qudaih, Y., mitani, Y., 2016. Optimum battery energy storage system using PSO considering dynamic demand response for microgrids. *Int. J. Electr. Power Energy Syst.* 83, 58–66.
- Khalghani, M.R., Khooban, M.H., Moghaddam, E.M., Vafamand, N., Goodarzi, M., 2016. A self-tuning load frequency control strategy for microgrids: human brain emotional learning. *Int. J. Electr. Power Energy Syst.* 75, 311–319.
- Khalid, M., Savkin, A.V., 2012. An optimal operation of wind energy storage system for frequency control based on model predictive control. *Renew. Energy* 48, 127–132.
- Khederzadeh, M., Maleki, H., 2013. Frequency control of microgrids in autonomous mode by a novel control scheme based on droop characteristics. *Electr. Power Compon. Syst.* 41 (1), 16–30.
- Khederzadeh, M., Maleki, H., Asgharian, V., 2016. Frequency control improvement of two adjacent microgrids in autonomous mode using back to back voltage-sourced converters. *Int. J. Electr. Power Energy Syst.* 74, 126–133.
- Khezri, R., Golshannavaz, S., Shokoohi, S., Bevrani, H., 2016. Fuzzy Logic based fine-tuning approach for robust load frequency control in a multi-area power system. *Electr. Power Compon. Syst.* 44 (18), 2073–2083.
- Khezri, R., Oshnoei, A., Oshnoei, S., Bevrani, H., Muyeen, S.M., 2019. An intelligent coordinator design for GCSC and AGC in two area hybrid power system. *Appl. Soft Comput.* 76, 491–504.
- Khodabakhshian, A., Edrisi, M., 2008. A new robust PID load frequency controller. *Control Eng. Pract.* 16, 1069–1080.
- Khodabakhshian, A., Hooshmand, R., 2010. A new PID controller design for automatic generation control of hydropower system. *Int. J. Electr. Power Energy Syst.* 32, 375–382.
- Khodabakhshian, A., Pour, M.E., Hooshmand, R., 2012. Design of a robust load frequency control using sequential quadratic programming technique. *Int. J. Electr. Power Energy Syst.* 40, 1–8.
- Khooban, M.H., Niknam, T., 2015. A new intelligent online fuzzy tuning approach for multi-area load frequency control: Self adaptive modified bat algorithm. *Int. J. Electr. Power Energy Syst.* 71, 254–261.
- Khooban, M.H., Niknam, T., Blaabjerg, F., Davari, P., Dragicevic, T., 2016a. A robust adaptive load frequency control for micro-grids. *ISA Trans.* 65, 220–229.
- Khooban, M.H., Niknam, T., Blaabjerg, F., Davari, P., Dragičević, T., 2016b. A robust adaptive load frequency control for microgrids. *ISA Trans.* 65, 20–229.
- Kocaarslan, I., Cam, E., 2005. Fuzzy Logic controller in interconnected electrical power systems for load-frequency control. *Int. J. Electr. Power Energy Syst.* 27, 542–549.
- Kothari, M.L., Nanda, J., Kothari, D.P., Das, D., 1989. Discrete mode automatic generation control of two area reheat thermal system with new area control error. *IEEE Trans. Power Syst.* 4 (2), 730–738.

- Krim, Y., Abbes, D., Krim, S., Mimouni, M.F., 2018. Intelligent droop control and power management of active generator for ancillary services under grid instability using fuzzy logic technology. *Control Eng. Pract.* 81, 215–230.
- Krishnan, R., Pragatheeswaran, J.K., Ray, G., 2017. Robust stability of networked load frequency control systems with time-varying delays. *Electr. Power Compon. Syst.* 45 (3), 302–314.
- Kumar, N.J.V., Ansari, M.M.T., 2016. A new design of dual mode type-II fuzzy logic load frequency controller for interconnected power systems with parallel AC-DC tie-lines and capacitor energy storage unit. *Int. J. Electr. Power Energy Syst.* 82, 579–598.
- Kumar, A., Malik, O.P., Hope, G.S., 1984. Power generation control using dual-mode control. *Mach. Power Syst.* 9, 335–345.
- Kumar, A., Malik, O.P., Hope, G.S., 1987. Discrete variable structure controller for load frequency control of multi-area interconnected power systems. *IET Proc.* 134 (2), 116–112.
- Kundur, P., 1994. *Power System Stability and Control*. McGraw-Hill, New York.
- Lee, H.J., Park, J.B., Joo, Y.H., 2006. Robust load frequency control for uncertain nonlinear power systems a fuzzy logic approach. *Inform. Sci.* 176, 3520–3537.
- Li, X., Song, Y.J., Han, S.B., 2008. Frequency control in microgrid power system combined with electrolyser system and fuzzy PI controller. *J. Power Sources* 180, 468–475.
- Liao, K., Xu, Y., 2017. A robust load frequency control scheme for power systems based on second-order sliding mode and extended disturbances observer. *IEEE Trans. Ind. Inf.* 14 (7), 3076–3086.
- Liu, X., Kong, X., Deng, X., 2012. Power system model predictive load frequency control. In: *Proc. American Control Conference, Fairmont Queen Elisabeth, Montréal, Canada, 27–29 June 2012*, pp. 6602–6607.
- Liu, X., Kong, X., Lee, K.Y., 2016a. Distributed model predictive control for load frequency control with dynamic fuzzy valve position modelling for hydro-thermal power system. *IET Control Theory Appl.* 10 (14), 1653–1664.
- Liu, X., Zhang, Y., Lee, K.Y., 2016b. Robust distributed MPC for load frequency control of uncertain power systems. *Control Eng. Pract.* 56, 136–147.
- Liu, X., Zhang, Y., Lee, K.Y., 2017. Coordinated distributed MPC for load frequency control of power system with wind farms. *IEEE Trans. Ind. Electron.* 64 (6), 5140–5150.
- Lu, C.F., Liu, C.C., Wu, C.J., 1995. Effect of battery energy storage system on load frequency control considering governor dead-band and generation rate constraint. *IEEE Trans. Energy Convers.* 10 (3), 555–561.
- Luo, Y., Shi, L., Tu, G., 2014. Optimal sizing and control strategy of isolated grid with wind power and energy storage system. *Energy Convers. Manage.* 80, 407–415.
- Ma, M., Chen, H., Liu, X., Allgower, F., 2014. Distributed model predictive load frequency control of multi-area interconnected power system. *Int. J. Electr. Power Energy Syst.* 62, 289–298.
- Ma, M., Zhang, C., Liu, X., Cheng, H., 2017. Distributed model predictive load frequency control of the multi-area power system after deregulation. *IEEE Trans. Ind. Electron.* 64 (6), 5129–5139.
- Magdy, G., Shabib, G., Elbaset, A.A., Mitani, Y., 2018. Frequency stabilisation of renewable power systems based on MPC with application to the Egyptian grid. *IFAC PaperOnLine* 51 (28), 280–285.
- Mahto, T., Mukherjee, V., 2017. A novel scaling factor based fuzzy logic controller for frequency control of an isolated hybrid power system. *Energy* 130, 339–350.
- Majumder, R., Ghosh, A., Ledwich, G., Zare, F., 2010. Load frequency control for rural distributed generation. *Electr. Power Compon. Syst.* 38 (6), 637–656.
- Maslo, K., Kolcun, M., 2014. Load frequency control management in island operation. *Electr. Power Syst. Res.* 114, 10–20.
- Mehrasa, M., Poursemaei, E., Jorgensen, B.N., Catalao, J.P.S., 2015. A control plan for the stable operation of microgrids during grid-connected and islanded modes. *Electr. Power Syst. Res.* 129, 10–22.
- Mi, Y., Fu, Y., Wang, C., Wang, P., 2013. Decentralised sliding mode load frequency control for multi-area power systems. *IEEE Trans. Power Syst.* 28 (4), 4301–4309.
- Minh, B.L.N., Huynh, V.V., Nguyen, T.M., Tsai, Y.W., 2018. Decentralised adaptive double integral mode controller for multi-area power systems. *Math. Probl. Eng.* 1–11. <http://dx.doi.org/10.1155/2018/2672436>.
- Mohamed, T.H., Bevrani, H., Hassan, A.A., Hiyama, T., 2011. Decentralized model predictive based load frequency control in an interconnected power system. *Energy Convers. Manage.* 52, 1208–1214.
- Mohamed, T.H., Morel, J., Bevrani, H., Hiyama, T., 2012. Model predictive based load frequency control based concerning wind turbines. *Int. J. Electr. Power Energy Syst.* 43, 859–867.
- Mohamed, T.H., Shabib, G., Ali, H., 2016. Distributed load frequency control in an interconnected power system using ecological and coefficient diagram method. *Int. J. Electr. Power Energy Syst.* 82, 496–507.
- Mohanty, B., Panda, S., Hota, P.K., 2014. Controller parameters tuning of differential evolution algorithm and its application to load frequency control of multi-source power system. *Int. J. Electr. Power Energy Syst.* 54, 77–85.
- Moradi, H., Esfahanian, M., Abtachi, A., Zilouchian, A., 2018. Optimisation and energy management of a standalone hybrid microgrid in the presence of battery storage system. *Energy* 147, 226–238.
- Morattab, A., Shafiee, Q., Bevrani, H., 2011. Decentralized model predictive load frequency control for deregulated power systems in tough situation. In: *Proc. IEEE PowerTech, 19–23 June, 2011, Trondheim, Norway*, pp. 1–5.
- Morsali, J., Zare, K., Hagh, M.T., 2018. Comparative performance evaluation of fractional orders controllers in LFC of two-area diverse unit power system with considering GDB and GRC effects. *J. Electr. Syst. Inf. Technol.* 5, 708–722.
- Mu, C., Tang, Y., He, H., 2017. Improved sliding mode design for load frequency control of power system integrated an adaptive learning strategy. *IEEE Trans. Ind. Electron.* 64 (8), 6742–6751.
- Mufti, M.U.D., Lone, S.A., Iqbal, S.J., Ahmad, M., Ismail, M., 2009. Super-capacitor based energy storage system for improved load frequency control. *Electr. Power Syst. Res.* 79, 226–233.
- Muyeen, S.M., Hasanien, H.M., Al-Durra, A., 2014. Transient stability enhancement of wind farms connected to a multi-machine power system by using an adaptive ANN-controlled SMES. *Energy Convers. Manage.* 78, 412–420.
- Muzhikyan, A., Farid, A.M., Toumi, K.Y., 2016. Relative merits of load following reserves and energy storage market integration towards power system imbalances. *Int. J. Electr. Power Energy Syst.* 74, 222–229.
- Nanda, J., Kothari, M.L., Satsangi, P.S., 1983. Automatic generation control of an interconnected hydrothermal system in continuous and discrete modes considering generation rate constraints. *IEE Proc. D Control Theory Appl.* 130 (1).
- Nandar, C.S.A., 2013. Robust PI control of smart controllable load frequency stabilisation of microgrid power system. *Renew. Energy* 56, 16–23.
- Nandar, C.S.A., 2016. Robust PI control of smart controllable load for frequency stabilisation of microgrid power system. *Renew. Energy* 56, 16–23.
- Nandi, M., Shiva, C.K., Mukherjee, V., 2017a. Frequency stabilisation of multi-area multi-source interconnected power system using TCSC and SMES mechanism. *J. Energy Storage* 14, 248–362.
- Nandi, M., Shiva, C.K., Mukherjee, V., 2017b. Frequency stabilisation of multi-area multi-source interconnected power system using TCSC and SMES mechanism. *J. Energy Storage* 14, 348–362.
- Ngamroo, I., Kongprawechnon, W., 2003. A robust controller design of SSSC for stabilisation of frequency oscillations in interconnected power systems. *Electr. Power Syst. Res.* 67, 161–176.
- Nikmehr, N., Ravadanegh, S.N., 2016. Reliability evaluation of multi-microgrids considering optimal operation of small scale energy zones under load-generation uncertainties. *Int. J. Electr. Power Energy Syst.* 78, 80–87.
- Obaid, Z.A., Cipcigan, L.M., Muhssin, M.T., 2016. Fuzzy Hierarchical approach-based optimal frequency control in the Great Britain power system. *Electr. Power Syst. Res.* 141, 529–537.
- Ojaghi, P., Rahmani, M., 2017. LMI-Based robust predictive load frequency control for power systems with communication delays. *IEEE Trans. Power Syst.* 32 (5), 4091–4100.
- Olivares, D.E., Sani, A.M., Etemadi, A.H., Canizares, C.A., Irvani, R., Kazerani, M., Hajimiragha, A.H., Bellmunt, O.G., Saadefard, M., Behnke, R.P., Estevez, G.A.J., Gyriou, N.D.H., 2014. Trends in microgrids control. *IEEE Trans. Smart Grid* 5 (4), 1905–1919.
- Padhan, S., Sahu, R.K., Panda, S., 2014. Automatic generation control with thyristors controlled series compensator including superconducting magnetic energy storage units. *Ain Shams Eng. J.* 5, 759–774.
- Panda, S., Yegireddy, N.K., 2013. Automatic generation control of multi-area power system using multi-objective non-dominated sorting genetic algorithm-II. *Int. J. Electr. Power Energy Syst.* 53, 54–63.
- Pandi, V.R., Al-Hinai, A., Feliachi, A., 2015. Coordinated control of distributed energy resources to support load frequency control. *Energy Convers. Manage.* 105, 918–928.
- Pappachen, A., Fathima, A.P., 2016. Load frequency control in deregulated power system integrated with SMES-TCPS combination using ANFIS controller. *Int. J. Electr. Power Energy Syst.* 82, 519–534.
- Parmar, K.P.S., Majhi, S., Kothari, D.P., 2012. Load frequency control of a realistic power system with multi-source power generation. *Int. J. Electr. Power Energy Syst.* 42, 426–433.
- Patra, S., Sen, S., Ray, G., 2007. Design of robust load frequency controller H_∞ loop shaping approach. *Electr. Power Compon. Syst.* 35, 769–783.
- Peng, C., Zhang, J., 2016. Delay-distribution-dependent load frequency control of power systems with probabilistic interval delays. *IEEE Trans. Power Syst.* 31 (4), 3309–3317.
- Pothiya, S., Ngamroo, I., 2008. Optimal fuzzy logic-based PID controller for load-frequency control including superconducting magnetic energy storage units. *Energy Convers. Manage.* 49, 2833–2838.
- Pradhan, P.C., Sahu, R.K., Panda, S., 2016. Firefly algorithm optimised fuzzy PID controller for AGC of multi-area multi-source power systems with UPFC and SMES. *Eng. Sci. Technol. Int. J.* 19, 338–354.
- Prakash, S., Sinha, S.K., 2014. Simulation based neuro fuzzy hybrid intelligent PI control approach in four-area load frequency control of interconnected power system. *Appl. Soft Comput.* 23, 152–164.

- Qian, D., Tong, S., Liu, H., Liu, X., 2016. Load frequency control by neural-network-based integral sliding mode for nonlinear power systems with wind turbines. *Neurocomputing* 173, 875–885.
- Ramakrishna, K.S.S., Bhatti, T.S., 2007. Sampled-data automatic load frequency control of a single area power system with multi-source power generation. *Electr. Power Compon. Syst.* 35 (8), 955–980.
- Ramesh, S., Krishnan, A., 2009. Modified genetic algorithm based load frequency controller for interconnected power systems. *Int. J. Electr. Power Eng.* 3 (1), 26–30.
- Ramirez, M., Castellanos, R., Calderon, G., Malik, O., 2018. Placement and sizing of battery energy storage for primary frequency control in an isolated section of the Mexican power system. *Electr. Power Syst. Res.* 160, 142–150.
- Ray, G., Dey, S., Bhattacharyya, T.K., 2005. Multi-area load frequency control of power systems: a decentralised variable structure approach. *Electr. Power Compon. Syst.* 33, 315–331.
- Rerkpreedapong, D., Hasanovic, A., Feliachi, A., 2003. Robust load frequency control using genetic algorithms and linear matrix inequalities. *IEEE Trans. Power Syst.* 18 (2), 855–861.
- Rout, U.K., Sahu, R.K., Panda, S., 2013. Design and analysis of differential evolution algorithm based automatic generation control for interconnected power system. *Ain Shams Eng. J.* 4, 409–421.
- Sabahi, K., Ghaemi, S., Badamchizadeh, M., 2016. Designing an adaptive Type-2 fuzzy logic system load frequency control for a nonlinear time-delays power system. *Appl. Soft Comput.* 43, 97–106.
- Sahoo, B.P., Panda, S., 2018. Improved grey wolf optimisation technique for fuzzy aided PID controller design for power system frequency control. *Sustain. Energy, Grids Netw.* 16, 278–299.
- Sahu, R.K., Gorripotu, T.S., Panda, S., 2015a. A hybrid DE-PS algorithm for load frequency control under deregulated power system with UPFC and RFB. *Ain Shams Eng. J.* 6, 893–911.
- Sahu, R.K., Gorripotu, T.S., Panda, S., 2016a. Automatic generation control of multi-area power with divers energy sources using teaching learning based optimisation algorithm. *Int. J. Eng. Sci. Technol.* 19, 113–134.
- Sahu, R.K., Panda, S., Padhan, S., 2015b. A hybrid firefly algorithm and pattern search technique for automatic generation control of multi-area power systems. *Int. J. Electr. Power Energy Syst.* 64, 9–23.
- Sahu, R.K., Panda, S., Rout, U.K., 2013. DE Optimized parallel 2-DOF PID controller for load frequency control of power system with governor dead-band nonlinearity. *Int. J. Electr. Power Energy Syst.* 49, 19–33.
- Sahu, R.K., Panda, S., Sekhar, G.T.C., 2015c. A novel hybrid PSO-PS optimised fuzzy PI controller for AGC in multi area interconnected power systems. *Int. J. Electr. Power Energy Syst.* 64, 880–893.
- Sahu, R.K., Panda, S., Yegireddy, N.K., 2014. A novel hybrid DEPS optimised fuzzy PI/PID controller for load frequency control of multi-area interconnected power systems. *Energy Convers. Manage.* 24, 1596–1608.
- Sahu, B.K., Pati, S., Mohanty, P.K., Panda, S., 2015. Teaching-learning based optimisation algorithm based fuzzy-pid controller for automatic generation control of multi-area power system. *Appl. Soft Comput.* 27, 240–249.
- Sahu, B.K., Pati, T.K., Nayak, J.R., Panda, S., Kar, S.K., 2016b. A novel hybrid LUS-TLBO optimised fuzzy-PID controller for frequency control of multi-source power system. *Int. J. Electr. Power Energy Syst.* 74, 58–69.
- Sathya, M.R., Ansari, M.M.T., 2015. Load frequency control using BAT inspired algorithm based dual mode gain scheduling of PI controllers for interconnected power system. *Int. J. Electr. Power Energy Syst.* 64, 365–374.
- Sathya, M.R., Ansira, M.M.T., 2016. Design of biogeography optimisation based dual gain scheduling of fractional order PI load frequency controllers for multi-source interconnected power systems. *Int. J. Electr. Power Energy Syst.* 83, 364–381.
- Saxena, S., Hote, Y.V., 2016. Decentralized PID load frequency control for perturbed multi-area power systems. *Int. J. Electr. Power Energy Syst.* 81, 405–415.
- Sekhar, G.T.C., Sahu, R.K., Baliarsingh, A.K., Panda, S., 2016. Load frequency control of power system under deregulated environment using optimal firefly algorithm. *Int. J. Electr. Power Energy Syst.* 74, 195–211.
- Selvaraju, R.K., Somaskandan, G., 2016. Impact of energy storage units on load frequency control of deregulated power systems. *Energy* 97, 214–228.
- Shabani, H., Vahidi, B., Ebrahimipour, M., 2013. A robust PID controller based on imperialist competition algorithm for load frequency control of power systems. *ISA Trans.* 52, 88–95.
- Shankar, R., Bhushan, R., Chatterjee, K., 2016a. Small-signal stability analysis for two area interconnected power system with load frequency controller in coordination with FACTS and energy storage device. *Ain Shams Eng. J.* 7, 603–612.
- Shankar, R., Chatterjee, K., Bhushan, R., 2016b. Impact of energy storage system on load frequency control for diverse sources of interconnected power system in deregulated power environment. *Int. J. Electr. Power Energy Syst.* 79, 11–26.
- Sharma, G., Nasiruddin, I., Niazi, K.R., Bansal, R.C., 2016. Optimal AGC of a multi-area power system with parallel AC/DC tie lines using output vector feedback control strategy. *Int. J. Electr. Power Energy Syst.* 81, 22–31.
- Shayaghi, H., Jalili, A., Shayanfar, H.A., 2008. Multi-stage fuzzyload frequency control using PSO. *Energy Convers. Manage.* 49, 2570–2580.
- Shayeghi, H., Jalili, A., Shayanfar, H.A., 2008. Multi-stage fuzzy frequency control using PSO. *Energy Convers. Manage.* 49, 2570–2580.
- Shiroei, M., Ranjbar, A.M., 2014. Supervisory predictive control of power system load frequency control. *Int. J. Electr. Power Energy Syst.* 61, 70–80.
- Shiroei, M., Ranjbar, A.M., Amraee, T., 2013a. A functional model predictive control approach for power system load frequency control considering generation rate constraint. *Int. Trans. Electr. Eng. Syst.* 23, 214–229.
- Shiroei, M., Toulabi, M.R., Ranjbar, A.M., 2013b. Robust multivariable predictive based load frequency control considering generation rate constraint. *Int. J. Electr. Power Energy Syst.* 46, 406–413.
- Shiva, C.K., Mukherjee, V., 2016. A novel quasi-oppositional harmony search algorithm for AGC optimisation on three-area multi-unit power system after deregulation. *Int. J. Eng. Sci. Technol.* 19, 395–420.
- Singh, V.P., Mohanty, S.R., Kishor, N., Ray, P.K., 2013. Robust H-infinity load frequency control in hybrid distributed generation system. *Int. J. Electr. Power Energy Syst.* 46, 294–305.
- Sokoler, L.E., Edlund, K., Jorgensen, J.B., 2015. Application of economic MPC to frequency control in single area power system. In: *Proc. IEEE 54th Conference on Decision and Control (CDC 2015)*, 15–18 December, 2015, Osaka, Japan, pp. 2635–2642.
- Son, Y., Li, N., Zhao, X., Wei, Z., Sun, G., Huang, C., 2016. Robust H_∞ load frequency control of delayed multi-area power system with stochastic disturbances. *Neurocomputing* 193, 58–67.
- Sondhi, S., Hote, Y.V., 2016. Fractional order PID controller for perturbed load frequency control using Kharitonov's theorem. *Int. J. Electr. Power Energy Syst.* 78, 884–896.
- Sudha, K.R., Raju, Y.B., Sekhar, A.C., 2016. Fuzzy C-Means clustering for robust decentralised load frequency control of interconnected power system with generation rate constraint. *Int. J. Electr. Power Energy Syst.* 37, 58–66.
- Sudha, K.R., Santhi, R.V., 2011a. Robust decentralised load frequency control of interconnected power system with generation rate constraint using Type-2 fuzzy approach. *Int. J. Electr. Power Energy Syst.* 33, 699–707.
- Sudha, K.R., Santhi, R.V., 2011b. Robust decentralised load frequency control of interconnected power system with generation rate constraint using Type-2 fuzzy approach. *Int. J. Electr. Power Energy Syst.* 33 (3), 699–707.
- Sudha, K.R., Santhi, R.V., 2012. Load frequency control of an interconnected reheat thermal system using Type-2 fuzzy system including SMES units. *Int. J. Electr. Power Energy Syst.* 43, 1383–1392.
- Sun, Y., Li, N., Zhao, X., Wei, Z., Sun, G., Huang, C., 2016. Robust H_∞ load frequency control of delayed multi-area power with stochastic disturbances. *Neurocomputing* 193, 58–67.
- T, Fathima, A.P., 2018. NERC's control performance standards based load frequency controller for a multi-area deregulated power system with ANFIS approach. *Ain Shams Eng. J.* 9, 2399–2414.
- Taher, S.A., Fini, M.H., Aliabadi, S.F., 2014. Fractional order PID controller design for LFC in electric power systems using imperialist competitive algorithm. *Ain Shams Eng. J.* 5, 121–135.
- Talaq, J., Al-Basri, F., 1999. Adaptive Fuzzy gain scheduling for load frequency control. *IEEE Trans. Power Syst.* 14 (1), 145–150.
- Tan, W., Xu, Z., 2009. Robust analysis and design of load frequency controller for power systems. *Electr. Power Syst. Res.* 79, 846–853.
- Tan, W., Zhang, H., Yu, M., 2012. Decentralised load frequency control in deregulated environments. *Int. J. Electr. Power Energy Syst.* 41, 16–26.
- Tan, W., Zhou, H., 2012. Robust analysis of decentralised load frequency control for multi-area power systems. *Int. J. Electr. Power Energy Syst.* 43, 996–1005.
- Thao, N.G.M., Uchida, K., 2017. A two-level control strategy with fuzzy logic for large scale photovoltaic farms to support grid frequency regulation. *Control Eng. Pract.* 59, 77–99.
- Thirunavukarasu, R., Chidambaram, I.A., 2016. Pi^2 controlled based coordinated control with redox flow battery and unified power flow controller for improved restoration indices in a deregulated power system. *Ain Shams Eng. J.* 7, 1011–1027.
- Toulabi, M.R., Shiroei, M., Ranjbar, A.M., 2014. Robust analysis and design of power system load frequency control using the Kharitonov's theorem. *Int. J. Electr. Power Energy Syst.* 55, 51–58.
- Tripathy, S.C., Balasubramanian, R., Nair, P.S.C., 1992. Adaptive automatic generation control with superconducting magnetic energy storage in power systems. *IEEE Trans. Energy Convers.* 7 (3), 434–441.
- Tripathy, S.C., Hope, G.S., Malik, O.P., 1982a. Optimisation of load frequency control parameters for power systems with reheat steam turbines and governor dead band nonlinearity. *IET Proc. D. Control Theory Appl.* 129 (1).
- Tripathy, S.C., Hope, G.S., Malik, O.P., 1982b. Optimisation of load frequency control parameters for power systems with reheat steam turbines and governor dead-band nonlinearity. *IET Proc.* 129 (1).
- Tsay, T.S., 2011. Load frequency control of interconnected power system with governor backlash nonlinearities. *Int. J. Electr. Power Energy Syst.* 33, 1542–1549.
- Tungadio, D.H., 2018. Optimal Active Power Control of Microgrids Interconnected to a Power System (Ph.D. thesis), University of Pretoria.

- Tungadio, D.H., Bansal, R.C., 2017. Active power reserve estimation of two interconnected microgrids. *Energy Procedia* 105, 3909–3914.
- Tungadio, D.H., Bansal, R.C., Siti, M.W., 2017. Optimal control of active power of two microgrids interconnected with two ac tie-lines. *Electr. Power Compon. Syst.* 45 (19), 2188–2199.
- Tungadio, D.H., Bansal, R.C., Siti, M.W., 2018a. Energy flow estimation-control of two interconnected microgrids. *J. Energy South. Afr.* 29 (4), 69–80.
- Tungadio, D.H., Bansal, R.C., Siti, M.W., Mbungu, N.T., 2018b. Predictive active power control of two interconnected microgrids. *Technol. Econ. Smart Grids Sustain. Energy* 3 (3), 1–15.
- Velusami, S., Chidambaram, A.I., 2006. Design of decentralised biased dual mode controllers for load frequency control of interconnected power systems. *Electr. Power Compon. Syst.* 34, 1057–1075.
- Velusami, S., Chidambaram, A.I., 2007. Decentralised biased dual mode controllers for load frequency control of interconnected power systems considering GDB and GRC non-linearities. *Energy Convers. Manage.* 48, 1691–1702.
- Venkat, A.N., Hiskens, I.A., Rawlings, J.B., Wright, S.J., 2008. Distributed MPC strategies with application to power system automatic generation control. *IEEE Trans. Control Syst. Technol.* 16 (6), 1192–1206.
- Vigneysh, T., Kumarappan, N., 2016. Autonomous operation and control of photovoltaic/ solid oxide fuel cell/battery energy storage based microgrid using fuzzy logic controller. *Int. J. Hydrogen Energy* 41, 1877–1891.
- Vrdoljak, K., Peric, N., Petrovic, I., 2010. Sliding mode based load frequency control in power systems. *Electr. Power Syst. Res.* 80, 514–527.
- Wang, L., 2009. *Model Predictive Control System Design and Implementation using Matlab*. Springer, London.
- Wang, R., Zhang, X., Bao, J., 2019. A self-interested distributed economic model predictive control approach to battery energy storage networks. *J. Process Control* 73, 9–18.
- Xiangping, M., Xiangyin, M., Dayou, L., Wanyu, T., 2001. Fuzzy sliding mode load frequency control of multi-area interconnected power systems. In: *IFAC Conference on New Technologies for Computer Control*, 19–25 2001, Hong Kong, pp. 452–457.
- Xiong, L., Li, H., Wang, J., 2018. LMI Based robust load frequency control for time delayed power system via delay margin estimation. *Int. J. Electr. Power Energy Syst.* 100, 91–103.
- Yang, T.C., Ding, Z.T., Yu, H., 2002. Decentralised power system load frequency control beyond the limit of diagonal dominance. *Int. J. Electr. Power Energy Syst.* 24, 173–184.
- yang, S., Huang, C., Yu, Y., Yue, D., Xie, J., 2017. Load frequency control of interconnected power system via multi-agent system method. *Electr. Power Compon. Syst.* 45 (8), 839–851.
- Yazdizadeh, A., Ramezani, M.H., Hamedrahmat, E., 2012. Decentralised load frequency control using a new robust optimal MISO PID controller. *Int. J. Electr. Power Energy Syst.* 35, 57–65.
- Yesil, E., Guzelkaya, M., Eksin, I., 2004. Self-tuning fuzzy PID type load and frequency controller. *Energy Convers. Manage.* 45, 377–390.
- Yousef, H., 2015. Adaptive fuzzy logic load frequency control of multi-area power system. *Int. J. Electr. Power Energy Syst.* 68, 384–395.
- Yousef, H.A., Al-Kharusi, K., Albadi, M.H., Hosseinzadeh, N., 2014. Load frequency control of a multi-area power system: An adaptive fuzzy logic approach. *IEEE Trans. Power Syst.* 29 (4), 1822–1830.
- Yuen, C., Oudalov, A., Timbus, A., 2011. The provision of frequency control reserves from multiple microgrids. *IEEE Trans. Ind. Electron.* 58 (1).
- Zamani, A., Barakati, S.M., Darmian, S.Y., 2016a. Design of a fractional order controller using GBMO algorithm for load frequency control with governor saturation consideration. *ISA Trans.* 64, 56–66.
- Zamani, A., Barakati, S.M., Darmian, S.Y., 2016b. Design of a fractional order PID controller using GBMO algorithm for load frequency control with governor saturation consideration. *ISA Trans.* 64, 59–66.
- Zamani, M., Ghartemani, M.K., Sadati, N., Parniani, M., 2009. Design of a fractional order PID controller for an AVR using particle optimisation. *Control Eng. Pract.* 17, 1380–1387.
- Zhang, W., Fang, K., 2017. Controlling active power of wind farms to participate in load frequency control of power systems. *IET Gener. Transm. Distrib.* 11 (9), 3194–2203.
- Zhang, C.K., Jiang, L., Wu, Q.H., He, Y., Wu, M., 2013. Further results on delays dependent stability of multi-area load frequency control. *IEEE Trans. Power Syst.* 28 (4), 4465–4474.
- Zhang, Y., Liu, X., Qu, B., 2017. Distributed model predictive load frequency control of multi-area power system with DFIGs. *IEEE/CAA J. Autom. Sin.* 4 (1), 125–135.
- Zhang, Y., Liu, X., Yan, Y., 2015. Model predictive control for load frequency control with wind turbines. *J. Control Sci. Eng.* 8, 1–17.
- Zhao, J., Dorfler, F., 2015. Distributed control and optimisation in DC microgrids. *Automatica* 61, 18–26.
- Zhao, Z.Y., Tomizuka, M., Isaka, S., 1993. Fuzzy Gain scheduling of PID controllers. *IEEE Trans. Syst. Man Cybern.* 23 (5), 1392–1398.
- Zhao, H., Wu, Q., Guo, Q., Sun, H., Xue, Y., 2016. Optimal active power control of a wind farm equipped with energy storage system based on distributed model predictive control. *IET Gener. Transm. Distrib.* 10 (3), 669–677.
- Zheng, Y., Jemkins, B.M., Kornbluth, K., Traeholt, C., 2018. Optimisation under uncertainty of a biomass integrated renewable energy microgrid with energy storage. *Renew. Energy* 123, 204–217.
- Zheng, Y., Xu, J., Zhang, Y., Qian, Z., 2017. A distributed model predictive control based load frequency control scheme for interconnected power system using discrete-time laguerre functions. *ISA Trans.* 68, 127–140.
- Zheng, Y., Zhou, J., Zhu, W., Zhang, C., Li, C., Fu, W., 2016. Design of a multi-mode intelligent model predictive control strategy for hydroelectric generating unit. *Neurocomputing* 207, 287–299.
- Zhu, Q., Jiang, L., Yao, W., Zhang, C.K., Luo, C., 2017. Robust load frequency control with dynamic demand response for deregulated power systems considering communication delays. *Electr. Power Compon. Syst.* 45 (1), 75–87.
- Zribi, M., Rashed, M.A., Alrifai, M., 2005. Adaptive decentralised load frequency control of multi-area power systems. *Int. J. Electr. Power Energy Syst.* 27, 575–583.