

Ranger, Bryan J.; Mantzavinou, Aikaterini

Article

Design thinking in development engineering education: A case study on creating prosthetic and assistive technologies for the developing world

Development Engineering

Provided in Cooperation with:

Elsevier

Suggested Citation: Ranger, Bryan J.; Mantzavinou, Aikaterini (2018) : Design thinking in development engineering education: A case study on creating prosthetic and assistive technologies for the developing world, Development Engineering, ISSN 2352-7285, Elsevier, Amsterdam, Vol. 3, pp. 166-174,
<https://doi.org/10.1016/j.deveng.2018.06.001>

This Version is available at:

<https://hdl.handle.net/10419/242290>

Standard-Nutzungsbedingungen:

Die Dokumente auf EconStor dürfen zu eigenen wissenschaftlichen Zwecken und zum Privatgebrauch gespeichert und kopiert werden.

Sie dürfen die Dokumente nicht für öffentliche oder kommerzielle Zwecke vervielfältigen, öffentlich ausstellen, öffentlich zugänglich machen, vertreiben oder anderweitig nutzen.

Sofern die Verfasser die Dokumente unter Open-Content-Lizenzen (insbesondere CC-Lizenzen) zur Verfügung gestellt haben sollten, gelten abweichend von diesen Nutzungsbedingungen die in der dort genannten Lizenz gewährten Nutzungsrechte.

Terms of use:

Documents in EconStor may be saved and copied for your personal and scholarly purposes.

You are not to copy documents for public or commercial purposes, to exhibit the documents publicly, to make them publicly available on the internet, or to distribute or otherwise use the documents in public.

If the documents have been made available under an Open Content Licence (especially Creative Commons Licences), you may exercise further usage rights as specified in the indicated licence.



<https://creativecommons.org/licenses/by-nc-nd/4.0/>



Design thinking in development engineering education: A case study on creating prosthetic and assistive technologies for the developing world

Bryan J. Ranger*, Aikaterini Mantzavinou

Massachusetts Institute of Technology, 77 Massachusetts Avenue, Cambridge, MA, 02139, USA

ARTICLE INFO

Keywords:

Design thinking
Engineering education
International development
Project-based learning

ABSTRACT

A human-centered design thinking approach has been applied to a course at the MIT D-Lab on creating low-cost prosthetic and assistive devices for the developing world. Teams of students with diverse backgrounds are paired with international stakeholders and industry partners to tackle real-world prosthetic technology needs, learn the design process through interactive lectures and workshops in the classroom, and are given the opportunity to conduct testing of the prototypes generated during the semester at field sites around the globe. The revamped course offers a fully immersive design experience that extends beyond the classroom and the semester by stimulating further research, inspiring and motivating student professional development, raising additional grant money and generating peer-reviewed publications and intellectual property. A multifaceted and nontraditional engagement with industry partners, as developed in our course, provides a novel and promising model for development engineering courses to afford unique opportunities to their students. As a result of our new course initiatives mean student enrollment has tripled and total project continuation beyond the end of the class has exceeded 60%. In this paper, we outline our framework for incorporating human-centered design thinking into development engineering education, provide outcomes, and present case studies of select projects that have successfully emerged from our course. Our novel pedagogical approaches and collaborative efforts showcase a promising way to engage students in impact-focused project-based learning with long-term benefits for their projects as well as their career development opportunities.

1. Introduction

In recent years, engineering programs at universities have gradually shifted pedagogy away from the traditional deductive approach towards encouraging students to develop deeper levels of contextual understanding; this is meant to not only challenge students to critically reflect on the broader impacts of their work, but to develop real-world skills such as persistence, flexibility, and adaptiveness that are necessary for their professional success (Sheppard et al., 2008; de los Rios-Carmenado et al., 2015; Alves et al., 2018). A means to promote this in the classroom has been the incorporation of project-based learning (PBL) (Blumenfeld et al., 1991; Wiek et al., 2014; Han et al., 2015) and human-centered design (HCD) thinking (Brown and Wyatt, 2015), which provide a toolkit for needs assessment, creative ideation, and rapid iterative improvement for solving problems. This notion is further emphasized in educational studies such as one presented by Dym et al. in their 2005 *JEE* paper (Dym et al., 2005), which recommend that engineering programs make enhanced design pedagogy a high priority in future resource allocation decisions, as well as in a 2014 paper in

Science, Technology, & Human Values that calls for more socially engaged engineering (Cech, 2014).

A notable application of PBL and HCD thinking to the classroom has been in the cross-disciplinary field of development engineering, which aims to design and implement appropriate technologies to spur economic and social development in areas with limited resources (Nieusma, 2004; Margolin, 2007; Oosterlaken, 2009). HCD thinking as applied to development engineering is unique in its focus on (i) incorporating international development goals, (ii) scaling for impact, and (iii) integrating novel yet lean technologies (Levine et al., 2016). A pioneer in this field is the MIT D-Lab - founded in 2002, it was established to advance collaborative approaches and practical solutions to global poverty challenges. The D-Lab is home to interdisciplinary courses, field-engaged research, technology development and community initiatives, all of which emphasize experiential learning, real-world projects, community-led development, and scalability (MIT, 2017).

A course was launched almost a decade ago under the auspices of the MIT D-Lab by a group of graduate students who worked on advanced prosthesis research and sought to teach MIT undergraduates the

* Corresponding author.

E-mail addresses: branger@mit.edu (B.J. Ranger), amantzav@mit.edu (A. Mantzavinou).

fundamentals of creating low-cost prostheses for resource-constrained settings. The course, titled *Developing World Prosthetics* (DWP), has since been regularly offered as part of the MIT D-Lab course roster. There are numerous motivations for running a course that specifically focuses on prosthetic and assistive technologies for developing world contexts. The unmet public health need is tremendous: according to the WHO, there were nearly 30 million amputees living in low-income countries in 2010 (WHO, 2011) and studies have estimated that only 5–15% had access to prosthetic devices (Andrysek, 2010). The statistics are expected to have become even worse as income and resource access inequality have grown particularly in developing countries. There is also a significant need for more communication between countries and prosthetics programs in order to effectively serve this population (Cummings, 1996). A profound opportunity therefore exists to innovate radically affordable prosthetic technologies for developing countries and impact the lives of millions of people.

Early iterations of DWP did not have a dedicated structure for teaching the design process, relied on students to define semester projects based on their own background research, offered very limited support for in-class prototyping and no resources for prototype field-testing, and made minimal connections with industry or subject matter experts. Students consequently gained exposure to hands-on prosthetic design for the developing world but their projects rarely continued beyond the end of term and they critiqued the class for lacking organization, resources and support. The course has since evolved to a fully immersive design experience pairing student teams with real-life stakeholders and, most recently under our direction, forming close ties with industry partners and encouraging field-testing as a key part of the course experience. Starting with the 2015 iteration when our team took the helm in its instruction, the course underwent a foundational restructuring to place greater focus on establishing long-term relationships with international partners, partnering with industry and pursuing project scalability and sustainability in low-resource settings. Students now work on prosthetic and assistive devices for upper and lower extremities inspired by technologies used both in the limited- and the high-resource setting, and funds have been raised to support students during field-testing of their prototypes across the globe. The course curriculum today incorporates two primary teaching foci: (i) basics of human biomechanics, types of disabilities and available technologies for physical rehabilitation, and (ii) challenges of entrepreneurship and medical innovation in limited-resource settings and fundamentals of cost-effective technology dissemination with long-term viability.

To emphasize the importance of scalability, sustainability and overall translatability of the projects that the students pursue during the semester, an international field trip to the base of operations of each team's international partner for prototype evaluation was added as a recommended but not mandatory step after the official end of the semester. These trips, generally lasting 1–2 weeks, take place during the winter or summer break when students normally pursue independent activities on or off campus. Our course supports the students who choose to embark on an international field trip by (i) partly covering the cost of the trip, (ii) connecting the students with the MIT International Science and Technology Initiative (MISTI) to assist with funding and planning of the trip and (iii) assisting the students with paperwork related with conducting human subject research for their prototype testing.

DWP was established under the hypothesis that development engineering education can be merged with industry and close partnerships with international organizations. The ultimate goal of the DWP instructional staff to this end is to engage our students in creative HCD thinking that is societally, financially, and technologically sensible for the setting to which it is applied and encourages them to embrace design and making as a way of learning. Our vision is for the students to

develop prototypes of new products and bring them to the cusp of early-stage deployment. We then move on to support the students if they choose to pursue these endeavors further or help them pair with D-Lab or other scale-up courses that will move their projects forward. In our recent paper (Ranger and Mantzavinou, 2017), we discussed our pedagogical approach and collaborative efforts, and provided a general overview of the course. In this paper, we substantially expand on our previous discussion and also specify outcomes; in doing so, we present an effective framework for incorporating HCD thinking and industry partnerships into development engineering education.

2. Course structure

2.1. Course milestones

DWP is a single-semester class meeting twice per week. There are no pre-requisites to participate in the course. Student progress unfolds following several key objectives:

1. Gain awareness of the socioeconomic and technological challenges faced by communities in the developing world
2. Explore the approaches that MIT and other academic institutions can take in order to design products for consumers in developing countries
3. Survey existing prosthetic and assistive technologies for these consumers, and assess their impact
4. Reconstruct how these technologies were conceived, designed and implemented
5. Identify the limitations of these technologies, determine where there is room for innovation, and formulate solutions to these challenges - this constitutes the core aspect of the course
6. Learn the hands-on skills required to implement selected prosthetic and assistive technology projects
7. Recognize the challenges associated with designing for scale and successfully implementing low-cost medical technologies in limited-resource settings
8. Prototype prosthetic technology solutions and experimentally evaluate them in a systematic way, including multiple prototype iterations
9. Submit proposals for project continuation and field-testing; this includes developing timelines, furthering on-ground partnerships, drafting human subject research protocols, and establishing budgets
10. Execute field-testing plans with international partner organizations, collect feedback, and iterate on design

2.2. Project selection and team formation

Prior to the start of the course each semester, the instructors actively seek out international partner organizations who (i) can clearly articulate several clinically relevant prosthetic or assistive technology challenges that they face at their location, (ii) are willing to provide feedback to the students over the course of the semester as needed, and (iii) are open to students visiting their site for prototype testing after the end of the semester and willing to help guide and mentor them on-site. The partner identification strategy carried out by the course instructors is two-pronged: (1) partners with whom student teams worked successfully in previous semesters are invited to join again with new challenges at each course iteration; and (2) new partners are identified through professional contacts made at conferences related to low-cost prosthetic or assistive technologies or, at times, following outreach by a prospective partner organization made aware of the DWP course through professional channels or social media. Written project proposals are solicited from each potential partner and the three criteria for

Table 1
Partner organizations for 2015 and 2017 course iterations.

Organization	Location	Course Year
Refugee Open Ware	Amman, Jordan	2015
CURE International	Addis Ababa, Ethiopia & Kijabe, Kenya	2015
Jaipur Foot Organization	Jaipur, India	2015, 2017
Mobility India	Bangalore, India	2015, 2017
STAND The Haiti Project	Port-de-Paix, Haiti	2017
Rise Legs	Bangalore, India	2017
Transitions Foundation	Antigua, Guatemala	2017

partner selection outlined above are strictly applied to review the proposals and the prospective partner organizations. Each prospective partner can propose multiple projects. The instructors identify a shortlist of projects for in-class presentation and selection by the students, outlined in more detail in the following paragraphs. Effort is made to communicate with the prospective partner over video conference at least once before the start of the semester to establish a relationship and assess their fit for the course, if they are new to the partner roster. A list of international partners from the 2015 and 2017 course iterations are summarized in Table 1.

On the first day of class, instructors move beyond logistics to kick off the semester with a showcase of previous projects by class alumni. In line with our vision that our students produce sustainable and viable innovations, we spotlight teams that have continued their projects after the end of the class. We believe that presenting continued projects right from the onset is critical to success in the class for the following reasons: (i) it illustrates what is achievable in the span of a semester course, (ii) it normalizes the notion of a well-rounded project that thoughtfully considered a long-term viability plan, and (iii) it demonstrates that our class can lead to projects with promise for far-reaching real-world impact, inspiring the incoming students.

The second class is focused on presenting challenges outlined by our partner organizations as a starting point for establishing semester team projects. These challenges can vary significantly between partners and from year to year - some partners provide a very specific technical problem that they face while others present more systemic challenges. In our experience, this approach has been effective since it tailors to the diverse learning styles of the students: some prefer projects with a very clear deliverable in mind, while others are excited by the creative opportunities afforded by starting from an empty slate. Given that our course relies heavily on the students becoming invested in their projects beyond simply meeting course expectations, we also open the floor during this second class period to students who would like to pitch a project idea of their own.

Following presentation of the challenges, multidisciplinary student teams of 4-5 students are formed in part naturally, by letting students mingle freely during class time to discuss their projects of interest, and in part more systematically through an online questionnaire. In the questionnaire that we developed, students rank their project preferences, provide reasoning for their interest in their preferred projects, and also present information on their own background. The course staff subsequently carries out the systematic part of team formation looking primarily at student project preferences, but also at seniority, experiences, and background skills, in an effort to assemble diverse, dynamic and well-balanced teams. Independent team formation on the students' part is allowed permitted that they have a balance of interests and skills.

Each student team is assigned a teaching assistant (TA) who acts as a mentor through the entirety of the course. The TA plays a crucial role in the success of the project. Each TA meets on a weekly basis with their team to guide the students through all aspects of the design process.

This includes guiding the students through design thinking decisions, as well as providing hands-on support during the prototyping phase. The TAs have extensive experience in prosthetic design and international field work and are commonly graduate students or in rare cases exceptional senior undergraduate students who are alumni of the course.

2.3. Course curriculum

The core aspect of the course is an extensive and fully immersive design project explained in detail in Section 3. Beyond the design project, we recruit numerous guest lecturers to give presentations on topics related to the course. We frequently include a local prosthetist who gives an interactive lecture on various aspects of their job, entrepreneurs who have successfully started ventures related to global development, representatives from the private sector and speakers from across the academic community who discuss topics such as designing for scale, business models for medical innovation in the developing world, accessibility and distribution of medical devices, and advanced prosthetics research. We also have more interactive classes, such as rapid build sessions to make preliminary concept models out of miscellaneous supplies in the D-Lab machine shop (e.g., cardboard, wire, wood, etc.).

2.4. Assignments and grading

Approximately ten homework assignments are given throughout the semester as preparation for an upcoming lecture, making up 20% of the final grade. Comprising 50% of the final grade are three in-class team presentations. Each presentation is approximately 15 minutes long, with an additional 5 minutes for questions and feedback. Detailed rubrics for each presentation are provided to the students ahead of time as preparation so that expectations are clear. Instructors, TAs, and outside mentors contribute to grading. The remaining 20% of the grade comprises a final report from each team written in the form of an American Society of Mechanical Engineers (ASME) conference paper.

2.5. Industry collaboration

A unique aspect of DWP is our close collaboration with industry partners. As an example, for the past three iterations of the course we have partnered with Autodesk. The partnership was formed under the premise of the company's educational outreach efforts with a two-sided goal. From the DWP perspective, the course instructors get access to the Autodesk computer-aided design (CAD) and prototyping resources for our students as well as grant money to help cover field trip expenses, while the students are able to also cultivate professional relationships that may extend beyond the semester in the form of internships or full-time opportunities. From the Autodesk perspective, the industry partner gets to gather data on utilization of their CAD software for educational purposes and to actively engage MIT undergraduates with their company. We consider this kind of two-sided partnership with industry that is focused on engineering education key to allow our course to sustainably provide the resources necessary for prototyping, international field-testing and long-term career development opportunities to our students.

We have also engaged leaders in design thinking including IDEO and Continuum Innovation to run workshops for our students that focus on HCD and its potential for social impact (Fig. 1). Representatives from the design firm specifically work with each student team to: (i) gather and cluster relevant observations and background research to identify critical themes, (ii) extract relevant insights from these themes and synthesize them and (iii) help establish milestones for moving the project forward. These workshops have been quite successful: students have indicated that feedback from those working in this industry has



Fig. 1. Students in DWP take part in a design workshop.

helped them make decisions during the course of prototyping and iterating on their designs.

2.6. International field testing opportunities

We are fortunate to have several international programs at MIT that offer students the opportunity to live, work, and study abroad. One program, the MIT International Science and Technology Initiative (MISTI), has been an exceptional partner to help us realize student international travel for field-testing their prototypes in Asia and Africa. MISTI provides financial and logistical support in planning and executing student travel, as well as preparation for the students' international experience (e.g. local language and customs lessons etc.) (MISTI, 2017).

Offering the option of international field-testing travel to our students is both a substantial commitment and a source of major satisfaction for them and us. We work diligently for months ahead of each course offering to carry out outreach to industry partners and MIT liaisons like MISTI in order to secure funding and logistical support for this travel so that students will not have to pay out of pocket. We also work to identify reliable on-the-ground partners that can host this kind of field-testing activity for our teams. We believe that field-testing with on-the-ground partners goes beyond an international immersion and the scientific merit of prototype evaluation to add an extra layer of accountability and real-world complexity to the student experience. The student response to our staff providing resources for international field-testing has been extremely enthusiastic, hiking up student registration numbers for our course (refer to Section 4 for enrollment numbers over the years) and making it one of the most popular MIT D-Lab courses to date. Travel for field-testing, albeit requiring significant extra work on behalf of the teaching staff and a strong early commitment on behalf of the students, has been an extraordinarily enriching experience for our students and has inspired many to continue their projects beyond the course.

3. Design process

To drive progress on the student projects, we instruct them to follow a clear design process from the beginning and require them to produce deliverables throughout the semester. Much of this process is based on our own learnings from a graduate medical device design course offered

by the MIT Mechanical Engineering Department (Hanumara et al., 2013). We have modified the process described by Hanumara et al. to take into account the undergraduate status of our students - some are exposed to design for the first time in our class - and the tailored focus of our course to challenges related to areas of constrained resources. The design process is taught to students through class lectures, project-specific mentorship from the team's assigned TA, and assigned readings. Fig. 2 provides an overview of the design process that we teach, including the amount of time spent on each section, and each main topic is further explored in the following subsections.

3.1. Background research

Once student teams have been assigned a challenge and partner organization to work with, and before considering a solution to that challenge, they are tasked to complete extensive background research. This involves perusing the literature for research articles to better understand the context of the space in which they are trying innovate, performing a prior art search, and exploring currently available solutions. We also encourage students to interview prosthetists, clinicians, and amputees to more holistically understand their clinical problem.

3.2. Mission statement

We require that each team develop a clear and concise statement that details what they plan to accomplish during the semester. This forces teams to immediately focus on what is most important, and provides a way for students to map their progress and rationalize their next steps when they present to class.

3.3. Functional requirements and design parameters

Before starting to devise a solution, it is important to define its functional requirements; that is, create a list of independent functions that the intended solution must accomplish. Functional requirements are developed in collaboration with the partner organization and should be quantitative or binary so that they may be tested as part of prototype evaluation. For example, functional requirements could consist of metrics like height and weight with clear cutoffs to be met, or a binary requirement such as 'readily serviceable and maintainable in a resource-constrained environment.' Once the team has a clear set of

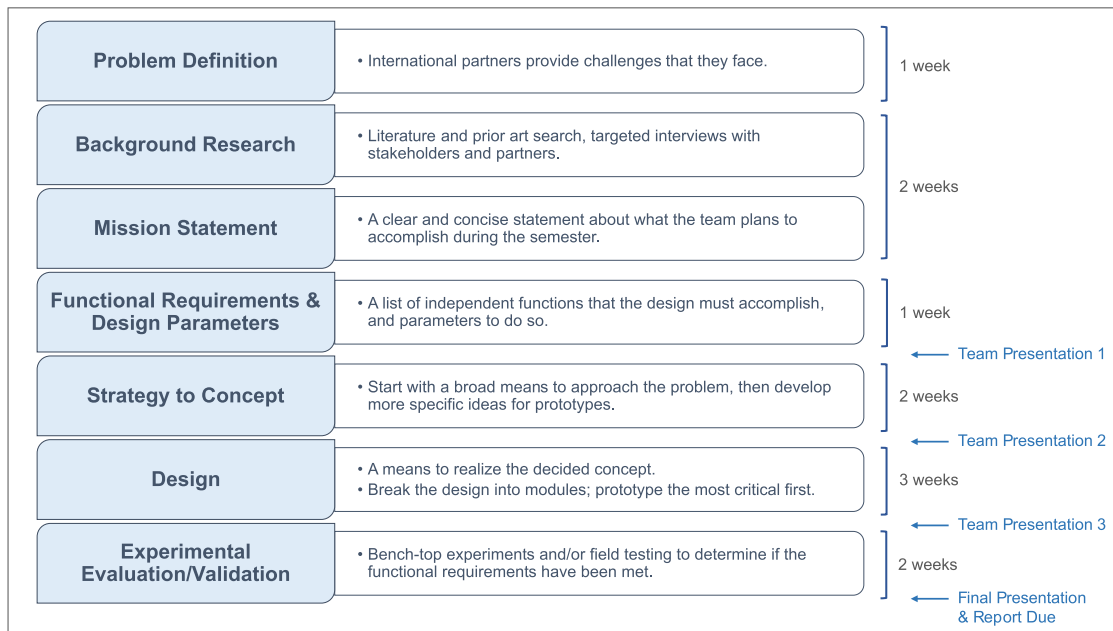

Fig. 2. Design process taught as part of the DWP curriculum. International partners help define challenges for student teams to work on. The teams then perform a background literature search, develop a mission statement to describe their semester goals, define functional requirements, and move from broad strategy to final design. The process concludes with a detailed experimental evaluation of their prototype. The amount of time spent on each section, and times of team presentations are also indicated.

functional requirements, they move on to develop design parameters for each. Design parameters represent an independent means to achieve each functional requirement.

3.4. Concept

With functional requirements and design parameters defined, we encourage students to think broadly as they begin to devise a solution; we refer to the products of this thinking as ‘concepts’ and consider them to be the step before prototype creation. To illustrate the difference, a team who may be developing a prosthetic socket may generate concept ideas that include a pin-lock or vacuum mechanism for attachment to the residual limb. The details of how either system will be achieved are not part of this concept, but will be explored as the team moves from the conceptual to the prototyping phase. The student teams are asked to present their top three concept ideas to the class a few weeks into the term, discuss pros and cons of each concept and solicit feedback from their classmates and the instructors. At this stage, we encourage students to create Pugh Charts (i.e., criteria weight matrices) to help weigh the pros and cons of their ideas so that they can effectively iterate in the next stage.

3.5. Design and prototyping

Once the student team has decided on a concept after gathering feedback, they enter the design generation and prototyping phase - a specific realization of their chosen concept. Design generation can take several forms depending on the nature of the project. We encourage students to approach their design as an assembly of modules. Using this breakdown they can decide which module is the most critical. This “most critical module” (MCM) will be the first to be designed and prototyped and undergo some basic bench-top testing. Having finalized the MCM, the team can create the remaining components of the design around it with the overarching goal of meeting their functional requirements. The teams are again expected to formally present their top

3 design ideas to the class and solicit feedback from their fellow students and instructors prior to the selection of the final design and start of prototyping.

3.6. Experimental assessment/validation

The final yet arguably most important stage of the design process is experimental validation of the prototype. The predominant question during evaluation is to determine whether all functional requirements have been fully or partially met. This is completed by performing basic experiments and/or field testing to evaluate each functional requirement. The testing phase occurs at the end of the semester and concludes with a formal presentation to the class where each team discusses their final design, conclusions and future directions. Outcomes of student projects are assigned a letter grade based on evaluating their design, ease of implementation, knowledge transfer, accessibility, cost, prototype reliability and scalability.

4. Course demographics and evaluation

4.1. Enrollment

A total of 97 students have enrolled in DWP since its first iteration in 2008. Enrollment has approximately tripled after the course was revamped by our instructor team: mean enrollment has jumped from 8 students in the years 2009-2014 to 25 students in the years 2015-2017. Approximately 67% of the total student enrollment in DWP over the years - well over the majority - identified as female. Most students are mechanical engineers (65%) with bioengineers (12%) and other engineering (7%) and science majors (12%) rounding out the majority. Other areas of study such as business and social science are represented to a much smaller extent.

In addition, we have recorded a notable increase in underclassmen (freshmen and sophomores) in more recent iterations. Welcoming a large proportion of underclassmen may require more involvement by

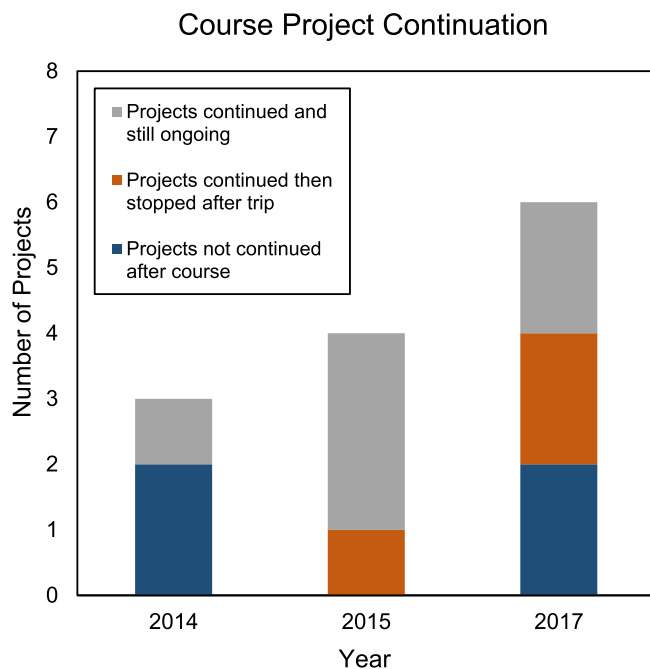

Fig. 3. Number of projects that continued after the course completed for the years 2014–2017.

the teaching staff since the students often do not have much experience prior to the course (e.g. design software knowledge, machine shop experience, team work exposure, etc.). We note, however, several potential benefits: (i) the course acts as a suitable introduction to design model for undergraduates who have had little exposure to engineering; (ii) students will be enrolled at the university for multiple semesters after completion of our course, therefore increasing the likelihood that they will pursue their project beyond the auspices of the semester; and (iii) students are inspired early in their engineering career to use their technical skills to drive social change.

4.2. Teaching evaluations

MIT solicits students to complete anonymous course evaluations at the conclusion of every semester with answers made available to the instructional staff as a form of feedback. Overall class scores have been exceptionally high over the years and feedback has been overwhelmingly positive - one student was quoted saying, "if you want to do big things, meet interesting people, take this class." Critical feedback included the suggestion to allow for more hands-on instructional time for prototyping as well as offer a recitation section outside of lectures and team meeting times with their assigned TA. The instructional staff makes an active effort to read all evaluations and works to incorporate suggested changes in future course iterations.

5. Outcomes

One of the metrics that we have defined to track course success is the number of projects that have continued after the course concludes. For the purposes of this paper, we have divided this classification into three categories: (1) projects continued beyond the course and still ongoing at the time this article was prepared, (2) projects continued after the course but concluded after a trip to the field, and (3) projects not continued. For this analysis, only data from the last three course iterations were available. As shown in Fig. 3, of three projects in 2014 one project continued and is still ongoing, of four projects in 2015 all

four projects continued after the class with three ongoing to this day, and of six projects in 2017 four continued with two ongoing - in total this represents 8 of the 13 projects (62%) initially continued beyond the end of the course and 6 of the 13 projects (46%) still ongoing. This rate of project continuation beyond the end of the semester (and of student evaluation) has been made possible by our continued push to encourage student travel for prototype field-testing as well as our extensive support, connections and mentorship offered to student teams to help them continue their projects past the course auspices. The continuation rate also shows that students are dedicated to the course's overall mission outside of what is required of them academically; we attribute this dedication to the prototype strengths and weaknesses revealed from real end-users during field-testing, which motivate students to continue working on refining their prototype instead of abandoning it once the course was over. Beyond those projects directly continued by respective student teams, several were either left (i) with the international partner for further continuation or (ii) with the course staff in a state permitting their continuation by another team in a future course iteration.

6. Case studies

In this section we describe three projects that were initiated as part of the 2015 course iteration of DWP and have substantially developed beyond the course.

6.1. Transfemoral rotator

Through a partnership with Bhagwan Mahaveer Viklang Sahayayta Samiti (BMVSS) this student team decided to focus their project on the needs of transfemoral amputees in India. At BMVSS transfemoral amputees are routinely provided the Stanford-Jaipur knee, which has been fitted to over 4200 patients with considerable success (Hamner et al., 2013). However, there are certain cultural limitations associated with this product; namely, that patients are unable to comfortably sit cross-legged, which is a position commonly assumed in Indian culture during, praying, eating, and socializing. The student team worked to design an affordable transfemoral rotator that allows for the prosthetic leg to easily rotate and lock in two separate positions for sitting and standing.

In collaboration with MISTI-India the team traveled to Jaipur, India for field testing immediately following the conclusion of our course.

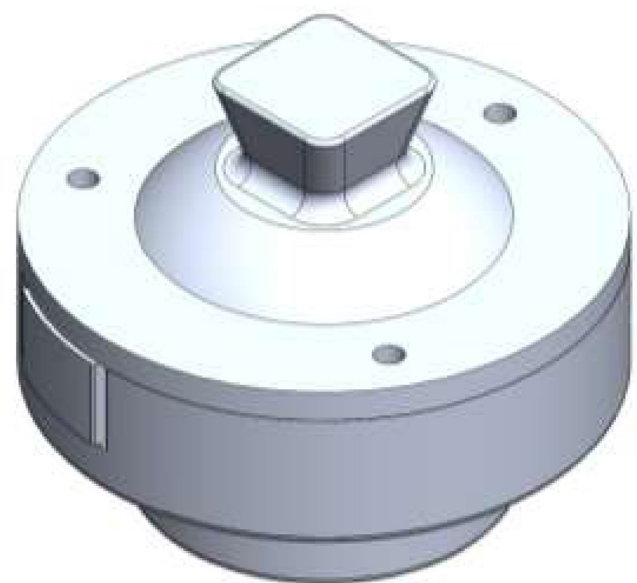

Fig. 4. CAD rendering of the transfemoral rotator.



Fig. 5. Two students testing their socket prototype in a CURE International Hospital located in Addis Ababa, Ethiopia. (Sweeney et al., 2016).

They tested their prototype on patients on-site at BMVSS and received constructive feedback from clinicians. The team continued to iterate on their prototype upon their return, which shown in Fig. 4. They filed a patent and published a manuscript in the American Society of Mechanical Engineers (ASME) Conference (Cavuto et al., 2016). In January 2016 and April 2017 the team took iterated versions of the device to Jaipur Foot and Mobility India and solicited further feedback from users. On their most recent trip to India in August 2017 they worked to develop manufacturing relationships in Bangalore. As such, the team has spun out into a legal entity (Need-a-Knee, LLC) allowing them to license their technology from MIT.

The Need-a-Knee team has garnered numerous accolades in their pursuits: ASME ISHOW National Finalist, MIT IDEAS Global Challenge 2017 Winners (\$10,000), MIT Sloan Healthcare Innovations Prize Runner-Up (\$4000), MIT 100 K Semifinalist (\$1000), DeFlorez Engineering Design Award (\$1250), Clinton Global Initiative University Invitee, Legatum Seed Grant (\$2000), and MIT Sandbox Fund Grant (\$5000). The team was also invited to provide a guest lecture at IIT Delhi on 'Inclusive Innovation.'

6.2. SmartSocket

The goal of this project is to create a more comfortable interface between the patient and their prosthesis since daily fluid shifts in the transtibial residual limb can frequently cause user discomfort (Sanders et al., 2012). Toward this goal, the team developed a low-cost multi-material prosthetic liner. Upon completion of the course, the team ran field trials at CURE International Hospitals in Kijabe, Kenya and Addis Ababa, Ethiopia (Fig. 5) (Sweeney et al., 2016). For these trials, experimental subjects were asked to quantitatively rate their comfort and also provide feedback on aesthetics. As described by the team, one of the main lessons learned was that of the importance co-creation - working alongside prosthetists in Kenya and Ethiopia was vital in order to understand the cultural context required for continuing to innovate in their chosen setting. This team has continued to work and iterate on their prototype since traveling; they received funding from the MIT Undergraduate Giving Campaign (UGC) and Tau Beta Pi and were recently a MIT IDEAS Global Challenge Winner.

6.3. Adjustable socket

This project aimed to create a cost-effective transfemoral prosthetic socket that could adjust to distribute load across an amputee's residual limb despite day-to-day limb shape, size, and volume fluctuations. In collaboration with MISTI-India several members of this student team traveled to Bangalore, India to work with the organization Mobility India. They were able to iterate their device on-site and also received critical feedback from patients regarding their design. This group made use of several Autodesk software platforms in order to capture shape of a residual limb and created a virtual socket design. One of the student team members continued this project as part of an internship with Autodesk after field-testing. As a result, this project has advanced significantly beyond what was originated in the course (Fig. 6). The student who continued the project as an intern recently received a \$10,000 OZY Genius Award allowing her to continue her project in Rwanda. Aspects of the project also turned into a design course now available on the Autodesk Design Academy (Speers, 2016).

7. Conclusion

DWP was created under the premise that development engineering education can, and should, be merged with industry and close partnerships with international organizations. To this end, this paper describes a course framework for teaching HCD through PBL while engaging with industrial and international partners to create prosthetic devices for resource-constrained environments and could reasonably be translated to other topics in development engineering education. Students in our course are expected to design and prototype a device that is societally, financially, and technologically sensible for the setting to which it is applied. Following our approach, 8 of 13 student projects (62%) have continued beyond the auspices of the course making significant progress toward translation and receiving numerous awards and distinctions. Further development of the course curriculum is ongoing as we aim to incorporate student feedback and continue motivating engineering students to design for social impact.



Fig. 6. Rendering of adjustable socket (Speers, 2016).

Declarations of interest

None.

Acknowledgements

The authors would like to thank the faculty and staff of the MIT D-Lab for their support and guidance; in particular, we thank Libby Hsu, Amy Smith, Nancy Adams, Melissa Mangino, Richard Brewer and Bob Nanes. This course would not have been possible without the dedication of past and present instructors and teaching assistants; this includes Matt McCambridge, David M. Sengeh, David Hill, Katherine Olesnavage, Murthy Arelekatti, Ken Endo, Todd Farrell, Matthew Furtney, Shriya Srinivasan, Matthew Chun and Matthew Cavuto. We acknowledge all the students who have taken this course, whose hard work and engagement have helped make it successful - in particular, we thank the students whose projects are featured in this manuscript: Karl Baronov, Matthew Chun, Matthew Cavuto, Keriann Durgin, Nora Kelsall, Michelle Zhou, Katelyn Sweeney, Erica Green, Trang Luu, Nick Schwarz, Krithika Swaminathan and Claudine Humure. We thank our invited experts and international partners who provide invaluable feedback for our students and help shape the direction of projects in the course; this includes but is not limited to Mobility India, the Jaipur Foot Organization, Refugee Open Ware, RiseLegs, STAND-Haiti, Transitions Foundation Guatemala, Continuum Innovation, IDEO, Rogerson Prosthetics and Orthotics and A Step Ahead Prosthetics. We thank MISTI-India (Mala Ghosh and Molly Gallagher), MISTI-Arab World (David Dolev), MIT Undergraduate Giving Campaign and MIT Tau Beta Pi who have graciously provided funding to offset student travel costs for field testing. Finally, the authors would like to thank Autodesk, particularly our direct collaborators Sunand Bhattacharya and Erica Nwankwo, for their extraordinarily generous and continued support of the course. This course is funded by the MIT D-Lab and Autodesk Education.

References

- Alves, A.C., et al., 2018. Project-based Learning and its Effects on Freshmen Social Skills in an Engineering Program. *Human Capital and Competences in Project Management*.
- Andrysek, J., 2010. Lower-limb prosthetic technologies in the developing world: a review of literature from 1994–2010. *Prosthet. Orthot. Int.* 34 (4), 378–398.
- Blumenfeld, P., et al., 1991. Motivating project-based learning: sustaining the doing, supporting the learning. *Educ. Psychol.* 26 (3 & 4), 369–398.
- Brown, T., Wyatt, J., 2015. Design thinking for social innovation. *Ann. Rev. Policy Des.* 3 (1), 1–10.
- Cavuto, M.L., et al., 2016. Design of mechanism and preliminary field validation of low-cost transfemoral rotator for use in the developing world. In: *ASME 2016 International Design Engineering Technical Conferences and Computers and Information in Engineering Conference*.
- Cech, E.A., 2014. Culture of disengagement in engineering education? *Sci. Technol. Hum. Val.* 39 (1), 42–72.
- Cummings, D., 1996. Prosthetics in the developing world: a review of the literature. *Prosthet. Orthot. Int.* 20, 51–60.
- de los Rios-Carmenado, I., et al., 2015. Promoting professional project management skills in engineering higher education: project-based learning (PBL) strategy. *Int. J. Eng. Educ.* 31 (1), 184–198.
- Dym, C.L., et al., 2005. Engineering design thinking. *J. Eng. Edu.* 103–120 (January).
- Hamner, S.R., Narayan, V.G., Donaldson, K.M., 2013. Designing for scale: development of the remotion knee for global emerging markets. *Ann. Biomed. Eng.* 41 (9), 1851–1859.
- Han, S., Capraro, R., Capraro, M.M., 2015. How science, technology, engineering, and mathematics (stem) project-based learning (Pbl) affects high, middle, and low achievers differently: the impact of student factors on achievement. *Int. J. Sci. Math. Educ.* 13 (5), 1089–1113.
- Hanumara, N.C., et al., 2013. Classroom to clinic: merging education and research to efficiently prototype medical devices. *IEEE J. Transl. Eng. Health Med.* 1, 1–7.
- Levine, D.I., Agolino, A.M., Lesniewski, M.A., 2016. Design thinking in development engineering. *Int. J. Eng. Educ.* 32 (3), 1396–1406.
- Margolin, V., 2007. Design for development: towards a history. *Des. Stud.* 28 (2), 111–115.
- MISTI, 2017. MIT International Science and Technology Initiatives (MISTI). Available at: mist.mit.edu (Accessed: 27 August 2017).
- MIT, 2017. MIT D-lab. Available at: d-lab.mit.edu (Accessed: 27 August 2017).
- Nieusma, D., 2004. Alternative design scholarship: working toward appropriate design. *Des. Issues* 20 (3), 13–24.
- Oosterlaken, I., 2009. Design for development: a capability approach. *Des. Issues* 25 (4), 91–102.
- Ranger, B., Mantzavinou, A., 2017. A course in prosthetics for the developing world: merging education, research, and industry to teach biomedical design for social

- impact. In: IEEE Engineering in Medicine and Biology Conference.
- Sanders, J.E., et al., 2012. Preliminary investigation of residual-limb fluid volume changes within one day. *J. Rehabil. Res. Dev.* 49 (10), 1467–1478.
- Sheppard, S.D., et al., 2008. Educating engineers: designing for the future of the field. *Edu. Eng.* 81 (October), 272.
- Speers, F., 2016. Designing an Adjustable Prosthetic Socket Using ReMake and Fusion 360. Autodesk Design Academy Available at: <https://academy.autodesk.com/inspiration/blog/designing-adjustable-prosthetic-socket-using-remake-and-fusion-360> (Accessed: 27 August 2017).
- Sweeney, K., Schwartz, N., Luu, T., 2016. D-lab: Prosthetics Students Test Transtibial Prosthetic Liner in Kenya & Ethiopia. MIT D-Lab Blog Available at: <https://d-lab.mit.edu/news/d-lab-prosthetics-students-test-transtibial-prosthetic-liner-kenya-ethiopia> (Accessed: 27 August 2017).
- WHO, 2011. *World Report on Disability*.
- Wiek, A., et al., 2014. Integrating problem- and project-based learning into sustainability programs. *Int. J. Sustain. High Educ.* 15 (4), 431–449.