

Kliestik, Tomas (Ed.); Valaskova, Katarina (Ed.); Kovacova, Maria (Ed.)

Book — Published Version

Quantitative methods in economics and finance

Provided in Cooperation with:

MDPI – Multidisciplinary Digital Publishing Institute, Basel

Suggested Citation: Kliestik, Tomas (Ed.); Valaskova, Katarina (Ed.); Kovacova, Maria (Ed.) (2021) : Quantitative methods in economics and finance, ISBN 978-3-0365-0537-4, MDPI, Basel,
<https://doi.org/10.3390/books978-3-0365-0537-4>

This Version is available at:

<https://hdl.handle.net/10419/237809>

Standard-Nutzungsbedingungen:

Die Dokumente auf EconStor dürfen zu eigenen wissenschaftlichen Zwecken und zum Privatgebrauch gespeichert und kopiert werden.

Sie dürfen die Dokumente nicht für öffentliche oder kommerzielle Zwecke vervielfältigen, öffentlich ausstellen, öffentlich zugänglich machen, vertreiben oder anderweitig nutzen.

Sofern die Verfasser die Dokumente unter Open-Content-Lizenzen (insbesondere CC-Lizenzen) zur Verfügung gestellt haben sollten, gelten abweichend von diesen Nutzungsbedingungen die in der dort genannten Lizenz gewährten Nutzungsrechte.

Terms of use:

Documents in EconStor may be saved and copied for your personal and scholarly purposes.

You are not to copy documents for public or commercial purposes, to exhibit the documents publicly, to make them publicly available on the internet, or to distribute or otherwise use the documents in public.

If the documents have been made available under an Open Content Licence (especially Creative Commons Licences), you may exercise further usage rights as specified in the indicated licence.



<https://creativecommons.org/licenses/by-nc-nd/4.0/>



risks

Quantitative Methods in Economics and Finance

Edited by

Tomas Kliestik, Katarina Valaskova and Maria Kovacova

Printed Edition of the Special Issue Published in *Risks*

Quantitative Methods in Economics and Finance

Quantitative Methods in Economics and Finance

Editors

Tomas Kliestik

Katarina Valaskova

Maria Kovacova

MDPI • Basel • Beijing • Wuhan • Barcelona • Belgrade • Manchester • Tokyo • Cluj • Tianjin



Editors

Tomas Kliestik
University of Zilina
Slovakia

Katarina Valaskova
University of Zilina
Slovakia

Maria Kovacova
University of Zilina
Slovakia

Editorial Office

MDPI
St. Alban-Anlage 66
4052 Basel, Switzerland

This is a reprint of articles from the Special Issue published online in the open access journal *Risks* (ISSN 2227-9091) (available at: https://www.mdpi.com/journal/risks/special_issues/Quantitative_Methods_Economics_Finance).

For citation purposes, cite each article independently as indicated on the article page online and as indicated below:

LastName, A.A.; LastName, B.B.; LastName, C.C. Article Title. *Journal Name* **Year**, Volume Number, Page Range.

ISBN 978-3-0365-0536-7 (Hbk)

ISBN 978-3-0365-0537-4 (PDF)

© 2021 by the authors. Articles in this book are Open Access and distributed under the Creative Commons Attribution (CC BY) license, which allows users to download, copy and build upon published articles, as long as the author and publisher are properly credited, which ensures maximum dissemination and a wider impact of our publications.

The book as a whole is distributed by MDPI under the terms and conditions of the Creative Commons license CC BY-NC-ND.

Contents

About the Editors	vii
Preface to “Quantitative Methods in Economics and Finance”	ix
Sergey A. Vasiliev and Eugene R. Serov Omnichannel Banking Economy Reprinted from: <i>Risks</i> 2019 , 7, 115, doi:10.3390/risks7040115	1
Adam Marszk and Ewa Lechman Application of Diffusion Models in the Analysis of Financial Markets: Evidence on Exchange Traded Funds in Europe Reprinted from: <i>Risks</i> 2020 , 8, 18, doi:10.3390/risks8010018	13
Pavol Durana, Katarina Valaskova, Darina Chlebkova, Vladislav Krastev and Irina Atanasova Heads and Tails of Earnings Management: Quantitative Analysis in Emerging Countries Reprinted from: <i>Risks</i> 2020 , 8, 57, doi:10.3390/risks8020057	37
Bernd Engelmann and Ha Pham A Raroc Valuation Scheme for Loans and Its Application in Loan Origination Reprinted from: <i>Risks</i> 2020 , 8, 63, doi:10.3390/risks8020063	59
Long Hai Vo and Duc Hong Vo Modelling Australian Dollar Volatility at Multiple Horizons with High-Frequency Data Reprinted from: <i>Risks</i> 2020 , 8, 89, doi:10.3390/risks8030089	79
Zbigniew Palmowski and Tomasz Serafin A Note on Simulation Pricing of π -Options Reprinted from: <i>Risks</i> 2020 , 8, 90, doi:10.3390/risks8030090	95
Dmitrii Rodionov, Olesya Perepechko and Olga Nadezhina Determining Economic Security of a Business Based on Valuation of Intangible Assets according to the International Valuation Standards (IVS) Reprinted from: <i>Risks</i> 2020 , 8, 110, doi:10.3390/risks8040110	115
Zuzana Rowland, George Lazaroiu and Ivana Podhorská Use of Neural Networks to Accommodate Seasonal Fluctuations When Equalizing Time Series for the CZK/RMB Exchange Rate Reprinted from: <i>Risks</i> 2021 , 9, 1, doi:10.3390/risks9010001	129

About the Editors

Tomas Kliestik (prof., Ph.D.) is a professor and the head of the Department of Economics, Faculty of Operation and Economics of Transport and Communications, University of Zilina. His application, technical, and scientific activities are focused mainly on the issue of the application of quantitative mathematical-statistical methods in financial management and decision-making process of companies, data envelopment analysis, neural networks, genetic algorithms, fuzzy logic, multivariate statistical methods, risk quantification and analysis, etc. His findings are published in domestic and foreign scientific monographs, academic publications, lecture notes, and the outputs of his research are published in indexed and impact scientific journals (Q1–Q2). More than 1600 citations have been recorded for his publications. His current Hirsch index is 19 in the Web of Science database and 18 in Scopus. He is also a member of the editorial boards of several journals and a member of scientific committees of international scientific conferences, he is also a guarantor and editor of the conference Globalization and its Socio-Economic Consequences.

Katarina Valaskova (Ph.D.) is an associate professor at the Department of Economics, Faculty of Operation and Economics of Transport and Communication, University of Zilina. Her research activities are mostly focused on financial and investment management, risk management, and business economics. She is an author of domestic and foreign monographs, academic publications, lecture notes, and the outputs of her research are published in indexed and impact scientific journals (Q1–Q2). More than 800 citations have been recorded for her publications. Her current Hirsch index is 13 in the Web of Science database and 12 in Scopus. She is also a member of the editorial boards of several journals and a member of scientific committees of international scientific conferences.

Maria Kovacova (Ph.D.) is an assistant professor at the Department of Economics, Faculty of Operation and Economics of Transport and Communication, University of Zilina. Her research activities are mostly focused on financial and investment management and financial markets. She is an author of domestic and foreign monographs, academic publications, lecture notes, and the outputs of her research are published in indexed and impact scientific journals (Q1–Q2). More than 900 citations have been recorded for her publications. Her current Hirsch index is 13 in the Web of Science database and 12 in Scopus. She is also a member of the editorial boards of several journals and a member of scientific committees of international scientific conferences.

Preface to "Quantitative Methods in Economics and Finance"

The beginnings of quantitative methods and mathematical modeling in economics and finance can be traced back to the early stages of the development of classical political economy and are associated with names such as William Petty (1623–1687), Francois Quesnay (1694–1774), Léon Walras (1834–1910), Leonard Euler (1707–1783), Vilfredo Pareto (1848–1923), and many others. After the First World War, there was a massive expansion of quantitative methods, both theoretical and practical, and neither economics nor finance were exceptions. An important milestone in this development was the year 1931, when the Econometric Society was founded and started to issue the *Econometrica* journal on a regular basis. This helped to establish a new scientific branch of econometrics, which considers the mathematical description and statistical verification of economic relations as its main content and, in a broader sense, also the implementation of mathematical methods into economics. The importance of quantitative methods in economics is clearly evident by the number of Nobel Prizes awarded for economics, where mathematical economists form a significant majority of laureates. For the thematic focus of this Special Issue, allow us to mention the most important ones: Leonid Vitalievich Kantorovich, James Tobin, Franco Modigliani, Harry M. Markowitz, Merton Miller, William F. Sharpe, John Forbes Nash, John C. Harsanyi, Robert Merton, Myron Scholes, Robert F. Engle, Clive W. J. Granger, Robert J. Aumann, Leonid Hurwicz, and Eugene Fama.

Tomas Kliestik, Katarina Valaskova, Maria Kovacova

Editors

Article

Omnichannel Banking Economy

Sergey A. Vasiliev and Eugene R. Serov *

International Banking Institute, Nevsky Prospect, 60, 191023 St Petersburg, Russia; ibispb@ibispb.ru

* Correspondence: serov@ibispb.ru

Received: 24 September 2019; Accepted: 4 November 2019; Published: 7 November 2019

Abstract: In modern market conditions, customers who purchase banking products require a high level of service. In particular, they require continuous real-time service with the ability to instantly “switch” between service channels. The article analyzed the economic component of the omnichannel sales management system in banking. The existing barriers to introducing omnichannels to the practice of banking management have been identified. The features of the calculation of individual elements of the cost of sales at various stages of the life cycle of sales (sales funnel) are considered. An economic–mathematical model for managing the cost and profitability of sales by selecting the optimal omnichannel chains was proposed. The omnichannel model of interaction with customers enables banks to simultaneously achieve several key goals of increasing their own business efficiency: increase sales while reducing their cost and improving the quality of customer service. The model can be used not only in banking, but also in other forms of retail business where it is possible to collect detailed statistics and build a factor analysis of conversion through a sales funnel.

Keywords: omnichannel (omni-channel) sales; sales funnel; cost of sales; customer relationship management (CRM); big data; robo-advisor

1. Introduction

In modern conditions, customers purchasing banking products require a high level of service. In particular, they require uninterrupted real-time maintenance with the ability to instantly “switch” between service channels. Omnichannel sales are transactions in which several channels take part in the sale of a single product unit. They are the predicted trend of the next few years of e-commerce (Koneva 2019). Several sales channels coordinated with each other give the customer the opportunity to place an order and receive the ordered product in a way that is convenient for them, without losing the feeling of interaction with the bank’s brand. The bank, for its part, sees sales statistics in a single information store and can manage all channels at once (Koneva 2019).

The issue of “smart” omnichannel sales management is fairly new in the world of science. Its theoretical base has only begun to be formed. Studies in the banking sector have mainly focused on the implementation of various banking services (Shaikh and Karjaluo 2015). Most empirical studies have not provided a clear understanding of the customer experience of omnichannel banking services (Tam and Oliveira 2017). Klaus and Nguyen (2013) explored the role of customer experience in online retail banking services and many studies have focused on different aspects of mobile banking (Sahoo and Pillai 2017). Understanding the factors associated with customer experience in interacting with banks via different channels is not only of interest for banks within the framework of a single ecosystem that creates a universal experience of omnibanking services (Komulainen et al. 2018). Understanding customer experience is recognized as one of the most important current research priorities (Marketing Science Institute 2016). In recent years, interest in managing customer service experience has grown significantly in marketing (Dube and Helkkula 2015).

Omnichannel banking focuses on the principles of consistency, optimization, and seamlessness, with the aim to make the customer experience as satisfactory as possible

(Komulainen and Makkonen 2018). The omnichannel approach should be seen as an evolution of the multichannel approach originating in the retail industry (Rosman 2015; Saghiri et al. 2017). According to studies in the retail sector, if the seller moves from a multichannel model to an omnichannel one, then the buyers of such a store will start spending 20% more money (Okorokov 2016). The difference between omnichannel and multichannel sales is the ability to continue the interaction started in one channel in another channel without the need to duplicate information, as well consistency of price of products and services in all channels.

Despite the general consensus as to the high economic efficiency of introducing the omnichannel approach (due to a multiple reduction in costs), there have been no specific economic calculations done, which reinforces the need for a more detailed analysis with the application of an economic model. The economy of remote retail for omnichannel retailers is determined by the total number of customer orders. According to experts, customers who buy goods and services through a multichannel sales model spend four times more on purchases than orders through monochannel retailers (Retail Pragmatist 2019).

According to IBM, multichannel experiences are no longer a competitive edge, but a “ticket to compete” for banks: a strategic prerequisite for the new era of a digital transaction (Centric Digital 2017). Banking is fundamentally a complex, service-oriented architecture (SOA) of many different systems that unite the different areas of an organization that manage discrete parts of customer experience. With omnichannel implementation, banks can use data collected throughout the customer’s life cycle to create a seamless personalized experience that increases value and satisfaction, reducing maintenance costs (Obilisetty 2019).

The objective of this study was to analyze the economic component of omnichannel sales in banks. In the current market conditions for this business, characterized by a high level of competition with a decrease in market profitability, cost optimization is given primary attention. An effective way to optimize cost is not only to transfer operations from the traditional branch network to remote channels (Internet banking, website, call-center, bots, and other “robo-advisers”), but also to implement competent management omnichannel sales chains. That is, the organization of a system that allows you the sale process to be begun in one channel, to continue in another, and to be completed in the third, while maximizing the overall economic result in the form of profit from sales.

Practical cases of implementing the individual elements described in the Internet resources of the largest banks and other companies in the retail sector, as well as companies implementing IT solutions that support the multichannel sales model (Terrasoft 2019; Koneva 2019), are available mainly to market analysts only. Market analysts consider ready-made practical solutions for building sales through various channels (Internet sites of the company or its partners, mobile applications, social networks, blogs, offline channels). Mobile banking has already become the central driver of a completely customer-centered experience in the world of modern banking.

According to experts, “mobile transactions show a 90% increase in cost savings when compared to an in-branch visit” (Centric Digital 2017). A total 65% of customers already use more than one channel of interaction with their bank, and 80% of banks planned to use video for banking services by the end of 2018 (Centric Digital 2017).

In Sberbank, the share of retail sales in digital channels had already reached 20% by 2017 (including 23% for deposits) and, according to the approved development strategy of Sberbank, the share of services provided in the digital retail bank should reach 60% by 2020 (Sberbank 2018). In Tinkoff Bank, 79% of sales are already made in remote channels (call center, Internet bank, bots), with the prospect of this share reaching 90% in the coming years (Tinkoff 2018).

According to studies, the cost of creating an omnichannel service model is one of the eight main areas of IT spending in banks (Terrasoft 2019). Provided that the solution platform is open and scalable, “the introduction of new remote channels should entail low additional costs” (Retail Pragmatist 2019) for interacting with customers and choosing individual offers with significant development of cross-selling of related products and services.

Knowledge of the customer experience allows the bank to differentiate its products and services to create superior customer value (Jaakkola et al. 2015). Understanding the banking experience is especially important for the banking business in order to increase customer reach, retention, operational efficiency, and market share (Skan et al. 2015).

Based on the above assumptions, this work proposes a methodology for managing the cost and profitability of omnichannel sales by identifying the key factors affecting efficiency, combined in an economic–mathematical model (Materials and Methods). In Section 3 (Results), the model was tested on a conditional example of one of the large Russian banks, and suggestions have been made in key areas for increasing the efficiency of practical applications of the model. Section 4 (Discussion) describes the limitations for implementing the model into banking management practice, as well as methodological assumptions in its construction. Section 5 (Conclusions) summarizes the key findings of the study and suggests directions for its possible development.

2. Materials and Methods

One of the key ideas of the model was to take into account the total cost of the sales process of one unit of the sold product of all activities leading to the final sale, including losses at all stages of the sales funnel (for transactions that did not reach the final sale), as well as all development-related costs associated with sales software support, marketing, and promotion.

In the management and marketing of a retail business, including banking, one of the key factors affecting the ultimate sales efficiency is the number of customers who are offered goods or services (customer flow).

A related indicator is the customer-to-sales conversion rate, which reflects the percentage of customers who ultimately entered into a sale and purchase transaction.

Sales of the product in the channel ($SPch$) for a selected period of time are equal to the product of the target customer flow entered into the channel (CIF) by a statistically determined percentage of the conversion of this flow into sales ($ChConv$):

$$SPch = CIF * ChConv \quad (1)$$

On the other hand, factors also affecting the sales of the product in the channel are: specific sales productivity per employee (SPr), channel resource (number of employees— QSt), and number of working days in a selected period of time when these employees work (t):

$$SPch = SPr * QSt * t, \quad (2)$$

Combining both equations allows us to set up a model of the relationship of the five above-mentioned factors (Equation (3)):

$$CIF * ChConv = SPr * QSt * t \quad (3)$$

At the same time, the cost of sales of the product in the channel ($CSCh$) is equal to the product of the number of actions (operations) necessary to sell one unit of the product in the channel (N), the standard time of each operation (Tn), and the cost of 1 min of employee channel (CCh):

$$CSCh = N * Tn * CCh \quad (4)$$

The cost of 1 min of employee work in the channel is a very convenient and universal indicator for calculating the cost of various processes, and is calculated based on the bank's management accounting data as the ratio of direct administrative and management expenses per channel to the number of channel "sellers", multiplied by their working time fund in minutes per month.

Direct administrative and management expenses include all payments related to labor remuneration (including taxes and deductions to state funds), as well as expenses for maintaining workplaces (rent, utility bills, communication channels, security, depreciation, property tax, etc.) If necessary, it is possible to take into account the indirect costs for labor and maintenance of workplaces for the management personnel administering the “sellers” of the channel.

The universal sales funnel can be divided into three consecutive stages:

- (1) Bring the client a proposal with the aim of generating interest.
- (2) Make a request for a product or service with an interested client.
- (3) Conclude a contract with the client, with subsequent activation of the use of the product.

At each of these stages of the general sales cycle, work can be carried out by an employee, or by an automated “machine algorithm”, in the various channels of interaction with the customer.

In the model and formulas, the stage number of the sales funnel is indicated by the lower index (1, 2, 3—see Equation (5)).

For example, a customer was called by a call center employee, offering to issue a consumer loan. The client promised to think, and after a week he made an application for a loan and insurance via Internet banking. He then applied to the nearest bank office for a cash loan, or, during the next visit to the office to reissue the deposit, the client was offered a payment card. The client, already on his way home, made an order for the card in the online banking mobile application, having issued its delivery to his home by courier.

The total cost of the sales cycle is calculated as the product of the total sales duration of each sales cycle and the cost per minute of the employee of the channel carrying out operations in the cycle (Equation (5)):

$$CSCt = N_1 \times T_1 \times CCh_1 + N_2 \times T_2 \times CCh_2 + N_3 \times T_3 \times CCh_3 \quad (5)$$

It is obvious that the number of actions for one sale depends exclusively on the percentage of conversion of “contacts” into “interests”, “interests” into “bids”, and “bids” into “contracts” within the framework of a universal “sales funnel”. The higher the conversion percentage, the lower the number of operations. In assessing the cost of sales, costs are taken into account not only for those operations that ultimately led to the sale of the product, but also for all outstanding transactions and losses.

Thus, the model for assessing the value and profitability of sales serves as a tool for making complex management decisions for a number of interrelated parameters:

- target customer flow;
- conversion of the target customer flow into sales;
- the number of sellers in the channel;
- specific sales productivity for one seller in the channel for the period (day, month, quarter);
- the cost of 1 min of work channel employee;
- the standard time of one operation in the context of products, channels, stages of the sales cycle;
- the number of actions/operations required for the implementation of one sale of the product in the channel.

Moreover, in the framework of the omnichannel service model, the possibility of separate communication of each channel with customers at different stages of the sales funnel creates the potential to optimize costs by building omnichannel chains that minimize costs, which has been taken into account in the proposed model, which separately estimates the cost of each stage of the sales funnel.

3. Results

By modeling the sales process using selected key factors affecting the overall effectiveness of transactions within the framework of a typical sales funnel, the following ways to increase efficiency

were proposed. According to the model, in order to optimize the cost of sales, it is necessary to (Serov 2018):

- (1) Reduce regulatory time for rendering operations, introducing new technologies, and optimizing processes;
- (2) Reduce the cost of 1 min of work of an employee by selecting channels with the lowest cost of maintaining jobs;
- (3) Reduce the number of transactions required for a sale, automating the processes and selecting channels or sales scenarios with the highest conversion of target client flow into sales.

To test the working capacity in practical conditions, the omnichannel sales cost management model for credit organizations was tested in 2018 at a large Russian bank with a wide branch network and developed alternative sales channels (using conditional figures that were close to reality). In that bank, sales of products were organized through four different channels: branch network, call center, field agent sales to companies (or by courier to a place convenient for the client), and Internet banking or bank website.

At the first stage, for each of these channels, the cost of 1 min of work for one “seller” was estimated (see Table 1).

So, in this example, the highest cost of 1 min of work (0.37 cu) was from one seller in the branch network channel, and the smallest (0.07 cu) was in the Internet channel.

At the second stage of modeling, the cost of sales of one unit of a conditional product in the channel (excluding the costs of developing and maintaining software products, marketing, and promotion) was estimated using Equation (4). A conditional calculation example is given in Table 2.

As can be seen from the model, for the sale of one product in Channel 1, the branch network, it was necessary:

- to offer the service to 50 customers, of which 10% (5 customers) will be interested;
- to offer to issue an application to 5 interested clients, 40% (2 conditional customers) of which will eventually accept;
- only 50% of these applicants (1 client) will reach stage of contract execution, passing the application approval procedure, and wishing to use the product.

The total sales conversion of the full cycle in Channel 1 thus amounted to $2\% = (10\% \times 40\% \times 50\%)$, i.e., of the 50 customers who were offered the product, only 1 was brought to the conclusion of the contract.

According to the time standard for one timed operation, the procedure for the initial offer of Product 1 in Channel 1 lasted 2 min, with filling out an application at 15 min, and checking, concluding a contract, and issuing taking 20 min.

Multiplying the number of operations at the time of each operation and the cost of 1 min of work of the seller, management can obtain the cost of sales of Product 1 in the channel at direct costs: 79 cu, of which the main costs fall in stages I and II of the sales funnel (37 cu and 27 cu), because it was at these stages that the main losses in conversion of the flow into transactions occurred.

The costs of developing and maintaining software, as well as marketing and promotion, were allocated to products and channels in the proportions agreed upon within the bank. First, there was a distribution of the total cost item for individual products, then within each product into the channels, and finally within each channel in proportion to the actual sales for the period in units. An example distribution is shown in Table 3.

Table 1. Calculation of the cost of 1 min of work channel employee.

Name of Sales Channel	Number of Sellers	Payroll with Deductions (Thousand/Month)	Other Direct Costs * (Thousand/Month)	The Cost of 1 Minute of Work for One Channel Seller (from Total Direct Costs, cu)	The Cost of 1 Minute of Work for One Channel Seller (from Total Direct Costs, cu)
	1	2	3	4 = 2/1/FWT **	5 = (2 + 3)/1/FWT **
Channel 1 (Branch)	500	800	1000	0.6	0.37
Channel 2 (Call center)	150	180	60	0.12	0.16
Channel 3 (Direct Sales by Agents)	40	56	20	0.14	0.19
Channel 4 (Internet Banking)	10	24	8	0.06	0.07
Channel 1 (Branch)	500	800	1000	0.16	0.37

* the cost of sellers takes into account the direct costs of rent, utilities, depreciation, and taxes, as well as allocated payroll management staff. It does not include software development/maintenance and marketing costs. ** FWT—working time fund.

Table 2. Calculation of the cost of sales at direct costs.

Name of Sales Channel	The Cost of 1 Min of the Channel Seller, cu	Get the Client's Interest	Accept an Application from the Client by Interest	Checkout Service at the Request of the Client	Get the Client's Interest	Accept an Application from the Client by Interest	Checkout Service at the Request of the Client
			Duration of the operation (minutes)			Number of operations per sale (based on % conversion)	
Branch	0.37	2	15	20	50	5	2.0
Call center	0.16	2	10	1	31	6	2.5
Sales by Agents	0.19	8	5	10	38	29	2.9
Internet Bank	0.07	0.5	1	1	185	3.3	3.3
Name of sales channel	Get the Client's Interest	Accept an Application from the Client by Interest	Checkout Service at the Request of the Client	Full Cycle	Get the Client's Interest	Accept an Application from the Client by Interest	Checkout Service at the Request of the Client
		% conversion by sales funnel (to the previous stage)				Cost of sales at direct costs, cu	
Branch	10%	40%	50%	2%	37	27	1
Call center	20%	40%	40%	3%	10	10	0.4
Sales by Agents	75%	10%	35%	3%	59	28	6
Internet Bank	2%	100%	30%	1%	7	0.2	0.2

Table 3. Distribution to products and channels of software costs and marketing.

Name of Product/Sales Channel	Channel 1 (Branch)	Channel 2 (Call Centre)	Channel 3 (Direct Sales by Agents)	Channel 4 (Internet Banking)	Total
Product/channel share in software development and maintenance costs					
Product 1 (consumer loans):	1%	1%	1%	7%	10%
Product 2 (deposits):	0%	1%	0%	4%	5%
Distribution of monthly average costs for software development and maintenance based on the share of the product/channel (million cu)					0.40
Product 1 (consumer loans):	0.004	0.004	0.004	0.028	0.04
Product 2 (deposits):		0.004	-	0.016	0.02
Share of product/channel in marketing and promotion costs					
Product 1 (consumer loans):	5%	6%	1%	8%	20%
Product 2 (deposits):	10%	0%	0.1%	5%	15%
Distribution of average monthly expenses for marketing and promotion based on the share of the product/channel (million cu)					0.8
Product 1 (consumer loans):	0.04	0.05	0.01	0.06	0.2
Product 2 (deposits):	0.08	-	0.001	0.04	0.1
Average monthly sales of products in channels (pcs)					
Product 1 (consumer loans):	10,000	5,000	500	10,000	25,500
Product 2 (deposits):	20,000	1,000	300	30,000	51,300
The cost of software development/maintenance, marketing and promotion based on 1 pc of sales (cu)					
Product 1 (consumer loans):	4.4	10.4	24.0	9.2	
Product 2 (deposits):	4.0	4.0	2.7	1.8	

In this example, 10% of the average monthly expenses for software development and maintenance (0.04 million out of 0.4 million cu) were allocated to Product 1. In the context of sales channels, the main emphasis in financing was placed on the Internet channel (0.028 million cu or 70% of the total). Similarly, the costs of marketing and promotion can be attributed to products and channels. For example, 20% of the total amount of 0.8 million cu on Product 1 (of which 40% = 0.06 million cu per Internet banking channel).

As a result, based on the units of product sold, in the context of sales channels, the impact of the costs of software development and maintenance, and marketing and promotion ranged from 1.8 cu (deposits in online channels) to 24 cu (consumer loans in direct agent sales).

As can be seen from the calculation, the above specific costs decreased the greater the scale of sales of the product channel. Summing up the previously calculated cost of sales of the product at direct costs with the additional unit costs for software development and maintenance, as well as marketing and promotion, it was possible to calculate the total cost (see Table 4).

Thus, for example, the total cost of sales of one unit of product in the branch network channel is: $78.6 + 4.4 = 83$ cu

Due to the distribution of operations, conversion, and cost between the stages of the sales funnel, the model allowed calculation of the cost not only of sales of the full cycle in a single channel, but also of omnichannel sales chains.

For example, if, instead of selling a product at all stages through one channel (branch network full cycle chain: Br-Br-Br), the first stage, "interest the customer", happens through live communication in the branch network, and then the client navigates to apply for and receive a loan to his account via the digital Internet banking channel (stages 2 and 3 of the sales funnel), then the cost of the received omnichannel chain (Br-IB-IB) for the bank could decrease 2-fold: $40.4 + 0.4 + 0.4 = 41.2$ cu instead of $40.4 + 27.8 + 14.8 = 83.0$ cu.

The cost could be reduced by optimizing the use of the resource of branch network sellers participating only in the first stage of interaction with the client. This, despite a slight decrease in the overall percentage of conversion of the target client flow into transactions (from 2.0% to 1.5% with

a loss of human contact), would lead to an increase in bank profits both per unit of sold products (from 217 up to 259 cu) and per seller per month (from 4.3 to 7.3 thousand cu) (see Table 5).

Table 4. Calculation of cost of sales, taking into account the cost of software and marketing.

Name of Sales Channel	Cost of Sales at Direct Costs (cu)	Get the Client's Interest	Accept an Application from the Client by Interest	Checkout Service at the Request of the Client	Full Cycle	Get the Client's Interest	Accept an Application from the Client by Interest	Checkout Service at the Request of the Client	Full Cycle
Unit costs for software development and maintenance, marketing, and promotion (cu) *					The total cost of sales of 1 unit of product in the channel (cu)				
Branch	78.6	3.9	0.4	0.2	4.4	40.4	27.8	14.8	83.0
Call Center	20.7	8.1	1.6	0.7	10.4	18.3	11.8	1.1	31.1
Direct Sales by Agents	91.9	13.2	9.9	1.0	24.0	71.9	37.4	6.5	116
Internet Bank	7.4	8.9	0.2	0.2	9.2	15.7	0.4	0.4	16.6

* distribution at sales stages is based on the ratio of sales funnel conversions.

Table 5. Omnichannel sales chain scenario parameters.

Name of the Indicator	Br–Br–Br	Br–IB–IB
Target client flow per month, thousand clients	500	417
Conversion of target flow to sales (%)	2.0%	1.2%
Specific sales productivity (pcs. per day for one employee)	1.0	1.3
The number of sellers	500	177
Omnichannel chain sales per month, thousand pieces	10	5
The cost of one sale (cu)	83.0	41.2
Omnichannel chain profit per month (thousand cu)	2170	1294
Profit on 1 unit of sales (cu)	217	259
Profit per one seller per month (thousand cu)	4.3	7.3

Similarly, the model was tested in other omnichannel sales chain optimization scenarios with a call center and direct sales agents. This made it possible to calculate the break-even points for each chain and economically justify investment in the development of these channels with the redistribution of the target client flow along with the resource of sellers to more profitable channels. Based on the practical testing results of the model, the most optimal (with business process parameters that existed at the time of testing) omnichannel sales chain for development was the process wherein the service was offered and the application was filled out (by voice) via the call center, and the conclusion of the contract with money transfer was made via Internet banking (the cost of sales of one loan was \$30, with the conversion of the target customer flow to sales at 3.2%).

4. Discussion

One of the issues debated in building the model was the choice of method by which to allocate the costs of IT, marketing, and promotion per product. Due to the fact that it is practically impossible to accurately determine the proportions of the distribution of these expenses in proportion to the time spent and advertising budgets in the context of individual products and stages of the sales funnel, it was proposed that the above costs be allocated in proportion to the real structure of sales of banking products (either from the previous period or the plan for the next period). As the accuracy of statistics for assessing sales and processes in various dimensions (time, units, financial result) increases, the approaches to allocation and the model can be improved.

Another point of discussion in the process of testing the model was the question of correctly taking into account the specifics of the direct sales channel by agents. This was due to the need to choose an algorithm to distribute costs “on the road” to customers and then, if necessary, again to the bank office, between the stages of the sales funnel. As a result, an agreement was reached that these costs would be entirely allocated to the first stage of the sales funnel (to bring to the client a proposal with the aim of generating interest) in proportion to the share of the product in the product package offered to the client. The time for simultaneous voicing of the bank’s proposals to a group of clients

during presentations to enterprises was normalized based on the average number of participants in a group presentation, as well as the above on-the-road time allocated to the product.

The third aspect discussed during the implementation of the model was the question of the completeness and frequency of accounting for all customer contact activities within the sales funnel. One proposed strategy was the creation of a unified information system for recording the above activities on a monthly basis. However, according to the testing results, this approach was found to be very costly, since it required significant time costs for the employees of the analytical department, or huge investments in IT. Instead, the project management decided to use a ready-made analytical factor analysis of the phased transformation of customer contacts into transactions, which determined the percentage of customers who were transferred to the next stage of the sales funnel. Based on the available percentage of factor analysis, management can present a “countdown” of the number of actions at each stage necessary to conclude a deal with a client, which was applied in the model, updated at least quarterly. As the integrated analytics of the omnichannel sales model develops, it will be possible to move to direct accounting of operations at each stage of the sales funnel.

In the process of analyzing the theoretical base and practical application cases, the following limitations (barriers) were identified that impeded the implementation of an omnichannel sales model and cost management of an omnichannel sales chain in banking:

A large number of products and processes needed to be reengineered and automatized during the implementation of the omnichannel approach, both from our own company and from partner companies in the sales process. Significant capital expenditures on the development and maintenance of software and the purchase of equipment can be quickly paid for only with large-scale work on a product or project. These product and process upgrades include:

- (1) A large number of IT systems are needed to account for various products. For example, even in one bank, sales of even the bank’s own products might be counted in different information systems. The exchange of information on the non-bank products sold by partner companies with the IT systems of these partners is carried out, as a rule, in offline mode with a certain frequency. Thus, support for the omnichannel model when outsourcing part of the functions is also significantly hampered.
- (2) The need to ensure a high degree of protection of information and customer accounts, especially with remote identification and services. This requires a centralized anti-fraud system covering all channels (Terrasoft 2019). The conservatism of certain clients and client segments (for example, Russian pensioners) using digital services wishing to receive documents on paper with live signatures must also be considered.
- (3) Product-centric (instead of customer-centric) cultures (Maat 2017) are needed.
- (4) Employees of different channels must be motivated to obtain results from sales in the implementation of their own KPI to achieve the planned targets and to receive a bonus. With omnichannel sales, it is important not only to take into account the contribution of each participant in the sales chain, but also, if possible, to avoid a double and triple accounting of bonuses for the same transaction, without going beyond the required overall profitability of the product’s business.

These aforementioned restrictions will determine future areas of scientific and practical research on the topic of increasing efficiency of sales of banking (and not only banking, but also other retail products) via the introduction of an omnichannel approach.

5. Conclusions

Centralized analysis and control of interaction with customers at all stages and in all channels allows banks to significantly increase their targeting and service flexibility, reducing the time to market for products. A complete comprehensive analysis of the entire sales funnel makes it possible to control their cost, selecting the most optimal omnichannel chains. In calculating the cost of sales, it is necessary

to take into account not only the direct costs of sales to customers who have made purchase transactions, but also all the losses throughout the whole sales funnel cycle, the costs of developing and maintaining information systems, and the costs of marketing and promotion.

As a result of this study, the main advantages of introducing an omnichannel model were identified, with the aim of improving management efficiency; the key factors for inclusion in the model were also identified, as well as the main barriers to implementation. The omnichannel model of interaction with customers will enable banks to simultaneously achieve several key goals of increasing their own business efficiency:

- (1) Sales growth due to an increase in the frequency of interaction with customers while minimizing the loss of “unsatisfied” customers at the stage of the transaction life cycle;
- (2) Improving the quality of customer service by providing access to products and services 24/7 and saving customers’ time;
- (3) Reduction of the specific costs of service per client (per product sold/service provided, as well as contact with the client during the interaction).

The “robo-advisors” used by banks are much cheaper than their human counterparts, and are accessible whenever and wherever the user needs their services. Introducing the omnichannel model, banks can accumulate and analyze information about customer behavior using big data technology. By managing data collected in various forms, such as text, audio, and video, banks seek to give customers valuable advice and provide customized suggestions. Customer relationship management (CRM) solutions can be used to integrate heterogeneous data into a single system.

One of the key tasks in introducing omnichannel approaches in the banking business is the integration of all IT platforms and solutions into a single centralized data repository (operations) that will allow for seamless interaction with the client, regardless of the product and channel. That is, the client should be able to carry out any purchase or service operation at a convenient time and place, and at any stage of communication. For this, the bank must ensure the availability of a unified accounting base of products, customers, accounts, and operations (for example, by CRM), monetizing the value of its analytics and increasing the value of its brand.

Another important point in the implementation of the model is the issue of interconnecting sales plans with a motivation system for employees in different channels. Accounting and incentive systems should motivate employees to work as a team while observing the strategic interests of the bank, which will avoid seller conflict of interests when initiating transactions and contacts with a client base. The proposed omnichannel sales cost management model can be used not only in banking, but also in other retail business formats, where management can collect detailed statistics and set up a factor analysis of the conversion through the sales funnel.

Author Contributions: Both authors contributed equally.

Funding: This research received no external funding.

Conflicts of Interest: The authors declare no conflict of interest.

References

- Centric Digital. 2017. 5 Realistic Strategies in Omni Channel Banking. July 21. Available online: <https://centricdigital.com/blog/customer-experience/5-realistic-strategies-in-omni-channel-banking> (accessed on 8 April 2019).
- Dube, Apramey, and Anu Helkkula. 2015. Service experiences beyond the direct use: Indirect customer use experiences of smartphone apps. *Journal of Service Management* 26: 224–48. [CrossRef]
- Jaakkola, Elina, Anu Helkkula, and Leena Aarikka-Stenroos. 2015. Service experience co-creation: Conceptualization, implications, and future research directions. *Journal of Service Management* 26: 182–205. [CrossRef]

- Klaus, Phil, and Bang Nguyen. 2013. Exploring the role of the online customer experience in firms' multi-channel strategy: An empirical analysis of the retail banking services sector. *Journal of Strategic Marketing* 21: 429–42. [CrossRef]
- Komulainen, Hanna, and Hannu Makkonen. 2018. Customer experience in omni-channel banking services. *Journal of Financial Services Marketing* 23: 99–190. [CrossRef]
- Komulainen, Hanna, Saila Saraniemi, Pauliina Ulkuniemi, and Marianne Ylilehto. 2018. End-customer value restructuring the financial service supply chain. *Marketing Intelligence & Planning* 36: 709–20.
- Koneva, Anna. 2019. Chto znachit "prodavat" vezde": Omnikanal'nyye prodazhi s pomoshch'yu Ekvida. July 30. Available online: <https://www.ecwid.ru/blog/how-to-make-ecwids-omnichannel-potential-work-for-you> (accessed on 7 August 2019).
- Maat, Jenny. 2017. Omni-Channel Banking Begins with an Outside-in Approach. August 22. Available online: <https://backbase.com/2017/08/22/omni-channel-banking> (accessed on 1 September 2019).
- Marketing Science Institute. 2016. Research Priorities 2016–2018. Available online: www.msi.org (accessed on 10 February 2019).
- Obilisetty, Sridhar. 2019. Omnichannel Banking Goes Beyond Seamless Transactions. Available online: <https://thefinancialbrand.com/73488/omnichannel-banking-data-customer-journey-experience> (accessed on 3 April 2019).
- Okorokov, Semon. 2016. Omnikanal'nost': Panatseya ot krizisa ili modnyy trend. June 1. Available online: <https://roem.ru/01-06-2016/225473/omnikalnost> (accessed on 9 April 2019).
- Retail Pragmatist. 2019. The Economics of Omni-Channel Retail—What Does Omni-Channel Mean? January 5. Available online: <http://www.retailpragmatist.com/economics-omni-channel-retail> (accessed on 12 April 2019).
- Rosman, Tobias. 2015. *Investigating Omni-Channel Banking Opportunities in Sweden: From a User Perspective*. Stockholm: KHT Royal Institute of Technology, School of Computer Science and Communication.
- Saghiri, Soroosh, Richard Wilding, Carlos Mena, and Michael Bourlakis. 2017. Toward a three-dimensional framework for omni-channel. *Journal of Business Research* 77: 53–67. [CrossRef]
- Sahoo, Debjani, and Sreejesh S. Pillai. 2017. Role of mobile banking servicescape on customer attitude and engagement: An empirical investigation in India. *International Journal of Bank Marketing* 35: 1115–32. [CrossRef]
- Sberbank. 2018. Annual Report, 2017. Available online: https://www.sberbank.com/common/img/uploaded/files/pdf/yrep/en/sberbank_annual_report_2017_eng.pdf (accessed on 1 April 2019).
- Serov, Eugene R. 2018. Managing of the net cost of omni-channel sales in credit organizations. *Problems of Modern Economics* 3: 188–92.
- Shaikh, Aijaz A., and Heikki Karjaluo. 2015. Mobile banking adoption: A literature review. *Telematics and Informatics* 32: 129–42. [CrossRef]
- Skan, Julian, James Dickerson, and Samad Masood. 2015. The Future of Fintech and Banking: Digitally Disrupted or Reimagined? Available online: www.accenture.com (accessed on 15 February 2019).
- Tam, Carlos, and Tiago Oliveira. 2017. Literature review of mobile banking and individual performance. *International Journal of Bank Marketing* 35: 1044–67. [CrossRef]
- Terrasoft. 2019. Omni-Channel Banking. Available online: <https://www.terrasoft.ru/financial-services/insights/omnikanalny-banking> (accessed on 11 April 2019).
- Tinkoff. 2018. Strategy Day, June. Available online: <http://finside.ru/wp-content/uploads/tinkoff-strategy-day-2018.pdf> (accessed on 7 April 2019).



© 2019 by the authors. Licensee MDPI, Basel, Switzerland. This article is an open access article distributed under the terms and conditions of the Creative Commons Attribution (CC BY) license (<http://creativecommons.org/licenses/by/4.0/>).

Article

Application of Diffusion Models in the Analysis of Financial Markets: Evidence on Exchange Traded Funds in Europe

Adam Marszk * and Ewa Lechman

Faculty of Management and Economics, Gdansk University of Technology, Narutowicza 11/12, 80-233 Gdansk, Poland; eda@zie.pg.gda.pl

* Correspondence: amarszk@zie.pg.gda.pl

Received: 14 January 2020; Accepted: 10 February 2020; Published: 14 February 2020

Abstract: Exchange traded funds (ETFs) are financial innovations that may be considered as a part of the index financial instruments category, together with stock index derivatives. The aim of this paper is to explore the trajectories and formulates predictions regarding the spread of ETFs on the financial markets in six European countries. It demonstrates ETFs' development trajectories with regard to stock index futures and options that may be considered as their substitutes, e.g., in risk management. In this paper, we use mathematical models of the diffusion of innovation that allow unveiling the evolutionary patterns of turnover of ETFs; the time span of the analysis is 2004–2015, i.e., the period of dynamic changes on the European ETF markets. Such an approach has so far rarely been applied in this field of research. Our findings indicate that the development of ETF markets has been strongest in Italy and France and weaker in the other countries, especially Poland and Hungary. The results highlight significant differences among European countries and prove that diffusion has not taken place in all the cases; there are also considerable differences in the predicted development paths.

Keywords: financial innovations; diffusion; exchange traded funds; stock index futures; stock index options; stock market indexes

1. Introduction

Over the last decades, dynamic changes across financial markets have included the introduction of innovative financial instruments that contribute to global financial diversity. The category of innovative financial instruments is highly heterogeneous, e.g., in terms of the rate of their expansion; exchange-traded funds (ETFs) are among the most rapidly expanding financial instruments. ETFs are funds structured to mimic the performance of selected financial assets, usually stock indexes. The difference between ETFs and conventional investment products (such as mutual funds) is that units of ETFs resemble, financial instruments such as listed equities or bonds because they are purchased and sold through stock exchanges. The growing popularity of ETFs, the increase in the sums involved and the rate of turnover are predominantly enhanced by low trading costs, low tracking errors, high liquidity and (in some countries) high tax efficiency (Agapova 2011; Madhavan 2016; Ben-David et al. 2017; Lettau and Madhavan 2018).

Until recently, ETFs were mainly considered as substitutes for index funds in passive investing strategies because of their similar features and users. However, a rising recognition and complexity of the products offered has resulted in increasing demand from different types of players in the financial markets. As a result, the shares of innovative funds have become substitutes not only for index funds but also for derivatives. To the best of our knowledge, there have been almost no empirical works covering the subject of switching between ETFs and stock index derivatives, although a theoretical background was provided by the framework suggested by Gastineau (2010).

The only exception is the analysis of the Asia-Pacific markets presented in [Marszk et al. \(2019\)](#)—due to different geographical coverage, it cannot be compared directly to the current study. In the recent years, there have been a number of studies devoted to the relationships between ETFs and futures but they have focused on particular attributes of selected instruments rather than market-broad analysis (e.g., [Liu and Tse 2017](#); [Oztekin et al. 2017](#); [Chang et al. 2018](#); [Wang et al. 2018](#); [Chang et al. 2019](#); [Jiang et al. 2019](#); [Wallace et al. 2019](#); [Liu et al. 2020](#)).

Even though the diffusion of financial innovations has been discussed in a number of publications in recent decades, most studies have focused on the banking sector (e.g., [Persons and Warther 1997](#); [Hayashi and Klee 2003](#); [Frame and White 2004, 2012](#); [Akhavain et al. 2005](#)). Earlier studies of innovations in the capital markets mostly concentrated on asset-backed securities or junk bonds (see, e.g., [McConnell and Schwartz 1992](#); [Molyneux and Shamroukh 1996](#); [DeMarzo and Duffie 1999](#)). Since the global financial crisis, this category of research has been marginalized due to a decreasing popularity of these instruments ([Philippas and Siriopoulos 2012](#)). The studies that have considered the diffusion of innovative financial products traded on exchanges (such as ETFs) have been relatively rare (e.g., [Lechman and Marszk 2015](#); [Hull 2016](#); [Marszk et al. 2019](#)). However, the current analysis differs from the previous studies because we empirically examine the diffusion of ETFs in relation to the other stock index instruments in a highly heterogeneous group of countries in two regions. Some attempts to outline the theory of ETF adoption have also been made by [Diaz-Rainey and Ibikunle \(2012\)](#), [Awrey \(2013\)](#) and [Blocher and Whaley \(2016\)](#), but the process of diffusion has not been discussed in these publications.

According to data published by the ETF research company, ETFGI, the value of assets that are globally managed by ETFs reached a value of almost 4.7 trillion USD at the end of 2018, and there were circa 6500 such funds available worldwide. In comparison, the global value of assets was 2.9 trillion USD at the end of 2015, and there were circa 6100 such funds; at the end of 2009 the corresponding figures were just over 1 trillion USD and fewer than 2000 ETFs. Nonetheless, in case of Europe, the substantial changes had taken place over 2004–2015, as it had been the period of the launch and rapid expansion of ETFs in terms of number, assets and turnover. However, the growth dynamics of the ETF markets (understood as increasing values of assets accompanied by an increased turnover rate) in different countries differed significantly. In Europe (here understood as the EU member countries; in other European countries, except for Switzerland, the ETF markets remain underdeveloped) their use is still low compared to other advanced economies such as the United States, Japan and South Korea. It is important to note that comparing most European ETF markets to their American or Far Eastern counterparts is problematic because ETFs have a longer history and wider recognition in these countries.

The main aim of this paper is to explore the trajectories and formulate forecasts regarding the spread of ETFs on the financial markets in selected European countries between 2004 and 2015: Germany, France, Spain, Italy, Poland and Hungary. Consequently, we exclusively analyze the EU member states: four countries with the most developed ETF markets in the examined time period (except for the United Kingdom, due to a lack of necessary data) and, for comparison, two countries in the Central and Eastern Europe with substantially underdeveloped ETF markets—we can thus examine radically different patterns of diffusion of ETFs. In order to reach the stated aim, we use a novel methodological approach to the analysis of financial markets—mathematical models of the diffusion of innovation based on the turnover data. We thus contribute to the present state of knowledge not only by addressing the role of ETFs among the index financial instruments in Europe, but also by showing the financial application of the diffusion models. Moreover, this is one of the first studies to present and examine ETFs and stock index derivatives as substitutes for risk management.

More specifically, we aim to:

- analyze financial innovation diffusion trajectories across selected European stock exchanges;
- provide long-term predictions of financial innovation development across the markets examined, in order to assess the probable path of ETF market development in Europe.

In order to do the above, we use monthly time series with ETF data from the economies selected between 2004 and 2015. This time period was selected due to the substantial pace of changes on the ETF markets in Europe, following their launch in the analyzed countries (the next years, since 2016 onwards, can generally be characterized as the period of stabilization and slower growth in terms of turnover of ETFs—moreover, in the case of some countries such as France or Spain, substantial decline could be noted; there were almost no ETFs traded in Europe prior to 2004).

This paper comprises five sections. Section 2 outlines the theoretical setting and presents some issues with regard to ETFs: their fundamentals, and how they compare with stock index derivatives. Section 3 outlines the methodological framework and presents the sources of data. Section 4 is devoted to the discussion of the results of the conducted empirical study; it is further divided into two parts: a presentation of introductory descriptive evidence related to the ETF market development, and a discussion of our key results obtained using diffusion models. Section 5 concludes the paper.

2. Theoretical Background

2.1. Basic Features of ETFs

In their basic form, exchange traded funds (ETFs) may be defined as baskets of securities (or other assets) traded on a stock exchange (comparable to equities of public corporations), typically with the intermediation of brokerage companies (Ferri 2009). ETFs are innovative financial instruments and they were introduced in the 1990s and 2000s. The units of ETFs closely replicate (i.e., track) the financial performance of certain financial assets, usually blue-chip or broad market indexes of the stock markets (Hehn 2005; Hill 2016). ETF shares (units) can be purchased and sold on the stock exchanges during their trading hours at prices determined by the interaction of demand and supply (Abner 2016; Investment Company Institute 2017). The prices of ETF shares remain typically at levels close to their net asset value (which is related to the prices of the assets tracked). There are two parts of the ETF market: the primary and secondary segments (Hill et al. 2015; Ben-David et al. 2018; Box et al. 2019). The shares of ETFs can be created and redeemed exclusively on the primary segment, as a result of operations including both the company that manages the fund (its sponsor) and financial institutions that act as authorized participants. In the case of physical ETFs, they involve the delivery of the assets underlying the fund in exchange for the shares of ETFs, and in the case of synthetic ETFs (the funds that employ derivatives, popular above all on the European markets) transactions involve cash. As a result of transactions on the primary market, which are a part of the arbitrage mechanism, ETF tracking errors (deviations in the returns on the units of ETFs from the returns on the tracked assets) are low in most cases. The secondary segment of the ETF market involves transactions on stock exchanges conducted by market participants (institutional or individual investors)—they include in particular the sale or purchase of ETF shares without any interaction with the managing company.

The rising recognition of ETFs in the last decade has generally been the result of the attributes they provide to investors compared to conventional financial instruments, particularly the sub-category of mutual funds with similar aims—index funds. These advantages stem from the mechanisms for the creation and distribution of ETFs. Their key benefits relative to index funds include: lower tracking errors and lower tracking costs (in some circumstances, index funds are more cost-efficient—this depends on the trading frequency and the investment period), higher liquidity (units of index funds are usually priced once a day and have daily buying/purchasing cycles) and greater tax efficiency in some countries (e.g., in the USA) (Agapova 2011; Investment Company Institute 2017; Piccotti 2018). It should not be forgotten that the expansion of ETFs in Europe can affect not only the financial sector but also non-financial companies—potential effects are not limited to the countries with the highest assets of locally listed ETFs, as other economies may also be affected through, e.g., cross-listing of the shares of ETFs (Alderighi 2020) or foreign assets held in the portfolios of ETFs (Baltussen et al. 2019); one of the possible consequences is the impact on the probability of bankruptcy of the companies (Kovacova et al. 2019) as the level of the development of the local ETF market can become one of the

possible determinants of insolvency. However, this issue remains substantially understudied, both theoretically and empirically.

2.2. ETFs Compared to Stock Index Derivatives

Exchange traded funds, stock index futures and stock index options may be regarded as competing products within the category of (portfolio basket) index financial instruments. Together with a few other instruments, they constitute the equity index arbitrage complex—a group of related financial instruments based on common underlying assets (usually a basket of assets). This is a group of instruments with related values because of the similarity of their underlying financial assets (Gastineau 2010). The underlying assets are usually stock market indexes or stock baskets determined by the index rules. The equity index arbitrage complex consists of three instrument categories (less commonly used instruments have been omitted):

1. Traditional securities: baskets of equities and ETFs;
2. Symmetric derivatives: stock index futures and equity/index swaps;
3. (Non-symmetric) convex instruments: stock index options.

In this classification, ETFs are included in the first category because they are combinations and extensions of the underlying traditional assets, not because they lack innovative features. The values of symmetric instruments are straightforward functions of the prices of the underlying assets, whereas the prices of convex instruments do not move proportionately.

The following discussion regards three groups of instruments traded on exchanges: ETFs, stock index futures and stock index options. Stocks, the most basic instruments, are not discussed. Instruments which belong to an arbitrage complex are perceived by investors as substitutes, not only because of the similarity of the underlying assets but also because of the potential for (usually limited) arbitrage profits. This means that their prices are related. Treating the arbitrage complex as an object of analysis is a suitable way to perform research concerning modern financial markets, as feedback between increasing trading volumes and decreasing trading costs on the one hand and arbitrage complexes on the other has been observed on most of the world's stock exchanges (Gastineau 2010).

Before the current dynamic development of the ETF market, these innovative instruments were considered as alternatives to futures or options, mostly for short- and long-term risk management by large investors. Gastineau (2010) presents the results of a preliminary comparison based on data from the US market (the assets tracked were S&P 500 stocks). The key characteristic compared is the cost of these two alternatives. The costs of ETFs for risk managers result from the cost of gathering the stocks in a creation basket (it is assumed that transactions are conducted on the primary ETF market due to their size) or opposite transactions—commission fees, management fees and market impact. In the case of futures, the main costs are roll risk (the cost of extending the contracts after they end) and market impact. As a result, futures seem to be a better choice for short-term risk management, whereas ETFs are beneficial in the long term due to their lack of rolling expenses.

In recent years, ETFs have become increasingly popular alternatives to futures and options, not only as risk management tools for specific categories of investors but also for a wider group of market participants. The reasons for this change in the financial landscape can be traced back to the financial crisis of 2008 and regulatory decisions made in its aftermath, which were aimed at reducing systematic shock risks (Goltz and Schröder 2011; Arnold and Lesné 2015). As a result of the increased cost of capital for investment banks, growing operational (e.g., improved transparency) and capital requirements, and liquidity constraints—mainly linked to the Basel III regulations (Madhavan et al. 2014; Madhavan 2016), the cost of traditional instruments such as futures or options grew and ETFs became relatively more cost-effective, for example in obtaining long-term exposure. Moreover, because of the high level of competition among ETF providers and economies of scale, the costs of investments in ETFs, especially in equity index ETFs (the closest substitutes for index futures and options), have been significantly declining (Arnold and Lesné 2015). To sum up,

ETFs and stock index derivatives can be perceived as alternatives in certain fields of risk management (Hill and Mueller 2001; Madhavan 2016; Arunanondchai et al. 2019).

The differences between ETFs and stock index futures and in particular their relative advantages and disadvantages will now be described. Despite their different features, which make direct comparisons difficult, most of the relative advantages and disadvantages of futures with respect to ETFs which are discussed below also apply to options (as derivatives traded on regulated exchanges, which in many cases may be alternatives to futures, and even more importantly to ETFs (Thomsett 2016)).

The similarities between ETFs and stock index futures include (Goltz and Schröder 2011; Arnold and Lesné 2015; Marszk et al. 2019):

- identical trading venues—most turnover occurs on stock exchanges,
- multiple market participants,
- intra-day pricing (on exchanges),
- high liquidity,
- minimal counterparty risk.

Table 1 presents some selected main features which distinguish ETFs from stock index futures. The key difference, which influences the relative costs of these two categories of instruments, lies in the rolling costs of futures contracts, i.e., the costs of entering a new contract after the expiry of the previous one, which involve both explicit costs (trading commissions and bid-ask spreads) and potential mispricing (Madhavan et al. 2014; Arnold and Lesné 2015). The main relative advantages of futures can be observed in the following features: the capital required, leverage, and short sale possibilities. The strengths of ETFs are higher accessibility, wider product ranges, minimal management requirements prior to exiting, no predefined maturity and easier foreign investment. To sum up, similarly to the use in risk management discussed in the preceding paragraphs, even for the broad investing audience, ETFs may be considered as more efficient long-term investment instruments, whereas futures are regarded as more suitable short-term choices (Eurex 2016). It should be noted, however, that the final choice depends not only on the holding period but also on the investment strategy. According to the results of a study conducted by the CME Group (2016), in the case of leveraged or short sale positions index futures are relatively more beneficial, regardless of the holding period.

Table 1. Main differences between ETFs and stock index futures. Own compilation based on Hamid and Edrosolan (2009), Madhavan et al. (2014), Arnold and Lesné (2015), CME Group (2016), Madhavan (2016), Arunanondchai et al. (2019), Marszk et al. (2019).

Feature	ETFs	Stock Index Futures
Accessibility	Very high, due to small notional requirements. Operationally simple in most cases	Small notional requirements. Operationally complicated (e.g., pricing)
Product range	Very broad. Many asset classes	Most major equity indexes
Required capital	Full upfront payment	Only margin (a notional fraction of the investment needs to be posted)
Position management	Minimal (may include reinvestment of dividends)	Margin and cash flow management, contract rolling
Maturity	Open-ended	Predefined (usually one or three months)
Leverage	Only in the case of leveraged ETFs	Available, usually very high
Short sales of securities	May be limited (with the exception of special ETF classes, e.g., inverse ETFs)	Investors may use futures to obtain short exposure
Positions in foreign assets	No need to manage foreign exchange component	Foreign exchange management necessary

It should be underlined that the framework presented above only applies to equity ETFs, and many more types of these instruments are currently available, such as fixed income and commodity ETFs. However, despite the increasing heterogeneity of ETFs, equity ETFs (based on the equity market, usually stock market indexes) are still by far the largest category.

3. Materials and Methods

3.1. Innovation Diffusion Models

To achieve the main aims of this study, we adopted a methodological framework allowing for examination of the evolution over time of the processes observed across the financial systems including, e.g., ETF diffusion. For that reason, apart from the usual descriptive statistics, we employed innovation diffusion models (presented in, inter alia, Geroski 2000; Rogers 2010; Lechman 2015); they may be used to approximate ETF diffusion trajectories and modeled projected future ETF development patterns. A similar approach is presented in a study by Lechman and Marszk (2015), who study ETF diffusion paths in chosen countries.

In the main part of our empirical analysis, in order to reveal ETF market development patterns, we follow the approach of, among others, Mansfield (1961) and Dosi and Nelson (1994), who adopted the concept of evolutionary dynamics. It can be expressed mathematically in the form of a logistic growth function, which may further be presented as an ordinary differential equation (Meyer et al. 1999):

$$\frac{dY_x(t)}{dt} = \alpha Y_x(t). \quad (1)$$

If $Y(t)$ denotes the level of variable x , α is a constant growth rate and t denotes time, then Equation (1) explains the time pattern of $Y(t)$. Moreover, the introduction of e to Equation (1) leads to its reformulation as:

$$Y_x(t) = \beta e^{\alpha t}, \quad (2)$$

or alternatively:

$$Y_x(t) = \alpha \exp \beta t, \quad (3)$$

with notation parallel to the one in Equation (1) and β representing the starting level of x at $t = 0$. Presented simple growth model is due to its assumptions being pre-defined as exponential. Therefore, it assumes that x will continue to grow infinitely in a geometric progression. Arbitrary extrapolation of $Y_x(t)$ within an exponential growth model can result in improbable predictions, since systems do not grow infinitely because of their constraints (Meyer 1994). For that reason, to address the issue of 'infinite growth', Equation (1) can be extended by adding a 'resistance' parameter (Kwasnicki 2013). This change imposes an upper 'limit' to the model, thus giving the original exponential growth curve a shape that is sigmoid. Consequently, the revised version of Equation (1) becomes a logistic differential function:

$$\frac{dY(t)}{dt} = \alpha Y(t) \left(1 - \frac{Y(t)}{\kappa} \right), \quad (4)$$

with following notation—the parameter labeled as κ denotes the upper asymptote imposed, which arbitrarily restricts the increase of the variable Y .

As shown above, introducing a resistance parameter to exponential growth leads to trajectory that can be described as S-shaped. Equation (4), the 3-parameter logistic differential equation, can also be presented in another way, using a logistic growth function which takes non-negative values:

$$N_x(t) = \frac{\kappa}{1 + e^{-\alpha t - \beta}}, \quad (5)$$

or, alternatively:

$$N_x(t) = \frac{\kappa}{1 + \exp(-\alpha(t - \beta))}, \tag{6}$$

where $N_x(t)$ represents the level of variable x in certain time period t . Other parameters in Equations (5) and (6) stand for the following: κ is the upper asymptote, which determines the limit of growth and is also labeled ‘carrying capacity’ or ‘saturation’; α is the growth rate, which determines the speed of diffusion; and β stands for the midpoint, which shows the exact moment in time (T_m) when the logistic pattern reaches 0.5κ . Nonetheless, interpretation may be facilitated by replacing α with a parameter known as ‘specific duration’, and defined as $\Delta t = \frac{\ln(81)}{\alpha}$. With Δt , it becomes easy to approximate the time necessary for x to increase from $10\%\kappa$ to $90\%\kappa$. Moreover, the midpoint (β) denotes the point in time at which the logistic growth begins to level off. Finally, mathematically, it is the inflection point of the logistic curve. Incorporating Δt and T_m into Equation (6) produces:

$$N_x(t) = \frac{\kappa}{1 + \exp\left[-\frac{\ln(81)}{\Delta t}(t - T_m)\right]}. \tag{7}$$

In our research, we aim to use the methodological framework for innovation diffusion models briefly presented above. In the first part of the analysis, we assume that the growing value of ETF unit turnover can be regarded as diffusion of ETFs on financial markets in the examined countries. Nevertheless, in the core part of our study, we assume that the process of the growing ETF share of the total turnover of comparable investment options (in the equity index arbitrage complex) is comparable to the process of diffusion of innovative products and services across heterogeneous socio-economic systems. We assume that ETFs are innovations which due to a ‘word of mouth’ effect (Geroski 2000) and emerging network effects are progressively adopted by growing numbers of investors (who may also be described as ‘users’ of ETFs). We also rely on a basic assumption that investors (users) in certain type of financial innovations (here, ETFs) may freely contact ‘non-investors’ (‘non-users’), i.e., people either not using ETFs before or previously choosing other similar options, which leads to adoption by this group.

In short, we assume that ETFs diffuse on financial markets in the analyzed countries and gain a growing share of the total turnover of similar investment options (apart from ETFs, stock index futures and stock index options (Gastineau 2010; Madhavan 2016; Arunanondchai et al. 2019; Marszok et al. 2019)). In the fundamental specification of the 3-parameter logistic growth model as defined in Equation (6), we presume that $N_x(t) = \text{ETF}_i(t)$ represents changes in the ETF share of the total turnover of comparable investment options over time t in country i . Put differently, it describes changes in country i ’s level of ETF financial market penetration. The parameter κ is represented as κ_i^{ETF} , which is the ceiling (upper asymptote/system limit) on the process of ETF diffusion on financial markets. The estimated parameter κ_i^{ETF} denotes the potential ETF share of the total turnover of comparable investment options on the financial market in country i . However, there is the strict assumption that the trajectory of ETF diffusion (development) follows the sigmoid pattern generated by the logistic growth equation.

Next, the parameter α (as in Equation (6)) is represented as α_i^{ETF} , which is the speed of ETF diffusion on the financial market in country i . Hence, the estimated parameter α_i^{ETF} shows how fast the ETF share of the total turnover of comparable investment options is increasing on the financial market selected. Moreover, using parameter α_i^{ETF} we calculate the ‘specific duration,’ defined as $\Delta t = \frac{\ln(81)}{\alpha_i^{\text{ETF}}}$, which represents the time needed to pass from $\kappa_i^{\text{ETF}} = 10\%$ to $\kappa_i^{\text{ETF}} = 90\%$.

The parameter β is expressed as β_i^{ETF} , and its estimated value denotes the midpoint T_m^{ETF} , which indicates the exact time when 50% of κ_i^{ETF} is reached. Hence, T_m^{ETF} represents the time (year/month) when the process of ETF diffusion reaches the half-way point if we assume that it is heading toward κ_i^{ETF} .

Thus, the modified specification of Equation (6) is:

$$ETF_i(t) = \frac{\kappa_i^{ETF}}{1 + \exp(-\alpha_i^{ETF}(t - \beta_i^{ETF}))}, \quad (8)$$

with notation as explained above.

The parameters in Equation (8) can be estimated using not only ordinary least squares (OLS) but also maximum likelihood (MLE), algebraic estimation (AE) or nonlinear least squares (NLS). Nonetheless, as [Satoh \(2001\)](#) suggests, NLS returns the best predictions, as its estimates of standard errors (of κ_i^{ETF} , α_i^{ETF} , β_i^{ETF}) are more valid than those returned using the other methods. Adopting NLS allows time-interval biases, which occur in the case of OLS estimates ([Srinivasan and Mason 1986](#)), to be avoided. However, NLS has the disadvantage that estimates of the parameters may be sensitive to the initial values of the time-series adopted. Finally, it should be emphasized that the construction of the utilized model hinders inclusion of the explanatory variables. However, the issue of the factors that affect the diffusion of ETFs was analyzed using different methodologies—the results were presented in, *inter alia*, [Lechman and Marszk \(2015\)](#) and [Marszk et al. \(2019\)](#).

3.2. Data

Our research covers stock exchanges in six European countries: two countries in the Central and Eastern Europe (CEE) region—Poland and Hungary; another four EU countries with the longest history of ETF trading—France, Italy, Germany and Spain. Our analysis covers the Euronext exchange considered as a whole (due to data availability), and thus (in addition to France) also includes The Netherlands, Belgium and Portugal. However, most of the turnover is reported to be in the French segment and so we decided to consider this exchange as if it was located in France. Consequently, we also used other indicators for France.

The time span of the analysis is 2004–2015. It was selected due to the high rate of changes on the ETF markets in Europe, following their launch in the analyzed countries. The beginning of this period was chosen due to the fact that there were almost no ETFs traded in Europe in 2003 or earlier. The selected end of the time period of analysis is 2015 as since 2016, the changes have been less significant. The time coverage is also a result of data availability. For the period 2004–2015 a balanced data set is available for most of the countries included in the analysis, while for the CEE countries, the time span of the analysis is shorter as ETFs were launched there later than in the advanced European economies.

The financial instrument databases used in the study are the dataset provided by the World Federation of Exchanges ([World Federation of Exchanges 2017](#)), datasets provided by the selected stock exchanges and reports published by these institutions. The most important financial indicators used are the turnover values (in USD millions) on the stock exchanges of the instruments selected: ETFs, stock index options and stock index futures. Monthly data are used.

Due to a lack of reliable data on the turnover of stock index futures and options on the main stock exchange in the United Kingdom (caused by changes in the organizational structure of the London Stock Exchange Group), it was excluded from the analysis.

4. Results

4.1. Exchange Traded Fund Market Development: Preliminary Evidence

Our investigation of the development of the ETF markets starts with an analysis of summary statistics on the key changes in two measures: the turnover value and the percentage share of the total turnover of index financial instruments (see [Table 2](#)).

Table 2. Summary statistics for exchange traded funds, stock index options, stock index futures and total index financial instruments. Monthly data for 2004–2015. For ETFs, the periods of analysis are: Poland, 2010m9–2015m12; Hungary, 2007m1–2015m12; Italy, 2004m1–2015m12; Spain, 2006m7–2015m12; Germany, 2004m1–2015m12; and France, 2004m1–2015m12. The number of ETFs varies across time periods and countries.

Statistics	Poland				Hungary			
	Turnover on Local Stock Exchanges (in million USD)							
	ETFs	Stock Index Options	Stock Index Futures	Total Index Financial Instruments	ETFs	Stock Index Options	Stock Index Futures	Total Index Financial Instruments
# obs.	64	144	144	144	132	132	132	132
Min	0.90 (2012m11)	29.14 (2004m7)	1041.05 (2004m7)	1070.2 (2004m7)	0.0	0.0	9.2 (2015m5)	10.08 (2015m7)
Max	15.79 (2011m8)	1187.1 (2011m3)	15,820.6 (2008m1)	16,274.5 (2008m1)	7.6 (2007m4)	9.2 (2006m8)	1015.6 (2006m5)	1015.6 (2006m5)
Mean	5.5	336.2	6422.6	6761.30	0.60	0.10	244.9	245.7
Absolute change in value (pp)	0.76	184.05	3220.6	3408.8	−5.6	0.0	−172.7	−0.25
Average monthly dynamic	100.3	101.1	100.7	100.7	48.6	66.8	97.9	97.9
Share of Total Turnover of Index Financial Instruments on Local Stock Exchanges [%]								
	ETFs	Stock Index Options	Stock Index Futures	-	ETFs	Stock Index Options	Stock Index Futures	-
# obs.	64	144	144	-	132	132	132	-
Min	0.02 (2012m11)	1.6 (2008m4)	86.01 (2008m4)	-	0.0 (multiple periods)	0.0 (multiple periods)	77.9 (2015m)	-
Max	0.39 (2015m4)	13.9 (2013m8)	98.4 (2013m8)	-	22.01 (2015m5)	1.4 (2006m8)	100 (multiple periods)	-
Mean	0.08	5.05	94.9	-	0.55	0.02	99.4	-
Absolute change in share (pp)	0.05	1.9	−2.00	-	−0.25	0.0	−0.89	-
Average monthly dynamic	101.4	100.4	99.9	-	39.7	60.7	99.9	-
Italy				Spain				
Turnover on Local Stock Exchanges (in million USD)								
	ETFs	Stock Index Options	Stock Index Futures	Total Index Financial Instruments	ETFs	Stock Index Options	Stock Index Futures	Total Index Financial Instruments
# obs.	144	144	144	144	114	144	144	144
Min	246.4 (2004m5)	9038.99 (2011m12)	32,881.4 (2009m2)	48,685.7 (2009m2)	131.2 (2012m8)	1134.1 (2012m1)	28,439.7 (2012m2)	32,317.4 (2004m8)
Max	13,435.2 (2015m3)	53,337.8 (2007m3)	178,067.9 (2007m3)	234,279.7 (2007m3)	3397.5 (2008m1)	16,971.7 (2008m1)	169,693.3 (2007m11)	183,875.7 (2007m10)
Mean	5669.7	22,329.0	78,508.4	106,507.1	630.5	5764.6	74,557.7	80,821.5
Absolute change in value (pp)	8306.9	13,222.2	64,909.3	86,438.5	779.1	3950.7	33,361.5	38,333.1
Average monthly dynamic	102.3	100.5	100.6	100.6	101.3	100.6	100.4	100.5

Table 2. Cont.

Share in Total Turnover of Index Financial Instruments on Local Stock Exchanges [%]								
	ETFs	Stock Index Options	Stock Index Futures	-	ETFs	Stock Index Options	Stock Index Futures	-
# obs.	144	144	144		114	144	144	-
Min	0.27 (2004m3)	10.7 (2014m12)	63.6 (2007m10)		0.14 (2007m9)	81.6 (2011m1)	81.6 (2012m12)	-
Max	13.7 (2012m1)	32.3 (2007m10)	83.3 (2014m12)		2.2 (2015m7)	96.8 (2012m12)	96.8 (2011m1)	-
Mean	5.6	20.9	73.4		0.75	7.1	92.3	-
Absolute change in share (pp)	5.2	-3.07	-2.1		1.04	1.6	-2.9	-
Average monthly dynamic	101.7	99.8	99.9		101.3	100.1	99.9	-
Germany				France				
Turnover on Local Stock Exchanges (in million USD)								
	ETFs	Stock Index Options	Stock Index Futures	Total Index Financial Instruments	ETFs	Stock Index Options	Stock Index Futures	Total Index Financial Instruments
# obs.	144	144	144	144	144	144	144	144
Min	2549.1 (2004m9)	259,180.4 (2004m12)	550,142.9 (2004m2)	823,511.8 (2004m7)	810.6 (2004m9)	44,421.9 (2015m11)	204,785.8 (2004m8)	269,320.8 (2015m11)
Max	44,323.2 (2011m8)	2,830,918 (2008m1)	3,993,353 (2008m1)	6,852,531 (2008m1)	26,980.5 (2011m8)	726,885.4 (2007m11)	1,059,843 (2008m1)	1,725,926 (2008m1)
Mean	14,351.3	1,161,163	1,781,525	2,957,040	9170.3	266,211.7	485,718.8	761,100.9
Absolute change in value (pp)	14,556.7	979,971.1	1,747,945	2,742,473	16,803.99	-168,972	-33,997.2	-186,165
Average monthly dynamic	101.0	100.9	100.9	100.9	101.7	98.9	99.9	99.6
Share of Total Turnover of Index Financial Instruments on Local Stock Exchanges [%]								
	ETFs	Stock Index Options	Stock Index Futures	-	ETFs	Stock Index Options	Stock Index Futures	-
# obs.	144	144	144	-	144	144	144	-
Min	0.22 (2004m9)	24.06 (2004m12)	49.4 (2015m7)	-	0.13 (2004m9)	16.5 (2015m11)	49.5 (2004m8)	-
Max	0.89 (2011m7)	50.06 (2015m7)	75.6 (2004m12)	-	6.4 (2015m12)	50.3 (2004m8)	78.7 (2015m5)	-
Mean	0.48	38.6	60.9	-	1.4	33.9	64.5	-
Absolute change in share (pp)	0.03	-0.31	0.27	-	6.00	-28.7	22.7	-
Average monthly dynamic	100.0	99.9	100.0	-	102.0	99.3	100.2	-

In the time period analyzed, there were only two countries in the CEE region where ETFs were listed on the local stock exchanges: Poland and Hungary. In Poland, the highest values of ETF turnover were reached several months after their launch in September 2010, in August 2011 (see Table 2 and Figure A1 in the Appendix A). However, in 2012 turnover severely declined and reached a minimum level of only \$0.9 million USD in November 2012. From 2013 to 2015, trading in ETFs was still at a rather low level. However, in April 2015, ETFs reached their maximum share of the total market: 0.39%, which was mostly caused by a one-month spike in ETF trading (yet it was still one of the lowest shares among the countries considered). In Hungary, ETFs were launched much earlier than in Poland (in 2007) but their turnover was significantly lower (a mean monthly value of \$0.6 million USD compared to \$5.5 million USD in Poland). As in Poland, the highest turnover values were observed soon after their introduction. However, in terms of ETF market share, the highest value in Hungary was reached

(as in the Polish market) near the end of the time period analyzed, in May 2015 (see Figure 1). In contrast to the Polish exchange, the turnover of other related financial instruments (stock index futures and options) on the Hungarian market was extremely low: in most months there were almost no transactions in options and the value of futures trading was steadily declining. As a result, the mean turnover values in Hungary were minimal in comparison to the other stock exchanges considered. The very low turnover of ETFs in both Poland and Hungary was mostly caused by the low number of such financial products. In Poland, the number of ETFs grew from 1 to 3 (yet only one of them was listed exclusively in Poland and it accounted for the majority of turnover; the other two ETFs were cross-listed). In Hungary, there was only one ETF listed between 2007 and 2015 and it had a minimal turnover. The lack of further development was caused by a number of factors, including a lack of awareness of ETF features among market participants and the relatively small size of the financial markets, which limited the possibility of gaining benefits from the larger scale of offerings provided by ETF managers.

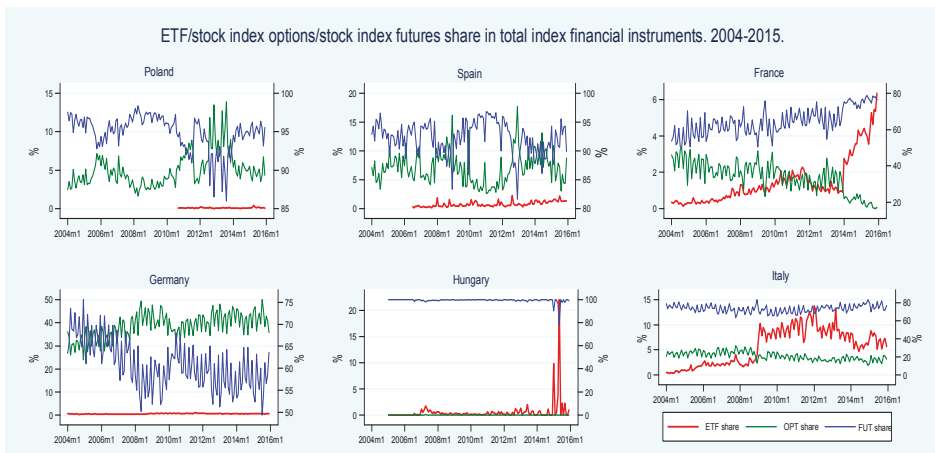

Figure 1. ETFs, stock index options and stock index futures—share of total turnover of index financial instruments. 2004–2015 (monthly time series). Left-hand Y axis—ETF share of total index financial instruments; right-hand Y axis—stock index options and stock index futures share of total index financial instruments.

In the four advanced EU countries selected, the only country with no ETFs listed at the beginning of the time period analyzed was Spain (ETFs were launched in Spain in July 2006). In terms of ETF turnover, in Italy growth of the ETF market was somewhat stable and the highest values were reached near the end of the time period. In France and Germany, ETF turnover grew until 2011, when it sharply declined, which may be explained by the eurozone crisis and falling stock prices (in the other three advanced EU economies a decline in ETF turnover in 2011 was also observed but it was relatively weaker (see Figure A1 in the Appendix A)). After 2011, turnover in France began to grow, whereas in Germany it was stable. The Spanish ETF market developed in a different way. After much variability until 2011, it entered a stage of stability between 2012 and 2013, and from the end of 2013 it started growing. This shows that the development of the ETF markets in these countries was to some extent shaped by similar determinants (e.g., the euro-zone crisis), although there were also some country-specific factors despite the high level of financial market integration.

Regarding ETF market shares, some substantial differences between the four countries can be noticed (see Table 2 and Figure 1). In Spain and Germany, the market share of ETFs was very low over the whole period. The case of Germany is particularly interesting. The mean value of ETF turnover in this country was the highest among all the countries analyzed and one of the highest in the world. Nevertheless, their average market share was the second-lowest (it was only lower in Poland), which shows that the role of ETFs in Germany was negligible compared to that of other index financial instruments. In both France and Italy, the market share of ETFs increased considerably: in France particularly from 2014, and in Italy from 2009. The mean market share value of ETFs in Italy was the highest of all the countries under study (5.6%), yet was still much lower than the shares of the other index instruments. The rapid development of the Italian ETF market may to a large extent be explained by the acquisition of the Italian stock exchange by its British counterpart, which is one of the largest in Europe in terms of the number and turnover of ETFs. The two markets have been integrated in some areas, which considerably boosted the Italian stock exchange's growth opportunities.

In the remainder of this study, we will use the market share as the indicator of ETF market development, as changes occurring in ETF markets should not be viewed in isolation but instead put in a broader context, thus showing the position of these innovative financial products in the financial system. Our preliminary analysis of changes occurring in the ETF markets will be expanded in the next sections—we will attempt to analyze the main features of the ETF diffusion process and predict its trajectories.

4.2. Exchange Traded Funds: Diffusion Models

As an aim of this study is to provide in-depth insight into the development process of ETFs across countries, we adopt a logistic growth model (for details, see Section 3) because use of this type of model allows the development trajectories of different variables in economic systems to be approximated and evaluated. Moreover, it allows the characteristic phases of the process of diffusion to be distinguished, such as the early diffusion phase, take-off, the exponential growth phase and saturation (maturity phase). Through the early diffusion stage, the number of contacts between adopters and non-adopters of a given innovation is still small, which may hinder its dissemination and so in this stage of diffusion the process is still reversible. However, under favorable conditions, easy contacts allow a domino effect to come into play and hence diffusion may speed up. Driven by various market forces, reductions in the cost of adopting innovations and multiple applications and uses of them, the number of new-users can rapidly increase and the curve takes off. It then enters a fast diffusion phase, when the diffusion process usually proceeds exponentially. Finally, a maturity (stabilization) stage is reached, during which the pace of diffusion again becomes slow and no substantial growth in the number of new users of the innovation is reported. In addition to revealing these phases, a simple logistic growth model returns good forecasts of future development (Kucharavy and Guio 2011).

Following the above-mentioned approach and using monthly time series for the period 2004–2015, we develop logistic growth patterns and estimate parameters (see Section 3) representing the ETF share of total index financial instrument turnover for each country individually. The results of our analysis are presented in Figure A2 in the Appendix A, which shows that the current and predicted ETF share diffusion paths, and in Table 3, which summarizes the country-wise logistic growth model estimates.

The graphical evidence presented in Figure 1 suggests that ETF diffusion patterns in some countries (i.e., growing ETF shares) may be well described by the logistic (sigmoid) growth trajectory. In some cases, the characteristic phases of the S-shaped path can be distinguished (also see the analysis for other countries in Lechman and Marszk (2015)). Initially slow changes in the ETF share of total turnover of index financial instruments are followed by a sudden take-off and then the ETF share pattern enters the rapid growth phase. However, it is important to note that the shapes of the ETF share diffusion paths across the countries examined are different and so they need special attention.

Table 3. Diffusion of exchange traded funds (as share of total turnover of index financial instruments). Logistic growth model estimates. 2004–2015 (monthly time series). Poland—data from 2010m9; Hungary—data from 2005m1; Spain—data from 2006m7.

Parameter	Poland	Hungary	Italy
κ_i^{ETF} (ceiling/upper asymptote)	0.087	97,207	8.56
Tm_i^{ETF} (β_i^{ETF}) (midpoint)	397,133.9	1062	52.9
α_i^{ETF} (rate of diffusion)	−2606.7	0.013	0.113
Δt_i^{ETF} (specific duration)	−0.002	339.2	38.7
R^2 of the model	0.00	0.075	0.76
# of obs.	64	130 (outliers excluded)	144
Parameter	Spain	Germany	France
κ_i^{ETF} (ceiling/upper asymptote)	500,100.2	0.585	7,755,333.6
Tm_i^{ETF} (β_i^{ETF}) (midpoint)	1,175,6.2	−3.94	777.3
α_i^{ETF} (rate of diffusion)	0.012	0.026	0.023
Δt_i^{ETF} (specific duration)	354.4	169.8	194.2
R^2 of the model	0.411	0.27	0.789
# of obs.	114	144	144

The picture which emerges from analysis of the ETF share in the two selected CEE countries—Poland and Hungary—differs radically from that for other countries. As already mentioned in the previous section, in neither Poland nor Hungary did ETFs gain much popularity and their share of total turnover remained extremely low over the time period analyzed. In Hungary, the growth of the ETF share of total turnover was minimal and its role in shaping the financial market was negligible. In Poland, a diffusion of ETFs across the domestic financial market was reported but still their role and share of the total turnover was marginal. It should be noted that between 2004 and 2015, the ETF share of the total turnover was close to zero. This leads to the conclusion that in both Hungary and Poland a diffusion of ETFs did not take place and so logistic growth models should not be applied. Table 3 presents the estimates of logistic growth models for Poland and Hungary, but as in both cases the R^2 of the models is zero, the parameters returned are misleading and inconclusive.

Finally, we discuss the results of the analysis of ETF diffusion for the four developed financial markets selected: Italy, Germany, France and Spain. In Germany, a diffusion of ETFs on the domestic financial market was not observed and ETF market penetration remained below 1%. As in the cases of Hungary and Poland, the logistic growth model estimates are not reliable. Despite the fact that the R^2 of the model is 0.27 (see Table 3), the value returned for the midpoint (Tm) is negative and so cannot be treated as valid. The situation in Spain is analogous, with a very low ETF share of total turnover during the time period examined. At the end of 2015, Spain was still located in the early diffusion stage, and as a result reliable estimates of a logistic growth model are not possible (the logistic growth parameters returned cannot be treated as valid).

In the other two advanced European economies—France and Italy—the ETF share was relatively high between 2004 and 2015. In both cases, the ETF diffusion patterns take off into self-sustaining growth after the early diffusion stage, during which increases in the ETF share were slow. In the case of Italy, the specific take-off occurred relatively early compared to the other economies examined. It should be noted that between June and July 2008 the ETF share almost doubled (from 1.8% to 3.4%) and the take-off took place shortly afterwards—between the middle of December 2008 and January 2009, when the ETF share increased from 3.7% to 8.0%. All the parameters returned from the logistic growth model estimates for Italy are statistically significant. The R^2 of the model is about 0.76, which implies a good fit between the empirical data and the theoretical model. Even though the R^2 of the model is low, there are no obvious misspecifications as the diffusion of ETFs is relatively well described by the logistic growth trajectory. The upper asymptote is estimated as $\kappa_i^{\text{ETF}} = 8.56\%$. The estimated midpoint

is $Tm_1^{ETF} = 52.9$. The rate of diffusion is $\alpha_1^{ETF} = 0.113$ and $\Delta t_1^{ETF} = 38.7$, which can be interpreted as the number of months required to pass from 10% to 90% of κ_1^{ETF} .

For France too, the diffusion of ETFs is well described by the logistic growth trajectory, despite the fact that in this case the early diffusion stage was relatively long. The take-off into the exponential growth phase did not happen until between the middle of December 2013 and January 2014, when the ETF share of total turnover grew abruptly. Even though the diffusion of ETFs (in terms of market share) on the French financial market is well approximated by the logistic growth pattern, the parameters estimated for the logistic growth model are not valid. The upper asymptote (ceiling) is reported as $\kappa_1^{ETF} = 7,755,333$, which is a definite overestimation.

Regarding the process of ETF diffusion in our country sample, the eight economies can be divided into two groups. The first group encompasses two countries—France and Italy—where an early diffusion stage was followed by a take-off into an exponential growth phase along a sigmoid trajectory. These two countries managed to leave the early diffusion stage, during which ETF share growth was slow and spasmodic, and take off into rapid growth. In the other four countries, the ETF share did not leave the early diffusion stage and remained virtually locked at a low level.

This empirical analysis of ETF diffusion trajectories can be enriched by providing additional specifications of the predicted development of ETFs across the economies selected. Table 4 summarizes the predicted country-specific ETFs diffusion paths, and Figure A2 in the Appendix A portrays them graphically. Fixing the critical level of the upper asymptote (κ_1^{ETF}) at 5%, 7.5%, 10%, 15%, 20%, 25% and 30%, we predict logistic growth model parameters under the strict assumption that ETF market development will follow an S-shaped trajectory.

For Hungary, with κ_1^{ETF} fixed at 5% the predicted Tm_1^{ETF} is June 2027 and the ‘specific duration’ forecast is about 320 months, i.e., more than 26 years. The predicted rate of diffusion is 0.014, which implies that the speed of ETF diffusion will be rather low in Hungary. The forecasts for higher κ_1^{ETF} show even more distant midpoints and they cannot be treated as being very reliable (and also because of the low R^2 of the models).

Italy has already reached the levels of $\kappa_1^{ETF} = 5\%$, 7.5% and 10%. With κ_1^{ETF} fixed at 15%, the predicted Tm_1^{ETF} is April 2012 if the Italian ETF market follows an S-shaped trajectory. The predicted rate of diffusion is similar to that in Hungary, i.e., much lower than in, e.g., France.

Regarding Spain, with κ_1^{ETF} fixed at 5% the predicted Tm_1^{ETF} is July 2021 (considerably sooner than in the case of Hungary) and the ‘specific duration’ forecast is about 300 months. The rate of diffusion predicted is 0.015, which is consistent with the results obtained for Hungary and Italy. Finally, for France with κ_1^{ETF} fixed at 7.5%, the predicted Tm_1^{ETF} is July 2015 if the French ETF market follows the S-shaped trajectory. The rate of diffusion predicted for this level of κ_1^{ETF} is 0.028, but for higher levels it is slightly lower, which suggests that the diffusion of ETFs on the French market will be much faster than in other European countries.

The ETF diffusion paths predicted for Germany and Poland are not valid and so they will not be discussed. It should be emphasized that all these forecasts are tentative and should be treated with caution. The projected future diffusion paths are not entirely random but rather assume an S-shaped trajectory and all the predictions show a high level of sensitivity to historical data. Special caution is urged regarding the predictions referring to relatively high fixed ceilings like 20%, 25% and 30%, where the accuracy of the forecasts is questionable and they are to some extent misleading and inconclusive.

Table 4. Predicted ETFs diffusion patterns (as share of total turnover of index financial instruments). Hungary—outliers excluded. Italics = misspecifications.

κ_i^{ETF} (Upper Asymptote)—Fixed	Tm_i^{ETF} (Midpoint)—Refers to a Specific Date	Δt_i^{ETF} (Specific Duration)—Number of Months	α_i^{ETF} (Rate of Diffusion)	R ² of the Model
Poland				
5%	−229,626,799	−249,867,896	0.00	0.016
7.5%	981.7	857.4	0.005	0.018
10%	1,010.6	859.5	0.005	0.018
15%	−258,875,673	−220,949,493	0.00	0.016
20%	1,181.1	862.7	0.005	0.018
25%	1,225.8	863.3	0.005	0.018
30%	1,262.3	863.8	0.005	0.018
Hungary				
5%	282.4 (2027m6)	319.5	0.014	0.073
7.5%	318.3 (2030m6)	326.0	0.013	0.073
10%	343.2 (2032m7)	329.3	0.013	0.073
15%	377.4 (2035m5)	332.6	0.013	0.074
20%	401.2 (2037m5)	334.2	0.013	0.074
25%	419.4 (2038m11)	335.2	0.013	0.074
30%	434.2 (2040m2)	335.9	0.013	0.074
Italy				
5%		Already achieved		
7.5%		Already achieved		
10%		Already achieved		
15%	100.24 (2012m4)	246.9	0.018	0.485
20%	141.7 (2015m9)	318.7	0.014	0.454
25%	175.7 (2018m7)	359.9	0.012	0.445
30%	204.1 (2020m12)	386.9	0.011	0.435
Spain				
5%	211.4 (2021m7)	300.3	0.015	0.41
7.5%	252.4 (2024m12)	318.2	0.014	0.41
10%	280.6 (2027m4)	327.2	0.013	0.41
15%	318.9 (2030m6)	336.3	0.013	0.41
20%	345.4 (2032m9)	340.8	0.013	0.41
25%	365.6 (2034m5)	343.5	0.013	0.41
30%	381.7 (2035m9)	345.4	0.013	0.41
Germany				
5%	1,402.6	1426.9	0.003	0.02
7.5%	892.6	1349.1	0.003	0.02
10%	1003.8	1375.0	0.003	0.02
15%	1156.0	1401.0	0.003	0.02
20%	1261.3	1413.9	0.003	0.02
25%	1341.7	1421.7	0.003	0.02
30%	730.8	1297.3	0.003	0.02
France				
5%		Already achieved		
7.5%	139.9 (2015m7)	157.6	0.028	0.73
10%	156.8 (2016m12)	165.6	0.027	0.75
15%	179.7 (2018m11)	174.5	0.025	0.76
20%	195.3 (2020m3)	179.2	0.025	0.77
25%	207.2 (2021m3)	182.1	0.024	0.77
30%	216.6 (2021m12)	184.0	0.024	0.77

5. Conclusions

This extensive research was designed to analyze the development paths and dynamics of financial innovations introduced on stock exchanges in France, Germany, Spain, Italy—which have been treated as economies with relatively well developed stock exchanges—Hungary and Poland—two European economies where financial innovations have relatively short histories.

We examined the development of ETF markets using descriptive statistics and diffusion models. Graphical evidence on the ETF markets shows that ETF diffusion patterns in some countries may be described as a logistic growth trajectory—characteristic phases of the S-shaped path can be distinguished, which justifies the application of diffusion models. In Hungary and Poland, the level of ETF market development was very low and no significant changes are expected in the future unless the market environment is deeply transformed (which cannot be predicted). The trajectory of ETF market development in the more advanced European economies differed considerably. In Spain and Germany, the ETF market share remained very low and no meaningful predictions could be obtained using diffusion models. In France and Italy, significant development of ETF markets was identified and the predictions indicate potential further growth.

In our research we claimed that ETFs are financial innovations and thus it would be justifiable to analyze their development paths analogously to the process of diffusion of other tangible or intangible innovations. Following the latter, we have proposed to use the mathematical diffusion models, traditionally used to approximation of diffusion patterns of innovations, to draw the trajectories of ETFs diffusion across the financial markets. Our empirical evidence has demonstrated applicability of these diffusion models to the numerical analysis of ETFs diffusion process, allowing for detecting their in-time behavior, case-specific dynamics and development patterns, as well as providing long-term predictions. We believe that this approach to the analysis of financial markets development paves avenues for further and more profound research in this field (similar in-kind conclusions were reached in [Marszk et al. \(2019\)](#)).

Notably, ETFs as innovative financial instruments are still a poorly explored area, including our knowledge on what determines their development, or simply—what enhances or hinders their fast diffusion across financial markets. Apparently, in some countries, ETFs have rapidly gained popularity, while in other their development is negligible. The main limitation of the research method used in this study is that it is derived from the logistic growth function that is based on S-shaped trajectory of the diffusion of innovation which may be inconsistent with the attributes of the financial innovations. Moreover, our analysis has not addressed (with the exception of some preliminary suppositions) the factors that have influenced the diffusion processes. Detecting major determinants of ETFs diffusion in relation to other stock index instruments, including legal and institutional regulations that enable or stop this process, constitutes the direction of possible future research.

Author Contributions: Both authors contributed equally. Conceptualization, A.M. and E.L.; methodology, A.M. and E.L.; software, A.M. and E.L.; formal analysis, A.M. and E.L.; investigation, A.M. and E.L.; writing—original draft preparation, A.M. and E.L.; writing—review and editing, A.M. and E.L.; project administration, A.M. and E.L.; funding acquisition, A.M. and E.L. All authors have read and agreed to the published version of the manuscript.

Funding: This research was funded by project no. 2015/19/D/HS4/00399 financed by the National Science Centre, Poland. It was also supported by a grant from the CERGE-EI Foundation under a program of the Global Development Network.

Conflicts of Interest: The authors declare no conflict of interest. The funders had no role in the design of the study; in the collection, analyses, or interpretation of data; in the writing of the manuscript, or in the decision to publish the results.

Appendix A

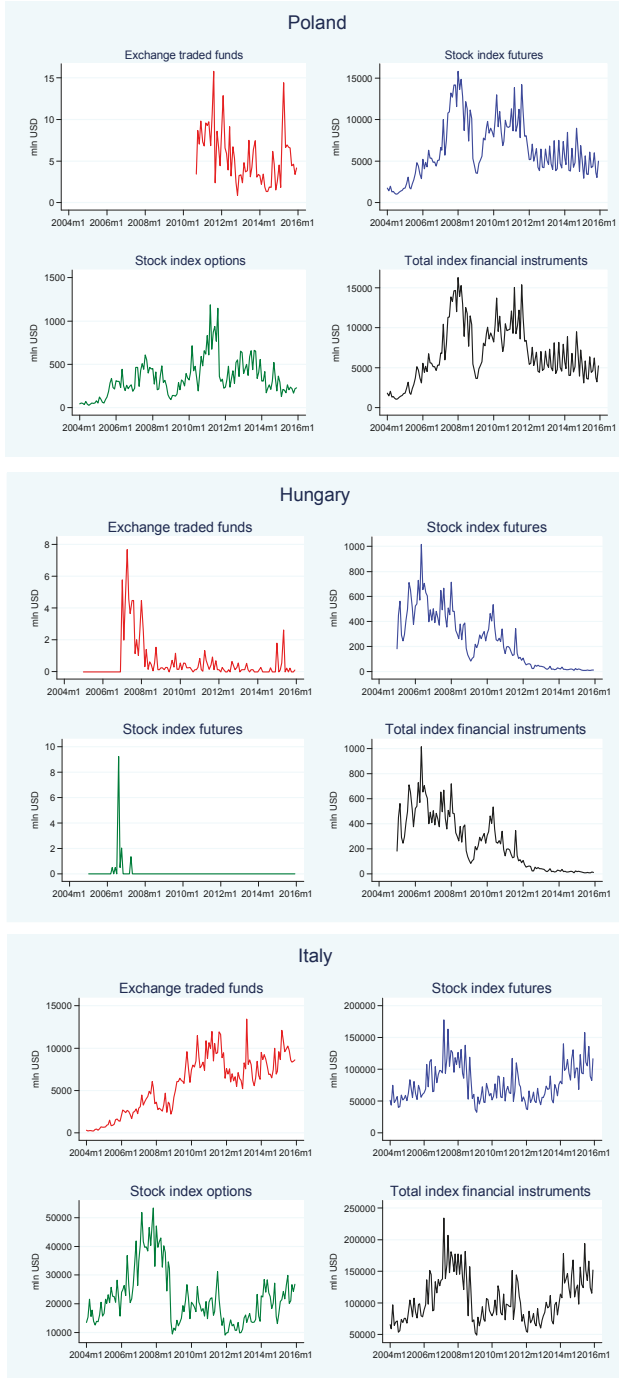

Figure A1. Cont.

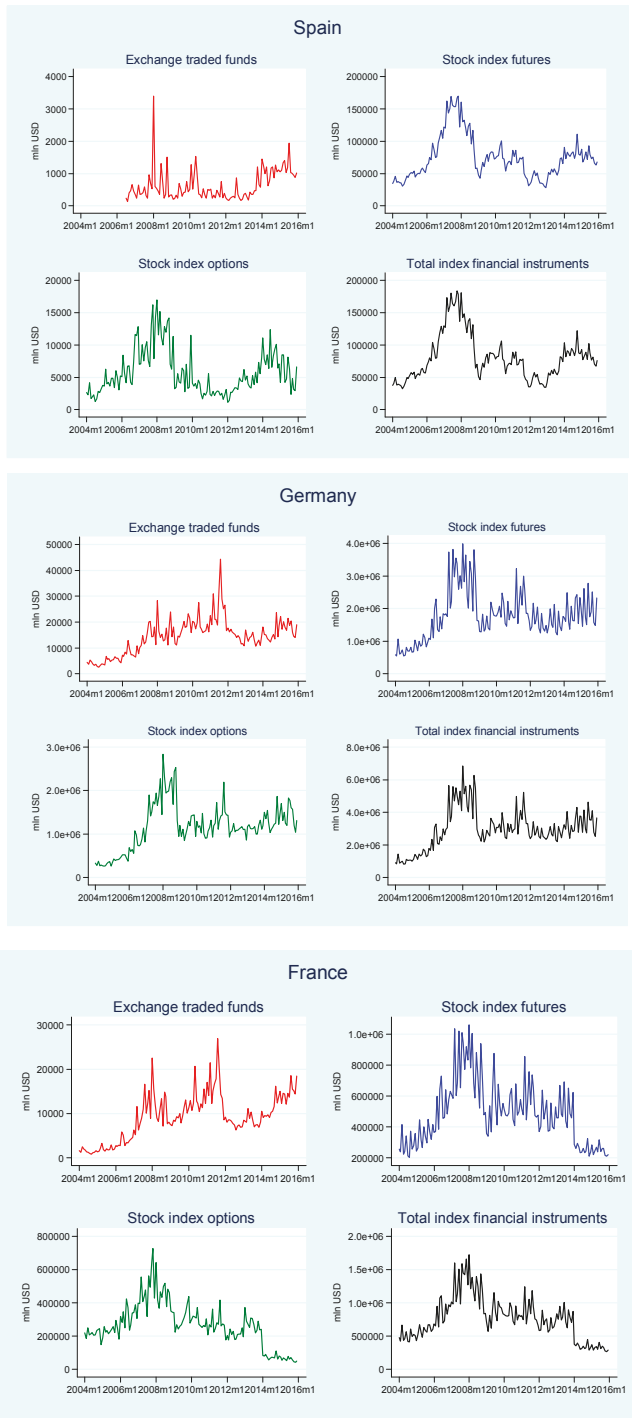

Figure A1. ETFs, stock index options, stock index futures and total index financial instruments—diffusion trajectories. 2004–2015 (monthly time series). Values in USD millions.

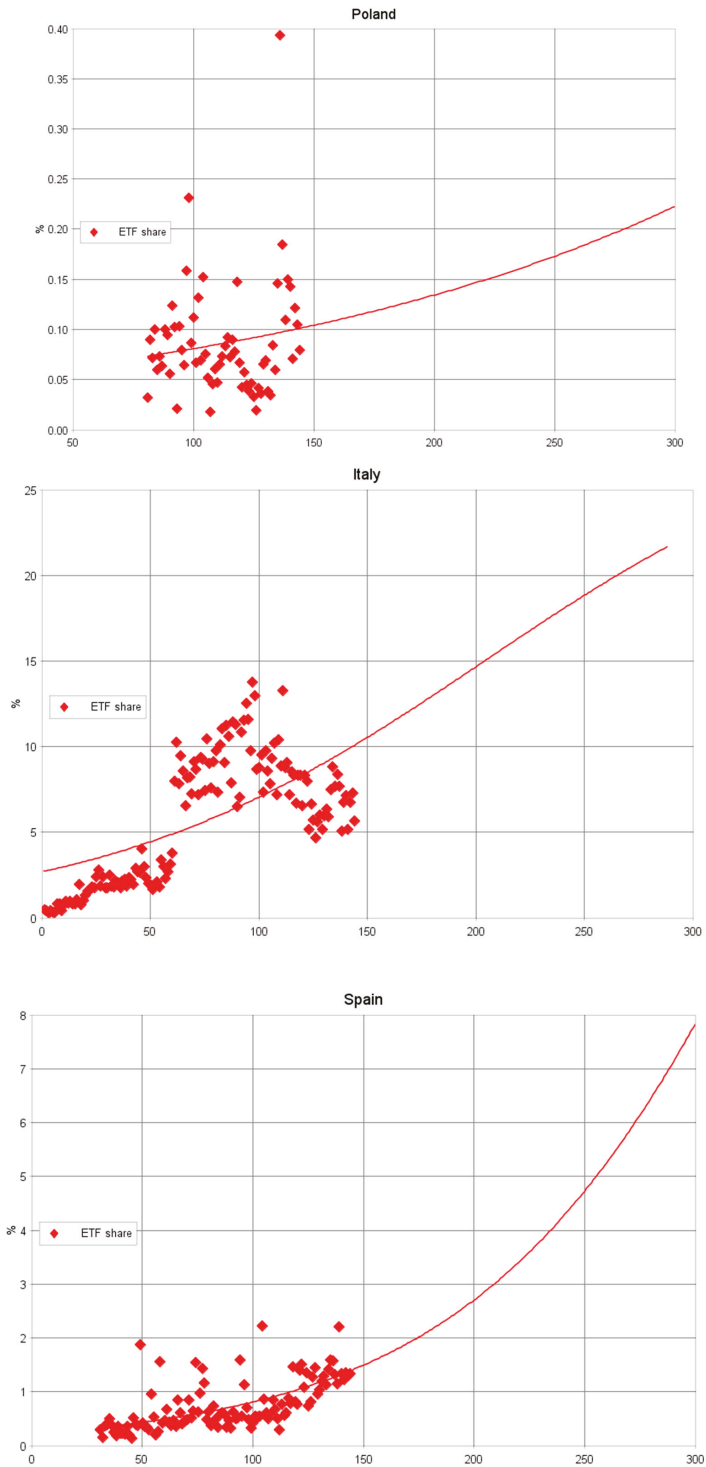

Figure A2. Cont.

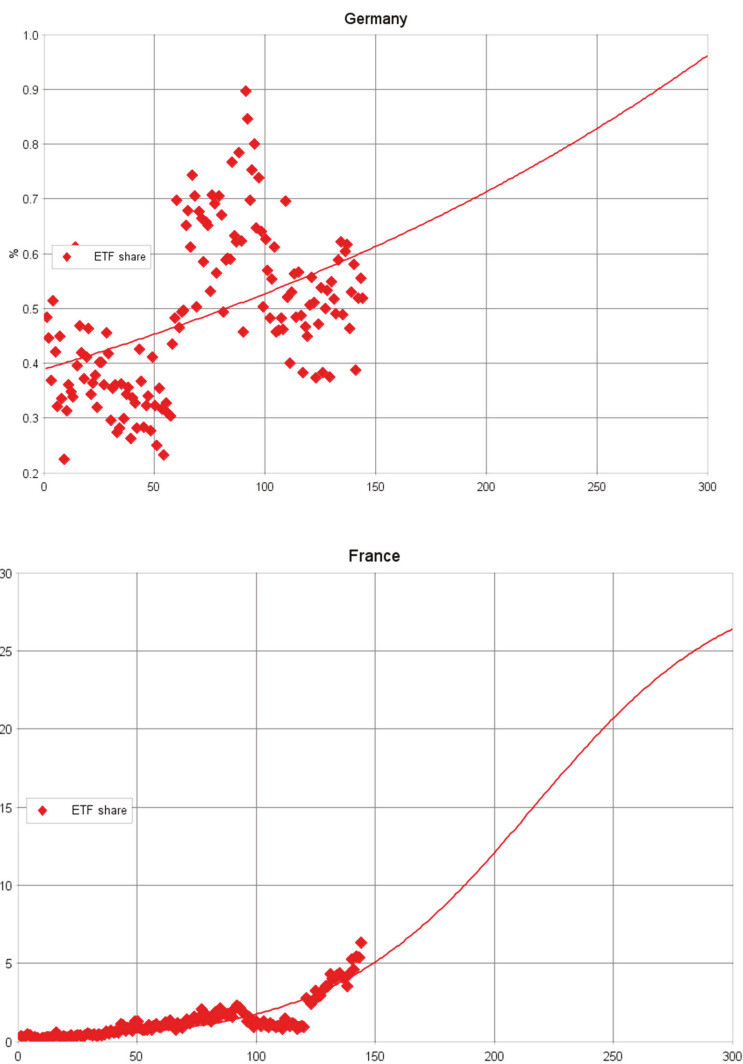

Figure A2. Current and predicted ETF diffusion patterns. Graphs and forecasts prepared using IIASA software.

References

- Abner, David. 2016. *The ETF Handbook. How to Value and Trade Exchange-Traded Funds*, 2nd ed. Hoboken: John Wiley & Sons.
- Agapova, Anna. 2011. Conventional mutual index funds versus exchange-traded funds. *Journal of Financial Markets* 14: 323–43. [[CrossRef](#)]
- Akhavein, Jalal, W. Scott Frame, and Lawrence J. White. 2005. The diffusion of financial innovation: An examination of the adoption of small business credit scoring by large banking organizations. *Journal of Business* 78: 577–96. [[CrossRef](#)]
- Alderighi, Stefano. 2020. Cross-listing in the European ETP market. *Economics Bulletin* 40: 35–40.

- Arnold, Matthew, and Antoine Lesné. 2015. *The Changing Landscape for Beta Replication—Comparing Futures and ETFs for Equity Index Exposure*. Boston: State Street Global Advisors.
- Arunanondchai, Panit, Kunlapath Sukcharoen, and David J. Leatham. 2019. Dealing with tail risk in energy commodity markets: Futures contracts versus exchange-traded funds. *Journal of Commodity Markets*. [CrossRef]
- Awrey, Dan. 2013. Toward a supply-side theory of financial innovation. *Journal of Comparative Economics* 41: 401–19. [CrossRef]
- Baltussen, Guido, Sjoerd van Bakkum, and Zhi Da. 2019. Indexing and stock market serial dependence around the world. *Journal of Financial Economics* 132: 26–48. [CrossRef]
- Ben-David, Itzhak, Francesco Franzoni, and Rabih Moussawi. 2017. Exchange Traded Funds. *Annual Review of Financial Economics* 9: 169–19. [CrossRef]
- Ben-David, Itzhak, Francesco Franzoni, and Rabih Moussawi. 2018. Do ETFs increase volatility? *The Journal of Finance* 73: 2471–535. [CrossRef]
- Blocher, Jesse, and Robert E. Whaley. 2016. Two-Sided Markets in Asset Management: Exchange-traded Funds and Securities Lending. *Vanderbilt Owen Graduate School of Management Research Paper* 2474904: 1–45. [CrossRef]
- Box, Travis, Ryan L. Davis, and Kathleen P. Fuller. 2019. ETF competition and market quality. *Financial Management* 48: 873–916. [CrossRef]
- Chang, Chia-Lin, Chia-Ping Liu, and Michael McAleer. 2019. Volatility spillovers for spot, futures, and ETF prices in agriculture and energy. *Energy Economics* 81: 779–92. [CrossRef]
- Chang, Chia-Lin, Michael McAleer, and Chien-Hsun Wang. 2018. An econometric analysis of ETF and ETF futures in financial and energy markets using generated regressors. *International Journal of Financial Studies* 6: 2. [CrossRef]
- CME Group. 2016. *The Big Picture: A Cost Comparison of Futures and ETFs*. Chicago: CME Group.
- DeMarzo, Peter, and Darrell Duffie. 1999. A liquidity-based model of security design. *Econometrica* 67: 65–99. [CrossRef]
- Diaz-Rainey, Ivan, and Gbenga Ibikunle. 2012. A Taxonomy of the ‘Dark Side’ of Financial Innovation: The Cases of High Frequency Trading and Exchange Traded Funds. *International Journal of Entrepreneurship and Innovation Management* 16: 51–72. [CrossRef]
- Dosi, Giovanni, and Richard R. Nelson. 1994. An introduction to evolutionary theories in economics. *Journal of Evolutionary Economics* 4: 153–72. [CrossRef]
- Eurex. 2016. *Futures or ETFs?—Not as Simple as Yes or No*. Eschborn: Eurex.
- Ferri, Richard A. 2009. *The ETF Book: All You Need to Know about Exchange-Traded Funds*. Hoboken: John Wiley & Sons.
- Frame, W. Scott, and Lawrence J. White. 2004. Empirical Studies of Financial Innovation: Lots of Talk, Little Action? *Journal of Economic Literature* 42: 116–44. [CrossRef]
- Frame, W. Scott, and Lawrence J. White. 2012. Technological Change, Financial Innovation, and Diffusion in Banking. In *The Oxford Handbook of Banking*. Edited by Allen N. Berger, Philip Molyneux and John O.S. Wilson. Oxford: Oxford University Press, pp. 486–507. [CrossRef]
- Gastineau, Gary L. 2010. *The Exchange-Traded Funds Manual*. Hoboken: John Wiley & Sons.
- Geroski, Paul A. 2000. Models of technology diffusion. *Research Policy* 29: 603–25. [CrossRef]
- Goltz, Felix, and David Schröder. 2011. Passive Investing before and after the Crisis: Investors’ Views on Exchange-Traded Funds and Competing Index Products. *Bankers, Markets and Investors* 110: 5–20.
- Hamid, Nizam, and Jessica Edrosolan. 2009. A comparison: Futures, swaps, and ETFs. *ETFs and Indexing* 1: 39–49.
- Hayashi, Fumiko, and Elizabeth Klee. 2003. Technology adoption and consumer payments: Evidence from survey data. *Review of Network Economics* 2: 175–90. [CrossRef]
- Hehn, Elizabeth. 2005. Introduction. In *Exchange Traded Funds: Structure, Regulation and Application of a New Fund Class*. Edited by Elizabeth Hehn. Berlin/Heidelberg: Springer, pp. 1–5. [CrossRef]
- Hill, Joanne M. 2016. The evolution and success of index strategies in ETFs. *Financial Analysts Journal* 72: 8–13. [CrossRef]
- Hill, Joanne M., and Barbara Mueller. 2001. The appeal of ETFs. *ETFs and Indexing* 1: 50–65.
- Hill, Joanne M., Dave Nadig, and Matt Hougan. 2015. *A Comprehensive Guide to Exchange-Traded Funds (ETFs)*. Charlottesville: CFA Institute Research Foundation.

- Hull, Isaiah. 2016. The development and spread of financial innovations. *Quantitative Economics* 7: 613–36. [\[CrossRef\]](#)
- Investment Company Institute. 2017. *Investment Company Fact Book 2017*. Washington, DC: Investment Company Institute.
- Jiang, Tao, Si Bao, and Long Li. 2019. The linear and nonlinear lead–lag relationship among three SSE 50 Index markets: The index futures, 50ETF spot and options markets. *Physica A: Statistical Mechanics and Its Applications* 525: 878–93. [\[CrossRef\]](#)
- Kovacova, Maria, Tomas Kliestik, Katarina Valaskova, Pavol Durana, and Zuzana Juhaszova. 2019. Systematic review of variables applied in bankruptcy prediction models of Visegrad group countries. *Oeconomia Copernicana* 10: 743–72. [\[CrossRef\]](#)
- Kucharavy, Dmitry, and Roland De Guio. 2011. Logistic substitution model and technological forecasting. *Procedia Engineering* 9: 402–16. [\[CrossRef\]](#)
- Kwasnicki, Witold. 2013. Logistic growth of the global economy and competitiveness of nations. *Technological Forecasting and Social Change* 80: 50–76. [\[CrossRef\]](#)
- Lechman, Ewa, and Adam Marszk. 2015. ICT technologies and financial innovations: The case of Exchange Traded Funds in Brazil, Japan, Mexico, South Korea and the United States. *Technological Forecasting and Social Change* 99: 355–76. [\[CrossRef\]](#)
- Lechman, Ewa. 2015. *ICT Diffusion in Developing Countries: Towards a New Concept of Technological Takeoff*. New York: Springer. [\[CrossRef\]](#)
- Lettau, Martin, and Ananth Madhavan. 2018. Exchange-Traded Funds 101 for Economists. *Journal of Economic Perspectives* 32: 135–54. [\[CrossRef\]](#)
- Liu, Pan, Dmitry Vedenov, and Gabriel J. Power. 2020. Commodity financialization and sector ETFs: Evidence from crude oil futures. *Research in International Business and Finance* 51: 101109. [\[CrossRef\]](#)
- Liu, Qingfu, and Yuman Tse. 2017. Overnight returns of stock indexes: Evidence from ETFs and futures. *International Review of Economics & Finance* 48: 440–51. [\[CrossRef\]](#)
- Madhavan, Ananth, Ursula Marchioni, Wei Li, and Daphne Yan Du. 2014. Equity ETFs versus Index Futures: A Comparison for Fully Funded Investors. *Institutional Investor Journal* 5: 66–75. [\[CrossRef\]](#)
- Madhavan, Ananth. 2016. *Exchange-Traded Funds and the New Dynamics of Investing*. Oxford: Oxford University Press. [\[CrossRef\]](#)
- Mansfield, Edwin. 1961. Technical change and the rate of imitation. *Econometrica: Journal of the Econometric Society* 29: 741–66. [\[CrossRef\]](#)
- Marszk, Adam, Ewa Lechman, and Yasuyuki Kato. 2019. *The Emergence of ETFs in Asia-Pacific*. New York: Springer. [\[CrossRef\]](#)
- McConnell, John J., and Eduardo S. Schwartz. 1992. The origin of LYONS: A case study in financial innovation. *Journal of Applied Corporate Finance* 4: 40–47. [\[CrossRef\]](#)
- Meyer, Perrin S., Jason W. Yung, and Jesse H. Ausubel. 1999. A primer on logistic growth and substitution: The mathematics of the Loglet Lab software. *Technological Forecasting and Social Change* 61: 247–71. [\[CrossRef\]](#)
- Meyer, Perrin. 1994. Bi-logistic growth. *Technological Forecasting and Social Change* 47: 89–102. [\[CrossRef\]](#)
- Molyneux, Phil, and Nidal Shamroukh. 1996. Diffusion of Financial Innovations: The Case of Junk Bonds and Note Issuance Facilities. *Journal of Money, Credit and Banking* 28: 502–22. [\[CrossRef\]](#)
- Oztekin, A. Senol, Suchismita Mishra, Pankaj K. Jain, Robert T. Daigler, Sascha Strobl, and Richard D. Holowczak. 2017. Price discovery and liquidity characteristics for US electronic futures and ETF markets. *The Journal of Trading* 12: 59–72. [\[CrossRef\]](#)
- Persons, John C., and Vincent A. Warther. 1997. Boom and bust patterns in the adoption of financial innovations. *Review of Financial Studies* 10: 939–67. [\[CrossRef\]](#)
- Philippas, Dionisis Th, and Costas Siriopoulos. 2012. Is the progress of financial innovations a continuous spiral process? *Investment Management and Financial Innovations* 9: 20–31. [\[CrossRef\]](#)
- Piccotti, Louis R. 2018. ETF Premiums and Liquidity Segmentation. *Financial Review* 53: 117–52. [\[CrossRef\]](#)
- Rogers, Everett M. 2010. *Diffusion of Innovations*, 4th ed. New York: Free Press.
- Satoh, Daisuke. 2001. A discrete bass model and its parameter estimation. *Journal of the Operations Research Society of Japan-Keiei Kagaku* 44: 1–18. [\[CrossRef\]](#)
- Srinivasan, V., and Charlotte H. Mason. 1986. Technical note—nonlinear least squares estimation of new product diffusion models. *Marketing Science* 5: 169–78. [\[CrossRef\]](#)

- Thomsett, Michael. 2016. Differences Between Stock and Future Options. InvestorGuide.com. Available online: <http://www.investorguide.com/article/12605/differences-between-stock-and-future-options-wo/> (accessed on 13 February 2020).
- Wallace, Damien, Petko S. Kalev, and Guanhua Lian. 2019. The evolution of price discovery in us equity and derivatives markets. *Journal of Futures Markets* 39: 1122–36. [CrossRef]
- Wang, Jinzhong, Hao Kang, Fei Xia, and Guowei Li. 2018. Examining the equilibrium relationship between the Shanghai 50 stock index futures and the Shanghai 50 ETF options markets. *Emerging Markets Finance and Trade* 54: 2557–76. [CrossRef]
- World Federation of Exchanges. 2017. *WFE Database*. London: World Federation of Exchanges.



© 2020 by the authors. Licensee MDPI, Basel, Switzerland. This article is an open access article distributed under the terms and conditions of the Creative Commons Attribution (CC BY) license (<http://creativecommons.org/licenses/by/4.0/>).

Article

Heads and Tails of Earnings Management: Quantitative Analysis in Emerging Countries

Pavol Durana ^{1,*}, Katarina Valaskova ¹, Darina Chlebkova ¹, Vladislav Krastev ² and Irina Atanasova ²

¹ Faculty of Operation and Economics of Transport and Communications, Department of Economics, University of Zilina, 010 26 Zilina, Slovakia; katarina.valaskova@fpedas.uniza.sk (K.V.); darina.chlebkova@fpedas.uniza.sk (D.C.)

² Department of Economics, South-West University, 2746 Blagoevgrad, Bulgaria; vladislav_swu@law.swu.bg (V.K.); irina_atanasova@yahoo.com (I.A.)

* Correspondence: pavol.durana@fpedas.uniza.sk; Tel.: +421-41-513-3217

Received: 29 April 2020; Accepted: 27 May 2020; Published: 1 June 2020

Abstract: Earnings management is a globally used tool for long-term profitable enterprises and for the apparatus of reduction of bankruptcy risk in developed countries. This phenomenon belongs to the integral and fundamental part of their business finance. However, this has still been lax in emerging countries. The models of detections of the existence of earnings management are based on discretionary accrual. The goal of this article is to detect the existence of earnings management in emerging countries by times series analysis. This econometric investigation uses the observations of earnings before interest and taxes of 1089 Slovak enterprises and 1421 Bulgarian enterprises in financial modelling. Our findings confirm the significant existence of earnings management in both analyzed countries, based on a quantitative analysis of unit root and stationarity. The managerial activities are purposeful, which is proven by the existence of no stationarity in the time series and a clear occurrence of the unit root. In addition, the results highlight the year 2014 as a significant milestone of change in the development of earnings management in both countries, based on homogeneity analyses. These facts identify significant parallels between Slovak and Bulgarian economics and business finance.

Keywords: business finance; earnings management; EBIT; financial modelling; homogeneity; stationarity; time series methods; unit root

1. Introduction

The issues of risk management have been analyzed and discussed for a long time (Hudakova et al. 2018). The managements of the enterprises must select the best solutions for future development in any conditions (Kral et al. 2019). Spuchlakova and Cug (2015) argue that a structural approach is necessary to reduce and model their business risk. Meyers et al. (2019) highlight big data-driven algorithmic decision-making related to risk management. Vagner (2017) adds that the practical benefits connected with cost controlling and costs optimization and earnings management may be very beneficial for applying to enterprises to risk. Earnings management is an accounting technique to manage financial reports that shows a mostly positive view of business finance and the financial situation. Earnings management means the transformation into a new accounting regime, in a lot of cases (Hoang and Joseph 2019). The reasons for managers to do a manipulation of earnings is good looking for investors and potential investors (Susanto et al. 2019), moreover, Khanh and Thu (2019) declare a positive correlation between earnings management and leverage management. This phenomenon of earnings modification is an increasingly important topic, obviously in the area of the assessment of efficiency—which is a fundamental part of the corporate rational behavior that aims to survive in a challenging competitive

environment in the long term (Balcerzak et al. 2017)—as well as in the areas of financial accounting, financial risk and financial modelling. The most relevant researches have been conducted in the developed markets, but this topic is very rarely investigated in emerging countries, as they still adhere to conventional approaches. The European market significantly varies from other global markets (Rahman et al. 2017).

The number of publications concerned with earnings management changes according to the country. From all the countries, earnings management is the most discussed topic in the USA. Almost five thousand research papers have their origins in this country. We may highlight that developed European countries, such as the United Kingdom (Iatridis and Kadorinis 2009; Pina et al. 2012), Spain (Ferrer Garcia and Lainez Gadea 2013; Rodriguez-Perez and van Hemmen 2010), Germany (Christensen et al. 2015; Velte 2019), Italy (Cimini 2015), the Netherlands (Kempen 2010), Belgium (Andries et al. 2017), France (Bzeouich et al. 2019; Ben Amar and Chakroun 2018) and many others, focus on earnings management phenomenon from different perspectives. However, the issue of earnings management is not developed and investigated properly in emerging countries, with various explanations for this. The identified research gap was analyzed in the case of Slovakia (SK) and Bulgaria (BG). Both countries, former Soviet-controlled Eastern bloc countries, have experienced a massive transformation of their economies over the past decades, and their significant development has been emphasized by their participation in the European Union. Following their economic development (Figure 1) using the gross domestic product (GDP) index, it is evident that the same development trend in the 10-year horizon can be indicated.

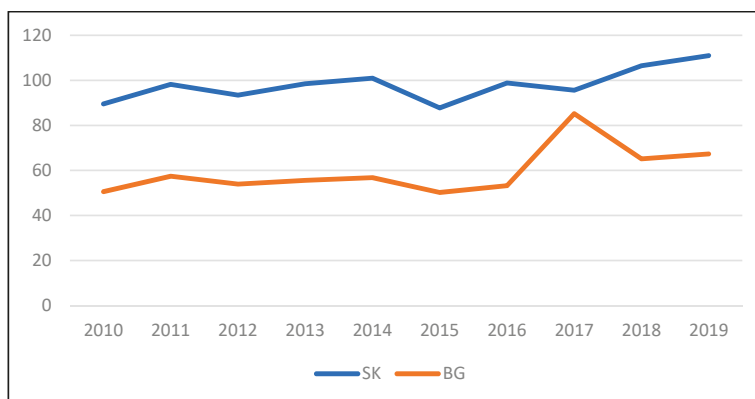

Figure 1. Gross domestic product (GDP) index. Source: Trading Economics.

Moreover, both countries established mutual cooperation in several areas, one of them is focused on the support of local communities and society by the establishment of the Environmental Partnership Association (EPA) Consortium; they expand the bilateral cooperation in the high-tech sector. The development of mutual cooperation in different sectors of economy forced authors to aim the research at these two countries. Slovakia is the largest producer of cars per capita, with highly developed automobile and electronics exports accounting for more than 80 per cent of national gross domestic product. However, Bulgaria changes its sectoral orientation from agricultural to an industrial economy, which makes the situation in the countries easier to compare. Despite the fact that, according to the rating of the World Bank Country and Lending Groups, Bulgaria is an open upper-middle-income market economy, contrary to Slovakia, which is an open high-income market economy, the importance of the research on the earnings management phenomenon is of a vital importance in both countries. The detection and revelation of manipulation with earnings needs to be portrayed, as it is a relevant measure of investors' and business partners' protection against risks which may occur if distorted and

incomplete information is presented by the enterprises; thus, it is a helpful tool to solve the basic issues of risk management.

It is evident that the earnings management phenomenon plays an important role in financial reports managing and should be properly investigated in conditions of national economies. However, the fact is that this issue has not been explored properly in both countries analyzed. In Slovakia, the first researches on earnings management were published in 2019, highlighting the importance of this issue in unique country samples. Nonetheless, no relevant research has been published yet on the conditions of Bulgaria. Thus, this study investigates earnings management in both countries and determines its presence by quantitative methods of time series.

The main aim and the essence of the study is to investigate the question of earnings management in Bulgarian and Slovak environments, where the motivation is to detect the existence of earnings management by time series analysis, as this topic is only rarely searched for in emerging countries. The investigation of the presence of manipulation with earnings may help to reveal the reasons for earnings management occurrence. As the issue of manipulation with earnings in both countries is unexplored, the significance of the analysis of unique country samples has to be underlined.

The manuscript is structured as follows. In the introduction, the purpose of the study and the significance of the issue of earnings management are provided. Then, the literature review is presented, concentrating on the analyses of different approaches and investigations of the solved topic. The next chapter depicts the materials used and appropriate methods of mathematical statistics to fulfil the aim. These quantitative methods are: the Dixon test, Jarque–Bera test, Box–Pierce test, Dickey–Fuller tests, Kwiatkowski–Phillips–Schmidt–Shin test, Von Neumann’s test, and Standard Normal Homogeneity test. The outcomes of the investigation, as well as the results of the hypotheses, are portrayed in the Results section. This part confirms the existence of the earnings management of Slovak and Bulgarian enterprises and marks the year 2014 as a significant milestone in the development of earnings management in both countries. In the Discussion section, the connection of ease of doing business, annual growth rate of gross domestic product (GDP), long-term unemployment rank and Standard & Poor’s outlook to the results is implicated and previous studies from emerging markets are compared. The limitations and weaknesses of our study are noted, and possible avenues of future research are determined in the conclusions of the research.

1.1. Literature Review

1.1.1. Graphic Modelling of Specific Accruals

The first mention of earnings management is captured in a study of [Hepworth \(1953\)](#), which was focused on balancing periodic income. The author captured several tactics, e.g., methods of balancing income through specific accruals that can be used to move net profit to subsequent accounting periods. [Hepworth \(1953\)](#) did not capture a way to identify the transfer of profits itself.

The initial disclosure of corporate earnings management is based on graphical methods based on data set in the time series. [Gordon \(1964\)](#) examines whether managers choose accounting principles and reporting rules that allow them to balance reported earnings. For each of the enterprises examined, he establishes a curve showing the profit calculated in two ways—excluding and including the dependent variables. If the discrepancies in the observations are smaller in the latter case, the earnings adjustment is due to movements in the account. [Dopuch and Drake \(1966\)](#) create a group of enterprises. For each enterprise, they record the total income and income from the given investment shares. The authors argue that adjusting the earnings with this approach does not pose a serious problem for the enterprise in the group, a certain part of the observed enterprise apparently acts purposefully. [Archibald \(1967\)](#) investigates how and why the set of enterprises has shifted from accelerated depreciation of fixed assets to straight-line depreciation for financial and tax reasons.

1.1.2. Mathematical Modelling of Specific Accruals

Gordon et al. (1966) use mathematical modelling to test the profit equalization. The authors choose the investment credit as a variable to test whether enterprises are trying to balance profits. Copeland (1968) empirically tests the use of more than one variable in revealing the existence of earnings management through additional scrutiny of government financial statements. White (1970) applies other tests, using profits from a decade. He includes several dependent variables in the tests and, for the first time, uses regression as a method to detect enterprises that balance earnings. Dascher and Malcom (1970) perform a test applying data from a six- and eleven-year time interval and draw conclusions about the reduction in semi-logarithmic trend variability attributable to discretionary balance variables. Barefield and Comiskey (1972) use data from a ten-year time series to identify variability and average absolute profit increase in enterprises that may use earnings from non-consolidated subsidiaries to balance.

1.1.3. Modelling of Total Discretionary Accruals with Application of Cross-Sectional Data

Burgstahler and Dichev (1997) detect earnings management on a cross-sectional analysis. In their research, they verify whether the managers of the tested enterprises are trying to avoid a decline in profits or losses. They choose binomial tests to verify the hypotheses in their research and present the results graphically using histograms. Degeorge et al. (1999) focus on exceeding threshold values. The authors conclude that thresholds artificially evoke specific forms of earnings management, with positive thresholds being the most dominant.

1.1.4. Modelling Using Manipulation Score

Beneish (1997) proposes a model detecting earnings manipulation similar to the Altman's bankruptcy model. Variables called M-score capture both the distortion of financial statements and the factors that can stimulate enterprises to manipulate. Beneish (1997) and Young (1999) independently express doubts about the involvement of depreciation in the measurement of total accruals.

1.1.5. Cross-Sectional Earnings Analysis and Accrual Modelling

Peasnell et al. (2000) provide a new approach for approximation of abnormal accruals, labelled as the Margin model, which applied cross-sectional data to mitigate the weaknesses of the Jones model (Jones 1991). The authors take a two-step approach from previous models but use the working capital accrual and different explanatory variables—sales and cash from customers—as an estimate of the total accrual. The authors are criticized for assuming a linear relationship between cash flow and accruals.

1.1.6. Detection of Real Earnings Management

Burgstahler and Dichev (1997) find that enterprises often use cash flow gained by operating activities and working capital to earnings management. Headquarters pursuing specific goals thus change their economic performance and their decisions in order to make a profit. Dechow and Skinner (2000) point out that head officers can modify earnings by shifting revenue differentiation, changing the timing of deliveries, or postponing research and development to keep costs at the desired level. Graham et al. (2005) note that the most commonly used earnings management method is the modification of discretionary accruals thanks to its simplicity, inexpensiveness and difficulty to identify by recipients of financial statements. Roychowdhury (2006) finds that many enterprises stop earnings management through discretionary accruals. The author proves that the modification of discretionary accruals is no more the core way of earnings management. Penman and Zhang (2002) argue that enterprises increase earnings by reducing capital investment. Gunny (2010) states that real earnings management involves changes in the underlying operations and activities of the enterprises to increase earnings in the current period. Eldenburg et al. (2011) run their study in the environment of non-profit organizations, proving the existence of real operational decisions in order to manage earnings.

1.1.7. Modelling Using Neural Networks

Hoglund (2012), because of the insufficient results of previous approaches, applies an alternative way to deal with the nonlinearity of accrual processes through neural networks. He designs models based on self-organizing maps, multilayer networks and general regression.

1.1.8. Modelling of Total Discretionary Accruals with Application of Time Series

Healy (1985) applies average total accruals as an estimate of discretionary accruals, and thus an estimate of earnings management. Healy's model clearly assumes the non-existence of non-discretionary accruals during estimation periods. The author concludes that the accrual policy of managers is related to incentive bonuses, which are enshrined in their contracts, and thus the shift in accounting practices is related to changes of the extra payment schedule. Kaplan (1985) criticized Healy (1985). DeAngelo (1986) supplemented Healy's model with an accrual from the previous period. The model does not assume the existence of non-discretionary accruals in the present interval and uses the non-discretionary accruals from the previous period to estimate them. McNichols and Wilson (1988) add to the DeAngelo model capturing discretionary accruals as measures of earnings management, replacing the total accruals applied by Healy (1985) and DeAngelo (1986).

Jones (1991) investigates earnings management using two-step models during a government investigation of import relief in the United States. It is used an enterprise-specific model, based on data from at least fourteen-year time series. Discretionary accrual, which represents the remainder, prediction error, calculated as the difference among the current total accruals found in the financial statements and the expected non-discretionary accruals. Dechow et al. (1995) modified the original Jones model by supplementing the year-on-year change in receivables, thus eliminating the error of the discretionary accrual estimate. Guay et al. (1996) criticize both the original and the modified Jones model but does not suggest any other alternatives.

Our study also continues in approaches of detecting of earnings management with application of time series. We consider the new gap to disclose the earnings manipulation of the enterprises through unit root and stationarity analysis, supported by homogeneity analyses. The time series analysis allows us to formulate the following hypotheses:

- **H_A**. *There is a unit root for the series of EBIT. There is a significant existence of the earnings management.*
- **H_B**. *The series of EBIT is not stationary. There is a significant existence of the earnings management.*
- **H_C**. *The series of EBIT is heterogeneous. There is a significant change in the earnings management.*
- **H_D**. *The series of EBIT is heterogeneous. There is a year of a significant change in the earnings management.*

2. Materials and Methods

The secondary sources are observations of earnings before interest and taxes (EBIT) of the enterprises from the chosen emerging countries (Slovakia and Bulgaria). In the context of historical development, we may add Slovakia to the Soviet-controlled Eastern bloc countries and Bulgaria to the Soviet-controlled Balkans countries. In total, 1347 Slovak enterprises and 1839 Bulgarian enterprises were extracted from the Amadeus database over the period 2010 to 2018 and involved in the analysis. The variable earnings before interests and taxes (EBIT) is selected to eliminate different tax and interest policies of these countries. We require three conditions to be met by the analyzed business units:

- (a) The amount of total assets is at least EUR 3,000,000;
- (b) The amount of total sales is at least EUR 2,000,000;
- (c) The amount of net income is minimally EUR 100,000.

These criteria were used to analyze only the companies with stable financial situation and the same financial and economic background to mitigate the problems of the classification of enterprises by their size or the years of their operation.

Following methodological steps were used:

1. The elimination of missing cases.

The database Amadeus provides a large sample of data, but there are some missing cases involved. If we have a sufficiently large data file, we may afford a simple solution in the form of removing those units from the file that have missing values (Svabova and Michalkova 2018). Thus, these observations are necessary to be found and eliminated.

2. The removal of inconsistent cases.

An outlier in a sample is an observation far away from most or all other observations (Ghosh and Vogt 2012). Different methods and tests are used to determine the existence of outliers in raw samples. Svabova and Michalkova (2018) recommend in pre-processing of data in earnings management to use Dixon or Grubbs test. Both tests provide satisfying results in identification of the outlying values (Garcia 2012). “Masking phenomenon” (several observations are close together, but the group of observations is still outlying from the rest of data (Berti-Équille et al. 2015) could occur in our case that is why the Dixon statistics r_{22} is chosen. This test is designed to be used in situations where additional outliers may occur to minimize the effect of these outliers arise because of masking (Garcia 2012). An avoiding of additional outliers allows using conventional Dickey–Fuller tests in further analysis and prevents the spurious rejection of H_0 of these tests (Leybourne et al. 1998). The test statistic of Dixon is defined as:

$$r_{22} = \frac{y_3 - y_1}{y_{n-2} - y_1} \text{ or } r_{22} = \frac{y_n - y_{n-2}}{y_n - y_3} \tag{1}$$

where y is an analyzed variable and numbers mean the places in the order.

Nagy (2016) highlights the possibilities after the detection of outliers: do not consider/ignore outliers, exclude outliers or exclude only extreme values (far outliers). We decide to apply the possibility of removal of all inconsistent cases to robust statistics and results insensitive to the outliers which is also supported by the study of Svabova and Durica (2019). They argue that it may be useful to eliminate outlined enterprises from the analyzed group because of the fact that outliers may generate discrepancies of conclusions of statistical tests and procedures. We run test and its p -values are estimated with a Monte Carlo simulation using 1,000,000 replicates.

3. The verification of normal distribution.

Normally distributed sample is a required assumption in the estimation of attributes of the times series (Bai and Ng 2005). There are nearly 40 tests of normality in the statistical literature (Dufour Jean-Marie et al. 1998). Bai and Ng (2005) recommend testing the normality of time series of financial data by the Jarque–Bera test. Jarque and Bera (1980) and Bera and Jarque (1981) show their test statistics as follows:

$$JB = \frac{n}{6} \left(S^2 + \frac{1}{4}(K - 3)^2 \right) \tag{2}$$

$$S = Skewness = \frac{\hat{\mu}_3}{\hat{\sigma}_3} = \frac{\frac{1}{n} \sum_{i=1}^n (y_i - \bar{y})^3}{\left(\frac{1}{n} \sum_{i=1}^n (y_i - \bar{y})^2 \right)^{\frac{3}{2}}} \tag{3}$$

$$K = Kurtosis = \frac{\hat{\mu}_4}{\hat{\sigma}_4} = \frac{\frac{1}{n} \sum_{i=1}^n (y_i - \bar{y})^4}{\left(\frac{1}{n} \sum_{i=1}^n (y_i - \bar{y})^2 \right)^2} \tag{4}$$

where y is an analyzed variable, n means all amount of observations, $\hat{\mu}_3$ and $\hat{\mu}_4$ mean the approximations of third and fourth central moments, \bar{y} means the average of the sample, $\hat{\sigma}_2$ is the approximation of the second central moment, the variance. Jarque–Bera is asymptotically χ^2 distributed with two degrees of freedom because test statistics of Jarque–Bera test is just the sum of squares of two asymptotically independent standardized normals (Bowman and Shenton 1975).

4. The proof of no serial correlation.

The occurrence of no serial correlation means that the data are independently distributed, and it is a recommended assumption for financial time series after testing normality. The Box–Pierce and Ljung–Box tests are generally run to test the required independence in time series. Box and Pierce (1970) perform the test of the randomness at each distinct lag in their study. Ljung and Box (1978) modify this test to overall randomness. We prefer the robustness of the Box–Pierce Q statistic to test if the analyzed sample of financial data is uncorrelated without assuming statistical independence.

$$Q = n \sum_{k=1}^h r_k^2 \tag{5}$$

Q is the Box–Pierce test statistic, which is compared with the χ^2 distribution; n means all amount of observations; h is the maximum lag we are considering (Box and Pierce 1970).

5. The determination of unit root and disproof of stationarity.

A time series is stationary if its statistical properties do not change in the process of time. A stationary time series means that the mean and variance are constant over time. The white noise is an example of a stationary time series. The determination that a series is not stationary enables to study where the non-stationarity comes from. Stationarity tests may determine whether a series is stationary or not. There are different approaches on how to test stationarity (unit root or stationarity tests). Unit root tests, as the Dickey–Fuller test and its augmented version, for which H_0 is that the series possesses a unit root and thus is not stationary. On the other hand, there are stationarity tests as the parametric Kwiatkowski–Phillips–Schmidt–Shin test or nonparametric Phillips–Perron test, for which H_0 is that the series is stationary. Standard Dickey–Fuller tests can have very low power and can lead to a very serious problem of spurious rejection of the unit root H_0 (Leybourne et al. 1998) and thus we support the tests by Kwiatkowski–Phillips–Schmidt–Shin test. Dickey and Fuller (1979) show three different equations to test the occurrence of unit root:

$$\Delta y_t = \gamma y_{t-1} + \varepsilon_t \tag{6}$$

$$\Delta y_t = a_0 + \gamma y_{t-1} + \varepsilon_t \tag{7}$$

$$\Delta y_t = a_0 + \gamma y_{t-1} + a_2 t + \varepsilon_t \tag{8}$$

where Δy_t is first order linear differential of equation, γ is unit root, ε_t is white noise. The difference between these deterministic elements is a_0 and $a_2 t$. Under the null hypothesis, Equation (6) represents a pure model of random walk, Equation (7) adds the intercept a_0 , and Equation (8) contains both the a_0 as well as linear time trend $a_2 t$. Hacker and Hatemi-J (2010) argue that it is difficult to choose from the three Dickey–Fuller equations for unit root testing. According to Elder and Kennedy (2001), if the trend is mistakenly included, the strength of the test drops. On the contrary, if the trend is not included, there is only one way to capture the trend—to use the intercept to detect the trend. All three tests are computed to compare their results and strength in our analysis.

The Kwiatkowski–Phillips–Schmidt–Shin test verifies if a time series is stationary around a mean or linear trend or is non-stationary due to a unit root (Kwiatkowski et al. 1992). Time series is divided into the sum of the random walk r_t , deterministic trend ξt , and stationary errors ε_t :

$$y_t = r_t + \xi t + \varepsilon_t \tag{9}$$

where r_t is random walk:

$$r_t = r_{t-1} + u_t \tag{10}$$

where u_t are independent and identically distributed random variables $(0, \sigma_u^2)$.

It is used ω statistics for testing:

$$\omega = \frac{\sum_{t=1}^T S_t^2}{T^2 \hat{\sigma}_\varepsilon^2} \tag{11}$$

where

$$S_t = \sum_{i=1}^t e_i \tag{12}$$

and $\hat{\sigma}_\varepsilon^2$ is the estimate of long-term variance e_t :

$$\hat{\sigma}_\varepsilon^2 = \lim_{T \rightarrow \infty} \frac{E}{T} \left[\left(\sum_{t=1}^T \varepsilon_t \right)^2 \right] \tag{13}$$

6. The determination of heterogeneity.

Homogeneity tests allow detecting if time series may be considered as homogeneous during the analyzed time period, or if there is any date at which significant change in a mean of data occurred. Kanovsky (2018) and Agha et al. (2017) recommend selecting from von Neumann test, standard normal homogeneity test, Buishand tests, and Pettitt’s test. We apply the von Neumann test to detect the existence of significant changepoint in the earnings management and parametric standard normal homogeneity test to determine a year when a significant change occurs. Von Neumann’s test is a test using the ratio of mean square successive (year to year) difference to the variance (Von Neumann 1941). The test statistic is shown as follows:

$$N = \frac{\sum_{i=1}^{n-1} (y_i - y_{i+1})^2}{\sum_{i=1}^{n-1} (y_i - \bar{y})^2} \tag{14}$$

The null hypothesis is that the data are dependent. If the value of N is equal to 2, it means that the sample is homogeneous while the values of N less than 2 indicate that the sample has a breakpoint (Buishand 1982). This test gives no information about the break point.

The standard normal homogeneity test is a method created by Alexandersson (1986) and assumes if a times series is normally distributed (Kang and Yusof 2012). Then the following model with a single change can be proposed according to Pohlert (2016) as:

$$y_i = \begin{cases} \mu + \varepsilon_i & i = 1, \dots, m \\ \mu + \Delta + \varepsilon_i & i = m + 1, \dots, n \end{cases} \tag{15}$$

$\varepsilon \approx N(0, \sigma)$. The null hypothesis $\Delta = 0$ is tested against the alternative hypothesis $\Delta \neq 0$. The test statistic is:

$$T_k = kz_1^2 + (n - k) z_2^2 \quad (1 \leq k \leq n) \tag{16}$$

where

$$z_1 = \frac{1}{k} \sum_{i=1}^k \frac{y_i - \bar{y}}{\sigma} \quad z_2 = \frac{1}{n - k} \sum_{i=k+1}^n \frac{y_i - \bar{y}}{\sigma} \tag{17}$$

The critical value is:

$$T_0 = \max_{1 \leq k \leq n} T_k \tag{18}$$

The p -value is estimated by a Monte Carlo simulation using m replicates. We run test and its p -values are estimated with a Monte Carlo simulation using 1,000,000 replicates.

3. Results

This part consists of pre-processing data, testing of assumptions and processing results.

3.1. Pre-Processing of Data

The samples were very wide but consisted of significant amount of missing values. These values of EBIT were found and eliminated from the Slovak sample of enterprises as well as the Bulgarian one. Table 1 involves the number of missing values.

Table 1. Investigate samples.

Samples	Slovakia	Bulgaria
Origin	1347	1839
Missing values	189	358
Outliers	69	60
Final	1089	1421

Source: own research.

The detection of inconsistent data (outliers) follows the identification of missing values. Dixon test is used in the analysis. Testing is run for every observation for each year from the analyzed nine-year period. The outlying cases are detected for every year. The enterprise is removed from the analysis for all periods if only one value is detected as an outlier. The Dixon test is created for small sample despite this fact we use it for its robustness. The p -value was computed using 1,000,000 Monte Carlo simulations. The existence of minimal one outlying value of EBIT for Slovak and Bulgarian samples in every analyzed year is confirmed based on p -value computed in Table 2, which portrays the amount of outlying cases of enterprises for both sides and the final sample as well.

Table 2. Dixon test.

Year	Observed Value		Critical Value		p -Value (Two-Tailed)		Alpha
	Slovakia	Bulgaria	Slovakia	Bulgaria	Slovakia	Bulgaria	
2010	0.621	0.447	0.174	0.168	<0.0001	<0.0001	0.05
2011	0.272	0.597	0.174	0.168	<0.0001	<0.0001	0.05
2012	0.491	0.205	0.174	0.168	<0.0001	<0.012	0.05
2013	0.273	0.411	0.174	0.168	<0.0001	<0.0001	0.05
2014	0.715	0.290	0.174	0.168	<0.0001	0.0002	0.05
2015	0.611	0.434	0.174	0.168	<0.0001	<0.0001	0.05
2016	0.639	0.241	0.174	0.168	<0.0001	<0.003	0.05
2017	0.809	0.540	0.174	0.168	<0.0001	<0.0001	0.05
2018	0.668	0.248	0.174	0.168	<0.0001	0.002	0.05

Source: own research.

Based on annual values of EBIT of 1089 Slovak enterprises and 1421 Bulgarian enterprises, annual average EBIT is calculated for the analyzed period from 2010 to 2019 (Table 3). The development of both countries in time is very similar, which is shown in Figure 2. The similarities of the development of EBIT is also supported by 5% error bars (calculated based on standard deviation) which show almost identical coverage of EBIT development in seven years from the nine-year analyzed period.

Table 3. Annual average EBIT of enterprises.

Year	Slovakia [Thousand €]	Bulgaria [Thousand €]
2010	826.304	809.544
2011	849.407	903.255
2012	832.338	987.599
2013	891.055	1042.889
2014	1074.256	1189.924
2015	1247.988	1391.023
2016	1359.095	1437.167
2017	1438.782	1543.163
2018	1444.950	1561.801

Source: own research.

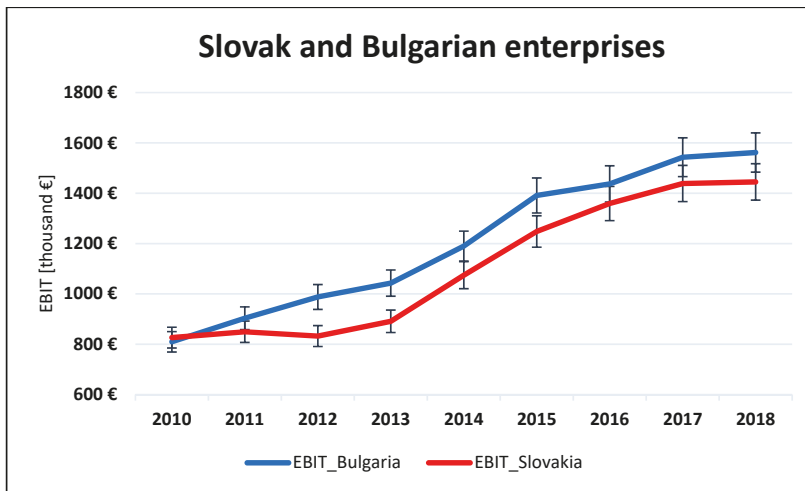

Figure 2. The values of average EBIT with error bars. Source: own research.

3.2. Testing of Assumptions

It is necessary to prove the assumption concerned with the normality (Jarque–Bera test) on the one hand and on the other hand to prove the assumption of serial correlation (Box–Pierce test). These tests are run for the series of EBIT of enterprises before testing any significant occurrence of earnings management or occurrence of the significant year of the change in the earnings management in Slovak or Bulgarian enterprises.

As the computed p -value is greater than the significance level α , one cannot reject the null hypothesis H_0 in Slovak case as well as in Bulgarian case, based on Table 4. It is not rejected based on Jarque–Bera test that the sample of EBIT of extracted Slovak and Bulgarian enterprises follows a normal distribution. The test of the randomness of the sampling process is running after proving the normality.

Table 4. Jarque–Bera test.

Jarque–Bera Test	Slovakia	Bulgaria
JB (Observed value)	1.119	0.884
JB (Critical value)	5.991	5.991
DF	2	2
<i>p</i> -value (Two-tailed)	0.572	0.643
alpha	0.05	0.05

Source: own research.

As the computed *p*-value is greater than the significance level alpha, one cannot reject the null hypothesis H_0 , based on Table 5. It is not rejected based on Box–Pierce test that the data of EBIT of Slovak enterprises, as well as Bulgarian enterprises, exhibit no serial correlation.

Table 5. Box–Pierce test.

Box–Pierce Test	Slovakia	Bulgaria
DF	6	6
Q	11.172	9.630
<i>p</i> -value (Two-tailed)	0.083	0.141
alpha	0.05	0.05

Source: own research.

3.3. Processing of Results

After proving normality and confirmation of no serial correlation significant, the occurrence of earnings management and significant year of the change in the earnings management in Slovak or Bulgarian enterprises are testing. These investigations are realized by stationarity tests and homogeneity tests.

Firstly, Dickey–Fuller test of unit root for No intercept, Intercept, and lastly Intercept + Trend is used. Null hypothesis indicates that the series possesses a unit root and hence it is not stationary. It means, statistical properties of EBIT of Slovak and Bulgarian enterprises vary with time. The earnings management exists, the managerial activities are not random, but the managers of the enterprises purposefully manipulate earnings within the legal barriers.

- **H_{1A}**. *There is no unit root for the series of EBIT. There is no significant existence of the earnings management.*

As the computed *p*-value is greater than the significance level alpha, one cannot reject the null hypothesis H_{0A} , based on Table 6. It is not rejected following the Dickey–Fuller test of unit root for No intercept, Intercept, and Intercept + Trend, that there is a unit root for the series of EBIT. There is significant existence of the earnings management of Slovak and Bulgarian enterprises.

Table 6. Dickey–Fuller test.

Dickey–Fuller Test	Observed Value		Critical Value		<i>p</i> -Value (One-Tailed)		Alpha
	Slovakia	Bulgaria	Slovakia	Bulgaria	Slovakia	Bulgaria	
No intercept	2.788	3.724	−1.965	−1.965	0.993	0.998	0.05
Intercept	0.007	−0.699	−3.353	−3.353	0.932	0.792	0.05
Intercept + Trend	−1.843	−1.620	−4.230	−4.230	0.588	0.688	0.05

Source: own research.

Secondly, the result of the Dickey–Fuller test of unit root is recommended to be supported by the Kwiatkowski–Phillips–Schmidt–Shin test of stationarity for Level and Trend. The null hypothesis is, on the contrary to Dickey–Fuller test, that the verification of series of EBIT is stationary.

- **H_{1B}**. *The series of EBIT is not stationary. There is significant existence of the earnings management.*

As the computed p -value is lower than the significance level alpha, one should reject the null hypothesis H_{0B} , and accept the alternative hypothesis H_{1B} , based on Table 7. It is rejected following the KPSS test of stationarity for Level and Trend that the series of EBIT is stationary. These results confirm the conclusions of previous tests of no stationarity in managerial activities but significant managing earnings in Slovak and Bulgarian enterprises.

Table 7. Kwiatkowski–Phillips–Schmidt–Shin (KPSS) test.

KPSS Test	Observed Value		Critical Value		p -Value (One-Tailed)		Alpha
	Slovakia	Bulgaria	Slovakia	Bulgaria	Slovakia	Bulgaria	
Level	0.893	0.912	0.459	0.459	<0.0001	<0.0001	0.05
Trend	0.939	0.967	0.149	0.149	0.007	0.002	0.05

Source: own research.

Thirdly the existence of a significant change in the earnings management is detected. After the identification of significant occurrence of earnings management in both countries, it is required to determine if the mean of the development is homogenous all the time or if the heterogeneity exists (significant change of mean). Von Neumann's test is run to detect the homogeneity of the series of EBIT.

- **H_{1C}.** *The series of EBIT is heterogeneous. There is a significant change in the earnings management.*

The p -value of von Neumann's test was computed using 1,000,000 Monte Carlo simulations. As the computed p -value is lower than the significance level alpha, one should reject the null hypothesis H_{0C} , and accept the alternative hypothesis H_{1C} , based on Table 8. It is rejected following the von Neumann test of homogeneities of EBIT. Thus, there is a significant change in the earnings management of Slovak and Bulgarian enterprises.

Table 8. von Neumann's test.

von Neumann's Test	Slovakia	Bulgaria
N	0.151	0.145
p -value (Two-tailed)	<0.0001	<0.0001
alpha	0.05	0.05

Source: own research.

4. Discussion

Von Neumann's test indicates heterogeneity in the series of EBIT, but not a year of the significant change. This situation may mark the occurrence of the year that divides the development of EBIT of Slovak and Bulgarian enterprises into two homogenous groups. These groups are differentiated by the year of the change, they do not have only one mean of the development, but each has own central mean line of the development. The standard normal homogeneity test is run to detect a year of a significant change in the earnings management and the values of both central mean lines of development labelled mu.

- **H_{1D}.** *The series of EBIT is heterogeneous. There is a year of a significant change in the earnings management.*

The p -value of SNHT was computed using 1,000,000 Monte Carlo simulations. As the computed p -value is lower than the significance level alpha, one should reject the null hypothesis H_{0D} , and accept the alternative hypothesis H_{1D} , based on Table 9. It is rejected following the SNHT that no year of a significant change of EBIT does exist. Table 9 and Figures 3 and 4 involve indicated year as well as indicated central mean lines of development. The year 2014 is the year of significant change in the earnings management of Slovak and Bulgarian enterprises. This year divides the development of EBIT and determines the individual central line. The difference between calculated central lines of EBIT of

Bulgarian and Slovak enterprises is not very noticeable. It is EUR 92,000 until 2014 and EUR 110,000 since 2014. The finding also confirms some parallel of these emerging economies.

Table 9. Standard normal homogeneity test (SNHT).

SNHT Test	Slovakia	Bulgaria
T_0	7.053	6.732
t (year of significant change)	2014	2014
μ_1 [thousand €]	895	987
μ_2 [thousand €]	1373	1483
p-value (Two-tailed)	0.008	0.008
alpha	0.05	0.05

Source: own research.

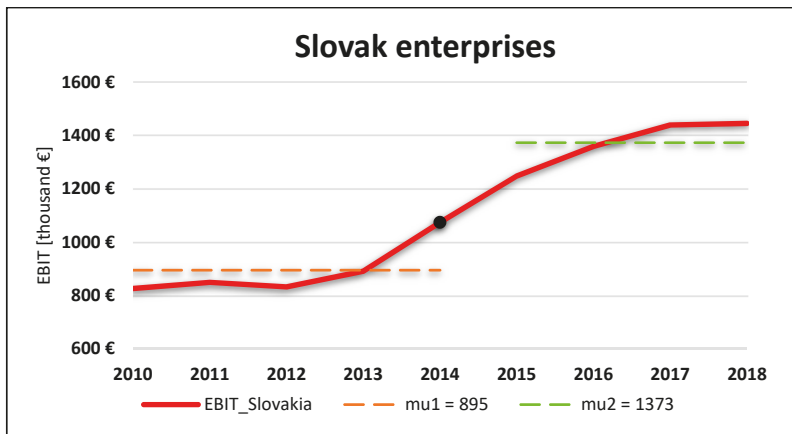

Figure 3. Significant change in the earnings management of Slovak enterprises. Source: own research.

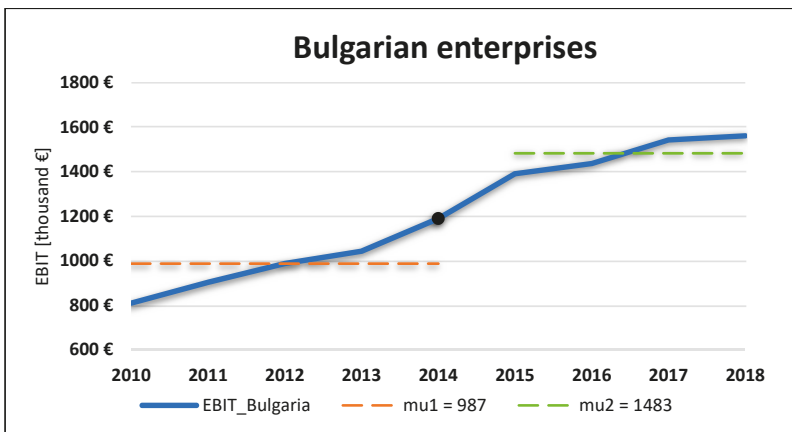

Figure 4. Significant change in the earnings management of Bulgarian enterprises. Source: own research.

Our findings concerned with the significance of the year 2014 for Slovak and Bulgarian enterprises are supported by Figure 5. It shows the rank of ease of doing business in Slovakia and Bulgaria. The lowest value of this index, the better for business. This year also divides the development of ease

of doing business as in the case of earnings management into two periods with very homogenous development within own group but very heterogeneous comparing the groups. The year 2014 saw a breaking point in the improvement of business conditions in both countries. These results of assessment of the business environment were expertly evaluated by global monitoring of the entrepreneurship (Madgerova et al. 2019).

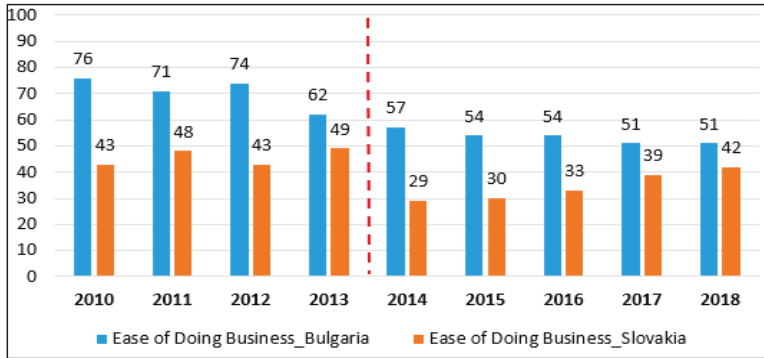

Figure 5. Ease of doing business rank. Source: own research.

The positive macroeconomic environment influences earnings manipulation of Slovak and Bulgarian enterprises and implicates significant change (heterogeneity) in the earnings management. Despite the ease of doing business rank, the positive macroeconomic environment in 2014 was represented by the annual growth rate of GDP, since this year it has been above zero and the annual growth rate has had rapid upward tendency (Figure 6). This year was the milestone also in decreasing of the long-term unemployment rank in both countries (Figure 7). Last but not least, Standard & Poor’s set positive outlook related to the credit rating for Slovakia and stable outlook for Bulgaria in the year 2014 (Trading Economics 2020) as well as the cohesion policy has changed new development environment within the European Union after the year 2014, based on the new programming period (Marin and Dimitrov 2018).

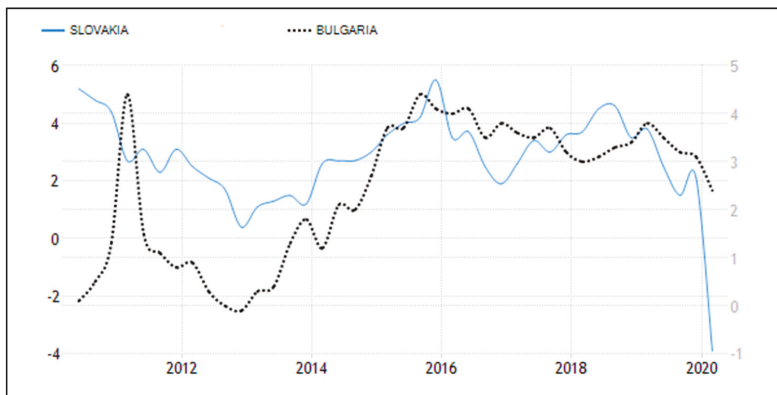

Figure 6. Annual growth rate of GDP. Source: Trading Economics.

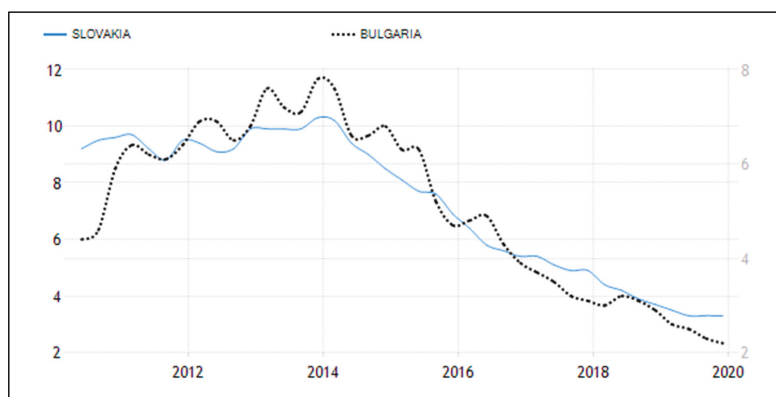

Figure 7. Long-term unemployment rank. Source: Trading Economics.

Our results are discussed with the last studies and investigations from emerging markets. [Cugova et al. \(2019\)](#) analyze various forms of earnings and the subsequent analysis of the profitability indicators of the engineering companies operating in the Slovak Republic. They analyze the period of 2012–2017. Both profits and profitability indicators show an increasing tendency, and in the last few years, they achieved impressive results. The performed analyses are only an elementary basis for earnings management. [Orazalin \(2019\)](#) focuses on earnings management activities of enterprises from Kazakhstan. This study indicates that enterprises with larger boards adopt a more restrained concept to earnings management manipulation. However, the conclusions deliver not significant proof of the connection among board independence and earnings quality. The study of [Orazalin and Akhmetzhanov \(2019\)](#) identify the force of earnings management and audit quality on the cost of debt in Kazakh enterprises. The result portrays that earnings management is negatively depended on the cost of debt. Their conclusions highlight higher audit quality means to a lower cost of debt and confirm no significant influence of audit quality on earnings management. [Valaskova et al. \(2019\)](#) evaluate the robustness of selected models in automotive of Slovakia. They analyze Jones' model and the modified Jones model, and find that the original Jones model is the most appropriate in identifying the earnings management in that environment. [Pavlovic et al. \(2019\)](#) investigate if the board of directors' age impact earnings management practices. The sample consists of all Serbian agriculture enterprises from Belgrade Stock Exchange for the interval of years 2013 to 2016. To detect the earnings management the modified Jones Model is used, which is shown as the most appropriate. The results indicate that there is no impact of board of directors' age on earnings management practices. They also find no evidence of the impact of the chairman's age on earnings management practices. Relationship between gender diversity and earnings management practices has not been found. [Pavlovic et al. \(2018\)](#) suggest that there is an insignificant negative linear relationship between the number of women in the board and earnings management. These findings are supported by the studies which indicate that the reasons for earnings management should be found in different factors, like cultural and political factors or religious attitude or age of the members of the boards but not on the gender differences. [Piosik and Genge \(2019\)](#), analyze enterprises from the Warsaw Stock Exchange in Poland and detect the negative dependency among total upward real earnings management and managerial ownership. Their study argues that specific tools of real earnings management are connected to the ownership assembly and managerial ownership in individual cases. [Sosnowski and Wawryszuk-Misztal \(2019\)](#) also used a sample from the Warsaw Stock Exchange and they reveal that some attributes of the supervisory board raise the effectivity of forward-focusing financial data connecting the initial public offering (IPO) prospectus, as some of boards attributes have the impact on the assessment of the earnings approximation credibility at the realizing of the IPO.

Sosnowski (2018) confirms no proof of the existence of private equity fund between the shareholders of the enterprise in the time of preceding first listing of stocks on a market constrains the applying of earnings management prior to the IPO. He does not reject that any significant discrepancy exists between the discretionary accruals in private equity backed and matched enterprises, when controlling for the market value and book-to-market ratio. Lizinska and Czapiewski (2018) disclose positive and significant discretionary accruals in the IPO year that can be considered as an indication of weak earning quality. They depict that analyzed accruals are indirectly depended on the subsequent long-term market value for IPOs realized before the global recession. Istrate (2019) confirms the increased rounding of earnings in a limited amount of units, even if the amplitude of identified gaps is really significant. The development of the accounting regulation tends to the state when it has begun preferring decreased modifications. The International Financial Reporting Standards (IFRS) transition does not tend to a limitation of the gap among the real occurrence and the normal one. This study finds out that smaller enterprises modify the net income not so significantly upward than the larger enterprises. Turlea et al. (2019) provide results from Romania concerned to the impact of granted by the auditor when the value of discretionary accruals is encountered and approximate the impact on the mandatory implementation of IFRS. They estimate the value of discretionary accruals by the value of residuals from two equations as regression models that calculate and detect the value of total accruals. The paper of Tanchev and Todorov (2019) examines the long-run and short-run tax buoyancies. They empirically test the impact of the buoyancy on income, profit, and consumption increases in Bulgaria.

5. Conclusions

The effective business finance is a key core of the success of all enterprises to be profitable in short as well as long-term period. The globally used phenomenon of earnings management allows a legal opportunity for the enterprises to make a purpose-built decision in the profit policy. Earnings management is widely realized in developed countries and the occurrence is comprehensively mapped. However, the aim of this paper was to detect the existence of earnings management in emerging countries by the times series analysis. Our results confirm that also managers of Slovak and Bulgarian enterprises are not static but significantly manage their earnings during the analyzed nine-year period. Earnings management creates an important part of coherent business finance. It supports the annual prosperity of the enterprises and presents a substantial tool of reducing risk in analyzed emerging countries.

The weakness of the provided research is the use of annual average values of EBIT. Panel data for the whole analyzed period may be used in further research. The analysis could be extended for all Soviet-controlled countries to disclose a comprehensive view on the issue of earnings management in these countries with similar historical and political development. We run only Dickey–Fuller test to detect the existence of significant change in the earnings management of Slovak and Bulgarian enterprises, not its modified versions. Further research may support these results by additional use of these tests. The standard normal homogeneity test was used to determine the year of a significant change in the earnings management of Slovak and Bulgarian enterprises, but this test is very sensitive when detecting the breaks near the beginning and the end of the series. Our results focus a priori on the parametric test. In the future investigations, the results of Dickey–Fuller tests may be compared with a nonparametric Phillips–Perron test, Kwiatkowski–Phillips–Schmidt–Shin test with the nonparametric test for stationarity in continuous-time Markov processes, von Neumann’s test and standard normal homogeneity test with nonparametric Pettitt’s test.

Author Contributions: Conceptualization, P.D. and V.K.; methodology, P.D.; software, P.D.; validation, D.C., V.K., K.V. and I.A.; formal analysis, V.K., K.V. and I.A.; investigation, P.D. and K.V.; resources, D.C., K.V. and I.A.; data curation, K.V.; writing—original draft preparation, P.D.; writing—review and editing, K.V.; visualization, P.D.; supervision, D.C., V.K., K.V. and I.A.; project administration, K.V.; funding acquisition, K.V. All authors have read and agreed to the published version of the manuscript.

Funding: This research received no external funding.

Acknowledgments: This research was financially supported by the Slovak Research and Development Agency—Grant NO. APVV-17-0546: Variant Comprehensive Model of Earnings Management in Conditions of the Slovak Republic as an Essential Instrument of Market Uncertainty Reduction and VEGA 1/0210/19: Research of innovative attributes of quantitative and qualitative fundamentals of the opportunistic earnings modeling.

Conflicts of Interest: The authors declare no conflict of interest.

References

- Agha, Omar M. A. Mahmood, Çağatay S. Bağcı, and Nermin Şarлак. 2017. Homogeneity analysis of precipitation series in North Iraq. *IOSR Journal of Applied Geology and Geophysics* 5: 57–63. [\[CrossRef\]](#)
- Alexandersson, Hans. 1986. A homogeneity test applied to precipitation data. *Journal of Climatology* 6: 661–75. [\[CrossRef\]](#)
- Andries, Katherleen, Martine Cools, and Steve Van Uytbergen. 2017. To shift or not to shift? Intertemporal income shifting as a response to the risk capital allowance introduction in Belgium. *European Accounting Review* 26: 531–59. [\[CrossRef\]](#)
- Archibald, T. Ross. 1967. The return to straight-line depreciation: An analysis of a change in accounting method. *Journal of Accounting Research* 5: 164–80. [\[CrossRef\]](#)
- Bai, Jushan, and Serena Ng. 2005. Tests for skewness, kurtosis, and normality for time series data. *Journal of Business & Economic Statistics* 23: 49–60.
- Balcerzak, Adam P., Tomas Kliestik, Dalia Streimikiene, and Lubos Smrcka. 2017. Non-parametric approach to measuring the efficiency of banking sectors in European union countries. *Acta Polytechnica Hungarica* 14: 51–70.
- Barefield, Russell M., and Eugene E. Comiskey. 1972. The smoothing hypothesis: An alternative test. *The Accounting Review* 47: 291–98.
- Ben Amar, Anis, and Salma Chakroun. 2018. Do dimensions of corporate social responsibility affect earnings managements? Evidence from France. *Journal of Financial Reporting and Accounting* 16: 348–70. [\[CrossRef\]](#)
- Beneish, Messod D. 1997. Detecting GAAP violation: Implications for assessing earnings management among firms with extreme financial performance. *Journal of Accounting and Public Policy* 16: 271–309. [\[CrossRef\]](#)
- Bera, Anil K., and Carlos M. Jarque. 1981. Efficient tests for normality, homoscedasticity and serial independence of regression residuals: Monte Carlo evidence. *Economics Letters* 7: 313–18. [\[CrossRef\]](#)
- Berti-Équille, Laure, Ji Meng Loh, and Tamraparni Dasu. 2015. A masking index for quantifying hidden glitches. *Knowledge and Information Systems* 44: 253–77. [\[CrossRef\]](#)
- Bowman, Kimiko O., and Lyndon R. Shenton. 1975. Omnibus test contours for departures from normality based on $\sqrt{b_1}$ and b_2 . *Biometrika* 62: 243–50. [\[CrossRef\]](#)
- Box, George E. P., and David A. Pierce. 1970. Distribution of residual autocorrelations in autoregressive-integrated moving average time series models. *Journal of the American statistical Association* 65: 1509–26. [\[CrossRef\]](#)
- Buishand, T. Adri. 1982. Some methods for testing the homogeneity of rainfall records. *Journal of Hydrology* 58: 11–27. [\[CrossRef\]](#)
- Burgstahler, David, and Illia Dichev. 1997. Earnings management to avoid earnings decreases and losses. *Journal of Accounting and Economics* 24: 99–126. [\[CrossRef\]](#)
- Bzeouich, Bilel, Faten Lakhel, and Neila Dammak. 2019. Earnings management and corporate investment efficiency: Does the board of directors mater? *Journal of Financial Reporting and Accounting* 17: 650–70. [\[CrossRef\]](#)
- Christensen, Hans B., Edward Lee, Martin Walker, and Cheng Zeng. 2015. Incentives or Standards: What determines accounting quality changes around IFRS adoption? *European Accounting Review* 24: 31–61. [\[CrossRef\]](#)
- Cimini, Riccardo. 2015. How has the financial crisis affected earnings management? A European study. *Applied Economics* 47: 302–17. [\[CrossRef\]](#)
- Copeland, Ronald M. 1968. Income smoothing. *Journal of Accounting Research* 6: 101–16. [\[CrossRef\]](#)

- Cugova, Aneta, Juraj Cug, and George Lazaroiu. 2019. Descriptive Analysis of Company's Profit as a Basis for Earnings Management. Paper presented at 33rd International-Business-Information-Management-Association (IBIMA) Conference: Education Excellence and Innovation Management Through Vision 2020, Granada, Spain, April 10–11; pp. 5629–38.
- Dascher, Paul E., and Robert E. Malcom. 1970. A note on income smoothing in the chemical industry. *Journal of Accounting Research* 8: 253–59. [CrossRef]
- DeAngelo, Linda Elizabeth. 1986. Accounting numbers as market valuation substitutes: A study of management buyouts of public stockholders. *Accounting Review* 61: 400–20.
- Dechow, Patricia M., and Douglas J. Skinner. 2000. Earnings management: Reconciling the views of accounting academics, practitioners, and regulators. *Accounting Horizons* 14: 235–50. [CrossRef]
- Dechow, Patricia M., Richard G. Sloan, and Amy P. Sweeney. 1995. Detecting earnings management. *Accounting Review* 70: 193–225.
- DeGeorge, Francois, Jayendu Patel, and Richard Zeckhauser. 1999. Earnings management to exceed thresholds. *The Journal of Business* 72: 1–33. [CrossRef]
- Dickey, David A., and Wayne A. Fuller. 1979. Distribution of the estimators for autoregressive time series with a unit root. *Journal of the American Statistical Association* 74: 427–31.
- Dopuch, Nicholas, and David D. Drake. 1966. The effect of alternative accounting rules for nonsubsidiary investments. *Journal of Accounting Research* 4: 192–219. [CrossRef]
- Dufour Jean-Marie, Abdeljelil Farhat, Lucien Gardiol, and Lynda Khalaf. 1998. Simulation-based finite sample normality tests in linear regressions. *Econometrics Journal* 1: 154–73. [CrossRef]
- Eldenburg, Leslie G., Katherine A. Gunny, Kevin W. Hee, and Naomi Soderstrom. 2011. Earnings management using real activities: Evidence from nonprofit hospitals. *The Accounting Review* 86: 1605–30. [CrossRef]
- Elder, John, and Peter E. Kennedy. 2001. Testing for unit roots: What should students be taught? *The Journal of Economic Education* 32: 137–46. [CrossRef]
- Ferrer Garcia, Cristina, and Jose Antonio Lainez Gadea. 2013. Detecting differences on the earnings quality measurement: Empirical evidence on Spanish firms. *Revista de Metodos Cuantitativos para la Economia y la Empresa* 16: 5–28.
- Garcia, Francisco Augusto Alcaraz. 2012. *Tests to Identify Outliers in Data Series*. Rio de Janeiro: Pontifical Catholic University of Rio de Janeiro, Industrial Engineering Department.
- Ghosh, Dhiren, and Andrew Vogt. 2012. Outliers: An evaluation of methodologies. *Joint Statistical Meetings*, 3455–60. Available online: <https://ww2.amstat.org/meetings/jsm/2012/onlineprogram/AbstractDetails.cfm?abstractid=304068> (accessed on 30 May 2020).
- Gordon, Myron J. 1964. Postulates, principles and research in accounting. *The Accounting Review* 39: 251.
- Gordon, Myron J., Bertrand N. Horwitz, and Philip T. Meyers. 1966. Accounting measurements and normal growth of the firm. *Research in Accounting Measurement* 23: 223–41.
- Graham, John R., Campbell R. Harvey, and Shiva Rajgopal. 2005. The economic implications of corporate financial reporting. *Journal of Accounting and Economics* 40: 3–73. [CrossRef]
- Guay, Wayne R., S. P. Kothari, and Ross L. Watts. 1996. A market-based evaluation of discretionary accrual models. *Journal of Accounting Research* 34: 83–105. [CrossRef]
- Gunny, Katherine A. 2010. The relation between earnings management using real activities manipulation and future performance: Evidence from meeting earnings benchmarks. *Contemporary Accounting Research* 27: 855–88. [CrossRef]
- Hacker, Scott R., and Abdunnasser Hatemi-J. 2010. *The Properties of Procedures Dealing with Uncertainty about Intercept and Deterministic Trend in unit Root Testing*. CESIS Electronic Working Paper Series; Stockholm: Centre of Excellence for Science and Innovation Studies, The Royal Institute of Technology, pp. 1–19.
- Healy, Paul. 1985. The impact of bonus schemes on the selection of accounting principles. *Journal of Accounting and Economics* 7: 85–107. [CrossRef]
- Hepworth, Samuel R. 1953. Smoothing periodic income. *The Accounting Review* 28: 32–39.
- Hoang, Trang Cam, and Dempsey Michael Joseph. 2019. The effect of new corporate accounting regime on earnings management: Evidence from Vietnam. *Journal of International Studies* 12: 93–104.
- Hoglund, Henrik. 2012. Detecting earnings management with neural networks. *Expert Systems with Applications* 39: 9564–70. [CrossRef]

- Hudakova, Maria, Matej Masar, Maria Luskova, and Milan Robin Patak. 2018. The dependence of perceived business risks on the size of SMEs. *Journal of Competitiveness* 10: 54–69. [\[CrossRef\]](#)
- Iatridis, George, and George Kadorinis. 2009. Earnings management and firm financial motives: A financial investigation of UK listed firms. *International Review of Financial Analysis* 18: 164–73. [\[CrossRef\]](#)
- Istrate, Costel. 2019. Detecting earnings management using Benford's Law: The case of Romanian listed companies. *Journal of Accounting and Management Information Systems* 18: 198–223. [\[CrossRef\]](#)
- Jarque, Carlos M., and Anil K. Bera. 1980. Efficient tests for normality, homoscedasticity and serial independence of regression residuals. *Economics Letters* 6: 255–59. [\[CrossRef\]](#)
- Jones, Jennifer J. 1991. Earnings management during import relief investigations. *Journal of Accounting Research* 29: 193–228. [\[CrossRef\]](#)
- Kang, Ho Ming, and Fadhilah Yusof. 2012. Homogeneity tests on daily rainfall series. *International Journal of Contemporary Mathematical Sciences* 7: 9–22.
- Kanovsky, Martin. 2018. The research effectivity of Slovak universities: Quantitative analysis of trends 2008–2017. *Slovak Sociological Review* 50: 429–47. [\[CrossRef\]](#)
- Kaplan, Robert S. 1985. Evidence on the effect of bonus schemes on accounting procedure and accrual decisions. *Journal of Accounting and Economics* 7: 109–13. [\[CrossRef\]](#)
- Kempen, R. 2010. Earnings Management in Public and Private Companies in the Netherlands. Master's thesis, Accounting and Finance, Erasmus University Rotterdam, Rotterdam, The Netherlands; pp. 1–32.
- Khanh, Hoang Mai Thi, and Anh Phung Thu. 2019. The effect of financial leverage on real and accrual-based earnings management in Vietnamese firms. *Economics and Sociology* 12: 299–333. [\[CrossRef\]](#)
- Kral, Pavol, Viera Valjaskova, and Katarina Janoskova. 2019. Quantitative approach to project portfolio management: Proposal for Slovak companies. *Oeconomia Copernicana* 10: 797–814. [\[CrossRef\]](#)
- Kwiatkowski, Denis, Peter C. B. Phillips, Peter Schmidt, and Yongcheol Shin. 1992. Testing the null hypothesis of stationarity against the alternative of a unit root. *Journal of Econometrics* 54: 159–78. [\[CrossRef\]](#)
- Leybourne, Stephen. J., Terence C. Mills, and Paul Newbold. 1998. Spurious rejections by Dickey–Fuller tests in the presence of a break under the null. *Journal of Econometrics* 87: 191–203. [\[CrossRef\]](#)
- Lizinska, Joanna, and Leszek Czapiewski. 2018. Towards economic corporate sustainability in reporting: What does earnings management around equity offerings mean for long-term performance? *Sustainability* 10: 4349. [\[CrossRef\]](#)
- Ljung, Greta M., and George E. P. Box. 1978. On a measure of lack of fit in time series models. *Biometrika* 65: 297–303. [\[CrossRef\]](#)
- Madgerova, Raya, Vyara Kyurova, Anny Atanasova, and Blagovesta Koyundzhiyska-Davidkova. 2019. Study of the business environment for the development of youth entrepreneurship in Bulgaria. Theoretical and practical aspects. *Revista Inclusiones* 6: 90–104.
- Marin, Nikolay, and Preslav Dimitrov. 2018. Economic Effects of the membership of the Republic of Bulgaria in the European Union. *Kutafin University Law Review* 5: 209–21.
- McNichols, Maureen, and Peter G. Wilson. 1988. Evidence of earnings management from the provision for bad debts. *Journal of Accounting Research* 26: 1–31. [\[CrossRef\]](#)
- Meyers, Thomas D., Ladislav Vagner, Katarina Janoskova, Iulia Grecu, and Gheorghe Grecu. 2019. Big data-driven algorithmic decision-making in selecting and managing employees: Advanced predictive analytics, workforce metrics, and digital innovations for enhancing organizational human capital. *Psychosociological Issues in Human Resource Management* 7: 49–54.
- Nagy, Ladislav. 2016. Ratio indicators database of HGN1 model for measuring enterprise performance. *Journal of Knowledge Society* 4: 1–11.
- Orazalin, Nurlan. 2019. Board gender diversity, corporate governance, and earnings management. *Gender in Management* 35: 37–60. [\[CrossRef\]](#)
- Orazalin, Nurlan, and Rassul Akhmetzhanov. 2019. Earnings management, audit quality, and cost of debt: Evidence from a Central Asian economy. *Managerial Auditing Journal* 34: 696–721. [\[CrossRef\]](#)
- Pavlovic, Vladan, Goranka Knezevic, and Radica Bojicic. 2018. Board gender diversity and earnings management in agricultural sector—Does it have any influence? *Custos E Agronegocio On Line* 14: 340–63.
- Pavlovic, Vladan, Goranka Knezevic, and Radica Bojicic. 2019. Does board of director's age impact earnings management in agriculture? Case of Serbian agricultural sector. *Custos E Agronegocio on Line* 15: 254–72.

- Peasnell, Ken V., Peter F. Pope, and Steven Young. 2000. Detecting earnings management using cross-sectional abnormal accruals models. *Accounting and Business Research* 30: 313–26. [CrossRef]
- Penman, Stephen H., and Xiao-Jun Zhang. 2002. Accounting conservatism, the quality of earnings, and stock returns. *The Accounting Review* 77: 237–64. [CrossRef]
- Pina, Vicente, Maria Jose Arcas, and Caridad Marti. 2012. Accruals and accounting numbers management in UK executive agencies. *Public Money & Management* 32: 273–80.
- Piosik, Andrzej, and Ewa Genge. 2019. The influence of a company's ownership structure on upward real earnings management. *Sustainability* 12: 152. [CrossRef]
- Pohlert, Thorsten. 2016. Non-Parametric Trend Tests and Change-Point Detection. *Creative Commons License (CC BY-ND 4.0)*. Available online: <https://mran.microsoft.com/snapshot/2016-06-30/web/packages/trend/vignettes/trend.pdf> (accessed on 30 March 2020).
- Rahman, Ashiqur, Jaroslav Belas, Tomas Klietstik, and Ladislav Tyll. 2017. Collateral requirements for SME loans: Empirical evidence from the Visegrad countries. *Journal of Business Economics and Management* 18: 650–75. [CrossRef]
- Rodriguez-Perez, Gonzalo, and Stefan van Hemmen. 2010. Debt, diversification and earnings management. *Journal of Accounting and Public Policy* 29: 138–59. [CrossRef]
- Roychowdhury, Sugata. 2006. Earnings management through real activities manipulation. *Journal of Accounting and Economics* 42: 335–70. [CrossRef]
- Sosnowski, Tomasz. 2018. Earnings management in the private equity divestment process on Warsaw Stock Exchange. *Equilibrium. Quarterly Journal of Economics and Economic Policy* 13: 689–705. [CrossRef]
- Sosnowski, Tomasz, and Anna Wawryszak-Misztal. 2019. Diversity on management and supervisory board and accuracy of management earnings forecasts in IPO prospectuses. *Ekonomia i Prawo. Economics and Law* 18: 347–63. [CrossRef]
- Spuchlakova, Erika, and Juraj Cug. 2015. Credit risk and LGD modelling. *Procedia Economics and Finance* 23: 439–44. [CrossRef]
- Tanchev, Stoyan, and Ivan Todorov. 2019. Tax buoyancy and economic growth: Empirical evidence of Bulgaria. *Journal of Tax Reform* 5: 236–48.
- Susanto, Yulius Kurnia, Kashan Pirzada, and Adrienne Sheryl. 2019. Is tax aggressiveness an indicator of earnings management? *Polish Journal of Management Studies* 20: 516–27.
- Svabova, Lucia, and Marek Durica. 2019. Being an outlier: A company non-prosperity sign? *Equilibrium. Quarterly Journal of Economics and Economic Policy* 14: 359–75. [CrossRef]
- Svabova, Lucia, and Lucia Michalkova. 2018. Pre-processing of data in earnings management. *Business Economics and Management* 3: 65–72.
- Trading Economics. 2020. Available online: <https://tradingeconomics.com/indicators> (accessed on 20 April 2020).
- Turlea, Carmen, Laura Brad, Florin Dobre, and Ioan Codrut Turlea. 2019. The Influence of Financial Auditor on the Earnings Management Process: Mandatory Application of IFRS for the First Time in Romania. Paper presented at BASIQ International Conference on New Trends in Sustainable Business and Consumption, Bari, Italy, May 30–June 1.
- Vagner, Ladislav. 2017. Facility Management as a Partner of Cost Controlling at Costs Optimization in the Selected Enterprise. Paper presented at 17th Annual Conference on Finance and Accounting: New Trends in Finance and Accounting, Prague, Czech Republic, May 27; pp. 621–29.
- Valaskova, Katarina, Tomas Klietstik, and Maria Kovacova. 2019. Assessment of Selected Models of Earnings Management in Economic Conditions of Slovakia. Paper presented at 33rd International-Business-Information-Management-Association (IBIMA) Conference Education Excellence and Innovation Management Through Vision 2020, Granada, Spain, April 10–11; pp. 3922–31.
- Velte, Patrick P. 2019. The bidirectional relationship between ESG performance and earnings management—Empirical evidence from Germany. *Journal of Global Responsibility* 10: 322–38. [CrossRef]
- Von Neumann, John. 1941. Distribution of the ratio of the mean square successive difference to the variance. *The Annals of Mathematical Statistics* 12: 367–95. [CrossRef]

White, Gary E. 1970. Discretionary accounting decisions and income normalization. *Journal of Accounting Research* 8: 260–73. [[CrossRef](#)]

Young, Steven. 1999. Systematic measurement error in the estimation of discretionary accruals: An evaluation of alternative modelling procedures. *Journal of Business Finance & Accounting* 26: 833–62.



© 2020 by the authors. Licensee MDPI, Basel, Switzerland. This article is an open access article distributed under the terms and conditions of the Creative Commons Attribution (CC BY) license (<http://creativecommons.org/licenses/by/4.0/>).

Article

A Raroc Valuation Scheme for Loans and Its Application in Loan Origination

Bernd Engelmann and Ha Pham *

Faculty of Finance-Banking, Ho Chi Minh City Open University, 35-37 Ho Hao Hon, Dist 1, Ho Chi Minh City 700000, Vietnam; bernd.engelmann@ou.edu.vn

* Correspondence: ha.p@ou.edu.vn

Received: 27 April 2020; Accepted: 4 June 2020; Published: 10 June 2020

Abstract: In this article, a risk-adjusted return on capital (RAROC) valuation scheme for loans is derived. The critical assumption throughout the article is that no market information on a borrower's credit quality like bond or CDS (Credit Default Swap) spreads is available. Therefore, market-based approaches are not applicable, and an alternative combining market and statistical information is needed. The valuation scheme aims to derive the individual cost components of a loan which facilitates the allocation to a bank's operational units. After its introduction, a theoretical analysis of the scheme linking the level of interest rates and borrower default probabilities shows that a bank should only originate a loan, when the interest rate a borrower is willing to accept is inside the profitability range for this client. This range depends on a bank's internal profitability target and is always a finite interval only or could even be empty if a borrower's credit quality is too low. Aside from analyzing the theoretical properties of the scheme, we show how it can be directly applied in the daily loan origination process of a bank.

Keywords: loan pricing; RAROC; loan origination

JEL Classification: C69; C19

1. Introduction

A loan is probably the most traditional banking product. However, when different people in different countries or even different people in the same country working in different customer segments speak about a loan, and they probably do not speak about the same product. The only common feature is that a lender gives money to a borrower and hopes to get back more than he has lent. Besides that, differences can be substantial. Critical drivers of product structure are the availability of funding and collateral. In some countries, only short-term funding is available to a bank. For this reason, interest rates of loans are rarely fixed over a long-term horizon but can be adjusted by a bank on short notice. In other countries, long-term funding is available, and loans are often fixed-rate or floating-rate loans, where the floating rate follows an objective rule like 6M Ibor plus a spread.¹ The most prominent type of loans that is linked to a particular collateral type is the mortgage. Here, often long maturities up to 30 years are observed. However, still, there are some differences between countries. For instance, in the US, a borrower can pass the key of a house to a bank when the house loses in value while in Germany defaulting on a mortgage is not that easy, and the borrower still is responsible for the residual amount between the loan balance and house value. There are a lot more differences. In some countries, borrowers have prepayment rights on their loans; in other countries, prepayment rights

¹ In this article, Ibor stands for all kinds of official floating rates like Libor, Euribor, etc.

are less popular, but floating-rate loans are embedded with caps and floors. A lot more covenants can be included, like interest rates that increase with rating downgrades or minimum requirements on collateral value.

In this article, we develop a loan pricing scheme based on risk-adjusted return on capital (RAROC) as a performance measure. The purpose of this article is twofold. First, we propose a scheme that is directly implementable in banking practice drawing on input data that is readily available in most banks. This data consists of quotes from the interbank market, like deposit and swap rates, internal costs for funding and operation, and credit risk parameters related to borrower and collateral, i.e., statistical default probabilities and loss rates. We explicitly assume that no market information related to borrower credit quality, like bond or CDS spreads, is observable.

The proposed scheme is most valuable during loan origination where it provides a bank not only with the loan performance related to a particular offer of the loan's interest rate but, in addition, with a decomposition of the interest rate into cost components associated with different bank operations related to lending. These are the funding of a bank loan by deposits, the management of loss risks, the hedging of interest rate risks, and the coverage of operational costs. Therefore, the scheme could be helpful in determining fund transfer prices between a bank's operational units.

In addition, the scheme delivers a loan valuation. This could be valuable in price negotiations when loan portfolios are sold to investors. In economies with negative interest rate like the European Union, life insurers and pension funds are increasingly attracted by residential mortgages (European Central Bank 2019) where they are still able to get a positive return in contrast to most government bonds. To determine a price during sales negotiations and for the investor's ongoing reporting, our proposed model could be applied.

The second contribution of this article is an analysis of the RAROC scheme's theoretical properties. Roughly speaking, RAROC is defined as $(\text{interest income} - \text{costs}) / \text{capital}$. On first glance this means if a bank would raise interest rates, leaving all other quantities unchanged, profitability would increase. However, it is intuitively clear that raising interest payments beyond the income of a borrower or the profit of a firm will lead to a default. This means, an economically meaningful performance measure should reflect this by having a low value in this scenario. We will show that, when properly relating borrower default probability and loan interest rate, this is indeed reflected by RAROC, i.e., that there is only a finite interval of interest rates where it is economically sensible for a bank to originate a loan. The market power of banks in a particular loan segment will then determine whether a bank can originate a loan at the lower or the upper end of this interval. This interval might be empty in cases where a borrower's credit quality is too low, meaning that a bank should not originate a loan to this borrower regardless of the interest rate.

The general pricing framework presented in this article is not linked to a particular loan segment and is applicable both for corporate and retail lending. In the next Section, we will provide a literature review. In Section 3, the loan pricing formula and its parameterization will be explained. In Section 4, the RAROC pricing scheme will be developed, and the calculation of all its cost components will be derived. After that, in Section 5 the theoretical properties of this scheme will be analyzed by linking the level of interest rates to the default rates of a borrower, and it will be shown how meaningful loan acceptance rules can be derived. In Section 6, numerical examples are presented for illustration. The final Section concludes.

2. Literature Review

Our aim is developing a RAROC scheme that is applicable in banks world-wide drawing on inputs that are readily available in most banks. This is data related to internal costs and risk parameters measured statistically possible amended by expert judgment. As already outlined in the introduction, we explicitly assume that there is no market information of a borrower available, i.e., the borrower did not issue any bonds but all his debt consists exclusively of bank loans. This implies that the stream of literature using risk-neutral probabilities for asset pricing, e.g., as in Jarrow et al. (1997) or

Choi et al. (2020), which are based on trading strategies in arbitrage-free markets, is not applicable in this context. A recent article on fair value approaches for loans is Skoglund (2017) where the utilization of market data for loan valuation is discussed. In most loan markets world-wide this is not feasible since the required market data is available only in countries with developed capital markets. Even in these countries, market valuations can only be applied to a small segment of the loan market, typically large corporates.

The RAROC concept dates back to the 70s, where it has been developed by practitioners. Often, it is applied in a one-period model analyzing one year only even if the loan maturity is longer (Crouhy et al. 1999). The earliest extensions of RAROC to a multi-period framework are Aguais et al. (1998); Aguais and Forest (2000); Aguais and Santomero (1998). However, the description is very sketchy and loan pricing aspects that became important after the financial crisis are, of course, not included since these articles were written well before. Besides that, there is no split of the interest rate into cost components related to different operational units of a bank provided. Closing this gap is one purpose of this article.

When applying a RAROC scheme in practice, a number of aspects have to be considered that are not covered by our work but are required as inputs. These are the definition of capital for performance measurement, the allocation of total bank capital to sub-units, and the determination of target equity returns. As outlined in the introduction, RAROC is broadly defined as $(\text{interest income} - \text{costs})/\text{capital}$. There are two definitions of capital, regulatory capital that is defined by supervisory rules Basel Committee on Banking Supervision (2006, 2011), and economic capital. Economic capital is measured by a credit portfolio model that should reflect economic reality more closely than the regulatory rules, e.g., by quantifying concentration risks. Most economic capital models are based on Gupta et al. (1997) and CSFB (1997). Once the loss distribution of a credit portfolio is computed a risk measure is derived. Usually expected shortfall is used to compute portfolio risk and the risk is distributed among the single credits in a process called capital allocation. For details see Kalkbrener et al. (2004), Kalkbrener (2005) and Balog et al. (2017). Both academia and practice have used predominantly economic capital models for performance measurement. A recent study is Chun and Lejeune (2020) where a multi-period model for loan pricing and profit maximization in an economic capital framework is developed. Compared to our work they do not model the interaction of default probabilities and interest rates but link the interest rate to a probability that a borrower accepts a loan offer. Besides that, their framework cannot be used for fund transfer pricing as they do not provide a loan's cost components.

As pointed out by Klaassen and Van Eeghen (2018), economic capital usually exceeded regulatory capital in the past. For this reason, measuring loan performance by economic capital did not interfere with the regulatory rules since it was more conservative. However, this has changed with the recent Basel reforms resulting in higher minimum requirements of regulatory capital. When regulatory capital is higher than economic capital, performance measurement based on economic capital no longer works because it is overstating true performance. This motivated banks to move from economic to regulatory capital for performance measurement, as confirmed by a survey in (Ita 2016, p. 38), and recent empirical research (Akhtar et al. 2019; Oino 2018). The RAROC scheme in this article does not depend on a particular capital definition and will work with either economic or regulatory capital. We will use regulatory capital for illustration and concrete examples because it is more tractable and increasingly more common in practice.

An important process where RAROC (or the related alternative RORAC) is applied, is the allocation of bank capital to business units. Here, a bank faces the problem that the managers of business units, who have only limited information about the total bank, should optimize the performance of their unit in a way leading to the maximum performance of the organization. The first article, demonstrating the usefulness of RAROC for this purpose is Stoughton and Zechner (2007). Extensions of this work are Buch et al. (2011), Baule (2014), Turnbull (2018) and Kang and Poshakwale (2019) where the latter even empirically demonstrate the usefulness of this approach. In this article, we do not analyze capital allocation on the business unit level but assume

that this is done already. Instead, we focus on the loan-level and the costs and risks associated with each individual loan.

To evaluate loan performance, banks have to define a profitability target for their equity capital. This could be done by an application of the CAPM (Capital Asset Pricing Model). As pointed out by Crouhy et al. (1999) a uniform hurdle rate for all banking activities could lead to erroneously rejecting low-risk and accepting high-risk loans. Miu et al. (2016) propose a framework where target profitability can be defined on a granular basis for loan segments more accurately reflecting their riskiness. However, the application of their framework requires traded equity of borrowers, which limits its usefulness to a small part of the global loan markets. The determination of profitability targets is not part of this article. We assume this has been defined either quantitatively or by expert judgment, bank-wide or individually for loan segments. Since we focus on the individual loan, the scheme will work with either definition of profitability target.

Finally, we point out that we do not model the interaction of borrowers and lenders or the loan market as a whole. Modeling loan prices using equilibrium models is done, for instance, in Greenbaum et al. (1989); Repullo and Suarez (2004) and Dewasurendra et al. (2019). While these models shed some insights on the effect of regulatory rules on loan prices, they are of limited practical value as they miss out important aspects like loan structure or costs for interest rate risk management. An interesting example of modeling the borrower–lender interaction is Zhang et al. (2020) analyzing the special case of retailers loan decision in inventory financing under different bank loan offerings depending on the regulatory regime. In this article, we entirely focus on the bank and the costs associated with a loan. We will derive a set of interest rates under which it is profitable for a bank to offer a loan. Under what conditions or if at all a prospective borrower will accept an offer, is not part of this work.

3. Loan Pricing Formula

In this Section, the loan pricing formula and its parameterization are outlined. This formula builds the basis of the RAROC pricing scheme, which is explained in the next Section. Some aspects of the parameterization might not be apparent immediately but will be justified in the next Section. The value of a loan will be defined as the expected present value of all future cash flows. These are the interest rate payments, the amortization payments of the loan’s notional, and the liquidation proceeds of collateral in the case of a borrower default. The general expression for a loan’s value V at time t is given as

$$V(t) = \sum_{t < T_i} (N_i z_i \tau_i + A_i) \delta(T_i) v(T_i) + \sum_{t < T_i} N_i R_i \delta(T_i) (v(T_{i-1}^*) - v(T_i)), \tag{1}$$

where T_i is the interest rate payment time in period i , $T_{i-1}^* = \max(T_{i-1}, t)$, τ_i is the year fraction of interest period i , N_i the outstanding notional in each period, A_i the amortization payments, R_i the recovery rate in case of a default in period i , $\delta(T_i)$ is the discount factor corresponding to time T_i , and $v(T_i)$ the survival probability of the borrower up to time T_i . It is assumed that default is recognized in payment times only and that the recovery rate summarizes the liquidation proceeds in case of default discounted back to default time.

The quantities N_i , A_i , and z_i are defined by the loan terms. The amortization payments depend on the loan structure, i.e., whether the loan is a bullet loan, an installment loan or an annuity loan. The interest rate z_i could be fixed or floating. In the case of a fixed-rate loan, the interest rate in each period is y , where we assume that y is fixed and period-independent. In the case of a floating-rate loan, the interest rate is $(L_i + s)$, where L_i is an Ibor rate, which is fixed at the beginning of each interest rate period i and s is a spread that is assumed constant throughout the loan’s lifetime. We will use the notation z_i for the interest rate in period i with

$$z_i = \begin{cases} y, & \text{if the loan’s interest rate is fixed,} \\ f_i + s, & \text{if the loan’s interest rate is floating,} \end{cases} \tag{2}$$

where f_i is the forward rate corresponding to the floating rate L_i . To compute forward rates a second discount curve is needed, which will be denoted with $\delta_M(t)$. Forward rates are computed as

$$f_i = \frac{1}{\tau_i} \left(\frac{\delta_M(T_{i-1})}{\delta_M(T_i)} - 1 \right). \tag{3}$$

It remains to explain how the parameters discount factors, survival probabilities, and recovery rates are determined. This is done in a separate subsection for each parameter.

3.1. Discount Factors

The pricing Formula (1) requires two discount curves, the discount curve for discounting cash flows and the forward curve for computing forward rates for floating-rate loans. The forward curve is computed from the money market and the swap market. Usually, the forward curve up to one year is computed from deposit rates and forward rate agreements. Swap rates exist for maturities from one year up to 30 years in some currencies. A swap rate s_{fix} is the fixed-rate of a swap, which periodically exchanges the fixed-rate with a Ibor rate L_s with tenor Λ_s . If the loan is linked to the same Ibor rate the discount factors δ_M can be computed from the relation

$$s_{fix} = \frac{\delta_{M,\Lambda_s}(U_0) - \delta_{M,\Lambda_s}(U_{\hat{m}})}{\sum_{j=1}^{\hat{m}} \eta_j \delta_{M,\Lambda_s}(U_j)}, \tag{4}$$

where U_0 is the start date of the swap, U_j are the payment times of the fixed leg and η_j are the day count fractions of the fixed leg. Usually, a bootstrap algorithm is applied in computing δ_M starting from the swap rate with the lowest maturity and moving forward in swap maturities iteratively using the results of the previous calculation to compute the discount factors corresponding to higher maturities.

If the loan is linked to a different Ibor rate L_l with tenor Λ_l , the above curve cannot be used for computing forward rates. The spread of a basis swap exchanging periodically Ibor payments with tenor Λ_s for Ibor payments with tenor Λ_l has to be added to s_{fix} before the bootstrapping starts. We assume the basis swap exchanges $L_s + s_B$ for L_l , where s_B is the basis swap spread which depends on the maturity of the basis swap and can be negative.² This changes Equation (4) to

$$s_{fix} + s_B = \frac{\delta_{M,\Lambda_l}(U_0) - \delta_{M,\Lambda_l}(U_{\hat{m}})}{\sum_{j=1}^{\hat{m}} \eta_j \delta_{M,\Lambda_l}(U_j)}. \tag{5}$$

The discount curve δ has to reflect the funding conditions of a bank. It is computed from the fund transfer prices that are provided by a bank’s treasury. Typically fund transfer prices are given for a grid of standardized tenors like, 1Y, 2Y, . . . , 10Y and are provided as Ibor + spread. This means, that internally the credit department buys a bond from the treasury department with a notional equal to the amount they intend to lend to a borrower. The coupon of this funding instrument is linked to a Ibor rate L_f with tenor Λ_f plus a spread s_f depending on a loan’s maturity. The discount curve δ_f can be computed from the relation

$$1 = \sum_{j=1}^{\hat{m}} (f_{j,\Lambda_f} + s_f) \xi_i \delta_f(W_i) + \delta_f(W_{\hat{m}}), \tag{6}$$

where W_i are interest rate payment times of the funding bond and ξ_i are the year fractions of the interest rate periods. The forward rates f_{j,Λ_f} are computed by (3) using the swap curve linked to L_f . For the calculation of discount factors, the notional is normalized to 1. Similar to the bootstrapping of the swap curve, a bootstrapping of the funding curve can be performed starting from the lowest

² This means that in reality, $L_l + s_B$ is exchanged for L_s .

maturity and working iteratively up to the highest. If a loan has a fixed rate of interest or a floating rate linked to the Ibor rate L_f we get the discount factors in (1) as $\delta = \delta_f$.

If the loan’s interest rate is floating and its Ibor’s tenor $\Lambda_l \neq \Lambda_f$ again an adjustment by basis swap spreads is needed. Assume that the basis swap for L_l and L_f exchanges $L_l + s_{\beta}$ for L_f where again s_{β} might be negative. Equation (6) has to be adjusted to

$$1 = \sum_{j=1}^m (f_{j,\Lambda_l} + s_f + s_{\beta}) \tau_i \delta(T_i) + \delta(T_m), \tag{7}$$

where the payment times and year fractions in (7) are the same as for the loan. Forward rates f_{j,Λ_l} are computed from the swap curve corresponding to the Ibor rate L_l . Bootstrapping this relation results in the discount curve needed for discounting a loan’s cash flows. Why this is a sensible discount curve for cash flow discounting will become clear in Section 4.

3.2. Survival Probabilities

Equivalent to the calculation of a survival probability $v(T)$ up to time T is the calculation of a default probability $p(T) = 1 - v(T)$. Default probabilities with a time horizon of one year are typically one outcome of a bank’s rating system. We assume that a bank’s rating system has n grades where the n -th grade is the default grade. Again, remember that one key assumption of this article was the absence of market information like bond or CDS spread. Therefore, a bank has to rely on statistical information which is derived using balance sheet information for corporate clients, personal information of retail clients, and expert judgment as inputs. There are typically two ways of how banks could extract statistical information about defaults from their rating systems to estimate multi-year default probabilities.

In the first approach, a one-year transition matrix is estimated from the rating transitions that are observed in a bank’s rating system. The resulting matrix is denoted with $\mathbf{P}(1)$. The entries of the matrix are denoted with p_{kl} , $k, l = 1, \dots, n$ where p_{kl} is the probability that a borrower in rating grade k moves to grade l within one year. The matrix $\mathbf{P}(1)$ has the following properties:

1. The entries of $\mathbf{P}(1)$ are nonnegative, i.e., $p_{kl} \geq 0, k, l = 1, \dots, n$.
2. All rows of $\mathbf{P}(1)$ sum to one, i.e., $\sum_{l=1}^n p_{kl} = 1, l = 1, \dots, n$.
3. The last column $p_{kn}, k = 1, \dots, n - 1$ contains the one-year default probabilities of the rating grades $1, \dots, n - 1$.
4. The default state is absorbing, i.e., $p_{nl} = 0, l = 1, \dots, n - 1$ and $p_{nn} = 1$.

If we assume that rating transitions are Markovian, i.e., they depend on a borrower’s current rating grade only, and that transition probabilities are time-homogeneous, i.e., the probability of a rating transition between two-time points depends on the length of the time interval only, then it is possible to apply the theory of Markov chains to construct transition matrices $\mathbf{P}(h)$ for an arbitrary full-year h just by multiplying $\mathbf{P}(1)$ with itself:

$$\mathbf{P}(h) = \underbrace{\mathbf{P}(1) \cdot \dots \cdot \mathbf{P}(1)}_{h \text{ times}}. \tag{8}$$

Once $\mathbf{P}(h)$ is computed, the default probability $p_k(h)$ can be read from the last column in the k -th row. Interpolating the values $p_k(h)$ gives the term-structure of default probabilities for rating grade k .

In the second approach, banks directly estimate a term-structure of default probabilities, i.e., for each rating grade k a function $p_k(T)$ is estimated where $p_k(T)$ is the probability that a borrower in rating grade k will default within the next T years. From the term structure of default probabilities given today, conditional default probabilities for future times U can be computed easily. The probability

$p_k(T|U)$ that a borrower in rating grade k will default up to time T conditional that he is alive at time U is given by

$$p_k(T|U) = 1 - \frac{1 - p_k(T)}{1 - p_k(U)}, \quad U < T. \tag{9}$$

One way of estimating $p_k(T)$ is by using techniques from survival analysis, where the Cox proportional hazard model has been successfully applied in a credit risk context by numerous authors. Examples are [Banasik et al. \(1999\)](#) and [Malik and Thomas \(2010\)](#). In this model, $p(T)$ is parameterized as

$$p(T) = 1 - \exp \left(- \exp \left(\beta_0 + \sum_{i=1}^l \beta_i K_i \right) \int_0^T h(u) du \right), \tag{10}$$

where β_i are model coefficients, K_i borrower-dependent risk factors like balance sheet ratios for companies or personal data for retails clients and $h(u)$ a borrower-independent baseline hazard function. Borrowers with similar $p(1)$ can be summarized into a rating category k and are then represented by the curve $p_k(T)$.

Throughout this article, we will assume that $p_k(T)$ is estimated by a Cox proportional hazard model as in (10). However, this is by no means the only way to estimate a default probability (PD) term-structure. A good overview of available methodologies is provided in [Crook and Bellotti \(2010\)](#).

3.3. Recovery Rates

Recovery rates reflect the degree of collateralization of a loan. They can be period-dependent. For instance, if a loan is amortizing and the collateral value stays the same over a loan’s lifetime, a loan becomes less risky over the years. This should be reflected in an increasing recovery rate. One pragmatic way to include collateral in a loan pricing framework is to provide the collateral value as input. This collateral value should not be the current market value of collateral but include the loss given default (LGD) of the collateral, i.e., the expected loss in value in the case of a borrower default. This loss can stem from price reductions in a distressed sale or reflect the costs of a liquidation process, e.g., for lawyers. Overall, the collateral valuation and LGD estimation process is complex and beyond the scope of this article. Some ideas can be found in articles on LGD estimation in [Engelmann and Rauhmeier \(2006\)](#).

For the purpose of loan pricing, we assume that such a process exists and that the outcome is a collateral cash value C . For the unsecured part of a loan, a bank estimates a recovery rate R^u . From these data, the recovery rate R_i in each period is computed as

$$R_i = \min \left(100\%, \frac{C + R^u \max(N_i - C, 0)}{N_i} \right) \tag{11}$$

In (11) a cap of 100% was introduced. It depends on the specific legal environment of a country’s loan market, whether recovery rates of more than 100% are possible or not. In case recovery rates can be larger than 100%, this assumption can be relaxed.

Note, that when applying this approach, consistency is an important issue. In (11) the recovery rate is related to the outstanding notional. In internal risk parameter estimation processes, recovery rates (or, equivalently, LGD values) are often estimated with respect to outstanding notional plus one interest payment. Since loan pricing and risk parameter estimation is usually done in different departments of a bank, one has to take some care to ensure that consistent definitions and assumptions are used throughout a bank. Where this is not the case, appropriate transformations have to be defined.

4. RAROC Scheme

The main purpose of this Section is the derivation of a RAROC scheme for calculating the interest rate of a loan which covers all costs and adequately compensates for the risks associated with a loan.

For bank internal purposes, it is important to split the interest rate into its components, i.e., which part of the interest rate reflects funding costs, which part expected losses, or which part basis swap hedging costs. For this reason, a RAROC scheme is derived step-by-step using the general valuation Formula (1). Before we start, we have to make an assumption on the disbursement of a loan’s notional. This is not reflected in the valuation equation (1). The assumption in this article is that a loan’s notional is disbursed on disbursement dates D_j and that on the date D_j the amount N_j^D is paid out to the borrower. The total notional N^D is the sum over all disbursements $N^D = \sum_{D_j} N_j^D$.

The first component of the proposed RAROC scheme is the base swap rate. It is only relevant for a fixed-rate loan. For a floating-rate loan, this component is zero. The base swap rate is the fixed-rate that has to be charged by a bank that leads to an identical present value as the stream of Ibor payments. This rate is needed as a reference point to make floating-rate and fixed-rate loans comparable. The base swap rate y_s at valuation time t is computed from

$$y_s = \frac{\sum_{t < T_i} N_i f_{i, \Lambda_i} \tau_i \delta(T_i)}{\sum_{t < T_i} N_i \tau_i \delta(T_i)} \tag{12}$$

Alternatively, y_s can be interpreted as the interest rate that has to be charged for fixed-rate loans to make assets equal to liabilities in a bank’s balance sheet under the assumption that all other costs and risks can be ignored. Using this as a starting point, we will add all other relevant cost components of a loan to y_s in the following steps. To simplify the notation, we will use the abbreviation

$$PV(t; N^D, \delta) = \sum_{D_j < t} N_j^D + \sum_{t < D_j} N_j^D \delta(D_j) \tag{13}$$

This is the sum of all parts of the total loan balance that are already paid out at time t and the present value of the loan parts that still have to be disbursed.

In the next step, funding costs are computed. This is a bit awkward because funding might be linked to a Ibor tenor that is different from the payment frequency of the loan. To separate funding costs from basis swap hedging costs, we have to use the discount curve δ_f and, if the loan is a floating rate loan, compute forward rates from the swap curve corresponding to the Ibor rate L_f . For a floating-rate loan, this leads to the condition

$$PV(t; N^D, \delta_f) = \sum_{T_i < t} A_i + \sum_{t < W_i} \hat{N}_i f_{i, \Lambda_f} \zeta_i \delta_f(W_i) + \sum_{t < T_i} (N_i s_f \tau_i + A_i) \delta_f(T_i) \tag{14}$$

where W_i are the payment times of the funding bonds in (6), \hat{N} is the average notional in an interest rate period and s_f is the spread over Ibor that has to be paid by a borrower to cover funding costs. To give an example for clarification, suppose $\Lambda_f = 6M$ and $\Lambda_l = 1M$. Since a loan might be amortizing, in each 6M period, the notional might change from month to month. Assuming that a repayment of the notional immediately leads to a reduction in the outstanding bonds for funding, the interest paid on the funding bonds has to be reduced with the amortizations. The mismatch in interest tenors is reflected in the averaging of the loan’s outstanding notional. If the mismatch is the other way round, i.e., $\Lambda_f < \Lambda_l$, this problem does not exist. Solving (14) for s_f gives

$$s_f = \frac{PV(t; N^D, \delta_f) - A_{past} - \sum_{t < W_i} \hat{N}_i f_{i, \Lambda_f} \zeta_i \delta_f(W_i) - A_{PV}}{\sum_{t < T_i} N_i \tau_i \delta_f(T_i)} \tag{15}$$

where we used the abbreviations $A_{past} = \sum_{T_i < t} A_i$ and $A_{PV} = \sum_{t < T_i} A_i \delta_f(T_i)$. For a fixed-rate loan, the solution can be derived from (15) by setting all forward rates f_{i, Λ_f} to zero and replacing s_f by the fixed-rate y_f . After solving for y_f the funding cost margin s_f can be computed as $s_f = y_f - y_s$.

When the payment frequencies of funding bonds Λ_f and the loan Λ_l are different, a basis swap is needed for hedging the mismatch in Ibor payments. These hedging costs can be computed from

(14) by replacing the discount curve δ_f with the loan's discount curve δ and going back to the loan's payment frequency. This leads to

$$PV(t; N^D, \delta) = A_{past} + \sum_{t < T_i} N_i f_{i,\Lambda_i} \tau_i \delta(T_i) + \sum_{t < T_i} (N_i s_{b,f} \tau_i + A_i) \delta_f(T_i), \tag{16}$$

where $s_{b,f}$ is the interest margin covering both funding and swap costs. Solving (16) leads to

$$s_{b,f} = \frac{PV(t; N^D, \delta) - A_{past} - \sum_{t < T_i} N_i f_{i,\Lambda_i} \tau_i \delta(T_i) - A_{PV}}{\sum_{t < T_i} N_i \tau_i \delta(T_i)} \tag{17}$$

from which the margin for hedging costs s_b can be computed as $s_b = s_{b,f} - s_f$. Again, the case of a fixed-rate loan is covered by setting $f_{i,\Lambda_i} = 0$ and replacing $s_{b,f}$ by the fixed rate $y_{b,f}$. The margin s_b associated with basis swap costs is computed as $s_b = y_{b,f} - y_f$.

So far, we have considered cost components that are independent of a loan's default risk. The next step is taking default risk into account. To derive a margin s_{EL} reflecting expected loss risk, the condition expected assets equals liabilities is applied. We use the abbreviations

$$V_D(t) = \sum_{t < T_i} N_i R_i \delta(T_i) (v(T_{i-1}^*) - v(T_i)) \tag{18}$$

and

$$PV(t; N^D, \delta, v) = \sum_{D_j < t} N_j^D + \sum_{t < D_j} N_j^D v(D_j) \delta(D_j) \tag{19}$$

In (19), the survival probabilities reflect the fact that a bank will only pay out future tranches of a loan when the borrower is still alive. Using these abbreviations and (1), the interest rate spread $s_{EL,b,f}$ containing expected loss risk and the already computed funding and hedging costs is computed from the condition

$$PV(t; N^D, \delta, v) = A_{past} + \sum_{t < T_i} (N_i (f_{i,\Lambda_i} + s_{EL,b,f}) \tau_i + A_i) \delta(T_i) v(T_i) + V_D(t), \tag{20}$$

where again the special case of a fixed-rate loan is included by setting $f_{i,\Lambda_i} = 0$ and replacing $s_{EL,b,f}$ by a fixed-rate $y_{EL,b,f}$. Solving (20) for $s_{EL,b,f}$ gives

$$s_{EL,b,f} = \frac{PV(t; N^D, \delta, v) - A_{past} - \sum_{t < T_i} (N_i f_{i,\Lambda_i} \tau_i + A_i) \delta(T_i) v(T_i) - V_D(t)}{\sum_{t < T_i} N_i \tau_i \delta(T_i) v(T_i)} \tag{21}$$

The expected loss margin s_{EL} is computed as $s_{EL,b,f} - s_{b,f}$ for the floating-rate loan and as $y_{EL,b,f} - y_{b,f}$ for the fixed-rate loan.

When calculating s_f , s_b , and s_{EL} the interest margins were motivated from balance sheet considerations. In all the calculation steps, the assets of a bank and its liabilities were matched exactly or in expectation depending on the assumptions in each step. If default risks were independent, the calculations would be finished at this step because, by the law of large numbers, the variance in a loan portfolio's losses will become arbitrarily small if the number of loans is sufficiently large and without any volume concentration. This would result in deterministically matched assets and liabilities. Credit risks, however, are not independent since all borrowers are affected by macroeconomic risk resulting in dependent defaults. In a bad macroeconomic environment, credit losses are higher than expected, while in a benign scenario, they are lower. To avoid bankruptcy in recession years, banks have to hold an equity capital buffer than could absorb losses beyond expectation.

There are minimum requirements on the size of the capital buffer from regulators in [Basel Committee on Banking Supervision \(2006, 2011\)](#). For less sophisticated banks, a simple approach using fixed weights like 8% of outstanding loan balance are applied in the standardized Approach. Here, the

calculation of the capital buffer E is simple and E is independent of credit risk parameters like PD and LGD. Most of the internationally active banks, however, apply the Internal Ratings Based Approach which allows banks to compute minimum capital buffers from internal estimates of PD and LGD using the formula

$$E = N LGD \left(\Phi \left(\frac{\Phi^{-1}(PD) + \sqrt{\rho} \Phi^{-1}(0.999)}{\sqrt{1-\rho}} \right) - PD \right), \quad (22)$$

where $PD = 1 - v(1)$ is the one-year default probability of the borrower, LGD can be computed from the collateralization at the loan's start, and ρ is the asset correlation which is defined in [Basel Committee on Banking Supervision \(2006\)](#) depending on the borrower segment.³ As already outlined in Section 2, using regulatory capital for performance measurement becomes increasingly more popular in banking practice due to tightened capital requirements. However, the scheme would also work for E derived from a more complex credit portfolio model.

The capital E is allocated to the loan and cannot be used for other investments. A bank defines a target return w_t on its equity capital. As already outlined in Section 2 this could be done by some modeling approach or by expert decision. The equity capital E is not lying in a safe but invested in assets like government bonds where it generates a return w_r . The difference between w_t and w_r has to be generated by the interest income of the loan. This leads to an additional interest rate margin s_{UL} , the unexpected loss margin, which is computed as

$$s_{UL} = (w_t - w_r) \frac{E}{ND}. \quad (23)$$

Finally, the operating costs of a bank, like staff salaries or office costs, have to be covered by a loan's interest income. These costs are summarized in an additional cost margin c . The calculation of c depends on the institutional details of a bank, and there is no general rule that is applicable to any bank. To include these costs into RAROC an adjustment is required reflecting the fact that only surviving borrowers can cover the costs. This leads to a cost margin s_c which is computed as

$$s_c = c \frac{\sum_{t < T_i} N_i \tau_i \delta_i(T_i)}{\sum_{t < T_i} N_i \tau_i \delta_i(T_i) v(T_i)} \quad (24)$$

Note, that this assumption is not required for economic capital. The reason is that by construction the expected loss margin s_{EL} should be sufficient to cover expected loss and economic capital is only a buffer against unexpected events. Once a borrower defaults and a loss provision is built, the capital is freed and can be used for other investments of the bank.

Putting all cost components together gives the hurdle rate z_h of a loan, i.e., the interest rate that covers all costs and profitability targets of a bank. It is computed as

$$z_h = y_s + s_f + s_b + s_{EL} + s_{UL} + s_c. \quad (25)$$

Note, that this calculation is true only if the PD of a borrower does not depend on the interest rate z . If this is not the case (25) has to be replaced by a numerical algorithm as discussed in the following two sections.

If the interest rate z is given, the return on equity capital, or, equivalently, a loan's RAROC can be computed as

$$\text{RAROC} = \frac{z - y_s - s_f - s_b - s_{EL} - s_c}{E/ND} + w_r. \quad (26)$$

³ Note that for calculating E under Basel II, a different set of PD and LGD is applied than for expected loss calculations. For regulatory purposes, PD is a long-term average reflecting average default risk over an economic cycle while LGD is computed under worst-case assumptions. We do not go into these details here since the precise calculation of E does not affect the structure of the RAROC scheme.

This equation allows a bank to measure the impact of interest rates different from the hurdle rate z_h on the return on economic capital. Furthermore, (26) can be used to measure the performance of already existing loans.

5. Properties of RAROC

When looking at (26) it seems that if z becomes arbitrarily large, so does RAROC. This means that this performance measure suggests that banks should charge as high as possible interest rates to maximize profitability. Obviously, this reasoning is flawed since, at a certain interest rate level, a borrower is unable to service his debt and will default. In order to make RAROC realistic, we have to link default probabilities and interest rates.

When building internal models for the default risk of a borrower, banks often include a variable known as the debt service ratio (DSR) into the list of explanatory risk factors. DSR computes the ratio of annual interest and amortization payments on all loans of a borrower and the available funds to pay interest. In the case of a company, these funds are net profit before interest and taxes. In the case of a retail client, it is net annual income. The interest rate z of a loan enters DSR linearly as $DSR = \beta_0 + z \cdot \beta_1$. The coefficient β_0 contains payments on other existing credit products a borrower might have, while β_1 is the ratio of the loan’s balance divided by available funds. If β_1 is small, then PD can be approximately considered as independent of z . The larger β_1 , however, the more this approximation leads to wrong conclusions.

To analyze the properties of RAROC when default risk and interest rates are coupled, we use a simplified setup to maintain analytical tractability. We assume a bullet loan with a balance of one that pays interest annually at times $T_i = 1, \dots, m$ and $t = 0$. Furthermore, we assume funding costs, hedging costs and operational costs of a bank are zero. In addition, we assume the interbank curve is flat, and all zero rates are zero, i.e., all discount factors are equal to one. Finally, we assume w_r equals zero and R_i is a constant R . Concerning economic capital, we assume that a bank follows the Basel Standardized Approach, i.e., that economic capital E is independent of PD. This leads to a simplified RAROC formula

$$RAROC = \frac{z - s_{EL}}{E}, \tag{27}$$

with a simplified s_{EL} as

$$s_{EL} = \frac{(1 - R) \cdot (1 - v(m))}{\sum_{i=1}^m v(i)}. \tag{28}$$

For the latter equation, note that in (21) A_i is zero for all $i < m$ for a bullet loan and one for $i = m$. The default part V_D simplifies because R_i is constant and discount factors are one which results in a telescoping sum that can be simplified to $1 - v(m)$.

To model survival probabilities, we assume DSR is part of the risk factors in (10) and we condense all other risk factors into the constant β_0 . Furthermore, we assume a constant h . This leads to the survival probability $v(i)$ at time i of

$$\begin{aligned} v(i) &= \exp\left(-\exp(\beta_0 + z \cdot \beta_1) \cdot \int_0^i h \, ds\right) \\ &= \exp(-\exp(\beta_0 + z \cdot \beta_1) \cdot hi) \\ &= \exp(-\exp(\beta_0 + z \cdot \beta_1))^{hi} = q^{hi}, \end{aligned} \tag{29}$$

$$q := \exp(-\exp(\beta_0 + z \cdot \beta_1)). \tag{30}$$

The properties of RAROC under these assumptions are summarized in Theorem 1.

Theorem 1. Under the assumptions of (27)–(29) where the constants β_1, h and R are required to fulfill $\beta_1 > 0, h > 0$, and $0 < R < 1$, $RAROC(z)$ as a function of the loan interest rate z has the properties:

1. $\lim_{z \rightarrow -\infty} RAROC(z) = -\infty$

2. $\lim_{z \rightarrow +\infty} RAROC(z) = -\infty$
3. There exists a unique interest rate z_{\max} with $RAROC(z) \leq RAROC(z_{\max}), \forall z \in \mathbb{R}$

The proof of Theorem 1 is provided in the Appendix A. The economic interpretation of Theorem 1 is quite intuitive. The first relation means that if a bank pays huge interest until the verge of bankruptcy, RAROC becomes arbitrarily small. If, on the other hand, the borrower pays huge interest which brings him close to bankruptcy, RAROC becomes arbitrarily small, too. Therefore, if a loan brings either the borrower or the bank into trouble, this is adequately reflected by RAROC. Somewhere in between these extreme cases, there is an optimum from the perspective of the bank which allows the bank to generate high income while keeping default risk manageable if the client is creditworthy.

Theorem 1 has direct consequences on the loan origination process of a bank. There exists only a finite range of interest rates that should be considered as acceptable from a bank’s perspective. Given the profitability target of a bank w_t only loans should be accepted with a RAROC greater or equal w_t . This translates directly into a set of acceptable interest rates which we call the profitability range.

Theorem 2. Define the profitability range P for a loan as the set of interest rates leading to a RAROC greater or equal w_t

$$P = \{z : RAROC(z) \geq w_t\}. \tag{31}$$

Then exactly one of the three cases is true:

1. P is empty
2. P consists of one point z_{\max}
3. P consist of an interval $[z_h, z_{\max}]$

The proof of Theorem 2 follows directly from Theorem 1. In the case of $RAROC(z_{\max}) < w_t$, P is empty and if $RAROC(z_{\max}) = w_t$ then $P = \{z_{\max}\}$. Finally, if $RAROC(z_{\max}) > w_t$, there exists an interval $[z_l, z_u]$ where $RAROC(z) \geq w_t$. The lowest interest rate of this interval is the hurdle rate z_h which is the minimum interest rate that covers all costs and risks associated with the loan. Note, when PD is a function of z , the hurdle rate can no longer be determined by (25) but has to be computed by a numerical algorithm finding $\min_z RAROC(z) \geq w_t$. Although there exists interest rates z with $z > z_{\max}$ and $RAROC(z) > w_t$ it does not make sense for a bank to charge them. It can achieve the same profitability at a lower interest rate making it more likely that the client will accept the offer from the bank and not from a competitor.

To conclude this Section, we remark that we suppose that Theorem 1 holds in more general setup. In numerical examples, when using (22) for calculating economic capital E we still get a unique maximum RAROC in numerical examples. While it is quite easy to show that Parts 1 and 2 of Theorem 1 still hold, the third part becomes rather complex since the most general Basel formula includes PD as a function of z and the asset correlation ρ as a function of PD and, therefore, as a function of z which makes the analytical treatment of RAROC in this case rather difficult. Yet from our numerical experiments, we suppose that Theorem 1 holds in the more general setup.

6. Numerical Example

To illustrate the RAROC pricing scheme, we consider fixed-rate loans with or without amortization, and with or without collateralization. We consider a ten-year fixed-rate loan paying an interest rate of 4% with quarterly interest payments. The loan’s notional is $N = 1,000,000$ which is paid in one tranche at the loan’s start date. We consider a bullet loan, i.e., a loan without amortization payments and an installment loan with an amortization rate of 5% annually. This means that in addition to the interest payment, the installment loan pays back 1.25% of the initial notional, i.e., $A_i = 12,500$ every quarter. Furthermore, the impact of collateral is illustrated. We assume that in this

case, collateral with a cash equivalent value of $C = 600,000$ is available. For the unsecured parts of the loan, we assume a recovery rate $R^u = 20\%$. This leads to a total of four different loans. For these loans RAROC is computed in the first part and hurdle rates and maximum RAROC in the second part.

To carry out these calculations, information about interest rate markets and institutional details of the bank is required. In the first step, the information on funding and interest rate markets is collected. We assume that the funding of a bank is expressed as a spread over 12M Ibor rates, i.e., the bank funds itself by issuing bonds paying annual interest linked to a 12M Ibor rate. Furthermore, swap rates of fixed-to-floating swaps and basis swaps have to be included to account for the tenor mismatch in funding and lending. Assuming the European conventions, we have quotes for swaps exchanging a fixed-rate against a 6M Ibor rate. Furthermore, we need the spreads of basis swaps exchanging a 6 M Ibor rate against a 12M Ibor rate because of the funding tenor $\Lambda_f = 12M$, and we need the spreads of basis swaps exchanging a 3M Ibor rate against a 6M Ibor rate because of the loan’s tenor $\Lambda_l = 3M$. The data is summarized in Table 1.

Table 1. Quotes of fixed-to-floating swaps, 3M Ibor against 6M Ibor basis swaps, 6M Ibor against 12M Ibor basis swaps, and funding spreads. All quotes are in percent.

Tenor	Swap Rate	3M→6M Spread	6M→12M Spread	Funding Spread
3M	0.05			
6M	0.15			
1Y	0.22	0.10	0.08	0.10
2Y	0.45	0.10	0.08	0.12
3Y	0.58	0.10	0.08	0.14
4Y	0.75	0.10	0.08	0.17
5Y	0.95	0.10	0.08	0.20
6Y	1.13	0.10	0.08	0.22
7Y	1.30	0.10	0.08	0.25
8Y	1.47	0.10	0.08	0.28
9Y	1.62	0.10	0.08	0.30
10Y	1.76	0.10	0.08	0.33
12Y	1.96	0.10	0.08	0.40
15Y	2.12	0.10	0.08	0.50

The front part of the discount curves that is bootstrapped from fixed-to-floating swaps is built from deposit rates. In the example of Table 1 the 3M and 6M deposit rate are used for computing the front part of $\delta_{M,6M}$. The data in Table 1 are not real market quotes but serves for illustration only.

For the evaluation of default risk, we assume that a bank has established a rating system with six grades and uses a Cox proportional hazard model (10) to estimate term-structures of default probabilities. We assume that the loan’s interest rate is part of one risk factor, all other risk factors are summarized in the coefficient β_0 and h is a constant as in (29). The parameters for each rating grade are summarized in Table 2 while the default probabilities for each rating grade are illustrated in Figure 1 using the interest rate of the example, 4%.

Table 2. Parameters for the Cox proportional hazard model for each rating grade.

Rating Grade	β_0	β_1	h
1	−6.0	10.0	1.0
2	−5.5	10.0	1.0
3	−5.0	10.0	1.0
4	−4.0	10.0	1.0
5	−3.5	10.0	1.0
6	−2.5	10.0	1.0

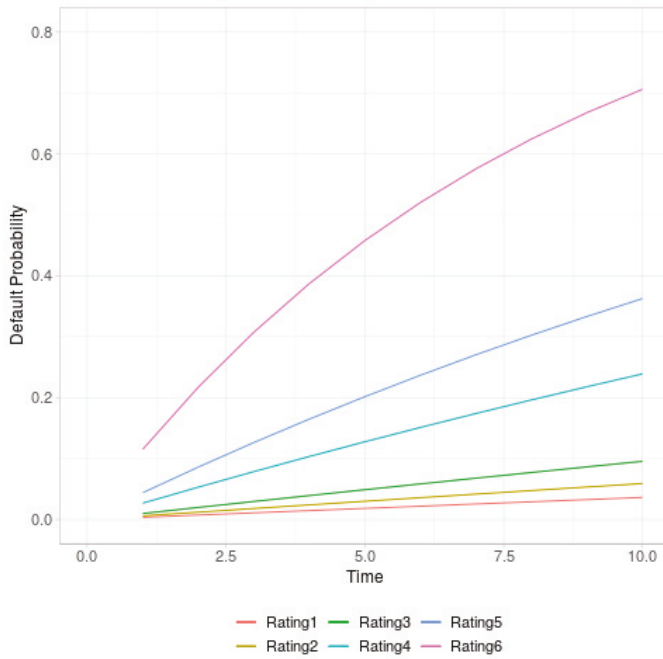

Figure 1. Term-structure of default probabilities for each rating grade.

It remains to define economic capital and the operating costs of the bank. We assume an annual operating cost margin $c = 0.50\%$. Economic capital is computed following the regulatory rules for corporate clients with an annual turnover above 50 million EUR where we use both the Standardized and the Internal Ratings Based Approach in our examples. In the case of the Standardized Approach, we assume that the company does not have an external rating. Finally, we assume a target RAROC w_t of 10%.

Cost components and RAROC are computed for the collateralized bullet loan (Loan I), the unsecured bullet loan (Loan II), the collateralized installment loan (Loan III), and the unsecured installment loan (Loan IV). The borrower rating is “3”, i.e., we assume a borrower with a one-year default probability of roughly 1%. The results are summarized in Table 3 when E is computed as $0.08 \cdot N^D$ and in Table 4 when E is computed by (22).

Table 3. Cost components RAROC for the four example loans assuming rating grade 3 and using the Standardized Approach for computing E . All results are percentage values.

Quantity	Loan I	Loan II	Loan III	Loan IV
y_s	1.63	1.63	1.45	1.45
s_f	0.33	0.33	0.30	0.30
s_b	0.18	0.18	0.18	0.18
s_{EL}	0.29	0.78	0.16	0.78
s_c	0.52	0.52	0.52	0.52
E	8.00	8.00	8.00	8.00
RAROC	12.94	6.88	17.28	9.51

Table 4. Cost components RAROC for the four example loans assuming rating grade 3 and using the Internal Ratings Based Approach for computing E . All results are percentage values.

Quantity	Loan I	Loan II	Loan III	Loan IV
y_s	1.63	1.63	1.45	1.45
s_f	0.33	0.33	0.30	0.30
s_b	0.18	0.18	0.18	0.18
s_{EL}	0.29	0.78	0.16	0.78
s_c	0.52	0.52	0.52	0.52
E	7.27	18.17	7.27	18.17
RAROC	13.83	2.94	18.48	4.07

The quantities y_s and s_f show the effect of the amortization rate. Both the swap curve and the funding spreads curve are steep. Since an amortization rate reduces the effective maturity of a loan both quantities are lower for amortizing loans. This effect is not seen in s_b because both basis swap spread curves are flat. The expected loss margin s_{EL} is considerably higher for the unsecured loan. For the amortizing collateralized loan, the expected loss margin is lowest because this loan becomes less risky when the outstanding balance is reduced due to the amortizations. This effect is not seen in E in Table 4 because economic capital is based on a one-year horizon in the Basel II setup. We see that in both tables, only the collateralized loans pass the RAROC target of 10%. The unsecured loans show a RAROC below 10% and should be rejected if a bank strictly sticks to its profitability target.

In the second example, we compute z_h, z_{max} and maximum RAROC for Loan IV. Again we present the results for both regulatory regimes. The outcome for the Standardized Approach is displayed in Table 5 while the numbers for the Internal Ratings Based Approach are shown in Table 6.

Table 5. Hurdle rate, maximum RAROC and z_{max} for the unsecured installment loan Loan IV under the Standardized Approach. All results are percentage values.

Rating Grade	z_h	z_{max}	RAROC _{max}
1	3.52	38.84	332.62
2	3.71	33.84	270.12
3	4.05	28.84	207.62
4	5.88	18.84	82.62
5	9.60	13.84	20.12
6	NA	3.84	-104.88

Table 6. Hurdle rate, maximum RAROC and z_{max} for the unsecured installment loan Loan IV under the Internal Ratings Based Approach. All results are percentage values.

Rating Grade	z_h	z_{max}	RAROC _{max}
1	4.06	29.86	87.63
2	4.59	26.40	69.34
3	5.29	23.09	51.85
4	8.44	16.78	19.55
5	NA	13.39	4.66
6	NA	5.69	-23.49

We see that for the high-risk clients, no hurdle rate z_h exists. This means that it is not possible for a bank to set an interest rate that makes the loan profitable. Therefore, a loan application of these clients should be rejected. We see that for Rating “3” in both cases, the hurdle rate is above 4%. This is consistent with the results in Tables 3 and 4 where RAROC was below the profitability target of 10% for Loan IV when an interest rate of 4% was used. Consistent with intuition, in both cases z_h is increasing with borrower default risk while z_{max} and RAROC_{max} are decreasing.

7. Discussion

In this article, a loan pricing scheme is developed using the performance measure RAROC. Motivated by balance sheet considerations, i.e., the desire to match assets and liabilities, a calculation scheme is proposed which explicitly decomposes a loan's interest rate into relevant cost components: Funding costs, costs for hedging interest rate risks, expected loss costs, target return on economic capital, and internal bank costs. For fixed-rate loans, a formula for the base swap rate was given in addition. These cost components are essential for internal fund transfer pricing processes between separate functions in a bank.

The proposed pricing scheme is applicable for loans with the deterministic interest rate, i.e., fixed-rate loans and floating-rate loans linked to Ibor rates. We have analyzed the scheme mainly for the case where term-structures of default probabilities are estimated using a Cox proportional hazard model. This was motivated by the analytical tractability of this model. However, the scheme does not depend on this modeling assumption and could work with any term-structure of default probabilities regardless of its determination.

In a theoretical analysis, it was shown in a slightly simplified setup that if a borrower's default probability increases with a loan's interest rate then RAROC becomes $-\infty$ in the limiting cases of arbitrarily large negative and positive interest rates which means that both the cases of bank and borrower bankruptcy are treated within economic intuition by RAROC. It was further shown that RAROC has a unique maximum and that at most a finite interval of interest rates exists at which a bank should accept a loan application. In cases where interest rates a borrower is willing to accept are outside this interval or when the acceptance range is empty, a bank should reject a loan application.

Numerical examples illustrated the application of this loan pricing framework. The examples suggest that the main results of the article hold in a more general setup than we were able to prove formally. The main challenge of applying this framework in practice is finding a link between a loan's interest rate and borrower default rates empirically. In real data sets important information for determining this relationship like the total interest a borrower is paying on all his existing loan products or timely income information is often missing in retail data sets which makes the parameters β_0 and β_1 of our examples very hard to estimate.

The benefits of implementing this approach in practice are threefold. First, the scheme delivers a split of a loan's interest rate into cost components for internal fund transfer pricing. Second, when interest rate costs are properly included in a credit scorecard, the scheme allows the calculation of the profitability range for a loan. Only rates within this range a bank should offer when originating a loan. Finally, since the scheme delivers a loan valuation, it could, in addition, be valuable in the price determination of loan portfolio transactions when loans are sold to investors.

One shortcoming of the profitability range is that this interest rate interval models only the perspective of the bank. These are the interest rates that ensure that the profitability requirements of the bank are met, but there is no view from the borrower's perspective included. It would be very helpful if a bank would have, in addition to the profitability range, some information about the likelihood that a borrower will accept a loan offer and how this likelihood changes within the profitability range. [Chun and Lejeune \(2020\)](#) use the probability that a borrower accepts a loan offer in their model but merely on a theoretical basis using several distribution functions without giving any suggestion on empirical verification. Complementing the profitability range by including the borrower perspective would further increase the value of the RAROC scheme. We leave this challenging task for future research.

Author Contributions: Conceptualization, B.E. and H.P.; methodology, B.E.; validation, B.E. and H.P.; writing—original draft preparation, B.E.; writing—review and editing, H.P.; supervision, H.P.; project administration, H.P.; funding acquisition, H.P. All authors have read and agreed to the published version of the manuscript.

Funding: This research was funded by the Ministry of Education and Training in Vietnam, Ho Chi Minh City Open University and Open Source Investor Services B.V. grant number B2019-MBS-03.

Conflicts of Interest: The authors declare no conflict of interest. The funders had no role in the design of the study; in the collection, analyses, or interpretation of data; in the writing of the manuscript, or in the decision to publish the results.

Abbreviations

The following abbreviations are used in this manuscript:

- CAPM capital asset pricing model
- CDS credit default swap
- LGD loss given default
- PD default probability
- RAROC risk-adjusted return on capital

Appendix A. Proof of Theorem 1

Theorem 1 consists of three parts which we each proof in a separate step. We start with the proof of 1. For the survival probabilities v_i , it is easy to see that $\lim_{z \rightarrow -\infty} v(i) = 1$. This means that $\lim_{z \rightarrow -\infty} z_{EL} = 0$ and $\lim_{z \rightarrow -\infty} (z - z_{EL})/E = -\infty$.

The proof of Part 2 is a bit more evolved. We have to show that $\lim_{z \rightarrow +\infty} z - z_{EL} = -\infty$. From (29) we see that $\lim_{z \rightarrow +\infty} v(i) = 0$. Therefore, $\lim_{z \rightarrow +\infty} z_{EL} = +\infty$ and $\lim_{z \rightarrow +\infty} z = +\infty$ which makes it not obvious to see how RAROC will behave in the limit. A reformulation of $z - z_{EL}$ leads to

$$z - z_{EL} = z - \frac{(1 - R)(1 - v(m))}{\sum_{i=1}^m v(i)} = \frac{z \sum_{i=1}^m v(i) - (1 - R)(1 - v(m))}{\sum_{i=1}^m v(i)}$$

For each product $zv(i)$, we can show that $\lim_{z \rightarrow +\infty} zv(i) = 0$:

$$\begin{aligned} \lim_{z \rightarrow +\infty} zv(i) &= \lim_{z \rightarrow +\infty} zq^{hi} = \lim_{z \rightarrow +\infty} \frac{z}{q^{-hi}} = \lim_{z \rightarrow +\infty} \frac{1}{-hi \cdot q^{-hi-1} \cdot q \log(q)\beta_1} \\ &= \lim_{z \rightarrow +\infty} -\frac{q^{hi}}{hi \cdot \log(q)\beta_1} = 0. \end{aligned}$$

At the third equality sign we have used the rule of L'Hospital and the derivative of q with respect to z

$$\frac{dq}{dz} = \frac{d}{dz} \exp(-\exp(\beta_0 + z\beta_1)) = -\exp(-\exp(\beta_0 + z\beta_1)) \exp(\beta_0 + z\beta_1)\beta_1 = q \log(q)\beta_1.$$

This results allows us to compute (we use a bit sloppy notation in the end)

$$\lim_{z \rightarrow +\infty} z - z_{EL} = \lim_{z \rightarrow +\infty} \frac{z \sum_{i=1}^m v(i) - (1 - R)(1 - v(m))}{\sum_{i=1}^m v(i)} = \frac{0 - (1 - R)}{0} = -\infty.$$

For the proof of Part 3, we will show that the first derivative of RAROC with respect to z is between 1 and $-\infty$ and it is monotonically decreasing which implies that there exists exactly one root of $dRAROC(z)/dz$ which proofs the Theorem. We start with $dRAROC(z)/dz$ where we use the abbreviations $L := 1 - R$ and $D := z - z_{EL}$:

$$\begin{aligned} \frac{dD}{dz} &= 1 - \frac{d}{dz} \frac{L(1 - q^{hm})}{\sum_{i=1}^m q^{hi}} \\ &= 1 - L \frac{-\sum_{i=1}^m q^{hi} \cdot hm \cdot q^{hm-1} \frac{dq(z)}{dz} - (1 - q^{hm}) \sum_{i=1}^m hi \cdot q^{hi-1} \frac{dq(z)}{dz}}{(\sum_{i=1}^m q^{hi})^2} \\ &= 1 + L \log(q)\beta_1 \frac{\sum_{i=1}^m q^{hi} hm \cdot q^{hm} + (1 - q^{hm}) \sum_{i=1}^m hi \cdot q^{hi}}{(\sum_{i=1}^m q^{hi})^2} \end{aligned}$$

$$= 1 + L \log(q) \beta_1 \frac{\sum_{i=1}^m hi \cdot q^{hi} + h(m-i)q^{h(i+m)}}{(\sum_{i=1}^m q^{hi})^2}$$

We have $\lim_{z \rightarrow -\infty} q(z) = 1$ and, therefore, $\lim_{z \rightarrow -\infty} \frac{d(z-z_{EL})}{dz} = 1$. On the other end, we have $\lim_{z \rightarrow \infty} q(z) = 0$ which leads to $\lim_{z \rightarrow \infty} \frac{d(z-z_{EL})}{dz} = -\infty$. The reason for the latter is that $\lim_{z \rightarrow \infty} \log(q) = -\infty$ and

$$\lim_{q \rightarrow 0} \frac{\sum_{i=1}^m hi \cdot q^{hi} + h(m-i)q^{h(i+m)}}{(\sum_{i=1}^m q^{hi})^2} = +\infty,$$

which can be seen after applying the rule of L'Hospital $2m - 1$ times. Note that the highest exponent of q in the numerator is $2m - 1$ because the coefficient of q^{2m} is zero and the highest exponent of the denominator is $2m$. This leaves one q in the denominator after $2m - 1$ times applying L'Hospital's rule while there is none in the numerator.

Since $\frac{d(z-z_{EL})}{dz}$ is continuous, it must have at least one root. To show that this root is unique, we show that $\frac{d(z-z_{EL})}{dz}$ is decreasing monotonically by proving that $\frac{d^2D}{dz^2} = \frac{d^2(z-z_{EL})}{dz^2}$ is negative for all z .

$$\begin{aligned} \frac{d^2D}{dz^2} &= L\beta_1 \frac{1}{q} \frac{dq}{dz} \frac{\sum_{i=1}^m hi \cdot q^{hi} + h(m-i)q^{h(i+m)}}{(\sum_{i=1}^m q^{hi})^2} \\ &+ L \log(q) \beta_1 \frac{\left(\sum_{i=1}^m q^{hi}\right)^2 \left(\sum_{i=1}^m h^2 i^2 \cdot q^{hi-1} + h^2(m^2 - i^2)q^{h(i+m)-1}\right)}{\left(\sum_{i=1}^m q^{hi}\right)^4} \frac{dq}{dz} \\ &- L \log(q) \beta_1 \frac{2 \left(\sum_{i=1}^m q^{hi}\right) \cdot \left(\sum_{i=1}^m hi \cdot q^{hi-1}\right) \cdot \left(\sum_{i=1}^m hi \cdot q^{hi} + h(m-i)q^{h(i+m)}\right)}{\left(\sum_{i=1}^m q^{hi}\right)^4} \frac{dq}{dz} \\ &= L\beta_1^2 \log(q) \frac{\sum_{i=1}^m hi \cdot q^{hi} + h(m-i)q^{h(i+m)}}{\left(\sum_{i=1}^m q^{hi}\right)^2} \\ &+ L \log(q)^2 \beta_1^2 \frac{\left(\sum_{i=1}^m q^{hi}\right) \left(\sum_{i=1}^m h^2 i^2 \cdot q^{hi} + h^2(m^2 - i^2)q^{h(i+m)}\right)}{\left(\sum_{i=1}^m q^{hi}\right)^3} \\ &- L \log(q)^2 \beta_1^2 \frac{2 \cdot \left(\sum_{i=1}^m hi \cdot q^{hi}\right) \cdot \left(\sum_{i=1}^m hi \cdot q^{hi} + h(m-i)q^{h(i+m)}\right)}{\left(\sum_{i=1}^m q^{hi}\right)^3} \\ &= L\beta_1^2 \log(q) \frac{\sum_{i=1}^m hi \cdot q^{hi} + h(m-i) \cdot q^{h(i+m)}}{\left(\sum_{i=1}^m q^{hi}\right)^2} \\ &+ L \log(q)^2 \beta_1^2 \frac{\sum_{i,j=1}^m q^{hj} \left(h^2 i^2 \cdot q^{hi} + h^2(m^2 - i^2) \cdot q^{h(i+m)}\right)}{\left(\sum_{i=1}^m q^{hi}\right)^3} \\ &- L \log(q)^2 \beta_1^2 \frac{2 \cdot \sum_{i,j=1}^m hj \cdot q^{hj} \cdot \left(hi \cdot q^{hi} + h(m-i) \cdot q^{h(i+m)}\right)}{\left(\sum_{i=1}^m q^{hi}\right)^3} \\ &= L\beta_1^2 \log(q) \frac{\sum_{i=1}^m hi \cdot q^{hi} + h(m-i) \cdot q^{h(i+m)}}{\left(\sum_{i=1}^m q^{hi}\right)^2} \\ &- L \log(q)^2 \beta_1^2 \frac{\sum_{i,j=1}^m h^2(2ij - i^2) \cdot q^{h(i+j)} + h^2(2j(m-i) - m^2 + i^2) \cdot q^{h(i+j+m)}}{\left(\sum_{i=1}^m q^{hi}\right)^3} \end{aligned}$$

Since $\log(q) < 0$ the first term of this expression is negative. To prove that the full expression is negative, it is sufficient to prove that each coefficient of q^{hi} in the numerator of the second term is non-negative and at least one is strictly positive. In total there are $3m - 1$ terms q^{hk} with $k = 2, \dots, 3m$.

For $k = 2, \dots, m + 1$ only the first part of the double sum is relevant, from $k = m + 2, \dots, 2m$ both parts contribute, while from $k = 2m + 1, \dots, 3m$ only the last part counts.

We start with $k = 2, \dots, m + 1$. For fixed k , the index i can run from 1 to $k - 1$ while j is set to $k - i$. Then $i + j = k$ and all possible combinations leading to $i + j = k$ are covered. Summing over the coefficients that contribute to q^{hk} yields

$$\sum_{i=1}^{k-1} 2(i(k-i)) - i^2 = \sum_{i=1}^{k-1} 2ki - 3i^2$$

Using the relations $\sum_{i=1}^k i = \frac{k(k+1)}{2}$ and $\sum_{i=1}^k i^2 = \frac{k(k+1)(2k+1)}{6}$ leads to

$$\sum_{i=1}^{k-1} 2ki - 3i^2 = 2k \frac{(k-1)k}{2} - 3 \frac{(k-1)k(2k-1)}{6} = \frac{k(k-1)}{2} > 0.$$

Next, we look at $k = m + 2, \dots, 2m$. We parametrize this as $m + k, k = 2, \dots, m$. In this case we have contributions from both terms of the double sum and the coefficient of q^{m+k} is computed as

$$\sum_{i=k}^m (2i(m+k-i) - i^2) + \sum_{i=1}^{k-1} (2(k-i)(m-i) - m^2 + i^2) = \frac{1}{2}(m^2 - m) + k(m - k + 1) > 0.$$

The derivation of the above result is a bit lengthier as in the first case but uses the same reasoning.

Finally, we report the result for $k = 2m + 1, \dots, 3m$. Similar as before, we run k from 1 to m and ensure that $i + j = 2m + k$. Summing over all combinations of i and j fulfilling this condition leads to

$$\sum_{i=k}^m (2(m-i+k)(m-i) - m^2 - i^2) = \frac{1}{2}(m^2 + k^2) - km + \frac{1}{2}(m-k) \geq 0.$$

Here, the sum can become zero in the case of $k = m$. In all other cases, it is strictly positive. This concludes the proof that the second derivative of RAROC is always strictly negative.

References

- Aguais, Scott D., Larry Forest, Suresh Krishnamoorthy, and Tim Mueller. 1998. Creating value from both loan structure and price. *Commercial Lending Review* 13: 13–25.
- Aguais, Scott D., and Lawrence R. Forest. 2000. The future of risk-adjusted credit pricing in financial institutions. *RMA Journal* 83: 26–31.
- Aguais, Scott D., and Anthony M. Santomero. 1998. Incorporating new fixed income approaches into commercial loan valuation. *Journal of Lending & Credit Risk Management* 58–65. [CrossRef]
- Akhtar, Yasmeen, Kayani Mujtaba, and Tahir Yousaf. 2019. The effects of regulatory capital requirements and ownership structure on bank lending in emerging asian markets. *Journal of Risk and Financial Management* 12: 142. doi:10.3390/jrfm12030142. [CrossRef]
- Balog, Dora, Tamas Batyi, Peter Csoka, and Miklos Pinter. 2017. Properties and comparison of risk capital allocation methods. *European Journal of Operational Research* 259: 614–25. [CrossRef]
- Banasik, John, Jonathan N. Crook, and Lyn C. Thomas. 1999. Not if but when will borrowers default. *Journal of the Operational Research Society* 50: 1185–190. [CrossRef]
- Basel Committee on Banking Supervision. 2006. International Convergence of Capital Measurement and Capital Standards: A Revised Framework. Available online: <http://www.bis.org/publ/bcbsca.htm> (accessed on 30 March 2019).
- Basel Committee on Banking Supervision. 2011. Basel III: A Global Regulatory Framework for More Resilient Banks And Banking Systems. Available online: <http://www.bis.org/publ/bcbs189.htm> (accessed on 30 March 2019).
- Baule, Rainer. 2014. Allocation of risk capital on an internal market. *European Journal of Operational Research* 234: 186–96. [CrossRef]

- Buch, Arne, Gregor Dorfleitner, and Maximilian Wimmer. 2011. Risk capital allocation for rorac optimization. *Journal of Banking & Finance* 35: 3001–9.
- Choi, Yong S., Hitesh Doshi, Kris Jacob, and Stuart M. Turnbull. 2020. Pricing structured products with economic covariates. *Journal of Financial Economics* 135: 754–73. [CrossRef]
- Chun, So Yeon and Miguel A. Lejeune. 2020. Risk-based loan pricing: Portfolio optimization approach with marginal risk contribution. *Management Science*. [CrossRef]
- Crook, Jonathan and Tony Bellotti. 2010. Time varying and dynamic models for default risk in consumer loans. *Journal of the Royal Statistical Society: Series A (Statistics in Society)* 173: 283–305. [CrossRef]
- Crouhy, Michel, Stuart M. Turnbull, and Lee M. Wakeman. 1999. Measuring risk-adjusted performance. *Journal of Risk* 2: 5–36. [CrossRef]
- CSFB. 1997. *Creditrisk+ : A Credit Risk Management Framework*. Working Paper. Zurich: Credit Suisse.
- Dewasurendra, Sagara, Pedro Judice, and Qiji Zhu. 2019. The optimum leverage level of the banking sector. *Risk* 7: 51. [CrossRef]
- Engelmann, Bernd and Robert Rauhmeier. 2006. *The Basel II Risk Parameters: Estimation, Validation, and Stress Testing*. Berlin, Heidelberg and New York: Springer.
- European Central Bank. 2019. Financial Stability Review. May. Available online: <https://www.ecb.europa.eu/pub/pdf/fsr/ecb.fsr201905266e856634.en.pdf> (accessed on 25 May 2020).
- Greenbaum, Stuart I., George Kanatas, and Itzhak Venezia. 1989. Equilibrium loan pricing under the bank-client relationship. *Journal of Banking & Finance* 13: 221–35.
- Gupton, Greg M., Christopher C. Finger, and Mickey Bhatia. 1997. *Creditmetrics—Technical Document*. Technical Report. New York: Morgan Guaranty Trust Co. J.P.Morgan & Co.
- Ita, Andreas. 2016. Capital Allocation in Large Banks—A Renewed Look at Practice. Available online: <https://ssrn.com/abstract=2726165> (accessed on 25 May 2020)
- Jarrow, Robert A., David Lando, and Stuart M. Turnbull. 1997. A Markov model for the term structure of credit spreads. *Review of Financial Studies* 10: 481–523. [CrossRef]
- Kalkbrener, Michael. 2005. An axiomatic approach to capital allocation. *Mathematical Finance* 15: 425–37. [CrossRef]
- Kalkbrener, Michael, Hans Lotter, and Ludger Overbeck. 2004. Sensible and efficient capital allocation for credit portfolios. *Risk* 17: 19–24.
- Kang, Woo-Young, and Sunil Poshakwale. 2019. A new approach to optimal capital allocation for rorac maximization in banks. *Journal of Banking & Finance* 106: 153–65.
- Klaassen, Pieter, and Idzard Van Eeghen. 2018. Bank capital allocation and performance management under multiple capital constraints. *Journal of Risk Management in Financial Institutions* 11: 194–206. [CrossRef]
- Malik, Madhur, and Lyn C. Thomas. 2010. Modelling credit risk of portfolio of consumer loans. *Journal of the Operational Research Society* 61: 411–20. [CrossRef]
- Miu, Peter, Bogie Ozdemir, Evren Cubukgil, and Michael Giesinger. 2016. Determining hurdle rate and capital allocation in credit portfolio management. *Journal of financial services research* 50: 243–73. [CrossRef]
- Oino, Isaiah. 2018. Impact of regulatory capital on european banks financial performance: A review of post global financial crisis. *Research in International Business and Finance* 44: 309–1318. [CrossRef]
- Repullo, Rafael and Javier Suarez. 2004. Loan pricing under basel capital requirements. *Journal of Financial Intermediation* 13: 496–521. [CrossRef]
- Skoglund, Jimmy. 2017. Loan Fair Value Approaches Revisited. Available online: <https://ssrn.com/abstract=2902564> (accessed on 25 May 2020)
- Stoughton, Neal M., and Josef Zechner. 2007. Optimal capital allocation using roracTM and eva[®]. *Journal of Financial Intermediation* 16: 312–42. [CrossRef]
- Turnbull, Stuart M. 2018. Capital allocation in decentralized business. *Journal of Risk and Financial Management* 11: 82. [CrossRef]
- Zhang, Yuxuan, Pingke Li, S. Alex Yang, and Simin Huang. 2020. Inventory financing under rorac criterion. Available online: <https://ssrn.com/abstract=3024346> (accessed on 25 May 2020)



Article

Modelling Australian Dollar Volatility at Multiple Horizons with High-Frequency Data

Long Hai Vo ^{1,2} and Duc Hong Vo ^{3,*}

¹ Economics Department, Business School, The University of Western Australia, Crawley, WA 6009, Australia; long.vo@uwa.edu.au

² Faculty of Finance, Banking and Business Administration, Quy Nhon University, Binh Dinh 560000, Vietnam

³ Business and Economics Research Group, Ho Chi Minh City Open University, Ho Chi Minh City 7000, Vietnam

* Correspondence: duc.vhong@ou.edu.vn

Received: 1 July 2020; Accepted: 17 August 2020; Published: 26 August 2020

Abstract: Long-range dependency of the volatility of exchange-rate time series plays a crucial role in the evaluation of exchange-rate risks, in particular for the commodity currencies. The Australian dollar is currently holding the fifth rank in the global top 10 most frequently traded currencies. The popularity of the Aussie dollar among currency traders belongs to the so-called three G's—Geology, Geography and Government policy. The Australian economy is largely driven by commodities. The strength of the Australian dollar is counter-cyclical relative to other currencies and ties proximately to the geographical, commercial linkage with Asia and the commodity cycle. As such, we consider that the Australian dollar presents strong characteristics of the commodity currency. In this study, we provide an examination of the Australian dollar–US dollar rates. For the period from 18:05, 7th August 2019 to 9:25, 16th September 2019 with a total of 8481 observations, a wavelet-based approach that allows for modelling long-memory characteristics of this currency pair at different trading horizons is used in our analysis. Findings from our analysis indicate that long-range dependence in volatility is observed and it is persistent across horizons. However, this long-range dependence in volatility is most prominent at the horizon longer than daily. Policy implications have emerged based on the findings of this paper in relation to the important determinant of volatility dynamics, which can be incorporated in optimal trading strategies and policy implications.

Keywords: exchange-rate risk; long-range dependency; wavelets; multi-frequency analysis; AUD–USD exchange rate

JEL Classification: F31; G32; C58

1. Introduction

In his seminal work advocating for a system of flexible exchange rates, (Friedman 1953) envisaged that speculative forces would have stabilising effects that cause exchange rates to adjust smoothly over time, moving from one equilibrium to another. However, since the breakdown of the Bretton Woods system in 1973, high volatility has been one of the few persistent characteristics of exchange rates. Nevertheless, (Friedman 1953)'s prediction is not without merit, as exchange rates are shown to be less volatile over the longer term, and tend to revert to an equilibrium value that is in close association with relative prices (Lothian 2016); (Marsh et al. 2012). Consider, for example, the values of the US dollar in terms of the Australian dollar. Over the last 45 years, as presented in Panel C of Figure 1, more than 70% of the annual absolute changes of the AUD were greater than 3%, whereas the corresponding number for large relative price changes (Australian price level relative to that of the US) was only approximately 30%. The excess volatility is also apparent for other major currencies, such as the British

Pound, the Deutsch Mark or the Japanese Yen, over the same period, as presented in Panels A, B and D of this figure.

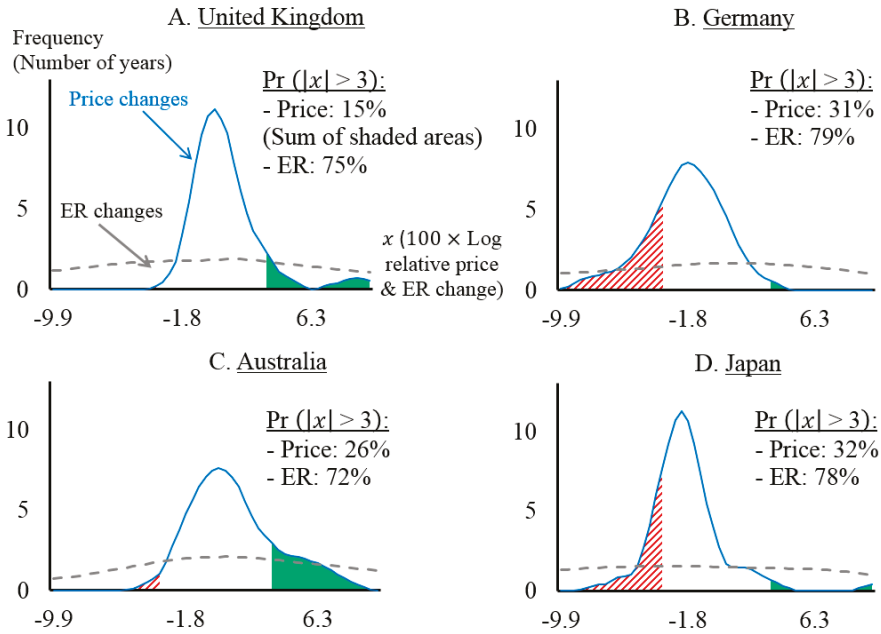

Figure 1. Price and Exchange-Rate Volatilities in the Post Bretton-Woods Era. Notes: Each panel presents the densities of $x_{c,t} = 100 \times (\log X_{c,t} - \log X_{c,t-1})$ ($t = 1974, \dots, 2018$) ($X_{c,t} = S_{c,t}$ or $X_{c,t} = R_{c,t} = P_{c,t}/P_{US,t}$), where $S_{c,t}$ denotes the cost of 1 USD in country c 's currency and $R_{c,t}$ denotes relative prices, defined as the price level, proxied by the CPI of country c ($P_{c,t}$), deflated by that of the US ($P_{US,t}$). The sample period for the Deutsch Mark ends in 1998. To aid presentation, extreme values are not shown. The figures presented in these plots indicate the proportion of relative-price and exchange-rate changes that are greater than 3%, respectively. Source: (Vo 2019); (International Monetary Fund 2019) and authors' calculations.

An extensive body of research has been devoted to the understanding of this excess volatility since the global adoption of floating-rate regimes. See (James et al. 2012) for a recent collection of papers on this topic and other themes of exchange-rate economics. Concurrent with the development of this literature, another strand of research illustrates the stylised fact of long-range dependence, or long memory, in the volatility of multiple financial asset classes including currencies (e.g., Akgül and Sayyan 2008; Aloy et al. 2011). In particular, the response to new information is dragged over a long period due to inefficiency in currency markets (Caporale et al. 2019; Vo and Vo 2019b) leading to long-range dependence of exchange rates. However, the standard statistical techniques proposed to examine long-range dependence, such as the rescaled range method, are inadequate to capture both short- and long-range dependence (Lo 1991). The former is a result of high-frequency autocorrelation or heteroscedasticity. Furthermore, it is distinct from the martingale property. This implies that we need to account for dependence at higher frequencies when drawing empirical inferences of long-range behaviour. This feature may not be sufficiently captured by short-range dependence models (such as an AR(1)).

Another weakness of the existing approaches to modelling long memory is the limited scope of the trading horizon considered. To gauge the importance of this idea, (Vo and Vo 2019a) considered the diverse group of participants operating over different horizons. First, the long-run trends of foreign

exchange rates are the primary concern of a group of market makers whose objective is to ensure currency values are kept consistent with long-term economic fundamentals. Second, at the high end of the frequency spectrum are intraday traders who seek to exploit the volatile currency-value movements and other market inefficiencies to obtain short-term abnormal returns. A wide range of traders exists in between these two extremes. However, when it comes to the examination of long-run dependence in exchange-rate volatility, the conventional two-scale approach reflecting these extremes, that is, short- and long-run, offers a limited solution. Answering the critical questions of “How long is the long-run?” and “What is a possible transition path from short- to long-run?” is important. This is due to the true volatility dynamics being shrouded in the observed data that aggregate the heterogeneous decision-making processes of different traders.

In light of these developments, in this study, we aim to reinvigorate the investigation of the long-run dynamics of exchange rate volatility, with the focus on the Australian dollar. The main justification for the choice of this currency is its interesting relationship with the movements of the main exports of the issuing country. Specifically, when the demand for Australian goods increases, Australia’s terms-of-trade improve. This means that the prices of the primary exports increase relative to those of the imports. Then, the value of the AUD appreciates relative to the currencies of Australia’s trading partners, which is generally termed as a “commodity currency” (Cashin et al. 2004; Chen and Rogoff 2003). As observed in the recent period of the mineral price boom (2003–2013), the appreciation of the AUD has exerted a significant adverse effect on the Australian non-mining exports, such as agricultural and manufacturing products. This is considered as a classic example of the “Dutch disease” or “resource-induced de-industrialisation” phenomenon (Downes et al. 2014). The risk involved in the fluctuation of the AUD value is clear. Understanding the dynamics of exchange-rate volatility is therefore of much interest to policymakers in a small and very open economy like Australia. This insight is crucial for: (i) navigating exchange-rate risks to different sectors of the economy; (ii) planning the government budgets and forecast mining revenues and (iii) evaluating the performance of related forecasts.

As discussed above, though the existing literature has reached a near-consensus agreement on the existence of long memory in exchange-rate volatility, research on the extent to which this dynamic behaviour relates to trading horizons remains inconclusive. In this study, we aim to fill in this gap by examining extensively what trading frequency the risk of a volatile exchange rate persists at. In particular, we are interested in capturing the long-memory behaviour of the Australian dollar at multiple trading horizons with the help of a wavelet decomposition analysis.¹ Specifically, the role of lower-frequency (or longer-horizon) trading activities is documented to be crucial in determining exchange-rate volatility. We also contribute to the literature by providing a clear picture of the long-memory transition path from the short- to long-run.

The remaining paper has the following structure: First, we surveyed and outlined vital studies in the literature regarding the implications and tests of long-memory in foreign-exchange time series in Section 2. Then in Section 3, a brief overview of wavelet methodology is provided, followed by a discussion of the testing procedure for possible structural breaks in the volatility process, which is a potential source for long-range dependency. Section 4 describes our high-frequency data, which serves as the basis for the empirical analyses presented subsequently. Conclusions and implications of our study are provided in Section 5.

¹ The scope for the development of a wavelet-based application on volatility modelling is expected to present significant potential for financial, economic research. As discussed in Section 3, wavelet-based methodology in the field of volatility modelling has been on the rise as a means of filling the gap between short- and long-run analyses.

2. Related Literature

An understanding of the long-memory characteristic of financial processes is crucial in determining optimal investment strategies and asset-portfolio management because of its relevance to market efficiency (Mensia et al. 2014). Specifically, as the presence of long memory in asset returns implies the existence of significant correlations between price observations that are separated in time, this directly contradicts the validity of the Efficient Market Hypothesis (EMH), which suggests the unpredictability of prices and the impossibility of abnormal returns generation. From a different angle, evidence of long memory in the volatility process implies volatility persistence, which suggests that uncertainty is an inherent aspect of the behaviour of exchange rates.

Since long memory affects the riskiness of exchange-rate changes, it also has important implications for the effectiveness of exchange-rate risk hedging. According to (Coakley et al. 2008), the optimal hedge ratio (OHR), also known as the minimum-variance hedge ratio, can be estimated using several well-established methodologies². The prolonged debate on which approach generates the best hedging performance yields mixed evidence (e.g., Moosa 2003; Wen et al. 2017; Jitmaneeroj 2018; Maples et al. 2019; Xu and Lien 2020). This lack of a consensus is partly attributable to the workings of long memory. Specifically, the above approaches assume that the futures premium process generated as the difference between contemporaneous futures and spot prices is stationary. However, in the context of an integrated process of order d ($0 < d < 1$), (Lien and Tse 1999) show theoretically that this will affect the OHR and thus renders the assessment of its relevance for hedging effectiveness difficult.

Adding to the difficulties described above is the fact that conventional statistical tests for stationarity, such as the Dickey–Fuller and Phillips–Perron tests, often falsely lead to non-rejection of the unit-root null hypothesis for exchange rates. This is because the long-memory characteristic of these time series could lower the power of these tests. Relatedly, it can be shown that fractionally integrated processes exhibiting long-range dependence, as opposed to a random walk, can still be stationary (Jiang et al. 2018; Peng et al. 2018). In addition, mean-stationary (with long memory) integrated processes of an order close to unity can be misspecified as fully integrated processes ($d = 1$), because they typically yield indistinguishable unit-root test results. Additionally, the lack of power in unit-root tests can be a source of mixed results for hypotheses relying on such tests such as the purchasing power parity theory (Drine and Rault 2005). This highlights the importance of the careful examination of the long-memory characteristic in time series.

Concerning long-memory research, a method to detect and estimate long-run dependence in the form of the “rescaled range” statistic $R/S(n)$, where n denotes the sample size, was developed by (Hurst 1951). The long-range dependence relationship is implied by $E[R/S(n)] \sim Cn^H$, when $n \rightarrow \infty$. This method aims to estimate the so-called “Hurst exponent” H . As shown by (Vo and Vo 2019b), the parameter H is related to the “fractional” degree of integration d of stochastic processes via the simple expression: $d = H - 0.5$. When modelling volatility, we are mostly interested in the case where $0.5 < H < 1$, which corresponds to a long-memory process. The conventional rescaled-range approach was first adopted by (Booth et al. 1982) to account for long memory in exchange-rate data. However, a weakness of this early developed technique is that it is not robust to the short-range persistence and heteroscedasticity (Caporale et al. 2019; Gil-Alana and Carcel 2020; Ouyang et al. 2016; Youssef and Mokni 2020).

The above discussions show that though the long-memory regularity is important to both investors and forecasters, the related literature has not reached a consensus on how to examine it at different horizons. We add to this debate by exploring the application of an advanced wavelet-based technique recently developed to simultaneously analyse both the time and frequency domains of a

² These methodologies include a least-squares approach whereby the OHR is given by the slope coefficient of the regression line of spot exchange-rate returns against futures returns. Other alternatives such as the error-correction model and the generalised autoregressive conditional heteroscedasticity model can be used to estimate time-varying OHRs.

data generating process. In this study, we combined the strengths of well-established long-memory estimators and wavelet methodology to capture the short-term and long-term dependence structure of financial volatility. A wavelet maximum likelihood estimator is shown to provide superior accuracy in estimating the long-memory parameter compared with the $R/S(n)$ estimator and its variations (Vo and Vo 2019b). In the next section, we describe the particular wavelet-based approach adopted in our analyses.

3. Methodology

3.1. Wavelet Multi-Scale Decomposition

Here, we briefly review the wavelet decomposition methodology. Detailed treatments of the approach can be found in (Mallat 2009). Several of its applications in economics and finance are discussed by (Gencay et al. 2002; In and Kim 2013). First, according to (Baqae 2010), the “mother” wavelet function $\psi(t)$ satisfies:

$$\int_{-\infty}^{\infty} |\psi(t)|^2 dt = 1; \int_{-\infty}^{\infty} \psi(t) dt = 0.$$

These two fundamental conditions constitute the main features of a “small wave”, with unity energy and oscillations dissipating quickly. We used the Discrete Wavelet Transform (DWT) technique developed by (Mallat 2009) in this study, following most applications with finite time series. Specifically, the translated and dilated wavelet function can be expressed as:

$$\psi_{j,k}(t) = 2^{j/2} \psi(2^j t - k),$$

where j and k denote scale and location parameters, respectively. Then, with the combination of the mother wavelet and a complementary component (called the “father” wavelet) ϕ , we can represent any function f as follows:

$$f(t) = \sum_{l \in \mathbb{Z}} \langle f, \phi_l \rangle \phi_l(t) + \sum_{j=0}^{\infty} \sum_{k \in \mathbb{Z}} \langle f, \psi_{j,k} \rangle \psi_{j,k}(t),$$

where $\langle \cdot, \cdot \rangle$ denotes the convolution or inner product between the signal and the filters. The DWT wavelet coefficients can then be computed as $W(j, k) = 2^{j/2} \sum_t x_t \psi(2^j t - k)$ and scaling coefficients as $V(j, k) = 2^{j/2} \sum_t x_t \phi(2^j t - k)$ ($j = 1, \dots, J; k = 1, \dots, n/2^j$) (Gencay et al. 2002).

Next, following the procedure outlined by (Gencay et al. 2010), the “detail” and “smooth” coefficient vectors, (D_j) and (S_j) , were derived, which refer to information about a particular observation and its neighbours. An important characteristic of the DWT is that we can reconstruct X_t from (D_j) and (S_j) . Additionally, the signal energy is preserved by the summation of the variances of the components:

$$X_t = \sum_{j=1}^J D_{j,t} + S_{j,t}; \|X\|^2 = \sum_{j=1}^J \|D_j\|^2 + \|S_j\|^2.$$

In its simplest form, this multi-scale transform is nothing more than taking the “difference of difference” and “average of average” to move from the finest to the coarsest representation levels of the original signal (X_t), while preserving information that is localised in time (Nason 2008). Specifically, at level j , all fluctuations associated with the frequency band $(\frac{1}{2^{j+1}}, \frac{1}{2^j})$ are captured by D_j while all other activities (which are associated with frequencies lower than $(\frac{1}{2^{j+1}})$ are reflected in S_j .

As an illustration, Table 1 links the interpretation of detail levels, various frequency bands and period bands defined in terms of minutes and days (which are computed by dividing the minute column (3) by 1440—the total number of minutes in a day). In particular, in this study, we focused on

frequencies corresponding to periods of 5 up to 40,960 minutes, that is, up to 28.5 days, or approximately one month.

Table 1. Frequency bands of the first 13 decomposition level.

Decomposition Level (j)	Frequency Band $(\frac{1}{2^{j+1}}, \frac{1}{2^j})$	Period Band	
		In minutes ($5 \times 2^j; 5 \times 2^{j+1}$)	In days (5×2^j)/1,440
(1)	(2)	(3)	(4)
0 (original)	0 – 1/2	-	-
1	1/4 – 1/2	5 to 10	0.017
2	1/8 – 1/4	10 to 20	0.014
3	1/16 – 1/8	20 to 40	0.03
4	1/32 – 1/16	40 to 80	0.06
5	1/64 – 1/32	80 to 160	0.11
6	1/128 – 1/64	160 to 320	0.22
7	1/256 – 1/128	320 to 640	0.44
8	1/512 – 1/256	640 to 1280	0.89
9	1/1024 – 1/512	1280 to 2560	1.78
10	1/2048 – 1/1024	2560 to 5120	3.56
11	1/4096 – 1/2048	5120 to 10,240	7.11
12	1/8192 – 1/4096	10,240 to 20,480	14.22
13	1/16,384 – 1/8192	20,480 to 40,960	28.44

Source: Authors' computations.

We can examine our data by means of the DWT described above. The multi-horizon nature of this approach gives it the name “multi-resolution analyses” (MRA). In the empirical application presented in Section 5, we employed several well-established long-memory parameter estimators on the exchange-rate data decomposed using MRA. These include the R/S estimator (Mandelbrot and Van Ness 1968), aggregated variance estimator (Dieker and Mandjes 2003), differenced variance and absolute moment estimators (Teverovsky and Taquq 1997) and Higuchi estimator (Higuchi 1981). See (Vo and Vo 2019b) for discussions regarding these estimators.

Over the last decade, the wavelet-based methodology has gained considerably more attention in the financial volatility modelling literature thanks to its ability to offer powerful insights with respect to horizon-specific dynamics of data generating processes. Recently, (Boubaker 2020) carried out Carlo simulations to compare several wavelet-based estimators and concluded that the Wavelet Exact Local Whittle estimator outperforms the Wavelet OLS and Wavelet Geweke–Porter–Hudak estimators and generates more accurate results to identify the fractional integration parameter for symmetric heavy-tailed distributions. One of the most important applications of this novel line of research is the analyses of co-movement patterns among asset classes at different investment frequencies that could potentially offer hedging strategies to mitigate market-wise and sector downside risks. Recent related studies include (Ghosh et al. 2020), who adopted a wavelet-based time-varying dynamic approach for estimating the medium- and long-range conditional correlation among various financial and energy assets to determine their hedge ratios. Along a similar vein, (Kang et al. 2019) found strong evidence of volatility persistence, causality and phase differences between Bitcoin and gold futures prices. In addition, wavelet-filtered data are used to capture movements of Bitcoin returns at various investment horizons, and form the basis for the examination of Bitcoin's ability to hedge global uncertainty (Bouri et al. 2017).

To the best of our knowledge, applications of wavelet-based methodology to the currency markets are much more limited compared to other financial markets, a fact we seek to change with the contributions of this paper.

3.2. Testing for Structural Breaks in the Presence of Long Memory

In this section; we describe a procedure with which we can test for the existence of possible multiple structural breaks; which is a source of long memory in volatility. Previous research has documented that structural breaks in the mean can partly explain the persistence of realised volatility (Choi et al. 2010), but the effect of structural breaks could also mask that of true long memory and thus lead to misspecifications (Sibbertsen 2004). Therefore; we need to account for the possibility of structural breaks in our data. Specifically; we were firstly interested in fitting a univariate GARCH model to our data using several alternative specifications that are prominent in the literature. In GARCH models, the normalised density function is often written in terms of the location and scale parameters as:

$$\alpha_t = (\mu_t, \sigma_t, \omega),$$

where the conditional mean and variance are given by:

$$\mu_t = \mu(\theta, r_t) = E(v_t | r_t); \sigma_t^2 = \sigma^2(\theta, r_t) = E[(v_t - \mu_t)^2 | r_t],$$

with r_t and v_t denoting returns and volatility, and $\omega = \omega(\theta, r_t)$ is the remaining parameters of the distribution.

Here, for simplicity, we assumed an ARIMA (1,1) model for the mean equation, normal distribution of the error terms and different GARCH (1,1) specifications for the variance equation. These include the standard GARCH (Bollerslev 1986), the exponential GARCH/eGARCH (Nelson 1991) and the GJR GARCH (Glosten et al. 1993), which account for asymmetric volatilities and the fractionally-integrated GARCH/fiGARCH (Baillie et al. 1996), which accounts for fractionally integrated (long-memory) processes.³ For example, the specific equations for the standard GARCH (1,1) models are:

$$\Phi(L)(1-L)(v_t - \mu_t) = \Theta(L)\varepsilon_t; \sigma_t^2 = \omega + \alpha_1 \varepsilon_{t-1}^2 + \beta_1 \sigma_{t-1}^2,$$

with L denoting the lag operator and ε_t the residual from the mean filtration process. The asymmetric GARCH models (eGARCH and GJR GARCH) have an additional parameter γ capturing the degree of asymmetry. In contrast, the fiGARCH model has an additional parameter d that captures the degree of long memory.

After fitting these GARCH models, we performed tests for structural breaks by applying a Change Point Model (CPM) on the corresponding model residuals. We aimed to detect multiple change points in a sequence of observations of the volatility process, with different CPMs such as the t -tests proposed by (Hawkins et al. 2003); the Bartlett test (Hawkins and Zamba 2005a); the Generalised Likelihood Ratio test (Hawkins and Zamba, Statistical process control for shifts in mean or variance using a changepoint formulation (Hawkins and Zamba 2005b); the Mann–Whitney test (Ross, Tasoulis, & Adams, Nonparametric monitoring of data streams for changes in location and scale, (Ross et al. 2011); the Mood test (Ross et al. 2011) and the Kolmogorov–Smirnov test (Ross and Adams 2012). While the first three methods are designed to capture change points in Gaussian processes, the others are for non-Gaussian processes.

4. Results

Our five-minute USD/AUD nominal exchange rates (measured as the AUD cost of 1 USD, instead of the default AUD/USD rate) are provided by the commercial data vendor Bloomberg. The data coverage period is from 18:05, 7th August 2019 to 9:25, 16th September 2019—a total of $T = 8481$ intervals/observations. This period was selected when the analysis was conducted. In addition, we

³ Note that when $d = 0$, the FIGARCH (1,d,1) model collapses to the standard GARCH(1,1), while when $d = 1$, it collapses to iGARCH(1,1).

considered that a total of 8481 observations is sufficient for the analysis using our selected technique. We selected the closing ask USD/AUD rate as our subject of study. Figure 2 presents MRA plots for this time series, starting with the original level in the top-left plot and ends with the coarsest smoothed series in the bottom-right plot. In between these cases are detailed series corresponding to the 13 decomposition levels presented in Table 1. Note that the original data can be reconstructed by the direct summation of all the components. It can be seen clearly that noisy fluctuations are captured by higher-frequency detail series (D_1 to D_8) while these noises can be filtered out in lower-frequency details (D_9 to D_{13}) and in the smooth component (S_{13}).

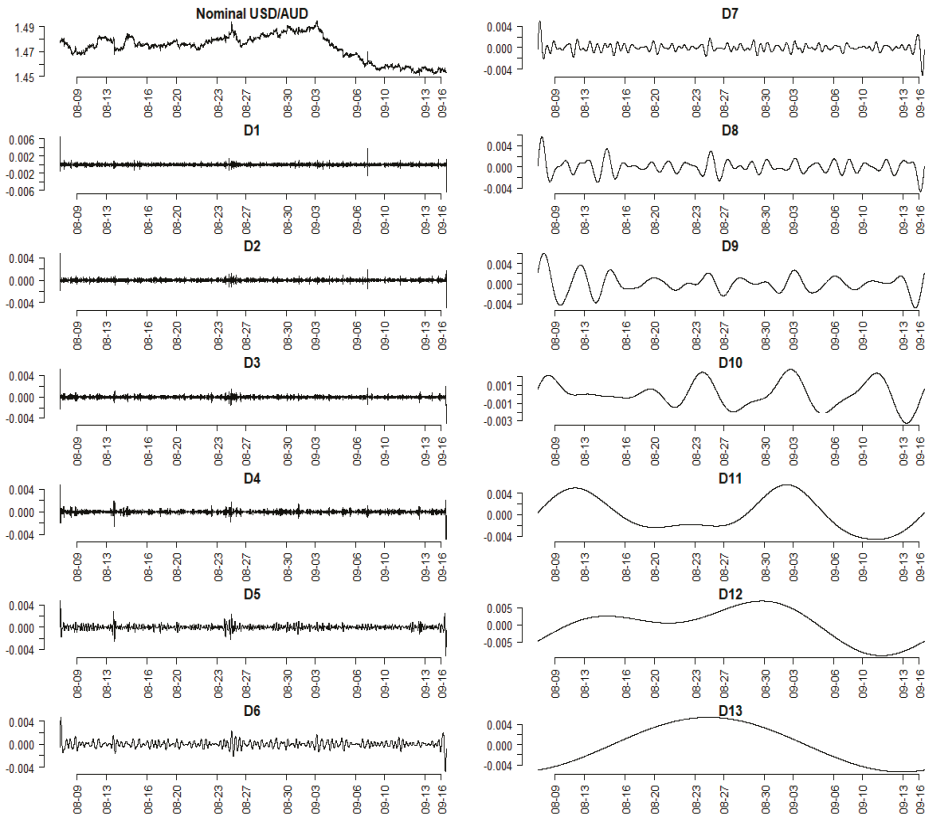

Figure 2. Multi-resolution plots of USD/AUD time series. Notes: This figure presents the MRA for the full data range from 7th August 2019, to 9:25, 16th September 2019. In each panel, the horizontal axis indicates the corresponding days of the two months.

The continuously compounded exchange rate returns are computed as the differences of logarithmic five-minute exchange rates: $r_{it} = \log p_{it} - \log p_{i,t-1}$ ($t = 1, \dots, T$). Exchange rate volatility is proxied by the 288-interval (or one-day) rolling standard deviations of returns, that is, $\sigma_{it} = \sqrt{(1/288) \sum_{j=2}^{289} [(\log p_{i,t+j} - \log p_{i,t+j-1}) - \bar{r}_{it}]^2}$, where $\bar{r}_{it} = (1/288) \sum_{j=2}^{289} (\log p_{i,t+j} - \log p_{i,t+j-1})$ is the rolling average return. This means the first 288 return observations are set aside for the computation of the first realized volatility value, leaving us with 8193 observations.

Summary statistics of the volatility and return series are presented in Table 2. Overall, the return series distribution resembles normality, albeit having high kurtosis. On the other hand, the volatility is left-skewed, as, by construction, it only contains positive values. To examine the long-range dependence pattern of our data, Figure 3 illustrates the corresponding five-minute auto-correlograms, or visualised autocorrelation function (ACF), for the two series. As can be seen, the return series exhibit no significant autocorrelation pattern after the first lag, while the volatility series clearly demonstrates long-range dependence.

Table 2. Summary statistic of five-minute USD/AUD returns and volatilities.

	Mean	Median	Variance	Skewness	Kurtosis	JB	LB(21)
Returns	0.000001	0.00	0.00	0.72	422.12	3881823130.38 (0.00)	9022.43 (0.00)
Volatilities	0.000412	0.000393	0.00	3.70	33.17	25166002.26 (0.00)	10405779.70 (0.00)

Notes: Returns of the USD/AUD exchange rate are computed as the log-change of the corresponding five-minute spot USD/AUD: $r_{it} = \log p_{it} - \log p_{i,t-1}$ ($t = 1, \dots, T$), where p_{it} denotes the nominal exchange rate. T denotes the number of observations (8193 five-minute intervals). Volatilities are defined as the one-day rolling standard deviations of r_{it} . JB and LB denote the Jarque–Bera and the Ljung–Box statistics, respectively. p -values are in parentheses. Source: Authors’ computations.

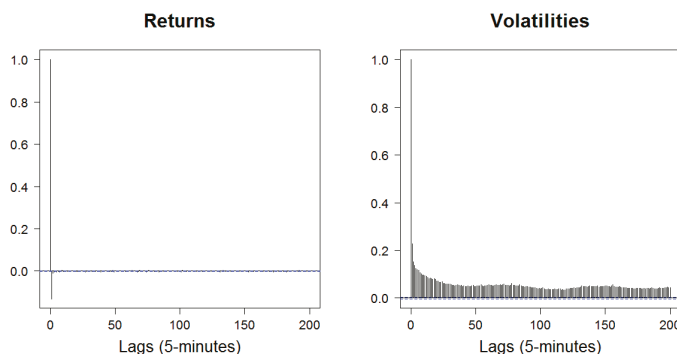

Figure 3. Auto-correlograms of USD/AUD high-frequency returns and volatilities. Notes: Exchange-rate returns are computed as the log-change of the corresponding five-minute closing spot rates: $r_{it} = \log p_{it} - \log p_{i,t-1}$ ($t = 1, \dots, 8193$). Volatilities are defined as the one-day rolling standard deviations of r_{it} . Source: Authors’ computations.

4.1. A Multi-Resolution Analysis

Our main question of interest is “At which particular horizons does the long-memory behaviour of the USD/AUD exchange rate persist?” To answer this, Table 3 presents estimates of the Hurst index as applied to the original series as well as the 12 levels of smooth components which capture all activities at frequencies lower than $\frac{1}{2^{j+1}}$ and thus preserve the underlying trends of the volatility.⁴ As can be seen from this table, the volatility measures of five-minute AUD/USD returns exhibit a very persistent pattern of long memory, at all levels of decomposition, where the Hurst index estimated using all methods is significantly larger than 0.5. This means that there are no frequencies that are solely responsible for the long-range dependence characteristic of the Australian dollar. This could be explained by the fact that the trader base of this open-economy currency is quite diverse and active, who tend to switch trading

⁴ On the other hand, “detail” components reflect the fluctuations (or differences) of volatility series and thus are not representative of the long-range dependent behaviour.

horizons frequently via diversification/rebalancing operations. This makes disentangling the impacts of activities at a particular frequency from those at other frequencies difficult.⁵

Table 3. Long-memory parameter estimates of exchange-rate volatility at different horizons.

Smooth Level	R/S	aggVar	diffVar	absVal	Higuchi
Original	1.101 (0.062)	0.966 (0.064)	1.620 (0.179)	0.980 (0.047)	0.966 (0.030)
1	1.146 (0.085)	0.966 (0.064)	1.618 (0.166)	0.980 (0.047)	0.966 (0.030)
2	1.056 (0.063)	0.966 (0.064)	1.747 (0.184)	0.980 (0.047)	0.966 (0.030)
3	0.994 (0.044)	0.966 (0.064)	1.663 (0.142)	0.980 (0.047)	0.966 (0.030)
4	0.988 (0.033)	0.967 (0.064)	1.833 (0.164)	0.980 (0.047)	0.966 (0.030)
5	1.005 (0.034)	0.968 (0.064)	1.965 (0.187)	0.981 (0.047)	0.966 (0.030)
6	1.008 (0.034)	0.972 (0.065)	2.174 (0.236)	0.984 (0.047)	0.966 (0.030)
7	1.003 (0.027)	0.978 (0.066)	1.756 (0.196)	0.986 (0.048)	0.965 (0.030)
8	0.990 (0.017)	0.988 (0.063)	1.803 (0.168)	0.992 (0.047)	0.965 (0.030)
9	0.993 (0.014)	0.997 (0.050)	1.932 (0.127)	0.999 (0.037)	0.966 (0.030)
10	1.000 (0.008)	1.003 (0.027)	1.669 (0.154)	1.007 (0.019)	0.966 (0.030)
11	0.999 (0.007)	1.001 (0.003)	1.364 (0.240)	1.005 (0.010)	0.966 (0.030)
12	0.999 (0.006)	1.002 (0.004)	1.468 (0.152)	1.005 (0.008)	0.966 (0.030)

Notes: Nomenclatures: (1) R/S: Rescaled range; (2) aggVar: Aggregated variance; (3) diffVar: Differenced variance; (4) AbsVar: Absolute moments; (5) Higuchi: Higuchi's method. Heteroskedasticity-robust standard errors are in parentheses. Refer to Table 2 for interpretation of the decomposition levels/time-scales. Source: Authors' computations.

4.2. Horizon-Based Power Decomposition

Given the highly persistent pattern of long memory observed in AUD/USD volatility, it is now fruitful to analyse the multi-scale composition of power (or variations) of the original nominal five-minute exchange rate. To do this, in Figure 4 we present a "heat map" representation of the MRA as proposed by (Torrence and Compo 1998), which illustrates the power scale of the original series through both time and frequencies. Stronger colours (i.e., red or orange) at any frequency and time represent higher power scales and stronger cyclical behaviour.⁶ We performed wavelet decomposition only up to the horizon corresponding to 512 five-minute intervals. This design allowed us to investigate

⁵ Additionally, the behaviour of exchange rates can be related to the dynamic long-memory properties of other economic variables, such as the aggregated price levels (via the purchasing power parity relationship) or the interest rates (via the uncovered interest parity relationship).

⁶ The computation is done this time with a continuous Morlet wavelet transform, rather than a DWT. Due to some issues with this operator, certain information outside the region outlined by the parabolic curve (the "cone of influence") should be ignored. (e.g., (Daubechies 1992) for details.)

the interaction dynamics of the intraday volatility process. The map reveals features that are in close conjunction with the cyclical behaviour of the series, which is not easy to discern without the map. Specifically, frequencies corresponding to the periods of 256 to 512 five-minute intervals are observed to exhibit the highest power while no strong cyclical pattern can be observed at higher frequencies. These results corroborate those of (Caporale et al. 2019).

In agreement with Figure 2, though at shorter horizons there are only small intraday noises, there exist large (but infrequent) movements at the longer horizons in the AUD/USD exchange-rate dynamics. Interestingly, it can also be seen that there are two episodes of volatility spillover between the low frequencies and the high frequencies in this sample: The August 13th and the September 10th. These days are also associated with episodes of relatively high volatility. The former effect is tied in with the release of the statement on monetary policy by the Reserve Bank of Australia on August 9th, while the more prominent effect on the second date could be a result of market anticipation during the week leading to the meetings of the Federal Open Market Committee (US) and Reserve Bank Board (Australia) meetings, both of which are on September 17th. In the next subsection, we investigated possible breaks in the volatility process in more details.

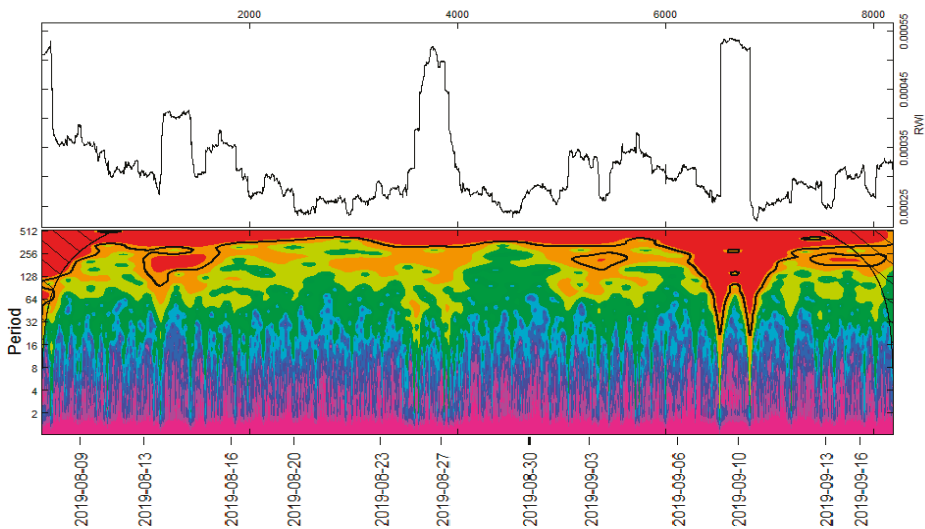

Figure 4. Wavelet heat map of five-minute nominal USD/AUD exchange rate. Notes: Horizontal axis ranges from 0 to 8193, the number of five-minute intervals in our sample. The vertical axis indicates the horizons (in five-minute) corresponding to the frequencies at which the underlying time series fluctuates. The power meter is located beneath the graph. The area within the parabolic region indicates the “zone of influence”. The plots were drawn using functions provided in the R package *dplR* (Bunn 2008). Source: Authors’ computations.

4.3. Sources of Long Memory: Structural Breaks

Table 4 presents the estimated results for the alternative GARCH (1,1) models discussed in Section 3. The likelihood value and information criteria are in agreement that the most appropriate model is the eGARCH, followed by the standard GARCH, then the fiGARCH and GJRGARCH. Interestingly, the long-memory parameter estimates implied by fiGARCH ($d = 0.85$) again confirm the long-memory characteristic of the volatility process.

Table 4. GARCH (1,1) models estimates.

	GARCH		eGARCH		GJRGARCH		fiGARCH	
μ	0.00	(0.00)	0.00	(0.33)	0.00	(0.00)	0.00	(0.00)
AR_1	-0.07	(0.07)	0.13	(0.02)	-0.06	(0.70)	-0.10	(0.05)
MA_1	-0.15	(0.07)	-0.35	(0.00)	-0.13	(0.40)	-0.16	(0.00)
ω	0.00	(0.00)	-2.85	(0.00)	0.00	(1.00)	0.00	(0.98)
α_1	0.07	(0.03)	0.03	(0.00)	0.05	(0.00)	0.06	(0.00)
β_1	0.90	(0.02)	0.82	(0.00)	0.90	(0.00)	0.86	(0.00)
γ or d	-	-	0.32	(0.00)	0.05	(0.00)	0.85	(0.00)
Log-likelihood	54,649.75		54,767.86		54,228.44		54,358.09	
Information Criteria								
Akaike	-13.34		-13.37		-13.24		-13.27	
Bayes	-13.33		-13.36		-13.23		-13.26	
Shibata	-13.34		-13.37		-13.24		-13.27	
Hannan–Quinn	-13.34		-13.37		-13.23		-13.27	

Notes: This table presents estimation results for different GARCH (1,1) specifications described in Section 4. The last row of parameter estimates refers to the asymmetric parameter γ for the eGARCH and GJRGARCH models, while for the fiGARCH model this refers to the fractional differential parameter d . p -Values based on robust standard errors in parentheses.

Based on these estimates, we were able to extract the residuals of these models and apply the CPMs described in Section 4 to test for breakpoints of the (conditional) volatility process. Test results are presented in Table 5. We can see that the number of structural breaks detected is substantial, given the high frequency of our data.⁷ Importantly, the breaks exist for models exclusively designed to capture long memory, such as fiGARCH, regardless of the assumption of the underlying distribution.

Table 5. Number of breakpoints detected using different test statistics.

Test Type	Test For	GARCH	eGARCH	GJRGARCH	fiGARCH
Student	Mean changes	102	113	93	112
Bartlett	Variance changes	181	177	191	181
GLR	Mean and variance changes	155	154	163	146
B. Tests in a (possibly unknown) non-Gaussian process					
MW	Location shifts	115	115	112	113
M	Scale shifts	48	54	44	57
KS	Arbitrary changes	61	71	53	65

Notes: The tests listed are applied to residuals from the GARCH models described in Table 5. Nomenclatures: GLR (Generalised Likelihood Ratio), MW (Mann–Whitney), M (Mood) and KS (Kolmogorov–Smirnov). Sources: Authors’ examinations and computations.

5. Discussions, Conclusions and Implications

5.1. Discussions

We contribute to the existing literature by providing a careful examination of the time series characteristics of the AUD/USD exchange rate at a very high frequency, which has important economic implications. As a final note, we conjecture that long memory is observed for this series and is persistent throughout the trading horizons, which implies that investors should be wary of such changes when managing their portfolios. Secondly, rather than focusing on short-term fluctuations and gains, an optimal trading horizon would preferably be longer than half-day, as this could capture more fundamental trend information of the exchange-rate return processes.

⁷ The exact time periods when the breaks are detected are not presented here to conserve space but are available upon request.

Our study complements the findings of (Caporale et al. 2019), who documented the persistence of both returns and volatility processes of the EUR/USD and USD/JPY exchange rates at lower trading frequencies. In agreement with this paper, we concur that such evidence against random-walk behaviour implies predictability and is inconsistent with the Efficient Market Hypothesis since abnormal profits can be made using trading strategies based on trend analysis. We also extended this research by introducing the wavelet-based long-memory estimator, as opposed to relying on conventional tools such as the R/S statistic or the fractional integration analysis. Another recent study related to ours is (Boubaker 2020) whose Monte Carlo simulation results suggest that when it comes to estimating the long-memory parameter in stationary time series, the Wavelet Exact Local Whittle estimator outperforms the Wavelet OLS and Wavelet Geweke–Porter–Hudak estimators in terms of smaller bias. It would be interesting to extend this comparison exercise to include our Wavelet MLE approach and apply these estimators on actual data (rather than on simulations).

This study is subject to two qualifications. First of all, due to our limited access to high-frequency exchange-rate data, we were unable to examine further the implication of our results for the Australian dollar for other (commodity) currencies. A possibly more general conclusion can be drawn when more of these valuable data are available to us.⁸ Secondly, our research is limited to the currency market. Applying the same approach to other financial markets such as stocks, bonds or commodity futures to examine their volatility persistence and the workings of the EMH offers an interesting future research venue.

5.2. Conclusions and Implications

Existing literature indicates that the choice of an appropriate statistical tool for analysing exchange-rate dynamics should ultimately be made based on the long-memory properties of the underlying data generating process, which varies across different trading horizons. The Australian dollar is generally considered as a representative commodity currency given the performance of the Australian economy is mainly driven by commodities and the Australian dollar is one of the top 10 most frequently traded currencies in the world. As such, this study was conducted to examine the Australian dollar-US dollar exchange rates—one of the most popular and frequently traded pairs of currencies. This study covers the period from 18:05, 7th August 2019 to 9:25, 16th September 2019 with a total of 8481 observations—a sufficient number of observations required for our analysis. In this paper, we used a wavelet-based approach that allows for modelling long-memory characteristics of this important currency pair at different trading horizons.

The high-frequency behaviour of exchange rates observed from our study would be valuable for designing and evaluating exchange-rate models and/or forecasts. More generally, these insights can potentially be used to evaluate the currency risks related to the Australian trade balance, trade flows, terms-of-trade, prices of foreign-exchange futures (or options) and/or international asset portfolio formation.

Author Contributions: Theoretical frameworks surveyed conducted are done by L.H.V. Both authors conduct reviews of empirical analyses. The original draft is prepared by D.H.V. Reviewing and editing are done by both authors. All authors have read and agreed to the published version of the manuscript.

Funding: This research was funded by Ho Chi Minh City Open University, Vietnam [E2020.14.1].

⁸ Nevertheless, in a recent study (Vo and Vo 2019b) have applied wavelet-based estimators on daily data of six heavily traded currencies, including AUD, and have shown cross-currency results that are similar to ours.

Acknowledgments: Part of this research was completed when Long Vo was a Master student at the School of Economics and Finance, Victoria University of Wellington, where he received financial support from a New Zealand-ASEAN Scholar Award provided by the New Zealand Ministry of Foreign and Trade. Duc Vo acknowledges the financial assistance from Ho Chi Minh City Open University. We thank the editor and three anonymous referees whose comments helped improve the paper. All remaining errors are our own.

Conflicts of Interest: The authors declare no conflict of interest.

References

- Akgül, Isil, and Hulya Sayyan. 2008. Modelling and forecasting long memory in exchange rate volatility vs. stable and integrated GARCH models. *Applied Financial Economics* 18: 463–83. [\[CrossRef\]](#)
- Aloy, Marcel, Mohamed Boutahar, Karine Gente, and Anne Peguin-Feissolle. 2011. Purchasing power parity and the long memory properties of real exchange rates: Does one size fit all? *Economic Modelling* 28: 1279–90. [\[CrossRef\]](#)
- Baillie, Richard, Tim Bollerslev, and Hans Ole Mikkelsen. 1996. Fractionally integrated generalised autoregressive conditional heteroskedasticity. *Journal of Econometrics* 74: 3–30. [\[CrossRef\]](#)
- Baqae, David. 2010. Using wavelets to measure core inflation: The case of New Zealand. *North American Journal of Economics and Finance* 21: 241–55. [\[CrossRef\]](#)
- Bollerslev, Tim. 1986. Generalised autoregressive conditional heteroskedasticity. *Journal of Econometrics* 31: 307–27. [\[CrossRef\]](#)
- Booth, Geoffrey, Fred Kaen, and Peter Koveos. 1982. R/S analysis of foreign exchange rates under two international monetary regimes. *Journal of Monetary Economics* 10: 407–15. [\[CrossRef\]](#)
- Boubaker, Heni. 2020. Wavelet estimation performance of fractional integrated processes with heavy-tails. *Computational Economics* 55: 473–98. [\[CrossRef\]](#)
- Bouri, Elie, Rangan Gupta, Aviral Kumar Tiwari, and David Roubaud. 2017. Does bitcoin hedge global uncertainty? Evidence from wavelet-based quantile-in-quantile regressions. *Finance Research Letter* 23: 87–95. [\[CrossRef\]](#)
- Bunn, Andrew. 2008. A dendrochronology program library in R (dplR). *Dendrochronologia* 26: 115–124. [\[CrossRef\]](#)
- Caporale, Guglielmo Maria, Luis Gil-Alana, and Alex Plastun. 2019. Long memory and data frequency in financial markets. *Journal of Statistical Computation and Simulation* 89: 1763–79. [\[CrossRef\]](#)
- Cashin, Paul, Luis Céspedes, and Ratna Sahay. 2004. Commodity currencies and the real exchange rate. *Journal of Development Economics* 75: 239–68. [\[CrossRef\]](#)
- Chen, Yu-chin, and Kenneth Rogoff. 2003. Commodity currencies. *Journal of International Economics* 60: 133–60. [\[CrossRef\]](#)
- Choi, Kyongwook, Wei-Choun Yu, and Eric Zivot. 2010. Long memory versus structural breaks in modeling and forecasting realised volatility. *Journal of International Money and Finance* 29: 857–75. [\[CrossRef\]](#)
- Coakley, Jerry, Jian Dollery, and Neil Kellard. 2008. The role of long memory in hedging effectiveness. *Computational Statistics and Data Analysis* 52: 3075–82. [\[CrossRef\]](#)
- Daubechies, Ingrid. 1992. *Ten Lectures on Wavelets*. Philadelphia: Society for Industrial and Applied Mathematics.
- Dieker, Antonius, and Michael Mandjes. 2003. On spectral simulation of fractional Brownian motion. *Probability in the Engineering and Informational Sciences* 17: 417–34. [\[CrossRef\]](#)
- Downes, Peter, Kevin Hanslow, and Peter Tulip. 2014. *The Effect of the Mining Boom on the Australian Economy. (RDP 2014–08)*. Research Discussion Paper. Sydney: Reserve Bank of Australia.
- Drine, Imed, and Christophe Rault. 2005. Can the Balassa-Samuels theory explain long-run real exchange rate movements in OECD countries? *Applied Financial Economics* 15: 519–30. [\[CrossRef\]](#)
- Friedman, Milton. 1953. The case for flexible exchange rates. In *Essays in Positive Economics*. Chicago: University of Chicago Press, pp. 157–203.
- Gencay, Ramazan, Faruk Selcuk, and Brandon Whitcher. 2002. *An Introduction to Wavelets and Other Filtering Methods in Finance and Economics*. San Diego: Academic Press.
- Gencay, Ramazan, Nikola Gradojevic, Faruk Selcuk, and Brandon Whitcher. 2010. Asymmetry of information flow between volatilities across time scales. *Quantitative Finance* 10: 895–915. [\[CrossRef\]](#)
- Ghosh, Indranil, Manas Sanyal, and Rabin Jana. 2020. Co-movement and dynamic correlation of financial and energy markets: An integrated framework of nonlinear dynamics, wavelet analysis and DCC-GARCH. *Computational Economics*. [\[CrossRef\]](#)

- Gil-Alana, Luis, and Hector Carcel. 2020. A fractional cointegration var analysis of exchange rate dynamics. *The North American Journal of Economics and Finance* 51: 100848. [CrossRef]
- Glosten, Lawrence, Ravi Jagannathan, and David Runkle. 1993. On the relation between the expected value and the volatility of the nominal excess return on stocks. *Journal of Finance* 48: 1779–1801. [CrossRef]
- Hawkins, Douglas, and Gideon K. D. Zamba. 2005a. A change-point model for a shift in variance. *Journal of Quality Technology* 37: 21–31. [CrossRef]
- Hawkins, Douglas, and Gideon K. D. Zamba. 2005b. Statistical process control for shifts in mean or variance using a changepoint formulation. *Technometrics* 47: 164–73. [CrossRef]
- Hawkins, Douglas, Peihua Qiu, and Chang Wook Kang. 2003. The changepoint model for statistical process control. *Journal of Quality Technology* 35: 355–66. [CrossRef]
- Higuchi, Tomoyuki. 1981. Approach to an irregular time series on the basis of the fractal theory. *Physica D: Nonlinear Phenomena* 31: 277–83. [CrossRef]
- Hurst, Harold. 1951. Long term storage capacity of reservoirs. *Transaction of the American Society of Civil Engineer* 116L: 770–99.
- In, Francis, and Sangbae Kim. 2013. *An Introduction to Wavelet Theory in Finance: A Wavelet Multiscale Approach*. Singapore: World Scientific.
- International Monetary Fund. 2019. International Financial Statistics. Available online: <https://data.imf.org/?sk=4C514D48-B6BA-49ED-8AB9--52B0C1A0179B> (accessed on 5 April 2019).
- James, Jessica, Ian Marsh, and Lucio Sarno. 2012. *Handbook of Exchange Rates*. Hoboken: Wiley.
- Jiang, Yongchong, He Nie, and Weihua Ruan. 2018. Time-varying long-term memory in Bitcoin market. *Finance Research Letters* 25: 280–84. [CrossRef]
- Jitmaneeroj, Boonlert. 2018. The effect of the re-balancing horizon on the tradeoff between hedging effectiveness and transaction costs. *International Review of Economics and Finance* 58: 282–98. [CrossRef]
- Kang, Sang Hoon, Ron McIver, and Jose Arreola Hernandez. 2019. Co-movements between Bitcoin and gold: A wavelet coherence analysis. *Physica A: Statistical Mechanics and Its Applications* 536: 120888. [CrossRef]
- Lien, Donald, and Yiu Kuen Tse. 1999. Fractional cointegration and futures hedging. *Journal of Futures Markets* 19: 457–74. [CrossRef]
- Lo, Andrew. 1991. Long-term memory in stock market prices. *Econometrica* 59: 1279–313. [CrossRef]
- Lothian, James. 2016. Purchasing power parity and the behavior of prices and nominal exchange rates across exchange-rate regimes. *Journal of International Money and Finance* 69: 5–21. [CrossRef]
- Mallat, Stéphane. 2009. *A Wavelet Tour of Signal Processing: The Sparse Way*. Amsterdam: Academic Press.
- Mandelbrot, Benoit, and John Van Ness. 1968. Fractional Brownian motions, fractional noises and applications. *SIAM Review* 10: 422–37. [CrossRef]
- Maples, William, Wade Brorsen, and Xiaoli Etienne. 2019. Hedging effectiveness of fertiliser swaps. *Applied Economics* 51: 5793–801. [CrossRef]
- Marsh, Ian, Evgenia Passari, and Lucio Sarno. 2012. Purchasing power parity in tradable goods. In *J Handbook of Exchange Rates*. Edited by Jessica James, Ian Marsh and Lucio Sarno. Hoboken: Wiley, vol. 2, pp. 189–220.
- Mensia, Walid, Shawkat Hammoudeh, and Seong-Min Yoon. 2014. Structural breaks and long memory in modeling and forecasting volatility of foreign exchange markets of oil exporters: The importance of scheduled and unscheduled news announcements. *International Review of Economics and Finance* 30: 101–19. [CrossRef]
- Moosa, Imad. 2003. The sensitivity of the optimal hedging ratio to model specification. *Finance Letter* 1: 15–20.
- Nason, Guy. 2008. *Wavelet Methods in Statistics with R*. Berlin: Springer.
- Nelson, Daniel. 1991. Conditional heteroskedasticity in asset returns: A new approach. *Econometrica* 59: 347–70. [CrossRef]
- Ouyang, Alice, Ramkishan Rajan, and Jie Li. 2016. Exchange rate regimes and real exchange rate volatility: Does inflation targeting help or hurt? *Japan and the World Economy* 39: 62–72. [CrossRef]
- Peng, Lu, Shan Liu, Rui Liu, and Lin Wang. 2018. Effective long short-term memory with differential evolution algorithm for electricity price prediction. *Energy* 162: 1301–14. [CrossRef]
- Ross, Gordon, and Niall Adams. 2012. Two nonparametric control charts for detecting arbitrary distribution changes. *Journal of Quality Technology* 44: 102–16. [CrossRef]
- Ross, Gordon, Dimitris Tasoulis, and Niall Adams. 2011. Nonparametric monitoring of data streams for changes in location and scale. *Technometrics* 53: 379–89. [CrossRef]

- Sibbertsen, Philipp. 2004. Long memory versus structural breaks: An overview. *Statistical Papers* 45: 465–515. [\[CrossRef\]](#)
- Teverovsky, Vadim, and Murad Taqqu. 1997. Testing for long-range dependence in the presence of shifting means or a slowly declining trend, using a variance-type estimator. *Journal of Time Series Analysis* 18: 279–304. [\[CrossRef\]](#)
- Torrence, Christopher, and Gilbert Compo. 1998. A practical guide to wavelet analysis. *Bulletin of the American Meteorological Society* 79: 61–78. [\[CrossRef\]](#)
- Vo, Hai Long. 2019. Exchange Rates, Prices and Consumption. Ph.D. thesis, Economics Department, The University of Western Australia, Perth, WA, Australia.
- Vo, Hai Long, and Duc Hong Vo. 2019a. Application of wavelet-based maximum likelihood estimator in measuring market risk for fossil fuel. *Sustainability* 11: 2843. [\[CrossRef\]](#)
- Vo, Hai Long, and Duc Hong Vo. 2019b. Long-run dynamics of currency markets: A multi-frequency investigation. *North American Journal of Economics and Finance*, 101125. [\[CrossRef\]](#)
- Wen, Xiaoqian, Elie Bouri, and David Roubaud. 2017. Can energy commodity futures add to the value of carbon assets? *Economic Modelling* 62: 194–206. [\[CrossRef\]](#)
- Xu, Yingying, and Donald Lien. 2020. Optimal futures hedging for energy commodities: An application of the GAS model. *Journal of Futures Markets* 40: 1090–1108. [\[CrossRef\]](#)
- Youssef, Manel, and Khaled Mokni. 2020. Modeling the relationship between oil and USD exchange rates: Evidence from a regime-switching-quantile regression approach. *Journal of Multinational Financial Management* 55: 100625. [\[CrossRef\]](#)



© 2020 by the authors. Licensee MDPI, Basel, Switzerland. This article is an open access article distributed under the terms and conditions of the Creative Commons Attribution (CC BY) license (<http://creativecommons.org/licenses/by/4.0/>).

Article

A Note on Simulation Pricing of π -Options

Zbigniew Palmowski ^{*,†} and Tomasz Serafin [†]

Faculty of Pure and Applied Mathematics, Wrocław University of Science and Technology,
ul. Wyb. Wyspiańskiego 27, 50-370 Wrocław, Poland; tomaszserafin.96@gmail.com

* Correspondence: zbigniew.palmowski@pwr.edu.pl; Tel.: +48-71-320-2012

† These authors contributed equally to this work.

Received: 8 July 2020; Accepted: 24 August 2020; Published: 28 August 2020

Abstract: In this work, we adapt a Monte Carlo algorithm introduced by Broadie and Glasserman in 1997 to price a π -option. This method is based on the simulated price tree that comes from discretization and replication of possible trajectories of the underlying asset's price. As a result, this algorithm produces the lower and the upper bounds that converge to the true price with the increasing depth of the tree. Under specific parametrization, this π -option is related to relative maximum drawdown and can be used in the real market environment to protect a portfolio against volatile and unexpected price drops. We also provide some numerical analysis.

Keywords: π -option; American-type option; optimal stopping; Monte Carlo simulation

MSC: 49L20; 60G40

JEL Classification: G13; C61

1. Introduction

In this paper, we analyze π -options introduced by [Guo and Zervos \(2010\)](#) that depends on so-called relative drawdown and can be used in hedging against volatile and unexpected price drops or by speculators betting on falling prices. These options are the contracts with a payoff function:

$$g(S_T) = (M_T^a S_T^b - K)^+ \quad (1)$$

in case of the call option and

$$g(S_T) = (K - M_T^a S_T^b)^+ \quad (2)$$

in the case of put option, where

$$S_t = S_0 \exp\left(\left(r - \frac{\sigma^2}{2}\right)t + \sigma B_t\right) \quad (3)$$

is an asset price in the Black-Scholes model under martingale measure, i.e., r is a risk-free interest rate, σ is an asset's volatility and B_t is a Brownian motion. Moreover,

$$M_t = \sup_{w \leq t} S_w$$

is a running maximum of the asset price and T is its maturity. Finally, a and b are some chosen parameters.

A few very well-known options are particular cases of a π -option. In particular, taking $a = 0$ and $b = 1$ produces an American option and by choosing $a = 1$ and $b = 0$ we derive a lookback option. Another interesting case, related to the concept of drawdown (see [Figure 1](#)), is when $-a = b = 1$

and $K = 1$. Then the pay-out function $(K - M_T^a S_T^b)^+ = 1 - \frac{S_T^b}{M_T^a} = \frac{M_T - S_t}{M_T} = D_T^R$ equals the relative drawdown D_T^R , defined as a quotient of the difference between maximum price and the present value of the asset and the past maximum price. In other words, D_T^R corresponds to the percentage drop in price from its maximum. We take a closer look at this specific parametrization of the π -option in the later sections, starting from Section 3.2.

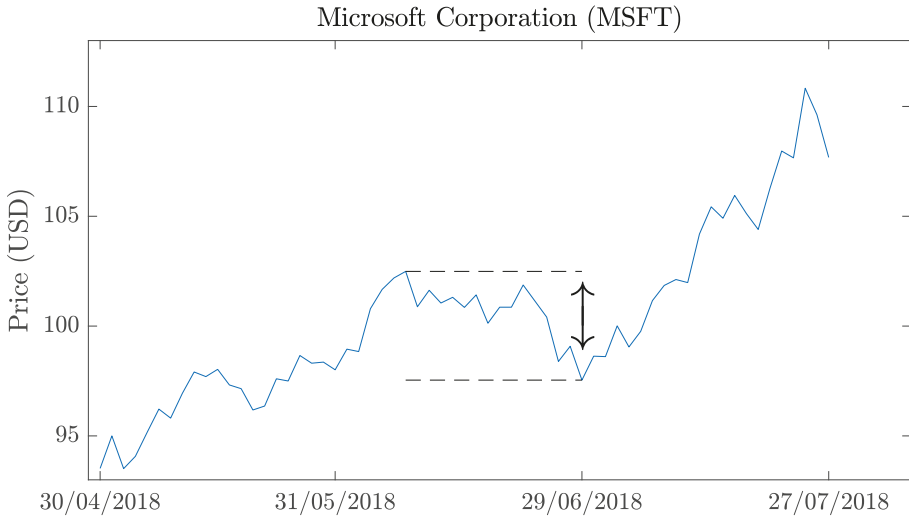

Figure 1. A sample drawdown for the Microsoft Corporation stock is marked with black arrows and dashed lines. Data is taken from www.finance.yahoo.com.

Monte Carlo simulations are widely used in pricing in financial markets they have proved to be valuable and flexible computational tools to calculate the value of various options as witnessed by the contributions of Barraquand and Martineau (1995); Boyle (1977); Boyle et al. (1997); Broadie et al. (1997); Cafilisch (1998); Clément et al. (2002); Dyer and Jacob (1991); Geske and Shastri (1985); Glasserman (2004); Jäckel (2002); Joy et al. (1996); Longstaff and Schwartz (2001); Niederreiter (1992); Raymar and Zwecher (1997); Rogers (2002); Tilley (1993); Tsitsiklis and van Roy (1999, 2001); Resenburt and Torrie (1993); Villani (2010). One of the first attempts of Monte Carlo simulation for American options is by Tsitsiklis and van Roy (1999) where the backward induction algorithm was introduced. However, as appears later, Tilley method suffers from exponentially increasing computational cost as the number of dimensions (assets) increases. Broadie et al. (1997) to overcome this problem offered a non-recombining binomial simulation approach instead combined with some pruning technique to reduce computation burden and other variance reduction techniques to increase precision. In the same year Broadie and Glasserman (1997) construct computationally cheap lower and upper bounds to the American option price. This method is used in this paper. An alternative way to formulate the American option pricing problem is in terms of optimal stopping times. This is done in Carriere (1996), where it was proved that finding the price of American option can be based on a backwards induction and calculating several conditional expectations. This observation gives another breakthrough in pricing early exercise derivatives by Monte Carlo done by Longstaff and Schwartz (2001). They propose least square Monte Carlo (LSM) method which has proved to be versatile and easy to implement. The idea is to estimate the conditional expectation of the payoff from continuing to keep the option alive at each possible exercise point from a cross-sectional least squares regression using the information in the simulated paths. To do so we have to then solve some minimization problem. Therefore, this method is still computationally expensive. Some improvements of this method have been also proposed; see also Stentoft (2004a, 2004b) who gave theoretical foundation of LSM and properties of its estimator.

There are other, various pricing methods in the case of American-type options; we refer Zhao (2018) for review. We must note though that not all of them are good for simulation of prices of general π -options as it is a path-dependent product. In particular, in pricing π -options one cannot use finite difference method introduced by Brennan and Schwartz (1978); Schwartz (1977) which uses a linear combination of the values of a function at three points to approximate a linear combination of the values of derivatives of the same function at another point. Similarly, the analytic method of lines of Carr and Faguet (1994) is not available for pricing general π -options. One can use though a binomial tree algorithm (or trinomial model) though which goes backwards in time by first discounting the price along each path and computing the continuation value. Then this algorithm compares the former with the latter values and decide for each path whether or not to exercise; see Broadie and Detemple (1996) for details and references therein. It is a common belief that Monte Carlo method is more efficient than binomial tree algorithm in case of path-dependent financial instruments. It has another known advantages as handling time-varying variants, asymmetry, abnormal distribution and extreme conditions.

In this paper, we adapt a Monte Carlo algorithm proposed in 1997 by Broadie and Glasserman (1997) to price π -options. This numerical method replicates possible trajectories of the underlying asset's price by a simulated price tree. Then, the values of two estimators, based on the price tree, are obtained. They create an upper and a lower bound for the true price of the option and, under some additional conditions, converge to that price. The first estimator compares the early exercise payoff of the contract to its expected continuation value (based on the successor nodes) and decides if it is optimal to hold or to exercise the option. This estimation technique is one of the most popular ones used for pricing American-type derivatives. However, as shown by Broadie and Glasserman (1997), it overestimates the true price of the option. The second estimator also compares the expected continuation value and early exercise payoff, but in a slightly different way, which results in underestimation of the true price. Both Broadie–Glasserman Algorithms (BGAs) are explained and described precisely in Section 2. The price tree that we need to generate is parameterized by the number of nodes and by the number of branches in each node. Naturally, the bigger the numbers of nodes and branches, the more accurate price estimates we get. The obvious drawback of taking a bigger price tree is that the computation time increases significantly with the size of the tree. However, in this paper we show that one can take a relatively small price tree and still the results are satisfactory.

The Monte Carlo simulation presented in this paper can be used in corporate finance and especially in portfolio management and personal finance planning. Having American-type options in the portfolio, the analyst might use the Monte Carlo simulation to determine its expected value even though the allocated assets and options have varying degrees of risk, various correlations and many parameters. In fact determining a return profile is a key ingredient of building efficient portfolio. As we show in this paper portfolio with π -options out-performs typical portfolio with American put options in hedging investment portfolio losses since it allows investors to lock in profits whenever stock prices reaches its new maximum.

In this paper, we use BGA to price the π -option on relative drawdown for the Microsoft Corporation's (MSFT) stock and for the West Texas Intermediate (WTI) crude oil futures. Input parameters for the algorithm are based on real market data. Moreover, we provide an exemplary situation in which we explain the possible application of the π -option on relative drawdown to the protection against volatile price movements. We also compare this type of option to an American put and outline the difference between these two contracts.

This paper is organized as follows. In the next section we present the Broadie–Glasserman Algorithm. In Section 3 we use this algorithm to numerically study π -options for the Microsoft Corporation's stock and WTI futures. Finally, in the last section, we state our conclusions and recommendations for further research in this new and interesting topic.

2. Monte Carlo Algorithm

Formulas identifying the general price of π -option are known in some special cases and they are given in terms of so-called scale functions and hence in terms of the solution of some second order ordinary differential equations; see for example, (Christensen 2013, chp. 5) and Egami and Oryu (2017) for details and further references. Still, the formulas are complex, and a Monte Carlo method of pricing presented in this paper is very efficient and accurate alternative method. In this section we present a detailed description of the used algorithm. In particular, we give formulas for two estimators, one biased low and one biased high, that under certain conditions converge to the theoretical price of the option.

2.1. Preliminary Notations

We adapt the Monte Carlo method introduced by Broadie and Glasserman (1997) for pricing American options. In this algorithm, values of two estimators are calculated on the so-called price tree that represents the underlying's behavior over time. This tree is parametrized by the number of nodes n and the number of branches in each node—denoted by l . For example, the tree with parameters $n = 2, l = 3$ is depicted in Figure 2.

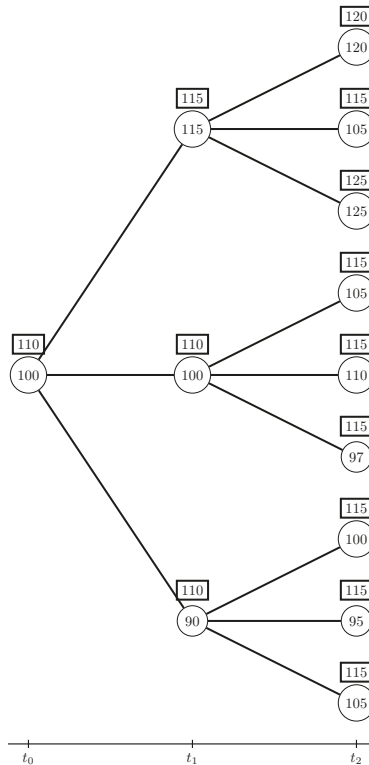

Figure 2. An example of the price tree. Underlying's price is marked with circles and corresponding maximums are marked with rectangles.

To apply the numerical algorithm, we must discretize the price process given in (3), by considering the time sequence $t_0 = 0 < t_1 < \dots < t_n = T$ with $t_i = i\frac{T}{n}$ for $i = 0, \dots, n$. By

$$S_{t_i^{l_1, \dots, l_i}}$$

we denote the asset's price at the time $t_i = i\frac{T}{n}$. The upper index l_1, \dots, l_i , associated with t_i , describes the branch selection (see Figure 3) in each of the tree nodes and allows us to uniquely determine the path of the underlying's price process up to time t_i . Similarly, we define

$$M_{t_i^{l_1, \dots, l_i}} = \max_{k \leq i} S_{t_k^{l_1, \dots, l_k}}.$$

We introduce the state variable $\tilde{S}_{t_i^{l_1, \dots, l_i}} = (S_{t_i^{l_1, \dots, l_i}}, M_{t_i^{l_1, \dots, l_i}})$ as well.

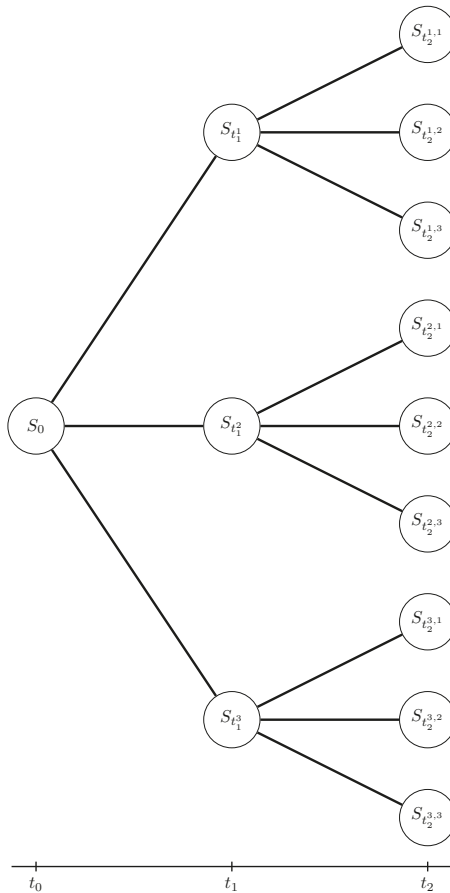

Figure 3. Branch selecting.

We relate with it the payoff of an immediate exercise (for π -put) at time t_i in the state $\tilde{S}_{t_i^{l_1, \dots, l_i}}$ given by

$$h_{t_i}(\tilde{S}_{t_i^{l_1, \dots, l_i}}) = (K - S_{t_i^{l_1, \dots, l_i}}^a M_{t_i^{l_1, \dots, l_i}}^b)^+$$

and the expected value of holding the option from t_i to t_{i+1} , given asset's value $\tilde{S}_{t_i^{1,\dots,i}}$ at time t_i defined via

$$g_{t_i}(\tilde{S}_{t_i^{1,\dots,i}}) = \mathbb{E} \left[e^{-\frac{r}{n}} f_{t_{i+1}}(\tilde{S}_{t_{i+1}^{1,\dots,i+1}}) \middle| \tilde{S}_{t_i^{1,\dots,i}} \right],$$

where

$$f_{t_i}(\tilde{S}_{t_i^{1,\dots,i}}) = \max\{h_{t_i}(\tilde{S}_{t_i^{1,\dots,i}}), g_{t_i}(\tilde{S}_{t_i^{1,\dots,i}})\}$$

is the option value at time t_i in state $\tilde{S}_{t_i^{1,\dots,i}}$. Please note that

$$f_{t_n}(\tilde{S}_{t_n^{1,\dots,n}}) = f_T(\tilde{S}_{T^{1,\dots,n}}) = h_T(\tilde{S}_{T^{1,\dots,n}}) = (K - S_{T^{1,\dots,n}}^a M_{T^{1,\dots,n}}^b)^+.$$

2.2. Estimators

We will now give the formulas for the estimators Θ and Φ which overestimate and underestimate the true price of the option, respectively. Then, we will state the main theorem showing that both estimators are asymptotically unbiased and that they converge to the theoretical price of the π -option. We also provide a detailed explanation of the estimation procedure based on the exemplary price tree. In all calculations we consider a π -put option with parameters $a = -1, b = 1$ and $K = 1$. Additionally, we assume that the risk-free rate used for discounting the payoffs equals 5%.

2.2.1. The Θ Estimator

The formula for the estimator is recursive and given by:

$$\Theta_{t_i} = \max \left\{ h_{t_i}(\tilde{S}_{t_i^{1,\dots,i}}), e^{-\frac{r}{n}} \frac{1}{l} \sum_{j=1}^l \Theta_{t_{i+1}^{1,\dots,i+j}} \right\}, \quad i = 0, \dots, n - 1.$$

At the option's maturity, T , the value of the estimator is given by

$$\Theta_T = f_T(\tilde{S}_T).$$

The Θ estimator, at each node of the price tree, chooses the maximum of the payoff of the option's early exercise at time t_i , $h_{t_i}(\tilde{S}_{t_i^{1,\dots,i}})$, and the expected continuation value, i.e., the discounted average payoff of successor nodes. Figure 4 shows how the value of Θ estimator is obtained given the certain realization of a price tree. All calculations are also shown below:

- **(a)** $\left\{ \begin{array}{l} \text{Holding value: } \frac{0 + \frac{10}{110} + 0}{3} e^{-0.05} \approx \underline{0.028} \\ \text{Early exercise: } 0 \end{array} \right.$
- **(b)** $\left\{ \begin{array}{l} \text{Holding value: } \frac{\frac{5}{110} + 0 + \frac{13}{110}}{3} e^{-0.05} \approx 0.052 \\ \text{Early exercise: } \frac{10}{110} \approx \underline{0.091} \end{array} \right.$
- **(c)** $\left\{ \begin{array}{l} \text{Holding value: } \frac{\frac{10}{110} + \frac{15}{110} + \frac{5}{110}}{3} e^{-0.05} \approx 0.086 \\ \text{Early exercise: } \frac{20}{110} \approx \underline{0.182} \end{array} \right.$
- **(d)** $\left\{ \begin{array}{l} \text{Holding value: } \frac{0.028 + 0.091 + 0.182}{3} e^{-0.05} \approx \underline{0.095} \\ \text{Early exercise: } \frac{10}{110} \approx 0.091 \end{array} \right.$

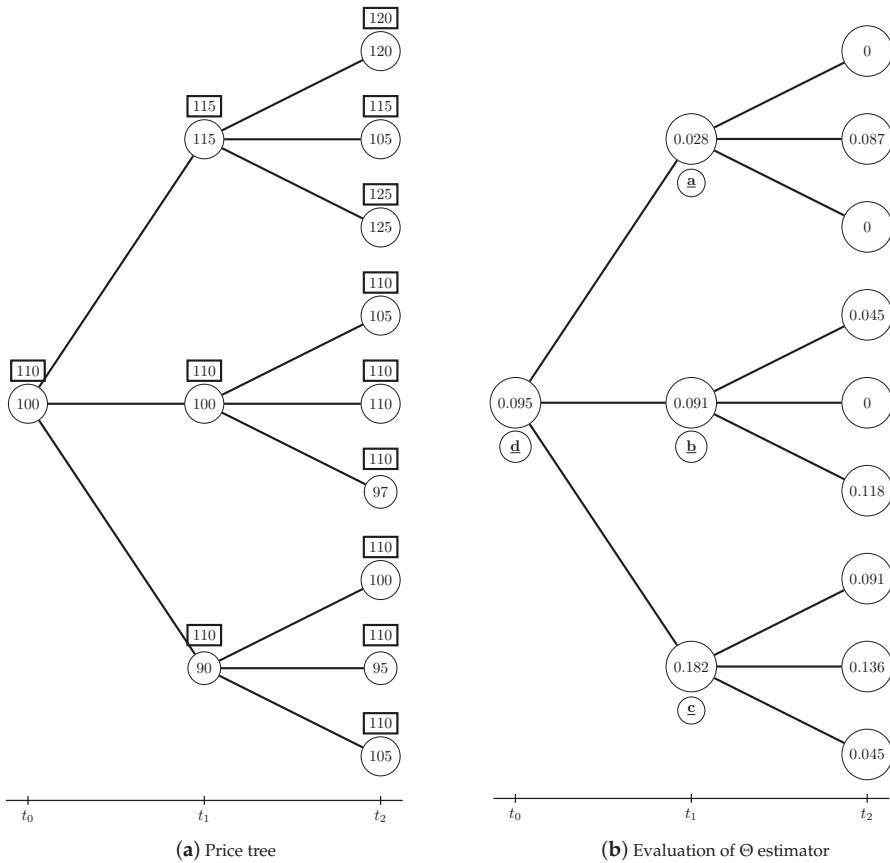

Figure 4. Explanation of Θ estimator.

2.2.2. The Φ Estimator

The Φ estimator is also defined recursively. Before we give the formula we need to introduce an auxiliary function ζ by

$$\zeta_{t_i}^j = \begin{cases} h_{t_i}(\tilde{S}_{t_i}^{1, \dots, l_i}), & \text{if } h_{t_i}(\tilde{S}_{t_i}^{1, \dots, l_i}) \geq e^{-\frac{r}{n}} \frac{1}{l-1} \sum_{\substack{k=1 \\ k \neq j}}^l \Phi_{t_{i+1}}^{1, \dots, l_i, k} \\ e^{-\frac{r}{n}} \Phi_{t_{i+1}}^{1, \dots, l_i, j}, & \text{if } h_{t_i}(\tilde{S}_{t_i}^{1, \dots, l_i}) < e^{-\frac{r}{n}} \frac{1}{l-1} \sum_{\substack{k=1 \\ k \neq j}}^l \Phi_{t_{i+1}}^{1, \dots, l_i, k} \end{cases} \quad (4)$$

for $j = 1, \dots, l$. Now we can define the Φ estimator in the following way:

$$\begin{cases} \Phi_{t_i}^{1, \dots, l_i} = \frac{1}{l} \sum_{j=1}^l \zeta_{t_i}^j \\ \Phi_T = f_T(\tilde{S}_T). \end{cases} \quad (5)$$

The formula for this estimator is more complicated. Therefore, we provide a detailed explanation of the mechanism behind the algorithm in the following part of this section. In our explanation we refer

to Figure 5. Please note that in the following example, underlined numbers correspond to the final values associated with the specific branches of the tree.

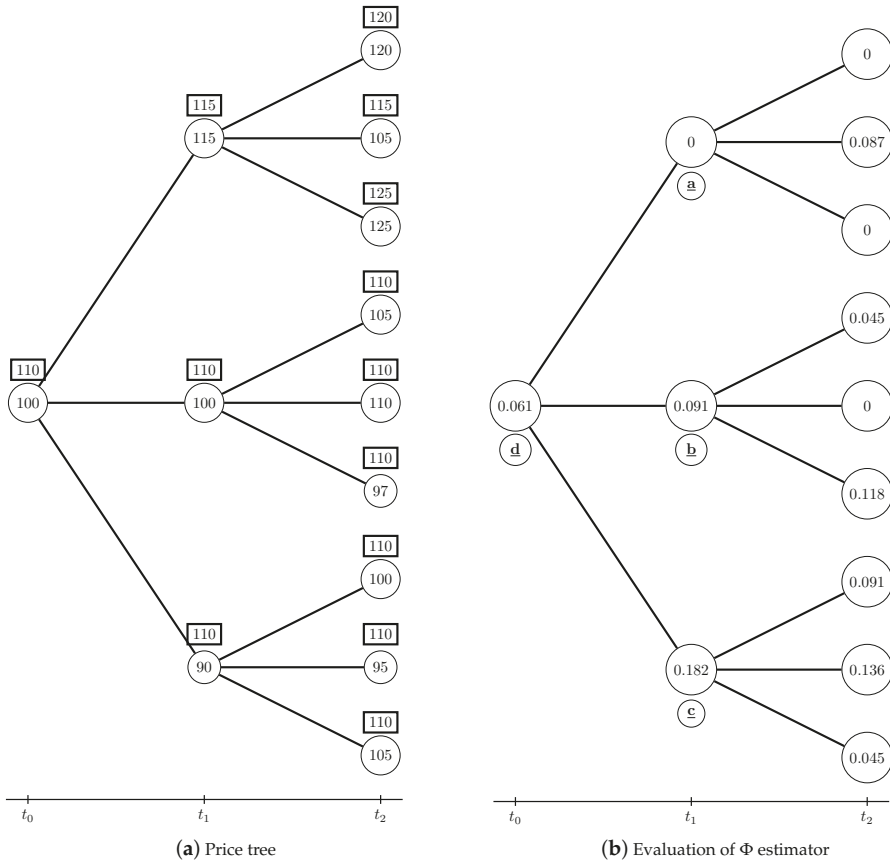

Figure 5. Explanation of Φ estimator.

- $\left\{ \begin{array}{l} \text{Early exercise: } 0 \\ \text{Holding value for branch } j = 1: \frac{0.087+0}{2}e^{-0.05} \approx 0.041 > 0 \rightarrow \underline{0} \\ \text{Holding value for branch } j = 2: \frac{0+0}{2}e^{-0.05} = 0 \leq 0 = h_i(\tilde{S}_i) \rightarrow \underline{0} \\ \text{Holding value for branch } j = 3: \frac{0+0.087}{2}e^{-0.05} \approx 0.041 > 0 \rightarrow \underline{0} \end{array} \right.$

For the branch $j = 1$ we look at the two remaining ones to determine whether early exercising (payoff = 0) or holding the option (payoff = $\frac{0.087+0}{2}e^{-0.05}$) is more profitable. Obviously, early exercise is not optimal, so we hold the option and thus, as the value of $\zeta_{t_1}^1$ we take the payoff of the branch $j = 1$ which is 0.

For the branch $j = 2$ both early exercise value and holding value from two other branches equals 0. Thus, from (4) the value of $\zeta_{t_1}^2$ equals the payoff of early exercise, which is 0.

For the third branch, again holding the option is a more profitable decision (based on the payoffs of the two remaining branches). Thus, $\zeta_{t_1}^3$ takes the value corresponding to the branch $j = 3$ and it is 0.

Now the value of the estimator for node **(a)** is the sum of $\xi_{t_1}^j$ across all branches:

$$\Phi_{t_1} = \frac{1}{3} \sum_{j=1}^3 \xi_{t_1}^j = 0.$$

Similarly, we have the following values of our estimator.

- **(b)**
 - Early exercise: $\frac{10}{110} \approx 0.091$
 - Holding value for branch $j = 1$: $\frac{0+0.118}{2} e^{-0.05} \approx 0.056 < 0.091 \rightarrow 0.091$
 - Holding value for branch $j = 2$: $\frac{0.045+0.118}{2} e^{-0.05} \approx 0.078 < 0.091 \rightarrow 0.091$
 - Holding value for branch $j = 3$: $\frac{0.045+0}{2} e^{-0.05} \approx 0.021 < 0.091 \rightarrow 0.091$

In this case, the value of the estimator for the **(b)** node equals 0.091.

- **(c)**
 - Early exercise: $\frac{20}{110} \approx 0.182$
 - Holding value for branch $j = 1$: $\frac{0.045+0.136}{2} e^{-0.05} \approx 0.086 < 0.182 \rightarrow 0.182$
 - Holding value for branch $j = 2$: $\frac{0.091+0.045}{2} e^{-0.05} \approx 0.065 < 0.182 \rightarrow 0.182$
 - Holding value for branch $j = 3$: $\frac{0.091+0.136}{2} e^{-0.05} \approx 0.108 < 0.182 \rightarrow 0.182$

For node **(c)** the value of the estimator is 0.182.

- **(d)**
 - Early exercise: $\frac{10}{110} \approx 0.091$
 - Holding value for branch $j = 1$: $\frac{0.091+0.182}{2} e^{-0.05} \approx 0.13 > 0.091 \rightarrow 0$
 - Holding value for branch $j = 2$: $\frac{0.0+0.182}{2} e^{-0.05} \approx 0.087 < 0.091 \rightarrow 0.091$
 - Holding value for branch $j = 3$: $\frac{0+0.091}{2} e^{-0.05} \approx 0.043 < 0.091 \rightarrow 0.091$

The value of the estimator for this node equals $\frac{0+0.091+0.091}{3} = 0.061$. This is also the (under)estimated value of the option.

Following arguments of [Broadie and Glasserman \(1997\)](#), one can easily prove the following crucial fact.

Theorem 1. *Both Θ and Φ are consistent and asymptotically unbiased estimators of the option value. They both converge to the true price of the option as the number of price tree branches, l , increases to infinity. For a finite l :*

- *The bias of the Θ estimator is always positive, i.e.,*

$$\mathbb{E}[\Theta_0(l)] \geq f_0(\tilde{S}_0).$$

- *The bias of the Φ estimator is always negative, i.e.,*

$$\mathbb{E}[\Phi_0(l)] \leq f_0(\tilde{S}_0).$$

On every realization of the price tree, the low estimator Φ is always less than or equal to the high estimator Θ , i.e.,

$$\mathbb{P}(\Phi_{t_1}^{i_1, \dots, i_l} \leq \Theta_{t_1}^{i_1, \dots, i_l}) = 1.$$

3. Numerical Analysis

In this section, we will present results of the numerical analysis. First, we use the algorithm described above to price the American option with arbitrary parameters. This will allow us to confirm that our Monte Carlo algorithm produces precise estimates of options' prices. We focus on options related to Microsoft Corporation stock. Next, we price π -options for several combinations of parameters. We also consider π -option on drawdown using the real market data and we compare

it with an American put, which is one of the most popular tool for protecting our portfolio against price drops.

3.1. American Options

First of all, we decided to check the robustness of the Monte Carlo pricing algorithm. We estimate prices of the American call options with different strike prices. In the example, the underlying asset price S_0 equals 100, $\sigma = 20\%$, risk-free rate $r = 5\%$ and the maturity is 30 days. In Table 1 we present the results of the estimation. Please note that when using the Broadie–Glasserman algorithm, we obtain the upper and the lower boundaries of the option price. To obtain the American option price estimate we average both values.

Table 1. Comparison of the estimated and ‘real’ American option prices with different strikes. Absolute percentage errors are also included.

Strike	Low Est.	High Est.	Estimated Price	Real Price	Abs. Perc. Err.
\$80	\$20.16	\$20.55	\$20.36	\$20.33	0.14%
\$85	\$15.10	\$15.54	\$15.32	\$15.35	0.19%
\$90	\$10.28	\$10.62	\$10.45	\$10.43	0.19%
\$95	\$5.84	\$6.02	\$5.93	\$5.89	0.68%
\$100	\$2.54	\$2.60	\$2.57	\$2.51	2.36%
\$105	\$0.76	\$0.77	\$0.77	\$0.73	5.33%
\$110	\$0.16	\$0.16	\$0.16	\$0.14	13.35%

3.2. π -Options

We will analyze put π -option for various combinations of parameters a and b . We assume that parameter a is varying from -1.1 to -0.9 and b parameter between 0.9 and 1.1 . The ranges of these parameters have been chosen arbitrarily for illustrative purposes. All input parameters for options pricing, S_0 , M_0 , volatility and interest rate are taken from the real market data for the Microsoft Corporation stock (MSFT) and are given in Table 2. The numerical results are presented in Figure 6.

Table 2. Input parameters for pricing π -put option on the Microsoft Corporation stock.

Parameter	Value
S_0	106.08
M_0	110.83
σ	17.03%
r	1.5%
l	65
K	1

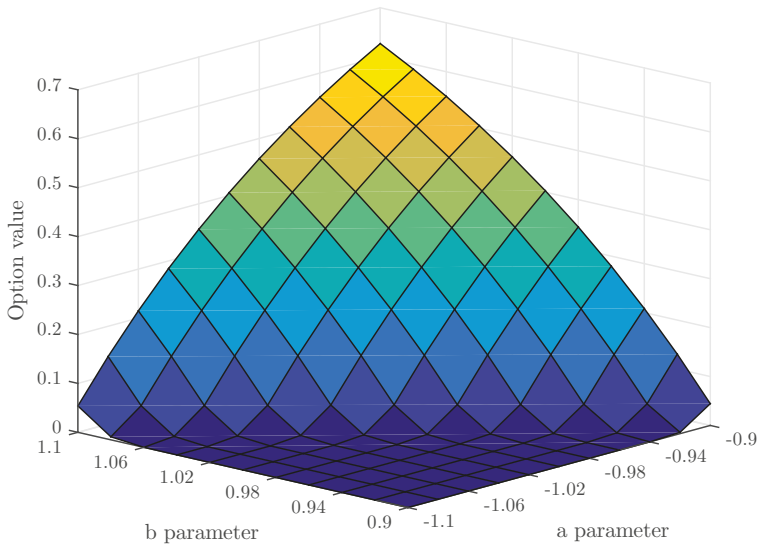

Figure 6. π -option price estimations for varying a and b —Microsoft Corporation stock.

3.3. π -Options on Relative Drawdown

Recall that for $a = -1$ and $b = 1$ the payoff of the π -option equals

$$\left(K - \frac{S_t}{M_t}\right)^+, \tag{6}$$

where S_t/M_t is the current value of the relative drawdown of the underlying asset. We believe that such contracts could be very efficiently used for hedging and managing portfolio risk against the volatile drops in underlying’s price (see Section 3.4). One can adjust the payoff function (6) by the appropriate choice of the strike K . The choice is arbitrary and solely dependent on the risk management goals of the option’s buyer. It allows the setting of the minimal size of drawdown we would like to protect against and let the buyer adjust and full control of the level of our exposure at risk associated with unexpected price drops. For example by setting $K = \frac{9}{10}$, the payoff of our option becomes greater than zero only if the drop in the price of the underlying from its maximum exceeds 10%. Of course, the bigger the value of K , the more expensive the option is.

We take a closer look at the impact of M_t and K on the price of this special case of π -option. Here, we assume that the maximum price M_t is between 100 and 120 and K ranges between 0.8 and 1. This time, the remaining parameters, namely S_0 , r and σ , have been arbitrarily chosen for illustrative purposes and are given in Table 3. The results are shown in Figure 7.

Table 3. Input parameters for pricing π -option on relative drawdown.

Parameter	Value
S_0	100
σ	20%
r	5%
l	100

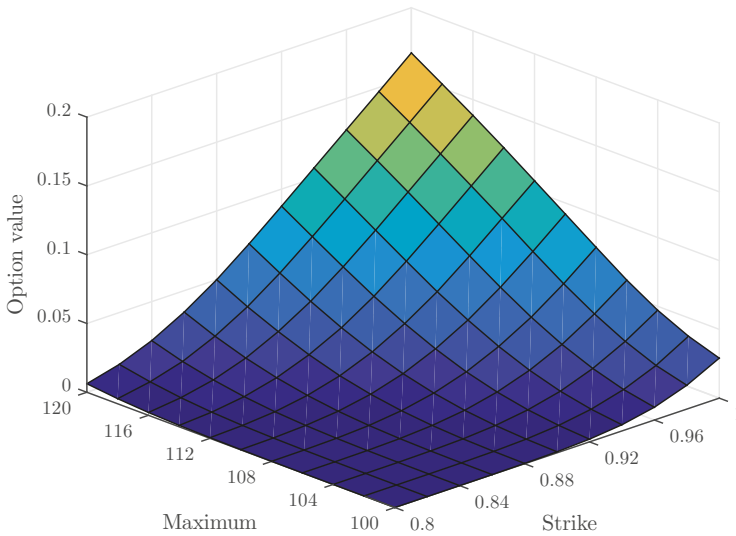

Figure 7. π -option on relative drawdown price estimations for varying K and M_0 parameters.

3.4. π -Options on Relative Drawdown - Application

We now focus on the potential application of π -options and compare the prices of American put and π -option on relative drawdown. We compare these particular instruments due to the fact that their values increase with the decrease of the underlying asset’s price. As an exemplary environment for the options comparison we choose two time series containing daily closing prices of the Microsoft Corporation’s stock (see Figure 8) as well as daily closing prices of the West Texas Intermediate (WTI) crude oil futures (see Figure 9). Both datasets are taken from www.finance.yahoo.com and span approximately one year, from 6 November 2017 to 9 November 2018. We use the first 9 months (from 6 November 2017 to 3 August 2018) to calibrate the historical volatility for both assets, which is one of the input parameters in our pricing algorithm.

Then, using the historical volatility, we compute prices of π and American options (using assets’ prices from 3 August 2018), both expiring 3 months after the end of calibration period. Please note that the parameters for the π -option on a relative drawdown are $a = -1$, $b = 1$ and $K = 1$. Input parameters for calculation and estimated options prices for both assets are given in Tables 4 and 5.

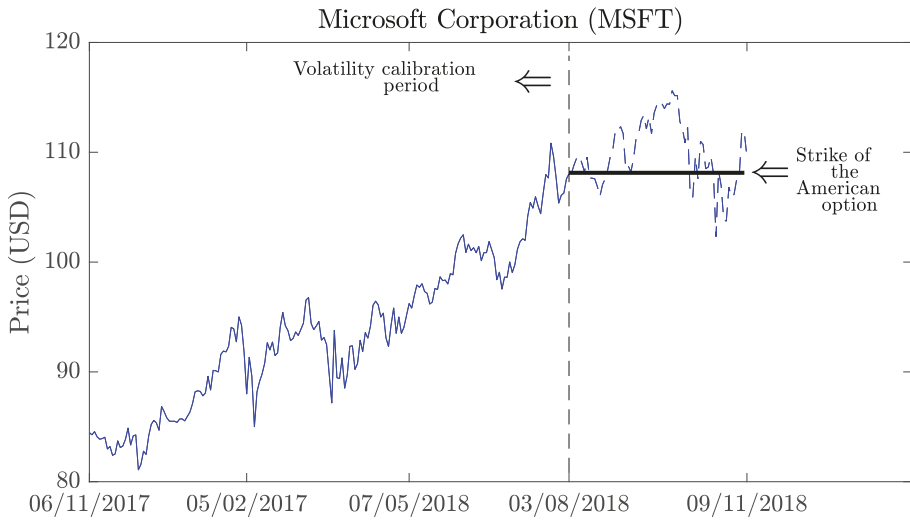

Figure 8. Daily closing prices of the Microsoft Corporation’s stock. Data spans from 6.11.2017 to 9.11.2018. Vertical dashed line indicates the end of volatility calibration period. Option prices are calculated based on the volatility and the stock’s price on 3.08.2018.

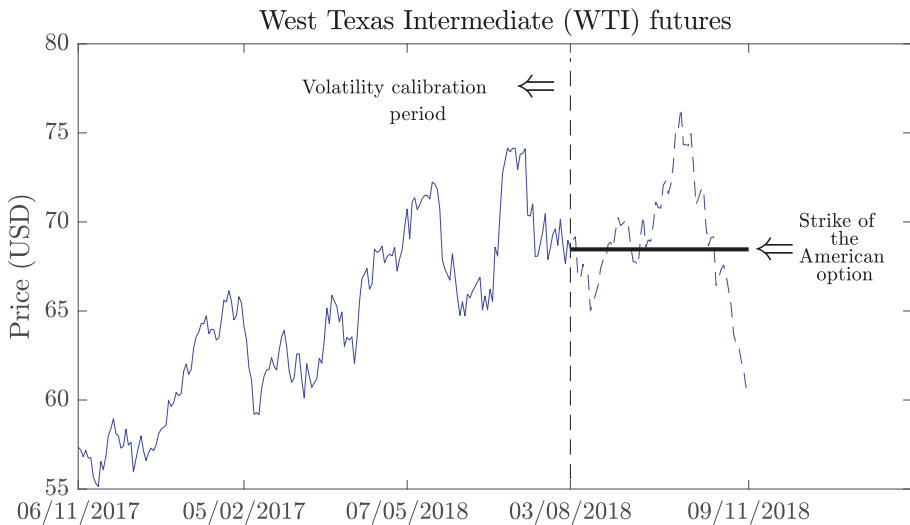

Figure 9. Daily closing prices of the West Texas Intermediate crude oil futures contracts. Data spans from 6.11.2017 to 9.11.2018. Vertical dashed line indicates the end of volatility calibration period. Option prices are calculated based on the volatility and the asset’s price on 3.08.2018.

Since the payoff of π -option on relative drawdown with $K = 1$ is always less than 1, to compensate against the drop in underlying’s price, we need a certain number of these contracts per each unit of stock in our portfolio. This number must be equal to M_0 . Please note that in Tables 4 and 5, the real price of the single π -option on relative drawdown contract should be 0.0735 for MSFT and 0.0949 for WTI. However, in order to be able to compare the results to the American put values, we initially need to make the instruments pay the same amount in case of a price drop, therefore we multiply the price of single π -option on drawdown by M_0 (110 and 74 for MSFT and WTI respectively). That is why in

Tables 4 and 5 the price of π -option equals $0.0735 \cdot 110 = 8.09$ for the stock and $0.094 \cdot 74 = 6.95$ for the oil futures contract.

Table 4. Input parameters for computation and estimated options' prices for the MSFT dataset.

MSFT			
American Put		π on Drawdown	
Parameter	Value	Parameter	Value
K	108.13	M_0	110.83
S_0			108.13
σ			24.06%
r			2.25%
l			100
T			3
Option price			
\$5.47		\$8.09	

Table 5. Input parameters for computation and estimated options' prices for the WTI dataset.

WTI			
American Put		π on Drawdown	
Parameter	Value	Parameter	Value
K	68.49	M_0	74.15
S_0			68.49
σ			23.97%
r			2.25%
l			100
T			3
Option price			
\$3.07		\$6.95	

It turns out that π -option is more expensive than vanilla put in case of both assets, which is not a surprise as it initially pays the amount equivalent to the present maximum drawdown. However, since the difference in price between these instruments is rather significant, a question emerges whether there exists a situation in which purchasing π -option on relative drawdown is more profitable than buying a simple vanilla put. To answer this question, let us focus on the dashed part of the Microsoft Corporation and WTI futures data from the beginning of this section. In Figures 10 and 11 we show the amount each instrument would pay (on each day) throughout the whole 3-month period until options' maturity.

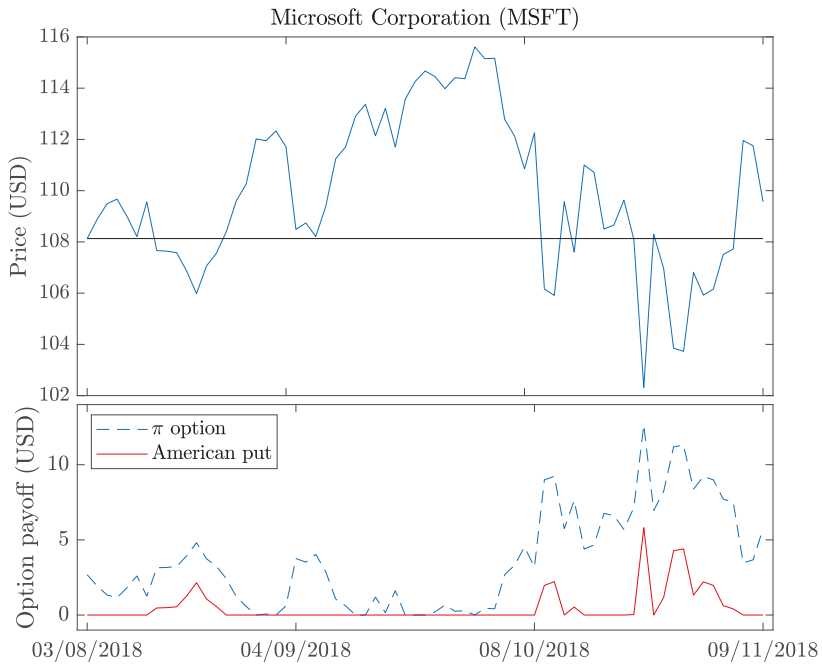

Figure 10. Microsoft Corporation stock closing prices (top) and the corresponding payoffs of π -option on relative drawdown and American put (bottom) with the parameters from Table 4.

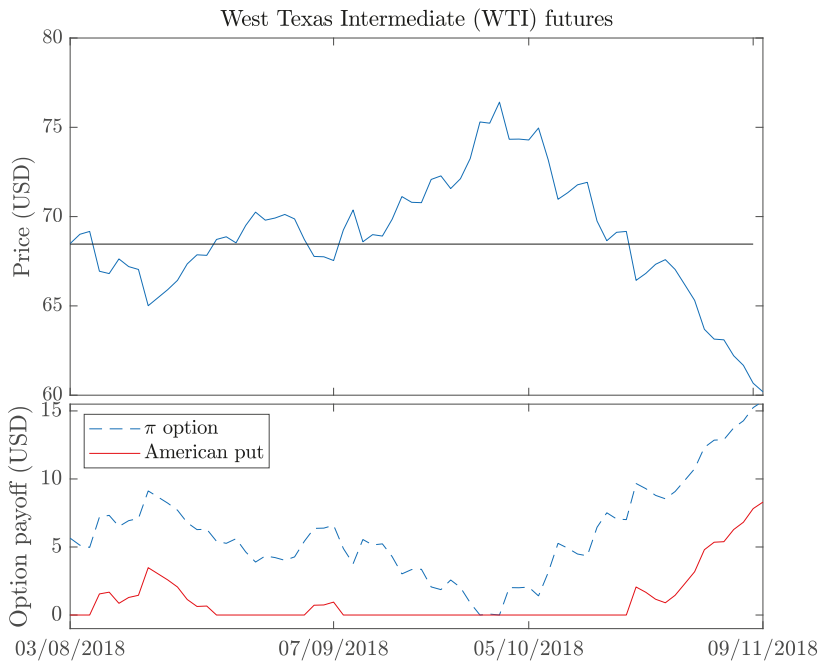

Figure 11. WTI crude oil futures contract closing prices (top) and the corresponding payoffs of π -option on relative drawdown and American put (bottom) with the parameters from Table 5.

To display the difference more clearly, we construct two portfolios V_{American} and V_{π} , both consisting of an underlying asset (a single Microsoft Corporation stock or a barrel of the WTI crude oil) and an option (American put and π -option on relative drawdown, respectively). We observe them at the end of the volatility calibration period. Assets' prices and options prices are taken from Tables 4 and 5. In Tables 6 and 7 we show the initial net values of both V_{American} and V_{π} portfolios.

Table 6. Portfolios and their initial net values for the MSFT dataset.

Portfolio	V_{American}	V_{π}
Initial asset value	108.13	108.13
Option premium	−\$5.47	−\$8.09
Option initial payoff	\$0	\$2.68
Portfolio's net value	\$102.66	\$102.72

Table 7. Portfolios and their initial net values for the WTI dataset.

Portfolio	V_{American}	V_{π}
Initial asset value	68.49	68.49
Option premium	−\$3.07	−\$6.95
Option initial payoff	\$0	\$5.66
Portfolio's net value	\$65.42	\$67.20

Then we analyze the behavior of the constructed portfolios, by calculating the net value of each portfolio for each day until options' maturity; see Figures 12 and 13.

Based in Figures 12 and 13 we can observe that the maximum value of portfolio V_{American} is greater than the one for V_{π} . Thus, when focusing purely at the possible maximum profit over some period of time, then the portfolio containing American option performs better. However, we can notice that V_{American} 's value over time is much more volatile compared to V_{π} and it directly follows the behavior of underlying asset (it increases when asset's price rises and decreases in the opposite situation). The value V_{π} of π -option portfolio is most of the time non-decreasing. Moreover, V_{π} increases its value every time the asset's price reaches a new maximum and essentially does not decrease in case of any price drop. In other words, combining the underlying asset and π -option on drawdown allow us to lock in our profit whenever the price reaches its new maximum.

This brings us to the conclusion that the purpose of using π -option on relative drawdown and an American put is completely different. Vanilla American option protects us from asset price drops and ensures us that the current worth of our portfolio will not be less than its initial value. Unfortunately, in this case our portfolio's value is more volatile and reflects the volatility of the underlying asset. This may result in bigger gains when compared to the use of π -option on relative drawdown if the price of the underlying rises significantly and stays on that level until option's maturity. However, in case of a drop in asset price after the upswing, we do not benefit from the fact that the new maximum has been reached and thus the value of our portfolio decreases together with the price of the underlying asset. When looking at the value of V_{π} over time one can notice that combining stock or a commodity and π -option on relative drawdown protects us against price drops as well but the volatility of our portfolio is reduced significantly. Additionally, the contract allows us to benefit from the underlying's price upswings and locks in the profit every time new maximum is reached.

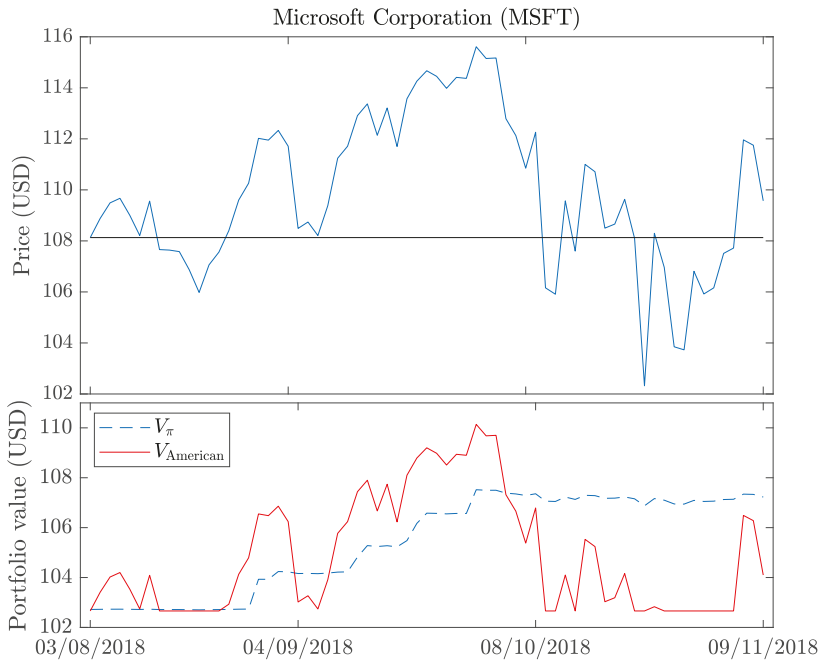

Figure 12. Microsoft Corporation stock closing prices (**top**) and payoffs of portfolios with parameters from Table 4 (**bottom**).

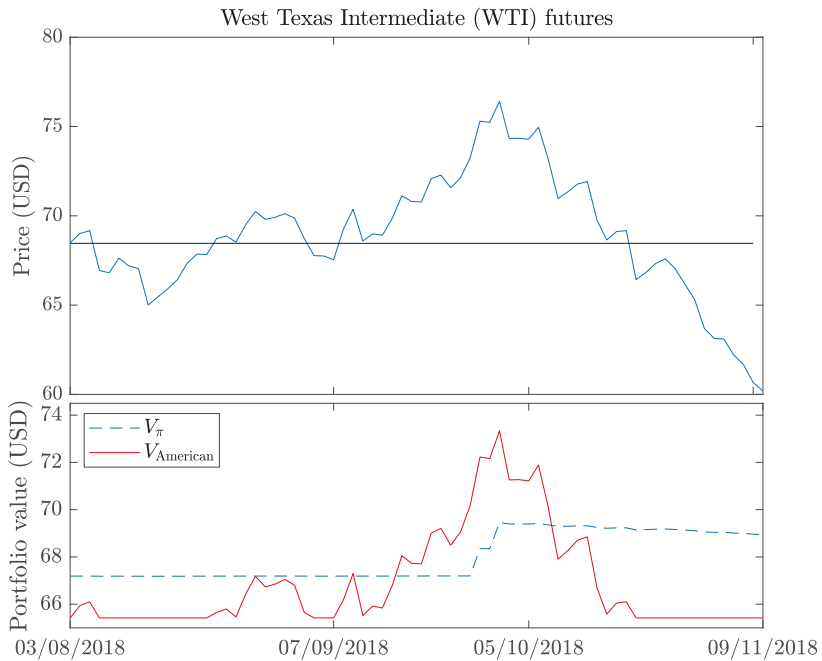

Figure 13. WTI crude oil futures contract closing prices (**top**) and payoffs of portfolios with parameters from Table 5 (**bottom**).

We have analyzed two datasets, MSFT and WTI, and the above analysis shows that the behavior of a portfolio based on π -option is similar for various choices of underlying assets.

4. Conclusions

In this paper we focus on the numerical pricing of the new derivative instrument—a π -option. We adapted the Monte Carlo algorithm proposed by Broadie and Glasserman (1997) to price this new option. We focused on a specific parametrization of this option which we call the π -option on drawdown. We observed that this specific financial instrument is related to so-called relative maximum drawdown. We obtained prices of the π -option on relative drawdown for the Microsoft Corporation stock with different parameters to examine the influence of those parameters on option's premium. Our next step involved the analysis of two portfolios: first one based on a π -option on relative drawdown and the second one based on an American put. We used the Microsoft Corporation data as well as the West Texas Intermediate crude oil futures dataset. It turned out that the portfolios behave in a completely different manner. The value of the portfolio containing the American put was highly correlated with the underlying's price movements and thus had an unpredictable and volatile behavior. On the other hand, combining π -option on relative drawdown with the underlying asset not only ensures that the worth of the portfolio will not drop below the initial level, but it also allows us to take advantage of price upswings and to reduce the portfolio's volatility at the same time. Similar analysis could be carried out for a geometric Lévy process of asset price. One can also consider the regime-switching market.

Author Contributions: Methodology, Z.P. and T.S.; Formal Analysis, Z.P., T.S.; Investigation, Z.P. and T.S.; Writing—Original Draft Preparation, T.S.; Writing—Review and Editing, Z.P.; Visualization, T.S.; Supervision, Z.P.; Project Administration, Z.P.; Funding Acquisition, Z.P. All authors have read and agreed to the published version of the manuscript.

Funding: This paper is supported by the National Science Centre under the grant 2016/23/B/HS4/00566 (2017–2020).

Conflicts of Interest: The funders had no role in the design of the study; in the collection, analyses, or interpretation of data; in the writing of the manuscript, or in the decision to publish the results.

References

- Barraquand, Jérôme, and Didier Martineau. 1995. Numerical valuation of high dimensional multivariate American securities. *Journal of Financial and Quantitative Analysis* 30: 383–405. [\[CrossRef\]](#)
- Brennan, Michael J., and Eduardo S. Schwartz. 1978. Finite Difference Method and Jump Processes Arising in the Pricing of Contingent Claims. *Journal of Financial and Quantitative Analysis* 13: 461–74. [\[CrossRef\]](#)
- Boyle, Phelim P. 1977. Options: A Monte Carlo approach. *Journal of Financial Economics* 4: 323–38. [\[CrossRef\]](#)
- Boyle, Phelim, Mark Broadie, and Paul Glasserman. 1997. Monte Carlo Methods for Security Pricing. *Journal of Economic Dynamics and Control* 21: 1267–321. [\[CrossRef\]](#)
- Broadie, Mark, and Jerome Detemple. 1996. American Option Valuation, New Bounds, Approximations, and a Comparison of Existing Methods. *Review of Financial Studies* 9: 1211–50. [\[CrossRef\]](#)
- Broadie, Mark, and Paul Glasserman. 1997. Pricing American-style securities using simulation. *Journal of Economic Dynamics and Control* 21: 1323–52. [\[CrossRef\]](#)
- Broadie, Mark, Paul Glasserman, and Gautam Jain. 1997. Enhanced Monte Carlo estimates for American option prices. *Journal of Derivatives* 5: 25–44. [\[CrossRef\]](#)
- Caflich, Russel E. 1998. Monte Carlo, and Quasi-Monte Carlo Methods. *Acta Numerica* 7: 1–49. [\[CrossRef\]](#)
- Carr, Peter, and Dmitri Faguet. 1994. *Fast Accurate Valuation of American Options*. Working Paper. Ithaca: Cornell University.
- Carriere, Jacques F. 1996. Valuation of the early-exercise price for options using simulations and nonparametric regression. *Insurance: Mathematics Economics* 19: 19–30. [\[CrossRef\]](#)
- Christensen, Sören. 2013. Contributions to the Theory of Optimal Stopping. Ph.D. dissertation, Christian-Albrechts Universität Kiel, Kiel, Germany.
- Clément, Emmanuelle, Damien Lamberton, and Philip Protter. 2002. An Analysis of a Least Squares Regression Method for American Option Pricing. *Finance and Stochastics* 6: 449–71. [\[CrossRef\]](#)

- Dyer, Lawrence, and David Jacob. 1991. An Overview of Fixed Income Option Models. In *The Handbook of Fixed Income Securities*. Edited by Frank Fabozzi. Homewood: Business One Irwin, pp. 742–73.
- Egamim, Masahiko, and Tadao Oryu. 2017. A direct solution method for pricing options involving the maximum process. *Finance and Stochastics* 21: 967–93. [CrossRef]
- Geske, Robert, and Kuldeep Shastri. 1985. Valuation by Approximation: A Comparison of Alternative Option Valuation Techniques. *Journal of Financial and Quantitative Analysis* 20: 45–71. [CrossRef]
- Glasserman, Paul. 2004. *Monte Carlo Methods in Financial Engineering*. New York: Springer.
- Guo, Xin, and Mihail Zervos. 2010. π options. *Stochastic Processes and their Applications* 120: 1033–59. [CrossRef]
- Jäckel, Peter. 2002. *Monte Carlo Methods in Finance*. Chichester: John Wiley.
- Joy, Corwin, Phelim P. Boyle, and Ken Seng Tan. 1996. Quasi-Monte Carlo methods in numerical finance. *Management Science* 42: 926–38. [CrossRef]
- Longstaff, Francis A., and Eduardo S. Schwartz. 2001. Valuing American options by simulation: A simple least-squares approach. *Review of Financial Studies* 14: 113–47. [CrossRef]
- Niederreiter, Harald. 1992. *Random Number Generation and Quasi-Monte Carlo Methods*. Vienna: Society for Industrial and Applied Mathematics.
- Raymar, Steven B., and Michael J. Zwecher. 1997. A Monte Carlo valuation of American call options on the maximum of several stocks. *Journal of Derivatives* 5: 7–23. [CrossRef]
- Rogers, Leonard C.G. 2002. Monte Carlo Valuation of American Options. *Mathematical Finance* 12: 271–86. [CrossRef]
- Schwartz, Eduardo S. 1977. The Valuation of Warrants: Implementing a New Approach. *Journal of Financial Economics* 4: 79–93. [CrossRef]
- Stentoft, Lars. 2004a. Convergence of the Least Squares Monte Carlo Approach to American Option Valuation. *Management Science* 50: 1193–203. [CrossRef]
- Stentoft, Lars. 2004b. Assessing the Least Squares Monte Carlo Approach to American Option Valuation. *Review of Derivatives Research* 7: 129–68. [CrossRef]
- Tilley, James A. 1993. Valuing American Options in a Path simulation model. *Transactions of the Society of Actuaries* 15: 499–550.
- Tsitsiklis, John N., and Benjamin Van Roy. 1999. Optimal stopping of Markov processes: Hilbert space theory, approximation algorithms, and an application to pricing high-dimensional financial derivatives. *IEEE Transactions on Automatic Control* 44: 1840–51. [CrossRef]
- Tsitsiklis, John N., and Benjamin Van Roy. 2001. Regression methods for pricing complex American-style options. *IEEE Transactions on Neural Networks* 12: 694–703. [CrossRef]
- van Resenburger, Janse, and Glenn Torrie. 1993. Estimation of multidimensional integrals: Is Monte Carlo the best method? *Journal of Physics A: Mathematics and General* 26: 943.
- Villani, Giovanni. 2010. A Monte Carlo approach to value exchange options using a single stochastic factor. In *Mathematical and Statistical Methods for Actuarial Sciences and Finance*. Edited by Ballester Ferrer and Corazza Pizzi. Milan: Springer, pp. 305–31.
- Zhao, Jinsha. 2018. American Option Valuation Methods. *International Journal of Economics and Finance* 10: 1. [CrossRef]



© 2020 by the authors. Licensee MDPI, Basel, Switzerland. This article is an open access article distributed under the terms and conditions of the Creative Commons Attribution (CC BY) license (<http://creativecommons.org/licenses/by/4.0/>).

Article

Determining Economic Security of a Business Based on Valuation of Intangible Assets according to the International Valuation Standards (IVS)

Dmitrii Rodionov, Olesya Perepechko and Olga Nadezhina *

Graduate School of Industrial Economics, Peter the Great St. Petersburg Polytechnic University, 195251 Saint-Petersburg, Russia; rodionov_dm@spbstu.ru (D.R.); po.olesya9@gmail.com (O.P.)

* Correspondence: nadezhina_os@spbstu.ru; Tel.: +7-911-252-8637

Received: 25 August 2020; Accepted: 8 October 2020; Published: 20 October 2020

Abstract: This work considered the economic security of an enterprise with regard to the valuation of intangible assets according to the International Valuation Standards (IVS). This study is essential due to a growing number of companies with intangible assets (trademarks, patents, know-how, etc.) as their main value. This study included analysis of the impact created by the value of intangible assets and intellectual property on company capitalization and economic security plus a regression model. An algorithm was developed to determine the economic security of a business based on the valuation of intangible assets according to the IVS. The suggested algorithm can allow a company to manage its intangible assets effectively using the IVS, which, in turn, will provide the required level of economic security for further development and achievement of strategic goals by the business entity.

Keywords: economic security of companies; valuation of intangible assets and intellectual property; International Valuation Standards (IVS); legal disputes over intellectual rights

1. Introduction

The issues of providing business entities with economic security in a time when multiple internal and external threats are being faced are of top priority today. According to the World Intellectual Property Organization (WIPO), intellectual property accounts for over 75% of all earnings in the world economy ([World Intellectual Property Organization 2017](#)).

Companies are always investing in intangible assets and intellectual property in attempts to outrun their competitors ([World Intellectual Property Organization 2017](#)).

A considerable growth in the number of cases on the rights for intangible assets and intellectual property heard by the Court of Intellectual Rights of the Russian Federation is evidence of growing losses caused by the violation of rights in this sphere. According to the latest survey of the cases related to settling disputes on intellectual rights, 742 cases of this category were considered in 2018 in Russia, with 710 of them being about providing or terminating legal protection of the results of intellectual activity and means of identification. The growth rates as of the first six month of 2019 amounted to 14.5% against the same period of the previous year ([Superior Court of Arbitration 2018](#)).

According to the statistics of the United States District Courts, the total number of cases on copyright, patents, or trademarks was 12,268 in 2019, while in 1990 the number of cases was 5700 ([Courts 2019](#)).

This is due to the fact that the internal structure of economic security of any business entity includes three primary components: economic independence, economic resilience and self-development ([Radyukova and Shamaev 2011](#)).

At present, there are many different approaches that are based on the assessment of individual components of the security of a company's activities, and there is no structured methodology that includes intangible assets and intellectual property.

The purpose of the study was to develop an algorithm to determine the economic security of businesses based on valuation of intangible assets in accordance with the IVS.

In order to accomplish the purpose of the study, the following objectives were set:

- Based on literature review, to define the position of intangible assets in the activities of economic entities and the availability of approaches that can be used to assess the impact of intangible assets and intellectual property on economic security of companies;
- To consider the impact produced by intangible assets on the value and economic security of business entities;
- To develop methodology to determine the economic security of a business based on the valuation of intangible assets using the IVS.

The paper is structured as follows: literature review, description of the applied models and methods, substantiation of the applied data, specification of the research results and reliability analysis of the calculated research results. The paper also details an algorithm for determining the economic security of businesses based on the valuation of intangible assets according to the IVS, along with discussion of the results and conclusion.

2. Literature Review

A universal algorithm for determining the economic security of enterprises based on intellectual property has not been developed so far. Starting from the 1980s, foreign scholars conducted major scientific research on the whole range of questions related to the role of intellectual capital for business development. They note a considerable effect produced by intangible assets on company security (Barth et al. 2001). American economists V. Andonova and Ruiz-Pava highlight that companies are highly dependent on their intangible assets. The authors also conclude that intangible assets are a major factor in the productivity of enterprises and determine their competitive advantages in the external environment (Andonova and Guillermo 2016). According to the International Valuation Standards 2020, section IVS 210, an intangible asset is defined as: "a non-monetary asset that manifests itself by its economic properties. It does not have physical substance but grants rights and/or economic benefits to its owner".

Tsai et al. (2016) present a study that is based on comparison of various types of machine learning for intangible assets. Clausen and Hirth (2016) in their work introduce a profit indicator, related to the value of intangible assets based on the productivity of intangible assets. Gu and Li (2015) in their study investigate the matters related to investing in companies based on intangible assets. Vasconcelos et al. (2019) presented work aimed at studying the relationship between the intangible assets, macroeconomic environment and market value of public companies in Germany, the UK and Portugal. They also investigated the impact of intangible assets on the market value of companies using sensitivity tests. In their research, the authors Montresor and Vezzani (2016) highlight the innovative impact of intangible investments and claim that via intangible investments companies acquire knowledge assets that increase their innovativeness. Matos et al. (2018) formulated a hypothesis that future results of many companies will depend on intangible assets. They carried out analysis of intangible assets for a number of European Union countries.

The research by Basso et al. (2015) shows the contribution of intangible assets in the creation of the value of companies using the methodology suggested by Gu and Li.

In his research, Nejati (2016) explains the main components of intangible assets, namely human capital, structural capital and relational capital.

Russell (2016) considers the intangible assets of pharmaceutical companies and compares the value of these assets in terms of their significance.

In their research, Pastor et al. (2017), Bontis (2001), Bouteiller and Karyotis (2010) and Pastor et al. (2017) carried out analysis and review of the literature dedicated to intangible assets and their valuation as well as the examples of methods that can be used to evaluate individual intangible assets. The work by Plaskova et al. (2019) carried out analysis, based on which a clear definition of an innovative asset as an element of an organization's intangible assets was given. Proposals were made to create a solid business image and investment attractiveness of an organization. Authors Boj et al. (2014) look at intangible assets and intellectual capital as the key drivers creating value and competitive advantages for organizations (Rodionov et al. 2018a) They suggest methodology for defining, measuring and managing the relevance of intangible assets in achieving the strategic goals of an organization (Bouteiller and Karyotis 2010).

In the method described by Kaplan and Norton (2004), a firm initiates the most important processes and determines human, information and organizational capital necessary for these processes (Rodionov et al. 2018b).

Del Giudice and Paola (2017) consider intangible assets and intellectual property from the perspective of the fact that they ensure competitiveness, prosperity and growth of the enterprise.

Based on the literature review it can be concluded that the issues concerning the impact created by intangible assets on economic security of companies have not been extensively studied to date. Moreover, not enough attention is paid to economic security on the basis of intangible assets.

According to the data presented in the survey conducted by Brand Finance GIFT, the Top 100 Companies by Total Intangible Value, among 100 large companies, more than 50 have intangible assets exceeding 90% of the value of the entire business. Examples of these companies are Johnson & Johnson, Visa Inc., The Procter & Gamble Co., Anheuser-Busch InBev., Comcast Corp., Mastercard Inc., Novartis AG, Amazon.com Inc., and Microsoft Corp. (Brand Finance 2019). Thus, many business entities carry out their activities only because they have trademarks, patents, new technologies, intangible assets and intellectual property (Chernogorsky 2018).

Accordingly, new R&D, advanced technologies and know-how are becoming more and more actively involved in business processes, which increases the importance of intellectual property and intangible assets, so determining economic security in this field is becoming increasingly important. At the same time, it was observed that to date no algorithm has been developed for determining the economic security of a business based on valuation of intangible assets in accordance with the IVS.

At present, there are many different approaches that are based on the assessment of individual components of the security of a company's activities.

In addition, it should be noted that the presented approaches do not have a structured methodology. Some proposed methods have the following disadvantages:

- There is no possibility of practical implementation due to the absence of assessment criteria or an established scale of values;
- There is no approach to assessing business security that would take into account all the components of the economic security of an enterprise;
- The assessment of the company's security is based only on the threats or risks of its implementation;
- Underestimation of the impact of intangible assets on the economic security of companies.

Accordingly, a distinctive feature of this study is the special attention paid to intangible assets and intellectual property and their impact on the economic security of companies.

3. Models and Methods

In the course of the study, we identified the parameters that could be used to judge the factors that affect the value and economic security of business entities.

The indicators of companies that are not interdependent act as factor characteristics, X. These characteristics include revenue, intangible assets, intellectual property, fixed assets, assets under construction, financial investments, current assets and long-term and short-term liabilities.

Capitalization or the value of business entities (the resulting characteristic, Y) is understood as the product of the market value of one company's share (share price) and the number of shares in circulation.

The imbedded Excel package "Data Analysis" and statistics data analysis package "Stata" were used for modeling.

In the course of the study it was established that there is a ratio between the resulting indicator and variables. Its direction was defined, as well as the correlation ratio and adequacy of the model obtained, which implies the degree to which the theoretical model that was built to describe the relationship between the characteristics reflects the actual dependence between these characteristics, i.e., whether the model is practically admissible.

In order to check the presence of heteroscedasticity of random errors in the regression model obtained according to the initial values of the characteristics in logarithmic form, the White test was used. The test is based on checking a time series for heteroscedasticity.

An important accompanying problem is to verify the causal link between the time series of the factor and resulting characteristic, which was settled using the Granger causality test. The test can be used to answer the question: Is it true that change in the value of intangible assets and intellectual property (X) will entail change in the company capitalization (Y)? It was checked using a linear regression model of Y values on previous X and Y values.

In other words, Y values are presented in the following form:

$$Y_i = u_i + \sum a_k y_{i-k} + \sum b_k x_{i-k} + E_i \quad (1)$$

Y_i is the value of variable Y at time i ;

X_i is the value of variable X at time i ;

k is the time delay (in our case, a lag).

If in the regression obtained coefficients k of the formula can be neglected, it is believed that the previous X values do not help to predict Y and, consequently, X is not the cause of Y according to the Granger causality test.

Based on the model obtained, an algorithm determining the economic security of businesses was suggested. The uniqueness of the algorithm is in the fact that it unites all the basic functions of intangible assets and intellectual property that provide economic security. In addition, the algorithm is versatile and can be used by companies operating in different industries.

4. Data

The largest companies were chosen as objects of the research, since they are clearly indicative representatives of the oil industry among Russian companies whose shares are listed on the stock market and that represent 90% of the market in the sector.

The analytical data posted on the official websites of Russian organizations formed the information basis for the research. The financial and economic indicators of the Russian companies whose shares are listed on the OJSC Moscow Stock Exchange and the Russian Trading System (RTS) were the empirical basis of the research.

In addition, the totality of indicators was determined from the existing indicators of the financial statements of the business entities over the last seven years for each company operating in the oil sector.

5. Results

The results of the calculations and the regression model built for the oil industry are presented below.

5.1. Adequacy Analysis of the Calculated Research Results

The indicators of companies, which are not interdependent among themselves, are used as factor signs “ x ”. These features are revenue, intangible assets, intellectual property, fixed assets, construction in progress, financial investments, current assets and long-term and short-term liabilities. By capitalization or the value of business entities (resultant attribute “ Y ”) we mean the market value of one share of the company (share price) per the number of shares in circulation. Data from financial statements for the last five years were used for calculations. For this study, annual data were used.

The tightness of the relationship between linearly dependent features was determined using a linear correlation coefficient (r), the calculation of which is automated using statistical data analysis packages. The linear model of pair regression between the value of intangible assets and company capitalization has the following form:

$$Y = -1.946987x_1 + 307.4673x_2 - 0.4629237x_3 - 2.445406x_4 - 0.4796452x_5 + 6.288961x_6 - 0.1429317x_7 - 103000000 \quad (2)$$

The regression coefficient under x shows that if the value of intangible assets and intellectual property increases, the market capitalization of the company increases too. Input data for the computational model are presented in Appendix A.

The model was checked for adequacy. The results presented in the Tables 1–4.

Table 1. Regression analysis data of the relationship between the value of intangible assets (x_2) and the capitalization of Russian companies.

Source	Coefficient	Std. Error	t-Ratio	p-Value ($p > t$)
const	307.4673	52.09164	5.90	0.004
l_int_rus	-1.03000000	5.4900000	-1.88	0.134

Thus, the result of 0.004 means that the hypothesis is confirmed as the result was less than 0.134.

Table 2. Regression analysis data of the relationship between the value of intangible assets and the capitalization of Russian companies.

Sum Squared Resid	43,566,000,000,000,000		
R-squared	0.9971	Adjusted R-squared	0.9922
F(7, 6)	113.93	p-value (F)	0.0001

Since the significance level ap (p -value), calculated for coefficients a_0 and a_1 is lower than the set significance level $a = 0.01$, both these coefficients are recognized as non-random (i.e., typical for the general population).

The value of the determination index R^2 (R-squared in the table) is equally 0.9971. This value is over 0.5, which is evidence of the good approximation of the source (actual) data using the built linear function of relation.

Table 3. The regression output p -value of each variable.

Source	$p > t $
x1	0.007
x2	0.004
x3	0.073
x4	0.095
x5	0.436
x6	0.001
x7	0.828
_cons	0.134

The adequacy of the regression model to the actual data was also established by Fisher's ratio test, which evaluates the statistical significance (non-randomness) of the determination index as typical, so the linear model of relation between characteristics X and Y is to a greater degree applicable to the general population of enterprises as a whole. Then, a heteroscedasticity test was used. The presence of heteroscedasticity leads to the following negative effects: the estimations of the standard errors of regression coefficients are displaced, the estimations of regression coefficients using the method of least squares are ineffective and *t*-statistics of regression coefficients are inadequate.

Table 4. The results of the heteroscedasticity test.

Source	chi2	df	<i>p</i>
Heteroscedasticity	12.00	11	0.3636
Skewness		7	
Kurtosis		1	
Total		19	

As a result of the test, it was revealed that in the majority of cases heteroscedasticity is satisfactory, so general statistical methods can be used.

According to the results of the test, it was concluded that the *p*-value is higher than the significance level chosen as 5% ($0.3336 > 0.05$), so hypothesis zero about the lack of heteroscedasticity was not rejected, i.e., the random disturbance dispersion does not depend on X and the regression model (3) detailed above is homoscedastic. This proves the adequacy of the statistical valuations of the quality of the linear regression model. Calculations were made according to the Granger test for the period from 2013 to 2019 with the time lag being 1.

To study the directions of the causal relationships between the intangible assets and capitalization, the Granger test was used, where x_1 is the intangible assets of the company. If it is > 0.05 , it cannot be claimed that the hypothesis "A is NOT the Granger cause of B" is true. Thus, capitalization is dependent on intangible assets, since the coefficient is 0.224 and 0.997.

Typically, the Granger test tests two null hypotheses: "x is not the cause of y by Granger" and "(Y is not the cause of X by Granger)". The *p*-values are small, so we accept the hypothesis that X1 is the Granger cause of Y1. Further, when the situation is reversed, *p*-values are greater than 0.05; therefore, we reject the hypothesis that Y1 is the Granger cause for X1.

According to the above information it can be concluded that despite industry specific features, which affect the quantitative values of intangible assets and intellectual property, the value of business entities and their level of economic security are affected.

5.2. Algorithm to Determine Economic Security of a Business Based on Valuation of Intangible Assets According to the IVS

According to the results of the study, an algorithm was developed to determine the economic security of businesses. This algorithm is based on a multi-stage comprehensive analysis of intangible assets and intellectual property.

As an example, one of the large oil companies represented on the Russian market was considered. At the first stage the company performance was preliminarily analyzed considering the specifics of the sector where it operates. The performance analysis was carried out on the example of the Neft Y company, for which indicators for the period 2017–2019 were analyzed. The main indicators of the financial status and performance of Neft Y were selected and grouped according to the qualitative characteristics in the period analyzed.

The company performance is defined by the following indicators:

- The net assets exceed the equity capital, and an increase in the net assets was observed during the analyzed period;

- A positive change in the organization's own capital in relation to the total change in the organization's assets;
- A growth in revenue by 94.4% was observed during the analyzed period;
- The share of self-cost in revenue was 91.08–93.49 % during the analyzed period;
- Profits grew by 49% during the analyzed period, and net profit was obtained (2,366,408 thousand rubles);
- A growth in fixed assets and intangible assets was observed;
- Borrowed money is actively used in the company's operations.

Based on the above analysis, it can be concluded that positive dynamics of the main indicators (revenue, net profit) are observed in the performance of Neft Y. The company actively involves intangible assets in its operations.

At the second stage, more profound analysis of the indicators was carried out.

Firstly, in Block 1 we analyzed the existing intangible assets, including the rights for the results of intellectual activity that are not accounted for in books, as well as the efficiency of the intangible assets management system of the business entity. According to the conducted analysis, Neft Y has the following intangible assets: a license for exploration and production of raw hydrocarbons and a patent. Thus, intangible assets are applied in the operations of the company, which allows it to use new technologies and explore deposits for producing raw hydrocarbons.

In Block 2, investments were calculated.

In this block, investments in intangible assets and intellectual property were calculated. The value of intangible assets and intellectual property was calculated according to the IVS to achieve a high quality of calculations along with transparency and reliability. Since Neft Y acquired a new license for exploration and production of raw hydrocarbons, the value of the required investments was estimated, as detailed in Section 5.

In Block 3 the sources of the effect were analyzed.

In order to determine the source of the effect (benefits, profits) from using intangible assets and intellectual property, it is important to carry out a comprehensive study, which represents a legal and engineering study.

The legal study includes defining the title documents based on which the rights for intellectual property are vested.

In the engineering study, the quantitative and qualitative technological and engineering characteristics and parameters of the goods produced due to the presence of intellectual property are established.

When the sources of the effect were analyzed, the following intangible assets were identified for Neft Y: a license for exploration and production of raw hydrocarbons and a patent for a gravel filter. The patent is a title document. The invention is specific to the oil and gas industry and can be used to install gravel filters and to overhaul boreholes. The validity period of the patent is 20 years. Neft Y has a registered trademark, which is not accounted for in books. Thus, the trademark of Neft Y can be accounted for in books according to the market value.

Stage 3.1. Using intangible assets in business activities (calculating the annual income from using them). In this case it is assumed that the business entity is the holder of exclusive rights due to which the business entity has a right to produce unique goods and services.

Stage 3.2. Using intangible assets in commercial turnover, license for intangible assets. According to the license contract, the holder of the exclusive right (licensor) grants the other party (licensee) the right to use the intellectual property. The transfer of non-exclusive rights is another source of income from applying intellectual property.

Neft Y has not made license contracts so far but plans to consider the possibility of granting non-exclusive rights for the use of the patent for the gravel filter.

Stage 3.3. Using intangible assets when exclusive rights belong to three parties. In this case the business entity uses intangible assets in its activities that belong to the right of use of a non-exclusive

license. Prior to making a license contract, a feasibility study has to be conducted to make sure it is reasonable to conclude this contract and to adequately calculate the price of the right of use.

Neft Y lacks such contracts, so no analysis was performed at this stage.

Stage 3.4. Using intangible assets as a collateral for attracting investments.

A mandatory condition for collateral is the state registration of the above list of assets. In order to obtain the collateral, the market value of the asset has to be defined. In this case, special attention must be paid to the quality of the valuation report, which will be used as a basis for taking a decision about the collateral. It is the IVS that ensure the quality, transparency, fairness and reliability of the valuation. This is extremely important for taking investment decisions and for the purposes of collateral. The registered trademark and the patent for the gravel filter can be the subject of collateral for the Neft Y company.

Stage 3.5. Using intangible assets to make a payment in the business entity's equity capital.

Exclusive rights for intangible assets can be introduced into the company's equity capital. All intangible assets are introduced into the equity capital of the business entity at market value calculated in the valuation report that is prepared according to the IVS. Increasing the equity capital helps to attract investments for the activities of the company.

In Block 4 the current expenses of the business entity were analyzed.

Stage 4.1. Analysis and calculation of patent taxes to maintain the patent in force.

Stage 4.2. Tax analysis and calculation.

Periodic (current) payments for the use of rights for the results of intellectual activity and rights for individualization means (in particular, the rights emerging from patents for inventions, useful models, industrial samples) are included in the composition of the company's expenses. Thus, due to an increase in expenses, the size of the profit tax goes down.

In addition to the income obtained by business entities due to intangible assets, it is reasonable to account for the tax benefits for the rights holder.

Tax benefits include reduction in the amounts of taxes and an effective increase in the cash flow of the business entity. For some objectives of valuation, such as financial statements, the tax benefit from depreciation should be included in the valuation when applying the income approach to intangible assets ([International Valuation Standards 2020](#)).

Thus, intangible assets give the company real tax benefits due to depreciation, which is in many tax jurisdictions. The calculation of results are presented in the Table 5.

Table 5. The profit tax calculated prior to and after the intangible assets were accounted for and depreciated.

Item	2019 (without Accounting for the License for Intangible Assets)	2019 (Accounting for the License for Intangible Assets)
Revenue from selling goods, products, work and services (in current prices), thousand rubles	41,785,958	41,785,958
Full self-cost of sold goods, work, services, thousand rubles	38,666,550	38,761,413
Depreciation of fixed assets	118,266	118,266
Depreciation of intangible assets	50	94,913
Earnings before interest and tax (EBIT)	2,958,010	2,863,147
Profit tax, thousand rubles	591,602	572,629
Difference in profit tax for one year including and excluding the depreciation of intangible assets, thousand rubles		18,973

Compiled by the authors.

Thus, the profit tax due to the depreciation of the business entity's intangible assets can be 18,973 thousand rubles lower per year.

Stage 4.3. Analyzing and calculating royalty fees.

The company paying royalty fees to the authors for using intellectual property is one of the most important issues. Royalty fees were not calculated in this study because the company lacks patents wherein the authors have the right to receive royalty fees.

Stage 4.4. Analyzing and calculating payments under license contracts.

Payments under license contracts can be defined by one of the following options: royalties (payments represent a percentage of the licensee's revenue from the products sold), a lump sum payment (a single payment, which represents a fixed amount) and a combined payment (part of the amount is paid in one installment, and the second part represents payments in form of royalties).

Stage 4.5. Expenses related to risks in the sphere of intellectual rights (legal expenses).

Legal expenses in the sphere of patent disputes can amount to substantial costs that business entities bear in case of litigation. These expenses arise if legal disputes are dealt with.

Stage 4.6. Expenses related to loan payments in case intangible assets are used as collateral.

In this case, expenses related to payment interest on loans arise only if the business entity has a loan and occur according to the terms of the contract.

In Block 5 the value of the effect was calculated.

The effect from intangible assets and intellectual property can be expressed in the ways described below.

Stage 5.1. Calculating the market value of intangible assets. The market value of the asset is determined according to the IVS. The calculation of the market value of the license for production of raw hydrocarbons is presented as an example in Section 6 and Table 7.

Stage 5.2. Calculating the profits from using intangible assets and intellectual property.

Earnings from the use of intangible assets and intellectual property can be formed by regular royalty payments, depreciation deductions of intangible assets, tax benefits and collateral benefits.

Receiving regular royalty fees is possible in case a license contract is made to transfer non-exclusive right of use of the patent for the gravel filter. In case the license contract is concluded, Neft Y can receive annual income amounting to, on average, 1.91% from the earnings formed with the application of the above patent. Thus, if a medium company in the oil and gas sector applies the patent, it can bring the holder of the exclusive ownership rights 612,350 thousand rubles, on average, with the average earnings being 32,103,215 thousand rubles and the average value of the royalty rate being 1.91%.

Below is given the calculation of the amount of license fee for use of the patent for one year Table 6.

Table 6. The calculated royalty rate (annual payment).

Name	2017	2018	2019
Revenue	21,495,399	33,028,289	41,785,958
Gross profit	1,917,073	2,148,678	3,119,408
Pe = (Gross profit/Revenue), %	8.92%	6.51%	7.47%
The average value of Pe		7.63%	
Licensor's share in the licensee's profit		25%	
Royalty rate $R = D \times \frac{P_e}{1+P_e}$		1.91%	

Compiled by the authors.

6. Valuation of Intangible Assets According to the IVS

In order to implement the algorithm determining the economic security of a business at the investment stage, it is necessary to appraise the investments required for acquiring or creating intellectual property and intangible assets.

The market value of the intellectual property and intangible assets is determined according to the IVS. The IVS are key guidelines for carrying out qualitative valuation all over the world. Applying the IVS gives us a high quality, reliable assessment which is internationally recognized (IVSC 2020).

The market value of the license for the right to produce raw hydrocarbons for Neft Y based on IVS 210 Intangible Assets (IVS 210 Intangible Assets) was calculated using a comparative approach.

According to the IVS, corrections were introduced into the calculations to reflect the specific features of the intangible assets that were evaluated. The method of comparative transactions was used in terms of the comparative approach according to IVS 210 (IVS 210).

In order to estimate the interest discount of Urals oil price to Brent oil price on the markets of Western Europe and the USA, the average level of oil prices for the period 2012 through 2018 was used. The average value according to agency Platts was 1.2%. The average oil prices were according to the source <https://ru.investing.com>.

The average value of the specific indicator of the resource value (price of the license/recoverable resources) was calculated based on the results of the tenders and auctions for obtaining licenses for exploration and production of raw hydrocarbons (www.torgi.gov.ru). The average Urals oil price on the world market as of the tender/auction date was used in the calculations.

After the calculations were made, the corrected value of the stock was 85.957 rub./t. The calculation of results are presented in the Table 7.

Table 7. The results of the calculated market value of the license.

Deposit	The Quantity of Resources by Category C1 as of 30 March 2020, thousand t	The Quantity of Resources by Category C2 as of 30 March 2019, thousand t	Data on the Extracted Oil Since 30 March 2020 till the Valuation Date, thousand t	Extracted Oil Resources as of the Valuation Date, Reduced to Category C1, thousand t	Corrected Value of Resources, rub./t	Market Value of Resources as of the Valuation Date, thousand rub.
Deposits (investments of Neft Y)	54,717	986	0	55,210.0	85.957	4,745,665
Total:	54,717	986	0	55,210.0		4,745,665

Source: data of the customer, authors' own calculations.

An algorithm for determining the value of intangible assets according to the IVS is presented above. It was considered on the example of Neft Y and represents a sequence of actions to be taken to determine the value of the license for production of raw hydrocarbons. This structure is part of the algorithm for determining economic security of a business, because intangible assets are one of the major components that provide economic security of economic entities.

7. Discussion and Conclusions

This study analyzed the impact that the value of intangible assets and intellectual property has on capitalization of companies and their level of economic security, based on calculated values. The study relies on pair correlation relationships between the factor and performance characteristics. The impact of revenue, intangible assets, intellectual property, fixed assets, assets under construction, financial investments, current assets and long-term and short-term liabilities was analyzed.

The calculated results of the study are presented for the example of the oil and gas sector. The effect of intangible assets and intellectual property on the company value and economic security were determined.

An algorithm was developed to determine economic security based on valuation of intangible assets according to the IVS. It includes the entire cycle of the enterprise's use of intangible assets and intellectual property to calculate economic security. The algorithm includes analysis of the business entity's activities, which consists of two stages (preliminary analysis and in-depth analysis of indicators). Five interrelated blocks are presented: 1—analysis of the intangible assets and intellectual property existing in the enterprise; 2—calculation of the investments necessary for intangible assets and intellectual property; 3—analysis of the sources of the effect (possible earnings from the intangible assets and intellectual property are identified as well as the ways they can be used to attract investments in the company and increase the value of the company's assets); 4—possible expenses of the business

entity, as well as the possible options for reducing them. This section presents possible benefits in terms of profit tax due to depreciation deductions on the company's intangible assets. Thus, in the presented algorithm, qualitative assessment of the value of intangible assets and intellectual property according to the IVS is the major component revealing the economic security of business entities.

The multiple stages of the suggested algorithm make it versatile and suitable for application by companies that use intangible assets and intellectual property to different extents.

The uniqueness of the presented algorithm is due to the fact that it contains a full set of stages to manage intangible assets and intellectual property within which the values of the assets are defined in accordance with the International Valuation Standards. This is an essential component of the algorithm that determines the economic security of businesses.

The algorithm can be used to evaluate the company's activities in a new way, to prevent risks and use new possibilities related to the application and valuation of intangible assets and intellectual property according to the IVS.

The practical significance of the research is that the results of the study may be used in the operations of modern companies that apply intangible assets and intellectual property in their activities to determine sustainable development and form an effective system for economic security management due to the use of intangible assets.

Further research will involve goodwill accounting and valuation according to the IVS aimed at determining the economic security of companies.

Author Contributions: Conceptualization, D.R., O.P.; methodology, D.R., O.P.; software O.P.; validation, O.N., formal analysis, D.R., O.P. and O.N.; investigation, D.R., O.P. and O.N.; data curation and writing—original draft preparation, D.R., O.P. and O.N.; visualization, D.R., O.P.; supervision, D.R., O.P. and O.N.; project administration, Dmitrii Rodionov, O.P.; funding acquisition D.R., O.P. All authors have read and agreed to the published version of the manuscript.

Funding: This research was supported by the Academic Excellence Project 5-100 proposed by Peter the Great St. Petersburg Polytechnic University.

Acknowledgments: The authors thank everyone who helped to make the research happen.

Conflicts of Interest: The authors declare no conflict of interest. The funders had no role in the design of the study; in the collection, analyses, or interpretation of data; in the writing of the manuscript, or in the decision to publish the results.

Appendix A

Table A1. Research results for the oil and gas industry (annual data, yearly data).

Name	Average Data Values for the Period 2012–2019 (Annual Data)			
	X1	X2	X3	X4
	Revenue, Thousand Rubles	Intangible Assets and Intellectual Property Assets (Results of Research and Development, Unfinished R&D), Thousand Rubles	Fixed Assets, Thousand Rubles	Unfinished Construction Objects, Thousand Rubles
PJSC "NK" LUKOIL "	289,492,597	949,960	13,404,602	1,828,806
PJSC "GAZPROM"	4,262,855,065	15,753,276.38	7,054,326,754	704,993,665.6
PJSC TATNEFT	527,673,919.3	1,573,121	182,396,433.4	69,466,968.75
PJSC ANK "Bashneft"	576,570,420.9	2,046,907.625	133,885,790	14,934,543.88
OJSC "Surgutneftegas"	1,081,006,001	663,165.625	760,351,258.4	701,595,646.4
PJSC "Varyeganneftegaz"	30,764,814.13	416,054.25	28,743,199.25	1,814,514.375
PJSC "Gazprom Neft"	1,386,778,553	2,602,433.25	4,521,554.875	1,424,129.875
PJSC "Saratov Oil Refinery"	13,138,640.13	48,927.125	14,435,942	2,895,163.625
JSC "Slavneft-YANOS"	26,025,383.38	113,698.5	38,464,365.5	4,252,928.75
JSC "YATEK"	4,832,172.25	547,987.125	7,218,803.375	3,093,899.375
PJSC "Transneft"	800,467,224.3	5,555,425.875	58,474,417.5	0
OJSC "Slavneft-Megionneftegaz"	148,234,764.8	564,772.75	79,140,407.13	8,773,602.125

Table A2. Research results for the oil and gas industry (annual data, yearly data).

Name	Average Data Values for the Period 2012–2019 (Annual Data)			
	X5	X6	X7	Y
	Financial Investments, Thousand Rubles	Current Assets, Thousand Rubles	Long-Term Liabilities, Thousand Rubles Short-Term Liabilities, Thousand Rubles	Short-Term Liabilities, Thousand Rubles
PJSC "NK" LUKOIL "	1,216,580,860	602,968,488	751,789,453	2,716,558,602
PJSC "GAZPROM"	2,650,084,376	2,230,145,862	3,674,378,484	3,680,639,431
PJSC TATNEFT	134,775,785.9	301,011,229.3	137,405,115.8	963,896,305
PJSC ANK "Bashneft"	284,629,828.3	199,385,990.5	253,651,130.5	372,745,599
OJSC "Surgutneftegas"	1,550,931,337	959,366,193.5	196,086,680.3	1,185,722,089
PJSC "Varyeganneftegaz"	370,500	5,661,556.375	12,541,222.88	12,968,679
PJSC "Gazprom Neft"	761,421,464	577,021,391	1,017,116,814	1,106,601,590
PJSC "Saratov Oil Refinery"	7016	10,919,966.63	6,889,963.875	9,359,777
JSC "Slavneft-YANOS"	4,042,305	17,082,490.13	27,459,440.63	26,003,573
JSC "YATEK"	1,873,254.5	3,708,462.5	7,323,651.375	12,648,765
PJSC "Transneft"	739,792,902.5	243,060,328.5	889,485,084.9	1,073,188,572
OJSC "Slavneft-Megionneftegaz"	14,063,027.25	82,743,736.13	68,577,707	65,391,992

Source of information: Financial statements of companies. Trading results.

Table A3. Research results for the oil and gas industry (annual data, yearly data).

Name	Indicator Value, Thousand Rubles			Change in Indicator	
	2017	2018	2019	Thousand Rubles (r.p.4-r.p.2)	±% ((4-2): 2)
Revenue	21,495,399	33,028,289	41,785,958	+20,290,559	+94.4
Expenses for ordinary activities	19,578,326	30,879,611	38,666,550	+19,088,224	+97.5
Share of expenses in revenue	91.08%	93.49%	92.53%	92.37%	
Profit (loss) from sales (1-2)	1,917,073	2,148,678	3,119,408	+1,202,335	+62.7
Other income and expenses, except for interest payable	31,616	-545,957	-161,398	-193,014	↓
Earnings before interest and tax (EBIT) (3 + 4)	1,948,689	1,602,721	2,958,010	+1,009,321	+51.8
Percentage to be paid	-	-	-	-	-
Change in tax assets and liabilities, income tax, etc.	-388,987	-419,949	-591,602	-244,410	↓
Net profit (loss) (5-6 + 7)	1,559,702	1,182,772	2,366,408	+764,911	

Table A4. Analysis of indicators of the company (annual data, yearly data).

Name	Indicator Value					
	in Thousand Rubles				in% to the Balance Currency	
	31 December 2016	31 December 2017	31 December 2018	31 December 2019	At the Beginning of the Analyzed Period (31 December 2016)	Final Analyzed Period (31 December 2019)
Fixed assets	3,148,338	3,010,241	3,481,836	5,913,312	27.4	30.2
Intangible assets	3200	2900	2700	2500	-	-
Inventory	1,711,525	2,375,860	3,658,070	3,040,297	14.9	15.5
Receivables	2,672,876	7,415,999	7,238,580	7,561,534	23.3	38.6
Cash and short-term financial investments	477	1,597,704	360	1,177,512	<0.1	6
Long-term liabilities, total including	296,364	323,625	502,022	852,148	2.6	4.3
Borrowed funds	-	-	-	-	-	-
Short-term liabilities *, total	4,559,180	8,603,374	10,704,511	6,678,911	39.7	34.1

* Short-term, or current liabilities, are liabilities that are due within one year or less. They can include payroll expenses, rent, and accounts payable, money owed by a company to its customers.

References

- Andonova, Veneta, and Ruíz-Pava Guillermo. 2016. The role of industry factors and intangible assets in company performance in Colombia. *Journal of Business Research* 69: 4377–84. [CrossRef]
- Barth, Mary E., Ron Kasznik, and Maureen F. McNichols. 2001. Analyst Coverage and Intangible Assets. *Journal of Accounting Research* 39: 1–34. [CrossRef]
- Basso, Leonardo Fernando Cruz, Juliana Albuquerque, Saliba de Oliveira, Herbert Kimura, and Erica Sumoyama Braune. 2015. The impact of intangibles on value creation: Comparative analysis of the Gu and Lev methodology for the United States software and hardware sector. *Investigaciones Europeas de Direccion y Economia de La Empresa* 21: 73–83. [CrossRef]
- Boj, Jorge Juan, Raul Rodriguez-Rodriguez, and Juan-Jose Alfaro-Saiz. 2014. An ANP-multi-criteria-based methodology to link intangible assets and organizational performance in a Balanced Scorecard context. *Decision Support Systems* 68: 98–110. [CrossRef]
- Bontis, Nick. 2001. Assessing knowledge assets: A review of the models used to measure intellectual capital. *International Journal of Management Reviews* 3: 41–60. [CrossRef]
- Bouteiller, Christophe, and Catherine Karyotis. 2010. The evaluation of intangibles: Introducing the optional capital. *Investment Management and Financial Innovations* 7: 85–92.
- Brand Finance. 2019. Global Intangible Finance Tracker. November, p. 34. Available online: https://brandfinance.com/images/upload/gift_2.pdf (accessed on 13 November 2019).
- Chernogorsky, Sergey. 2018. A Model of Economic Growth, Including Taxation and Public Sector. Available online: <https://elibrary.ru/item.asp?id=38654012> (accessed on 25 April 2018).
- Clausen, Saskia, and Stefan Hirth. 2016. Measuring the value of intangibles. *Journal of Corporate Finance* 40: 110–27. [CrossRef]
- Courts. 2019. *Annual Report, U.S. District Courts—Copyright, Patent, and Trademark Cases Filed During the 12-Month Periods Ending June 30, 1990, and September 30, 1995 Through 2019*. Washington: Federal Courts & the Public.
- Del Giudice, Vincenzo, and Piefrancesco De Paola. 2017. The value of intellectual capital in shipping companies. *Green Energy and Technology*, 231–39. [CrossRef]
- Gu, Feng, and John Q. Li. 2015. Innovation in information systems and valuation of intangibles. In *Intangibles, Market Failure and Innovation Performance*. Basel: Springer International Publishing, pp. 291–306. [CrossRef]
- International Valuation Standards. 2020. International Valuation Standards. Available online: www.ivsc.org (accessed on 19 January 2020).
- IVSC. 2020. Nicholas Talbot, The International Valuation Standards Council, Article Covid-19 and the Valuation Profession. UK, March 2020. Available online: <https://www.ivsc.org/news/article/statement-in-relation-to-the-covid-19-pandemic> (accessed on 29 March 2020).
- Kaplan, Robert S., and David P. Norton. 2004. Measuring the Strategic Readiness of Intangible Assets. *Harvard Business Review* 82: 52–63. [PubMed]
- Matos, Florinda, Matos Oliveira, and Valter Vairinhos. 2018. The relation between companies' investments in intangibles and innovation. Paper presented at the European Conference on Knowledge Management, ECKM, Italy, Padua, September 7; vol. 1, pp. 545–54.
- Montesor, Sandro, and Antonio Vezzani. 2016. Intangible investments and innovation propensity: Evidence from the Innobarometer 2013. *Industry and Innovation* 23: 331–52. [CrossRef]
- Nejati, Ramin. 2016. Management of Intangible Assets A Value Enhancing Strategy in Knowledge Economy. *Research Journal of Humanities and Social Sciences* 7: 54. [CrossRef]
- Pastor, Damian, Josef Glova, Frantisek Lipták, and Viliam Kováč. 2017. Intangibles and methods for their valuation in financial terms: Literature review. *Intangible Capital* 13: 387–410. [CrossRef]
- Plaskova, Natalia Stepanova, Natalia Alekseevna Prodanova, Alexander Sergeevich Samusenko, Elmira Arsenova Erzinkyan, Karine Alexandrovna Barmuta, and Rustem Adamovich Shichiyakh. 2019. Investment decisions formation: Innovative assets. *International Journal of Engineering and Advanced Technology* 9: 2913–16. [CrossRef]
- Radyukova, Yana Yurievna Yu, and Ivan Nikolaevich Shamaev. 2011. As a multilevel system of elements and relationships. *Journal of Cleaner Production* 2: 194–98.

- Rodionov, Dmitry Grigorievich, Konnikov Evgeny Alexandrovich, and Konnikova Olga Nikolaevna. 2018a. Approaches to Ensuring the Sustainability of Industrial Enterprises of Different Technological Levels. *The Journal of Social Sciences Research* 3: 277–82. Available online: <https://ideas.repec.org/a/arp/tjssrr/2018p277-282.html>, (accessed on 19 January 2018).
- Rodionov, Dmitry Grigorievich, Tatiana J. Kudryavtseva, and Angi E. Skhvediani. 2018b. Human Development and Income Inequality as Factors of Regional Economic Growth. *European Research Studies Journal* XXI: 323–37. Available online: <https://ideas.repec.org/a/ers/journal/vxxiy2018ispecial2p323-337.html> (accessed on 19 June 2018).
- Russell, Marion. 2016. The Valuation of Pharmaceutical Intangibles and Drugs Mark Russell the University of Queensland. *Journal of Intellectual Capital* 17: 484–506. [CrossRef]
- Superior Court of Arbitration. 2018. *Report on Work Intellectual Property Court (First Instance)*. Moscow: Intellectual Property Court Russia.
- Tsai, Chih-Fong, Yu-Hsin Lu, Yu-Chung Hung, and David C. Yen. 2016. Intangible assets evaluation: The machine learning perspective. *Neurocomputing* 175: 110–20. [CrossRef]
- Vasconcelos, Thudichum, Dorian Forte, and Leonardo Fernando Cruz Basso. 2019. The impact of intangibles of German, English and Portuguese companies: From 1999 to 2016. *Revista de Administracao Mackenzie* 20. [CrossRef]
- World Intellectual Property Organization. 2017. *Intangible Capital in Global Value Chains*. Report. Geneva: World Intellectual Property Organization.

Publisher's Note: MDPI stays neutral with regard to jurisdictional claims in published maps and institutional affiliations.



© 2020 by the authors. Licensee MDPI, Basel, Switzerland. This article is an open access article distributed under the terms and conditions of the Creative Commons Attribution (CC BY) license (<http://creativecommons.org/licenses/by/4.0/>).

Article

Use of Neural Networks to Accommodate Seasonal Fluctuations When Equalizing Time Series for the CZK/RMB Exchange Rate

Zuzana Rowland ^{1,*}, George Lazaroiu ² and Ivana Podhorská ³

¹ School of Expertness and Valuation, Institute of Technology and Business in České Budějovice, Okružní 517/10, 37001 České Budějovice, Czech Republic

² Department of Social-Human Sciences, Faculty of Social and Human Sciences, Spiru Haret University, 041916 Bucharest, Romania; phd_lazaroiu@yahoo.com

³ Faculty of Operation and Economics of Transport and Communications, University of Žilina, Univerzitná 8215/1, 01026 Žilina, Slovakia; ivana.podhorska@fpedas.uniza.sk

* Correspondence: zuzana.rowland@seznam.cz; Tel.: +420-725-869-061

Received: 18 August 2020; Accepted: 10 October 2020; Published: 22 December 2020

Abstract: The global nature of the Czech economy means that quantitative knowledge of the influence of the exchange rate provides useful information for all participants in the international economy. Systematic and academic research show that the issue of estimating the Czech crown/Chinese yuan exchange rate, with consideration for seasonal fluctuations, has yet to be dealt with in detail. The aim of this contribution is to present a methodology based on neural networks that takes into consideration seasonal fluctuations when equalizing time series by using the Czech crown and Chinese yuan as examples. The analysis was conducted using daily information on the Czech crown/Chinese yuan exchange rate over a period of more than nine years. This is the equivalent of 3303 data inputs. Statistica software, version 12 by Dell Inc. was used to process the input data and, subsequently, to generate multi-layer perceptron networks and radial basis function neural networks. Two versions of neural structures were produced for regression purposes, the second of which used seasonal fluctuations as a categorical variable—year, month, day of the month and week—when the value was measured. All the generated and retained networks had the ability to equalize the analyzed time series, although the second variant demonstrated higher efficiency. The results indicate that additional variables help the equalized time series to retain order and precision. Of further interest is the finding that multi-layer perceptron networks are more efficient than radial basis function neural networks.

Keywords: time series; prediction; exchange rate; artificial neural networks; radial basis function; multi-layer perceptron; seasonal fluctuations; global economy

1. Introduction

At the microeconomic level, securing exchange rates has a significant impact on the development of a company's cost base, profits, and financial viability, whilst on the macroeconomic level, on a country's balance of trade. Such consequences may be the result of the correct or incorrect use of exchange rates, which is an issue many managers or important politicians will find hard to avoid. In a global economy, despite the current geopolitical and health concerns, exchange rates have a significant impact, particularly on the currencies of small and medium-sized countries, both at the micro- and macroeconomic levels (Vochozka et al. 2020).

Many economists share the view that foreign trade provides the opportunity to expand a country's potential level of consumption. As a result of this growing openness, the global economy is approaching its ideal production capacity curve. Based on the above, it can be argued that foreign trade is a factor that largely affects the stability of economies and economic growth. This is no different for the Czech Republic and the People's Republic of China.

Probably the most important indicator in the international trade environment is the exchange rate, which not only reflects the imports and exports price, but also the currency value. There is no doubt that changeability of exchange rates has a serious impact on the decisions of all entities operating in the international market for goods and services. For this reason, it is essential to set it correctly (Machova and Marecek 2019).

At present, research is focused on the development of methods that are best able to predict exchange rates. Although the scientific literature provides numerous theories and approaches used to estimate exchange rate developments including the factors affecting them, it is very surprising that the issue of seasonal fluctuations in the Czech crown/Chinese yuan exchange rate have not been addressed using artificial intelligence (artificial neural networks).

A number of studies dealing with the topic exist. However, they compare the Chinese yuan with other currencies. Similarly, the Czech crown is compared with those currencies more closely associated with it. This study is therefore unique, with the importance thereof growing with the increasing volume of Chinese investment in the Czech Republic (Foreign Direct Investment 2018–2019) and the growth of the trade balance. The aim of this paper was to present a methodological foundation based on the use of neural networks that takes into consideration the seasonal fluctuations when equalizing time series by using the Czech crown and Chinese yuan as examples.

With regard to the structure of the contribution, the literature review is partially devoted to international trade as a whole, and goes on to describe the results of studies on exchange rates and the prediction thereof using artificial intelligence. The Materials and Methods section includes the calculations for the two sets of neural networks. The results of both experiments are subsequently presented. Furthermore, the discussion provides a comparison of the results of both experiments with each other and also with those of other studies. The paper is concluded with a brief summary of all the important information and puts forward suggestions for further research.

2. Literature Review

As previously mentioned, according to Vrbka et al. (2019), international trade is considered to be crucial for economic growth, the essence of which consists of the exchange of goods, services, and capital across national borders. Horak and Machova (2019) stated that, in contrast to trade at the domestic level, the implementation of this trade type is a very complex process. On the other hand, Bernard (2004) added that for most countries, international trade plays a key role and represents a significant share of gross domestic product. The author further stated that the existence of foreign trade goes back a very long way, but that its social, political, and economic importance has only grown in recent centuries. Nevertheless, this statement does not change the fact that international trade has always been given due attention and has always been considered as very important. Li et al. (2019) considered international trade as an essential contributor to regional economic development. The authors claimed that those regions experiencing rapid growth in international trade were also those regions developing the most rapidly, as far as the economy is concerned. The issue of exchange rates is also very often discussed in connection with international trade.

Vochozka et al. (2019) stated that the conventional approach to the worldwide economy was based on the fact that exchange rates are seen as the main factor influencing external trade. Since the Czech economy is very closely linked to external trade, a quantitative understanding of the impact of exchange

rates on exports and/or imports represents an essential piece of information for all participants in the field. [Hnat and Tlapa \(2014\)](#) stated that the reasons for the decision by states to open themselves up for international trade differ, depending on the conditions and natural resources of the given country as well as on the differences in consumer habits and tastes.

[Cheong et al. \(2006\)](#) examined, for example, the dynamic relationships between exchange rate uncertainty, international trade, and price competitiveness using the United Kingdom as their example. Results based on the empirical analysis by means of vector autoregressive models (VAR) showed that shocks that stimulate exchange rate volatility have a negative influence on trade volumes and that this negative impact is stronger than the influence on trade price levels.

[Budikova et al. \(2010\)](#) stated that, like most other economic information, exchange rates have certain time dynamics (i.e., they are recorded in the form of time series). There are several possible ways to define time series. [Sheikhan et al. \(2013\)](#) provided a definition of the concept of time series and described them as a sequence of spatially and factually comparable observations that are organized in time. [De Baets and Harvey \(2018\)](#) had a simpler definition; they understood time series as sequences of values of variables arranged in an orderly manner, evenly spaced over time. [León-Alvarez et al. \(2016\)](#) defined time series analysis as a method employing the study of individuals or groups observed at successive moments. These moments represent a particular series of data points presented in chronological order. The author further added that the analysis of time series can also provide us with significant statistics and other essential data characteristics. It can be stated that, without a doubt, forecasting is one of the most important tasks of time series analysis. The reason for this is that with the help of time series prediction, based on previously monitored values, it is possible to predict values for the future. [Mai et al. \(2018\)](#) stated that the analysis and measurement of time series can also be employed primarily for predictions in the future. The author goes on to describe time series as the monitoring of certain data arranged on a time horizon from the past to the present. According to [Vochozka and Vrbka \(2019\)](#), time series provides crucial insights into the entire exchange rate development process. Prediction is considered the most important function of time analysis. The analysis of time series is a field in which neural networks are widely used. [Horak \(2019\)](#) saw their advantage in the fact that in terms of prediction, neural networks worked with big data, therefore guaranteeing a relatively high level of accuracy; neural networks, together with time series, can be used for solving complex problems and predictions. It is, of course, possible to use standard structural exchange rate models or autoregressive conditionally heteroscedasticity (ARCH) and generalized autoregressive conditionally heteroscedasticity (GARCH) models and mutations thereof. These models focus on the assumption of heteroscedasticity. In essence, they form a systematic framework for volatility modeling. Theoretically, they can be employed very successfully to measure the development of and predict the price of exchange rates that meet the above-stated assumptions, as evidenced by [Petrica and Stancu \(2017\)](#), [Quaicoe et al. \(2015\)](#), [You and Liu \(2020\)](#), and [Smallwood \(2019\)](#). However, neural networks are a very suitable alternative that produce very interesting results, and of which the potential has not yet been fully exploited. An artificial neural network is a topological arrangement of individual neurons in a structure with the help of oriented evaluated connections. Each network is therefore characterized by the type of neuron, their topological arrangement, and the strategy of adaptation during network training ([Alonso-Monsalve et al. 2020](#)). The great advantage of neural networks is their profitability, whereby the main advantage lies in the ability to learn and capture hidden, even strongly non-linear dependencies. Based on the learned experience, they then estimate a new result ([Henriquez and Kristjanpoller 2019](#)). They are able to work with inaccurate data and noise. The principle of neural networks has now been implemented in various fields of human activity and in some analytical and decision-making software products, producing very good results ([Parot et al. 2019](#)).

For example, [Laily et al. \(2018\)](#) compared ARCH and GARCH models with the Elman recurrent neural network (ERNN) when analyzing stock prices. They found that the most suitable model in this

case was GARCH, which had the smallest mean squared error (MSE). [Ortiz Arango \(2017\)](#), in turn, used GARCH models and neural network differentials (RND) to predict the future prices of financial assets, specifically the future development of the price of a barrel of oil. He found that neural networks produce better results than the basic GARCH model and are therefore a reliable alternative method for time series analysis. [Lu et al. \(2016\)](#), who predicted the volatility of log-returns in the Chinese energy market using the GARCH model and neural networks, also confirm the better predictive ability of neural networks. Similarly, [Arneric et al. \(2014\)](#), who examined the development of the Croatia stock market (CROBEX) or [Mohamed \(2013\)](#) index price by comparing GARCH models and neural networks for modeling financial returns in the market in the Arab Republic of Egypt, confirmed the better predictive power of neural networks in relation to GARCH models. Due to the findings from these studies, neural networks will be applied in this contribution for exchange rate prediction.

The application of NN (neural networks) for predicting and trading the EUR/USD exchange rate is described by [Dunis et al. \(2011\)](#). [Dhamija and Bhalla \(2011\)](#) found that NNs can be effectively used for forecasting exchange rates and therefore also for business strategy proposals. [Guresen et al. \(2011\)](#) also argued that exchange rate forecasting is an important financial issue, one that is receiving an ever-increasing amount of attention. Over the last few years, a number of neural network models and hybrid models have been put forward to exceed traditional prediction results in an effort to surpass traditional linear and non-linear approaches. [Guresen et al. \(2011\)](#) assessed the effectiveness of neural network models, which are known to be dynamic and effective in financial market forecasting. The analyzed models were multi-layer perceptrons (MLP), dynamic artificial neural networks (DAN2), and hybrid neural networks that use generalized autoregressive conditional heteroscedasticity (GARCH) to extract new input variables.

[Sindelarova \(2012\)](#) also dealt with the application of artificial neural networks (ANN) for the prediction of economic time series. First, she focused on the revision of the basic existing ANN architectures for predicting time series and described their application in predicting the CZK/EUR exchange rate. She also presented a hybrid version of ANN, as did [Bielecki et al. \(2008\)](#), which was based on the same network strategy, but tried to increase the prediction accuracy. The results of the studies are comparisons of the hybrid approach and the accuracy of traditional ANN settings for the CZK/EUR or USD/PLN exchange rates. However, due to the many parameters to be empirically assessed, it is not easy to choose a suitable NN architecture for the prediction of the exchange rate. Researchers frequently do not consider the influence of the neural network parameters on its performance. [Zhang and Hu \(1998\)](#) examined the effect of the number of the input and hidden nodes and the size of the training sample on the performance in and outside the sample. For a detailed examination, the GBP/USD exchange rate (prediction) was used. It was discovered that NNs outclass linear models, especially in the case of a short prediction horizon. [Yin and Chen \(2016\)](#) suggested a method for the application of the exponential generalized autoregressive conditional heteroscedasticity-M (EGARCH-M) model in connection with the Elman NN for predicting the return rate of the USD/CNY exchange rate. The EGARCH-M model captured the volatility asymmetry, plus the correlation between the return, and this one was past volatility; Elman's NN was used so that it corresponded with the non-linear character of the return rate. GBP/CNY and USD/CNY exchange rate predictions were carried out by [Liu et al. \(2011\)](#) using predictions by RBF neural networks and GARCH models. CNY rates can be considered as a financial TS (time series) characterized by a high non-linearity and a change of behavior over time ([Cai et al. 2012](#)). CNY has grown from a trading currency to an investment currency and currently has the potential to be a worldwide reserve currency. The development of CNY as an international currency might balance the USD dominated system and add to regional and international financial stability ([Ma and Mccauley 2011](#); [Zhang and Sato 2012](#)).

Interestingly, the correlation between the exchange rate and stock market performance was approached by [Tian and Ma \(2010\)](#), who used the autoregressive distributed lag model—ARDL's cointegration approach to examine the impact of financial liberalization on the relationship between

the exchange rate and stock market performance in China. They found that there was a cointegration between the Shanghai stock index and the renminbi (RMB) against the US dollar and the Hong Kong dollar from 2005, the year in which the Chinese exchange regime became a flexible, managed floating system. The authors found that the exchange rate and the money supply affected the share price with a positive correlation. They also showed that the increase in the money supply had been largely due to the huge influx of “hot money” from other countries in recent years.

The prediction of exchange rate changes, their link to other macroeconomic phenomena and possible geopolitical impacts have been the subject of an extremely extensive volume of research. For example, [Ilzetzi et al. \(2019\)](#) dealt with exchange rate arrangements and restrictive measures in 194 countries. [Ho and Karim \(2012\)](#) examined the significant relationship between exchange rates, macroeconomic fundamentals, and international trade in a group of Asian countries from 1980 to 2009. According to them, international trade is essential for developing countries for investment purposes and to attract foreign exchange in this liberalized and globalized world. Regression analyses show that market size and the exchange rate play a very important role in promoting international trade. Population growth has significant negative effects on developed countries like Japan and Singapore, but has positive effects on the Philippines. In addition, inflation rates have a negative impact on the Philippines and India, while financial market developments are only marginally significant in overall trade between Singapore and India. The results of the study represent the strategic policy implications for developing and developed Asian countries with regard to the facilitation of international trade and boosting growth.

In this specific field, the first area of research was concerned with the correlation of exchange rates and inflation or business cycles ([De Boer et al. 2020](#)). [Forbes et al. \(2018\)](#) used vector autoregressive modelling to reveal the links between the exchange rate and inflation, and [Nguyen and Sato \(2020\)](#) used the same method to detect asymmetries in the Japanese yen. Using an autoregressive approach, [Grabowski and Welfe \(2020\)](#) identified four main determinants of the currency market: inflation, terms of trade, country-specific risks, and the state of the currency market. The correlation of exchange rates and consumer prices with a vector autoregressive model was then examined by [Ha et al. \(2020\)](#). The VAR and the ARDL (autoregressive distributed lag) models were used by [Chiappini and Lahet \(2020\)](#) to find the key factors for 24 emerging economies, thereby demonstrating China’s fundamental influence on the exchange rates of other Asian countries. The same method was used by [Dogru et al. \(2019\)](#) to analyze the effect of exchange rates on bilateral trade between the United States, Mexico, Canada, and the United Kingdom. [Ponomareva et al. \(2019\)](#) used time series regression for predicting the exchange rates of the US dollar, Japanese yen, British pound, and euro as well as the Australian and Canadian dollars. When using the Baltic Dry Index to predict the exchange rates, [Han et al. \(2020\)](#) employed the method of time series. The use of other analytical methods is rather an exception. Behavioral equilibrium models used by [Kharrat et al. \(2020\)](#) are also relatively common as part of optimizing monetary investment strategies.

It is mainly these investment strategies and optimal security that represent the second important area of research. [Maggiore et al. \(2020\)](#) focused on global portfolios and pointed out the difference between companies in the United States and other countries where securities were usually subscribed in foreign currency. [Opie and Riddiough \(2020\)](#) presented a new method for dynamically hedging currency exposure in international equity and bond portfolios using time series. The time series prediction test was also the basis of the spot exchange rate model for 16 currencies according to [Narayan et al. \(2020\)](#) [Narayan et al.](#)

[Bahmani-Oskooee and Hegerty \(2007\)](#) provided an insight into history and stated that the increase in exchange rate volatility since 1973 has had indeterminate effects on international export and import flows. Although it can be assumed that an increase in risk may lead to a decrease in economic activity, the theoretical literature provides justification for positive or insignificant effects. Similar results were found in empirical tests. While modeling techniques have evolved over time to incorporate new developments into econometric analysis, no single degree of exchange rate volatility has dominated in the literature.

New patterns in intraday currency trading were revealed by [Khademalomoom and Narayan \(2020\)](#); and a currency trading strategy that took into account the predictive power of currency implied volatility was presented by [Ornelas and Mauad \(2019\)](#) and [Accominotti et al. \(2019\)](#).

[Bulut \(2018\)](#) successfully used Google Trends to predict exchange rates. [Amo Baffour et al. \(2019\)](#) dealt with the integration of an asymmetric model into an artificial neural network for the prediction of the exchange rates of five currencies. According to them, this hybrid solution dramatically increased the quality of the model.

The significant risk of generalization in the search for suitable predictive models was pointed out by [Cheung et al. \(2019\)](#). According to their research, the performance of models varied fundamentally, depending on the length of the prediction.

The effect of influencing the exchange rate in relation to the return on equity within the optimization models was revealed by [Turkington and Yazdani \(2020\)](#). An important topic is also investment in so-called safe-haven currencies, where, for example, [Cho et al. \(2020\)](#) are reducing the importance of the euro, which, according to them, is still one of the currencies that moves in opposition to global stock markets. The treasury-EuroDollar (TED) spread, and country-specific volatility and low liquidity factors were revealed by [Maurer et al. \(2019\)](#) as the two key sources of risk in foreign exchange (FX) markets.

Another area is represented by the use of exchange rates as an indicator of the state of an economy. [Augustin et al. \(2020\)](#) used currency swap spreads for this purpose, and [Dahlquist and Hasseltoft \(2020\)](#) stated the need to include inflation and economic stability in monetary trading strategies. Another important topic is the interconnectedness of exchange rates and commodity prices ([Liu et al. 2020](#)). The link between the type of commodities and the exchange rate, or their collapse, was revealed by [Bodart and Carpentier \(2020\)](#), according to whom the impact on agricultural exports was significantly greater compared to the relatively small impact on energy and/or mineral exports. The impact of oil price shocks, especially in the long run, on exchange rates was identified by [Huang et al. \(2020\)](#). [Chernov et al. \(2018\)](#) dealt with the quantification of the risk of currency shocks through an empirical model of bilateral exchange rates. [Colacito et al. \(2018\)](#) also focused on the 10 most traded currencies in the world. They stated their heterogeneity of exposure to trade and currency shocks. A separate chapter of the research concerns the assessment of the effectiveness of monetary unions ([Groll and Monacelli 2020](#)), very often with an overlap to crises such as that in Greece ([Kriwoluzky et al. 2019](#)). [Chari et al. \(2020\)](#) addressed the performance of economies and the benefits of a single currency. [Bonadio et al. \(2020\)](#) focused on the speed of the impact of an exchange rate shock in Switzerland. Furthermore, the topic of interventions in exchange rates in order to support export potential due to events in global markets is also current. However, as [Rajković et al. \(2020\)](#) showed in the example of the currencies of the Balkans and Central and Eastern Europe, currency depreciation did not have a significant effect on the trade deficit. Interestingly, [Xing \(2018\)](#) found the complete opposite to be true, with rising wages and the cumulative appreciation of the RMB undermining China's comparative advantage. This was also confirmed by [Choi and Choi \(2018\)](#), who found that the devaluation of the RMB had a direct effect on reducing unemployment. [Min and Yang \(2019\)](#) looked at the problem of debt risks in a currency other than the domestic currency in South Korean companies.

With regard to the RMB, attention must also be paid to the impact of exchange rate changes on economic growth and income distribution. [Ribeiro et al. \(2020\)](#) stated that although low exchange rates lead to increased exports, they have a negative impact on the income of selected groups of the population. In a sample of 2500 pairs, [Gopinath et al. \(2020\)](#) primarily assessed the effect of exchange rates on business elasticity and determined the monetary paradigm. Research on the RMB is extensive, partly as a result of a series of analyses of the impact of the reform of the People's Bank of China, which, according to [Wen and Wang \(2020\)](#), has led to reduced exchange rate volatility. This significant change was also addressed by [Smallwood \(2019\)](#), according to whom, exchange rate uncertainty has no effect on trade with the United

States, or [Cheung et al. \(2018\)](#), who dealt with the impact of these changes on central parity. [Liu and Woo \(2018\)](#) also extensively analyzed the effects of the so-called trade war between these great powers, drawing attention to the rather vague term “equilibrium exchange rate” used by many politicians and economists.

[Ho \(2020\)](#) pointed out the strong effects of virtual currencies and their exchange rates, even in terms of inflation and economic growth for Taiwan and China.

3. Materials and Methods

The data for the analysis are accessible on the [World Bank \(2020\)](#) website. The information on the mutual exchange rates of the Czech crown (hereinafter referred to as “CZK”) and the Chinese yuan (hereinafter referred to as “RMB”) were used for the purpose of the analysis (i.e., the daily exchange rate records of these currencies). The time period began on 6 October 2009 and closed on 21 October 2018, which was the equivalent of 3303 data inputs. The unit was several CZK to one RMB.

The descriptive characteristics of the dataset are presented in [Table 1](#).

Table 1. Characteristics of the dataset.

Statistics	Date–Input Variable	RMB to CZK–Output (Aim)
Minimum (training)	40,092.00	2.485800
Maximum (training)	43,394.00	4.163000
Diameter (training)	41,734.79	3.265645
Standard deviation (training)	939.26	0.392383
Minimum (testing)	40,102.00	2.496100
Maximum (testing)	43,393.00	4.155700
Diameter (testing)	41,755.71	3.272882
Standard deviation (testing)	957.97	0.394309
Minimum (validation)	40,111.00	2.498900
Maximum (validation)	43,388.00	4.152900
Diameter (validation)	41,768.68	3.246446
Standard deviation (validation)	1,438.25	0.499822
Minimum (overall)	40,092.00	2.485800
Maximum (overall)	43,394.00	4.163000
Diameter (overall)	41,743.00	3.263852
Standard deviation (overall)	953.64	0.392668

Source: Own research.

Statistica software, version 12, by Dell Inc. was used for the data processing. Data mining, neural networks (i.e., automated neural networks (ANS)) were utilized for the computation of the neural structures. A regression was performed using neural structures. Multi-layer perceptron networks (MLP) and radial basis function (RBF) NNs were then generated. The MLP network has one or more hidden layers between the input and output layers, with the neurons arranged in layers, the connections always routed from the lower to higher layers, and with no interconnection between neurons in the same layer (see [Figure 1](#)) ([Ramchoun et al. 2017](#)).

The RBF network in its simplest form is a three-layer forward neural network. The first layer corresponds to the inputs to the network, the second layer is a hidden layer consisting of a series of non-linear activation RBF units, and the last layer corresponds to the final output of the network. Activation functions in RBF are conventionally implemented as Gaussian functions (see [Figure 2](#)).

Two sets of new neural networks were generated:

1. The self-sufficient variable was time and the dependent variable was defined as the CZK/RMB exchange rate.

- Time was an independent variable. The seasonal variable was characterized by a categorical variable represented by year, month, day of month, and day of week, in which the value was measured for each variable independently. The purpose was to work with the potential daily, monthly, and annual seasonal fluctuations in time series. The dependent variable was the CZK/RMB exchange rate.

What follows next is the analogical work with the datasets. The time series was divided into three datasets (i.e., training, testing, and validation). The first dataset included 70% of the input data. The neural structures were created on the basis of the training set. Each of the two remaining datasets included 15% of the input data, respectively. Both of these datasets served to verify the reliability of the discovered neural structure (i.e., the discovered model). The time series delay was 1. In total, 100,000 neural networks were created, of which the five with the best traits were retained. The hidden layer contained at least two neurons and at most 50 neurons. For the radial basis function, the hidden layer contained at least 21 neurons and at most 30 neurons. The following distribution functions were considered for a multiple perceptron network in the hidden and output layers: Atanh, exponential, linear, logistic, and sinus. The performance of the individual datasets was defined in the form of a correlation coefficient. There were, of course, other performance measures such as root mean square error (RMSE), the mean absolute percentage error (MAPE), mean absolute bias error (MABE), and coefficient of determination (R2). The root mean square error (RMSE) is the square root of the mean square error (MSE). RMSE measures the differences between the values predicted by the hypothetical model and the observed values. In other words, it measures the quality of the fit between the actual data and the predicted model. Similarly, MAPE is a simple average of absolute percentage errors, a formula used to calculate an error in a statistical forecast that measures the magnitude of a predicted error. The coefficient of determination, R2, is a useful measure of the total value of the predictor variable(s) when predicting the resulting variable in a linear regression setting (Salkind 2010).

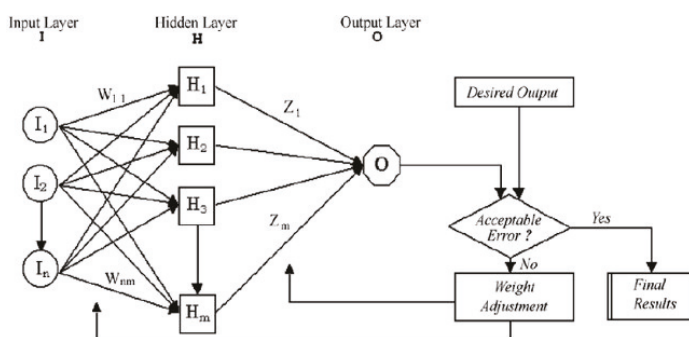

Figure 1. MLP network structure (Source: Khalafi and Mirvakili 2011).

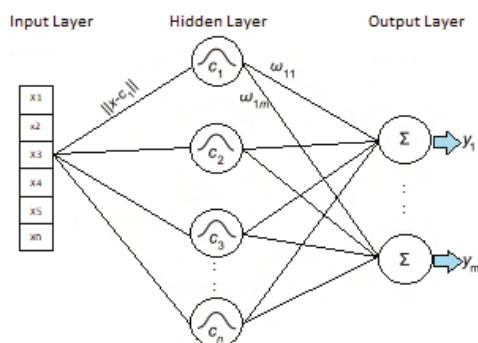

Figure 2. RBF network structure (Source: Faris et al. 2017).

The other settings remained in the default (as for ANS—automated neural networks). Finally, the results of both retained sets of neural networks were compared.

4. Results

4.1. Neural Structure A

A total of 100,000 NNs were generated in the course of the above-defined procedure. The five that displayed the best parameters were retained and are presented in Table 2.

Table 2. Retained neural networks.

Network	Training Perform.	Testing Perform.	Validation Perform.	Training Error	Testing Error	Validation Error	Training Algorithm	Error Function	Activ. of Hidden Layer	Output Activ. Function
1 RBF 1-30-1	0.983490	0.983020	0.984843	0.002516	0.002616	0.002319	RBFT	Sum.quar.	Gauss	Identity
2 RBF 1-26-1	0.984841	0.985412	0.984883	0.002312	0.002255	0.002309	RBFT	Sum.quar.	Gauss	Identity
3 RBF 1-25-1	0.986071	0.986443	0.985769	0.002126	0.002109	0.002179	RBFT	Sum.quar.	Gauss	Identity
4 RBF 1-26-1	0.985491	0.985337	0.984503	0.002213	0.002262	0.002367	RBFT	Sum.quar.	Gauss	Identity
5 RBF 1-30-1	0.984297	0.983784	0.984732	0.002394	0.002499	0.002339	RBFT	Sum.quar.	Gauss	Identity

Source: Own research; according to Machova and Marecek (2019).

All were radial basis function NNs with only one variable in the input layer (i.e., time). The NNs contained from 25 to 30 neurons in the hidden layer. There was a solo neuron and a solo output variable (i.e., the CZK/RMB exchange rate) in the output layer. The RBFT (redundant byzantine fault tolerance) training algorithm was applied to all the networks. The hidden layer of neurons of all the neural networks was activated by the same function (i.e., the Gaussian curve). Likewise, the external layers of neurons used the same function for the purpose of activation (see Table 2). The search was for a network that performed equally well across all the datasets (note: the data distribution across the datasets took place randomly), while the error should be the smallest possible. The performance of the individual datasets was represented by a correlation coefficient. The values for the individual datasets for the retained NNs are presented in Table 2.

The figures revealed that the performance of all the retained neural networks reached approximately the same results. The unimportant differences had no impact on the performance of the respective networks. The values of the correlation coefficients for all the training datasets was below 0.983. The values of the correlation coefficients for the testing datasets were very similar to the training datasets (i.e., always above 0.983) and was above 0.984 for the validation datasets. Note that the error for all the datasets was slightly above 0.002. The error differences for the equalized time series were almost insignificant for the datasets. A more detailed analysis is required to determine the most appropriate neural network. Table 3 provides an overview of the basic statistical characteristics of the individual datasets for the five retained neural networks.

Under ideal circumstances, the statistical characteristics of the neural networks should comply, in an interspace manner, in all the sets of a certain neural structure (i.e., minima, maxima, residuals, etc.). In the case of the retained neural networks, the differences between the equalized time series were minimal, both in terms of absolute values and residuals. It is therefore not clear which of the retained NNs generated the most suitable results. Therefore, all the neural networks seem to be applicable in practice.

Table 3. Statistical characteristics of the individual datasets according to the retained neural network.

Statistics	1.RBF1-30-1	2.RBF1-26-1	3.RBF1-25-1	4.RBF1-26-1	5.RBF1-30-1
Minimal prediction (training)	2.58183	2.55340	2.52919	2.52734	2.62556
Maximal prediction (training)	4.04950	4.09743	4.00225	4.00540	3.95151
Minimal prediction (testing)	2.58355	2.55342	2.52917	2.52741	2.62557
Maximal prediction (testing)	4.04944	4.09741	4.00223	4.00544	3.95152
Minimal prediction (validation)	2.58184	2.55531	2.53062	2.52749	2.62600
Maximal prediction (validation)	4.04951	4.09682	4.00226	4.00505	3.95129
Minimal residuals (training)	-0.22414	-0.21614	-0.30694	-0.24314	-0.28141
Maximal residuals (training)	0.37317	0.23107	0.22900	0.21521	0.29266
Minimal residuals (testing)	-0.21388	-0.18746	-0.28546	-0.22842	-0.26051
Maximal residuals (testing)	0.37307	0.23378	0.22341	0.20519	0.29323
Minimal residuals (validation)	-0.21094	-0.17494	-0.17479	-0.20650	-0.23232
Maximal residuals (validation)	0.26023	0.22773	0.18504	0.21784	0.21065
Minimal standard residuals (training)	-4.46833	-4.49505	-6.65757	-5.16815	-5.75120
Maximal standard residuals (training)	7.43936	4.80567	4.96689	4.57450	5.98108
Minimal standard residuals (testing)	-4.18178	-3.94719	-6.21611	-4.80292	-5.21090
Maximal standard residuals (testing)	7.29438	4.92251	4.86501	4.31438	5.86540
Minimal standard residuals (validation)	-4.38041	-3.64037	-3.74445	-4.24472	-4.80316
Maximal standard residuals (validation)	5.40392	4.73891	3.96396	4.47779	4.35511

Source: Machova and Marecek (2019).

Figure 3 is a line graph that shows the actual development of the CZK/RMB exchange rate at the individual intervals in a slightly different manner. The x-axis (case number) shows information about the input data (i.e., about the time series (marked by numbers due to the software settings)), whilst the y-axis shows the value of the CZK/RMB exchange rate. The blue line indicates the actual development of the exchange rate, and the other colors show the predictions according to the individually generated and retained networks (as presented in Table 2). The close similarity of the predictions of the individual networks is not important, but rather the extent of compliance to the actual development of the exchange rate. Within this context, it can be concluded that all the undistributed neural networks are seemingly very interesting. On the face of it, the basic directions of the lines, which assess the course of the CZK/RMB exchange rate, display the extremes in the development of the actual exchange rate.

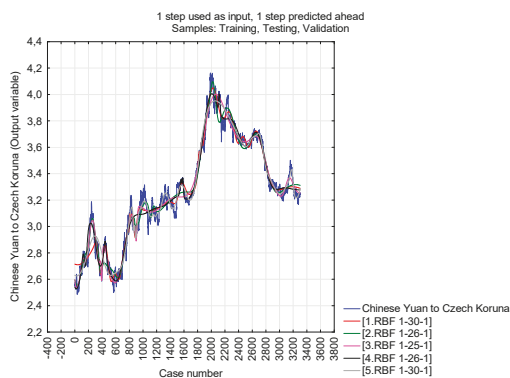

Figure 3. Actual and predicted (according to retained neural networks) development of CZK/RMB exchange rate during the monitored period (Source: Own research; according to Machova and Marecek 2019).

Given that the network structure (as depicted in Figure 1) contains 3303 items of data on the CZK/RMB exchange rate, this may seem unclear. It is therefore appropriate to present the situation for a selected data interval. Therefore, the line graph in Figure 4 compares the actual development of the CZK/RMB exchange rate for the final 100 days of the monitored period (i.e., from 14 July to 21 October 2018.)

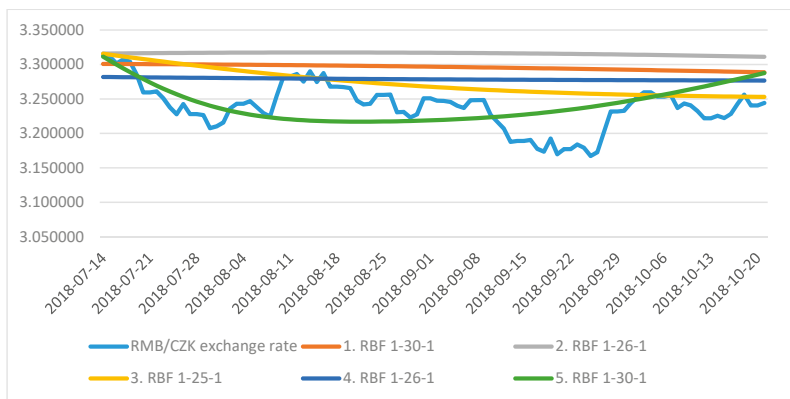

Figure 4. Actual and predicted (according to retained neural networks) development of the CZK/RMB exchange rate for the period from 14 July to 21 October 2018 (Source: Own research; according to Machova and Marecek 2019).

The graph shows that none of the retained neural networks were completely and accurately able to trace the actual course of the CZK/RMB exchange rate during the monitored period. However, it was clear that the 3.RBF 1-25-1 and 5.RBF 1-30-1 networks came the closest to reality. Their predicted values were almost identical to the actual exchange rate at the beginning of the monitored period, with more significant differences showing at the end of the monitored period. The difference in both cases was about CZK 0.08 to one RMB. Even the least accurate network, namely 2.RBF 1-26-1, differed from the actual figures for the exchange rate by less than CZK 0.011. An examination of the residuals therefore seems appropriate. The development of the residuals during the period from 14 July to 21 October 2018 is presented in Figure 5.

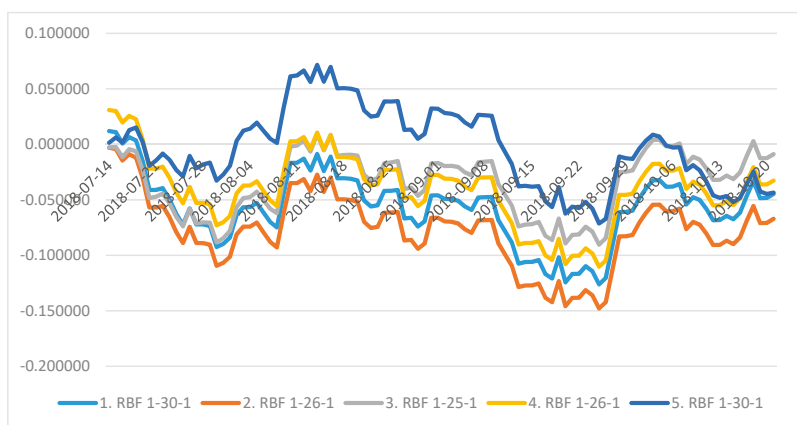

Figure 5. Development of residuals for the equalized time series during the period from 14 July to 21 October (Source: Own research; according to Machova and Marecek 2019).

The graph shows that, with exception of the 5.RBF 1-30-1 network, the aggregate of the residuals for all the neural networks during the monitored period was almost zero. The residuals achieved quite high positive values in this period. To illustrate this, Table 4 shows the aggregate of the residuals for the equalized time series.

Table 4. Aggregate of the residuals for the individual equalized time series.

Characteristics	1.RBF 1-24-1	2.RBF 1-29-1	3.RBF 1-30-1	4.RBF 1-28-1	5.RBF 1-26-1
Aggregate of residuals	0.150758	−1.025922566	−3.350398611	−1.785245346	−3.244516106

Source: Own research; according to Machova and Marecek (2019).

Under ideal circumstances, if we ignore the residual fluctuations for the individual cases during the monitored period, the absolute value of the aggregates of the residuals will total zero. The absolute value of the aggregate of the residuals of the second neural network (2.RBF 1-29-1), which was nearly −1.026, was the closest to zero. In contrast, the 3.RBF 1-30-1 and 5.RBF 1-26-1 networks produced the highest aggregate of residuals in absolute terms, with values above 3. However, it is necessary to point out that this value is minimal in relation to the 3303 measurements. It is therefore possible to state that the most accomplished neural networks were 3.RBF 1-25-1 and 5.RBF 1-30-1.

4.2. Neural Structure B

A total of 100,000 NNs were generated on the basis of the defined procedure. The five that displayed the best parameters were retained and are presented in Table 5.

Table 5. Retained neural networks.

Network	Training Perform.	Testing Perform.	Validation Perform.	Training Error	Testing Error	Validation Error	Training Algorithm	Error Function	Activ. of Hidden Layer	Output Activ. Function
1 MLP 61-11-1	0.998718	0.996990	0.997563	0.000197	0.000468	0.000374	BFGS (Quasi-Newton) 392	Sum quart.	Tanh	Identity
2 MLP 61-11-1	0.998927	0.997313	0.997517	0.000165	0.000417	0.000382	BFGS (Quasi-Newton) 461	Sum quart.	Logistic	Identity
3 MLP 61-11-1	0.998919	0.997606	0.997632	0.000166	0.000377	0.000364	BFGS (Quasi-Newton) 569	Sum quart.	Tanh	Identity
4 MLP 61-11-1	0.998791	0.997572	0.997594	0.000186	0.000377	0.000372	BFGS (Quasi-Newton) 558	Sum quart.	Tanh	Exponential
5 MLP 61-10-1	0.998640	0.997059	0.997641	0.000209	0.000457	0.000363	BFGS (Quasi-Newton) 436	Sum quart.	Tanh	Tanh

Source: Own research.

All were multi-layer perceptron neural networks. There were four variables (i.e., time, year, day of month, day of week, in the input layer). Time was represented by one neuron in the input layer, a year by 10 neurons, a month by 12 neurons, a weekday by 7 neurons, and a day of the month by 31 neurons, respectively. The total (i.e., 61 neurons) formed the input layer of the generated and retained neural networks. The neural networks contained either 10 or 11 neurons in the hidden layer. Consequently, there was a single neuron and a single output variable, which was the CZK/RMB exchange rate, in the output layer. The Quasi-Newton training algorithm was applied to all the networks. All the neural networks used either the hyperbolic tangent or logistic functions for the purpose of the activation of the neural hidden layer. For the activation of the neural output layer, the retained neural networks used the hyperbolic tangent, exponential, and identity functions (see Table 5).

The search was for a network that performed equally well across all the datasets (note: the data distribution across the datasets took place randomly), while the error should be the smallest possible.

The performance of the individual sets was represented by a correlation coefficient. The values for the individual datasets for the retained NNs are presented in Table 5.

The table shows that the performance of all the retained neural networks was approximately the same. The insignificant differences bear no influence on the performance of the individual networks. The values of the correlation coefficients for all the training datasets significantly exceeded 0.998. The values of the correlation coefficients for the testing datasets exceeded 0.997, and for the validation datasets, they significantly exceeded 0.997. Note that the error for all the datasets fell within the interval >0.0001 to <0.0005 . The error differences for the equalized time series were completely insignificant for the individual datasets.

A more detailed analysis is required to determine the most appropriate neural network. Table 6 provides an overview of the basic statistical characteristics of the individual datasets for the five retained neural networks.

Table 6. Statistical characteristics of individual datasets according to the retained neural network.

Statistics	1.MLP61-11-1	2.MLP61-11-1	3.MLP61-11-1	4.MLP61-11-1	5.MLP61-10-1
Minimal prediction (training)	5.99845	6.00641	5.99154	5.99371	6.00098
Maximal prediction (training)	9.84882	9.89527	9.87232	9.83699	9.88105
Minimal prediction (testing)	6.45895	6.46012	6.45663	6.45980	6.46002
Maximal prediction (testing)	9.95255	9.99209	9.96231	9.95287	9.99096
Minimal prediction (validation)	6.38529	6.39955	6.38028	6.38217	6.39652
Maximal prediction (validation)	9.83693	9.84308	9.83457	9.83696	9.84264
Minimal residuals (training)	-0.17159	-0.19452	-0.16813	-0.17882	-0.19039
Maximal residuals (training)	0.40824	0.50655	0.50247	0.55336	0.55220
Minimal residuals (testing)	-0.26528	-0.23472	-0.19660	-0.24778	-0.19037
Maximal residuals (testing)	0.20029	0.23874	0.22354	0.19344	0.21280
Minimal residuals (validation)	-0.18526	-0.18002	-0.17583	-0.17599	-0.17991
Maximal residuals (validation)	0.49820	0.48575	0.49862	0.49338	0.48770
Minimal standard residuals (training)	-5.65878	-5.87540	-5.56482	-5.12649	-5.87337
Maximal standard residuals (training)	14.23498	15.85302	15.20208	14.18194	15.03849
Minimal standard residuals (testing)	-5.02283	-5.74512	-6.00274	-6.12485	-5.34937
Maximal standard residuals (testing)	5.20498	4.99831	5.48930	5.40087	4.35498
Minimal standard residuals (validation)	-4.94651	-3.99879	-4.84632	-4.57713	-3.96781
Maximal standard residuals (validation)	11.59751	11.00974	11.75020	11.34307	11.01994

Source: Own research.

In the case of the retained neural structures, the differences over the equalized time series were minimal, both in terms of absolute values and residuals. It is therefore not clear which of the retained NNs generated the most suitable results. All the neural networks therefore seem to be applicable in practice.

Figure 6 is a line graph, which shows the actual development of the CZK/RMB exchange rate and the development of predictions with the help of the individually generated and retained networks (i.e., the equalized time series). The graph clearly shows that all the neural structures predicted the development of the CZK/RMB exchange rate almost identically. Furthermore, the course of the equalized time series was very similar to the actual course of the CZK/RMB exchange rate.

Taking into consideration that the graph illustrated in Figure 6 contains 3303 items of data on the CZK/RMB exchange rate, it may seem confusing. For this reason, it is suitable to present the situation for a selected data interval. The line graph in Figure 7 therefore compares the actual development of the CZK/RMB exchange rate for the final 100 days of the monitored period (i.e., from 14 July to 21 October 2018).



Figure 6. Actual and predicted (according to retained neural networks) development of the CZK/RMB exchange rate during the monitored period (Source: Own research).

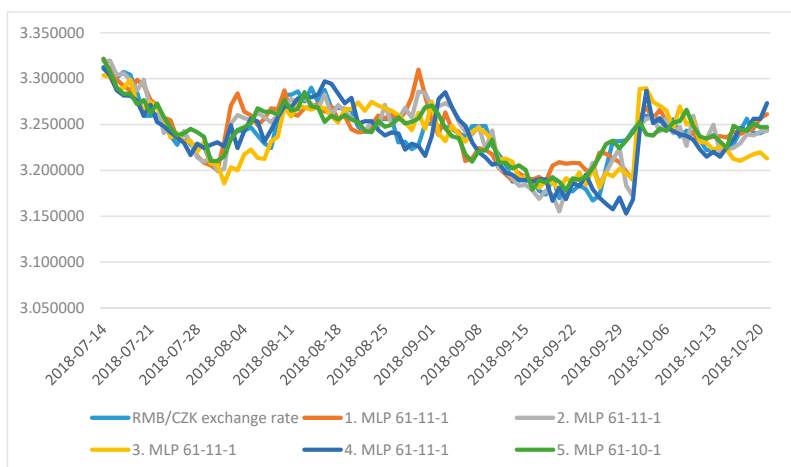

Figure 7. Actual and predicted (according to retained neural networks) development of the CZK/RMB exchange rate for the period from 14 July to 21 October 2018 (Source: Own research).

The graph clearly shows that all the neural structures were able to copy the CZK/RMB exchange rate quite well. The maximum difference across the interval was CZK 0.05. The biggest difference could be found within the period from 9/26/2018 to 10/1/2018, when the difference was still less than CZK 0.1. It is therefore possible to state on the mere basis of the graphic comparison that all the retained neural structures are usable for predictive purposes. An examination of the residuals therefore seems appropriate and interesting. The development of the residuals during the period from 14 July to 21 October is presented in Figure 8.

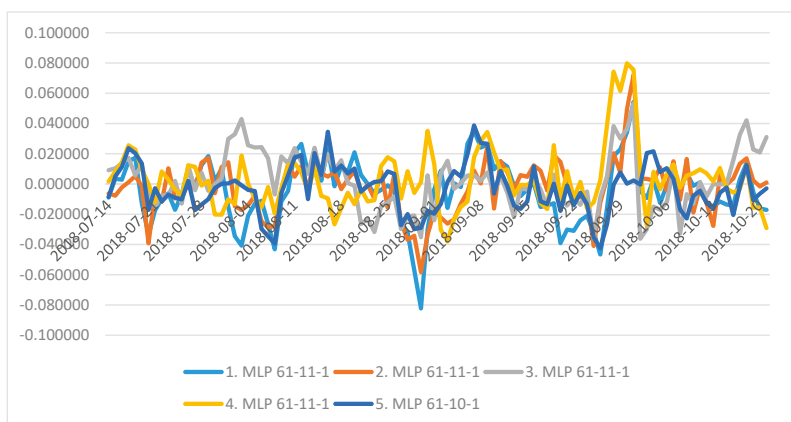

Figure 8. Development of residuals for the equalized time series during the period from 14 July to 21 October (Source: Own research).

The graph clearly shows that the aggregate of the residuals for all neural networks during the monitored period verged on zero. To illustrate this, Table 7 shows the aggregate of the residuals for the equalized time series.

Table 7. Aggregate of the residuals for the individual equalized time series.

Characteristics	1.MLP 61-11-1	2.MLP 61-11-1	3.MLP 61-11-1	4.MLP 61-11-1	5.MLP 61-10-1
Aggregate of residuals	0.632230639	0.120515671	−0.437742553	0.738084025	0.803606299

Source: Own research.

The aggregate of the residuals for the fifth neural structure, namely 2.MLP 61-11-1, was closest to the value zero (i.e., 0.12). In contrast, the neural network with the highest value for the aggregate of the residuals (0.738) was 4.MLP 61-11-1 where the differences were absolutely minimal. It is therefore possible to conclude that all the retained neural structures are able to equalize the time series for the CZK/RMB exchange rate in a very reliable manner and are usable for the prediction of the development of the exchange rate.

5. Discussion

All the generated and retained ANNs were able to balance the examined time series (i.e., the CZK/RMB exchange rate). A comparison of the correlation coefficients clearly showed (see tables 2 and 5) that alternative B (i.e., the retained MLP neural networks, which include the use of additional categorical variables) was more efficient. This is reflected in tables 3 and 6 with regard to the evaluation of the basic statistical characteristics for predictions or equalized time series. The retained MLP neural networks (i.e., their equalized time series) generated smaller mutual differences in the training, testing, and validation datasets than the retained RBF neural networks (i.e., without an additional variable). This was confirmed in Figures 3–8. It is very clear that only the retained MLP neural networks under neural structure B were able to describe the time series according to their actual course (for more details see Figure 9).

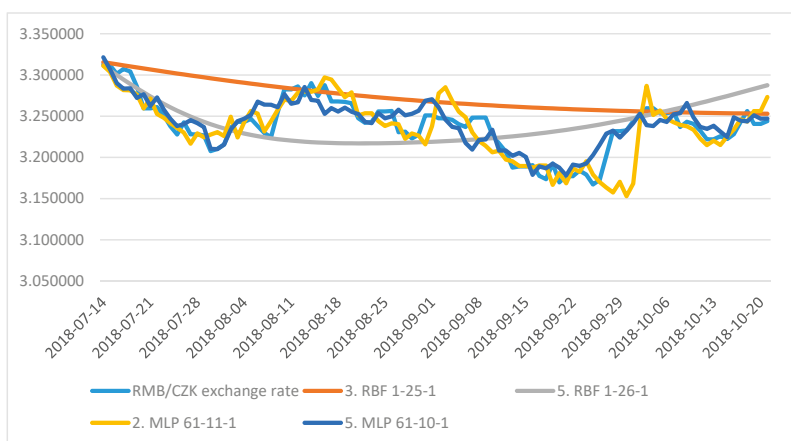

Figure 9. Comparison of selected neural networks for equalized time series for the CZK/RMB exchange rate during the period from 14 July to 21 October 2018 (Source: Own research).

A number of other authors have also dealt with the prediction of exchange rates using ANN. Although their findings are interesting, they deal with a partially different application than the one addressed in this contribution.

For example, the goal of [Ismail et al. \(2018\)](#) was to predict the exchange rate of the US dollar expressed in Malaysian ringgit. The exchange rate prediction was performed using two methods, namely artificial neural networks and the autoregressive integrated moving average (ARIMA). To predict the exchange rate, a feed-forward neural network was chosen as the artificial neural structure because this proved to be inherently stable. On the other hand, ARIMA (0,1,1) was chosen as the best model for time series based on the Box–Jenkins method. When comparing the two methods, the authors concluded that, compared to ARIMA, the feed-forward neural network showed better results because it had a smaller mean square error and a root mean square error. The research therefore shows that for predicting the US dollar exchange rate expressed in Malaysian ringgit, the use of a feed-forward neural structure seems to be a more suitable prediction method than the ARIMA time series model (0,1,1). The neural structures highlighted in this contribution also generated very good results. The neural networks faithfully copied the development of the time series and predicted the development of the exchange rate.

Through their research, [Jiang and Song \(2010\)](#) demonstrated the chaotic nature of time series for exchange rates. The authors also calculated the embedding dimension and time series delay, and determined the exchange rate prediction model using the NARX network (non-linear autoregressive model). The authors used the time series for exchange rates to empirically evaluate the proposed approach for mid-period forecasting tasks. The results showed that the proposed approach consistently outperformed standard predictors based on neural networks such as BP (back propagation) or SVM (support vector machine).

It is also worth mentioning [Abdullah \(2013\)](#), who, on the basis of the aforementioned, predicted the MYR/USD (MYR = Malaysian Ringgit) exchange rate. In his study, the author also tested the exchange rate performance using a distance-based fuzzy time series model. MYR/USD exchange rate data were tested according to a prediction model from 11 August 2009 to 15 September 2009. A performance comparison sample was performed between MYR/USD and TWD/USD (TWD = Taiwan New Dollar) datasets. The research results showed that the predictions for MYR/USD were smaller than TWD/USD.

The application of the research presented in this contribution is also interesting. It is clear that the RMB is perceived, mainly due to the strict monetary control of the People's Bank of China ([Cheong et al. 2017](#)), as a relatively controversial currency. On the other hand, in the current situation of relatively massive budget deficits and quantitative easing, where [Aizenman et al. \(2020\)](#) already point out the correlation, it is clear that for users of less important currencies (CZK, PLN, HUF, and others), it provides monetary security. Security is therefore not only to be considered through currency pairs with the USD or the EUR, respectively, but also within the framework of risk diversification and partly against the RMB. On one hand, this approach presents risks due to the potential for trade wars between China and the United States ([Liu and Woo 2018](#)), but it also presents extraordinary opportunities. As [Ding et al. \(2020\)](#), who analyzed the link between RMB and the price of oil, and [Kunze \(2019\)](#) stated, the controlled exchange rate can act as a stabilizing element, or even as a refining factor for predictions. However, high-quality analytical-predictive tools are absolutely necessary for this approach. This is exactly what has been provided by this study.

6. Conclusions

The aim of this contribution was to put forward a methodology for how to account for seasonal variations in the process of equalizing time series for the CZK/RMB exchange rate through the use of ANNs. In general, the fulfilment of every forecast is, to a certain degree, determined by the probability

this will occur on its own. When predicting the future development of any variable, there is an attempt to estimate the evolution of this variable on the basis of past data. Even though we are able to integrate the majority of factors that influence the target quantity into a model, there is always an element of simplification involved. It is for this reason that a certain degree of probability that a predicted scenario will take place is always taken into account. This can be considered as a limitation of the research, as can the use of basic types of NNs and the comparison of this method with the results of other suitable alternatives.

This contribution refers to the application of an identical instrument to various initial tasks. Prior to the experiment, the assumption was made that there was no reason to apply categorical variables in order to describe the seasonal fluctuations in the CZK/RMB exchange rate. However, the opposite turned out to be true. Extra variables—in the form of a year, a month, day of month, and day of week—the values of which were determined—brought better order and accuracy into the time series. The development of the CZK/RMB exchange rate can be defined on the basis of any statistical, causal, or easy-to-use methods. In this case, statistical methods were used. However, these only provided us with a potential framework for future development. Within this context, it is also important to consider possible future developments in economic policy and/or the legal environment. At the same time, the personality of the evaluator is of equal importance. Generally speaking, they are economists who correct the price defined by the framework methods and modify them on the basis of casual relations and/or on the basis of their experience and knowledge. Nevertheless, in this case, it seems appropriate to try to make a prediction using neural structure B, which is quite accurate.

The results of the MPL networks were very interesting. The objective of this contribution was therefore fulfilled. Interestingly, in the case of neural structure A, only radial basis function neural networks were retained as the most successful, whereas multi-layer perceptron neural networks were the most successful for neural structure B. What would have been interesting would have been to generate only one type of neural network for a specific situation (i.e., every time in a different manner from the acquired results (for alternative A, an MPL network, and for alternative B, an RBF network)).

In further research, it would also be interesting to compare the performance of neural structures with the performance of other models used for time series predictions such as ARIMA models, assuming the use of identical data. However, this would still require the use of statistical methods, which, once again, only provide a possible framework for exchange rate developments. As a result, it would be desirable to include information on the development of the economic, political, and/or legal environments in the model. Where it is possible to do so and to predict such developments, it will then be possible to project this into the monitored variable accordingly.

Author Contributions: Conceptualization, Z.R. and G.L.; Methodology, Z.R.; Software, Z.R.; Validation, G.L.; Formal analysis, I.P.; Investigation, G.L.; Resources, I.P.; Data curation, Z.R. and G.L.; Writing—original draft preparation, Z.R. and G.L.; Writing—review and editing, I.P.; Visualization, Z.R. and I.P.; Supervision, Z.R.; Project administration, Z.R. All authors have read and agreed to the published version of the manuscript.

Funding: This research received no external funding.

Conflicts of Interest: The authors declare no conflict of interest.

References

- Abdullah, Lazim. 2013. Performance of exchange rate forecast using distance-based fuzzy time series. *International Journal of Engineering and Technology* 5: 452–59.
- Accominotti, Olivier, Jason Cen, David Chambers, and Ian W. Marsh. 2019. Currency regimes and the carry trade. *Journal of Financial and Quantitative Analysis* 54: 2233–60. [\[CrossRef\]](#)
- Aizenman, Joshua, Yin-Wong Cheung, and Xiangwang Qian. 2020. The currency composition of international reserves, demand for international reserves, and global safe assets. *Journal of International Money and Finance* 102. [\[CrossRef\]](#)

- Alonso-Monsalve, Saúl, Andrés L. Suarez-Cetrulo, Alejandro Cervantes, and David Quintana. 2020. Convolution on neural networks for high-frequency trend prediction of cryptocurrency exchange rates using technical indicators. *Expert Systems with Applications* 149. [CrossRef]
- Amo Baffour, Alexander, Jingchun Feng, and Evans Kwesi Taylor. 2019. A hybrid artificial neural network-GJR modeling approach to forecasting currency exchange rate volatility. *Neurocomputing* 365: 285–301. [CrossRef]
- Arneric, Josip, Tea Poklepovic, and Zdravka Aljinovic. 2014. GARCH based artificial neural networks in forecasting conditional variance of stock returns. *Croatian Operational Research Review* 5: 329–43. [CrossRef]
- Augustin, Patrick, Mikhail Chernov, and Dongho Song. 2020. Sovereign credit risk and exchange rates: Evidence from CDS quanto spreads. *Journal of Financial Economics* 137: 129–51. [CrossRef]
- Bahmani-Oskooee, Mohsen, and Scott W. Hegerty. 2007. Exchange rate volatility and trade flows: A review article. *Journal of Economic Studies* 34: 211–55. [CrossRef]
- Bernard, Andrew B. 2004. Exporting and productivity in the USA. *Oxford Review of Economic Policy* 20: 343–57. [CrossRef]
- Bielecki, Anrzej, Pawel Hajto, and Robert Schaefer. 2008. Hybrid neural systems in exchange rate prediction. *Studies in Computational Intelligence: Natural Computing in Computational Finance* 100: 211–30. [CrossRef]
- Bodart, Vincent, and Jean-Francois Carpentier. 2020. Currency collapses and output dynamics in commodity dependent countries. *Emerging Markets Review* 42. [CrossRef]
- Bonadio, Barthélémy, Andreas Fischer, and Philip Sauré. 2020. The speed of exchange rate pass-through. *Journal of the European Economic Association* 18: 506–38. [CrossRef]
- Budikova, Marie, Maria Kralova, and Bohumil Maros. 2010. *Průvodce Základními Statistickými Metodami* [Guide to Basic Statistical Methods]. Prague: Grada.
- Bulut, Levent. 2018. Google Trends and the forecasting performance of exchange rate models. *Journal of Forecasting* 37: 303–15. [CrossRef]
- Cai, Zongwu, Linna Chen, and Ying Fang. 2012. A new forecasting model for USD/CNY exchange rate. *Studies on Nonlinear Dynamics and Econometrics* 16. [CrossRef]
- Chari, V.V., Alessandro Dovis, and Patrick J. Kehoe. 2020. Rethinking optimal currency areas. *Journal of Monetary Economics* 111: 80–94. [CrossRef]
- Cheong, Calvin W.H., Jothee Sinnakkannu, and Sockalingam Ramasamy. 2017. On the predictability of carry trade returns: The case of the Chinese Yuan. *Research in International Business and Finance* 39: 358–76. [CrossRef]
- Cheong, Chongcheul, Tesfa Mehari, and Leighton Vaughan Williams. 2006. Dynamic links between unexpected exchange rate variation, prices, and international trade. *Open Economies Review* 17: 221–33. [CrossRef]
- Chernov, Mikhail, Jeremy Graveline, and Irina Zviadadze. 2018. Crash risk in currency returns. *Journal of Financial and Quantitative Analysis* 53: 137–70. [CrossRef]
- Cheung, Yin-Wong, Cho-Hoi Hui, and Andrew Tsang. 2018. Renminbi central parity: An empirical investigation. *Pacific Economic Review* 23: 164–83. [CrossRef]
- Cheung, Yin-Wong, Menzie D. Chinn, Antonio Garcia Pascual, and Yi Zhang. 2019. Exchange rate prediction redux: New models, new data, new currencies. *Journal of International Money and Finance* 95: 332–62. [CrossRef]
- Chiappini, Raphael, and Delphine Lahet. 2020. Exchange rate movements in emerging economies—Global vs regional factors in Asia. *China Economic Review* 60. [CrossRef]
- Cho, Jae-Beom, Hong-Ghi Min, and Judith Ann McDonald. 2020. Volatility and dynamic currency hedging. *Journal of International Financial Markets, Institutions and Money* 64. [CrossRef]
- Choi, Yoonho, and E. Kwan Choi. 2018. Unemployment and optimal exchange rate in an open economy. *Economic Modelling* 69: 82–90. [CrossRef]
- Colacito, Ric, Mariano M. Croce, Federico Gavazzoni, and Robert Ready. 2018. Currency risk factors in a recursive multicountry economy. *The Journal of Finance* 73: 2719–56. [CrossRef]
- Dahlquist, Magnus, and Henrik Hasseltoft. 2020. Economic momentum and currency returns. *Journal of Financial Economics* 136: 152–67. [CrossRef]
- De Baets, Shari, and Nigel Harvey. 2018. Forecasting from time series subject to sporadic perturbations: Effectiveness of different types of forecasting support. *International Journal of Forecasting* 34: 163–80. [CrossRef]

- De Boer, Jantke, Kim J. Bövers, and Steffen Meyer. 2020. Business cycle variations in exchange rate correlations: Revisiting global currency hedging. *Finance Research Letters* 33. [\[CrossRef\]](#)
- Dhamija, Ajay K., and V. K. Bhalla. 2011. Exchange rate forecasting: comparison of various architectures of neural networks. *Neural Computing and Applications* 20: 355–63. [\[CrossRef\]](#)
- Ding, Haoyuan, Yuying Jin, Cong Qin, and Jiezhou Ying. 2020. Tail causality between crude oil price and RMB exchange rate. *China & World Economy* 28: 116–34. [\[CrossRef\]](#)
- Dogru, Tarik, Cem Isik, and Ercan Sirakaya-Turk. 2019. The balance of trade and exchange rates: Theory and contemporary evidence from tourism. *Tourism Management* 74: 12–23. [\[CrossRef\]](#)
- Dunis, Christian L., Jason Laws, and Georgios Sermpinis. 2011. Higher order and recurrent neural architectures for trading the EUR/USD exchange rate. *Quantitative Finance* 11: 615–29. [\[CrossRef\]](#)
- Faris, Hossam, Ibrahim Aljarah, and Seyedali Mirjalili. 2017. Evolving Radial Basis Function networks using Moth-Flame optimizer. *Handbook of Neural Computation*, 537–50. [\[CrossRef\]](#)
- Forbes, Kristin, Ida Hjortsoe, and Tsvetelina Nenova. 2018. The shocks matter: Improving our estimates of exchange rate pass-through. *Journal of International Economics* 114: 255–75. [\[CrossRef\]](#)
- Foreign Direct Investment. 2018–2019. Obecný metodický popis a komentář k vývoji přímých zahraničních investic [General methodological description and commentary on the development of foreign direct investment]. In *Www.cnb.cz*. Prague: Czech National Bank.
- Gopinath, Gita, Emine Boz, Camila Casas, Federico J. Díez, Pierre-Olivier Gourinchas, and Mikkel Plagborg-Møller. 2020. Dominant currency paradigm. *American Economic Review* 110: 677–719. [\[CrossRef\]](#)
- Grabowski, Wojciech, and Aleksander Welfe. 2020. The Tobit cointegrated vector autoregressive model: An application to the currency market. *Economic Modelling* 89: 88–100. [\[CrossRef\]](#)
- Groll, Dominik, and Tommaso Monacelli. 2020. The inherent benefit of monetary unions. *Journal of Monetary Economics* 111: 63–79. [\[CrossRef\]](#)
- Guresen, Erkam, Gulgun Kayakutlu, and Tugrul U. Daim. 2011. Using artificial neural network models in stock market index prediction. *Expert systems with Applications* 38: 10389–97. [\[CrossRef\]](#)
- Ha, Jongrim, M. Marc Stocker, and Hakan Yilmazkuday. 2020. Inflation and exchange rate pass-through. *Journal of International Money and Finance* 105. [\[CrossRef\]](#)
- Han, Liyan, Li Wan, and Yang Xu. 2020. Can the Baltic Dry Index predict foreign exchange rates? *Finance Research Letters* 32. [\[CrossRef\]](#)
- Henriquez, Jonatan, and Werner Kristjanpoller. 2019. A combined independent component analysis-neural network model for forecasting exchange rate variation. *Applied Soft Computing* 83. [\[CrossRef\]](#)
- Hnat, Pavel, and Martin Tlapa. 2014. China-V4 Investment regime—a Czech perspective. Paper presented at Trends and Perspectives in Development of China-V4 Trade and Investment, Bratislava, Slovakia, March 12–14; pp. 82–95.
- Ho, Chi Ming. 2020. Does virtual currency development harm financial stocks' value? Comparing Taiwan and China markets. *Economic Research-Ekonomska Istraživanja* 33: 361–78. [\[CrossRef\]](#)
- Ho, S. F., and Norzifah Abdul Karim. 2012. Exchange rate, macroeconomic fundamentals and international trade. *2012 IEEE Colloquium on Humanities, Science and Engineering Research* 534–38. [\[CrossRef\]](#)
- Horak, Jakub, and Veronika Machova. 2019. Comparison of neural networks and regression time series on forecasting development of US imports from the PRC. *Littera Scripta* 12: 22–36.
- Horak, Jakub. 2019. Using artificial intelligence to analyse businesses in agriculture industry. Paper presented at SHS Web of Conferences—Innovative Economic Symposium 2018 Innovative Economic Symposium 2018: Milestones and Trend of World Economy, Beijing, China, November 8–9; vol. 61. [\[CrossRef\]](#)
- Huang, Shupe, Haizhong An, and Brian Lucey. 2020. How do dynamic responses of exchange rates to oil price shocks co-move? From a time-varying perspective. *Energy Economics* 86. [\[CrossRef\]](#)
- Ilzetzki, Ethan, Carmen M. Reinhart, and Kenneth S. Rogoff. 2019. Exchange arrangements entering the twenty-first century: Which anchor will hold? *The Quarterly Journal of Economics* 134: 599–646. [\[CrossRef\]](#)
- Ismail, Munira, Nurul Zafrah Jubley, and Zalina Mohd Ali. 2018. Forecasting Malaysian Foreign exchange rate using artificial neural network and ARIMA time series. Paper presented at International Conference on Mathematics, Engineering and Industrial Applications, Kuala Lumpur, Malaysia, July 24–26; vol. 2013. [\[CrossRef\]](#)

- Jiang, Chuanjin, and Fugen Song. 2010. Forecasting chaotic time series of exchange rate based on nonlinear autoregressive model. Paper presented at 2nd IEEE International Conference on Advanced Computer Control, ICACC, Shenyang, China, March 27–29; vol. 5, pp. 238–41. [\[CrossRef\]](#)
- Khademaloom, Siroos, and Paresh Kumar Narayan. 2020. Intraday-of-the-week effects: What do the exchange rate data tell us? *Emerging Markets Review* 43. [\[CrossRef\]](#)
- Khalafi, Farshad Faghihi H., and Seyed Mohammad Mirvakili. 2011. A literature survey of neutronics and thermal-hydraulics codes for investigating reactor core parameters; artificial neural networks as the VVER-1000 core predictor. *Nuclear Power–System Simulations and Operation* 103–22. [\[CrossRef\]](#)
- Kharrat, Sabrine, Yacine Hammami, and Ibrahim Fatnassi. 2020. On the cross-sectional relation between exchange rates and future fundamentals. *Economic Modelling* 89: 484–501. [\[CrossRef\]](#)
- Kriwoluzky, Alexander, Gernot J. Müller, and Martin Wolf. 2019. Exit expectations and debt crises in currency unions. *Journal of International Economics* 121. [\[CrossRef\]](#)
- Kunze, F. 2019. Predicting exchange rates in Asia: New insights on the accuracy of survey forecasts. *Journal of Forecasting* 39: 313–33. [\[CrossRef\]](#)
- Laily, Vania Orva Nur, Budi Warsito, and Di Asih I. Maruddani. 2018. Comparison of ARCH/GARCH model and Elman Recurrent Neural Network on data return of closing price stock. Paper presented at 7th International Seminar on New Paradigm and Innovation on Natural Science and its Application, Semarang, Indonesia, October 17.
- León-Alvarez, Alba Luz, Jorge Iván Betancur-Gomez, Fabián Jaimes-Barragan, and Hugo Grisales-Romero. 2016. Ronda clínica y epidemiológica. Series de tiempo. *IATREIA* 29: 373–81. [\[CrossRef\]](#)
- Li, Nan, Liepeng Sun, Xiao Luo, Rong Kang, and Mingde Jia. 2019. Foreign trade structure, opening degree and economic growth in Western China. *Economies* 7: 56. [\[CrossRef\]](#)
- Liu, Li, Siming Tan, and Yudong Wang. 2020. Can commodity prices forecast exchange rates? *Energy Economics* 87. [\[CrossRef\]](#)
- Liu, Tao, and Wing Thye Woo. 2018. Understanding the U.S.-China trade war. *China Economic Journal* 11: 319–40. [\[CrossRef\]](#)
- Liu, Zhao Cheng, Xi Yu Liu, and Zi Ran Zheng. 2011. Modeling and prediction of the CNY exchange rates using RBF neural networks versus GARCH models. *Quantum, Nano, Micro and Information Technologies* 36: 375–82. [\[CrossRef\]](#)
- Lu, Xunfa, Danfeng Que, and Guangxi Cao. 2016. Volatility forecast based on the hybrid artificial neural network and GARCH-type models. Paper presented at Promoting Business Analytics and Quantitative Management of Technology: 4th International Conference on Information Technology and Quantitative Management, Asan, Korea, August 16–18; pp. 1044–49. [\[CrossRef\]](#)
- Ma, Guonan, and Robert N. McCauley. 2011. The implications of Renminbi basket management for Asian currency stability. *Frontiers of Economics and Globalization: Evolving Role of Asia in Global Finance* 9: 97–121. [\[CrossRef\]](#)
- Machova, Veronika, and Jan Marecek. 2019. Estimation of the development of Czech Koruna to Chinese Yuan exchange rate using artificial neural networks. Paper presented at SHS Web of Conferences–Innovative Economic Symposium 2018: Milestones and Trend of World Economy, Beijing, China, November 8–9; vol. 61. [\[CrossRef\]](#)
- Maggiore, Matteo, Brent Neiman, and Jesse Schreger. 2020. International currencies and capital allocation. *Journal of Political Economy* 128: 2019–66. [\[CrossRef\]](#)
- Mai, Yong, Huan Chen, Jun-Zhong Zou, and Sai-Ping Li. 2018. Currency co-movement and network correlation structure of foreign exchange market. *Physica A: Statistical Mechanics and Its Applications* 492: 65–74. [\[CrossRef\]](#)
- Maurer, Thomas A., Thuy-Duong Tô, and Ngoc-Khanh Tran. 2019. Pricing risks across currency denominations. *Management Science* 65: 5308–36. [\[CrossRef\]](#)
- Min, Yujuana, and Oh Suk Yang. 2019. The impact of exchange volatility exposure on firms' foreign-denominated debts. *Management Decision* 57: 3035–60. [\[CrossRef\]](#)
- Mohamed, Rania Ahmed Hamed. 2013. A comparison between the models ARIMA/GARCH and artificial neural networks in modelling financial returns to the Arab Republic of Egypt market securities. *Advances and Applications in Statistics* 36: 131–50.

- Narayan, Paresh Kumar, Susan Sunila Sharma, Ding Hoang Bach Phan, and Guangqiang Liu. 2020. Predicting exchange rate returns. *Emerging Markets Review* 42. [\[CrossRef\]](#)
- Nguyen, Thi-Ngoc Anh, and Kiyotaka Sato. 2020. Invoice currency choice, nonlinearities and exchange rate pass-through. *Applied Economics* 52: 1048–69. [\[CrossRef\]](#)
- Opie, Wei, and Steven J. Riddiough. 2020. Global currency hedging with common risk factors. *Journal of Financial Economics* 136: 780–805. [\[CrossRef\]](#)
- Ornelas, José Renato Haas, and Roberto Baltieri Mauad. 2019. Implied volatility term structure and exchange rate predictability. *International Journal of Forecasting* 35: 1800–13. [\[CrossRef\]](#)
- Ortiz Arango, Francisco. 2017. Prognosis of oil prices: A comparison between GARCH models and differential neural networks. *Investigacion Economica* 73: 105–26. [\[CrossRef\]](#)
- Parot, Alejandro, Kevin Michell, and Werner D. Kristjanpoller. 2019. Using artificial neural networks to forecast exchange rate, including VAR-VECM residual analysis and prediction linear combination. *Intelligent Systems in Accounting Finance & Management* 26: 3–15. [\[CrossRef\]](#)
- Petrica, Andreea Cristina, and Stelian Stancu. 2017. Empirical results of modelling EUR/RON exchange rate using ARCH, GARCH, EGARCH, TARCH and PARCH models. *Romanian Statistical Review* 57–72.
- Ponomareva, Natalia, Jeffrey Sheen, and Ben Zhe Wang. 2019. Forecasting exchange rates using principal components. *Journal of International Financial Markets, Institutions and Money* 63. [\[CrossRef\]](#)
- Quaicoo, Michael Techie, Frank B. K. Twenefour, Emmanuel M. Baah, and Ezekiel N. N. Nortey. 2015. Modeling variations in the cedi/dollar exchange rate in Ghana: An autoregressive conditional heteroscedastic (ARCH) models. *Springerplus* 4. [\[CrossRef\]](#)
- Rajković, Milos, Predrag Bjelić, Danijela Jaćimović, and Miroslav Verbič. 2020. The impact of the exchange rate on the foreign trade imbalance during the economic crisis in the new EU member states and the Western Balkan countries. *Economic Research-Ekonomiska Istraživanja* 33: 182–203. [\[CrossRef\]](#)
- Ramchoun, Hassan, Mohammed Amine Janati Idrissi, Youssef Ghanou, and Mohamed Ettaouil. 2017. New modeling of multilayer perceptron architecture optimization with regularization: An application to pattern classification. *IAENG International Journal of Computer Science* 44: 261–69.
- Ribeiro, Rafael S. M., John S. L. McCombie, and Gilberto Tadeu Lima. 2020. Does real exchange rate undervaluation really promote economic growth? *Structural Change and Economic Dynamics* 52: 408–17. [\[CrossRef\]](#)
- Salkind, Neil J. 2010. *Encyclopedia of Research Design*. Thousand Oaks: SAGE Publications. [\[CrossRef\]](#)
- Sheikhan, Mansour, Najmeh Mohammadi, and Robert Schaefer. 2013. Time series prediction using PSO-optimized neural network and hybrid feature selection algorithm for IEEE load data. *Neural Computing and Applications* 23: 1185–94. [\[CrossRef\]](#)
- Sindelarova, Irena. 2012. Exchange rate prediction: A wavelet-neural approach. Paper presented at 30th International Conference Mathematical Methods in Economics, Karvina, Czech Republic, September 11–13; pp. 875–78.
- Smallwood, Aaron D. 2019. Analyzing exchange rate uncertainty and bilateral export growth in China: A multivariate GARCH-based approach. *Economic Modelling* 82: 332–44. [\[CrossRef\]](#)
- Tian, Gary Gang, and Shiguang Ma. 2010. The relationship between stock returns and the foreign exchange rate: The ARDL approach. *Journal of the Asia Pacific Economy* 15: 490–508. [\[CrossRef\]](#)
- Turkington, David, and Alireza Yazdani. 2020. The equity differential factor in currency markets. *Financial Analysts Journal* 76: 70–81. [\[CrossRef\]](#)
- Vochozka, Marek, and Jaromir Vrbka. 2019. Estimation of the development of the Euro to Chinese Yuan exchange rate using artificial neural networks. Paper presented at SHS Web of Conferences—Innovative Economic Symposium 2018: Milestones and Trend of World Economy, Beijing, China, November 8–9; vol. 61.
- Vochozka, Marek, Jakub Horak, and Petr Suler. 2019. Equalizing seasonal time series using artificial neural networks in predicting the Euro-Yuan exchange rate. *Journal of Risk and Financial Management* 12: 76. [\[CrossRef\]](#)
- Vochozka, Marek, Zuzana Rowland, Petr Suler, and Josef Marousek. 2020. The influence of the international price of oil on the value of the EUR/USD exchange rate. *Journal of Competitiveness* 19: 167–90. [\[CrossRef\]](#)

- Vrbka, Jaromir, Petr Suler, Veronika Machova, and Jakub Horak. 2019. Considering seasonal fluctuations in equalizing time series by means of artificial neural networks for predicting development of USA and People's Republic of China trade balance. *Littera Scripta* 12: 178–93. [CrossRef]
- Wen, Tiange, and Gang-Jin Wang. 2020. Volatility connectedness in global foreign exchange markets. *Journal of Multinational Financial Management* 54. [CrossRef]
- World Bank. 2020. Official Exchange Rate. Available online: <https://data.worldbank.org/indicator/PA.NUS.FCRF> (accessed on 20 April 2020).
- Xing, Yuqing. 2018. Rising wages, yuan's appreciation and China's processing exports. *China Economic Review* 48: 114–22. [CrossRef]
- Yin, Dian, and Wanyi Chen. 2016. The forecast of USD/CNY exchange rate based on the Elman neural network with volatility updating. Paper presented at 35th Chinese Control Conference, Chengdu, China, July 27–29; pp. 9562–66. [CrossRef]
- You, Yu, and Xiaochun Liu. 2020. Forecasting short-run exchange rate volatility with monetary fundamentals: A GARCH-MIDAS approach. *Journal of Banking & Finance* 116. [CrossRef]
- Zhang, Gioqinang, and Michael Y. Hu. 1998. Neural network forecasting of the British Pound/US Dollar exchange rate: comparison of various architectures of neural networks. *Omega* 26: 495–506. [CrossRef]
- Zhang, Zhaoyong, and Kiyotaka Sato. 2012. Should Chinese Renminbi be blamed for its trade surplus? A structural VAR approach. *The World Economy* 35: 632–50. [CrossRef]

Publisher's Note: MDPI stays neutral with regard to jurisdictional claims in published maps and institutional affiliations.



© 2020 by the authors. Licensee MDPI, Basel, Switzerland. This article is an open access article distributed under the terms and conditions of the Creative Commons Attribution (CC BY) license (<http://creativecommons.org/licenses/by/4.0/>).

MDPI
St. Alban-Anlage 66
4052 Basel
Switzerland
Tel. +41 61 683 77 34
Fax +41 61 302 89 18
www.mdpi.com

Risks Editorial Office
E-mail: risks@mdpi.com
www.mdpi.com/journal/risks



MDPI
St. Alban-Anlage 66
4052 Basel
Switzerland

Tel: +41 61 683 77 34
Fax: +41 61 302 89 18

www.mdpi.com



ISBN 978-3-0365-0537-4