

Vartiainen, Hannu

**Working Paper**

## One-deviation principle in coalition formation

Discussion paper, No. 35

**Provided in Cooperation with:**

Aboa Centre for Economics (ACE), Turku

*Suggested Citation:* Vartiainen, Hannu (2008) : One-deviation principle in coalition formation, Discussion paper, No. 35, Aboa Centre for Economics (ACE), Turku

This Version is available at:

<https://hdl.handle.net/10419/233251>

**Standard-Nutzungsbedingungen:**

Die Dokumente auf EconStor dürfen zu eigenen wissenschaftlichen Zwecken und zum Privatgebrauch gespeichert und kopiert werden.

Sie dürfen die Dokumente nicht für öffentliche oder kommerzielle Zwecke vervielfältigen, öffentlich ausstellen, öffentlich zugänglich machen, vertreiben oder anderweitig nutzen.

Sofern die Verfasser die Dokumente unter Open-Content-Lizenzen (insbesondere CC-Lizenzen) zur Verfügung gestellt haben sollten, gelten abweichend von diesen Nutzungsbedingungen die in der dort genannten Lizenz gewährten Nutzungsrechte.

**Terms of use:**

*Documents in EconStor may be saved and copied for your personal and scholarly purposes.*

*You are not to copy documents for public or commercial purposes, to exhibit the documents publicly, to make them publicly available on the internet, or to distribute or otherwise use the documents in public.*

*If the documents have been made available under an Open Content Licence (especially Creative Commons Licences), you may exercise further usage rights as specified in the indicated licence.*

*Hannu Vartiainen*  
**One-deviation principle  
in coalition formation**

**Aboa Centre for Economics**

Discussion Paper No. 35  
Turku 2008



Copyright © Author(s)

ISSN 1796-3133

Turun kauppakorkeakoulun monistamo  
Turku 2008

*Hannu Vartiainen*  
**One-deviation principle  
in coalition formation**

**Aboa Centre for Economics**  
Discussion Paper No. 35  
September 2008

**ABSTRACT**

We study coalitional one-deviation principle in a framework à la Chwe (1994). The principle requires that an active coalition or any of its subcoalition will not benefit from a single deviation to a strategy that specifies, for each history of coalitional moves, an active coalition and its move. A strategy meeting the one-deviation property is characterized. Moreover, it is shown to exist. Finally, the results are compared to the existing theories of coalitional games.

JEL Classification: C71, C72

Keywords: one-deviation principle, coalition formation

## **Contact information**

Turku School of Economics, Department of Economics,  
Rehtorinpellonkatu 3, FIN-20500 Turku.  
E-mail: hannu.vartiainen(a)tse.fi.

## **Acknowledgements**

I thank Hannu Salonen for useful discussions.

# 1 Introduction

Dating back at least to Harsanyi (1974), coalitional solutions have been criticized for not being able to take into account counterfactuals. That is, in answering satisfactorily - without ad hoc assumptions - what will happen once a coalitional action has taken place. Should a deviation be followed by further deviations? Uncertainty of this leads to a well known prediction problem: the deviant coalition may not know what the consequence, and hence the profitability, of its deviation is. This criticism has given borne to an important literature on the logic of coalitional behavior (for an illuminating exposition of this literature, see the recent work by Rey, 2006).

The problem is that, as the players should know what the modeler does, the players should anticipate any further future deviations following the initial deviation. Since the players are only concerned about the outcome that is to be implemented, they need to have a theory in mind what will the sequence of deviations be. Thus given such theory, there is an *indirect dominance* relation between outcomes where an outcome is dominated if there is a coalition that prefers blocking given the outcome that will be implemented after the deviation. The solution concept should be robust against such *farsighted* deviations. Since the theory of deviations is build into the theory, it is not clear how such modelling should be conducted. Qualitatively different solution concepts are obtained. The problem is particularly acute when the core is empty - which is often the case - and one is forced rely on equilibrium reasoning, in particular the von Neumann-Morgenstern stable set solution.

It is clear that the solution should reflect dynamic consistency in the sense of dynamic non-cooperative solution concepts. The key problem is, however, that the coalitional set up is not a proper non-cooperative game. The crucial difference is that the order of coalitional moves is typically not well specified. Any attempt to do this has seems to lead to either ad hoc assumptions of what is feasible for coalitions and what is not, or to indeterminacy problems. The desiderata one would want to put on succesful solutions are at least: (i) a solution should not force coalitions to accept an unacceptable outcome and (ii) the coalitions should be able to reconsider their choices subject to the past behavior. Putting together, at the heart of the matter is a commitment problem: the decision of stopping the game can potentially be reversed at any stage of the game.

Many ffarsighted solutions have been suggested in the literature. In particular, Harsanyi (1974) and Chwe (1994) analysed stable set with indirect dominance as the blocking criterion. One problem is that the solution often fails to exist. Another is that indirect dominance is also subject to a second degree credibility problem. Namely there is no way to ensure that the

coalitions in the middle follow the dominance path, especially if a deviation is profitable.<sup>1</sup>

One of the most useful conceptual systems is due to Chwe (1994). His framework allows description of coalitional game form in the sense that what may happen after a coalitional move is built into the structure of the game. The framework permits many interpretations, including classical cooperative games, networks, clubs, etc.. Chwe's system is, however, difficult to analyze as it is a graph without a clear recursive structure. His solution, the largest consistent set, has been used widely (e.g. Page et al, 2005) even though it has been argued to be too permissive (Xue, 1998). However, sharper solutions have consistently suffered from existence problems (see e.g. Barbera and Gerber 2007).

This paper develops a new coalitional solution in the framework of Chwe (1994). The solution is based on two observations: (i) The underlying game structure of coalitional games is isomorphic to simple recursive games; infinite horizon games in which only one player moves at a time and all players' payoffs depend on the node at which the play is stopped by the moving player. Analyzing such games by noncooperative means is the appropriate way to guarantee farsightedness of the decision makers and internal consistency of the model. (ii) The existing results on recursive games are insufficient: it is not known whether an equilibrium in recursive games exist nor even what is the appropriate solution concept. Our aim is to fill this gap and, *a fortiori*, suggest a contradiction-free foundation for coalitional games.

The natural solution concept for this class of games is the *one deviation principle*: after any history should a moving coalition not want to make a one time deviation to his strategy. The property is not derived as consequence of other dynamic solution concepts but rather it is taken as the primitive. It can be interpreted as a consequence of a computational constraint: players are suggested their equilibrium strategies on which they can compute any number of changes but *not* infinitely many changes.

We show that a strategy meeting the criterion that always implements an outcome in finite time exists for any Chwe-game with finitely many physical outcomes. The equilibrium play paths are characterized and the equilibrium outcomes specified. The equilibrium characterization is based on iterative application of a *majorization* operations, familiar from the social choice literature.

Finally, we compare the solution with the largest consistent set of Chwe. It is shown that the one-deviation solution is always contained by the largest

---

<sup>1</sup>Aumann and Maschler (1974) is another older attempt to solve the commitment problem.

consistent set. We also relate our model to Xue's (1998) solution which is based on the same primitive idea of comparing blockings over paths rather than outcomes. It is shown that the two solutions bear much similarities. However, to my knowledge the existence of Xue's solution can be guaranteed only in special cases. Finally we interpret the results in a general framework of Konishi and Ray (2003) where blocking takes place in real time. We show that our model can be interpreted as an extension of theirs.

Other recent contributions include Vanneltbosch et al. (2008), Barbera and Gerber (2001), Diamantoudi and Xue (2007). Greenberg (1991) gives a useful taxonomy of the principles that govern strategic behavior. This paper has been inspired by this approach.

## 2 Coalitional game

A *coalitional game* due to Chwe (1994) is defined by the list  $\Gamma = \langle N, X, (F_S)_{S \subseteq N}, (\succsim_i)_{i \in N} \rangle$ , where  $N$  is the finite set of players,  $X$  is the nonempty finite set of vertices or nodes, the action set  $F_S : X \rightarrow 2^X$  specifies the set of actions  $F_S(x) \subseteq X$  available to coalition  $S \subseteq N$  at node  $x \in X$ .<sup>2</sup> We assume  $x \in F_S(x)$  for all  $x$  and for all  $S$ . Each player  $i \in N$  has a preference relation  $\succsim_i$  over the set of outcomes  $X$ .

Using the language of cooperative game theory, one might interpret an outcome  $x$  to be the description of a coalition structure, as well as a vector of payoffs accruing to each player. In noncooperative games in strategic form, an outcome would represent a profile of actions taken in the stage game.

The Chwe-game is played in the following manner: There is the initial status quo  $x^*$ . At any stage  $t = 0, 1, \dots$ , the outcome  $x_t$  is the current status quo. The status quo can be changed by a coalition. Only *one* coalition may be active at a time. If coalition  $S$  is active and chooses  $y \in F_S(x_t) \setminus \{x_t\}$ , then  $y$  becomes the new status quo at stage  $t + 1$ . If  $y = x_t$ , then  $x_t$  is implemented.

The reason for why only one coalition may be active at a time is that game is meant to describe the coalition formation *process*. If the activity of a coalition  $S$  is to induce activity from the the part of other coalitions, then that should be reflected by the graph  $(X, (F_S)_{S \subseteq N})$ . They should be interpreted as the primitive of the model, game form, and the activation plan of the coalitions as their strategy which should, presumably, meet the desired stability properties.

---

<sup>2</sup>Chwe (1994) does not assume finite outcome space.



**Paths** A *path* is a *finite* sequence  $(x_0, \dots, x_K) \in \cup_{k=1}^{\infty} X^k$  such that  $x_{k+1} \in F_S(x_k) \setminus \{x_k\}$  for some  $S$ , for all  $k = 0, \dots, K$ , and  $x_K \in Z$ . The *length* of the path  $(x_0, \dots, x_K)$  is  $K$ ; the number of its edges. A path is abbreviated by an upper bar above a typical node:  $\bar{x} = (x_0, \dots, x_K)$ . Denote by  $\bar{X}$  the set of all paths.

Our notational conventions concerning paths are: Generic components of  $\bar{x}$ ,  $\bar{y}$ , and  $\bar{z}$  are denoted  $x$ ,  $y$ , and  $z$ , respectively. The path that is obtained by truncating  $\bar{x} = (x_0, \dots, x_K) \in \bar{X}$  at the  $k^{\text{th}}$  step is  $\bar{x}_k = (x_0, \dots, x_k)$ . The path that is obtained by joining a truncated path  $\bar{x}_k = (x_0, \dots, x_k)$  and a path  $\bar{y} = (y_0, \dots, y_L)$  is  $\bar{x}_k \bar{y} = (x_0, \dots, x_k, y_0, \dots, y_L)$ . Then also  $\bar{x}_k \bar{y}_l \bar{z} = (x_0, \dots, x_k, y_0, \dots, y_l, z_0, \dots, z_M)$ , where  $\bar{z} = (z_0, \dots, z_M)$ , and so forth.

**Strategies** Denote the set of nonterminal histories by

$$H := \{(x_0, S_0, x_1, \dots, S_{T-1}, x_T) : x^* = x_0 \text{ and } x_{t+1} \in F_{S_t}(x_t), \text{ for all } t \leq T \text{ and } T = 0, \dots\}.$$

Define by function  $S : H \rightarrow 2^N$  the activation plan of coalitions. Then coalition  $S(h, x)$  is active after history  $(h, x)$ , for any  $(h, x) \in H$ . A coalitional strategy  $\sigma$  is conditional on history  $(h, x) \in H$  such that  $\sigma(h, x) \in F_{S(h,x)}(x)$ . Let  $\sigma^0(h, x) = \sigma(h, x)$  and  $\sigma^t(h, x) = \sigma^{t-1}(h, x, \sigma(h, x))$ , for all  $t = 1, \dots$ . Denote by  $\bar{\sigma}(h)$  the sequence of nodes induced by strategy  $\sigma$  from history  $h$  onwards:

$$\bar{\sigma}(h) = (\sigma^0(h), \sigma^1(h), \dots)$$

If there is  $T$  such that  $\sigma^T(h) = \sigma^{T+1}(h)$ , then  $\bar{\sigma}(h, x_0) = (x_0, \dots, x_T)$  where  $x_t = \sigma^t(h)$ , for  $t = 0, \dots, T$ .

Denote the final element of the path  $(x_0, \dots, x_K)$  by  $\pi[(x_0, \dots, x_K)] = x_K$ . We say that the strategy  $\sigma$  is *well defined* if  $\pi[\bar{\sigma}(h)]$  exists for all  $h \in H$ , i.e., an outcome is implemented in finite time after any history. Then  $\pi[\bar{\sigma}(h, x)]$  is the outcome implemented when a well defined strategy  $\sigma$  is followed after history  $(h, x)$ , and  $\pi[\bar{\sigma}(h, x, a)]$  is the outcome that becomes implemented if coalition  $S$  chooses action  $a \in F_S(x)$  and  $\sigma$  is followed thereafter:

$$\pi[\bar{\sigma}(h, x, S, a)] = \begin{cases} \pi[\bar{\sigma}(h, x, S, y)], & \text{if } a = y \neq x, \\ x, & \text{if } a = x. \end{cases} \quad (1)$$

In particular, if  $a = \sigma(h)$ , then  $\pi[\bar{\sigma}(h, a)] = \pi[\bar{\sigma}(h)]$ .

**Solution** We use the notation: for any  $S \subseteq N$ , and  $x, y \in X$ ,

$$y \succ_S x \text{ if } y \succ_i x, \text{ for all } i \in S,$$

and

$$y \succ_S x \text{ if } y \succ_i x, \text{ for all } i \in S, \text{ and } y \succ_j x \text{ for some } j \in S.$$

Our focus is on agents that can compute in finite time which outcome will become implemented given the players' strategies. Hence we confine attention on strategies that are well defined. Our equilibrium condition is the following.

**Definition 1 (One-Deviation Property)** *A well defined strategy  $(\sigma, S)$  satisfies the coalitional one-deviation property if  $\sigma(h, x) = x$  implies  $S(h, x) = N$  and*

$$\pi[\bar{\sigma}(h, S, a)] \not\succeq_S \pi[\bar{\sigma}(h)], \text{ for all } a \in F_S(x), \text{ for all } S \subseteq S(h), \text{ for all } h \in H.$$

That is, after any history, a single coalition is active. The active coalition nor any of its subcoalition can make a single deviation that is profitable for all coalition members given the continuation play. Note that implementation of an outcome requires that the active coalition is the grand coalition the grand coalition.

Our aim is to characterize equilibrium behavior and prove the existence of an equilibrium meeting the one-deviation property. The collection of equilibrium paths

$$\bar{\sigma}(H) = \{\bar{x} : \bar{\sigma}(h) = \bar{x}, \text{ for some } h \in H\}$$

is our main object of our study. The collection also defines the set of outcomes that are implementable via a finitely long deviation to  $\sigma$  by the operation  $\pi[\bar{\sigma}(H)]$ . The initial status quo may affect the eventual outcome that will become implemented in the maximal set of implementable outcomes but not the set itself.

### 3 Characterization

Farsighted players should anticipate further movement and care only of the final outcome (see Harsanyi, 1974). A feasible path reflects a potential play path, given the starting status quo  $x_0$ . The final outcome is the potentially implemented outcome. We will work in terms of feasible paths. Denote by  $\bar{X}$  the collection of all feasible paths in  $X$ .

**Definition 2 (Coalitional Dominance)** *A path  $\bar{y} \in \bar{X}$  dominates a path  $\bar{x} \in \bar{X}$  at the  $k^{\text{th}}$  step, denoted by  $\bar{y} \triangleright_k \bar{x}$ , if  $x_{k+1} \neq y_0$  if there is  $S$  such that  $y_0 \in F_S(x_k)$  and, for any such  $S$ , there is an  $S'$  such that  $S' \subseteq S$ ,  $x_{k+1} \in F_{S'}(x_k)$ , and  $\pi[\bar{y}] \succ_{S'} \pi[\bar{x}]$ .*

That is, if outcome  $x_k$  is reached along the feasible chain  $x$ , then there is a player who participates an active coalition at  $x_k$  that rather joins a new coalition that benefits from path  $\bar{y}$  more than path  $\bar{x}$ , provided that the end points of them are reached. The key feature of the definition is that an active coalition  $S'$  can be blocked only by a subcoalition  $S \subseteq S'$ . Note that if  $x = (x_0, \dots, x_n)$  dominates  $\bar{y}$  and  $n = 0$ , then  $\pi[\bar{x}] = x_0$ .

Define paths that begin from node  $y$  by

$$\bar{X}_y = \{\bar{y} \in \bar{X} : y_0 = y\}.$$

**Definition 3 (Consistent Collection of Paths)** *A consistent collection of paths  $CCP \subseteq \bar{X}$  satisfies:*

- (i) *For any  $x \in X$ , there is  $\bar{x} \in CCP$  such that  $x = x_0$ .*
- (ii) *For any  $\bar{x} \in CCP$ , there is no  $y, S$ , and  $k$  such that  $\bar{y} \triangleright_k \bar{x}$  for all  $\bar{y} \in CCP$  such that  $y_0 = y$ .*

That is, for any initial status quo node, there is a feasible path in the consistent collection that answers how the play will evolve. Finally, if a player whose turn it is to move deviates from the path, then there is a path in  $\bar{Y}$  starting from the new node that does *not* improve the deviating player's payoff relative to what he would get if the original path is followed. A consistent collection of paths thus describes a stability property: any deviation from a stable play path can be credibly punished.

Now we establish that a consistent collection of paths characterizes equilibrium behavior, i.e., that any collection of equilibrium paths is equivalent to a consistent collection of paths.

**Lemma 4** *Let a well defined  $\sigma$  satisfy the one-deviation property. Then  $\bar{\sigma}(H)$  is a CCP.*

**Proof.** (i). Find a path  $(x_0, \dots, x_k)$  such that  $x_k = x$ . Then  $\bar{\sigma}(x_0, \dots, x_{k-1}, x) \in \bar{\sigma}(H)$ .

(ii). Take any  $(h, x_0) \in H$  and the equilibrium path  $\bar{\sigma}(h, x_0) = x$ . Let  $y \in F_S(x_k) \setminus \{x_{k+1}\}$  for any  $S \subseteq S(h, x_0)$ . Since  $S$  chooses in equilibrium  $x_{k+1}$  rather than  $y$ , there is a path  $\bar{y} = \bar{\sigma}(h, x_k, y)$  that  $S$  does not strictly prefer over the equilibrium path  $\bar{x}$ , i.e.  $\pi[\bar{y}] \not\prec_S \pi[\bar{x}]$ . ■

Now we show the converse - that for any consistent collection of paths there exists a well defined strategy meeting the one-deviation property. Let  $\bar{Y}$  be a consistent collection of paths. Identify a function  $\phi$  on  $\bar{Y} \times X \times \mathbb{N}$

such that  $\phi(x, y, k) = \bar{y} \in \bar{Y}$  and  $y_0 = y$ ,  $\bar{y} \not\prec_k x$  whenever  $y \in F(x_k) \setminus \{x_{k+1}\}$ . Since *CCP* satisfies Condition ??, such function exists.

Fix a consistent collection of paths *CCP*. Construct a strategy  $(\sigma^* : f, Q)$  where  $\sigma^*$  specifies the action,  $Q$  is the set of *states* on which the strategy operates, and  $f$  is a *transition function* from  $Q \times X$  to  $Q$ . Let

$$Q = \{q^{\bar{x}} : \bar{x} \in CCP\}, \quad (2)$$

be a set of states summarizing histories in  $H$  as follows: For any sequence  $\bar{x} = (x_0, \dots) \in H$ , let the transition function  $f$  satisfy, for any  $k = 0, \dots$ ,

$$f(q^{\bar{x}}, x_0, \dots, x_k, y) = \begin{cases} q^{\bar{x}}, & \text{if } y = x_{k+1}, \\ q^{\phi(x, y, k)}, & \text{if } y \neq x_{k+1}. \end{cases} \quad (3)$$

Proceeding this way for all  $x \in X$ , and for all  $k = 0, 1, \dots$ , each element of  $H$  is allocated into one element of  $Q$ .

Let the strategy  $\sigma^*$  be conditional on the current state  $q^{\bar{x}}$  and the node  $x_k$ , and satisfy

$$\sigma_{I(x_k)}^*(q^{\bar{x}}, x_k) = \begin{cases} x_{k+1}, & \text{if } x_{k+1} \text{ exists,} \\ x_k, & \text{if } x_{k+1} \text{ does not exist.} \end{cases} \quad (4)$$

That is, the strategy calls the moving player to continue along the path  $\bar{x} = (x_0, \dots, x_K)$  and implement  $x_K$  when the end of the path is reached.

**Lemma 5** *Strategy  $\sigma^*$  is well defined and satisfies the one-deviation property.*

**Proof.** Starting from  $x_0 = x^*$ , recursive application of (3) and (4) and the construction of  $Q$  imply that  $\sigma$  is well defined.

To check the one-deviation property, take any  $\bar{x} = (x_0, \dots)$ . For any  $k$ , a deviation to  $y \in F(x_k) \setminus \{x_{k+1}\}$ , induces a path  $\phi(x_k, y, k) = \bar{z}$  such that  $z_0 = y$  and  $\bar{z} \not\prec_k \bar{x}$ . By the definition of dominance,  $\pi[\bar{x}] \succ_{I(x_k)} \pi[\bar{z}]$ . Thus a unilateral deviation to  $y$  is not profitable for player  $I(x_k)$ . ■

By Lemmata 4 and 5, a well defined equilibrium strategy induces behavior consistent with a consistent collection of paths and behavior in any consistent collection of paths can be supported by a well defined equilibrium strategy. We compound these observations in the following characterization.

**Theorem 6** 1. *For any well defined strategy  $\sigma$  satisfying the one-deviation property there is a consistent collection of paths *CCP* such that  $\bar{\sigma}(H) = CCP$ .*

2. *For any consistent collection of paths *CCP* there is a well defined  $\sigma$  satisfying the one-deviation property such that  $CCP = \bar{\sigma}(H)$ .*

This result does not, however, tell anything about the existence of a consistent collection of paths nor how it can be identified. The next section provides an algorithm for identifying the maximal consistent collection of paths. Hence it also guarantees the existence of a solution.

### 3.1 Existence

The aim of this subsection is to prove that a consistent collection of paths and, *á fortiori*, that a well defined equilibrium strategy exists. For this we need to define the following relation between paths and nodes. The concept is inspired by its cousin in the social choice literature (cf. Fishburn, 1977; Miller, 1980; Dutta, 1988, or Laslier, 1991). Let  $\bar{B}$  be subset of  $X$ .

**Definition 7** *Path  $\bar{x}$  is pseudo-covered in  $\bar{B}$  via node  $y$  if there is  $k$  such that  $\bar{y} \triangleright_k \bar{x}$  for all  $\bar{y} \in \bar{X}_y \cap \bar{B}$ . If, moreover,  $\bar{x} \in \bar{B}$ , then  $\bar{x}$  is covered in  $\bar{B}$  via  $y$ .*

That is, a feasible path  $\bar{x}$  is pseudo-covered in  $\bar{B}$  of paths if, at some node  $x_k$ , the moving player  $I(x_k)$  cannot lose by deviating from the path  $\bar{x}$  to node  $y$ , given the hypothesis that the continuation play belongs to the set  $\bar{B}$ . If, furthermore,  $\bar{x}$  itself is an element of  $\bar{B}$ , then  $\bar{x}$  is said to be covered in  $\bar{B}$ .

Denote by  $UC(\bar{B})$  the *uncovered* set of  $\bar{B}$ , i.e. the set of parths not covered in  $\bar{B}$ . By construction,  $UC(\bar{B}) \subseteq \bar{B}$ .

We now strengthen of the uncovered set -concept by iterating the uncovered-operator until no paths are left to be covered. The *ultimate uncovered set*  $UUC$  is defined recursively as follows. Set  $UC^0 = \bar{X}$ , and let  $UC^{t+1} = UC(UC^t)$ , for all  $t = 0, \dots$ . Then  $UC^\infty$  is the ultimate uncovered set.  $UC^\infty$  is nonempty only if  $UC^t$  is nonempty for all  $t$ . Let  $UC^\infty := UUC$ .

Before we establish the existence of the ultimate uncovered set  $UUC$ , we reduce the complexity of information hidden in dominance relationships.

**Definition 8 (Dominance Class)** *A dominance class  $D^{(Y,y)}$  of paths is indexed by a pair  $(Y, y) \in 2^X \times Z$ . Path  $\bar{x} = (x_0, \dots, x_K)$  belongs to a dominance class  $D^{(Y,y)}$  if  $(\{x_k\}, \pi[\bar{x}]) = (Y, y)$ .*

A dominance class contains all the relevant information concerning dominance: If two paths  $\bar{x}$  and  $\bar{x}'$  belong to the same dominance class, then  $\bar{y} \triangleright_k \bar{x}$  for some  $k$  if and only if  $\bar{y} \triangleright_{k'} \bar{x}'$  for some  $k'$ ; the length of the path or how many times it cycles in the middle does not matter. Since  $X$  is a finite set, and  $Z \subseteq X$ , the number of dominance classes is finite. Dominance classes partition the set of paths  $\bar{X}$ .

We say that a dominance class  $D^{(Y,y)}$  *subsumes* a dominance class  $D^{(Y',y')}$  if  $y = y'$  and  $Y' \subseteq Y$ . Let  $D^{(Y,y)}$  subsume  $D^{(Y',y')}$ . Take  $\bar{x} \in D^{(Y,y)}$  and  $\bar{x}' \in D^{(Y',y')}$ . Then, for any  $\bar{y}, \bar{y}' \triangleright_k \bar{x}$  for some  $k$  whenever  $\bar{y} \triangleright_{k'} \bar{x}'$  for some  $k'$ . The following result is an immediate corollary of this observation.

**Lemma 9** *If the dominance class containing  $\bar{x}$  subsumes the dominance class containing  $\bar{x}'$ , then  $\bar{x}$  is pseudo-covered in  $UC^t$  if  $\bar{x}'$  is pseudo-covered in  $UC^t$ , for all  $t = 0, \dots$ .*

Since  $x$  is subsumed by any path from which one has simply removed all cycles, if  $x$  is not pseudo-covered in  $UC^t$  then any acyclic path that it subsumes is not pseudo-covered in  $UC^t$ . Now we state the main result of the paper.

**Lemma 10** *For any  $t = 0, \dots$ , if  $\bar{x} \in UC^t$  such that  $x_0 = x$ , then there is  $\bar{y} \in UC^{t+1}$  such that  $y_0 = x$ .*

**Proof.** First, index all the nodes in  $X$  with natural numbers. Further, index all paths of  $\bar{X}$  such that of any two paths, the longer always has a higher index. Since  $X$  contains finitely many elements, such indexing can be performed.<sup>3</sup>

The proof is by contradiction. By assumption, there is an acyclic  $\bar{x} \in UC^0$  such that  $x_0 = x$ . Suppose that  $t$  is the first stage at which the lemma does *not* hold true. Then  $\bar{x}$  is pseudo-covered in  $UC^t$ . Construct recursively a sequence  $\bar{y}^0, \bar{y}^1, \dots$  of paths as follows:

Let  $\bar{x} = \bar{y}^0$ . Given  $\bar{y}^n$ ,  $n = 0, 1, \dots$ , let  $k_n$  be the first step at which  $\bar{y}^n$  is pseudo-covered and let  $x$  be the node with the smallest index among the nodes via which  $\bar{y}^n$  is pseudo-covered at  $k_n$ . Let  $\bar{x}^n$  be the one with the smallest index among all  $\bar{x} \in UC^j$  such that  $x_0 = x$ . Since the lemma holds for stages smaller than  $t$ , such  $\bar{x}^n$  exists. By Lemma 9,  $\bar{x}^n$  is acyclic and hence its length is at most  $|X|$ . Finally, let  $\bar{y}^{n+1} = \bar{y}_{k_n}^n \bar{x}^n$ . (See Figure 1 for an example of paths  $\bar{y}^0, \dots, \bar{y}^7$ , each starting from  $x$ )

---

<sup>3</sup>Letting  $\lambda : V \rightarrow \mathbb{N}$  be an indexing of  $v$ , an example of such indexing  $\theta : \bar{V} \rightarrow \mathbb{N}$  is  $\theta(\bar{v}) = \sum_{k=0}^K \lambda(v_k) |V|^k$ , for all  $\bar{v} = (v_0, \dots, v_K)$ . It is easy to see that  $\theta(v_0, \dots, v_K) > \theta(v'_0, \dots, v'_{K'})$  if  $K > K'$ .

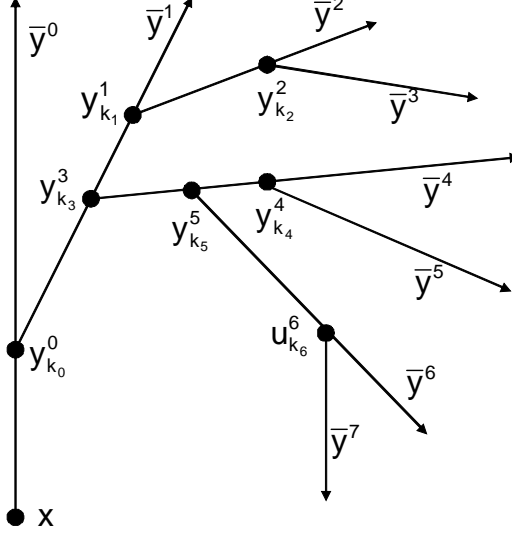

Figure 1

We now develop a characterization of a path  $\bar{y}^n$  in terms of the acyclic paths  $\bar{x}^0, \dots, \bar{x}^{n-1}$ . The pseudo-covering steps  $k_0, k_1, \dots \in \mathbb{N}$  are well defined by the sequence  $\bar{y}^0, \dots$ . For any  $n = 0, 1, \dots$ , determine recursively a set of indices  $S = \{s_0, \dots\} \subseteq \{0, \dots, n\}$ : Let

$$s_0 = \arg \min_{s \in \{0, \dots, n\}} k_s$$

and, given  $s_0, \dots, s_j$ ,

$$s_{j+1} = \arg \min_{s \in \{s_j, \dots, n\}} k_s, \text{ for all } j = 0, \dots. \quad (5)$$

Then there is  $q \leq n$  such that  $s_q = n$  and

$$k_{s_0} < \dots < k_{s_q}.$$

For example, in Figure 1,  $n = 2$  implies  $S = \{0, 1, 2\}$ , and  $n = 6$  implies  $S = \{0, 3, 5, 6\}$ . Writing  $d_0 = k_{s_0}$  and  $d_j = k_{s_j} - k_{s_{j-1}}$  for all  $j \geq 1$ , permits us to express the path  $\bar{y}^{n+1} = \bar{y}^{s_q+1}$  as

$$\bar{y}^{s_q+1} = \bar{x}_{d_0} \bar{x}_{d_1}^{s_0} \dots \bar{x}_{d_q}^{s_{q-1}} \bar{x}^{s_q}. \quad (6)$$

Since  $q \leq n$ , (5) and (6) imply more generally that

$$\bar{y}^{s_j+1} = \bar{x}_{d_0} \bar{x}_{d_1}^{s_0} \dots \bar{x}_{d_j}^{s_{j-1}} \bar{x}^{s_j}, \text{ for all } j = 0, \dots, q. \quad (7)$$

The first step  $k_{s_j}$  at which  $\bar{y}^{s_j}$  is pseudo-covered is now  $k_{s_j} = d_0 + \dots + d_j$ . The node at which this takes place is  $y_{k_{s_j}}^{s_j}$ .

Now we prove the contradiction via a series of subclaims.

*Claim 1.* The sequence  $\bar{y}^0, \dots$  does not have a top element, i.e., for all  $n = 0, 1, \dots$ , the path  $\bar{y}^n$  is pseudo-covered in  $UC^t$ .

*Proof:* Suppose, to the contrary, that the sequence  $\bar{y}^0, \dots$  has a top element  $\bar{y}^m$ . Since the lemma holds for steps smaller than  $t$ , and since  $\bar{y}^m$  is not pseudo-covered in  $UC^t$ , it must be the case that  $\bar{y}^m \in UC^t$ . Since  $\bar{y}^m$  is not covered in  $UC^t$ , in fact,  $\bar{y}^m \in UC^{t+1}$ . But  $x = x_0 = y_0^m$  contradicts the assumption that the lemma does not hold true at stage  $t$ .

*Claim 2.* The length of paths  $\bar{y}^0, \dots$  is uniformly bounded by  $|X|^2$ .

*Proof:* Let, to the contrary of the claim,  $\bar{y}^{n+1}$  be a path with the length  $K$  higher than  $|X|^2$ . Decompose  $\bar{y}^n$  as in (6):

$$\bar{y}^{n+1} = \bar{x}_{d_0} \bar{x}_{d_1}^{s_0} \dots \bar{x}_{d_q}^{s_{q-1}} \bar{x}^{s_q}.$$

Since  $\bar{y}^{n_0}$  consists of  $q$  truncated paths  $\bar{x}^s$  whose length before truncation is at most  $|X|$ , it must be that  $q \cdot |X| \geq K$ . By assumption,  $K \geq |X|^2 + 1$ . Thus  $q \geq |X| + 1$ . By the pigeonhole principle,  $y_{k_{s_m}}^{s_m} = y_{k_{s_l}}^{s_l}$  for some  $0 \leq l, m \leq q$  and  $s_l < s_m$ . By (7),

$$\bar{y}^{s_m+1} = \bar{x}_{d_0} \bar{x}_{d_1}^{s_0} \dots \bar{x}_{d_m}^{s_{m-1}} \bar{x}^{s_m}.$$

But  $s_l < s_m$  contradicts the assumption that  $d_0 + \dots + d_l + \dots + d_m$  is the first step at which  $\bar{y}^{n_m}$  is pseudo-covered (since  $\bar{y}^{n_m}$  is pseudo-covered also at step  $d_0 + \dots + d_l$ ).

*Claim 3.* There is a set of paths  $\{\bar{z}^0, \dots, \bar{z}^p\}$  in which the sequence  $\bar{y}^0, \dots$  ends up cycling.

*Proof:* By Claim 1,  $\bar{y}^0, \bar{y}^1, \dots$  is an infinite sequence. By construction, at the  $n^{\text{th}}$  step the transition from  $\bar{y}^n$  to  $\bar{y}^{n+1}$  is contingent only on  $\bar{y}^n$ . Since the length of paths  $\bar{y}^0, \bar{y}^1, \dots$  is uniformly bounded by Claim 2, and hence the paths are drawn from a finite set, we can view  $\bar{y}^0, \dots$  as a (deterministic) finite state Markov process. Interpreting  $\{\bar{z}^0, \dots, \bar{z}^p\}$  as the *ergodic set* of the



process proves the claim.

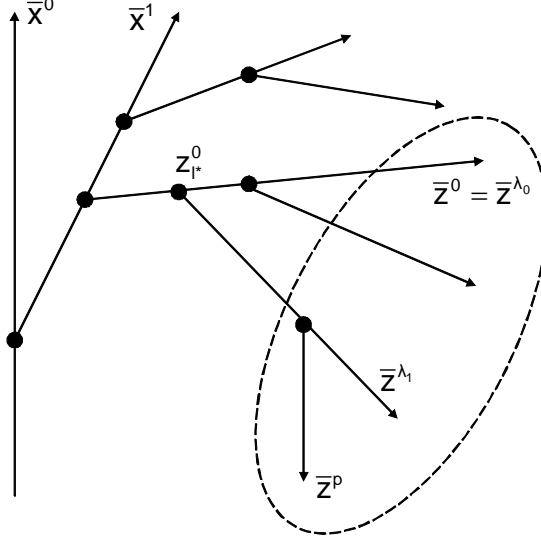

Figure 2

*Claim 4.* The assumption that the lemma does not hold true at stage  $t$  is not true.

*Proof:* By Claim 3, let the steps at which  $\bar{z}^0, \dots, \bar{z}^p$  are pseudo-covered be  $l_0, \dots, l_p$ , respectively. Assume that  $l^* = \min_{l=0, \dots, p} l_l$ . By construction,  $\bar{z}^0, \dots, \bar{z}^p$  agree up to step  $l^*$ , from which onwards they diverge into at least two branches. Let  $\{\lambda_0, \dots, \lambda_q\} \subseteq \{0, \dots, p\}$  be the (unique) indexation such that, for given  $\lambda_j$ ,  $\lambda_{j+1}$  is the smallest integer such that  $z_{l^*+1}^{\lambda_j} \neq z_{l^*+1}^{\lambda_{j+1}}$  for all  $j = 0, \dots, q$ . Since the ordering  $\bar{z}^0, \dots, \bar{z}^p, \bar{z}^0$  is derived from the pseudo-covering operation,  $\bar{z}_{l^*+1}^\xi \triangleright_{l^*} \bar{z}^{\lambda_{j-1}}$  for all  $\lambda_j \leq \xi \leq \lambda_{j+1} - 1$ , and  $j = 1, \dots, q$ , and  $\bar{z}_{l^*+1}^\xi \triangleright_{l^*} \bar{z}^{\lambda_q - 1}$ , for all  $\xi \leq \lambda_0 - 1$  or  $\lambda_q \leq \xi$ . By chaining the coalitional dominance relations, for any  $S_j$  such that  $z_{l^*+1}^{\lambda_{j-1}} \in F_{S_j}(z_{l^*})$  there is a  $S'_j \subseteq S_j$  such that  $z_{l^*+1}^{\lambda_j} \in F_{S'_j}(z_{l^*})$ . Thus, after fixing  $S_0$  there is a sequence of nonempty coalitions  $S_0 \supseteq S_1 \supseteq \dots$  such that for any  $\varphi = j \pmod{q}$ , it holds that  $z_{l^*+1}^{\lambda_{\varphi-1}} \in F_{S_j}(z_{l^*})$ . Since all coalitions are nonempty, there  $i \in S_j$  for all  $j = 0, 1, \dots$ . Then, by the definition of dominance,  $\pi[\bar{z}^\xi] \succ_i \pi[\bar{z}^{\lambda_{j-1}}]$  for all  $\lambda_j \leq \xi \leq \lambda_{j+1} - 1$  and  $j = 0, \dots, q - 1$ . Moreover,  $\pi[\bar{z}^\xi] \succ_i \pi[\bar{z}^{\lambda_q - 1}]$ , for all  $\xi \leq \lambda_0 - 1$  or  $\lambda_q \leq \xi$ . But this violates the transitivity of  $\succ_i$ , a contradiction. ■

Now we argue that the ultimate uncovered set is a well defined concept.

**Lemma 11** *There is  $T < \infty$  such that  $UC^T = UUC$ .*

**Proof.** By Lemma 9, all paths in the same dominance class become covered at the same covering round  $t$ . Since there are finitely many dominance classes, the number of covering rounds to reach  $UUC$  must be finite. ■

By induction, Lemma 10 implies that if  $\bar{z}$  is covered in  $UC^t$ , then  $\bar{z}$  is in  $UC^T$  such that  $x_0 = y_0$ . The following corollary generalizes this idea.

**Corollary 12** *For any  $t = 0, \dots$ , if  $\bar{x} \in UC^t$  such that  $x_0 = x$ , then there is  $\bar{y} \in UUC$  such that  $y_0 = x$ .*

By construction, no element in  $UUC$  is covered in  $UUC$ . Now we prove that  $UUC$  satisfies the two properties of consistent collection of paths.

**Theorem 13**  *$UUC$  is a consistent collection of paths.*

**Proof.** (i). By assumption, there is  $\bar{x} \in UC^0$  such that  $x_0 = x$ . By Corollary 12, there is  $\bar{y} \in UUC$  such that  $y_0 = x$ .

(ii). By the construction of  $UUC$ ,  $\bar{x} \in UUC$  is not covered in  $UUC$ . Thus there is no  $y \in F(x_k) \setminus \{x_{k+1}\}$  such that  $\bar{x}_k \bar{y} \triangleright_k \bar{x}$ , for all  $\bar{y} \in UUC$  such that  $y_0 = y$ . ■

By Theorem 13 (i), since  $X$  is nonempty,  $UUC$  cannot be empty.

**Corollary 14**  *$UUC$  is nonempty.*

The next result shows that  $UUC$  is the (unique) maximal consistent collection of paths in the sense of set inclusion.

**Theorem 15**  *$UUC$  contains any consistent collection of paths.*

**Proof.** Let  $\bar{B}$  be a consistent collection of paths. Take any  $\bar{x} \in \bar{B}$ . Since  $\bar{x}$  satisfies part (ii) of the definition of consistent collection of paths, it follows by the definition of covering in  $\bar{X}$  that  $\bar{x} \in UC(\bar{X}) = UC^1$ . Since  $\bar{x}$  was arbitrary,  $\bar{B} \subseteq UC^1$ . By the definition of covering in  $UC(\bar{X})$ ,  $\bar{B} \in UC(UC^1) = UC^2$ . Again,  $\bar{B} \subseteq UC^2$ . By induction,  $\bar{B} \subseteq UC^T =: UUC$ . Since  $UUC$  is a consistent collection of paths, it is the maximal consistent collection of paths. ■

Collecting Theorems 6 and 13, we have characterized possible equilibrium play paths and outcome that are implementable with any equilibrium.

**Corollary 16** *A play path can be induced by a well defined strategy satisfying the one-deviation property if and only if it belongs to  $UUC$ . Moreover, the outcomes that are implementable via any such strategy are contained in  $\pi[UUC]$ .*

### 3.2 Algorithmic Considerations

The problem with the solution concepts is often their computability. Such questions are particularly acute here since the set of paths  $\bar{X}$  is typically infinite. A convenient algorithm for computing the relevant elements of the largest consistent collection of paths is now provided.

First we simplify the paths without losing any of their important properties. We say that  $\bar{y} = (y_0, \dots, y_L) \in \bar{X}$  is a *reduction* of  $\bar{x} = (x_0, \dots, x_K) \in \bar{X}$  if  $x_0 = y_0$ ,  $x_K = y_L$ , and  $\{y_l\} \subseteq \{x_k\}$ . Then  $\bar{y}$  is a *full reduction* of  $\bar{x}$  if it is a reduction of  $\bar{x}$  and the only reduction of  $\bar{y}$  is  $\bar{y}$  itself. That is,  $\bar{y}$  contains only those nodes of  $\bar{x}$  that are needed to travel from  $x_0$  to  $x_K$ . A full reduction of  $\bar{x}$  need not be unique.

For any set  $\bar{B}$  of paths, denote by  $(\bar{B})_{FR}$  the collection of all full reductions of the elements in  $\bar{B}$ . By the definition of reduction, if  $\bar{B}$  itself consists of fully reduced paths, then  $(\bar{B})_{FR} = \bar{B}$ .

Let  $UC_{FR}^0 = (\bar{X})_{FR}$  and identify  $UC_{FR}^j = UC(UC_{FR}^{j-1})$  for all  $j = 1, \dots$ . Denote the ultimate uncovered set of fully reduced paths by  $UUC_{FR} = UC_{FR}^\infty$ .

Since the length of a fully reduced path is at most  $|X|$ , the algorithm is computable in finite time (not necessarily in polynomial, though.)

Now we argue that the algorithm produces equilibrium strategy recommendations. Moreover, it characterizes all *simple* strategy recommendations.

**Proposition 17**  $(UUC)_{FR} = UUC_{FR} \subseteq UUC$ .

**Proof.** *Step 1:* Let  $t$  be the first stage when  $\bar{x} \in UC_{FR}^t \setminus UC^t$ . By assumption,  $UC_{FR}^{t-1} \subseteq UC^{t-1}$ . By the definition of covering, since  $x$  is covered in  $UC^{t-1}$  it must be covered in  $UC_{FR}^{t-1}$ , a contradiction. Thus  $UC_{FR}^t \subseteq UC^t$ , for all  $t$ .

*Step 2:* We now prove that  $UC_{FR}^t = (UC^t)_{FR}$  for all  $t$ . By Step 1,  $UC_{FR}^t = (UC_{FR}^t)_{FR} \subseteq (UC^t)_{FR}$  for all  $t$ . For other direction, let  $t$  be the first stage when  $\bar{x} \in (UC^t)_{FR} \setminus UC_{FR}^t$ . By assumption  $(UC^{t-1})_{FR} \subseteq UC_{FR}^{t-1}$ . By the definition of covering, since  $x$  is covered in  $UC_{FR}^{t-1}$  it must be covered in  $UC^{t-1}$ , a contradiction. Thus  $(UC^t)_{FR} \subseteq UC_{FR}^t$ , for all  $t$ .

*Step 3:* Combining steps 1 and 2, we have  $(UC^t)_{FR} = UC_{FR}^t \subseteq UC^t$  for all  $t$ . Thus also  $(UUC)_{FR} = UUC_{FR} \subseteq UUC$ . ■

Since, By Proposition 17,  $(UUC)_{FR} = UUC_{FR}$ , it follows that the outcomes that can be implemented with  $UUC$  coincide with the outcomes that can be implemented with  $UUC_{FR}$ .

**Proposition 18**  $\pi[UUC_{FR}] = \pi[UUC]$ .

Thus the algorithm provides an unbiased prediction of the outcomes that can be implemented in equilibrium of the original game.

## 4 Coalitional Interpretation

### 4.1 Relation to the Largest Consistent Set

The now we develop the solution concept succeeded by Chwe (1994). First, an outcome  $y$  *directly* dominates  $x$  if there is a coalition  $S$  such that  $y \in F_S(x)$  and  $y \succ_S x$ . An outcome  $y$  *indirectly* dominates  $x$  if there is a pair  $(\bar{x}, \bar{S})$  of paths of outcomes and coalitions such that  $\bar{x} = (x_0, x_1, \dots, x_K)$  and  $\bar{S} = (S_0, \dots, S_{K-1})$ , and such that  $x_0 = x$ ,  $y = x_K$ , and  $x_{k+1} \in F_{S_k}(x_k)$  from  $x$  to  $y$  such that  $x_K \succ_{S_k} x_k$ , for all  $k = 0, \dots, K - 1$ .

Set  $C \subseteq X$  is a *consistent set* if  $C$  consists of all  $x$  for which the following holds: if  $y \in F_S(x)$ , then there is  $z \in C$  that indirectly dominates  $y$  such that  $x \succ_i z$  for some  $i \in S$ . Chwe (1994) showed that a consistent set exists and the *largest* consistent set is unique.

Chwe's solution, even though one of the most used coalitional solutions, has been subject to criticism that the indirect dominance need not be credible: the path of blockings may be deviated by a subset of an active coalition. The following example is due to Xue (1998): (where  $x \xrightarrow{S} y$  reflects the relation  $y \in F_S(x)$ )

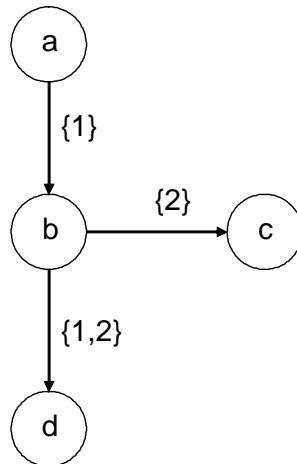

Figure 3

Consider the game in Figure 3, where  $N = \{1, 2\}$ ,  $X = \{a, b, c, d\}$ , and  $F_{\{1\}}(a) = \{a, b\}$ ,  $F_{\{2\}}(b) = \{b, c\}$ ,  $F_{\{1,2\}}(b) = \{b, d\}$ , and in all other cases  $F_S(x)$  is just a singleton. Recall that in our model  $x$  is implemented if  $x \in$

$F_{\{i\}}(x)$  is chosen. Numerical payoffs from each choice (in the order of their indices) are

$$\begin{aligned} a &: (6, 0), \\ b &: (7, 4), \\ c &: (5, 10), \\ d &: (10, 5). \end{aligned}$$

In the set up of Figure 3, the largest consistent set chooses  $\{a, c, d\}$ . However, the largest consistent set is too large since it is not reasonable to predict that  $d$  is ever chosen: when  $a$  is the status quo, the "predicted" outcomes are  $\{a, d\}$ , the latter in the case when coalition  $\{1, 2\}$  forms in status quo  $b$ . But note that once node  $b$  is reached and the coalition  $\{1, 2\}$  is about to form, player 2 would renege and choose the option  $c$  instead. Hence,  $d$  should not be considered as a conceivable outcome.

This example suggests that indirect dominance over outcomes does not suffice but rather, also dominance over paths must be taken under consideration. As in Section 3, define a dominance relation over paths of outcomes. Relative to that model, the only additional subtlety now concerns when to allow a coalition to activate if there already is an active coalition. We proceed as suggested by the example above, and allow coalition to interfere a path if it is allowed to move at the current node and if it is a subcoalition of the currently active coalition. This assumption is motivated by the idea that members of an active coalition need to communicate, and hence they can coordinate into a smaller different coalition. The question is of determining which coalition serves as a status quo coalition in nodes through which the play evolves. After this choice not all coalitions are in a symmetric position since, due to unmodeled coordinative activity between coalition members, they are not furnished with similar communication preparedness. The solution then asks which coalitional plays are consistent with the choice of active coalitions. In a simple recursive game this is not an issue since there is only one potential decision maker at a time.

**Proposition 19** *Let  $CCP$  be a consistent collection of paths. Then  $\pi[CCP]$  is a consistent set.*

**Proof.** Suppose, on the contrary, that  $\pi[CCP]$  is not a consistent set. Then there is an  $x \in \pi[CCP]$ , an  $S$ , and a  $y \in F_S(x)$  such that  $\pi[\bar{y}] \succ_S x$ , for all  $\bar{y} \in CCP$  such that  $y_0 = y$ . But this contradicts the assumption that there is  $\bar{z} \in UUC$  such that  $\pi(\bar{z}) = x$  and that  $UUC = UC(UUC)$ . ■

However,  $\pi[UUC]$  is not the largest consistent set: it is a refinement of the largest consistent set. One example is the game in Figure 3:  $UUC$  consists of  $\{(a), ((b, c), \{2\}), (c), (d)\}$ , thus if  $a$  is the status quo, then  $a$  is implemented, if  $b$  is the status quo, then  $c$  is implemented, and if  $c$  (or  $d$ ) is the status quo, then  $c$  (or  $d$ ) is implemented.

The following example is more dramatic.

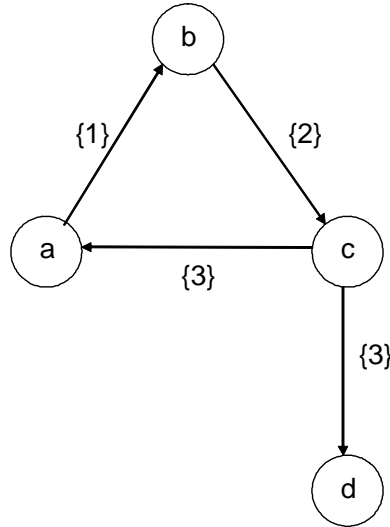

Figure 4

Here  $N = \{1, 2, 3\}$ ,  $X = \{a, b, c, d\}$ , and  $F_{\{1\}}(a) = \{a, b\}$ ,  $F_{\{2\}}(b) = \{b, c\}$ ,  $F_{\{3\}}(c) = \{a, c, d\}$ . Numerical payoffs from each choice are

$$\begin{aligned}
 a &: (0, 0, 1), \\
 b &: (0, 1, 0), \\
 c &: (1, 0, 0), \\
 d &: (2, 2, 2).
 \end{aligned}$$

The largest consistent set is  $\{a, b, d\}$ . However, the largest consistent collection of paths  $UUC$  consists only of the path  $(a, b, c, d)$  and hence  $\pi[UUC] = \{d\}$ .

## 4.2 Path Stability

Xue (1998) is based on the same idea as this paper; that what is crucial is the stability of paths rather than outcomes. He uses von Neumann-Morgenstern stable set approach to identify paths that are robust against deviations. In the analysis that proceeds, perfect foresight is captured explicitly by the

"situation with perfect foresight":<sup>4</sup> Assume that alternative  $a \in X$  is the status quo. Consider a path  $\bar{x}$  and some of its node  $x_k$ . Assume that a coalition  $S$  can replace  $x_k$  by some alternative  $y \neq x_{k+1}$ . In doing so,  $S$  is aware of that the set of feasible paths from  $y$  is  $\bar{X}_y := \{\bar{y} \in \bar{X} : y_0 = y\}$ . In contemplating such a deviation from  $y$ , however, members of  $S$  base their decision on comparing paths that might be followed by rational and farsighted individuals at  $y$ . Let  $SB(y) \subset \bar{X}_y$  denote this *standard of behavior*.

The following definition describes a conservative approach to stable standard of behavior.

**Definition 20** *An SB is conservatively stable if it is*

- (1) *internally stable: for all  $x \in X$ , if  $\bar{x} \in SB(x)$ , then there is no  $y, k$ , and  $S$  such that  $x_{k+1} \neq y$ ,  $y \in F_S(x_k)$ , and  $\pi[\bar{y}] \succ_S \pi[\bar{x}]$ , for all  $\bar{y} \in SB(y)$ ,*
- (2) *externally stable: for all  $x \in X$ , if  $\bar{x} \in \bar{X}_x \setminus SB(x)$ , then there is  $y, k$ , and  $S$  such that  $y \in F_S(x_k)$ ,  $x_{k+1} \neq y$ , and  $\pi[\bar{y}] \succ_S \pi[\bar{x}]$ , for all  $\bar{y} \in SB(y)$ .*

To see most clearly the relationship between our solution concept and the conservatively stable standard of behavior, let us rewrite the definition of a consistent collection of paths in the form, that is equivalent to the original definition:

**Definition 21 (Consistent collection of paths II)** *A coalitional consistent collection of paths CCP satisfies*

- (1) *internal stability: if  $\bar{x} \in CCP$ , then there is no  $y$  and  $k$  such that  $x_{k+1} \neq y$ , and such that  $x_{k+1} \in F_{S'}(x_k)$  implies  $y \in F_S(x_k)$  and  $\pi[\bar{y}] \succ_S \pi[\bar{x}]$  for all  $\bar{y} \in \bar{X}_y \cap CCP$ , for some  $S \subseteq S'$ ,*
- (2) *external stability: if  $\bar{x} \in \bar{X} \setminus CCP$ , then there is  $y$  and  $k$  such that  $x_{k+1} \neq y$ , and such that  $x_{k+1} \in F_{S'}(x_k)$  implies  $y \in F_S(x_k)$  and  $\pi[\bar{y}] \succ_S \pi[\bar{x}]$  for all  $\bar{y} \in \bar{X}_y \cap CCP$ , for some  $S \subseteq S'$ .*

From this definition it is clear that the key difference between the solution concepts is that a *CCP* requires that the deviant coalition must be a subcoalition of an active coalition. This requirement prevents pathological

---

<sup>4</sup>Referring to Greenberg's (1991) Theory of Social Situations.

blocking relationships, exemplified in the following case (due to Xue, 1998):

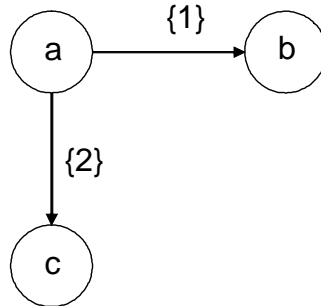

Figure 5

where payoffs are

$$\begin{aligned} a & : (0, 0), \\ b & : (2, 1), \\ c & : (1, 2). \end{aligned}$$

The unique conservative standard of behavior is empty, and hence gives no guidance how the play evolves. However, there are two *CCPs*:  $\{(a, b), b, c\}$  and  $\{(a, c), b, c\}$ .

### 4.3 Blocking in Real Time

In this section we interpret our results in the framework of dynamic coalition formation by Konishi and Ray (2003).<sup>5</sup> A model is captured by a tuple  $\langle N, Z, u, (F_S)_{S \in 2^N}, \delta \rangle$  where  $X$  is now interpreted as a set of *states* and  $N$  the set of players,  $u_i(x)$  as the utility of player  $i$  in state  $x$ , and  $F_S(x) \subseteq X$  such that  $x \in F_S(x)$  is the set of states achievable by a one-step coalitional move by a coalition  $S$  from  $x$ , for all  $x \in X$ , and for all  $S \in 2^N$ .

Parameter  $\delta \in (0, 1)$  is a discount factor, and player  $i$ 's payoff from a sequence of states  $\bar{x} = x_0, \dots, x_t$  may be written as  $\sum_{\tau=0}^t \delta^\tau u_i(x^\tau)$ . Let  $H$  be the set of all histories of states  $(x_0, \dots, x_t)$  such that  $x_0 = x^*$ . A deterministic *process of coalition formation* (PCF) is now a function  $g : H \rightarrow X$ , capturing the transitions from one history to another. These transitions will be induced by coalitions who stand to benefit from them. A PCF  $g$  induces a value function  $v_i$  for each  $i \in N$ . This value function captures the infinite horizon payoff to a player starting from any state history  $(h, x)$  under the Markov

<sup>5</sup>For a similarly oriented approach, see Gomez and Jehiel (2005).



process  $g$ . By the standard observation, the value function for  $i$  is the unique solution to the functional equation

$$v_i(h, x) = (1 - \delta)[u_i(x) + \delta v_i(h, x, g(h, x))].$$

Let  $g^0(h) = g(h)$  and  $g^t(h) = g(h, g^t(h))$ , for all  $t = 1, \dots$ . We focus on PCFs that are *absorbing*: starting from any history  $h$  there is  $t_h$  and state  $x$  such that for all  $t \geq t_h$ ,

$$g^t(h) = x.$$

That is, starting from any history, the strategy does not cycle in the long run: it converges to some state and stays there. Absorbing PCFs have the great benefit that one can approximate the long term payoffs of the players by their direct, short term payoffs.

We are now in a position to define profitable moves. A move  $y \in F_S(x)$  is efficient for  $S$  if there is no  $z \in F_S(x)$  such that  $v_S(h, z) > v_S(h, y)$ . Following Konishi and Ray (2003), define a deterministic *equilibrium process of coalition formation* (EPCF) as follows: (i) if  $g(h, x) = y \neq x$ , then there is  $S$  such that  $y \in F_S(x)$  and

$$v_S(h, x, y) \geq v_S(h, x, x).$$

(ii) if there is a  $z$  and an  $S$  such that  $z \in F_S(x)$  and

$$v_S(h, x, z) > v_S(h, x, y),$$

then  $g(h, x) = y \neq x$  is efficient for  $S'$  such that

$$v_{S'}(h, x, z) > v_{S'}(h, x, x).$$

Konishi and Ray (2003) showed the existence of a random, stationary EPCF. Here we argue that there is also deterministic EPCF if one drops stationarity assumption, i.e. allows  $g$  to be dependent on the history  $h$ , and not only on the current state  $x$  as the stationary PCF does.

Denote by

$$\bar{g}(h) = (g^0(h), \dots, g^{t_h}(h))$$

the paths of states that will materialize according to PCF  $g$  starting from history  $h$ , and by

$$\bar{g}(H) = \{\bar{x} : \bar{g}(h) = \bar{x}, \text{ for some } h \in H\}$$

**Proposition 22** *There is  $\delta^*$  such that if  $\delta > \delta^*$ , then, for any CCP, there is a deterministic and absorbing EPCF  $g$  such that  $\bar{g}(H) = CCP$ .*

**Proof.** Fix  $CCP$  and construct  $g$  from it by letting  $g^t(x_0, \dots, x_{k-1}, x_k) = x_k$  if  $x_{k-1} = x_k$ , for all  $t = 0, 1, \dots$ , and if  $y \neq x_{k+1}$  such that  $\bar{x} = (x_0, \dots, x_K) \in CCP$ , then  $g^t(x_0, \dots, x_k, y) = y_t$ , for all  $t = 1, \dots, L$ , such that  $u_i(y_L) \leq u_i(x_K)$  for some  $i \in S$  such that  $y \in F_S(x_k)$ . We need to show that such  $g$  is consistent with (i) and (ii) of EPCF.

Suppose, on the contrary, that  $g$  violates (i) under  $\bar{x} \in CCP$ . Then there is  $x_{k+1} \neq x_k$  such that  $x_{k+1} \in F_S(x_k)$  and

$$v_i(h, x_k, x_{k+1}) < v_i(h, x_k, x_k), \text{ for some } i \in S. \quad (8)$$

But since  $v_i(h, x_k, x_k) = (1 - \delta)[u_i(x_k) + \delta u_i(x_k) + \delta^2 u_i(x_k) + \dots] = u_i(x_k)$ . By continuity,  $v_i(h, x_k, x_{k+1}) \approx u_i(x_k)$ . But then (8) conflicts (??).

Suppose that  $g$  violates (i) under  $\bar{x} \in CCP$ . Since, by continuity,  $v_i(h, x_k, y) \approx u_i(y_L)$  such that  $u_i(y_L) \leq u_i(x_K)$  for some  $i \in S' \subseteq S$  such that  $y \in F_S(x_k)$  and  $x_{k+1} \in F_S(x_k)$ , it follows that  $x_{k+1}$  is efficient for  $S$ . ■

## 5 Efficiency

The classic question in coalitional analysis concerns efficiency. An argument that goes under the label of Coase theorem says that an outcome that results from unrestricted coalitional bargaining will always be efficient: otherwise a coalition would block the outcome by proposing another outcome that all the players prefer. This intuition is not insufficient in the current framework.

Consider a game in Figure 6. The payoffs to three players  $N = \{1, 2, 3\}$  as depicted in different nodes. Each shaded node is Pareto dominated by some other node, reflected by the arrow from the node to another node. At each node all subcoalitions are entitled to move the game to any node. Thus there are no *a priori* restrictions on what the coalitions can achieve. Nevertheless there is a  $CCP$  such that  $\pi[CCP]$  consists only of the shaded nodes  $(2, 0, 1)$ ,  $(1, 2, 0)$ , or  $(0, 1, 2)$ . The construction is as follows: if, say,  $(2, 0, 1)$  is blocked by  $N$  to  $(3, 1, 2)$ , then  $(3, 1, 2)$  is blocked by  $\{2\}$  to  $(1, 2, 0)$ , which remains unblocked and becomes implemented. A similar consideration

applies to blocking from  $(1, 2, 0)$  or  $(0, 1, 2)$ .

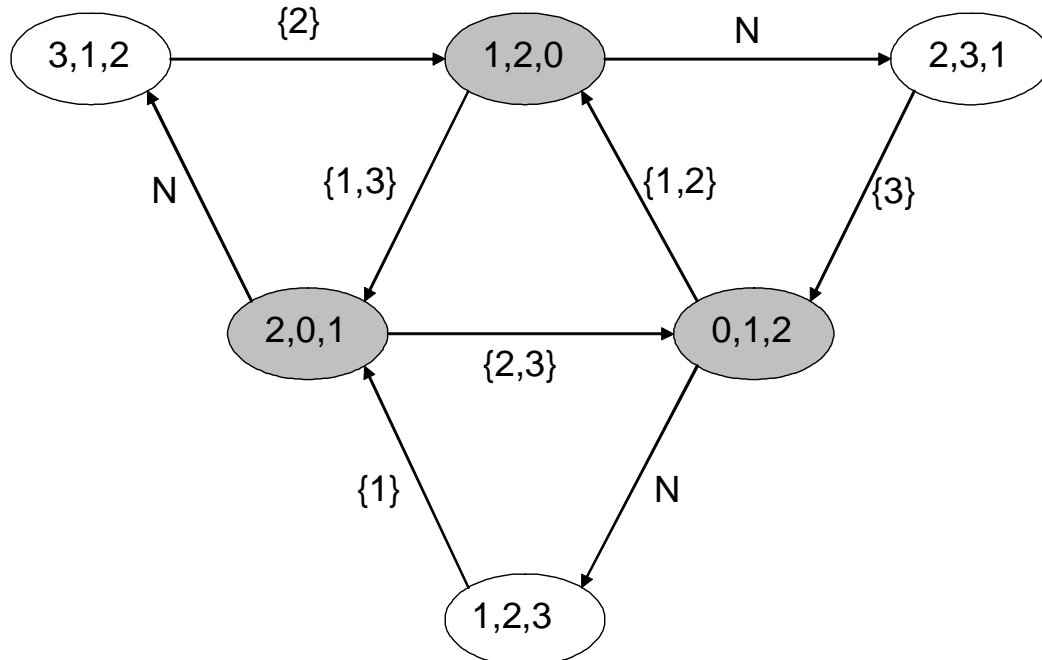

Figure 6

Thus there is nothing inconsistent with the idea that an inefficient outcome becomes implemented, even if bargaining opportunities are unrestricted.

## References

- [1] Aumann, R. and M. Maschler (1964), The Bargaining Set for Cooperative Games, in *Advances in Game Theory*, (M. Dresher, L.S. Shapley, and A.W. Tucker, Eds.), Princeton University Press, Princeton, NJ,
- [2] Barberà, S. and A. Gerber (2007), A note on the impossibility of a satisfactory concept of stability for coalition formation games, *Economics Letters* 95, 85-90
- [3] Chwe, M. (1994), Farsighted stability, *Journal of Economic Theory* 63, 299-325
- [4] Diamantoudi, E. and L. Xue (2006), Coalitions, agreements and efficiency, forthcoming in *Journal of Economic Theory*
- [5] Dutta, B., D. Ray, K. Sengupta, and R. Vohra (1989), A Consistent Bargaining Set, *Journal of Economic Theory* 49, 93-112.

- [6] Dutta. B (1988), Covering sets and new condorcet correspondence, *Journal of Economic Theory* 44, 63-80
- [7] Greenberg, J.(1990), *The Theory of Social Situations*, Cambridge University Press, Cambridge
- [8] Fishburn, P. (1977), Condorcet social choice function, *SIAM Journal of Applied Math* 33, 295-306
- [9] Gomez, A. and P. Jehiel (2005). Dynamic Process of Social and Economic Interactions: On the Persistence of Inefficiencies, *Journal of Political Economy* 113, 626-67
- [10] Herings, J.-J., Mauleon, A and V. Vannetelbosch (2004), Rationalizability for social environments, *Games and Economic Behavior* 49: 1, 135-56
- [11] Harsanyi, J. (1974), An equilibrium point interpretation of stable sets and a proposed alternative definition, *Management Science* 20, 1427-9.
- [12] Konishi, H. and D. Ray (2003), Coalition formation as a dynamic process, *Journal of Economic Theory* 110, 1-41
- [13] Miller, N. (1980), A new solution set to for tournaments and majority voting, *American Journal of Political Science* 24, 68-96
- [14] Page, F., Kamut, S. and M. Wooders (2005), Networks and Farsighted Stability, *Journal of Economic Theory* 120, 257-61
- [15] Ray, D. (2007), *A game theoretic perspective on coalition formation*, Oxford University Press, Oxford, UK
- [16] Xue, L. (1997), Nonemptiness of the Largest Consistent set , *Journal of Economic Theory*
- [17] Xue, L (1998), Coalitional stability under perfect foresight, *Economic Theory* 11, 603-27
- [18] Vartiainen, H. (2005), Cognitive equilibrium, manuscript, ACE Working Paper 20
- [19] von Neumann, J. and O. Morgenstern (1947), *Theory of Games and Economic Behavior*, Princeton University Press, Princeton, NJ

**Aboa Centre for Economics (ACE)** was founded in 1998 by the departments of economics at the Turku School of Economics, Åbo Akademi University and University of Turku. The aim of the Centre is to coordinate research and education related to economics in the three universities.

Contact information: Aboa Centre for Economics, Turku School of Economics, Rehtorinpellonkatu 3, 20500 Turku, Finland.

**Aboa Centre for Economics (ACE)** on Turun kolmen yliopiston vuonna 1998 perustama yhteistyöelin. Sen osapuolet ovat Turun kauppakorkeakoulun kansantaloustieteen oppiaine, Åbo Akademin nationalekonomi-oppiaine ja Turun yliopiston taloustieteen laitos. ACEn toiminta-ajatuksena on koordinoida kansantaloustieteen tutkimusta ja opetusta Turun kolmessa yliopistossa.

Yhteystiedot: Aboa Centre for Economics, Kansantaloustiede, Turun kauppakorkeakoulu, 20500 Turku.

[www.ace-economics.fi](http://www.ace-economics.fi)

ISSN 1796-3133