

Kirstein, Roland

Working Paper

Bayesian Monitoring.

CSLE Discussion Paper, No. 2005-06

Provided in Cooperation with:

Saarland University, CSLE - Center for the Study of Law and Economics

Suggested Citation: Kirstein, Roland (2005) : Bayesian Monitoring., CSLE Discussion Paper, No. 2005-06, Universität des Saarlandes, Center for the Study of Law and Economics (CSLE), Saarbrücken

This Version is available at:

<https://hdl.handle.net/10419/23077>

Standard-Nutzungsbedingungen:

Die Dokumente auf EconStor dürfen zu eigenen wissenschaftlichen Zwecken und zum Privatgebrauch gespeichert und kopiert werden.

Sie dürfen die Dokumente nicht für öffentliche oder kommerzielle Zwecke vervielfältigen, öffentlich ausstellen, öffentlich zugänglich machen, vertreiben oder anderweitig nutzen.

Sofern die Verfasser die Dokumente unter Open-Content-Lizenzen (insbesondere CC-Lizenzen) zur Verfügung gestellt haben sollten, gelten abweichend von diesen Nutzungsbedingungen die in der dort genannten Lizenz gewährten Nutzungsrechte.

Terms of use:

Documents in EconStor may be saved and copied for your personal and scholarly purposes.

You are not to copy documents for public or commercial purposes, to exhibit the documents publicly, to make them publicly available on the internet, or to distribute or otherwise use the documents in public.

If the documents have been made available under an Open Content Licence (especially Creative Commons Licences), you may exercise further usage rights as specified in the indicated licence.

Bayesian Monitoring.

Roland Kirstein*

Center for the Study of Law and Economics
Discussion Paper 2005-06, August 2005

Abstract

This paper presents a modification of the inspection game: The “Bayesian Monitoring” model rests on the assumption that judges are interested in enforcing compliant behavior and making correct decisions. They may base their judgements on an informative but imperfect signal which can be generated costlessly. In the original inspection game, monitoring is costly and generates a perfectly informative signal.

While the inspection game has only one mixed strategy equilibrium, three Perfect Bayesian Equilibria exist in my model (one in pure strategies, two in mixed). These outcomes can be described with respect to their punishment styles: tyrannic, draconian, and lenient.

The Bayesian Monitoring model, just as the inspection game, has different implications than enforcement models in the tradition of Becker (1968). Total deterrence of bad behavior is impossible, and the equilibrium probability of good behavior is independent of the suspect’s own payoff parameters. Hence, the maximum fine result does not apply.

JEL classification: K 40, C 72, D 81

Keywords: Imperfect Decision-Making, Perfect Bayesian Equilibrium, Enforcement, Maximum Fine Result

*Center for the Study of Law and Economics (CSLE), University of Saarland, D-66041 Saarbrücken, Germany; (email: rol@mx.uni-saarland.de). This paper was finished while I enjoyed the hospitality of the Economics Department at the University of California in Santa Barbara, CA. I am grateful to Max Albert, Ted Frech III., Thomas Kallenbrunnen, Rosemarie Lavaty, Dieter Schmidtchen, and Birgit Will for their helpful comments.

1 Introduction

This paper analyzes the enforcement of “good” behavior by benevolent but imperfect decision-making judges. “Bad” behavior is defined as causing a negative externality which exceeds the benefit internalized by the offender; it therefore implies a welfare loss. Thus, good behavior is efficient. Judicial benevolence is characterized by two assumptions. First, judges prefer higher social welfare. Hence, they are interested in avoiding welfare losses and encouraging good behavior. Second, judges prefer correct judgements over incorrect ones.¹ The first assumption would be justified when the compensation of judges is linked to the social product. The second assumption reflects a preference for justice.²

Another property that characterizes judges in this paper is imperfect decision-making.³ I assume that judges are not perfectly informed about the actual behavior of the suspect, although they are not blind. Through examination of a case, an experienced judge is able to generate an informative signal which is correlated with what the suspect has actually done.⁴ I assume this signal to be costless. A judge might commit two types of errors, namely incorrect convictions as well as incorrect acquittals.⁵ The error probabilities provide a measure for the judge’s monitoring skill. The enforcement system set up in this paper reflects an almost ideal world.⁶ Judicial errors are caused by information problems, not by incompatible incentives. The potential problem of how judicial incentives can be aligned with the preferences of society is assumed to be solved.⁷ This ideal world, however, is not unrealistic, but close to the actual situation of judges.

¹Posner (1994, 23f.) argues that judicial decisions may, among other factors, be governed by intrinsic motivation. Also see Macey (1994) and Alexander (1994).

²See Feddersen/Pesendorfer (1998, 24) who assume a negative judicial payoff for wrong decisions.

³See Kirstein/Schmidtchen (1997).

⁴The ability to base a judgement on an informative signal can also be interpreted as judicial competence; see Hadfield (1994).

⁵See Tullock (1980), (1994), Kirstein/Schmidtchen (1997), or Jost (1997).

⁶With zero monitoring costs, the model is even closer to an ideal world than the one in Usman (2002). Introducing costs would complicate the equilibrium analysis without altering the results, as long as the costs are moderate.

⁷For the analysis of judicial incentives see, e.g., Posner (1994) or Anderson/Shugart/Tollison (1989).

In the inspection game, a benevolent judge can perfectly observe the suspect's behavior, but monitoring is costly. Assume that a monitor may choose to inspect or not, and a suspect may choose between good and bad behavior. The monitor prefers to inspect if he expects the suspect to behave badly. If, however, the monitor expects the suspect to choose good behavior, he prefers to save the inspection costs. Assume furthermore that the suspect prefers good behavior when inspected, and bad behavior when the monitor abstains from inspection. Then, the simultaneous one-shot game has no Nash equilibrium in pure strategies.⁸ Perfect deterrence, therefore, can never be part of a Nash equilibrium.

In section 2, I set up the Bayesian monitoring model. It reflects the fact that the interaction between the monitor and the suspect often has a sequential nature, even if the action of the latter cannot be perfectly observed by the former. The inspection game as well as models in the tradition of Becker (1968) abstract from this fact.⁹

In section 3, I will derive the three Perfect Bayesian Equilibria. In none of these equilibria is the suspect motivated to choose good behavior with certainty. The intuition for this result is that a rational judge would not base his decision on an imperfect signal if he believed the suspect to have chosen good behavior. Bayesian updating should induce the judge to acquit the suspect, even if the signal says otherwise. However, the suspect's best reply to a sure acquittal would be to commit bad behavior. As in the inspection game, the judge is unable to induce the suspect to choose good behavior with probability one, even though it is assumed that his incentives are perfectly aligned and the monitoring signal is costless.

⁸See Wittman (1985) or Tsebelis (1989), (1990a), (1990 b). Holler (1990) has questioned the usage of mixed strategies as the solution concept and proposed Maximin strategies as more profitable for the players. Wittman (1993), however, has argued that Maximin strategies do not constitute a Nash equilibrium and therefore lack stability.

⁹See Polinsky/Shavell (2000) for a survey of the traditional enforcement model. The Becker approach focuses in a price-theoretical manner on the decision-making of the potential offender, taking the parameters of the enforcement system as exogenous. This approach disregards the strategic interaction between potential offender and a rational enforcer who would update his beliefs in a Bayesian way. The literature on contract theory acknowledges the problem of rational updates of monitoring agents. See, e.g., Baiman/May/Mukherji (1990), Cheng (1990), Mirrlees (1999), Faure-Grimaud/Laffont/Martimort (2003).

The monitoring problem has been discussed in an informal manner by Ed Schwartz (1995) and Steven Shavell (1995, 1996) with respect to appeals courts. Schwartz has pointed out that the analysis of appeals courts in Shavell (1995) is based on the assumption that the judges do not draw Bayesian inferences from the fact that an appeal has been brought. If judges are modeled as strategic actors, however, then a separating result (according to which only legitimate appeals are brought), cannot be part of an equilibrium.

The reply of Shavell (1996) mixes up normative and positive analysis: as a Bayesian update would lead to undesirable results, it is not desirable that judges use it.¹⁰ To sustain his view, Shavell points out that judges have to base their decision on written opinions, and Bayesian inference would be unacceptable as a written opinion. However, the verbal representation of the results of judicial reasoning does not necessarily have to reflect the line of reasoning. Decision theory predicts that rational judges use Bayesian inference when making their decisions; an experienced judge will certainly be able to find an acceptable wording for any opinion he has formed this way. Certainly, no judge will come to a decision only after he has written down the reasons for it.¹¹

My model differs from the one in Reinganum/Wilde (1986), which is a signaling game and not a monitoring game. In their model, the suspect knows his type and chooses a report which is sent to the enforcement authority. In a separating equilibrium, the authority can infer the suspect's type from the report. Both the signaling model and the inspection model address the enforcer's commitment problem. If an enforcer is unable to commit to a specific monitoring strategy, then perfect enforcement cannot be part of an equilibrium as the enforcer always has an incentive not to monitor when he expects the suspect to comply with certainty.¹² The traditional enforcement theory assumes that commitment to a specific enforcement probability is possible.¹³

¹⁰In his earlier article, Shavell has already stressed this point: "...such information should not be considered in judging...", see Shavell (1995, 363).

¹¹Modern literature on auditing takes it as self-evident that regulators are not committed to a specific reaction to the signals they receive; see, e.g., Khalil (1997, 639) or Baliga/Corchon/Sjöström (1997).

¹²Also see Khalil/Lawarrée (1995, 443).

¹³See, among the many contributions to this literature, Becker (1968) or Reinganum/Wilde (1985); also see Graetz/Reinganum/Wilde (1985). This assumption has been challenged by

Another model which is different from the one presented here is analyzed in Berentsen/Brügger/Lörtschler (2003). They start with an interaction between two suspects. The result of this interaction provides a signal to a monitor who then decides whether to monitor or not. Their model acknowledges the existence of monitoring costs but assumes the monitor's signal to be perfect. Thus, judicial detection skills represented by the quality of the monitoring signal are left out of focus. These parameters play a central role in my model.

Of the three Perfect Bayesian Equilibria derived in section 3, one is an equilibrium in pure strategies. The existence of a pure strategy equilibrium is a crucial difference from the inspection game. If the judge punishes regardless of the signal, then the suspect's best reply is to commit bad behavior. The other two equilibria involve mixed strategies. In one of these equilibria, the judge punishes with certainty when he receives the bad signal, and with positive probability if the signal indicates good behavior. Such a "draconic" judicial strategy results in a low likelihood of good behavior on the suspect's side. In the other mixed strategy equilibrium, the judge does not punish after receiving the good signal, but does punish with positive probability if the signal is bad. This "lenient" judicial strategy induces the suspect to choose good behavior with a higher probability than under the draconic strategy.

Comparative statics analysis demonstrates that the suspect's equilibrium probability of choosing good or bad behavior is independent of his own payoff parameters. The size of the sanction and the suspect's benefit from a transgression only influence the strategy choice of the monitor. This is in line with the results of the standard inspection game.¹⁴

Baker/Miceli (2005) who find that apprehension rates are lower if the enforcer can commit to a punishment strategy and only uses fines. Commitment, however, may be lead to higher apprehension rates if both fines and jail are used.

¹⁴Wittman (1985) and Bianco/Ordeshook/Tsebelis (1990). Also see Andreozzi (2004) for a surprising related result.

2 The Model

Two risk-neutral and rational players, a suspect (S) and a judge (J), play a one-shot game. It starts with the suspect's decision between good and bad behavior. Denote her decision as $d = g$ (for good) or $d = b$ (for bad). It is convenient to define the behavioral strategy $\gamma = \Pr(d = g)$. Assume that bad behavior incurs an internalized benefit, denoted as $B > 0$, and a negative externality $X > B$, while the cost and benefit of good behavior are normalized to zero. Let $W > 0$ represent the initial wealth of the suspect.¹⁵ When the suspect has made her choice, nature produces an informative signal, denoted as i . The signal may assume one out of two realizations, $i = g$ or $i = b$. The probability of receiving a particular signal realization is contingent on the suspect's choice: $r = \Pr(i = g|d = g), w = \Pr(i = g|d = b)$ with $1 \geq r > w \geq 0$.¹⁶ The parameters r and w provide a measure for the judge's monitoring skill: with $r = 1$ and $w = 0$, he monitors perfectly, with $r = w$, he has zero monitoring skill, and the intermediate case $0 < w < r < 1$ reflects imperfect, but positive monitoring skill.

The judge is unable to observe the suspect's actual choice. He only observes the signal and updates his beliefs using Bayes' rule. Denote his ex-post beliefs as $\mu = \Pr(d = g|i = g), \nu = \Pr(d = g|i = b)$. The judge then has to decide between a sanction ($j = s$) or an acquittal ($j = a$). I define the judge's behavioral strategies $\alpha = \Pr(j = s|i = g), \beta = \Pr(j = s|i = b)$.

Punishment imposes a burden on the suspect, denoted as P , with $0 < P < W$, but no benefit to the judge. But the judge is assumed to be benevolent, i.e., he has an interest in sanctioning correctly. This is represented by his payoff parameters $G > 0$ and $L > 0$. G reflects the judge's interest in a correctly issued sanction, i.e., if the suspect has indeed chosen bad behavior. On the other hand, $-L$ is the judicial loss from issuing an incorrect sanction (if the suspect's behavior actually was good). These payoffs are revealed only after

¹⁵The initial wealth plays no role in the subsequent equilibrium analysis, but eliminates the judgement proof problem.

¹⁶The parameter configuration $r \leq w$ would also reflect a correlation between the signal realization and the suspect's choice. This symmetric case can, therefore, be excluded from consideration. The cases $r = w$ and $r = 1, w = 0$ will be dealt with later.

the judicial decision has taken place. I assume sanctions to be inefficient, i.e., $P > G$: the judge's benefit from a justified sanction is smaller than the burden imposed on the suspect.

Figure 1: Bayesian Monitoring Game

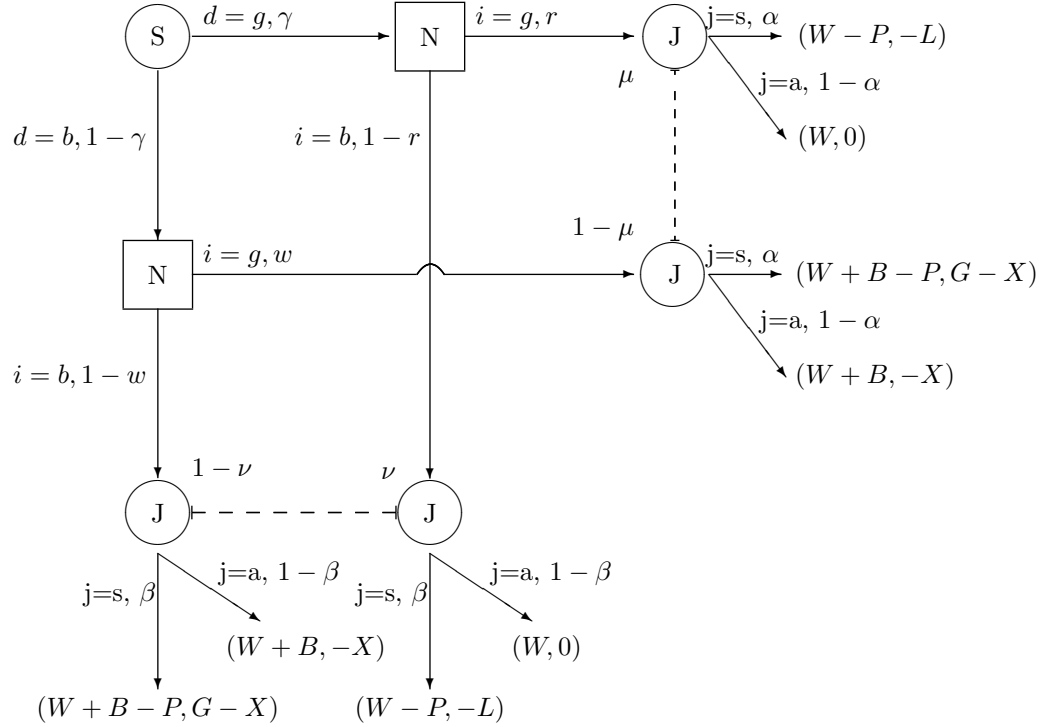

Figure 1 displays the interaction of the two players and the signals generated in the Bayesian Monitoring Game. Both players are assumed to be risk-neutral. The payoff parameters (W, P, B, X, G, L) and the signal quality parameters (r, w) are exogenously given and are common knowledge. Thus, the endogenous variables are $\alpha, \beta, \gamma, \mu$, and ν .

3 Equilibrium Analysis

In this section, the Bayesian Nash equilibria $\{(\alpha^*, \beta^*); (\mu^*, \nu^*); \gamma^*\}$ will be derived. α^*, β^* and γ^* denote the judge's and the suspect's behavioral strategies in equilibrium, respectively, while μ^* and ν^* denote the judge's equilibrium beliefs.

3.1 The Suspect's Optimal Choice

The suspect chooses her behavioral strategy γ so as to maximize her expected payoff, given the behavioral strategies (α, β) which she expects her opponent to play. Thus, an equilibrium value γ^* is determined by

$$\gamma^* = \arg \max \{W - \gamma[r\alpha + (1-r)\beta]P + (1-\gamma)B - (1-\gamma)[w\alpha + (1-w)\beta]P\}.$$

The first derivative with respect to γ is: $-P[r\alpha + (1-r)\beta] - B + P[w\alpha + (1-w)\beta]$. This expression can be rearranged to $P(r-w)(\beta - \alpha) - B$, which allows me to write the suspect's reaction function $\gamma^*(\alpha, \beta)$ as

$$\begin{aligned} \gamma^* = 1 &\Leftrightarrow \beta - \alpha > K \\ 0 < \gamma^* < 1 &\Leftrightarrow \beta - \alpha = K \\ \gamma^* = 0 &\Leftrightarrow \beta - \alpha < K \end{aligned}$$

with $K = \frac{B}{(r-w)P}$.¹⁷ If $\gamma^* = 0$ or $\gamma^* = 1$, then the suspect chooses a pure strategy, while $0 < \gamma^* < 1$ represents the choice of a mixed strategy. Figure 2 illustrates the suspect's reaction function $\gamma^* = \gamma^*(\alpha, \beta)$. The bold pentagon in the lower left corner of the figure includes the (α, β) combinations to which the suspect's optimal reaction is $\gamma = 0$. The bold triangle in the upper right corner is situated above the (α, β) combinations which induce the suspect to choose $\gamma = 1$. Finally, the bold square in the center of the figure describes the (α, β) combinations that keep the suspect indifferent between all of his mixed strategies.

¹⁷Division by $(r-w)$ is possible as $r = w$ is excluded.

Figure 2: The Suspect's Reaction Function

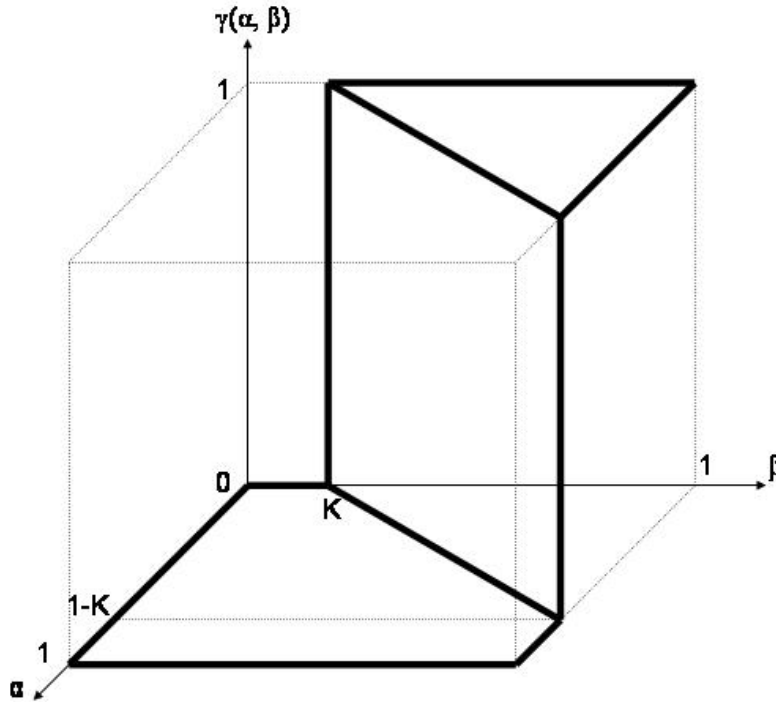

3.2 The Judge's Optimal Choice

A rational judge chooses his action given his anticipation of the behavioral strategy chosen by the suspect. From a strategic point of view, the game is simultaneous. However, the judge observes an imperfect signal triggered by the suspect's actual behavior. Therefore, his choice can be made contingent on the realization of this signal.

First, I examine the judge's optimal choice after having observed the signal realization $i = g$. In this case, Bayesian updating renders the following ex-post belief:

$$\mu = \frac{r\gamma}{r\gamma + w(1-\gamma)} \quad (1)$$

Taking these ex-post beliefs into account, the judge chooses the his behavioral strategy α^* so as to maximize $[(1 - \mu)(\alpha G - X) - \mu\alpha L]$. The first derivative with respect to α is $G - \mu(G + L)$.¹⁸ The relation between the optimal α and the suspect's strategy choice γ becomes clear if equation (1) is used to substitute for μ . Then, the first derivative can be rewritten as

$$G - \frac{r\gamma}{r\gamma + w(1 - \gamma)}(G + L).$$

This is negative if, and only if,¹⁹

$$\gamma > \frac{wG}{rL + wG}.$$

For simplicity, denote the right hand side of this inequality as γ_1 . The relation between the suspect's choice γ and the judicial behavioral strategy after having observed $i = g$ is summarized in the following reaction function $\alpha^* = \alpha^*(\gamma)$:

$$\begin{aligned} \alpha^* &= 1 \Leftrightarrow \gamma < \gamma_1 \\ 0 < \alpha^* < 1 &\Leftrightarrow \gamma = \gamma_1 \\ \alpha^* &= 0 \Leftrightarrow \gamma > \gamma_1 \end{aligned}$$

given $w > 0$. If $w = 0$, the first derivative is negative and, thus, the judge chooses $\alpha^* = 0$. He would never observe the good signal incorrectly and, thus, never react with a sanction.

In the same vein, the optimal behavioral strategy $\beta^*(\gamma)$ can be derived for the case in which the judge observes the signal realization $i = b$. Bayesian updating induces the ex-post belief

$$\nu = \frac{(1 - r)\gamma}{(1 - r)\gamma + (1 - w)(1 - \gamma)}.$$

and the judge chooses β so as to maximize $[(1 - \nu)(\beta G - X) - \nu\beta L]$. The first derivative with respect to β is $G - \nu(G + L)$. Substitution of ν allows to

¹⁸An interesting by-product of the analysis is that the negative externality X caused by the suspect's behavior is irrelevant for the judge's decision of whether to issue a sanction or not. If the suspect has chosen bad behavior, X is sunk. From then on, only G and L and the judge's beliefs determine whether he chooses to punish or not.

¹⁹The next inequality is equivalent to the "reliability condition" in Heiner (1983), (1986). See also Swets (1988), (1996).

state the reaction function $\beta^* = \beta^*(\gamma)$ as

$$\begin{aligned}\beta^* &= 1 \Leftrightarrow \gamma < \gamma_2 \\ 0 < \beta^* < 1 &\Leftrightarrow \gamma = \gamma_2 \\ \beta^* &= 0 \Leftrightarrow \gamma > \gamma_2\end{aligned}$$

with

$$\gamma_2 = \frac{(1-w)G}{(1-r)L + (1-w)G}.$$

Note that $r > w$, $G > 0$ and $L < \infty$ imply $\gamma_2 > \gamma_1$. Figure 3 displays the signal-contingent reaction functions of the judge for the case of $\gamma_1 > 0$ and $\gamma_2 < 1$. The reaction function $\alpha^*(\gamma)$ is represented by the dashed line. The straight line represents the reaction function $\beta^*(\gamma)$.

Figure 3: The judge's reaction functions $\alpha^*(\gamma)$ and $\beta^*(\gamma)$

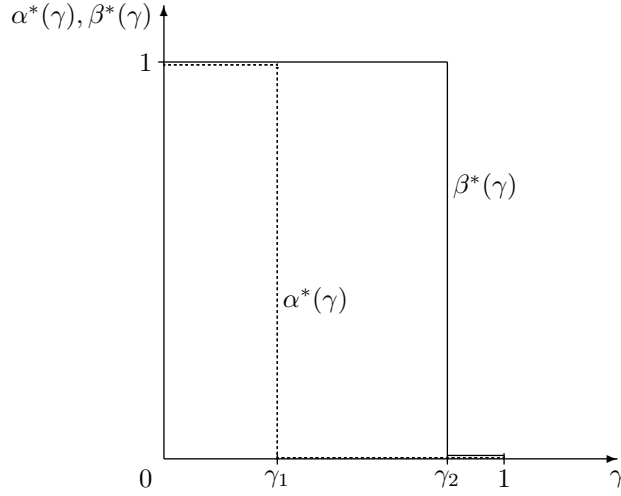

The figure shows that there is no value of γ for which $\alpha^*(\gamma) > \beta^*(\gamma)$ holds. Furthermore, for $\gamma = \gamma_1$ or $\gamma = \gamma_2$, exactly one of the judge's optimal behavioral strategies α^* or β^* is mixed while the other one is pure. These observations are important for the subsequent equilibrium analysis.

3.3 Bayesian Monitoring Equilibria

In the previous section, I have derived the judge's reaction functions $\alpha^* = \alpha^*(\gamma)$ and $\beta^* = \beta^*(\gamma)$, as well as the suspect's reaction function $\gamma^* = \gamma^*(\alpha, \beta)$. An equilibrium combination of behavioral strategies is given by $\alpha^*(\gamma^*), \beta^*(\gamma^*)$, and $\gamma^*(\alpha^*, \beta^*)$. Proposition 1 presents the behavioral strategy combinations which characterize the three Perfect Bayesian Equilibria.

Proposition 1: In the Bayesian Monitoring Game with $G, L > 0$ and $0 < w < r < 1$, the Perfect Bayesian Equilibria are characterized by the following combinations of behavioral strategies:

1. **tyrannic:** $\gamma = 0$ and $\alpha = \beta = 1$,
2. **draconian:** $\gamma = \gamma_1$ and $\alpha = 1 - K, \beta = 1$,
3. **lenient:** $\gamma = \gamma_2$ and $\alpha = 0, \beta = K$,

$$\text{with } K = \frac{B}{(r-w)P}, \gamma_1 = \frac{wG}{rL+wG} \text{ and } \gamma_2 = \frac{(1-w)G}{(1-r)L+(1-w)G}.$$

The tyrannic equilibrium is the only one in pure strategies. The draconian equilibrium is characterized by a low rate of compliant (“good”) behavior, as the suspect faces positive probability of being sanctioned after both signal realizations. In the lenient equilibrium, the threat of sanctions is rather moderate (only after the bad signal realizations, and then with a probability smaller than one), and the rate of good behavior is the highest. In Figure 4 the three equilibria are shown as bold dots.

The first result is rather straightforward: if the suspect chooses bad behavior, and the judge punishes regardless of the signal realization, both parties will be confirmed in their decisions and beliefs by the other party's behavior. In this equilibrium, the ex-post beliefs of the judge are $\mu = \nu = 0$. However, in comparison to the well-known inspection game, this outcome is surprising, as the latter does not exhibit pure strategy equilibria.

The third result establishes that it can be rational for a suspect to frequently choose good behavior under costless judicial monitoring if the judge never punishes after having observed $i = g$ and only occasionally after $i = b$. In this

Figure 4: Bayesian Monitoring Equilibria

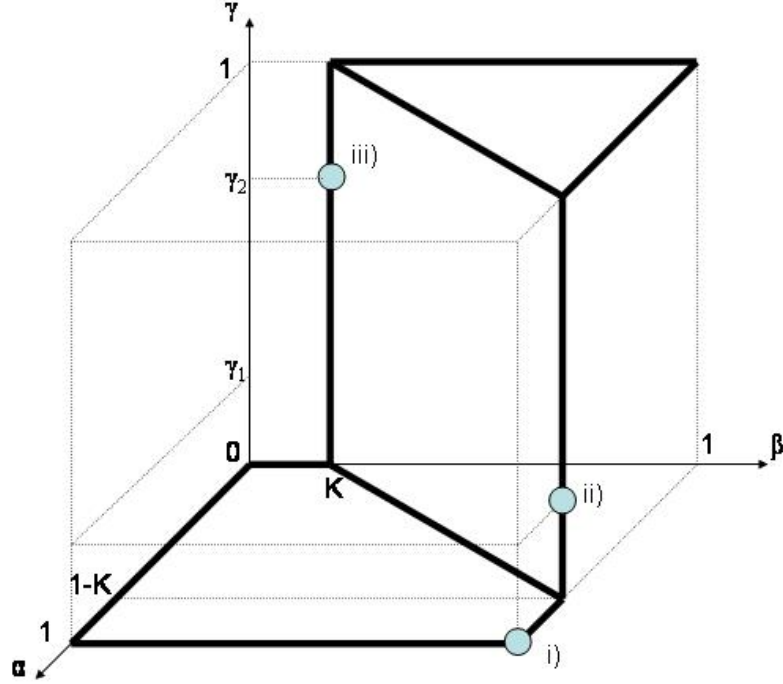

equilibrium, the monitor's ex-post beliefs are

$$\mu = \frac{r\gamma_2}{r\gamma_2 + w(1 - \gamma_2)} = \frac{r(1 - w)G}{r(1 - w)G + w(1 - r)L}$$

and

$$\begin{aligned} \nu &= \frac{(1 - r)\gamma_2}{(1 - r)\gamma_2 + (1 - w)(1 - \gamma_2)} \\ &= \frac{(1 - r)(1 - w)G}{(1 - r)(1 - w)G + (1 - w)(1 - r)L} = \frac{G}{L + G}. \end{aligned}$$

The equilibrium belief ν is independent of (r, w) , as the equilibrium choice of β neutralizes the signal's imperfection.

Result 2 has a rather strange property. The judge can induce the suspect to choose good behavior with probability γ_1 if he always punishes her after

having observed the bad signal ($\beta^* = 1$) and also punishes her with a positive probability after having observed the good signal ($\alpha^* > 0$). However, the resulting probability of good behavior is lower than in the lenient equilibrium. In both mixed strategy equilibria, the monitor is required to choose $\beta > \alpha$. If the distance between these two signal-contingent punishment probabilities is calibrated adequately, then the suspect is indifferent between her pure strategies. This effect can either be attained by choosing $\alpha = 0$ and an adequately high $\beta < 1$, or by choosing $\beta = 1$ and an adequately low $\alpha > 0$. The monitor's ex-post beliefs in the second mixed strategy equilibrium are

$$\mu = \frac{r\gamma_1}{r\gamma_1 + w(1 - \gamma_1)} = \frac{rwG}{rwG + wrL} = \frac{G}{G + L}$$

and

$$\nu = \frac{(1 - r)\gamma_1}{(1 - r)\gamma_1 + (1 - w)(1 - \gamma_1)} = \frac{(1 - r)wG}{(1 - r)wG + (1 - w)rL}.$$

Now, it is the equilibrium choice of α that makes the ex-post belief μ independent of the signal quality. The impossibility of implementing good behavior with certainty is directly implied by Proposition 1:

Corollary: In the Bayesian Monitoring Game with $0 < w < r < 1$, $G > 0$, and $L > 0$, neither the judicial strategy ($\alpha = 0, \beta = 1$), nor the suspect's strategy $\gamma = 1$ is part of a Perfect Bayesian Equilibrium.

This result formalizes what was mentioned verbally in the introduction: if the judge chooses $\alpha = 0$ and $\beta = 1$, this would indeed induce the suspect to choose $\gamma = 1$. However, the judge's best reply to $\gamma = 1$ would be ($\alpha = \beta = 0$) and not ($\alpha = 0, \beta = 1$). If the judge expects the suspect to choose good behavior with certainty, then it would be irrational to rely on an imperfect signal when deciding whether or not to punish. To follow the signal would mean to punish the suspect falsely with a positive probability, namely w . The judge can, however, avoid any wrongful punishment by simply disobeying the signal realization and not punishing at all ($\alpha = \beta = 0$). Therefore, ($\alpha = 0, \beta = 1$) cannot be part of

an equilibrium. However, this induces the suspect to choose bad behavior. The suspect's best reply to $\alpha = \beta = 0$ is not $\gamma = 1$, but $\gamma = 0$, so $\gamma = 1$ is never an equilibrium strategy. Note that this result occurs even though the judge is benevolent (i.e. prefers correctly issued sanctions) and the monitoring signal is costless. The reason for this Corollary is the assumed imperfectness of the monitoring signal.

3.4 Discussion

3.4.1 Comparative Statics

The equilibrium analysis reveals that the judge's behavior does not depend on his own payoff parameters. The only parameters which influence his behavioral strategies in the equilibria are B, P, r and w . In the lenient equilibrium, the probability of punishment after having observed the signal realization $i = b$ is $\beta^* = K$ with $K = B/[(r - w)P]$. Comparative statics shows that

$$\frac{\partial \beta^*}{\partial B}, \frac{\partial \beta^*}{\partial r} > 0 > \frac{\partial \beta^*}{\partial P}, \frac{\partial \beta^*}{\partial w}.$$

In the lenient equilibrium, a better signal quality (higher r or lower w), a higher suspect's benefit B , or a lower sanction S increase the probability of punishment after the judge has observed the bad signal realization.

The suspect chooses good behavior with probability γ_2 , which depends on r, w, L and G . The signs of the partial derivatives are

$$\frac{\partial \gamma_2}{\partial G}, \frac{\partial \gamma_2}{\partial r} > 0 > \frac{\partial \gamma_2}{\partial L}, \frac{\partial \gamma_2}{\partial w}.$$

The probability of good behavior can be increased by increasing the judicial reward for correct decisions, by lowering his disutility for wrong decisions, or by increasing the signal quality.

In the draconian equilibrium, the judge chooses a mixed punishment strategy $\alpha^* = 1 - K$ only after observing the good signal realization. The signs of the partial derivatives are:

$$\frac{\partial \alpha^*}{\partial B}, \frac{\partial \alpha^*}{\partial r} < 0 < \frac{\partial \alpha^*}{\partial P}, \frac{\partial \alpha^*}{\partial w}.$$

The draconian equilibrium induces the suspect to choose good behavior with probability γ_1 . Again, this probability only depends on r, w, L and G . The signs of the partial derivatives are

$$\frac{\partial \gamma_1}{\partial G}, \frac{\partial \gamma_1}{\partial w} > 0 > \frac{\partial \gamma_1}{\partial L}, \frac{\partial \gamma_1}{\partial r}.$$

In this equilibrium, the signal quality has a negative impact not only on the probability of wrongful punishment α^* , but also on the probability of good behavior γ_1 . The first of these insights is self-evident. The second is surprising, but it is implied by the first one. Better signal quality reduces the risk of wrongful punishment. Therefore, it requires a lower value of γ to keep the draconic judge indifferent between his pure strategies.

3.4.2 Perfect or Uninformative Signals

The next proposition is concerned with two extreme cases of signal quality which were excluded in the above analysis: an uninformative and a perfect signal.

Proposition 2: Consider the Bayesian Monitoring Game with $G > 0$ and $L > 0$. If $r = w$, then the equilibrium behavioral strategies are $\gamma = 0$ and $\alpha = \beta = 1$. If $r = 1$ and $w = 0$, then the unique subgame perfect equilibrium is $\alpha = 0, \beta = 1, \gamma = 1$.

The first part of Proposition 2 considers a judge who has no monitoring skill, i.e., with $r = w$. Then, the first derivative of the suspect's yield function would always be negative, implying $\gamma^* = 0$. Hence, the suspect would always choose bad behavior. The judge's best reply would be to always punish with positive probability. As $r = w$ and $G, L > 0$ imply $\gamma_1 = \gamma_2 > 0$, the judge chooses $\alpha = \beta = 1$.

The second part of the proposition concerns a judge of perfect monitoring skill, who evaluates the case without errors ($r = 1$ and $w = 0$). This reduces the game to a one with perfect information, a sequential version of the inspection game (with zero monitoring cost). The judge's best reply to good behavior is acquittal, while bad behavior will be punished. Draconic punishment, combined

with $\gamma = 0$ is also a Nash equilibrium of this game, but perfect compliance as described in the proposition is the only subgame perfect equilibrium. Hence, Bayesian monitoring can only induce the suspect to comply with certainty if the monitoring signal is perfect.

3.4.3 Judicial Payoffs

The derived results depend on the assumptions $G > 0$ and $L > 0$: The judge must derive utility from correct judgements and disutility from wrong ones. Without such incentives ($G = L = 0$), monitoring would have no impact on the suspect's behavior, as this would imply $\gamma_1 = \gamma_2 = 0$. However, it is sufficient for the derived results that G and L are positive, even if the values of these parameters are negligible compared to B , X , and P .

4 Conclusions

The results of the Bayesian Monitoring Game presented here show four differences from enforcement models in the tradition of Becker (1968):

- While in the Becker model the enforcement system either produces perfect deterrence or no deterrence at all, total deterrence is never part of a Bayesian Monitoring Equilibrium. In all three Perfect Bayesian Equilibria derived above, the probability of good behavior is smaller than one; bad behavior occurs with positive probability.
- In the model presented here, there is no simple trade-off between the sanction and the probabilities with which punishment is issued. Furthermore, the maximum fine result of Becker (1968) is not sustained by this model. Endogenizing the sanction would not alter the suspect's incentives, as her mixed strategy is not influenced by the height of the punishment.
- Moreover, the equilibrium probability of good behavior is independent of the external damage, the initial wealth, and the internalized benefit of bad behavior. The suspect's equilibrium strategy only depends on the

parameters which reflect the judicial preference for correct judgements as well as the quality of the judicial monitoring signal.

- The signal dependent probabilities of punishment are independent of the suspect's initial wealth and the negative externality caused by bad behavior. The rational judge only takes into account the size of the sanction, the suspect's benefit from bad behavior and the signal quality when choosing his mixed strategy.

Even with costless signals and judicial benevolence, perfect enforcement cannot be reached when the judge's signal is only imperfect. The best outcome which can be attained is a high probability of good behavior, as bad behavior is inefficient by assumption.

The model presented here shares some features with the inspection game. The difference with regard to the assumptions concerns the monitoring signal. In the inspection game, it is costly and perfect, here it is costless but imperfect. With regard to the results, the Bayesian Monitoring Game exhibits two mixed strategy equilibria and one in pure strategies, while the inspection game has only one mixed strategy equilibria. The Bayesian Monitoring Game can, therefore, provide a positive explanation for different monitoring styles. These styles are characterized by the different signal-contingent punishment probabilities. Moreover, the different punishment styles induce different probabilities with which the suspect chooses good behavior.

Comparative statics reveals that the signal quality governs both parties' behavior. While a higher signal quality increases the probability of good behavior in the lenient monitoring equilibrium, it has the opposite impact in the draconian equilibrium. This reflects the suspect's reaction to a lower probability of wrongful punishment by a draconian judge to whom a better signal is available. Punishment and compliance in the tyrannic equilibrium are independent of the payoff and signal quality parameters.

A policy implication from these results would be that society should employ means to facilitate equilibrium selection of the lenient monitoring style. In this equilibrium, investment in higher signal quality may improve compliance. In the

draconian equilibrium, such investment would be counterproductive; as long as the signal is informative, a lower signal quality leads to higher compliance rates (which are, however, on a low level).

An important property of the Bayesian model presented here is the stochastic involvement of judges. In models like Kirstein/Schmidtchen (1997), the judges remain inactive when the parameters of the court system are adequately set and the contracting parties comply with the law. They act in the “shadow” of the courts, and the judges remain off the equilibrium path. If, however, the parameters are set suboptimally, then each case is brought to court or cooperation collapses completely. In a mixed strategy Bayesian Monitoring Equilibrium, however, the judge may become active with positive probability. This is certainly closer to reality.

References

- Alexander, J.C. 1994:** Judge’s Self-Interest and Procedural Rules: Comment on Macey; in: *The Journal of Legal Studies* 23, 647-665.
- Anderson, G.M./Shugart, W.H./Tollison, R.D. 1989:** On the Incentives of Judges to Enforce Legislative Wealth Transfers; in: *Journal of Law and Economics* 32, 215-228.
- Andreozzi, L. 2004:** Rewarding Policemen Increases Crime. Another Surprising Result From the Inspection Game; in: *Public Choice* 121, 69-82.
- Baiman, S./May, J.H./Mukherji, A. 1990:** Optimal Employment Contracts and the Returns to Monitoring in a Principal-Agent Context; in: *Contemporary Accounting Research* 6(2), 761-799.
- Baker, M.J./Miceli, T.J. 2005:** Credible Criminal Enforcement; in: *European Journal of Law and Economics* 20, 5-15.
- Baliga, S./Corchon, L.C./Sjöström, T. 1997:** The Theory of Implementation When the Planner Is a Player; in: *Journal of Economic Theory* 77, 15-33.
- Becker, G.S. 1968:** Crime and Punishment: An Economic Approach; in: *Journal of Political Economy* 76, 169-217.
- Berentsen, A./Brügger, E./Lörtschler, S. 2003:** On Cheating and Whistleblowing; Insitute for Empirical Research in Economics, University of Zurich, Working Paper No. 153.
- Bianco, W.T./Ordeshook, P.C./Tsebelis, G. 1990:** Crime and Punishment: Are One-Shot, Two-Person Games Enough? In: *American Political Science Review* 84(2), 569-586.

- Cheng, P. 1990:** Discussion of “Optimal Employment Contracts and the Returns to Monitoring in a Principal-Agent Context”; in: *Contemporary Accounting Research* 6(2), 804-808.
- Faure-Grimaud, A./Laffont, J.-J./Martimort, D. 2003:** Collusion, Delegation and Supervision with Soft Information; in: *Review of Economic Studies* 70, 253-279.
- Feddersen, T./Pesendorfer, W. 1998:** Convicting the Innocent: The Inferiority of Unanimous Jury Verdicts under Strategic Voting; in: *American Political Science Review* 92(1), 23-35
- Graetz, M.J./Reinganum, J.F./Wilde, L.L. 1986:** The Tax Compliance Game: Toward an Interactive Theory of Law Enforcement; in: *Journal of Law, Economics, and Organization* 2(1), 1-32.
- Hadfield, G.K. 1994:** Judicial Competence and the Interpretation of Incomplete Contracts; in: *The Journal of Legal Studies* 23, 159-184
- Heiner, R.A. 1983:** The Origin of Predictable Behavior; *American Economic Review* 73, 560-595
- Heiner, R. A. 1986:** Imperfect Decisions and the Law: On the Evolution of Legal Precedent and Rules; in: *The Journal of Legal Studies* 15, 227-261
- Holler, M. 1990:** The Unprofitability of Mixed-Strategy Equilibria in Two-Person-Games. A Second Folk Theorem; in: *Economics Letters* 32, 319-323.
- Jost, P.-J. 1997:** Regulatory Enforcement in the Presence of a Court System; in: *International Review of Law and Economics* 17(4), 491-508
- Khalil, F. 1997:** Auditing without Commitment; *RAND Journal of Economics* 28(4), 629-640.
- Khalil, F./Lawarrée 1995:** Collusive Auditors; in: *The American Economic Review* 85(2), 442-446.
- Kirstein, R./Schmidtchen, D. 1997:** Judicial Detection Skill and Contractual Compliance; in: *International Review of Law and Economics* 17(4), 509-520
- Macey, J.R. 1994:** Judicial Preferences, Public Choice, and the Rules of Procedure; in: *The Journal of Legal Studies* 23, 627-646.
- Mirrlees, J.A. 1999:** The Theory of Moral Hazard and Unobservable Behavior: Part I; in: *The Review of Economic Studies* 66(1), 3-21.
- Polinsky, A.M./Shavell, S. 2000:** The Economic Theory of Public Enforcement of Law; in: *Journal of Economic Literature* 38, 45-76.
- Posner, R.A. 1994:** What do Judges and Justices Maximize? (The Same Thing Everybody Else Does); in: *Supreme Court Economic Review* 3, 1-41.
- Reinganum, J.F./Wilde, L.L. 1986:** Equilibrium Verification and Reporting Policies in a Model of Tax Compliance; in: *International Economic Review* 27(3), 739-760.

- Reinganum, J.F./Wilde, L.L. 1985:** Income Tax Compliance in a Principal-Agent Framework; in: *Journal of Public Economics* 26, 1-18.
- Schwartz, E.P. 1995:** A Comment on “The Appeals Process as a Means of Error Correction”, by Steven Shavell; in: *Legal Theory* 1, 361-363.
- Shavell, S. 1995:** The Appeals Process as a Means of Error Correction; in: *The Journal of Legal Studies* 24(2), 379-426.
- Shavell, S. 1996:** Reply to a Comment on “The Appeals Process as a Means of Error Correction”; in: *Legal Theory* 2, 83-85.
- Swets, J.A. 1988:** Measuring the Accuracy of Diagnostic Systems; in: *Science* 240, 1285-1293.
- Swets, J.A. 1996:** Signal Detection Theory and ROC Analysis in Psychology and Diagnostics. *Collected Papers*; Mahwah, NJ.
- Tsebelis, G. 1989:** The Abuse of Probability in Political Analysis: The Robinson Crusoe Fallacy; in: *American Political Science Review* 83(1), 77-91.
- Tsebelis, G. 1990a:** Are Sanctions Effective? A Game-Theoretic Analysis; in: *Journal of Conflict Resolution* 34(1), 3-28.
- Tsebelis, G. 1990b:** Penalty Has no Impact on Crime: A Game-Theoretic Analysis; in: *Rationality and Society* 2(3), 255-286.
- Tullock, G. 1980:** *Trials on Trial. The Pure Theory of Legal Procedure*; New York.
- Tullock, G. 1994:** Court Errors; in: *European Journal of Law and Economics* 1, 9-21.
- Wittman, D. 1985:** Counter-Intuitive Results in Game Theory; in: *European Journal of Political Economy* 1(1), 77-89.
- Wittman, D. 1993:** Nash Equilibrium vs. Maximin. A Comparative Statics Analysis; in: *European Journal of Political Economy* 9, 559-565.
- Usman, M. 2002:** Verifiability and Contract Enforcement: A Model with Judicial Moral Hazard; in: *Journal of Law, Economics, and Organization* 18(1), 67-94.