

Falch, M.; Williams, Idongesit; Tadayoni, Reza

Conference Paper

Cross-border Provision of e-Government Business Registration Services

ITS Online Event, 14-17 June 2020

Provided in Cooperation with:

International Telecommunications Society (ITS)

Suggested Citation: Falch, M.; Williams, Idongesit; Tadayoni, Reza (2020) : Cross-border Provision of e-Government Business Registration Services, ITS Online Event, 14-17 June 2020, International Telecommunications Society (ITS), Calgary

This Version is available at:

<https://hdl.handle.net/10419/224852>

Standard-Nutzungsbedingungen:

Die Dokumente auf EconStor dürfen zu eigenen wissenschaftlichen Zwecken und zum Privatgebrauch gespeichert und kopiert werden.

Sie dürfen die Dokumente nicht für öffentliche oder kommerzielle Zwecke vervielfältigen, öffentlich ausstellen, öffentlich zugänglich machen, vertreiben oder anderweitig nutzen.

Sofern die Verfasser die Dokumente unter Open-Content-Lizenzen (insbesondere CC-Lizenzen) zur Verfügung gestellt haben sollten, gelten abweichend von diesen Nutzungsbedingungen die in der dort genannten Lizenz gewährten Nutzungsrechte.

Terms of use:

Documents in EconStor may be saved and copied for your personal and scholarly purposes.

You are not to copy documents for public or commercial purposes, to exhibit the documents publicly, to make them publicly available on the internet, or to distribute or otherwise use the documents in public.

If the documents have been made available under an Open Content Licence (especially Creative Commons Licences), you may exercise further usage rights as specified in the indicated licence.

Cross-border Provision of e-Government Business Registration Services

M. Falch, Idongesit Williams & Reza Tadayoni

CMI, Electronic Systems, Aalborg University Copenhagen,

{falch, idong, reza}@cmi.aau.dk

Abstract

This paper proposes a technical and Public-Private Partnership organizational framework for an electronic identification authentication and trust services (eIDAS), which can be used by private companies to access e-Government services across-borders. The study is supported by the technical scenario and policy solutions. The research is made as a part of the WP3 of an EU funded Interreg project DIGINNO. The study highlights prospects, challenges and policy measures needed to implement the proposed framework and its implication to e-government research.

Keywords: PPP, EIDAS, E-government, G2B, DIGINNO, Business registration.

1. INTRODUCTION

The aim of this paper is to propose a technical and organizational framework for an electronic identification authentication and trust services (eIDAS), which can be used by private companies to access e-Government services cross-border. The specific service in question is cross-border business registration. Cross-border business registration is becoming increasingly important due to the investment opportunities enabled by the free movement of goods and services as well as the mobility of companies within the European Union. These initiatives are governed by EU rules (examples (EUR Lex, 2017) (EUR-Lex, 2012)). These rules among other rules are discussed later in the paper. These rules were aimed at reducing the market entry barriers that hitherto prevented the mobility of companies, goods and services. As a result, EU companies, SMEs and entrepreneurs such as sole proprietors from one member state who identify opportunities in other EU member

states are able to exploit these opportunities based on the EU rules on the free movement of goods and services.

So far, very few companies, SMEs and entrepreneurs in the EU are able to take advantage of the aforementioned EU rules and market dynamics. Larger corporations with the resources, to expand or relocate their operations, are able to take advantage of provisions of the EU policies and regulation promoting the mobility of companies. SMEs are eager to take advantage of the policy provisions; however, they are plagued with other barriers, which makes the mobility of their enterprises expensive. Such barriers include the requirement for residency, prior acquisition of tax identification numbers etc. In order to deal with these challenges, SMEs use third party agencies to facilitate the business registration process. In other cases, the primary applicant has to relocate to the destined member state in order to fulfil some of the requirements required by that member state. These challenges as discussed, later in this paper prevents the free mobility of SMEs and sole proprietors within the EU. Hence, they are unable to exploit opportunities in the same way as the larger corporations.

This problem can be solved in two ways. The first being the harmonization of EU company laws. It is relatively easier to harmonies the sort of documentation needed to register a company. However, harmonizing business registration process can be challenging. The second approach to solving the problem is via the digitalization of the business registration processes nationally and across border. The national digitalization initiative ensures that the service can be accessed digitally nationally. The cross-border digitalization ensures that persons outside the EU member state can remotely register their business without having to travel to another member state. For the latter, what is needed is a trusted digital identity that can identify and verify that the applicant is actually who they claim to be and that they have the right to register the company. This problem can be solved using eIDAS. Obviously, for the second solution (digital solution) to operate efficiently, the EU member state has to amend the business registration process. Therefore, the questions this paper aims to answer are:

- What is the type of technical solution that can be implemented to facilitate cross-border business registration?
- What are the organizational and legal implications of such a technical solution to EU member states?

To answer these questions, the paper proposes a technical and organizational framework using electronic identification authentication and trust services (eIDAS). This framework is aimed at facilitating remote cross-border business registration. The scope for which the framework is developed for is the Nordic and Baltic Sea Region. The framework is developed on basis of research made in the DIGINNO project funded by EU regional development funds. The research is an aspect of the DIGINNO Work package three led by INFOBALT, and Industry association

representing SMEs in Lithuania. DIGINNO is a three year-project (2017-2020) aimed at accelerating the creation of a Digital Single Market in the Baltic Sea Region. The countries represented in the project are Estonia, Denmark, Lithuania, Latvia, Sweden, Finland, Norway, Poland and Germany. Aside, Norway, which is part of the European Economic Area, the other partner countries are EU member states. Apart from Poland and Germany, the adoption of national G2B e-government services by businesses in the countries represented in DIGINNO is above 70% (Linden & al, 2019)[4], and they are among the top ten countries with regard to e-government. In addition, each of these countries are involved in the delivery of G2B cross-border e-government services. Therefore, they are a good case for the investigation of how cross-border G2B services should be designed

The topic for this paper is to present a study on cross-border e-government services offered to businesses in the Nordic Baltic Sea area. The paper is based on research made as part of the EU funded DIGINNO project formed at the initiative of the former Baltic Development Forum. DIGINNO is a three-year project (2017-2020) is part of the Interreg Baltic Sea Region programme and implemented the digitalization umbrella¹.

2. METHODOLOGY

The research was done in two phases. The aim of the phase was to identify key drivers and barriers towards delivery of cross-border e-government business services. This phase included an analysis of current practise with regard to the use of e-government services in the Nordic Baltic Region.

Desktop research identified all in all 77 different services directed towards business. About half of the services were horizontal services offered to all kinds of businesses. The other half was offered to at least one industry sector. The horizontal services included services under the three phases of a business lifecycle: Market entrance, Market activity, and Market exit.

Sixty semi-structured interviews with representatives from selected international companies and associations were carried out. Most of the interviews were made in the Baltic countries, but there were respondents operating in all countries within the region.

¹ More information about the project can be found at <https://www.diginnoobsr.eu/>

About half of the interviews were made with representatives from the land and transport sector. This was not due to a deliberate strategic decision, but simply because actors from this industry were more willing to participate in an interview. A reason for this could be that especially this sector has a keen interest in the project goals.

The findings from this phase point to language, online identification/authentication, document recognition and national regulations as the major barriers. The study also points to the lack of institutional legitimacy for the internationalization of EU G2B services as a barrier to G2B cross border service delivery between the member states (Falch, Williams, & Tadayoni, 2018).

The scope for the second phase was to develop a conceptual design for provision of four different cross-border e-government services to private businesses. The four services were selected according to the business needs for cross-border delivery. The four services were:

- eIDAS – electronic identification of businesses to be used for business registration and other e-government services. This is a necessity for provision of a wide range of e-government services.
- eCMR – electronic consignment notes. This can replace paper based consignment notes, which need to be available for trading and road transport companies, companies, trading partners and road authorities.
- eReceipt – electronic receipts for business transactions. This enables in combination with e-payments and e-invoicing completely paperless financial transactions.
- KYC – Know your customer. This will provide electronic information on private business cross-border. It is an important tool for preventing money laundering and others.

It follows that e-government services are defined broadly, as these services include private as well as public actors. However all of them imply different levels of involvement from public authorities.

This paper focuses on the development of the first of these services.

The next steps were to invite stakeholders to participate in a number of workshops, in order to define business needs and to comment on different options for conceptual design.

Aalborg University, Denmark led in the development of the showcase. They coordinated the hands-on activities in the showcase. They were also in charge of preparing a feasibility report (DIGINNO, 2019). Tallinn Science Park Tehnopol

provided service development training for the showcase development. The showcase members were technocrats from the Norwegian business registrars (The Brønnøysund Register Center), Enterprise Lithuania and the Estonian ministry of economic affairs and communications. These partners in collaboration with Tallinn Science Park Tehnopol executed the framing, and the development of the showcase.

The showcase partners worked in consultation with experts employed by national stakeholders involved in the delivery of national public infrastructure and services in their countries. These experts provided insight into the problems identified in the showcase and the prospective solutions. The affiliations of these experts are represented in the table below.

Table 1 List of stakeholders involved in development of the eIDAS showcase

	Country	Organization (s)
1	Denmark	<ul style="list-style-type: none"> • Danish Business Authority (Danish Business Registrars) • Danish Agency for Digitization (Agency responsible for public sector digitization in Denmark)
2	Norway	<ul style="list-style-type: none"> • The agency for Public Management and e-government (DIFI) (Agency responsible for public sector digitization in Norway)
3	Lithuania	<ul style="list-style-type: none"> • Information Technology and Communication Department under the Ministry Of Interior, • The Migration Department under the Ministry Of Interior, • Information Society Development Committee under the Ministry of Economy, • State Tax Inspectorate Under the Ministry of Finance of the Republic of Lithuania • The State Enterprise Centre of Registers
4	Estonia	<ul style="list-style-type: none"> • Information System Authority ¹

Source: (DIGINNO, 2019)

3. BACKGROUND

This section defines cross-border e-government services and provides a rationale for its implementation in the Baltic Sea Region and in the EU. E government in this paper implies the delivery of government services using the Internet based

technologies (Ersoz & Askeroglu, 2020). There are four major forms of e-government. These are Government-to-Business (G2B), Government-to-Citizen (G2C), Government-to-Government (G2G) and Government-to Employees (Ghareeb, Darwish, & Hefny, 2020). As nations around the world adopt e-government, these forms of e-government are evident. However, e-government is increasingly transcending national boundaries (Williams, 2020). The delivery of e-government services either to citizens of another country or between two or more countries is referred to as cross-border e-government. Cross-border e-government services occur in three ways. These are unilateral cross-border e-government service delivery, bilateral/multilateral cross-border e-government service delivery and regionally coordinated cross-border e-government delivery (Williams, 2020). The reason for these emerging forms of cross-border service delivery is due to globalization. Globalization has given rise to the increase in migration and international trade. The increase in migration has opened up the opportunity for cross-border G2C services while the increase in international trade has opened up the opportunity for G2B cross border services.

Australia is an example of the countries that have utilized unilateral, G2C cross-border services. They provide an online portal where foreigners from eligible countries can apply for certain classes of visas online. Hence, the applicant does not need to visit the Australian embassy in his or her country. In the case of G2B, countries such as Denmark provide the possibility for non-residents to register their enterprise in Denmark. The application process is online and the applicant does not need to fulfil the residency requirement at the time they register their business (DIGINNO, 2019) (Williams, Falch, & Tadayoni, 2018). Another example is the Estonian E-residency programme, which is discussed later in this chapter. There are also examples of bilateral G2G initiatives. Finland and Estonian Business Registry and e-prescription infrastructure are now exchanging data. Hence, if a Finn decides to register a company in Estonia, it is easy for the Estonian business registrar to retrieve data from the Finnish Business registrar. In the same vein, digital prescriptions issued in Estonia are recognized in Finland and vice versa. Finally, an example of a regionally coordinated e-government cross-border service delivery is in the EU. In the EU the vision is to develop a Digital Single Market that exists as a whole and not fragmented.

Cross-border e-government services are an extension of national e-government services. That is because the cross-border dimension would not exist if the public service provider has neither a national e-government service nor infrastructure. Hence as a natural progression current cross-border e-government services are citizen or user centric. Currently however not provided as an obligation but based on need, hence it is currently a value driven e-government service.

Although there are various cross-border e-government initiatives around the world, it is in the EU where there is a conscious effort to implement cross-border e-

government services. e-government is an important part of the EU Digital Single Market Strategy. A European e-government Action plan 2016-2020 was adopted in 2016 (EUROPEAN COMMISSION, 2016). It includes three priority areas were mentioned:

- Modernising public administrations using key digital enablers (for example technical building blocks such as CEF DSIs like eID, eSignature, eDelivery, etc.),
- Enabling mobility of citizens and businesses by cross-border interoperability,
- Facilitating digital interaction between administrations and citizens/businesses for high-quality public services.

Cross-border e-government services are important elements in this plan, as they contribute to all of these three areas. This paper focuses on cross-border government services provided to businesses.

e-government are often associated with provision of digital public services to private businesses. While many papers focus on e-government services provided to citizens much less research is done with regard to services aimed for private businesses. For instance are the EU benchmark indicators included in EU E-government report measuring the uptake of digital government services by individuals, while corporate use is not included (Commission, 2018).

However digitalisation of public services in particular services provided to private businesses is equally important, as it has a more direct impact on digitization of companies, and can be seen as a policy tool facilitating IT innovation in private businesses. Digitalization of communication between private companies and public institutions can reduce transaction costs and improve services delivered. This digitalization can be either mandatory or offered as an opportunity for private companies. Mandatory digitalization may increase costs for some companies in the short term. On the other a mandatory transition will speed up the process, a critical volume of transactions will be achieved almost immediately, and this will benefit both public and private actors.

It is based on this rationale that DIGINNO partners ,in collaboration with external project partners, decided to develop the technical and organizational framework that will help business registrars in the Baltic Sea Region handle cross-border business registration. It will also further reduce the market entry barrier; enabling businesses register their business remotely using eIDAS. The Baltic Sea Region is an interesting area to study, when it comes to development of ICT services. Although the countries in the Baltic See Region to a certain extend share a common history from medieval times, the countries are diverse with regard to culture and economic development. The Nordic countries have for more than a decade been among the leaders with regard to use of ICT services. The Baltic countries can be characterized

as emerging ICT economies, as they have experienced a tremendous growth in ICT within the past decade, and today especially Estonia is among the most advanced countries in the EU. In addition both the Nordic and the Baltic countries are small open economies with a high focus on cross-border operations.

The next section provides an insight into the relationship between Cross-border mobility of Business, eIDAS and business registration.

4. CROSS BORDER MOBILITY OF BUSINESS, eIDAS AND BUSINESS REGISTRATION.

4.1. Cross Border Mobility of Business

Cross-border mobility of businesses is an essential aspect of the EU's single digital single market (Williams, Falch, & Tadayoni, 2018). These mobilities could either be in the form of relocation, mergers, conversions, or the opening of new branches. Cross-border mobility of businesses enables “want to be” entrepreneurs, SMEs and large corporations take advantage of market, labor, capital, operational and productivity possibilities that may not exist in their present location. Based on a survey conducted by Ernest & Young, SMEs embrace the possibilities provided by free movement of businesses. This is especially so in the case of the EU where more than three quarters of companies in the continent are SMEs.

The free movement of goods and services in the EU necessitates the idea behind cross-border mobility of businesses. These ideas are institutionalized in the EU via treaties such as Treaty establishing the European Community in 2002 and the Treaty on the Functioning of the European Union in 2012 (EUR-Lex, 2012) (EUR-Lex, 2002). In both treaties, the freedom of goods and services in the EU is promoted and one of the avenues towards the free movement of goods and services was the reduction in the entry barrier towards company registrations by foreign EU company representatives. Both EU treaties mandate that foreign EU Company “be treated in the same way as natural persons” in the destined member states (ibid). This in principle implied that EU companies would be treated without distinction from national companies. This implies whatever rights and EU Company has in that member state automatically applies to such the EU company being registered. Equalizing the status of the foreign EU company and the national existing local national company implies that the EU company can transport goods and services under the same conditions as the local national companies.

The ideas have also been institutionalized in recent EU company regulations. An example is The COUNCIL REGULATION (EC) No 2157/2001 which establishes the “European Company” or the “Societas Europaea” (SE) (EUR -Lex, 2001). This

is a public limited liability company established within the EU. It allows company owners to transfer their company from one EU jurisdiction to the other without having to close down operations (ibid). This enables the company to become mobile and not being bogged down by national laws on winding company operations. Another example is the Council Regulation (EEC) No 2137/85 which establishes the European Economic Interest Grouping (EEIG) (EUR LEX, 1985). The EEIG enable two companies in different member states to cooperate as a joint venture. Another example worth mentioning, even though it was withdrawn is Document 52014PC0212 (EUR Lex, 2014). This was a proposed directive on single-member private limited liability companies (Societas Unius Personae). The proposal is to enable the setting up of single shareholder companies across borders within the member states. This will enable sole proprietors operate cross-border companies. Unfortunately this directive was withdrawn.

Nevertheless, it could be said that the aforementioned institutions among others were setup to facilitate cross-border mobility of businesses. So despite these institutional initiatives there are indications from a study conducted by Ernest and Young that cross-border mobility of businesses is low in the EU (DG Just, 2018). In 2017 there were 27.5 Business enterprises in Europe (Eurostat, 2020). In the study conducted by Ernst and Young, 600 EU companies expand their operations annually while 100 EU companies shift their operations annually (DG Just, 2018). The study highlighted that companies do not find mobility attractive in the EU due to cumbersome business registration processes (DG Just, 2018). Although EU business law regulations and directives have been aimed at harmonizing national rules on company laws, Findings in the DIGINNO project highlights that business registration laws are not harmonized and fraught with national bureaucracies. The level of bureaucracy varies from country to country. Aside this challenge it is also evident that the market entry barrier for forming Societas Europaea and EEIGs is high for small businesses. For example the Societas Europaea requires a minimum share capital of 120 000 Euros. Similarly for the EEIG, the collaborating companies, though not required but due to the nature of cross-border projects, ought to have the financial muscle to engage in such an endeavor. These challenges are not from the businesses, rather they emanate from the national company laws from different EU member states and the EU in case of the Societas Europaea.

The approach adopted by the EU parliament in solving this challenges, among other challenges not related to the company law, was the adoption of the EU E-government action plan of 2017 (Williams, Falch, & Tadayoni, 2018). This is an e-government plan that evolve from EU e-government policy and the Malmo declaration (ibid). The plan adopted by the EU parliament emphasized (in point 25) the need for creating e-Government cross-border services (EU parliament, 2017). This emphasis had an implication on the governance of the business life cycle. Hence, cross-border business registration processes had to be handled using digital tools. Furthermore, national business registrars across the EU had to be interconnected in order to share data. Technical solutions that have emerged from

EU projects to support these ideas were the e-Justice portal and the Business Registers Interconnection Systems (DIGINNO, 2019). Nevertheless, by 2019 Directive (EU) 2017/1132 was amended to authorize business registration using digital tools. The challenge with this solution is that it neither results in the harmonization of national rules in company law nor reduce the high entry barrier for the *Societas Europaea* and the EEIG. Rather is it a step towards allowing member states to maintain their laws, while a technical solution is used to enable cross-border business registration using the European Interoperability Framework.

In order to contribute to this solution, DIGINNO partners identified three challenges that had to be solved in order to enable cross-border business registration. Business registrars in the project identified these challenges. The first challenge was that of identifying that a legal person registering the business. The second challenge was that of verifying the identify of the natural and legal person. The third was the ability to deliver the service in a language (*lingua franca*) of the applicant. For the first two challenges, DIGINNO partners opted for the eIDAS framework. In the next section, we will discuss how eIDAS supports business registration. That will be followed by the proposed technical solution proposed to facilitate cross-border business registration in the EU.

4.2. EIDAS

Overview on EIDAS

Electronic Identification, Authentication and Trust Services (EIDAS), is the technical standard used for the electronic identification and trust services in the European Union's internal market. It is one of the technical drivers for the development of a Digital Single market in the EU. The standard was backed initially by the EU EIDAS directive and later the EU EIDAS regulation (Williams, Falch, & Tadayoni, 2018). The regulation regulates the utilization of eIdentity and e-signatures in the performance of electronic transactions for Public and private (optional) service delivery. The regulation also mandates the compulsory adoption of EIDAS technical standards by public agencies in the EU as means of verifying the identity of citizens and businesses that access these public services (CEF Digital, 2019). The mandatory adoption of the standards by the national eID providers opens up the possibility of mutual eID recognition when businesses and citizens from different EU member states access public services in other EU member states.

There are different EIDAS attribute frameworks for citizens and businesses respectively. The framework for the citizen identifies the individual, while the framework for company identifies the legal entity. Public services that deal with company representatives use both. Nevertheless, an important aspect of these frameworks, among other technical details, is the EU decision on the attributes (data set) that accompany each EID. At the national level, these attributes enable citizens and businesses to access public service portals as well as perform transactions.

However, not all but selective data sets are attached to an eID from different national registrars accompany each eID for every public service accessed. Hence, public service officials only have access to data sets that of either the business or citizen as it applies to the service. Developing such a scheme at a continental level is complicated, but will be done over time. Examples of such initiatives are planned in the Nordic EID project, using EIDAS. However, for now, EIDAS has a minimum set of mandatory attributes that are linked to national eIDs. The mandatory eIDAS attribute for natural persons (citizens) are represented in the table below.

Table 2: EIDAS mandatory attributes for natural persons

Attribute (Friendly) Name	eIDAS MDS Attribute
FamilyName	Current Family Name
FirstName	Current First Names
DateOfBirth	Date of Birth
PersonIdentifier	Unique Identifier

Source (CEF Digital, 2019)

The mandatory eIDAS attributes for legal persons are represented in the table below.

Table 3: EIDAS Mandatory Attributes for legal persons

Attribute (Friendly) Name	eIDAS MDS Attribute
LegalName	Current Legal Name
LegalPersonIdentifier	Uniqueness Identifies

Source (CEF Digital, 2019)

However, these mandatory attributes does not enable transactions, rather they enable access to the public service infrastructure. Legal barriers are the reasons for the inability for these mandatory EIDAS attributes to enable transaction. This is because different national public service regulations defines the criterion and relevant attributes needed to access services they govern. One approach provided by EIDAS to circumnavigate this problem is the provision for optional attributes. However currently, the EIDA standard does not provide a framework for the technical request and delivery of the optional attributes in real time. This is especially so in cases where the optional attribute that could be requested does not exist in the country with the originating eID. Despite this deficiency EIDAS

provides the possibility of enabling access to public sector delivery. This was why it was adopted in this project.

Overview of eID and business registration in the EU and the need for EIDAS

EU and national Company laws govern business registration in EU member states. Despite the existence of the EU company law, national company laws possess diverse additional regulations governing the lifecycle of a business. In DIGINNO the phase of the company life cycle of interest was that of market entry. To be specific- the business registration process.

Business registration process varies from jurisdiction to Jurisdiction. In the Nordic countries, these processes are online. Nevertheless, one is unable to register their business in these regions unless you possess the national eID. Owning an eID is not possible if you are not a legal resident of that country. However, in Denmark, a company representative could start the business registration process and later receive an eID before becoming a legal resident in Denmark (DIGINNO, 2019). In the Baltics, the situation is not so different. This is because aside Estonia, in Lithuania and Latvia, all processes as one registers the business are not online. However, in the case of Estonia, legal persons around the world can register their business in Estonia using the e-residency program (CIVITTA, 2018) (DIGINNO, 2019). Aside that, as a means of sustaining the output of the STORK project (a predecessor for eIDAS), legal persons from Lithuania, Finland, and Latvia can access the Estonian business registry using their eID. Furthermore, in Lithuania they are the press of building the national registry for foreigners. This will enable them provide eIDs to foreign legal persons. Currently it is only Lithuanians that own Lithuanian eIDs, In the other EU member states, the inability to register a business without being a legal resident of the country is possible in very few countries. Furthermore, in these countries such as Germany (some regions), not all business registration processes are online both for local and foreign businesses (Falch, Williams, & Tadayoni, 2018). This implies that there are cases where national eID schemes are not utilized for business registration processes. In the EEA, Norway and now the UK have online business registration processes. But registering a business in these countries still residence (DIGINNO, 2019).

Although it is obvious that different countries are different stages of facilitating full online service delivery, there is a problem with those with online business registration processes. That has to do with the residency requirement backed by the ownership of eIDs. This problem becomes magnified in the sense that these national eIDs use different standards resulting in the lack of interoperability between different eID infrastructure. This situation exist because there are differences in eID schemes and how these schemes are governed and operated. In most countries these schemes are operated by one or more private entities. Very few countries have these schemes centrally governed by their digitalization agencies. As a result the EU came

up with EIDAs as a solution. Hence as mentioned earlier a continental standard is created which enables the mutual recognition of eIDs across border.

Although different countries are at different stages in the development of their business registration infrastructure, once developed foreign businesses in the EU we able to access business registration systems in other EU jurisdictions.

4.3. EIDAS adoption and business registration in the EU

Although EIDAs only enables access to public services, it still has some value to business registrars. This is because it enables the identification and authentication of the identity of Businesses and their legal representatives. This is necessary for business registrars to ascertain that the company representative is legitimate and not an impersonator. Based on this value, Business registrar in some EU and EEA have adopted eIDAs for the identification of citizens and businesses. Examples include Denmark, Germany (some regions), and Netherlands etc.

However, different countries are at different stages in the development of their EIDAS infrastructure. Once such infrastructure is developed, it goes through a pre-notification, an optional peer-review and a notification process. The pre notification process enables citizens and businesses of the originating eID to access public services in other EU member states. It also reveals the minimum attributes that accompanies each eID for personal identification (citizens) and business. The peer review process is optional but it enables other member states to conduct a peer review of the 'to be notified' eID. The notification involves the EU publishing the notified scheme. This implies that there is mutual recognition of the eID, and the assurance level it provides. Notification does not imply that the eID infrastructure is connected to a service. It implies that the notified eID conforms with the EIDAS guidelines and that it is mutually recognized. Different countries now need time to connect services to the new eID.

However, at the time of investigation in the DIGINNO project, Germany and Estonia were the only country with a notified eIDAS eID. Denmark accepted incoming eIDs. Today, Portugal, Spain Germany, Czech republic, Belgium, Estonia, Netherlands, Latvia, Denmark, Slovakia, Denmark, Italy, Luxemburg and UK have notified their EIDs (Europa.eu, 2019). Hence, currently Business registration systems in these countries, if connected can be accessed using eIDAS. However, for the eIDAs to be used for Business registration, the cross-border business registration service it must enable identification and transaction. DIGINNO partners in consultation with personnel from eIDAs service providers, digitization agencies in the Nordic-Baltic region has come up with a solution. An aspect of the solution is presented in this paper.

5. PROPOSED SOLUTION

5.1. Technical description of the Service

The proposed solution is an intelligent central broker that interconnects the applicant, the national eID gateway (using eIDAS) and the national business registrar. The interface between the central broker and the national business registrar is interconnected using an API.

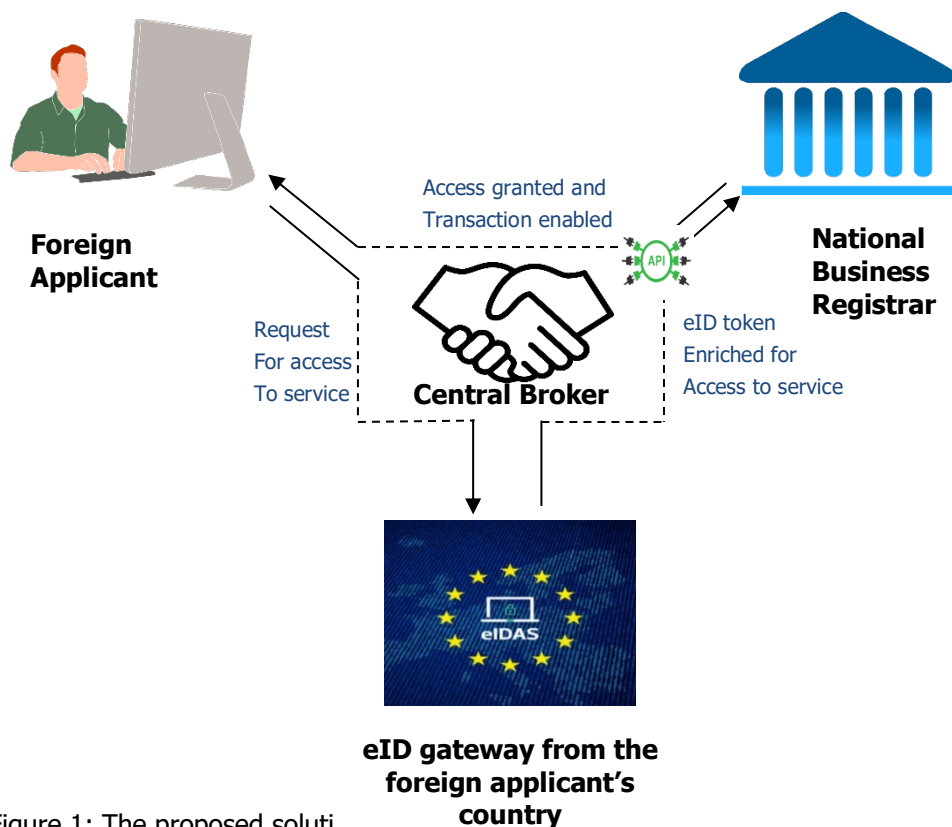

Figure 1: The proposed solution

Source (DIGINNO, 2019)

The eIDAS gateway: The eIDAS gateways in each member state is used for the identification and verification of natural persons and the legal persons they represent. The national eIDAS gateways also supplies the attributes needed to access the service as well as perform transactions. As mentioned earlier, the eIDAS

gateways does not enable transactions. How the proposed solution enables transaction is discussed later when describing how the central broker functions.

The central broker: This is an Intelligent or AI driven middleware consisting of two technologies. The first technology is a context broker that can intelligently extract and cache business registration information from each member state in the required language by the applicant as shown in the figure 2.

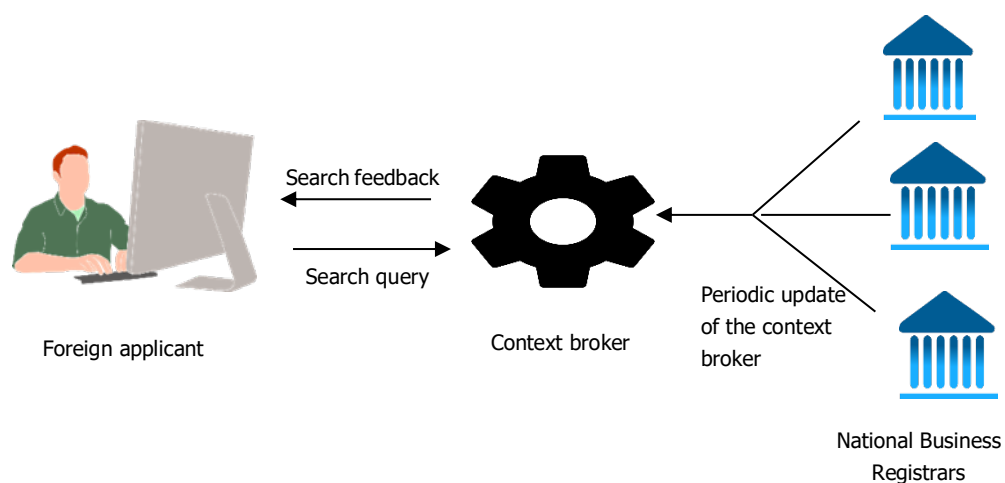

Figure 2: The context broker

Source (DIGINNO, 2019)

In situations where such language is not available, then the information will be provided in English. DIGINNO partners were against machine translation due to the challenges posed by the decontextualization of the translated words and wrong translations. Hence, the proposal was that member states at the minimum translate their service website into English, the national lingua franca and the language of a country where there is volume in the request to register businesses. Manual translation was proposed in the translation of national business registration portals. Nevertheless, the web page translation occurs when the applicant conducts a search. The applicant does not need to login in order to conduct a search, hence the eIDAS log in is not utilized for this function.

However as expressed in the figure 2, the use of cached data is proposed in order to reduce the burden of computation on the context broker. This implies that

periodically the context broker will retrieve information from national business registration systems to ensure that the information hosted is up to date.

The second technology is the message broker. The message broker receives incoming message from the applicant and then decides to which recipient (in this case business registrar) where the message should be sent.

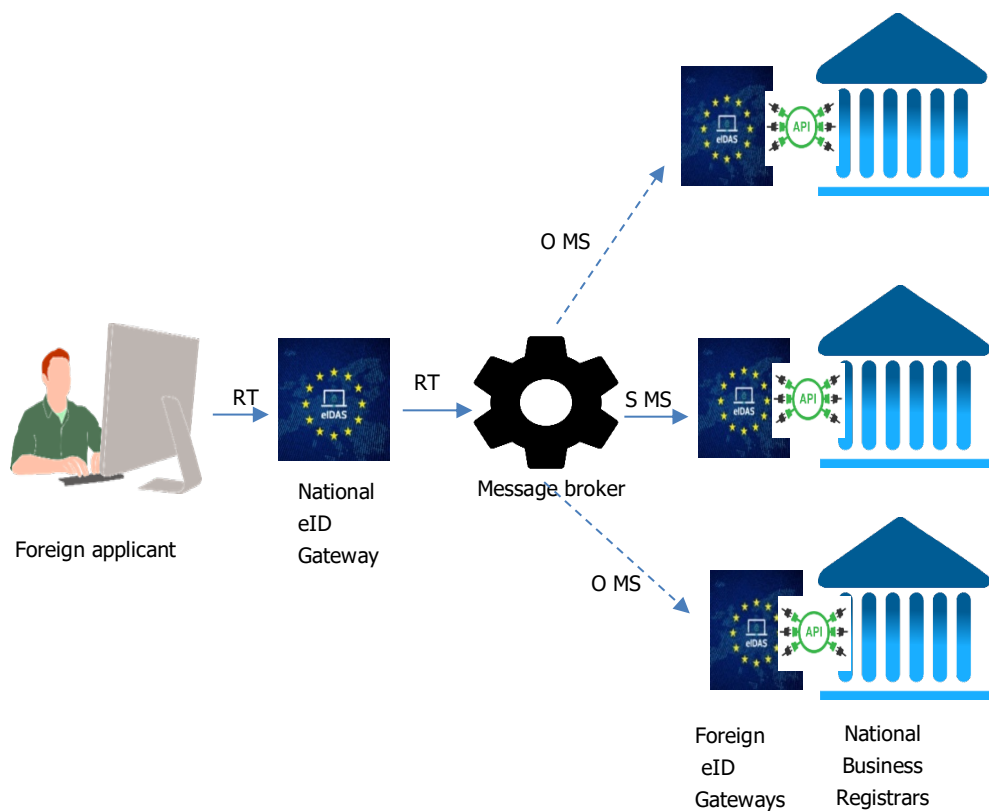

R T= Request for transaction

S MS= member state selected by the applicant

O MS = Other potential member state that could have been selected by Applicant.

Figure 3: The Message Broker

Source: (DIGINNO, 2019)

5.2. The transaction process using the Message broker

At the first stage, let's assume the applicant is Finnish and lives in Finland and wants to register his or her business in Spain. The applicant logs into the message broker using the Finnish eID via eIDAS. The mandatory attributes for natural and legal persons are used to access the message broker.

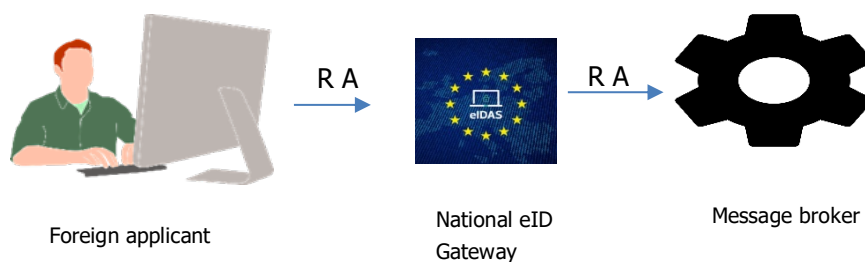

R A= Request for Access using eIDAS

Figure 4: Request for access by applicant

The applicant then selects Spain as the country of interest. Once selected, the message broker establishes a line of communication between the Finnish applicant and the Spanish business registration system via the Spanish eIDAS gateway. The Spanish eIDAS gateway responds by sending a message to the Finnish eIDAS gateway requesting optional attributes that will be sufficient for the Finnish applicant to perform a transaction as if the Finnish applicant were Spanish resident.

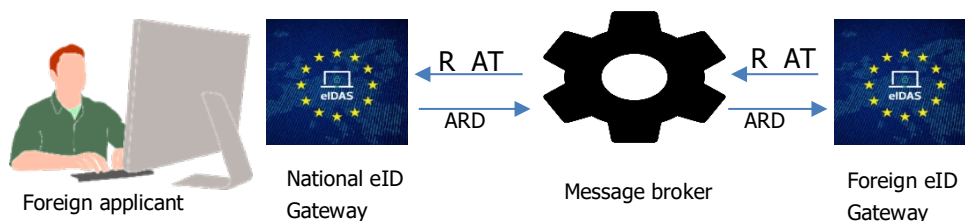

R AT = Request for additional attributes
 ARD = Attribute Requested Delivered

Figure 5: Request for optional attributes from the foreign eID gateway

The Finnish eIDAS gateway further enriches the token and responds in the affirmative to the Spanish eIDAS gateway. This affirmative response grants the Finnish applicant with the right to fill the relevant forms. At this point, the original request sent by the Finnish applicant is finally delivered to the API at the interface between the message broker and the Spanish business registration system.

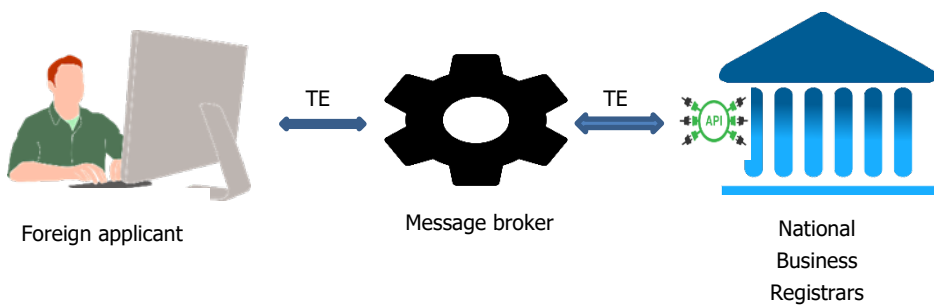

TE= Transaction enabled

Figure 6: Transaction process established

The API calls the relevant forms needed to register businesses in Spanish via the message broker to the e-Service website that serves as a graphical interface to the message broker.

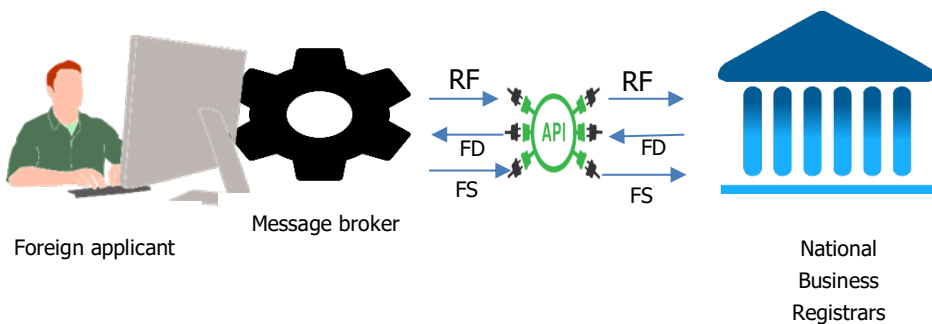

RF = Request form

FD= Forms delivered

FS = Forms submitted

Figure 6: Transaction process via the API

The applicant fills the necessary forms, uploads the necessary payment, make the necessary registration payments and clicks the submit button. On click of the submit button, message is sent via the message broker to the Spanish business registration system that the forms are ready to be submitted. The API responds on its readiness to receive and submit the forms. The forms are sent and submitted for processing.

Transactions that are not complete in one day can be delayed for not more than 5 days. After 5 days, the session is deleted from the Finnish applicants account in the message broker. In the case of a delayed session, the log in process will still follow the same process. However, the process will be different if the Spanish eID gateway as an example decides to store the attributes of the Finnish applicant.

The proposed solution introduces new dynamics to eIDAS such as attribute gateways, which does not exist at the moment. However part of the aim of the project is to propose technical solutions on how existing technical E-government solutions can be enhanced.

Nevertheless, with this technical solution persons in different EU countries can register their business in other EU countries without having to travel to the other country.

5.3. Proposed Organizational description of Service

The Build-Design-Operate (BDO) Public Private Partnership (PPP) model is proposed as a means of financing, management and the operation of the central Broker. In this model, the proposed infrastructure owners are the European Business Registrars Association. They were proposed, not just because they are business registrars, rather because the infrastructure will be owned collectively by EU member states. The proposed financing mechanism is via the Connecting Europe Facility funds or funds that will replace the current horizon 2020 funding

mechanism. The infrastructure will be Build-Designed and Operated by a private sector entity for an agreed period of time to be decided upon by the European Business Registrars Association. Funding for the private company operating the infrastructure could be either from agreed upon percentage of business registration fees paid by applicants in each EU member states. This organizational set-up is based on the premise that there will be an increase in cross-border business registration

6 DISCUSSION

The proposed technical and organizational framework highlights the evolution in how e-government service delivery. The focus on the studies in classical e-government literature has been on national centric (supply driven approach) approaches to the delivery of e-government infrastructure and services. Such national centric approaches could be e-government services delivered in silos (See example (Bannister & Connolly, 2012)), horizontally via a one-stop shop (see example (Kawashita, Baptista, & Soares, 2020)), via government-centric service delivery approach or via citizen-centric e-government service delivery approach (see example (Golden, Hughes, & Scott, 2003)) (Sharma & Rathore, 2020). These national centric approaches are driven by the public agenda to digitize e-government service delivery. However, in recent times in the EU, the evolution of e-government policies and laws and the need to facilitate the Digital Single Market has given rise to the need for cross-border service delivery. Just as in the case of previous national centric approaches, the initial approach by cross-border service delivery was driven by public agenda. Immigrant essential services such as business registration, immigration services, custom services etc. were services that should be delivered digitally across border. However today, the freedom of goods and services in the EU has opened up the possibility for a citizen (demand driven) approach to the delivery of e-government services. This became the basis for the e-government services developed in DIGINNO. It is also the reason the EU pushed for the use of digital tools in the implementation business registration services (EUR Lex, 2017).

The framework also highlights the continuous usefulness of PPP in the delivery of e-Government services. The use of Public Private Partnership today is not so much as a result of its usefulness in previous e-government projects. Rather it is because the e-government ecosystem has evolved from the government alone delivering the

services to an active Public-Private Partnership in the delivery of e-government services. An example can be seen in the delivery of eIDs, e-receipt and digital mail services where private enterprises deliver the service and government agencies utilize the services to deliver e-government services. Furthermore, the PPP in the delivery of e-government services has been strengthened via EU projects, such as Horizon 2020, Interreg projects and other relevant EU projects. This enabled interactions between public and private entities from different countries resulting in new cross border e-government services. An example is the STORK 1 and STORK 2 projects which has resulted in eIDAS. These partnerships has exposed the competencies of private entities in supporting e-government service delivery. It is based on this idea that DIGINNO partners opted for a PPP in the delivery of the proposed service.

The proposed framework has policy implications to the implementation of national company policy laws. National company policy laws were not designed for IT driven environments. However, the EU regulation on the digitization is less easy to implement at the national level. This is because from the 1990s countries in the EU have been digitizing their government service infrastructures. It was easy to develop such infrastructure to support existing national e-government processes. However facilitating cross-border business registration implies interconnecting cross-border business registration infrastructure. The proposed technical framework partially provides an answer to technical, semantic and operational interoperability; however, it does not provide a solution for legal interoperability. That in itself becomes a bottleneck, which requires modification of national company laws. However, in DIGINNO, inspiration was borrowed from Estonia on how to solve the problem. In the Estonian E-residency programme, the e-residents are not legal residents in Estonia. Those starting business under the scheme do so remotely. Estonia established local service providers that would assist as representatives for requirements that require residency. They have also shifted pre-registration processes to after registration processes. Hence they do not do away with their national business registration laws. Hence, in order to deal with the upcoming legal barrier, the recommendation from the DIGINNO project is to enact regulations that reshuffles the process. One reason for not requesting the elimination of national requirements is because there are national, economic, cultural and operational reasons why those processes are required. Hence reshuffling them to fit the process flow of the proposed infrastructure preserves the process and well and enable the member state to derive value from the infrastructure.

There are also human, cost and technology related risks associated with the presented solution. These risks include:

- **Resistance to change:** Business registrars already own their independent business registration systems. They might feel that too much investment is needed to implement and manage the system and hence find no need for the service. Solving this challenge will require change management solutions coordinated at the EU level and at the national levels. In some cases, funding incentives might be necessary. One possibility for such funding incentive is via the connecting Europe Facility (CEF). Aside funding, change management will also require bilateral collaborations. These bilateral collaborations could be aimed at producing test cases or pilots as way of convincing other Business registrars in the EU about the value of the solution. If this approach is adopted, the feasibility of change management resulting in a success is high. Aside business registrars, the critical component of the proposed framework is the availability of the attribute gateway. EID providers might have the incentive to develop the attribute gateways if cross-border service providers request for it. The absence of such a gateway will actually kill the transaction bit of the service.
- **Cost related barrier:** The cost of the development and integration of this infrastructure to the national business registrars is uncertain. This uncertainty poses a risk. This is because the cost of connecting different national eID infrastructure to the various Business registration system will vary per country. To mitigate this risk, this paper proposes a PPP framework led that the Association of European Business registrars. The details of the PPP are discussed in the next section.
- **Barrier of substitute technology:** We live in the world of rapid advancement in technology. Although the proposed technology is an intelligent system, other intelligent systems could emerge. That could become a barrier to the implementation of this solution as the relevant stakeholders would opt for the new technology, especially if it is cheaper to deploy.

Nevertheless, despite these risks, the success in the adoption of the proposed solution relies a great deal on who will own the infrastructure. The DIGINNO team

proposes the European Business Registrars Association. This is because the solution will support their desire to facilitate cross border business registration services.

7. CONCLUSION

This paper has provided an insight into the technical and organizational framework for using eIDAS to facilitate cross-border business registration services. It has also provided a discussion on the implication of such an e-government service to the study of e-government, the use of PPP in e-government service delivery and the implication of such services to existing national laws.

References

- Andersen, K. V., & Henriksen, H. Z. (2006). E-government maturity models: Extension of the. *Government Information Quarterly*(23), s. 236 – 248.
- Bannister, F., & Connolly, R. (2015). The great theory hunt: Does e-government really have a problem? *Government Information Quarterly*, 32(1), s. 1-11.
- Bannister, F., & Connolly, R. (2012). Forward to the Past: Lessons for the Future of E-government from the Story so Far. *Information Polity*, 17(3,4), 211 – 226.
- CEF Digital. (27. September 2019). *eIDAS SAML Attributes Profile V1.2 Final*. Hentet fra eIDAS eID Profile: <https://ec.europa.eu/cefdigital/wiki/display/CEFDIGITAL/eIDAS+eID+Profile?preview=/82773108/148898847/eIDAS%20SAML%20Attribute%20Profile%20v1.2%20Final.pdf>
- CIVITTA. (2018). *Business needs assessment of G2B cross-border services usage*. Riga: CIVITTA/DIGINNO.

- CIVITTA. (2018). *The research report of G2B cross-border services at national level*. Riga: CITTA/DIGINNO.
- Commission, E. (2018). *eGovernment in the European Union 2018*. European Commission.
- DG Just. (5. February 2018). *Assessment and quantification of drivers, problems and impacts related to cross-border transfers of registered offices and cross-border divisions of companies*. Hentet fra ec.europa.eu: https://ec.europa.eu/info/sites/info/files/dg_just_transfers_divisions_final_report_05022018_clean_1.pdf
- DIGINNO. (2019). *Feasibility Study on Cross-Border Business Registration using eIDAS*. DIGINNO.
- DIGINNO. (2019). *Feasibility Study on Cross-Border Business Registration using EIDAS*. DIGINNO Project Report.
- Ersoz, S., & Askeroglu, E. D. (2020). Generations X, Y, Z and their Perception of E-Government. *Online Journal of Communication and Media Technologies*, 10(1).
- EU parliament. (17. May 2017). *European Parliament resolution of 16 May 2017 on the EU eGovernment Action Plan 2016-2020 (2016/2273(INI))*. Hentet fra European Parliament: https://www.europarl.europa.eu/doceo/document/TA-8-2017-0205_EN.html?redirect
- EUR LEX. (25. 07 1985). *Council Regulation (EEC) No 2137/85 of 25 July 1985 on the European Economic Interest Grouping (EEIG)*. Hentet fra EUR Lex-Access to European Union Law: <https://eur-lex.europa.eu/legal-content/EN/ALL/?uri=CELEX%3A31985R2137>
- EUR -Lex. (8. October 2001). *COUNCIL REGULATION (EC) No 2157/2001*. Hentet fra EUR-LEX: <https://eur-lex.europa.eu/legal-content/EN/TXT/PDF/?uri=CELEX:32001R2157&qid=1538743067623&from=EN>
- EUR Lex. (09. 04 2014). *Proposal for a DIRECTIVE OF THE EUROPEAN PARLIAMENT AND OF THE COUNCIL on single-member private limited liability companies*. Hentet fra EUR Lex Accessing European Union Law: <https://eur-lex.europa.eu/legal-content/EN/ALL/?uri=CELEX:52014PC0212>

EUR Lex. (30. 6 2017). *Directive (EU) 2017/1132 of the European Parliament and of the Council of 14 June 2017 relating to certain aspects of company law (Text with EEA relevance.)*. Hentet fra EUR Lex Access to European Union Law: <https://eur-lex.europa.eu/legal-content/EN/TXT/?uri=CELEX%3A32017L1132>

EUR-Lex. (24. 12 2002). *EUR Lex - Access to european Union Law*. Hentet fra Treaty establishing the European Community (Consolidated version 2002): <https://eur-lex.europa.eu/legal-content/EN/TXT/?uri=CELEX%3A12002E%2FTXT>

EUR-Lex. (26. 10 2012). *Consolidated version of the Treaty on the Functioning of the European Union*. Hentet fra EUR-Lex : Access to the European Union law: <https://eur-lex.europa.eu/legal-content/EN/TXT/?uri=celex%3A12012E%2FTXT>

Europa.eu. (2019). *Overview of pre-notified and notified eID schemes under eIDAS*. Hentet fra EID User Community: <https://ec.europa.eu/cefdigital/wiki/display/EIDCOMMUNITY/Overview+of+pre-notified+and+notified+eID+schemes+under+eIDAS?replyToComment=62885725&#comment-62885725>

EUROPEAN COMMISSION. (2016). *EU eGovernment Action Plan 2016-2020 COM(2016) 179 final*. Brussels: EUROPEAN COMMISSION.

European Commission. (2017). *eGovernment Benchmark 2017 Taking stock of user-centric design and delivery of digital public services in Europe*. Brussel: European Commission.

European Parliament and the Council. (2014). *Regulation (EU) No 910/2014 of the European Parliament and of the Council of 23 July 2014 on electronic identification and trust services for electronic transactions in the internal market and repealing Directive 1999/93/EC*. Brussels: European Commission.

Eurostat. (28. January 2020). *Business demography statistics*. Hentet fra Eurostat: https://ec.europa.eu/eurostat/statistics-explained/index.php/Business_demography_statistics

- Falch, M., Williams, I., & Tadayoni, R. (1 2018). Cross-border e-Government Services in the Baltic Sea Region—Status and Barriers. *Nordic and Baltic Journal of Information and Communications Technologies*, s. 83-100.
- Ghareeb, A. M., Darwish, N. R., & Hefny, H. A. (2020). Proposed Approach for Enhancing Adoption of E-Government Services Using AHP and PROMETHEE. *International Journal of E-Services and Mobile Applications (IJESMA)*, 12(3), 38-59.
- Golden, W., Hughes, M., & Scott, M. (2003). The Role of Process Evolution in Achieving Citizen Centered E-Government. *Americas Conference on Information Systems 2003 Proceedings*. AMCIS.
- Grönlund, Å. (2010). Ten years of e-government: The 'end of history' and new beginning. I *In International Conference on Electronic Government* (s. 13-24). Berlin, Heidelberg: Springer.
- Karen Laynea, J. L. (2001). Developing fully functional E-government: A four stage. *Government Information Quarterly*(18), s. 122–136.
- Kawashita, I. M., Baptista, A. A., & Soares, D. S. (22. April 2020). E-government maturity models: more of the same. <http://repositorium.sdum.uminho.pt/>.
- Lee, J. (2010). 10 year retrospect on stage models of e-Government: A qualitative meta-synthesis. *Government Information Quarterly*, 27(3), s. 220-230.
- Linden, N. v., & al, e. (2019). *eGovernment Benchmark 2019*. European Commission.
- Müller, S. D., & Skau, S. A. (2015). Success factors influencing implementation of e-government at different stages of maturity: a literature review. *International Journal of Electronic Governance*, 7(2), s. 136-170.
- Sharma , P. K., & Rathore, V. S. (2020). Performance Analysis of E-Governance Citizen-Centric Services Through E-Mitra. I M. Pant , T. Sharma , S. Basterrech , & C. Banerjee, *Performance Management of Integrated Systems and its Applications in Software Engineering. Asset Analytics (Performance and Safety Management)* (s. 175-182). Singapore: Springer.
- (2017). *Tallinn Declaration on eGovernment*. Tallin.

- Williams , I. (2020). E-Government, Yesterday, Today and in the Future. I A. Sieben, *E-Government: Perspectives, Challenges and Opportunities*. Hauppauge: Nova Publishers.
- Williams, I., Falch, M., & Tadayoni, R. (2018). Internationalization of e-Government Services. *11th CMI International Conference: Prospects and Challenges Towards Developing a Digital Economy within the EU, 29–30 NOVEMBER 2018* (s. 19-31). Copenhagen Denmark: IEEE.