

Blin, Jean-Marie; Ramakrishan, Ram. T.S.

**Working Paper**

## The Geometry of Preference Aggregation and Domain Restrictions

Discussion Paper, No. 372

**Provided in Cooperation with:**

Kellogg School of Management - Center for Mathematical Studies in Economics and Management Science, Northwestern University

*Suggested Citation:* Blin, Jean-Marie; Ramakrishan, Ram. T.S. (1979) : The Geometry of Preference Aggregation and Domain Restrictions, Discussion Paper, No. 372, Northwestern University, Kellogg School of Management, Center for Mathematical Studies in Economics and Management Science, Evanston, IL

This Version is available at:

<https://hdl.handle.net/10419/220732>

**Standard-Nutzungsbedingungen:**

Die Dokumente auf EconStor dürfen zu eigenen wissenschaftlichen Zwecken und zum Privatgebrauch gespeichert und kopiert werden.

Sie dürfen die Dokumente nicht für öffentliche oder kommerzielle Zwecke vervielfältigen, öffentlich ausstellen, öffentlich zugänglich machen, vertreiben oder anderweitig nutzen.

Sofern die Verfasser die Dokumente unter Open-Content-Lizenzen (insbesondere CC-Lizenzen) zur Verfügung gestellt haben sollten, gelten abweichend von diesen Nutzungsbedingungen die in der dort genannten Lizenz gewährten Nutzungsrechte.

**Terms of use:**

*Documents in EconStor may be saved and copied for your personal and scholarly purposes.*

*You are not to copy documents for public or commercial purposes, to exhibit the documents publicly, to make them publicly available on the internet, or to distribute or otherwise use the documents in public.*

*If the documents have been made available under an Open Content Licence (especially Creative Commons Licences), you may exercise further usage rights as specified in the indicated licence.*

Discussion Paper No. 372

THE GEOMETRY OF PREFERENCE

AGGREGATION AND DOMAIN RESTRICTIONS

J.-M. Blin and Ram. T.S. Ramakrishnan

Graduate School of Management  
Northwestern University  
Evanston, Illinois 60201

March, 1979

## I. Introduction

To state a preference is to state a relation over pairs of alternatives. Normally such a relation over a pair of choices is exclusive--if I prefer tea over coffee today the reverse cannot also hold. It may be consistent over three choices--if I prefer wine to beer and beer to water it seems consistent that I prefer wine to water also. It may also be complete--if I am willing to state this relation for all pairs of alternatives. But formally further distinctions are required. I may be indifferent between tea, with no sugar and tea with almost no sugar; and indifferent between tea with almost no sugar and tea with some sugar but still prefer no sugar to some. Similarly preferring A to B and B to C may only mean that I definitely do not prefer C to A.-- I may be indifferent between the two. Whether such preferences 'make sense' depends often on what the alternatives are. These notions apply equally to individuals or to groups. But if a group decision is to be explained by its members preferences, we may have to relax what is meant by a preference. As the voting paradox shows, transitive individual preference does not preclude intransitive group preferences--unless some restrictions are placed on admissible individual preferences as Black [2], Inada [12], Pattanaik [18], Sen [25] and others have shown. This is usually demonstrated by reference to logical arguments over the binary relations representing these preferences. These arguments, however, are of little help in explaining how such domain restrictions operate and in suggesting how to construct all such restrictions for a given set of permissible preferences .

This paper develops a simple geometric construction to explain the occurrence of cyclical group preferences. The value of this method is that

it yields a general procedure to define domain restrictions on individual preferences guaranteeing noncyclical group preferences under majority voting. This is illustrated with known as well as new domain restrictions for various classes of individual preferences. Specifically, we use the lattice structure of binary aggregation procedures over the unit cube. This structure allows us to unify and extend these conditions. Section 2 states the definitions and model we use. Section 3 contains a derivation of the basic rule for avoiding cyclical outcomes via domain restrictions. In Section 4, this rule is successively applied to transitive, quasi-transitive and weakly acyclic individual and group preferences. Another set of conditions for noncyclical outcomes using the distribution of voters on orderings is discussed (e.g., Saposnik [21], Gaertner and Heinricke [8]) in Section 5. Finally, concluding remarks on the strength of these various conditions are made.

## 2. Model Formulation

### A. Definitions

Let  $S = \{x, y, z, \dots\}$  stand for the finite set of  $m$  alternatives under consideration. A binary relation  $T$  on  $S$  is a set of ordered pairs  $\{(x, y), (x, z), \dots\}$  i.e.,  $T \subseteq S \times S$ . Individual and group preferences can display various properties. In particular we say that  $T$  is:

$$(2.1) \text{ Reflexive } \Leftrightarrow xTx \quad \forall x \in S$$

$$(2.2) \text{ Complete (or connected) } \Leftrightarrow xTy \text{ or } yTx \quad \forall x, y \in S$$

(or nonexclusive)

$$(2.3) \text{ Symmetric } \Leftrightarrow xTy \Rightarrow yTx \quad \forall x, y \in S$$

$$(2.4) \quad \text{Asymmetric} \Leftrightarrow xTy \Rightarrow \sim yTx \quad \forall x, y \in S$$

( $\sim$  means not)

We use 3 types of binary relations: P which is irreflexive and asymmetric; I which is symmetric and reflexive; and R which is P or I. R is taken to be complete. Let T denote any binary relation defined through P and I, and J denote the set of all such relations. Let the society consist of voters  $i = 1, \dots, n$  from the set V.

An aggregation rule f is a relation that specifies one binary relation for each set of individual preference relations; namely,

$$T = f(T_1, \dots, T_n)$$

where T is binary relation P or I and  $T_1, \dots, T_n$  are the binary relation of n individuals on S. A rule is binary if and only if for two sets individual relations  $\{T_1, \dots, T_n\}$  and  $\{T'_1, \dots, T'_n\}$  on S and for any two x and y belonging to S:

$$(2.5) \quad [(\forall i)\{(xP_i y \Leftrightarrow xP'_i y) \text{ and } (xI_i y \Leftrightarrow xI'_i y)\} \Rightarrow \\ (xPy \Leftrightarrow xP'y) \text{ and } (xIy \Leftrightarrow xI'y)]$$

In this paper we are concerned only with binary choice rules. This restriction amounts to imposing the Independence of Irrelevant Alternatives condition on pairs (Arrow [1]).

A binary relation T on S is transitive (t) if and only if

$$(2.6) \quad [(xRy \text{ and } yRz) \Rightarrow xRz] \quad \forall x, y, z \in S$$

A binary relation on S is quasi-transitive (q.t.) over S if and only if

$$(2.7) \quad [(xPy) \text{ and } (yPz) \Rightarrow xPz] \quad \forall x, y, z \in S$$

A binary relation on a triple is weakly acyclic (w.a) if and only if

$$(2.8) \quad [(xPy) \text{ and } (yPz) \rightarrow \sim(zPx)] \quad \forall x,y,z \in S$$

A binary relation on a triple is cyclic if and only if it is not weakly acyclic.

Domain restrictions are normally stated on triples of alternatives (Sen and Pattanaik [27]). If we take S as containing 3 alternatives {x,y,z} we obtain 27 relations: one of the three binary relations P, I or  $\sim R$  on the 3 pairs =  $3^3$ . They are:

(i) Transitive preferences:

- |            |            |            |
|------------|------------|------------|
| (1) xPyPz  | (2) yPzPx  | (3) zPxPy  |
| (4) xPzPy  | (5) zPyPx  | (6) yPxPz  |
| (7) xIyPz  | (8) yIzPx  | (9) zIxPy  |
| (10) xPyIz | (11) yPzIx | (12) zPxIy |
| (13) xIyIz |            |            |

(ii) Quasitransitive preferences:

- |              |              |              |
|--------------|--------------|--------------|
| (14) zIxPyIz | (15) zIyPxIz | (16) yIxPzIy |
| (17) yIzPxIy | (18) xIyPzIx | (19) xIzPyIx |

(iii) Weakly acyclic preferences:

- |              |              |              |
|--------------|--------------|--------------|
| (20) xPyPzIx | (21) xPzPyIx | (22) yPxPzIy |
| (23) yPzPxIy | (24) zPxPyIz | (25) zPyPxIz |

(iv) Cyclic preferences:

- |              |              |
|--------------|--------------|
| (26) xPyPzPx | (27) xPzPyPx |
|--------------|--------------|

For future reference we define the following sets for the three alternative case:

- (2.10) TR = set of transitive relations ((1) to (13)).
- TS = set of transitive relations with strict preferences only ((1) to (6)) (strong order).
- TW = set of transitive relations with only one indifference ((7) to (12)) (weak order).
- UC = the relation  $xIyIz$  (13) (unconcerned).
- TI = quasitransitive but not transitive relations ((14) to (19)) (two indifferences).
- AC = weakly acyclic but not quasitransitive relations ((20) to (25)) (two preferences).
- CY = cyclic preferences ((26) and (27)).
- QT = (TR)  $\cup$  (TI) quasitransitive relations ((1) to (19)).
- WA = (QT)  $\cup$  (TP) weakly acyclic relations ((1) to (25)).
- J = (TS)  $\cup$  (TW)  $\cup$  (UC)  $\cup$  (TI)  $\cup$  (AC)  $\cup$  (CY) ((1) to (27)).
- SP = strict preference relations (TS)  $\cup$  (CY)
- TP = (TW)  $\cup$  (AC) (two preferences). Also,
- J = (SP)  $\cup$  (TP)  $\cup$  (TI)  $\cup$  (UC)

### B. Majority Voting Rule

For geometric convenience we represent each individual preference over  $S$  as a vector  $D \in \mathbb{R}^k$  where  $k = \frac{m(m-1)}{2}$ . The  $h$ th component of  $D$ ,  $D^h$  corresponds to a fixed ordered pair and the subscript  $i$  corresponds to the individual  $i$ .

$$(2.11) \quad D_i^h = D_i^{xy} \quad \left\{ \begin{array}{l} 0 \Leftrightarrow yP_i x \\ 1/2 \Leftrightarrow xI_i y \\ 1 \Leftrightarrow xP_i y \end{array} \right.$$

So given any binary relation and fixed sequence of ordered pairs of alternatives we can form the  $D_i$  vector for this relation. Let  $E$  be defined as the set of all possible  $D_i$ 's

$$E = \{D \mid D \in \mathbb{R}^3, D^h \in \{0, 1/2, 1\}\}$$

Then we can define the function  $G: T \rightarrow E$ , so that given a binary relation  $T_i$ , a  $D_i$  vector in  $E$  based on a sequence of ordered pairs is obtained,  $D_i = G(T_i)$ . Similarly let  $H$  be the inverse function of  $G$ , i.e. given a  $D_i$  vector, we can form the binary relation  $T_i$  corresponding to it, i.e.  $H: E \rightarrow J, T_i = H(D_i)$ .

In this framework aggregation rules can be written as

$$D = f(D_1, D_2, \dots, D_i, \dots, D_n)$$

A binary rule is separable in the sense that

$$D^{xy} = f^{xy}(D_1^{xy}, \dots, D_n^{xy})$$

Letting  $U = \{0, 1/2, 1\}$ , we now impose four conditions on  $f$  for every  $(x, y)$  pair.

(I) (Decisiveness):  $f^{xy}$  is defined and single valued for every element of  $U \times U \times \dots \times U$  for all  $x$  and  $y$  in  $S$ .

(II) (Neutrality):  $f^{xy}(1 - D_1^{xy}, \dots, 1 - D_n^{xy}) = 1 - f^{xy}(D_1^{xy}, \dots, D_n^{xy})$ .

(III) (Anonymity):  $f$  is symmetric in its arguments.

(IV) (Positive Responsiveness): If  $D^{xy} = f(D_1^{xy}, \dots, D_n^{xy}) = \frac{1}{2}$  or 1 and  $D_i^{xy} = D_i'^{xy}$  for  $i \neq j$  and  $D_j'^{xy} > D_j^{xy}$  then  $f(D_1'^{xy}, \dots, D_n'^{xy}) = 1$ .



Let us define  $\bar{D}^{xy}$  as

$$(2.12) \quad \bar{D}^{xy} = (\sum_i D_i^{xy})/n$$

May [14] has shown that these conditions completely characterize majority voting. Majority voting can then be defined as

$$(2.13) \quad D^{xy} = \begin{cases} 1 & \text{iff } \bar{D}^{xy} > 1/2 \\ 1/2 & \text{iff } \bar{D}^{xy} = 1/2 \\ 0 & \text{iff } \bar{D}^{xy} < 1/2 \end{cases} \quad \forall x, y \in S$$

Let us denote by  $\text{Maj}(\{T_i\}) = T^* \in J$  as the majority outcome binary relation and  $\text{Maj}(\{D_i\}) = D^*$  as the corresponding D vector, i.e.  $D^* = G(T^*)$ . We also denote by  $\text{Maj}(\bar{D})$  the vector of group preferences obtained from  $\bar{D}$ .

Pairwise majority voting is independent of the number of alternatives; but, of course, it can lead to a cyclical group preference for more than two alternatives. To avoid such cycles, domain restrictions on allowed individual preferences have been derived by Sen [23], Sen and Pattanaik [27], Inada [12]. They have derived necessary and sufficient conditions on the list of individual preferences that could be allowed to guarantee an acyclic social preference under majority voting. The requirements are on every triple of alternatives and if those conditions are satisfied the social outcome on m alternative is also acyclic. So hereafter we consider only triples. This makes a clear geometrical representation possible.

### III. General Characterization of Domain Restrictions for Majority Voting

#### A. Geometry of Binary Relations for Three Alternatives:

As we saw earlier there are 27 binary relations on 3 alternatives  $\{x,y,z\}$ . We can characterize them by a three-dimensional vector, with each component corresponding to an ordered pair:  $(x,y)$ ,  $(y,z)$  and  $(z,x)$ . So a typical relation, say #16  $(xIy, yPz, zIx)$ , is represented by the  $D_i$  vector  $(\frac{1}{2}, 1, \frac{1}{2})$ .

An obvious way of representing these relations in a lattice is to use the unit three-dimensional cube as shown in Figure 1. The strict preference orderings are the vertices (extreme points).

Figure 1

The center of the cube is the point of complete indifference,  $xIyIz$ . With our cyclic labelling of the arcs  $(x,y)$ ,  $(y,z)$  and  $(z,x)$ , the two cyclic relations are the two ends points of the main diagonal from the origin. Transitive relations with indifferences are on edges joining transitive vertices. Quasitransitive (but not transitive) relations are on the center of the six planes bounding the cube. Weakly acyclic but not quasitransitive preferences are on edges leading from cyclic preferences. With  $m$  alternatives there are  $2^k$  vertices ( $k = m(m-1)/2$ ).

#### B. Geometry of Aggregation

Since we are concerned with binary choice rules only, the aggregation problem can be defined on our lattice. Each individual picks one point from the allowed set of points which itself is a subset of  $J$ . That is, a domain  $B$ , that is to be allowed is fixed with  $B \subseteq J$ ; equivalently, the  $D_i$ 's corresponding to the  $T_i$ 's are fixed in, say,  $C \subseteq E$ . Aggregating the  $D_i$ 's means picking some point from  $E$ . Constrained aggregation restricts us to some proper subset of  $E$ --e.g. the transitive relations. As majority voting is defined by the mean  $\bar{D}$  of the  $D_i$ 's  $\in C$ ,  $\bar{D}$  lies in the convex hull (CV) of  $C$ :  $\bar{D} \in CV(C)$ .

Let  $d(a,b)$  denote the distance from point  $a$  to point  $b$ ,  $a,b \in \mathbb{R}^k$  as defined by the  $\ell$ -metric

$$(3.1) \quad d^\ell(a,b) = \left[ \sum_{i=1}^k |a^i - b^i|^\ell \right]^{1/\ell} \quad \text{where } \ell > 0$$

Then we can describe the majority voting as a "closest point rule".

Specifically:

$$(3.2) \quad f(\bar{D}) = D^* \text{ if } \exists D^* \in SP, \ni d(D^*, \bar{D}) < d(D, \bar{D}) \quad \forall D \in SP, D \neq D^*$$

If no such  $D^*$  exists then

$$(3.3) \quad f(\bar{D}) = D^*, \text{ if } \exists D^* \in TP, \ni d(D^*, \bar{D}) < d(D, \bar{D}) \quad \forall D \in TP, D \neq D^*$$

If no such  $D^*$  exists then

$$(3.4) \quad f(\bar{D}) = D^*, \text{ if } \exists D^* \in TI, \ni d(D^*, \bar{D}) < d(D, \bar{D}) \quad \forall D \in TI, D \neq D^*$$

If no such  $D^*$  exists then

$$(3.5) \quad \bar{D} = f(\bar{D}) = (\frac{1}{2}, \frac{1}{2}, \frac{1}{2}).$$

Theorem 1 allows us not to have to specify  $\ell$ . First, some notation:  $L$  be any set of integers  $i$ ,  $1 \leq i \leq k$  and  $|L| = h$  (cardinality of  $L=h$ ). Let  $W^h$  be the family of all such sets  $L$  of cardinality  $h$ , i.e.  $|L| = h$  if  $L \in W^h$ ;  $h$  can be zero in which case all  $L$ 's are empty. For a fixed  $h$  let  $\bar{U}^h = \{a \mid a^i = \frac{1}{2} \text{ if } i \in L \text{ and } a^i = 0 \text{ or } 1 \text{ if } i \notin L \text{ for some } L \in W^h\}$ , and  $U^h = \{a \mid a^i = \frac{1}{2} \text{ if } i \in L \text{ and } 0 \leq a^i \leq 1 \text{ if } i \notin L \text{ for some } L \in W^h\}$ . The following theorem states that the 'closest'  $a$  in  $\bar{U}^h$  to any  $u$  in  $U^h$  does not depend on the metric  $\ell$  we use

Theorem 1: Given  $h$  and  $u \in U^h$  if  $\exists \bar{a} \in \bar{U}^h \ni d^1(u, \bar{a}) < d^1(u, a)$  for all  $a \in \bar{U}^h$ ,  $a \neq \bar{a}$ , then  $d^\ell(u, \bar{a}) < d^\ell(u, a)$  for all  $a \in \bar{U}^h$ ,  $a \neq \bar{a}$ ,  $\ell > 1$ .

Proof: We note that all  $a \in \bar{U}^h$  have  $\frac{1}{2}$ 's in exactly  $h$  places.  $u \in U^h$  has at least  $h$   $\frac{1}{2}$ 's.

$$(i) \quad d^\ell(u, a) = \left[ \sum_{i=1}^k |u^i - a^i|^\ell \right]^{1/\ell}$$

(a) Suppose there are exactly  $h$   $\frac{1}{2}$ 's in  $u$ . The  $k$  terms of (i) are either  $u^i$  or  $|u^i - \frac{1}{2}|$  or  $1 - u^i$ . To form any  $a \in \bar{U}^h$  we have to put  $\frac{1}{2}$ 's in  $h$  places and 0's or 1's in the  $(k-h)$  places of  $a$ . From this observation we can form  $\bar{a}$  given  $u$  as

$$(ii) \quad \bar{a}^i = \begin{cases} \frac{1}{2} & \text{iff } u^i = \frac{1}{2} \\ 0 & \text{iff } u^i < \frac{1}{2} \\ 1 & \text{iff } u^i > \frac{1}{2} \end{cases} \quad i = 1, \dots, k$$

That is the  $\frac{1}{2}$ 's of  $\bar{a}^i$  and  $u^i$  match. We can easily show that  $\bar{a}^i$  of (ii) minimizes  $\sum_{i=1}^k |u^i - a^i|$ . Suppose  $\tilde{a} \neq \bar{a}$  was the closest  $a \in \bar{U}^k$ . Then  $\tilde{a}$  violates one of (ii).

Suppose  $\tilde{a}^i$  was not equal to  $\frac{1}{2}$  when  $u^i = \frac{1}{2}$ . So  $\tilde{a}^i = 1$  or  $0$ . As there are at least  $h$   $\frac{1}{2}$ 's in  $a$  and  $u \ \exists j \neq i \ni \tilde{a}^j = \frac{1}{2}$  and  $u^j \neq \frac{1}{2}$ . Let  $b \in U^h$  such that  $b^i = \frac{1}{2}$  and  $b^j = 1$  if  $u^j > \frac{1}{2}$  and  $b^j = 0$  if  $u^j < \frac{1}{2}$  and  $b^p = \tilde{a}^p$  for  $p \neq i, p \neq j$ . Then

$$d^1(b, u) = \sum_{\substack{p=1, p \neq i \\ p \neq j}}^k |b^p - u^p| + |b^i - u^i| + |b^j - u^j| = A + |b^j - u^j|$$

(denoting the first term by  $A$ )

$$d^1(\tilde{a}, u) = A + |\tilde{a}^i - \frac{1}{2}| + |\tilde{a}^j - u^j| = A + \frac{1}{2} + |\frac{1}{2} - u^j|$$

Now as  $|b^j - u^j| < \frac{1}{2}$ , by definition of  $b^j$ ,  $d^1(\tilde{a}, u) > d^1(b, u)$  contradicting  $\tilde{a}$  is minimum.

Similarly we can show that if  $\tilde{a}^i \neq 0$  if  $u^i < \frac{1}{2}$  or  $\tilde{a}^i \neq 1$  when  $u^i > \frac{1}{2}$ ,  $d^1(\tilde{a}, u)$  cannot be minimum. So  $\bar{a}$  from (ii) is the closest  $a \in \bar{U}^h$  from  $u$  for  $l=1$ .

We can also see that the numbers  $|\bar{a}^i - u^i|$  take the lowest possible values among  $|a^i - u^i|$ . If  $\tilde{a} \neq \bar{a}$  was closer, then as shown earlier, the ordered series of numbers  $|\bar{a}^i - u^i|$  will be less than the ordered series of numbers  $|\tilde{a}^i - u^i|$ . Therefore taking  $l$ th powers of  $|\bar{a}^i - u^i|$  and summation keeps  $d^l(\bar{a}, u)$  as smallest. So  $\bar{a}$  as defined in (ii) is the closest under any metric  $l$ .

(b) Suppose there are more than  $h \frac{1}{2}$ 's in  $u$ . Let there be just  $h+1 \frac{1}{2}$ 's. Pick an arbitrary  $p$  such that  $u^p = \frac{1}{2}$ . We can form two  $a \in \bar{U}^h$ ,  $a_1$  and  $a_2$  such that  $d(a_1, u) = d(a_2, u)$  and a minimum as in Theorem 1 will not exist. For  $i \neq p$  set  $a_1$  and  $a_2$  from (ii) equal. Set  $a_1^p = 1$  and  $a_2^p = 0$ . We easily see that  $d(a_1, u) = d(a_2, u)$ . So a minimum does not exist.  
Q.E.D.

In our notation  $\bar{U}^0 = SP$ ,  $\bar{U}^1 = TP$ ,  $\bar{U}^2 = TI$  and  $\bar{U}^3 = UC$ . So at any of the stages in (3.2) to (3.5), the minimum if it exists will not depend on the metric we use.

Informally this method can be described thus. It first picks the closest point to  $\bar{D}$  from the set  $SP$ .<sup>(1)</sup> A unique  $D \in SP$  will exist only if  $\bar{D}^i \neq \frac{1}{2}$  for  $i = 1, 2, 3$ . That is by (2.13) three preferences can be defined and the unique  $D^*$  will exist. We can view the unit cube as containing 8 cubes of side length  $\frac{1}{2}$ . Each of these cubes has one  $D \in SP$  only, associated with it.  $D^*$  exists in (3.2) only if  $\bar{D}$  is in the interior of  $D$  of one of those eight cubes, or in the interior of the planes of side length  $\frac{1}{2}$ , passing through it. More formally, we define the regions in the unit cube  $REG(D)$  for each  $D \in E$  such that if  $\bar{D}$  lies in  $REG(D)$ ,  $Maj(\bar{D}) = D$ . That is  $REG(D)$  is a point to set correspondence  $REG: E \rightarrow \mathbb{R}^3$ . A trivial example is  $D \in REG(D)$  as  $f(\bar{D}) = \bar{D}$  if  $\bar{D} \in E$ . For  $D \in SP$ ,  $REG(D) = \{a \mid \exists \lambda_1, \lambda_2, \lambda_3 \in \mathbb{R}, \lambda_1, \lambda_2, \lambda_3 \in (0, 1] \ni a^i = \lambda_1 D^i + (1 - \lambda_1) \frac{1}{2}, i = 1, 2, 3\}$ . That is  $REG(D)$  is the half cube excluding the planes of Figure 2, below.

Such a  $D^*$  will not exist if and only if  $\bar{D}$  lies on the three planes perpendicular to each other, parallel to the axes and going through  $(\frac{1}{2}, \frac{1}{2}, \frac{1}{2})$ .

---

<sup>1</sup>The sets  $SP$ ,  $TP$ , etc. have been defined for the binary relations in (2.10). To simplify we use the same symbols for the sets of  $D$  vectors representing these relations.

Figure 2

Only if  $\bar{D}$  lies on one or more of those planes (let us call the union of the three planes  $P^3$ ) will there be a tie as to which of the  $D \in SP$  is closest and this means  $\bar{D}$  has one  $\bar{D}^i = \frac{1}{2}$ .

If such a tie exists then majority voting yields indifference as outcome. Suppose there is only one indifference (i.e. only one  $\bar{D}^i$  is equal to  $\frac{1}{2}$ ). Then one of the TP points (two preferences and one indifference) is the outcome as given in (3.3). A unique point  $D^* \in TP$  (closest to  $\bar{D}$ ) will exist if there is only one indifference in which case (3.2) would have failed to find a point in  $SP$  as closest. This step will fail if and only if  $\bar{D}$  has more than one  $\bar{D}^i = \frac{1}{2}$ . That means  $\bar{D}$  lies on one of the three lines passing through  $\{\frac{1}{2}, \frac{1}{2}, \frac{1}{2}\}$ , perpendicular to each other, parallel to the axes. (See Figure 3). Formally,

If  $D \in TP$ , i.e.  $D^j \neq \frac{1}{2}$ ,  $D^k \neq \frac{1}{2}$  for  $j \neq k$ ,  $D^i = \frac{1}{2}$  for  $i \neq j$ ,  $i \neq k$

$$\text{REG}(D) = \{a \mid a^i = \frac{1}{2}, \exists \lambda_1, \lambda_2 \in \mathbb{R}, \lambda_1, \lambda_2 \in (0, 1], \exists$$

$$a^j = \lambda_1 D^j + (1 - \lambda_1) \frac{1}{2}, a^k = \lambda_2 D^k + (1 - \lambda_2) \frac{1}{2}\}$$

That is  $\text{REG}(D)$  is the plane in Figure 2 closest to  $D$  but excluding the lines shown in Figure 2.

Figure 3

We then consider (3.4). There, a  $D^* \in TI$  will fail to exist if and only if  $\bar{D} = (\frac{1}{2}, \frac{1}{2}, \frac{1}{2})$ . The closest point in  $TI$  will be chosen which is the same as obtained by majority voting with two indifferences. Formally,

If only one  $\bar{D}^j \neq \frac{1}{2}$ , for some  $j$ , i.e.  $D \in TI$

$$\text{REG}(D) = \{a \mid \exists \lambda \in \mathbb{R}, 0 < \lambda \leq 1, \exists a = \lambda D + (1 - \lambda) (\frac{1}{2}, \frac{1}{2}, \frac{1}{2})\}$$

That is  $\text{REG}(D)$  is the line from  $D$  to  $(\frac{1}{2}, \frac{1}{2}, \frac{1}{2})$  excluding the latter.

(See Figure 3).

If this step also fails, then  $f(D) = D^* = \bar{D} = (\frac{1}{2}, \frac{1}{2}, \frac{1}{2})$ . Formally,

$$\text{REG}(\frac{1}{2}, \frac{1}{2}, \frac{1}{2}) = (\frac{1}{2}, \frac{1}{2}, \frac{1}{2})$$

It is clear that by construction, our algorithm yields the same solution as majority voting.

Now if a set of points  $C \subseteq E$  is chosen as the domain (corresponding to  $B \subseteq J$ ) of permissible voter opinions,  $\bar{D}$  will necessarily lie in  $CV(C)$  the convex hull of  $C$ . From  $\bar{D}$  using (3.2) to (3.5) majority voting will pick a  $D^*$  as social choice. We apply this reasoning to characterize domain restrictions guaranteeing acceptable outcomes via majority voting, in section three. But first we define the domain restriction problem.

### C. Domain Restrictions

It is well known that even strict conditions on  $B$  will lead to a cyclic social outcome. The famous voters paradox where  $D_1 = (1,1,0)$ ,  $D_2 = (0,1,1)$  and  $D_3 = (1,0,1)$  leads to  $\bar{D} = (2/3, 2/3, 2/3)$  and from (3.2)  $D^* = f(D) = (1,1,1)$  which is cyclic. Thus if cyclicity of social choice is seen as a problem then we cannot allow  $C$  to be very large, since even with individual transitive preferences only, the majority choice might be cyclic. In general we may want the majority outcome not to belong to a subset of  $J$ . For instance, such a set might contain cyclic preferences  $CY$  or cyclic and weakly acyclic preferences and the like. Let  $\bar{P}$  be the set of preferences we wish to exclude as majority voting outcomes.

Let  $Q$  denote a family of subsets of  $J$  with the property that subsets of members of  $Q$  also belong to  $Q$ :

$$(3.6) \quad Q = \{q \mid q \subset J, \text{ if } q^1 \in Q \text{ and } q^2 \subseteq q^1 \text{ then } q^2 \in Q\}$$

$q$  is allowed if the  $n$  voters can choose any relation from  $q$  without any restrictions. Now we come to our main problem.

(3.7) We say that  $Q$  is sufficient for the  $\bar{P}$ -problem, if  $T_i \in q$ ,  $i = 1, \dots, n$ , for some  $q \in Q$  implies  $\text{Maj}(\{T_i\}) \notin \bar{P}$ .

(3.8)  $Q$  is necessary for the  $\bar{P}$ -problem if, for every  $q \subset J$ ,  $q \notin Q$ , there exists  $T_i \in q$ ,  $i = 1, \dots, n$ , such that  $\text{Maj}(\{T_i\}) \in \bar{P}$ .

The general domain restriction problem reads:

(3.9) Given  $\bar{P}$  and  $n$ , find  $Q$  that is necessary and sufficient for the  $\bar{P}$ -problem.

We first note an obvious fact:  $\bar{P} \cap q = \emptyset$  for all  $q \in Q$  if  $Q$  is sufficient for the  $\bar{P}$ -problem. Otherwise, let  $\bar{T} \in \bar{P} \cap q$  and  $T^i = \bar{T}$  for  $i = 1, \dots, n$ . Then  $\text{Maj}(\{T_i\}) = \bar{T} \in \bar{P}$  and hence not  $\bar{P}$ -sufficient.

Here we are interested only in the cyclicity properties of  $\bar{P}$ . Also we might expect the voters to always vote from a subset  $C$  of  $J$ . In that case the definition  $Q$  in (3.6) must be modified to

(3.10)  $Q = \{q \mid q \subset C, \text{ if } q^1 \in Q \text{ and } q^2 \subseteq q^1 \text{ then } q^2 \in Q\}$

That is we are interested only in the subsets of  $C$  in which individual preferences are defined. For instance, in some situations we may wish to interpret preferences strictly, excluding indifference, etc.

These concepts will be clear when we define some specific  $\bar{P}$ ,  $C$ . These will be generally (and always in this paper) defined in terms of quasitransitivity and acyclicity conditions. An example would be

(3.11)  $\bar{P} = (AC) \cup (CY)$   
 $C = TR$



which corresponds to the traditional social choice problem: Given that individuals vote transitively, what conditions must be put on the allowed lists-- i.e. in defining  $Q$ --for majority voting to lead to no cyclic or weakly acyclic relations.

The preceding analysis leads to an easy result.

Theorem 2:  $Q$  is sufficient for the  $\bar{P}$ -problem if and only if for every  $q \in Q$ , and for every  $p \in \bar{P}$ ,  $CV(q) \cap REG(p) = \emptyset$ .

Proof: Suppose  $Q$  is sufficient for the  $\bar{P}$ -problem. This implies for any  $q \in Q$ , if  $T_i \in q$ ,  $i = 1, \dots, n$ .  $Maj(\{T_i\}) \notin \bar{P}$ . Let  $D_i$  be the corresponding vectors and  $\bar{D}$  the society's vector. Then  $Maj(\bar{D})$  does not lead to a  $D \in \bar{P}$ . This by definition of  $REG$  implies  $\bar{D} \notin REG(p)$  for every  $p \in \bar{P}$ . As  $\bar{D}$  can be any convex combination of  $p$ 's  $\in q$   $CV(q) \cap REG(p) = \emptyset$ .

Suppose  $CV(q) \cap REG(p) = \emptyset \quad \forall p \in \bar{P}$ . Then no point  $a$  in  $CV(q)$  can lead to a  $p \in \bar{P}$ . As  $\bar{D}$  has to be in the convex hull of  $q$ ,  $q$  is sufficient for the  $\bar{P}$ -problem. As the condition  $CV(q) \cap REG(p) = \emptyset$  is true for all  $q \in Q$ ,  $Q$  is also  $\bar{P}$ -sufficient.

Q.E.D.

The theorem is very easy to understand from the way we constructed the model. All the sufficient conditions so far obtained in theory for majority voting can be proved by looking at the convex hull of allowed preferences and its intersection with the regions of unwanted preferences. This construction makes the generation of new sufficiency conditions straightforward.

As we noted earlier  $\bar{P}$  and  $C$  will be defined, based on acyclicity and transitivity. So, for these restrictions on  $\bar{P}$  and  $C$  we will generate sufficiency conditions.

As to necessity, we need to systematically consider all  $q$ 's belonging to the necessary  $Q$ . We also note that as  $Q$  contains many sets that are

subsets of other members we only need to concern ourselves with the maximal  $q$ 's. In a family of subsets,  $Q$ , defined by (2.19), a set  $\bar{q} \in Q$  is maximal iff  $\nexists q \in Q \ni q \supset \bar{q}$ . The technique for identifying maximal members of  $Q$  will be discussed in the next section. We now take specific cases of  $\bar{P}$  and  $C$  and develop necessary and sufficient conditions.

#### IV. The Geometry of Domain Restrictions

##### A. Transitive Individual Preferences

We will first consider the case when individuals can express only transitive orders, i.e.  $C = TR$ . Then the convex hull  $CV(C)$  is shown in Figure 4.

##### A.1 Quasitransitive social preferences

Suppose we allow quasitransitive social outcome. Then  $CY$  and  $AC$  are ruled out. So the regions ruled out are (1)  $REG(CY)$ <sup>(1)</sup>, i.e. the interior of the

Figure 4

half cubes corresponding to the two cyclic preferences and the three planes of side  $\frac{1}{2}$  passing through these two cyclic points; and (2) for points in  $AC$ ,  $REG(AC)$  which is the half squares passing through this point but excluding their two inner sides intersecting at  $(\frac{1}{2}, \frac{1}{2}, \frac{1}{2})$ . (See Figure 5).

Taking these regions out of  $CV(C)$  we get Figure 6. The interior of the intersection with the corner cubes is out, as well as the interior of the triangles  $(13,14,18)$ ,  $(13,17,18)$  and  $(13,17,14)$ , along with the lines  $(18,17)$ ,  $(18,14)$ , and  $(14,17)$ . But the lines  $(13,18)$ ,  $(13,14)$  and  $(13,17)$  are included since, if  $\bar{D}$  lies on them,  $Maj(\bar{D})$  is  $(18)$  or  $(14)$  or  $(17)$ , respectively which are quasitransitive relations.

---

<sup>(1)</sup> For any  $P \subset J$ ,  $REG(P)$  is defined as

$$\{a \in \mathbb{R}^3 \mid a \in REG(p) \text{ for some } p \in P\}.$$

Figure 5

Figure 6

For necessary and sufficient conditions we have to list all the possible  $q$ 's such that the convex hull of  $q$  does not intersect with  $REG((AC) \cup (CY))$ . This consists of two cubes complete, but for the three perpendicular lines of  $REG(TI)$ . Let us denote by  $W = CV(C) \setminus REG((AC) \cup (CY))$ , where  $q$  must contain only points from  $C$  (i.e.  $q \subset C$ ).

We first note that convex hulls of maximal  $q$ 's can be a plane in two dimensions or a three-dimensional region. But a maximal  $CV(q)$  cannot be in one dimension, for any edge or line through  $W$  will have another  $p \in C$  not on the line allowing us to form a planar maximal  $q$ .

(i) Three-dimensional  $q$ 's

A simple maximal three-dimensional (3-D) set in  $C$  is shown in Figure 7.

Figure 7

This region does not intersect  $W$ . The only place the region touches the cyclic half cubes is along the segment (13)-(15) which is included in  $W$ .  $REG(0,0,0)$  is entirely below and behind  $CV(q)$  while  $REG(1,1,1)$  is to the right of  $CV(q)$ . We also note that  $q$  contains only the preferences  $yPx$  or  $yIx$ . So we get the first sufficiency condition which was called Limited Agreement (LA) by Sen and Pattanaik [27]. There are six such shaped regions with apex (such as (2) in Figure 7) in any one of the six TS relations. Each corresponds to an ordered pair where  $xR_i y$ . Formally:

$$(4.1) \quad LA^{(1)}: \text{ For all } R_i \in q, \quad xR_i y \text{ for some } (x,y) \text{ ordered pair, } \forall i \in V$$

---

(1) Without ambiguity, a family of  $q$ 's--i.e. sets of preferences--satisfying a particular condition will be denoted by the initials of the condition, e.g. LA.

To get any other (3-D) maximal  $q$  we have to drop one or more  $p \in q$ ,  $q \in LA$ , otherwise  $q \in LA$  would not have been maximal. Points (11), (6) and (7) are symmetrical with (8), (5) and (12) in Figure 7. Only points  $p \in q$ , on a plane touching  $REG(CY)$  will be constraining in the sense that dropping them might allow us to expand and get new polytopes. Dropping (12) allows us to add (1) and get Figure 8.

Figure 8

In this volume the cyclic  $REG(1,1,1)$  is above and to the right and  $REG(0,0,0)$  is behind and below and so  $CV(C) \cap REG(P) = \emptyset$ .

In this figure we note that the preferences have one alternative, i.e.  $y$  is never last (NL) or  $xIyIzIy$ . Also we see that similar shaped 3-D polytopes can be formed by picking any four consecutive edges along the six transitive preference outer edges, i.e. (5-2), (2-6), (6-1), (1-4), (4-3) and (3-5). So there are six possible sets of  $p$ . For instance looking at the polytope originating from (1) we get Figure 9:

Figure 9

Here we note that one alternative  $y$  is never first (NF) or  $xIyIzIx$ . So we have our second sufficient condition. This was called Value Restriction by Sen and Pattanaik [27]. Formally NL and NF can be stated:

$$(4.2) \quad \text{NL: For all } R_i \in q, xIyIz, \text{ or } \exists y \in S \text{ such that} \\ xR_i y, zR_i y, \quad \forall i \in V.$$

(This is also known as the famous single-peakedness condition of Black [2]).

$$(4.3) \quad \text{NF: For all } R_i \in q, xIyIz \text{ or } \exists y \in S, \text{ such that} \\ yR_i x, yR_i z, \quad \forall i \in V.$$

We denote by  $NFL = (NL) \cup (NF)$

We can see that these two shapes are the only three-dimensional bodies such that Theorem 1 is satisfied. Let us show this fact. Suppose edge (2-11) is included in CV(C) (referring to Figure 6):

- (a) If (3-9) from the directly opposite edge is also included there are only two other maximal figures. They are:
  - (i) [(2-11),(3-9) and (5)] which is an LA polytope,
  - (ii) [(2-11),(3-9) and (6) and (4)] which is two-dimensional.
- (b) If (9-4) is included then we get (2-3-4-6) the only q which is two-dimensional.

If any part of the interior of the opposite edge (3-4) is not added the only maximal sets obtained are of the form LA or NFL. For example  $q = \{2,11,12,3\}$  is contained in (3-12-5-2-6) which is in NFL or (9-3-12-5-2-11) which is in LA. We can show this similarly for any other segment not in (3-4). Thus LA and NFL are the only three dimensional polytopes such that  $CV(C) \cap REG(\bar{P}) = \emptyset$ .

(ii) Planar Maximal W's

All the planar maximal q's not intersecting  $REG(\bar{P})$  must pass through (13) which is  $(\frac{1}{2}, \frac{1}{2}, \frac{1}{2})$ . Let us take an axis for the plane along (11-13-9) and consider the plane through (2-6-4-3). This is a maximal q (Figure 10). There are 2 other axes symmetrical to (11-3-9), namely (12-13-7) and (8-13-10). So we have our first planar condition by noting that in (2), (11), (6), (4), (9), (3) and (13)  $xIyIzIx$  or  $y$  is never in the middle. This was part of Value Restriction (VR) proposed by Sen and Pattanaik [27]. We call this NM. Note  $VR = (NFL) \cup (NM)$ .

Figure 10

$$(4.4) \quad NM: \text{ For all } R_i \in q, \exists y \in S \ni (yP_i x \text{ and } yP_i z) \text{ or } (yI_i x \text{ and } yI_i z) \text{ or } (xP_i y \text{ and } zP_i y), \quad \forall i \in V.$$

If the plane is rotated with (11-9) as the axis we get Figure 11. Again this planar hexagon does not intersect  $REG(\bar{P})$ . We note all the allowed preferences have one or three indifferences. This is the same as Dichotomous Preferences (DP) of Inada [11] and [12].

$$(4.5) \quad DP: \quad \text{For } C = TR \quad \text{for } R_i \in q \quad \exists x, y \in S \ni x I_i y, \quad \forall i \in V$$

If we tilt the plane further we get Figure 12. Here we note that if (xyz) and (zyx) are involved then xIz always among other orderings. This is the same as Antagonistic Preferences (AP) of Inada [11] and [12].

$$(4.6) \quad AP: \quad \text{For } C = TR, \quad \text{if } (xP^1yP^1z) \in q \quad \text{and } (zP^2yP^2x) \in q \\ \text{then } q \text{ contains } P^1, P^2 \text{ and orderings } \ni xIz.$$

---

Figure 11

---



---

Figure 12

---

We cannot rotate the plane further as (9), (13) and (11) are the only points in the plane. We also need not look at any other axes other than (9-11), (8-10) and (7-12) which have been included by NM, DP and AP. All the other axes through (13), entirely in  $CV(C)$ , are of type (2-13-4) which produces only AP as in Figure 12, i.e. (2-12-4-7); or NM like (2-5-4-1) or (2-3-4-6); so we have exhausted all the planar maximal  $q$ 's. Hence we have the necessary and sufficient conditions for Problem A.1, i.e. when we take  $\bar{P} = (AC) \cup (CY)$  and  $C = TR$ .

Theorem 3: (LA, NFL, NM, AP and DP) are necessary and sufficient for the  $(AC) \cup (CY)$ -problem with  $C = TR$ .

Some remarks are in order. Sen and Pattanaik proved this theorem in [27]. They called NFL and NM together Value Restriction (VR hereafter). They had another condition Extremal Restriction (ER) which was

(4.7) ER: For  $C = TR$ , if  $\exists i \ni V, xP_i yP_i z$ , then  $\forall j \neq i$

$$zP_j x \rightarrow zP_j yP_j x.$$

We can easily see what kinds of figures are allowed by ER. If  $q$  contains only members from  $TW$ , i.e. transitive preferences with indifference then ER is trivially satisfied. So let us assume  $\exists i$  such that  $xP_i yP_i z$  then we must have  $\forall j \neq i, zP_j x \rightarrow zP_j yP_j x$ . We now have two cases:

Case a)  $\exists j \neq i \ni zP_j x$ . Then only  $zPyPx$  is allowed in  $TS$  and this implies that if  $xPz$ , only  $xPyPz$  is allowed. So the only other preferences allowed have  $zIx$ , i.e.  $(zx)Py$  and  $yP(zx)$ . This is easily seen as  $AP$  (Figure 12).

Case b)  $\forall j \neq i \ni zP_j x$ . (2,8,5,12 and 3 ruled out), then either

(i)  $\exists j \neq i \ni xP_j zP_j y$ (4). So  $yP_k x \rightarrow yP_k zP_k x$ (2) which was already ruled out ( $zP_j x$  ruled out). Then (6,11) are also ruled out, so we have only the figure (7-1-10-4-9-13) as the convex hull:

Figure 13

We easily see that this volume is a subset of  $NL$  with  $x$  never last, i.e. the figure formed by (6-7-1-10-4-9-3). Or this can be also characterized by saying that  $x$  is always first (i.e.  $xRy, xRz$ ). Let us denote this class by  $AF$ .

(ii)  $\exists j \neq i \ni yP_j xP_j z$ . Then we have 4 and 9 ruled out. We get figure (11-6-7-1-10) which is a subset of  $NF$  with  $z$  never first (2-11-6-7-1-10-4). Or this is characterized by  $z$  always last (i.e.  $xRz, yRz$ ), let us call this class by  $AL$ .

(iii)  $\forall j \neq i \ni, yP_j xP_j z$  or  $xP_j zP_j zy$ . Then the allowed orderings are  $xPyPz, yP(zI), (xIz)Py, (xIy)Pz, xP(yIz)$  and  $xIyIz$ . The figure is (1-7-11-13-9-10-1) as in Figure 14.

Figure 14

This is easily seen as a subset of LA with  $xRz$ . Let us denote this set by  $\overline{LA}$ . So this case has also been taken care of and we see that  $(VR) \cup (LA) \cup (ER) = (LA) \cup (VR) \cup (AP) \cup (DP)$ . But keeping AP and DP avoids double counting with VR or LA when ER is used, as noted by Inada [12].

A.2 Transitive Social Preferences

Here  $C = TR$ . But  $\overline{P} = (CY) \cup (AC) \cup (TI)$ .  $REG(\overline{P})$  includes the interior of all the half lines emanating from  $(\frac{1}{2}, \frac{1}{2}, \frac{1}{2})$  to the TI points. This case illustrates the power of our analysis to generate new results.

There are two types of necessary and sufficient conditions we can talk about (i) The number of concerned voters, denoted as  $\overline{n}$  (those who do not vote  $xIyIz$ ) is unrestricted, (ii)  $\overline{n}$  is restricted through some conditions.

Pattanaik and Sengupta [19] and Fishburn [4] assumed that  $\overline{n}$  was odd. Here we derive a theorem with weaker conditions on  $\overline{n}$ , for necessity and sufficiency of social TR-type preferences. This will be case (ii) where  $\overline{n}$  will have to satisfy some requirement for which  $\overline{n}$  being odd will be sufficient but not necessary.

Let us consider case (i) first. If  $\overline{n}$  is unrestricted we must make sure that  $\overline{D}$  never fall on  $REG(TI)$  or the half-lines from  $(\frac{1}{2}, \frac{1}{2}, \frac{1}{2})$ . In LA (Figure 7) we see that  $\overline{D}$  can lie on the line (13-15) which is  $REG(15)$ . So LA is not sufficient. We also see that with NL as in Figure 8, (15-13) and (13-18) are in  $REG(TI)$ . So NL is not sufficient and similarly NF is also not sufficient. We also see NM is not sufficient as (17-13-18) is in  $REG(TI)$ . Together we see VR is not sufficient.



But we see that the hexagon of DP in Figure 11 does not intersect REG(TI) (13 does not belong to REG(TI)). It is also obvious that AP (in Figure 12) is sufficient. AF (as in Figure 13) does not intersect any REG(TI). This is also maximal as we cannot add  $yPxPz$  (6) as a  $\bar{D}$  can be on (6-9) and REG(16). Similarly AL is sufficient. We also note that  $\bar{LA}$  (of Figure 14) is also sufficient. This is also seen to be maximal. Together we can say ER is sufficient. It is easily verified that these are the only families of sufficient conditions. So we have:

Theorem 4: If  $\bar{n}$  is unrestricted, ER is necessary and sufficient for the  
 $(AC) \cup (CY) \cup (TI)$ -problem with  $C = TR$ .

For case (ii) ER is still sufficient.

For case (ii), i.e. with conditions on  $\bar{n}$  if  $q$  satisfies LA the only TI preferences that can result is (15)  $zIyPxIz$  which will occur if and only if  $\bar{D}$  falls on (13-15) line excluding (13). This will occur if and only if half the total number of voters concerned vote on the line (12-5) and the other half votes on the line (6-7). If even any one concerned voter votes away from these two lines (6-7) or (5-12)  $\bar{D}$  will not lie on the line (13-15). So if  $q$  satisfies LA, a necessary and sufficient condition for transitive social outcomes with  $C = TR$  would be:

$$(4.8) \quad LAO: \text{ For } C \subset TR, \text{ for all } R_i \in q, \text{ for some ordered pair } x, y \in S \quad yR_i x \text{ for all } i \in V \text{ and for } z \neq x \quad z \neq y,$$

$$(4.9) \quad [N(\text{ranking } z \text{ uniquely first}) \neq \frac{\bar{n}}{2}] \quad \text{or}$$

$$(4.10) \quad [N(\text{ranking } z \text{ uniquely last}) \neq \frac{\bar{n}}{2}]$$

Here  $N(\cdot)$  is the number of people voting the way indicated inside the bracket.

If  $\bar{n}$  is odd  $\bar{n}/2$  is fractional and immediately LAO is satisfied if LA is satisfied. This is the case Pattanaik and Sengupta [19] considered and our conditions are weaker and also necessary and sufficient. The following example illustrates a case where our condition is satisfied while theirs is not:

$$\begin{array}{ll} z(xy) & \text{for } i = 1,2 \\ z y x & \text{for } i = 3 \\ y x z & \text{for } i = 4 \\ (xy)z & \text{for } i = 5 \\ yzx & \text{for } i = 6,7,8 \end{array}$$

They all satisfy LA with  $yR_i x$  for  $i = 1, \dots, 7$ . But the number of concerned individuals is even (=8). Majority voting leads to  $yPz, zPx, yPx \Rightarrow yzx$  for the society. So the result is: if transitive social orderings are required,  $\bar{n}$ , odd will guarantee that LA leads to transitive ordering. But our LAO is sufficient. Note finally that if only (12), (7) are voted AP is satisfied, which has been treated earlier.

Similarly if  $q$  satisfies NF as in Figure 9 only the lines (19-13) and (14-13) lead to TI. Again the only way  $\bar{D}$  will lie on (13-14) is if the number of people voting the line (5-3) equals  $\bar{n}/2$  and those voting (1) is also  $\bar{n}/2$ , i.e.  $N(z \text{ uniquely first}) = \bar{n}/2$  and  $N(z \text{ uniquely last}) = \bar{n}/2$ . Similarly for  $\bar{D}$  not to lie on (13-19),  $N(x \text{ uniquely last}) \neq \bar{n}/2$  or  $N(x \text{ uniquely last}) \neq \bar{n}/2$ . But then note that in this pattern ( $q$ )  $N(z \text{ uniquely first}) \geq N(x \text{ uniquely last})$  and  $N(x \text{ uniquely first}) \geq N(z \text{ uniquely last})$ . So if  $N(z \text{ uniquely first})$  is  $> \bar{n}/2$  then the social outcome will be on line 5-3. If  $N(z \text{ uniquely first})$  is  $< \bar{n}/2$  then even if  $N(z \text{ uniquely last}) = N(z \text{ uniquely first}) < \bar{n}/2$   $\bar{D}$  will not be on the plane (5-3-1) and hence not on (13-14). So the necessary and sufficient condition if NF is satisfied is

$$(4.11) \quad \text{NFO: For } C = TR \text{ for all } R_i \in q, xIyIz \text{ or } \exists y \in S \ni \\ yR_i x, yR_i z, \quad \forall i \in V \text{ and}$$

$$(4.12) \quad [[N(x \text{ uniquely last}) \neq \bar{n}/2] \text{ or } [N(x \text{ uniquely first}) \neq \bar{n}/2]] \text{ and}$$

$$(4.13) \quad [[N(z \text{ uniquely last}) \neq \bar{n}/2] \text{ or } [N(z \text{ uniquely first}) \neq \bar{n}/2]].$$

Here again if  $\bar{n}$  is odd then the conditions (4.12 and 4.13) are immediately satisfied. Our conditions are also weaker than just requiring  $\bar{n}$  to be odd and are sufficient and necessary.

Similarly for NL we can write NLO as:

$$(4.14) \quad \text{For } C = \text{TR, for all } R_i \in q, \ xIyIz \text{ or } \exists y \in S \ni \\ zR_iy, \ xR_iy, \quad \forall i \in V \quad \text{and}$$

$$(4.15) \quad [[N(x \text{ uniquely first}) \neq \bar{n}/2] \text{ or } [N(x \text{ uniquely last}) \neq \bar{n}/2]] \text{ and}$$

$$(4.16) \quad [[N(z \text{ uniquely first}) \neq \bar{n}/2] \text{ or } [N(z \text{ uniquely last}) \neq \bar{n}/2]].$$

Let NFLO denote NFO and NLO.

If  $q$  satisfies NM, then it is obvious from Figure 10 that if  $N(y \text{ uniquely first}) \neq \bar{n}/2$  or  $N(y \text{ uniquely last}) \neq \bar{n}/2$   $\bar{D}$  will not lie on (16-17). So we again have a weaker sufficient and necessary condition:

$$(4.17) \quad \text{NMO: For } C = \text{TR, for all } R_i \in q, \quad \exists y \in S \ni (yI_i x \text{ and } yI_i z) \text{ or} \\ (yP_i x \text{ and } yP_i z) \text{ or } (xP_i y \text{ and } zP_i y), \quad \forall i \in V \text{ and}$$

$$(4.18) \quad [N(y \text{ uniquely first}) \neq \bar{n}/2] \text{ or}$$

$$(4.19) \quad [N(y \text{ uniquely last}) \neq \bar{n}/2].$$

With these we can state the following

Theorem 5: LAO, NFLO, NMO and ER are necessary and sufficient for the (CY)  $\cup$  (AC)  $\cup$  (QT)-problem with  $C = \text{TR}$ .

This is a complete generalization of Pattanaik and Sengupta's result.

### A.3 Weakly Acyclic Social Preferences

Here  $\bar{D}$  is just CY.  $\bar{D}$  can lie on the inner sides of the half-cubes of the REG(CY). The regions that were dropped from REG( $\bar{P}$ ) for  $\bar{P} = (CY) \cup (AC)$  were the inner sides of the half-cubes of the REG(CY). But since they can occur only if the TI preferences of individual relations are allowed this does not increase any of the old maximal q's (of section 3.A for social QT preferences). So the same conditions of 3.A hold good, i.e.

Theorem 6: LA, NFL, NM, AP and DP are necessary and sufficient for the (CY)-problem with  $C = TR$ .

### B. Individual QT Relations

In this section we allow all the individual relations from QT, i.e.  $C = QT$ . Surprisingly CV(C) still looks as in Figure 4 which was also CV(TR).

#### B.1 Quasitransitive Social Relations

Here  $\bar{P} = (CY) \cup (AC)$ . We still get the region  $CV(C) \setminus REG(\bar{P})$  as in Figure 6. The interior of the sides of the half-cubes of REG(CY) are not included and only the half-lines from (13) to (19), (18), (17), (16), (15) and (14) are included.

The LA condition region of Figure 7 is still maximal. We cannot add any adjacent point to the polytope. For instance (18) cannot be added as (18-12) intersects with REG(23). Similarly (17) cannot be added as (17-7) intersects with REG(23). Other points were as before in section IV.A.1. We exclude (16), (17), (18) and (19) by

$$(4.20) \quad \text{LAQ: For all } R_i \in q, xR_i y \text{ if } T_i \in TR \text{ and } xP_i y \text{ if } T_i \in QT \\ \forall i \in R$$

for some ordered pair (x,y).

Similarly for NL we cannot increase the maximal set as the planes (5-2-1) and (5-1-6) were constraining. So NL and NM are still maximal q's. Also (16) cannot be added; y is still never last as defined in (4.2). For in the added relations (15:  $zIyPxIz$ ), and (18:  $xIyPzIx$ ) y is still not last. Therefore NFL is sufficient.

Then we come to the planar conditions. NM as in Figure 10 is still sufficient. Relation (11) and (16) are added  $yIzPxIy$  and  $yIxDzIy$ . Here we have  $xRy$ ,  $yRz$  but both R's are indifferences. But these two relations are allowed by the definition NM of 4.4.

DP and AP still hold good and are sufficient. We cannot rotate the plane any more along the axis (11-9) since when it is perpendicular to the zx axis it touches the sides of REG(AC) planes. So there are no new polytopes. Hence we have:

Theorem 7: LAQ, NFL, NM, AP and DP are necessary and sufficient  
for the (AC) U (CY)-problem with  $C = QT$ .

## B.2 Transitive Social Relations

Here  $\bar{P} = (CY) \cup (AC) \cup (TI)$  and  $C = QT$ . Pattanaik and Sengupta [19] have shown that if Q contains LAQ, NFL, NM, AP and DP and if the number of concerned transitive individuals is odd, majority voting will lead to transitive social preferences. Again we develop weaker conditions.

As we discussed earlier the only way a quasitransitive social preference will occur is if  $\bar{D} \in \text{REG}(TI)$ . These regions are the half-lines joining  $(\frac{1}{2}, \frac{1}{2}, \frac{1}{2})$  with the TI points. Let  $\tilde{n}$  be the number of individuals voting transitively and who are concerned--i.e. do not vote  $xIyIzIx$ .

For LA type conditions Figure 7 still holds. The only way  $\bar{D}$  can lie on REG(TI) is for  $\bar{D}$  to fall in (13-15). This will not occur for LA if and

only if (i) the number of people voting on the line (5-12) is not equal to the number of people voting on (6-7) or (ii) if they are equal it should not be  $\tilde{n}/2$ . In the first case  $\bar{D}$ , even if it lies on the plane (5-12-7-6), will not lie on (13-15) and in the second case  $\bar{D}$  will not lie on the plane (5-12-7-6). This can be stated as:

$$(4.21) \quad \text{LAQO: For all } R_i \in q, yR_i x \text{ if } T_i \in TR \text{ and } yP_i x \text{ if } \\ T_i \in TI, \quad \forall i \in S \text{ for some ordered pair } (y,x) \text{ and for } \\ z \neq x, z \neq y \text{ and}$$

$$(4.22) \quad [N(\text{ranking } z \text{ uniquely first}) \neq \tilde{n}/2] \text{ or}$$

$$(4.23) \quad [N(\text{ranking } z \text{ uniquely last}) \neq \tilde{n}/2] .$$

Again if  $\tilde{n}$  is odd (4.22) and (4.23) will be satisfied; this case was treated by Pattanaik and Sengupta. Even if  $\tilde{n}$  is even LAQO might be satisfied and so LAQO is weaker and is sufficient. It is also obvious that it is necessary since if both the  $N(\cdot)$ 's are equal to  $\tilde{n}/2$ ,  $\bar{D}$  will lie on (15-13) excluding 13. Also, if only (12) and (7) are voted AP will be satisfied.

Similarly if  $q$  satisfies NF as in Figure 9 we can argue along the lines developed in section IV.A.2 and get the conditions NFQO and NEQO as:

$$(4.24) \quad \text{NFQO: For } C = QT \text{ for all } R_i \in q, xIyIz \text{ or } \exists y \in S \ni \\ yR_i x, yR_i z, \quad \forall i \in V \text{ and}$$

$$(4.25) \quad [[N(x \text{ uniquely last}) \neq \tilde{n}/2] \text{ or } [N(x \text{ uniquely first}) \neq \tilde{n}/2]] \text{ and}$$

$$(4.26) \quad [[N(z \text{ uniquely last}) \neq \tilde{n}/2] \text{ or } [N(z \text{ uniquely first}) \neq \tilde{n}/2]].$$

$$(4.27) \quad \text{NLQO: For } C = QT \text{ for all } R_i \in q, xIyIz \text{ or } \exists y \in S \ni \\ zR_i y, xR_i y, \quad \forall i \in V \text{ and}$$

$$(4.28) \quad [[N(x \text{ uniquely first}) \neq \tilde{n}/2] \text{ or } [N(x \text{ uniquely last}) \neq \tilde{n}/2]] \text{ and}$$

$$(4.29) \quad [[N(z \text{ uniquely first}) \neq \tilde{n}/2] \text{ or } [N(z \text{ uniquely last}) \neq \tilde{n}/2]].$$

Similarly if  $q$  satisfies NM as in Figure 10, in the same way as we defined NMO in section IV.A.2 we get:

$$(4.30) \quad \text{NMQO: For } C = \text{QT, } \forall R_i \in q, \exists y \in S \ni (yP_i x \text{ and } yP_i z) \text{ or } (yI_i x \text{ and } yI_i z) \text{ or } (xP_i y \text{ and } zP_i y) \quad \forall i \in V$$

and

$$(4.31) \quad [N(y \text{ uniquely first}) \neq \tilde{n}/2] \quad \text{or}$$

$$(4.32) \quad [N(y \text{ uniquely last}) \neq \tilde{n}/2].$$

Let  $\text{VRQO} = (\text{NFQO}) \cup (\text{NLQO}) \cup (\text{NMQO})$ .

We can easily see that if  $q$  satisfies AP or DP,  $\bar{D}$  will never lie on  $\text{REG}(\text{TI})$ . With these we have the following:

Theorem 8: LAQO, VRQO and ER are necessary and sufficient for the  $(\text{TI}) \cup (\text{AC}) \cup (\text{CY})$ -problem with  $C = \text{QT}$ .

### B.3 Acyclic Social Relations

Here  $\bar{P} = \text{CY}$ . The regions that are dropped from the old  $\text{REG}(\bar{P})$  are the inner sides of the half-cubes of  $\text{REG}(\text{CY})$ . We can expand the LA shape into Figure 15

Figure 15

Two QT preferences have been added (17:  $yIzPxIy$ ) and (18:  $xIyPzIx$ ). All the allowed relations can be expressed as:

$$(4.33) \quad \text{LAC: For all } R_i \in q, \text{ for some ordered pair } (x, y) \text{ and } z \neq x$$

$$z \neq y, yR_i x \text{ and if } zP_i y, zP_i x \text{ and if } xP_i z, yP_i z$$

We note that NL, NF and NM cannot be expanded. AP and DP are also maximal. But we see that AF (x always first) in Figure 13 can be expanded by adding (19)  $xIzPyIx$ , (14)  $zIxPyIz$ , (18)  $xIyPzIx$  and (16)  $yIxPzIy$ . All the allowed relations have  $xRy$  and  $xRz$  (Figure 16). We can define AFC as:

AFC:  $\forall R_i \in q, \exists x \ni xR_i y, xR_i z.$

Similarly for AL we can define ALQ as:

ALQ: For  $\forall R_i \in q, \exists x \ni yR_i x, zR_i x.$

---

Figure 16

---

In Figure 15 the face (13-14-18) lies on REG(20) (Figures 1 and 6), and a  $\bar{D}$  on that face will lead to the acyclic relation  $yPzIxPy$ . We can state our result as:

Theorem 9: VR, LAC, ER, AFC and ALC are necessary and sufficient for the (CY)-problem with  $C = QT$ .



## V. Distributional Conditions

So far we have looked only at the conditions that were defined on the subsets of profiles. If the voters chose their preferences from that set then quasi-transitive majority social relations (QMSR) were guaranteed. Another way of imposing restrictions is to specify some conditions on the distribution of voters. In this section we consider only transitive individual relations, i.e. (1 to 13). A distribution of voters is the set of number of voters voting relations (1) to (13). These will be represented by  $n_i$ ,  $i = 1, \dots, 13$ ; as unconcerned individuals do not matter in majority voting we need to look only at  $\bar{n} = \sum_{i=1}^{12} n_i = \bar{n}$  and hereafter we have  $\bar{n} = n$ .

This line of attack was considered by Nicholson [15 ], Saposnik [21], Slutsky [28] and Gaertner [7 ]. Our geometric construction can be used to analyse these conditions. A sufficient condition of distributional nature specifies conditions on the set  $n_i$ . We first allow only strict preferences (1 to 6), and then look at some extensions.

### A. Strict preferences:

The convex hull of allowed preferences is the same as in figure 7. To simplify our analysis we use a reduction procedure which, given a distribution  $n_i$ ,  $i=1, \dots, 6$ , produces an equivalent but more easily handled distribution.

We follow Slutsky [28] as he has developed necessary and sufficient conditions for transitive majority decisions. Let  $V$  denote the society by which we mean a set  $\{n_i\}$ ,  $i=1, \dots, 6$ . Since we are considering majority voting which depends only on the number of people having strict preferences for one alternative over another, individual indifferences do not matter. So

to any society we can add people with complete indifferences and this will not alter the majority voting outcome. We recall that  $\bar{D}$  has been defined as the average of the  $D_j$  vectors of the voters,  $j=1, \dots, n$  and, for majority voting, the function  $f$  in equation (2.13) took the difference between  $\bar{D}$  and  $\{\frac{1}{2}, \frac{1}{2}, \frac{1}{2}\}$  to determine the group preference. Note that adding indifferent individuals although it changes  $\bar{D}$ , does not change the outcome under  $f$ . So if two individuals have opposite preferences e.g.  $xPyPz$  and  $zPyPx$  then we can drop both voters without changing the outcome.

Two societies  $V_1$  and  $V_2$  are said to be equivalent iff  $N(xP_i y) - N(yP_i x) = N(xP_j y) - N(yP_j x)$  for  $i \in V_1$  and  $j \in V_2 \forall y, x \in S$ .

A society  $V$  is said to be irreducible if there exists no group of individuals within it, who are indifferent between the alternatives under majority voting among themselves.

There are three pairs of preferences (1,5), (3,6) and (2,4) which are opposite so a procedure to form the irreducible society  $\tilde{V}$  from any  $V$  is to remove pairs of voters, voting opposite preferences. Formally, given  $n_i$ 's, and letting  $n_{i,j} = \min [n_i, n_j]$   $\tilde{n}_i$ 's of  $\tilde{V}$  are given by:

$$(5.1) \quad \tilde{n}_1 = n_1 - n_{1,5} \quad \tilde{n}_3 = n_3 - n_{3,6} \quad \tilde{n}_4 = n_4 - n_{4,2}$$

$$\tilde{n}_5 = n_5 - n_{1,5} \quad \tilde{n}_6 = n_6 - n_{3,6} \quad \tilde{n}_2 = n_2 - n_{4,2}$$

$$(5.2) \quad \text{Total number of voters in } \tilde{V} = \tilde{n} = \sum \tilde{n}_i = n - 2(n_{1,5} + n_{3,6} + n_{2,4})$$

Let

$$(5.3) \quad n_I = n_1 + n_2 + n_3; \quad n_{II} = n_4 + n_5 + n_6 .$$

Geometrically we are looking at the three diagonals (1-5), (2-4) and (3-6) and take a majority vote on the pair. The winner will be one of the pair and in  $\tilde{V}$  that winner receives the difference between the  $n_i$ 's. The

operation of majority voting just takes the closest transitive vertex to the weighted centroid. It is obvious that if two societies  $V_1$  and  $V_2$  are equivalent they will have the same majority outcome. If

$N(xP_i y) - N(yP_i x) > 0$ ,  $\bar{D}^{xy} > \frac{1}{2}$  as there are more ones than zeroes as  $D_i$ 's. The following Lemma describes the procedure of (5.1)

Lemma: The social preference order under majority voting does not change from  $V$  to  $\tilde{V}$  as defined in (5.1)

Proof:

Let us pick a pair, say  $(x,y)$

$$\bar{D}^{xy}(V) = \frac{n_1 + n_4 + n_3}{n}$$

$$\bar{D}^{xy}(\tilde{V}) = \frac{\tilde{n}_1 + \tilde{n}_4 + \tilde{n}_3}{\tilde{n}}$$

$$= \frac{(n_1 + n_4 + n_3 - (n_{1,5} + n_{3,6} + n_{2,4}))}{(n - 2(n_{1,5} + n_{3,6} + n_{2,4}))}$$

$$\text{Let } n_1 + n_4 + n_3 = \alpha, \quad n_{1,5} + n_{3,6} + n_{2,4} = \beta$$

By definition of  $n_{ij}$ ,  $\beta \leq \alpha$  and  $n > 2\beta$  (If  $n = 2\beta$ ,  $\bar{D}^{xy}(V) = \frac{1}{2} = \bar{D}^{xy}(\tilde{V})$ )

$$\bar{D}^{xy}(V) = \alpha/n, \quad \bar{D}^{xy}(\tilde{V}) = \alpha - \beta / n - 2\beta$$

$$\frac{\alpha}{n} - \frac{\alpha - \beta}{n - 2\beta} = \frac{\alpha n - 2\alpha\beta - \alpha n + \beta n}{n(n - 2\beta)}$$

$$= \frac{\beta(n - 2\alpha)}{n(n - 2\beta)}$$

$$> 0 \text{ if } n > 2\alpha$$

$$< 0 \text{ if } n < 2\alpha$$

So if  $\alpha/n < \frac{1}{2}$  i.e.  $\bar{D}^{xy}(V) < \frac{1}{2}$ ,  $\bar{D}^{xy}(V) > \bar{D}^{xy}(\tilde{V})$

and if  $\alpha/n > \frac{1}{2}$  i.e.  $\bar{D}^{xy}(V) > \frac{1}{2}$ ,  $\bar{D}^{xy}(V) < \bar{D}^{xy}(\tilde{V})$

In either case  $\bar{D}(\tilde{V})$  stays on the same side of  $\frac{1}{2}$  as  $\bar{D}(V)$

So  $\tilde{V}$  defined as in 5.1 does not change the social outcome through majority voting

Q.E.D.

So given a society  $V$ , we can reduce it through (5.1) to  $\tilde{V}$  which is irreducible. The irreducibility of  $\tilde{V}$  can be seen from the fact that three of the six  $\tilde{n}_i$ 's are equal to zero and only one from each pair (1,5), (3,6) and (2,4) - the diagonals - is positive. Now if all three non zero  $\tilde{n}$  are from the same cycle, say I - i.e. (1),(2),(3) - it is obvious that the indifference point (13) -  $(\frac{1}{2}, \frac{1}{2}, \frac{1}{2})$  - cannot obtain. And further if two are from one cycle and one from the other (II) say, for instance, (1),(2) and (6) then again the centroid will lie on a face of the cube which again rules out point (13).

#### B. Distribution Restrictions

We first note that distribution restrictions can be accommodated by our general theorem 2 after suitable reinterpretation of the convex hull of  $q$ 's,  $CV(q)$ . Instead of  $CV(q)$  we should look at the convex hull allowed by the restrictions on  $n_i$ 's.

Slutsky [28] derived the following theorem:

Theorem 10 (Slutsky): For  $C=TR$  majority voting will lead to transitive social preferences if and only if one of the following conditions is satisfied:

- (i)  $(n_1 - n_5)(n_2 - n_4) < 0$
- (ii)  $(n_1 - n_5)(n_3 - n_6) < 0$
- (iii)  $(n_2 - n_4)(n_3 - n_6) < 0$
- (iv)  $n_I = n_{II}$
- (v)  $|n_1 - n_5 + n_2 - n_4| < (\frac{1}{2})|n_I - n_{II}|$
- (vi)  $|n_1 - n_5 + n_3 - n_6| < (\frac{1}{2})|n_I - n_{II}|$
- (vii)  $|n_2 - n_4 + n_3 - n_6| < (\frac{1}{2})|n_I - n_{II}|$ .

Here again the theorem can be readily seen geometrically.

Let us assume that the society  $V$ , has already been reduced to  $\tilde{V}$ . Then one  $n_i$  in each pair of  $(n_1 \text{ or } n_5)$ ,  $(n_2 \text{ or } n_4)$  and  $(n_3 \text{ or } n_6)$  is equal to zero. ( $n_i$ 's are  $\tilde{n}_i$ 's i.e. they are reduced).

In majority voting since  $\bar{D}$  is formed as a sum we can look at a partial sum. Assume condition (i) holds then one of  $(n_1 - n_5)$  or  $(n_2 - n_4)$  must be less than 0 and the other greater than 0. Suppose  $n_1 - n_5 < 0$  then  $n_1 = 0$ ,  $n_5 > 0$  and  $n_2 > 0$  and  $n_4 = 0$ . This means the partial  $\bar{D}$  with  $n_1, n_2, n_4$ , and  $n_5$  will lie on (2-5). The partial  $\bar{D}$  of  $n_3$  and  $n_6$  will be on the diagonal and the social  $\bar{D}$  will lie inside the convex hull formed by (2-5) and (6-3). We immediately see that is the same as a convex hull formed by NF preferences with  $x$  never first as in figure 9.

Suppose (i) is satisfied,  $n_1 - n_5 > 0$  then  $n_1 > 0$ ,  $n_5 = 0$ ,  $n_2 = 0$ ,  $n_4 > 0$  and  $\bar{D}$  will lie in the convex hull of (1-4) and (3-6) and this is NL with  $x$  not last. So (i) (ii) and (iii) are sufficient for transitive majority outcomes. If all of (i), (ii) and (iii) are not satisfied then one  $n_i$  from  $(n_1, n_2, n_3)$  is  $> 0$  if and only if all  $n$ 's from  $(n_4, n_5, n_6)$  are  $= 0$  or all  $n_i = 0$ ; and the converse is also true.

If (iv),  $n_I = n_{II}$  (even for unreduced  $n_i$ 's) is satisfied then we can see that  $\bar{D}$  will lie on the hexagon formed by (7-8-9-10-11-12) (see figure 11) The convex hull of (I) is the triangle (1-2-3) and the convex hull of II is (4-5-6) and the partial  $\bar{D}$ 's lie on the two triangles. The two triangles are parallel to the hexagon and are equidistant from it. One planar view would be as shown in Figure 17.

Figure 17

If  $n_I = n_{II}$  the convex hull is the hexagon and  $\bar{D}$  does not lie in  $REG(\bar{P})$ .

This is the region covered by the Dichotomous Preferences of Inada. The condition  $n_I = n_{II}$  was first obtained by Saposnik [21]. Gaertner and Heinecke [8] noticed the connection between DP and this condition (iv) which was called Cyclical Balance by Saposnik. Our geometric approach shows immediately that both describe the same region. In this case if the  $n_i$ 's are reduced  $n_I = n_{II} = 0$ . Even if indifferences are allowed this condition is sufficient since  $CV(TW)$  is that hexagon.

If conditions (i) - (iv) are not satisfied then if one  $n_i$  from  $(n_1, n_2, n_3)$  is  $> 0$ ,  $n_4 = n_5 = n_6 = 0$ ; and the converse is also true. That is if the  $n_i$ 's are reduced  $\tilde{n}_i$ 's then  $\bar{D}$  lies on the triangle (1-2-3) or (4-5-6). Suppose it lies on (1-2-3) as in figure 18

Figure 18

If  $\bar{D}$  lies in the interior of the triangles (2-17-18)  $A_2$ , (14-17-3)  $A_3$ , or (1-18-14)  $A_1$  then  $f(\bar{D})$  will be transitive and the outcome will be  $f(\bar{D}) = i$  for  $\bar{D} \in A_i$ . As  $n_{II} = 0$  if (v) is satisfied then  $(n_1 + n_2) < \frac{1}{2} (n_1 + n_2 + n_3)$  or  $n_3 > n_1 + n_2$ . Then  $\bar{D}$  will lie in  $A_3$  as the weight on the line (1 - 2) is less than the weight on (3). Similarly if (vi) is satisfied then  $\bar{D} \in A_2$  and if (vii) is satisfied then  $\bar{D} \in A_1$ . We also see that if  $\bar{D}$  lies on (1-2-3) then (v) through (vii) are necessary and sufficient for  $\bar{D}$  not to lie in  $REG(\bar{P})$  - the shaded triangle in figure 18. Similarly if  $n_I = 0$ , i.e.  $n_1 = n_2 = n_3 = 0$  then at least one of  $n_4$ ,  $n_5$  or  $n_6$  is  $> 0$  (if all are equal to 0, (iv) is satisfied) and  $\bar{D}$  lies on the (4-5-6) triangle. Then  $n_I - n_{II} < 0$  and if (v) is satisfied  $n_6 > n_4 + n_5$  and we see that (v), (vi) and (vii) are sufficient.

As we have gone through the conditions in a sequence if none of (v), (vi) or (vii) is satisfied then  $\bar{D}$  must lie in (14-7-18) or (15-16-19) (including boundaries) and this will lead to an intransitive social outcome. So it is also necessary that at least one of (i) to (vii) be satisfied.

These conditions can also be extended to include indifferences in individuals' preferences. But the conditions become complicated and have no 'nice' interpretation short of saying the obvious, namely that "majority voting should work." The distributional conditions of theorem 10 were discussed because they are easier to interpret using the lattice structure. We can also see that for  $\bar{P} = (AC) \cup (CY)$ , i.e. if quasitransitive social preferences are allowed we can relax (i), (ii) and (iii) to weak inequalities. If the equality sign holds for one of (i) to (iii) then in one of the pairs  $(n_1, n_5)$ ,  $(n_2, n_4)$  or  $(n_3, n_6)$  both  $n_i$ 's are equal to 0; and we get a plane such as NM (Figure 10) which is sufficient. If only weak acyclicity is required then we can relax (v) to (vii) also to weak inequalities. Then  $\bar{D}$  is allowed to lie on the boundary of the triangle (14-17-18) and this guarantees weakly acyclic social outcome.

By this geometric construct we see the correspondence between (i) to (iii) and NFL and between (iv) and DP. Having shown the power of this analysis we are now in a position to summarize the results discussed so far.

VI. Summary and Conclusion

We have seen that VR, LA and ER guarantee social QT relations. These are also necessary and sufficient for social WA preferences. If we want the social outcome to be TR then we need distributional requirements like those in IV-B. We also saw that ER is sufficient and necessary if  $\bar{n}$  is unrestricted. Thus the mileage gained by relaxing the social outcome from TR to QT is on distributions of  $\bar{n}$  (or addition of LA and VR), while relaxing QT to WA yields nothing as noted by Sen [26].

But if individual preferences are allowed to be quasitransitive then there are definite gains when the permissible social outcome is relaxed from TR to QT and QT to WA: the distributional conditions can be dropped. If only a WA social outcome is required then LAC over LAQ, and AFC and ALC are additional gains. But the AC relations we considered were only for three alternatives and it remains to be seen how these conditions can be extended to more than 3 alternatives.

The distributional conditions of section V can also be extended. But they lose their simple structure and become tautological - stating in effect that majority voting should work. We can summarize the necessary and sufficient conditions for the pair of individual and social relations on three alternatives in the following table.

SOCIETY INDIVIDUALS	TR	QT	WA
TR	$\bar{n}$ unrestricted $\rightarrow$ ER <hr/> VRO, LAO and ER	VR, LA and ER	VR, LA and ER
QT	$\tilde{n}$ unrestricted $\rightarrow$ ER <hr/> VRQO, LAQO and ER	VR, LAQ and ER	VR, LAC, ER AFC and ALC



References

- [1] Arrow, K.J. Social Choice and Individual Values, 2nd ed. (New York: John Wiley and Sons, 1963).
- [2] Black, D. The Theory of Committees and Elections (Cambridge University Press, Cambridge, 1958).
- [3] Fishburn, P.C. "Intransitive Individual Indifference and Transitive Majorities," Econometrica, 38 (1970).
- [4] \_\_\_\_\_. "Conditions for Simple Majority Decision Functions with Intransitive Individual Indifference," Journal of Economic Theory, 2 (1970).
- [5] \_\_\_\_\_. "Conditions on Preferences that Guarantee a Simple Majority Winner," Journal of Mathematical Sociology, 2 (1972).
- [6] \_\_\_\_\_. The Theory of Social Choice (Princeton, New Jersey: Princeton University Press, 1973).
- [7] Gaertner, W. "An Analysis and Comparison of Several Necessary and Sufficient Conditions for Transitivity Under the Majority Decision Rule," (University of Bielefeld), 1976.
- [8] \_\_\_\_\_ and A. Heinecke. "On Two Sufficient Conditions for Transitivity of the Social Preference Relation" (University of Bielefeld), 1976.
- [9] Grandmont, J.M. "Intermediate Preferences and The Majority Rule," Econometrica, 46 (1978).
- [10] Inada, K. "A Note on the Simple Majority Decision Rule," Econometrica, 32 (1964).
- [11] \_\_\_\_\_. "On the Simple Majority Decision Rule," Econometrica, 37 (1969).
- [12] \_\_\_\_\_. "Majority Rule and Rationality," Journal of Economic Theory, 2 (1970).
- [13] Kelly, J.S. "Necessity Conditions in Voting Theory," Journal of Economic Theory, 8 (1974).

- [14] May, K.O. "A Set of Independent, Necessary and Sufficient Conditions for Simple Majority Decision," Econometrica, 20 (1952).
- [15] Nicholson, M.B. "Conditions for the 'Voting Paradox' in Committee Decisions," Metroeconomica, 42 (1965).
- [16] Pattanaik, P. "A Note on Democratic Decisions and the Existence of Choice Sets," Review of Economic Studies, 35 (1968).
- [17] \_\_\_\_\_. "On Social Choice with Quasitransitive Individual Preferences," Journal of Economic Theory, 2 (1970).
- [18] \_\_\_\_\_. Voting and Collective Choice (Cambridge: Cambridge University Press, 1971).
- [19] \_\_\_\_\_ and M. Sengupta. "Conditions for Transitive and Quasi-transitive Majority Decisions," Econometrica, 41 (1974).
- [20] Plott, C.R. "A Notion of Equilibrium and Its Possibility Under Majority Rule," American Economic Review, 57 (1967).
- [21] Saposnik, R. "On Transitivity of the Social Preference Relation Under Simple Majority Rule," Journal of Economic Theory, 10 (1975).
- [22] Sen, A.K. "Preferences, Votes and the Transitivity of Majority Decisions," Review of Economic Studies, 31 (1964).
- [23] \_\_\_\_\_. "A Possibility Theorem on Majority Decisions," Econometrica, 34 (1966).
- [24] \_\_\_\_\_. "Quasi-Transitivity, Rational Choice and Collective Decisions," Review of Economic Studies, 36 (1969).
- [25] \_\_\_\_\_. Collective Choice and Social Welfare (San Francisco: Holden-Day, Inc., 1970).
- [26] \_\_\_\_\_. "Social Choice Theory: A Re-examination," Econometrica, 45 (1977).
- [27] \_\_\_\_\_ and P. Pattanaik. "Necessary and Sufficient Conditions for Rational Choice Under Majority Decision," Journal of Economic Theory, 1 (1969).
- [28] Slutsky, S. "A Characterization of Societies with Consistent Majority Decision," Review of Economic Studies, (197 ).

THE GEOMETRY OF PREFERENCE

AGGREGATION AND DOMAIN RESTRICTIONS

DISCUSSION PAPER #372

J.-M. Blin and Ram. T. S. Ramakrishnan

(Supplement: Figures)

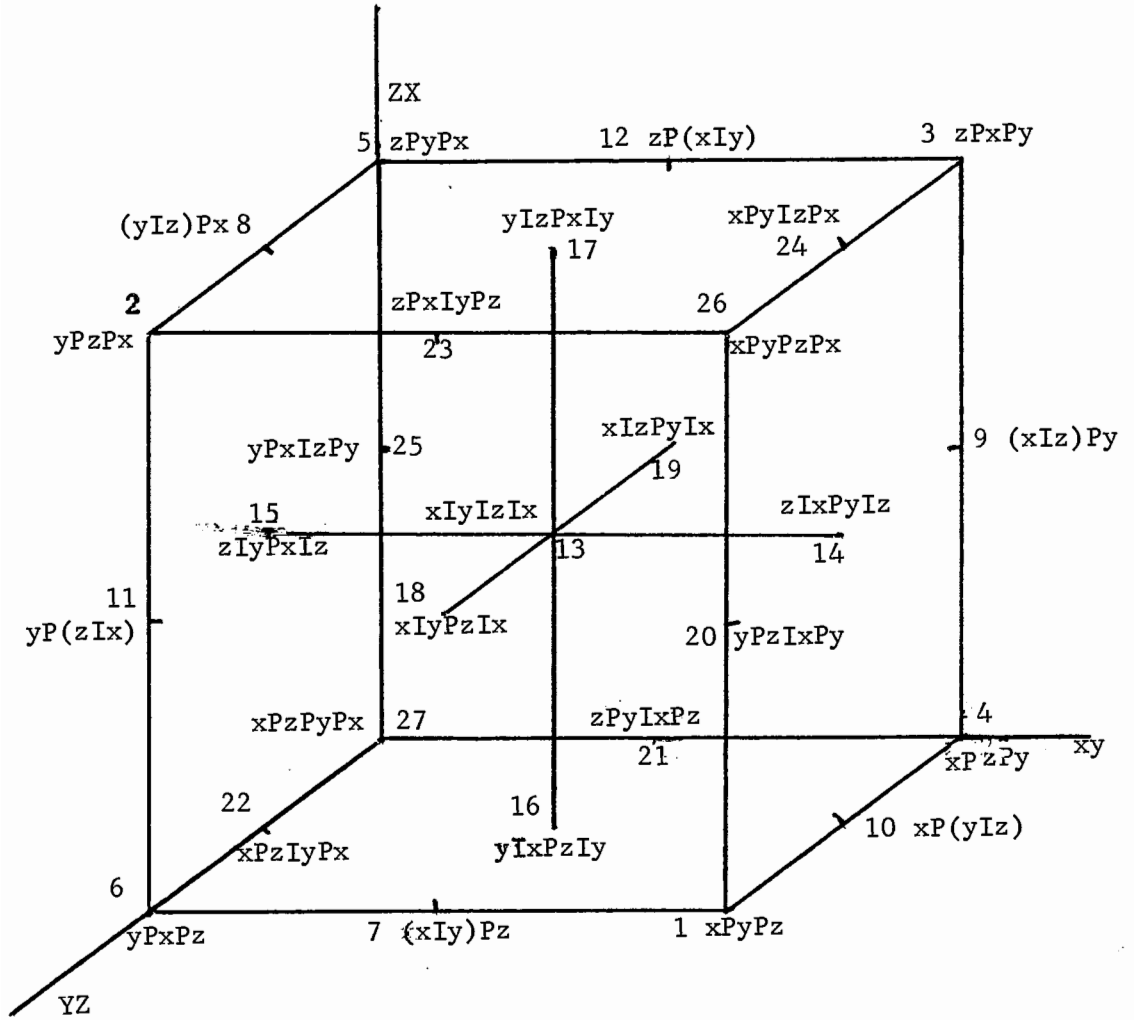

FIGURE 1

BINARY RELATIONS

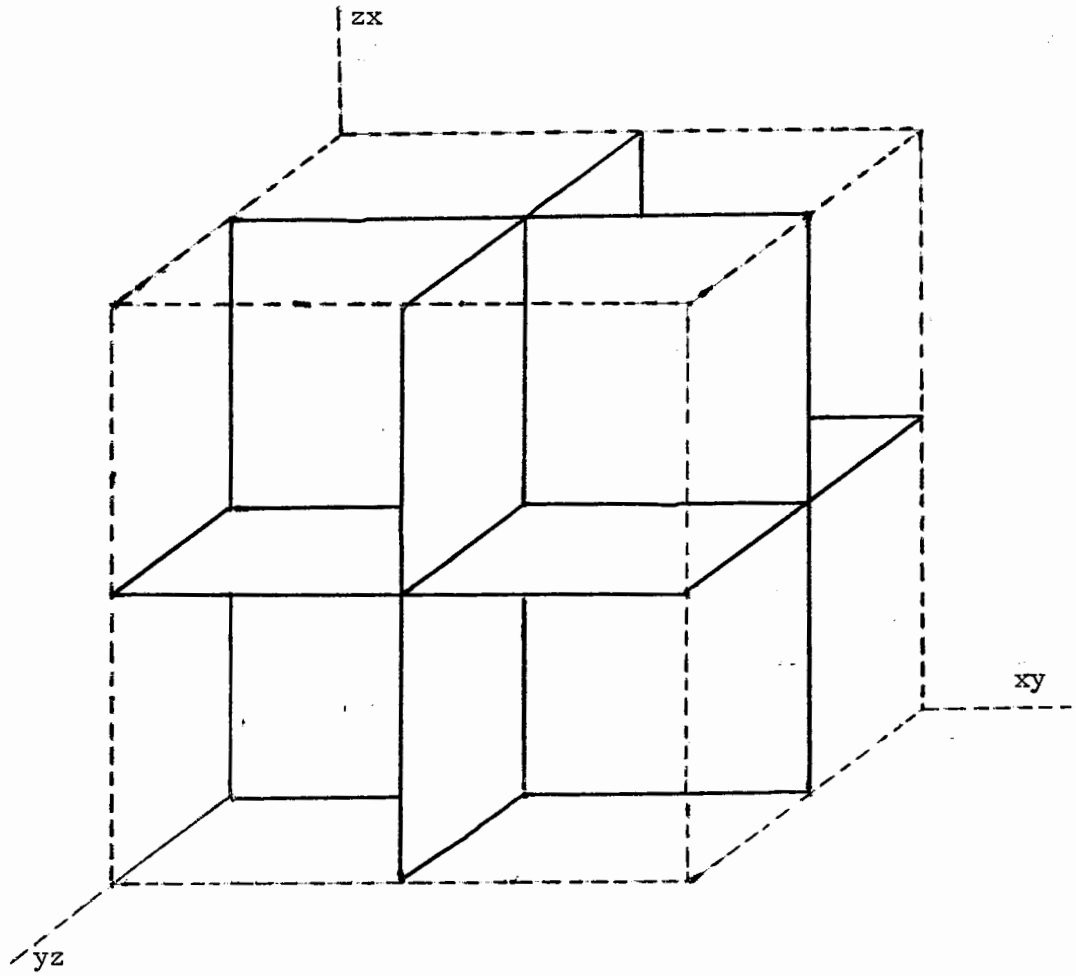

FIGURE 2  
REG(SI)

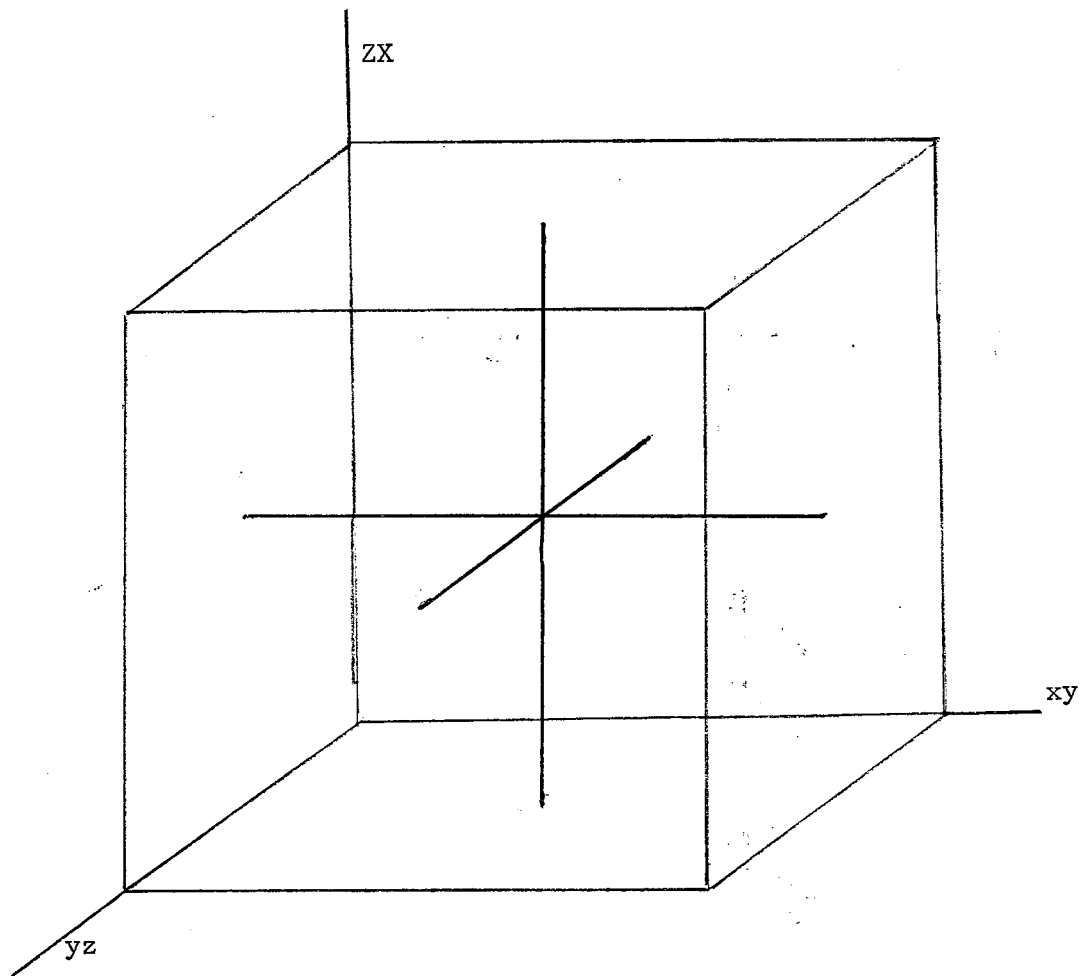

FIGURE 3  
REG(TI)

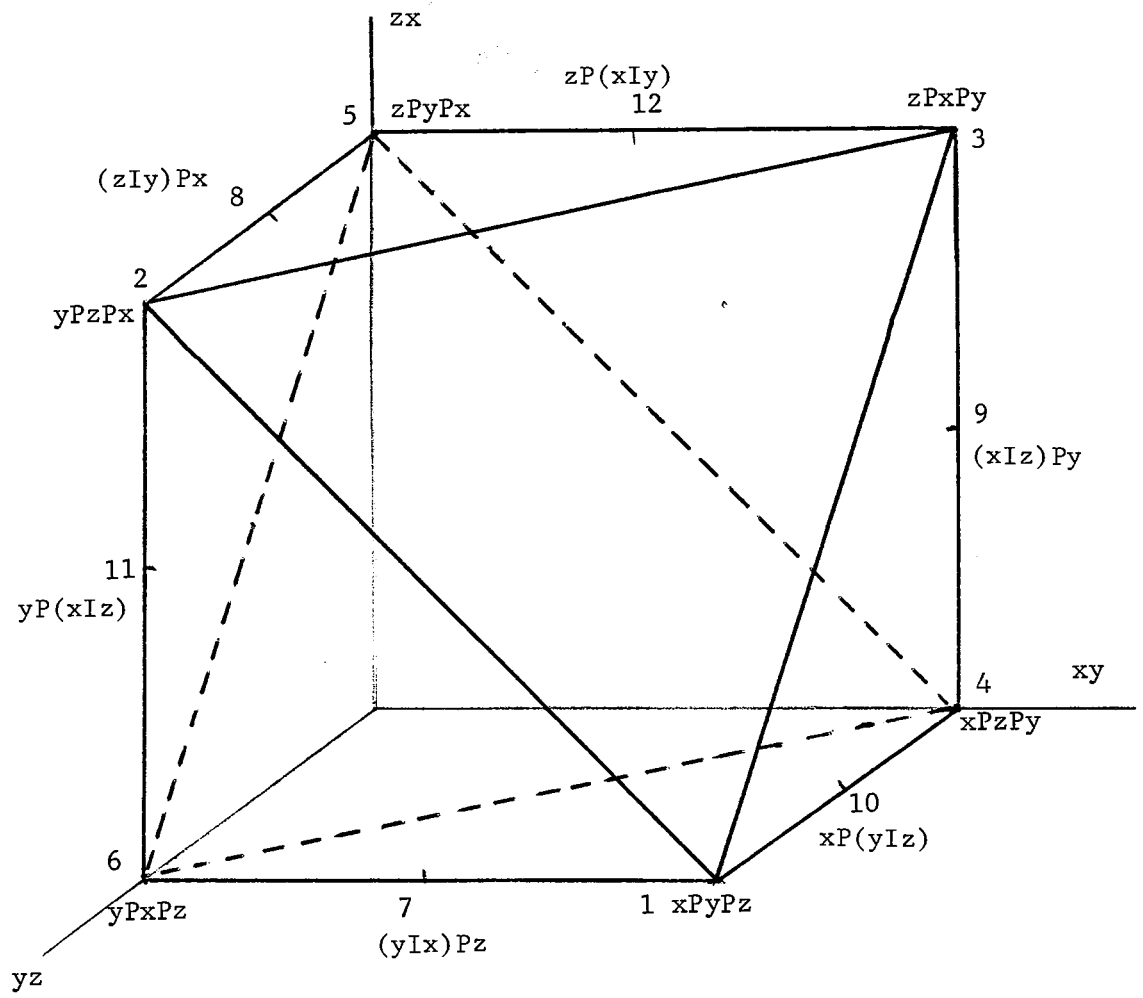

FIGURE 4

CV(TR)

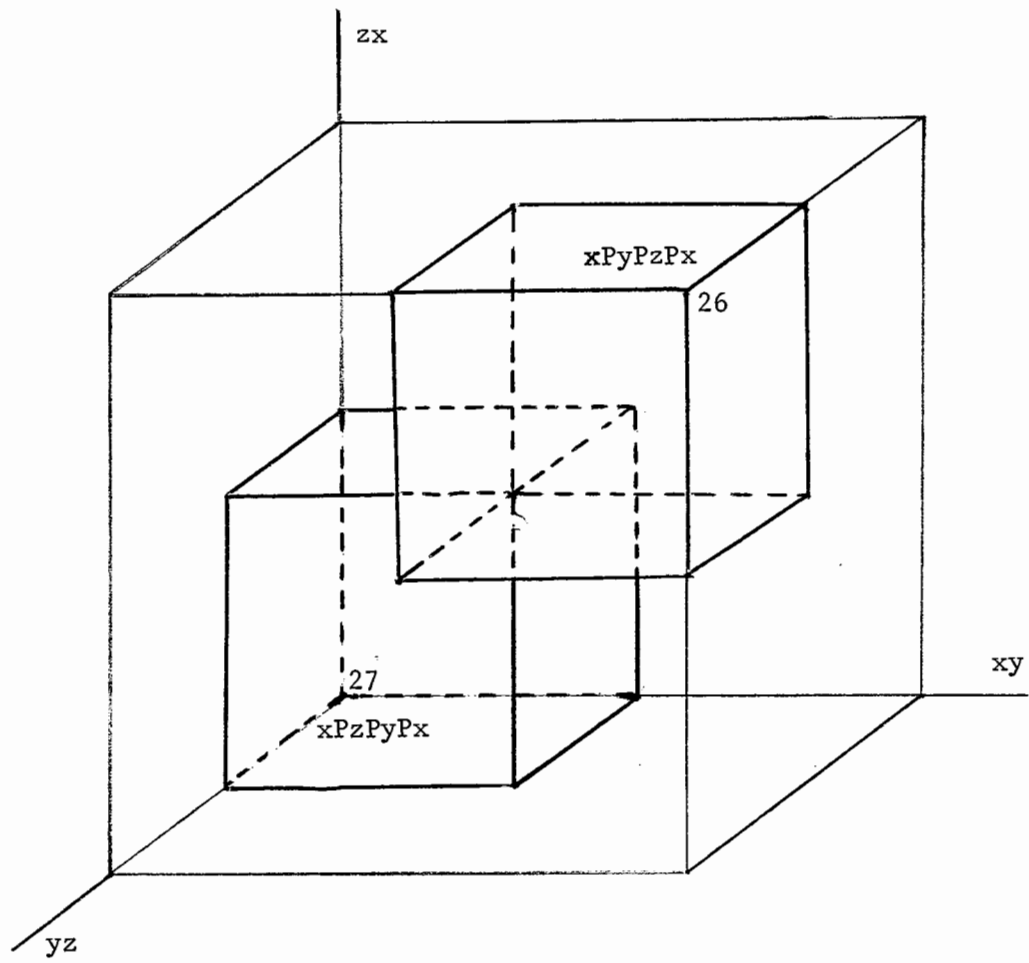

FIGURE 5

REG((CY) U (Z))







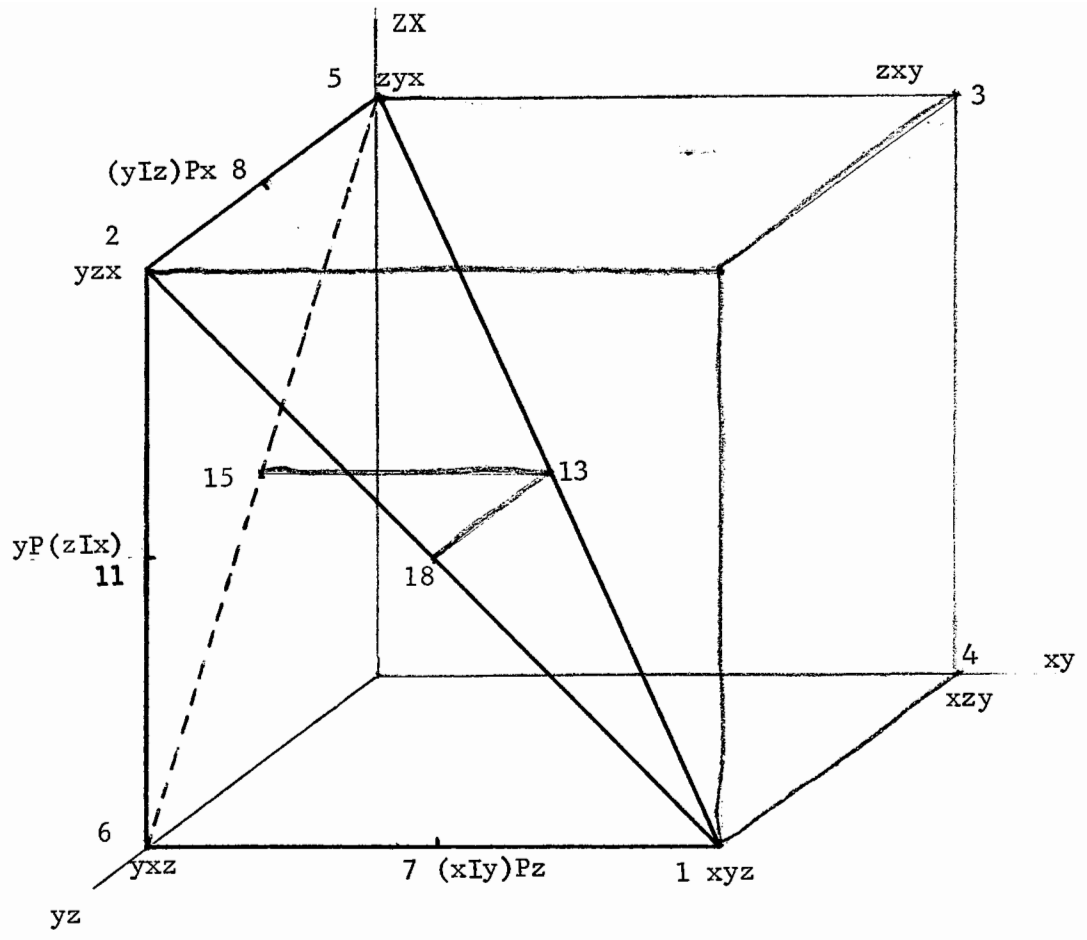

FIGURE 8

NL: NEVER LAST

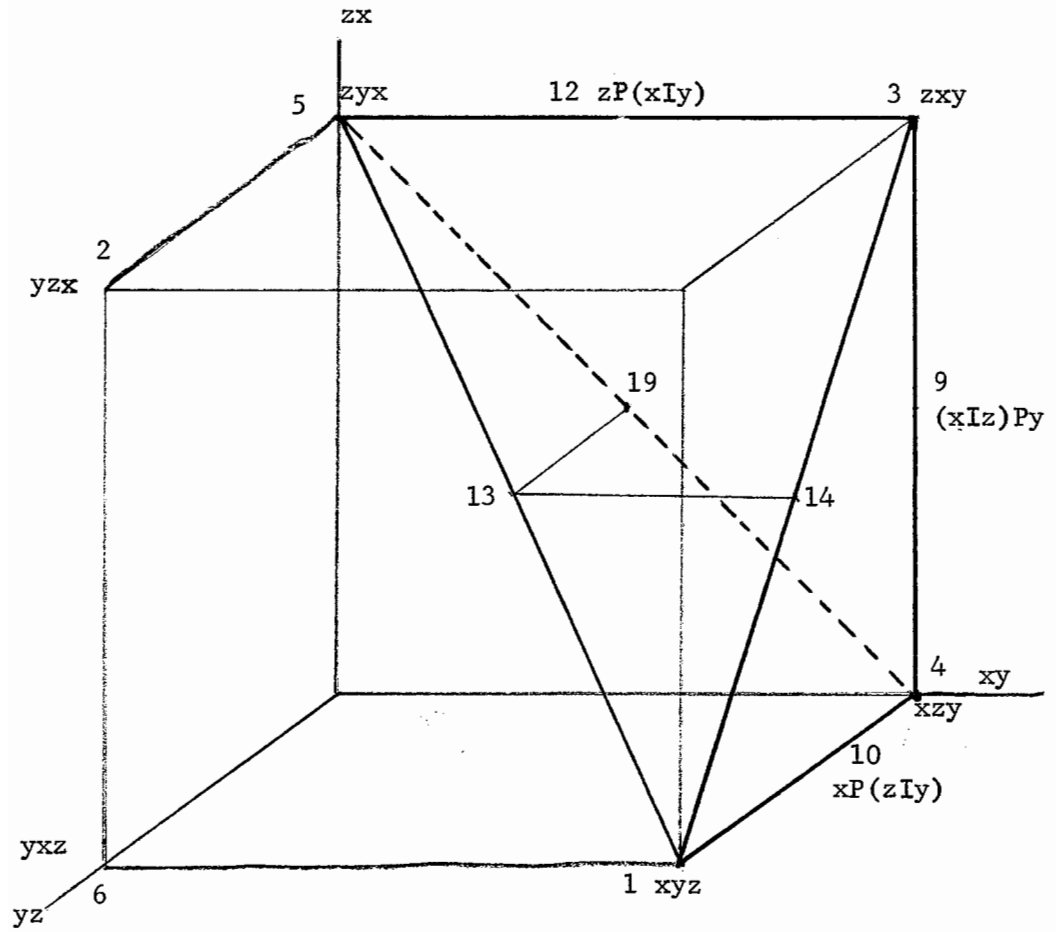

FIGURE 9  
 NF: NEVER FIRST

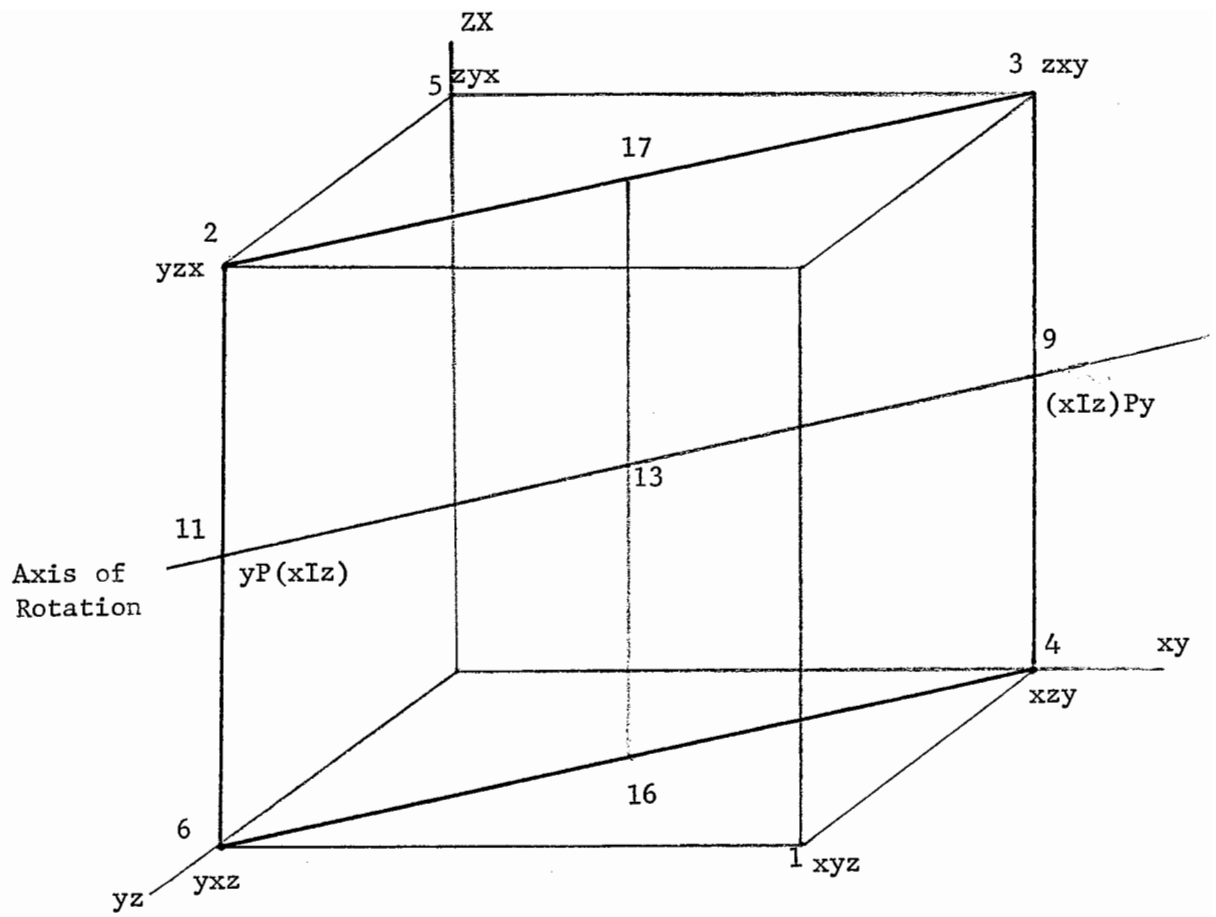

FIGURE 10

NM: NEVER MIDDLE

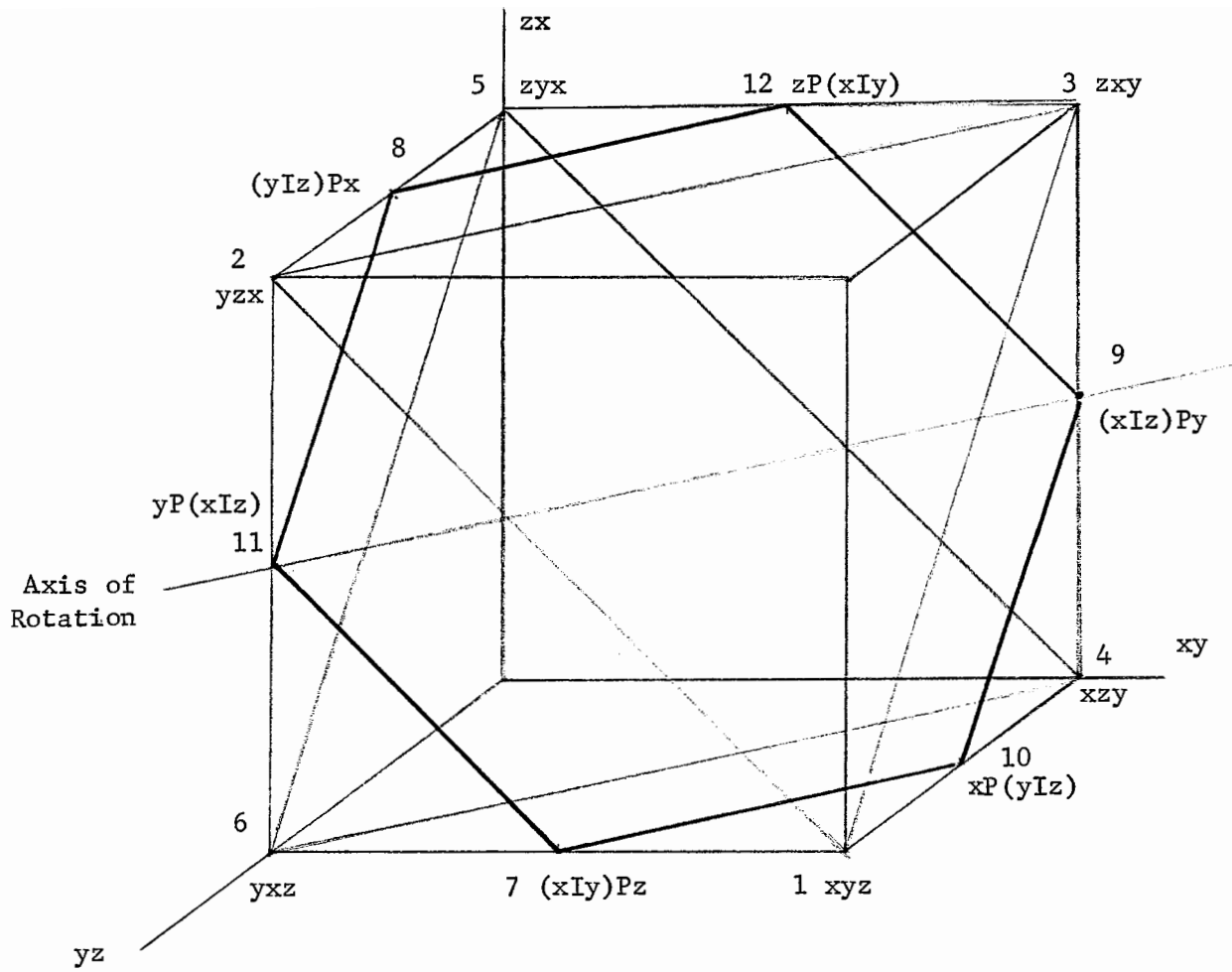

FIGURE 11

DP: DICHOTOMOUS PREFERENCES

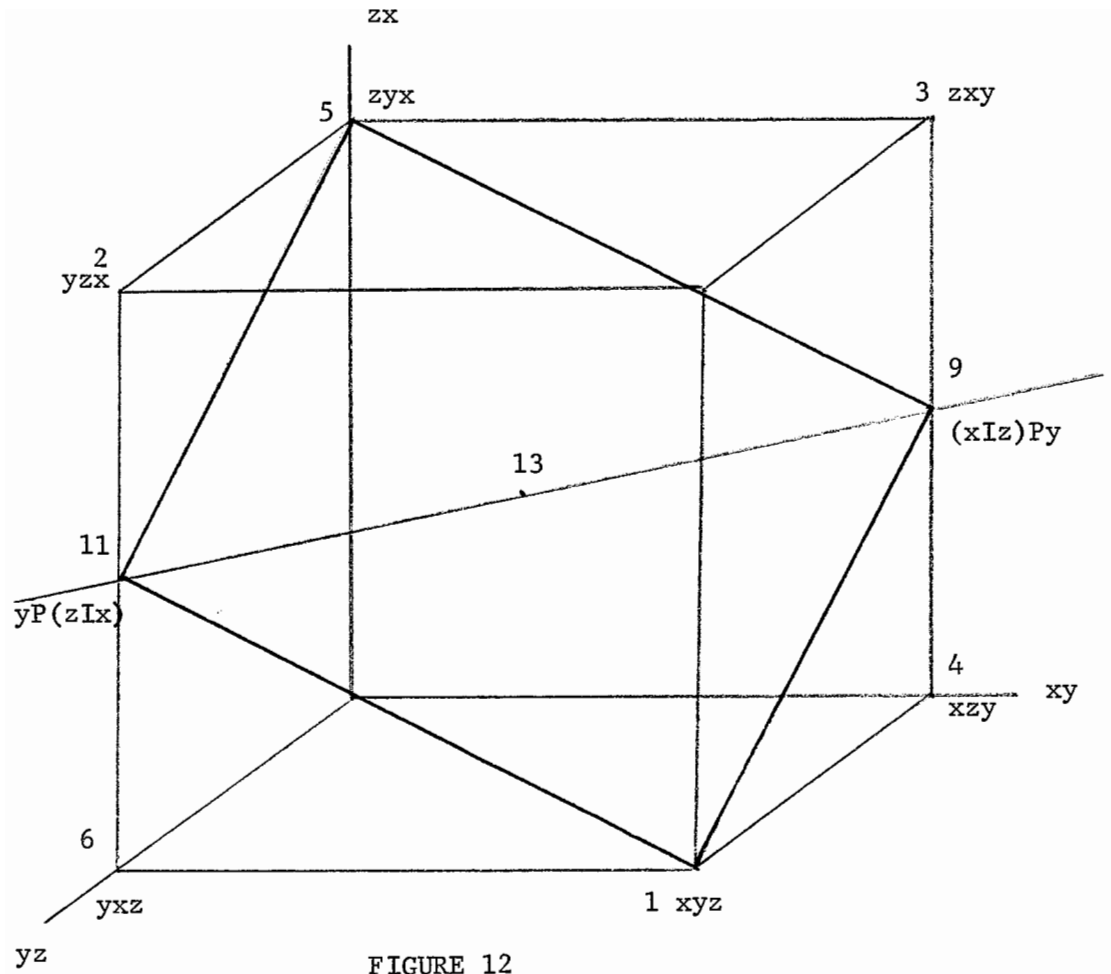

FIGURE 12  
 AP: ANTAGONISTIC PREFERENCES

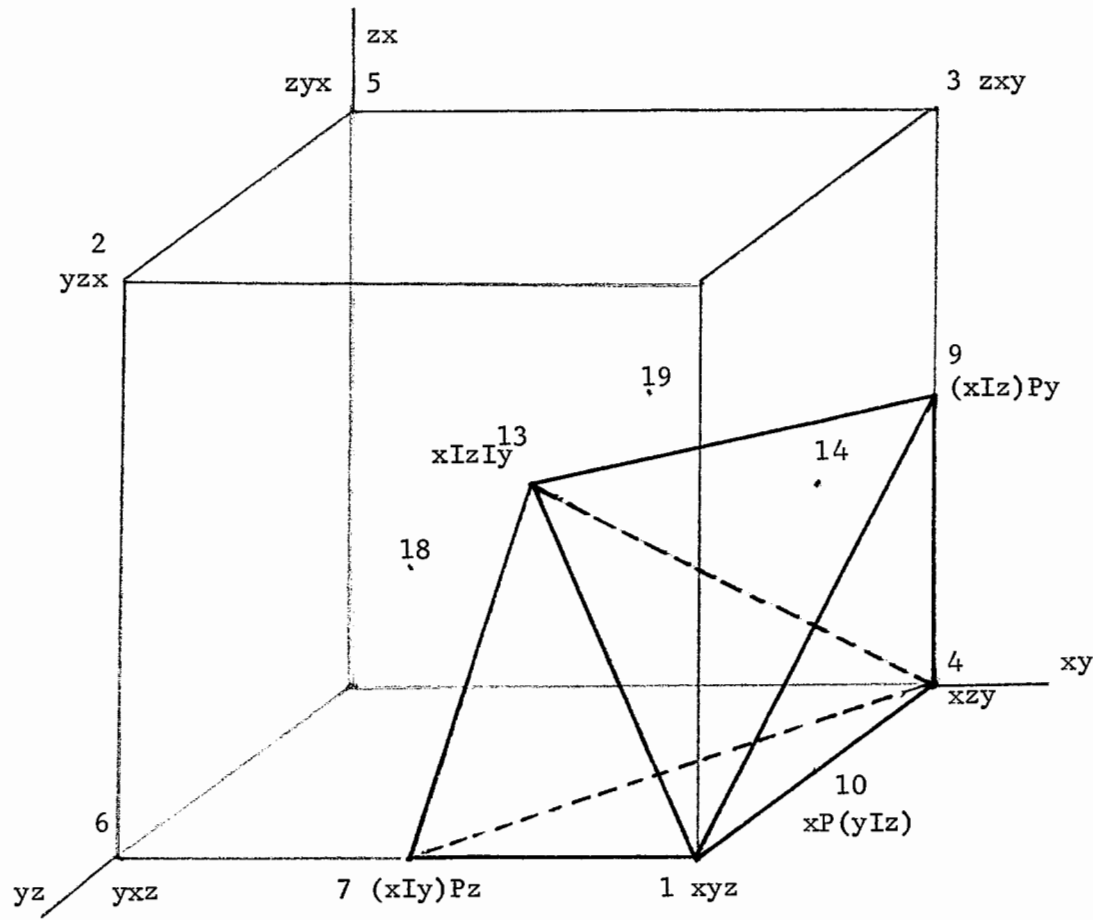

FIGURE 13

AF: ALWAYS FIRST



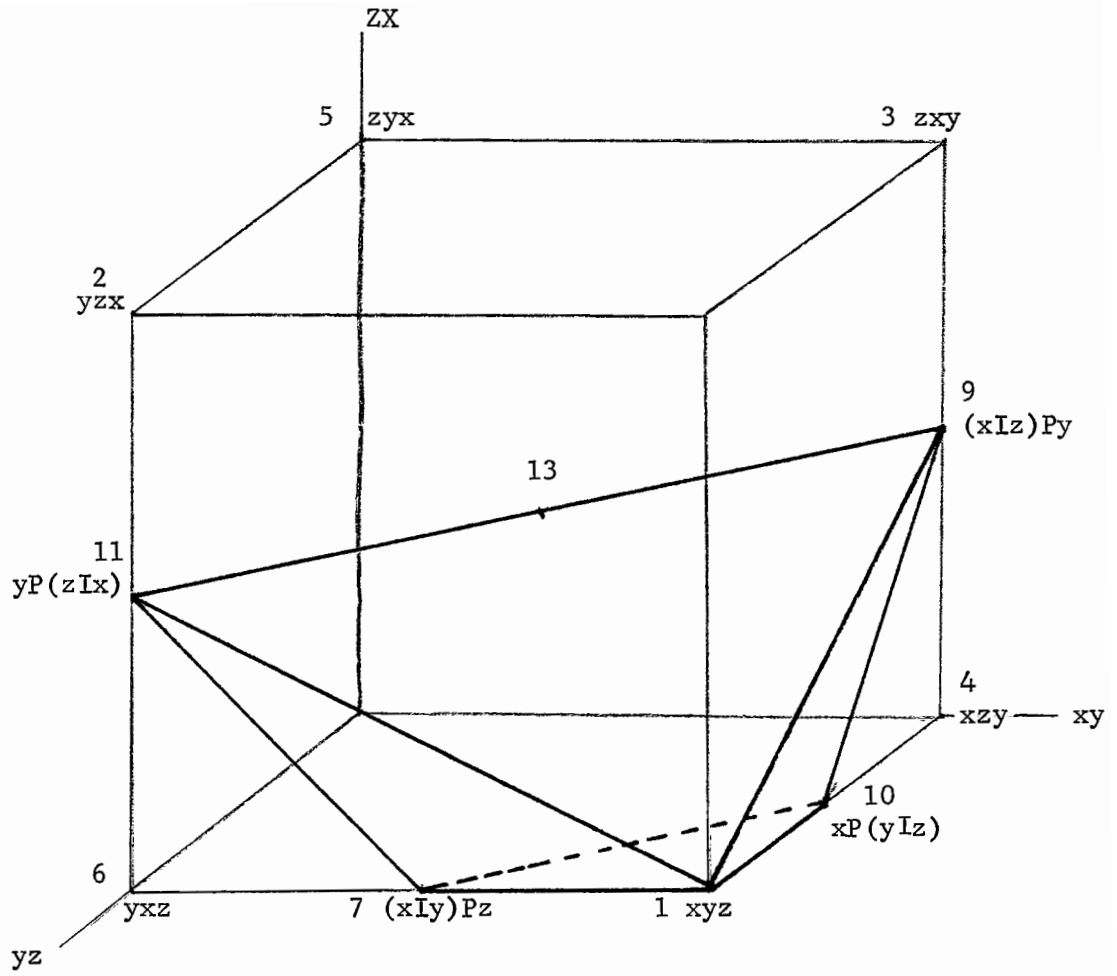

FIGURE 14  
 LA

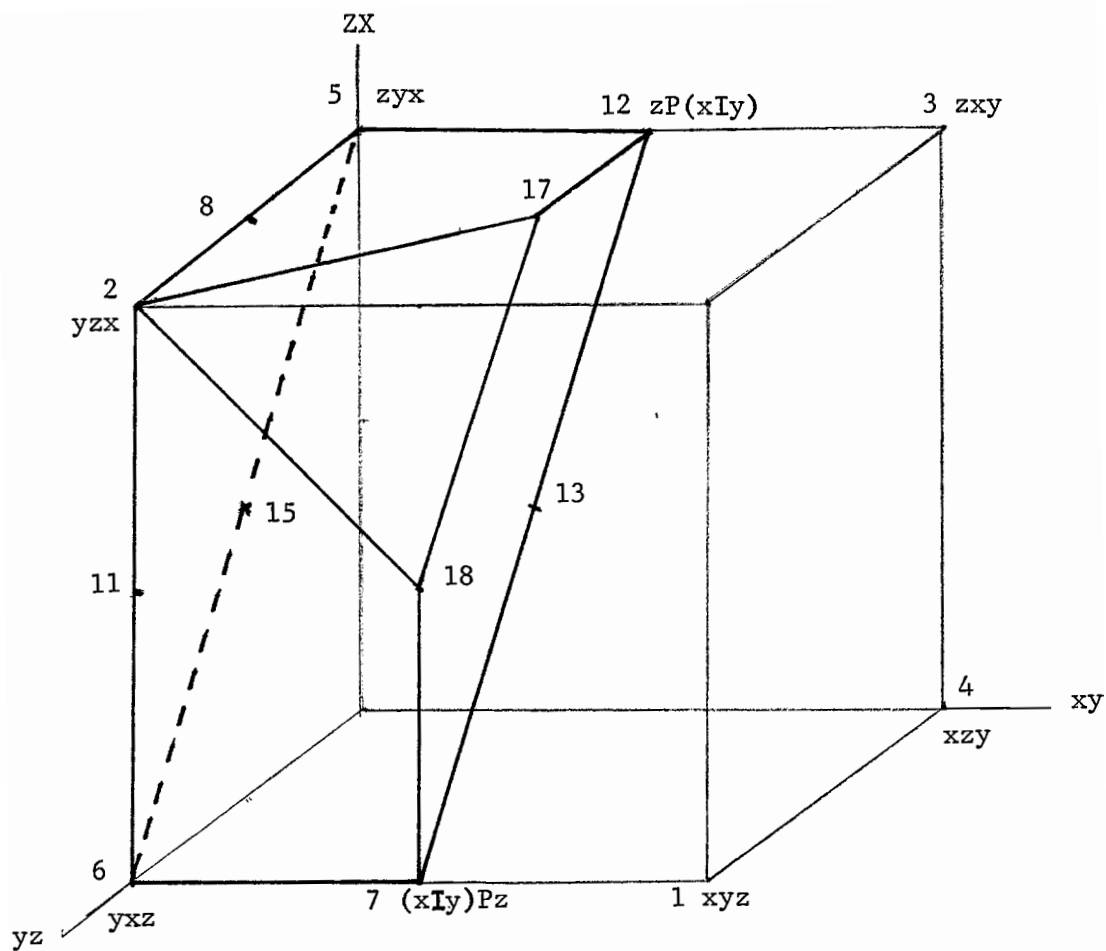

FIGURE 15

LAC

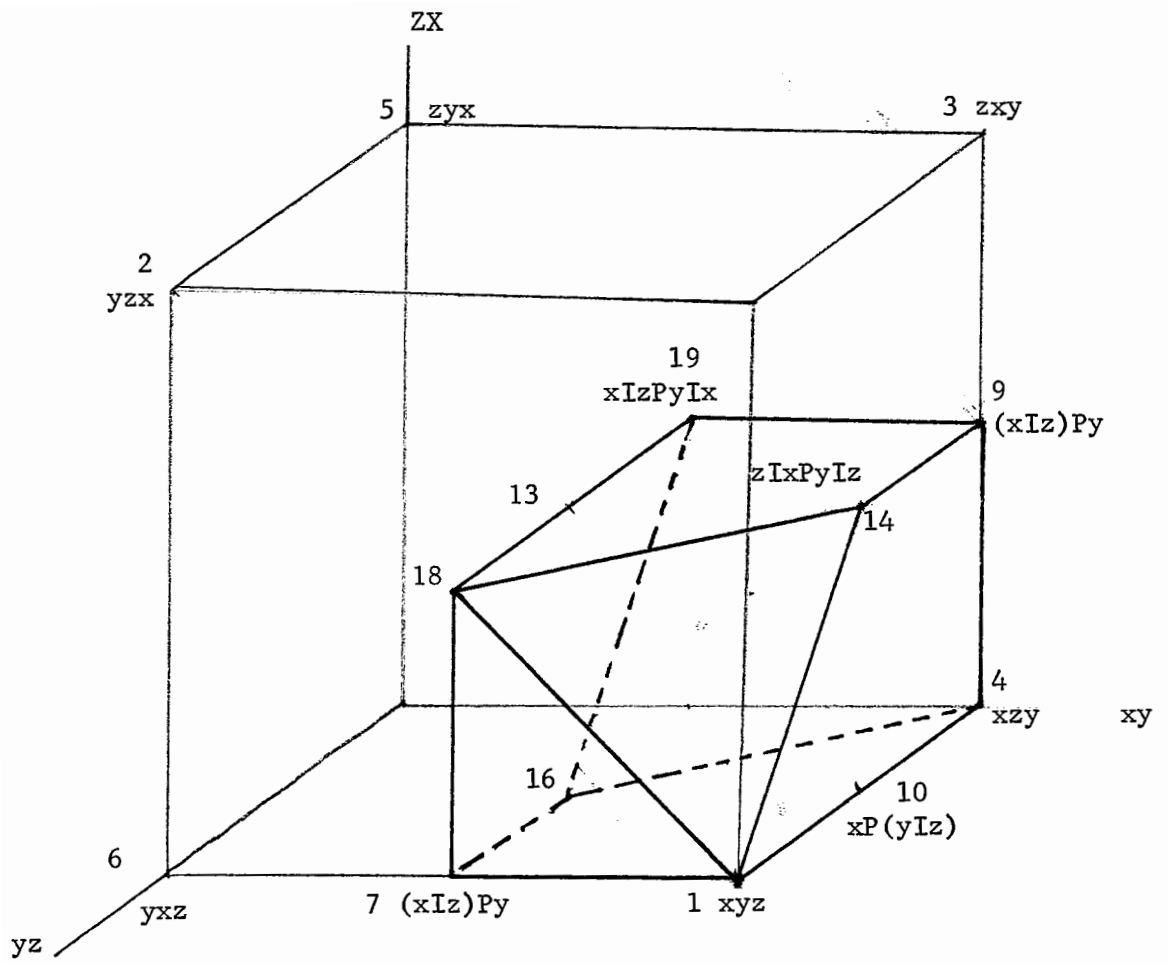

FIGURE 16

AFC

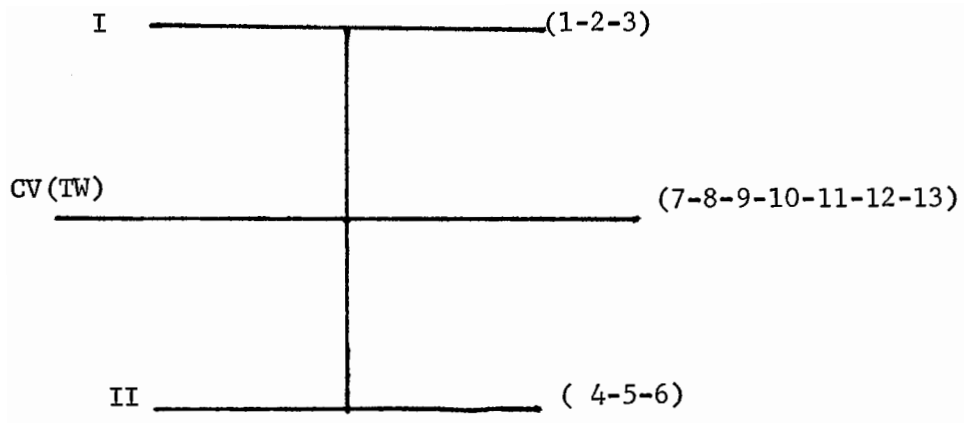

FIGURE 17  
 $N_I = N_{II}$

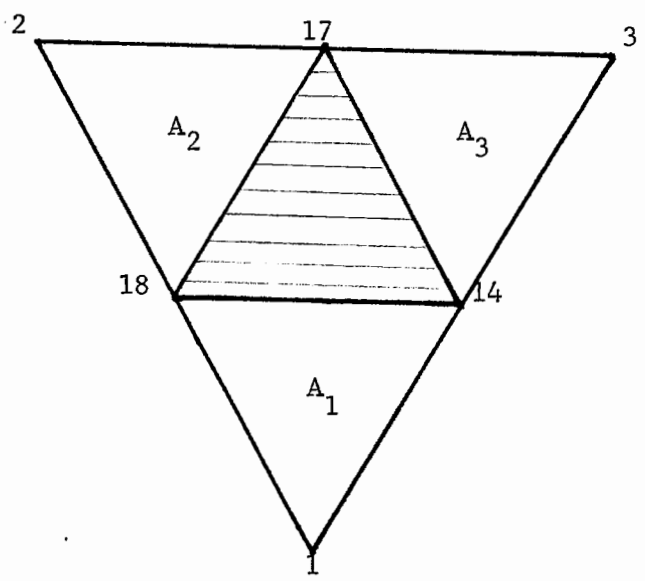

FIGURE 18