

Lautenbach, P.; Johnston, K.; Adeniran-Ogundipe, T.

## Article

# Factors influencing business intelligence and analytics usage extent in South African organisations

South African Journal of Business Management

## Provided in Cooperation with:

University of Stellenbosch Business School (USB), Bellville, South Africa

*Suggested Citation:* Lautenbach, P.; Johnston, K.; Adeniran-Ogundipe, T. (2017) : Factors influencing business intelligence and analytics usage extent in South African organisations, South African Journal of Business Management, ISSN 2078-5976, African Online Scientific Information Systems (AOSIS), Cape Town, Vol. 48, Iss. 3, pp. 23-33, <https://doi.org/10.4102/sajbm.v48i3.33>

This Version is available at:

<https://hdl.handle.net/10419/218644>

### Standard-Nutzungsbedingungen:

Die Dokumente auf EconStor dürfen zu eigenen wissenschaftlichen Zwecken und zum Privatgebrauch gespeichert und kopiert werden.

Sie dürfen die Dokumente nicht für öffentliche oder kommerzielle Zwecke vervielfältigen, öffentlich ausstellen, öffentlich zugänglich machen, vertreiben oder anderweitig nutzen.

Sofern die Verfasser die Dokumente unter Open-Content-Lizenzen (insbesondere CC-Lizenzen) zur Verfügung gestellt haben sollten, gelten abweichend von diesen Nutzungsbedingungen die in der dort genannten Lizenz gewährten Nutzungsrechte.

### Terms of use:

*Documents in EconStor may be saved and copied for your personal and scholarly purposes.*

*You are not to copy documents for public or commercial purposes, to exhibit the documents publicly, to make them publicly available on the internet, or to distribute or otherwise use the documents in public.*

*If the documents have been made available under an Open Content Licence (especially Creative Commons Licences), you may exercise further usage rights as specified in the indicated licence.*



<https://creativecommons.org/licenses/by/4.0/>

# Factors influencing business intelligence and analytics usage extent in South African organisations

P. Lautenbach, K. Johnston\* and T. Adeniran-Ogundipe

Department of Information Systems, University of Cape Town, Private Bag, Rondebosch, 7701, South Africa

\*To whom all correspondence should be addressed  
kevin.johnston@uct.ac.za

Through extensive use of business intelligence and analytics, organisations are better positioned to support fact-based decision making, ultimately leading to improved organisational performance. However, while some organisations recognise and exploit the benefits of business intelligence and analytics use, others fail to capitalise on its potential. It is pertinent therefore to examine factors influencing Business Intelligence and Analytics use within organisations. The three contexts of the Technology-Organisation-Environment (TOE) framework was used as the foundational framework. It is hoped that the findings presented will contribute to a greater understanding of factors influencing business intelligence and analytics usage extent to researchers and practitioners alike. Organisations seeking to promote fact-based decision making through greater business intelligence and analytics use will apply and be better equipped to drive such endeavours.

## Introduction

Organisations are constantly looking to get value out of their growing data assets to gain or maintain competitive advantages. Through the successful use of Business Intelligence and Analytics (BI&A), organisations can harvest and extract greater value from their data assets, thus more likely able to outperform their competitors (LaValle, Lesser, Shockley, Hopkins & Kruschwitz, 2011; Sidorova & Torres, 2015). Analysis of data through the use of BI&A tools and techniques allows organisations to gain insights into key areas to drive effective decision making (Chaudhuri, Dayal & Narasayya, 2011; Rouhani, Ashrafi, Zare & Afshari, 2016; Shollo & Galliers, 2015). LaValle *et al.* (2011) concluded that higher performing organisations are twice as likely to use analytics whether it be for growth, efficiency or competitive advantage purposes.

A survey conducted by MIT's Sloan Management Review, in partnership with the IBM Institute for Business Value in 2011 showed that the number of organisations wishing to differentiate themselves from their competitors through the use of analytics is on the increase (Kiron & Shockley, 2011). This is indicative of the strategic importance that organisations are placing on BI&A usage. Not only is the use of BI&A strategic, but it is increasingly becoming a necessity and no longer a nice *to have* to remain competitive in the market (Davenport, 2013b; Zikopoulos, deRoos, Parasuraman, Deutsch, Giles & Corrigan, 2013). Pettey and van der Meulen (2013) revealed that both Business Intelligence (BI) and analytics initiatives remain top of CIO's listed technical priorities. Now, implementing analytics and Big Data is in the top ten priorities of the business. The importance organisations continue to place on the strategic use of BI&A remain high as is the traction that big data

analytics is gaining on the CIO agenda (Luftman, Zadeh, Derksen, Santana, Rigoni & Huang, 2013).

Executives and organisational decision-makers have recognised the importance of informed data-driven decision making as opposed to intuition-based decision making and are progressively wanting to manage their organisations in this manner (LaValle *et al.*, 2011; McAfee & Brynjolfsson, 2012; Rouhani *et al.*, 2016). The benefits of data-driven decision making are both improved productivity and market value, as was empirically shown in a study by Brynjolfsson, Hitt and Kim (2011) who concluded that organisations who adopted data-driven decision-making practices showed 5-6% higher productivity rates. BI&A practices and tools are seen as key enablers of data-driven decision making and provide the framework and support for organisations wanting to make better fact-based decisions (Davenport & Dyché, 2013; Shollo & Galliers, 2015; Wixom & Watson, 2010).

Although the benefits of successful BI&A implementations are apparent, review of the literature posits that the actual extent of use of BI&A within organisations is low (Malladi & Krishnan, 2013; Shollo & Galliers, 2015; Yeoh & Popovič, 2015). Though some organisations are using BI&A extensively within their organisations to support fact-based decision making, Malladi and Krishnan (2013: 2) assert: "it is unclear what differentiates firms in extensively using BIA in business activities." While some organisations have been successful in their BI&A implementations being able to show real derived benefits, others fail to realise such benefits (Ramakrishnan, Jones & Sidorova, 2012; Sidorova & Torres, 2015; Yeoh & Popovič, 2015).

It is pertinent therefore to examine factors influencing the use of BI&A within organisations. Given the importance of data-

driven decision making and the value proposition of the successful implementation and use of BI&A to support such decisions, this study seeks to answer: What factors influence BI&A usage extent within South African organisations?

It is hoped that the findings presented in this study will be of benefit to practitioners of BI&A by assisting them in their understanding of influential BI&A usage factors as well as to academics by contributing to the existing body of knowledge in the information systems (IS) and information technology (IT) domains.

## Literature review

### Business intelligence and analytics (BI&A)

The term “Business Intelligence” (BI) was popularised during the 1990’s, and could be considered as a term that “encompasses a wide variety of processes and software used to collect, analyse, and disseminate data, all in the interest of better decision making” (Davenport, 2006: 8). Wixom and Watson (2010: 13) acknowledge that BI “is an umbrella term that is commonly used to describe the technologies, applications, and processes for gathering, storing, accessing, and analysing data to help users make better decisions”. Business analytics (BA) can also be thought of as the analytical component of BI (Chen, Chiang & Storey, 2012). The literature appears to at times use BI and BA interchangeably (Davenport, 2006). While data mining is considered part of BA, this technology enables “automatic extraction of patterns, associations, changes, anomalies and significant structures from data” (Bose, 2009: 156) thereby creating predictive models for use in decision making. This process has been more recently referred to as predictive analytics and uses algorithms and statistical techniques to extrapolate future events (Bose, 2009).

The tangible benefits that an organisation can derive through the use of BI&A are hard to quantify (Watson & Wixom, 2007), and many of the benefits provided are “long-term, indirect and difficult to measure” (Popovič, Hackney, Coelho & Jaklič, 2012: 729). However, it is widely stated in the literature that the value of BI&A is that it enables organisations to gain better visibility into their data which in turn leads to improved decision-making processes and consequently better data-driven decision making (LaValle *et al.*, 2011; McAfee & Brynjolfsson, 2012; Negash, 2004; Popovič *et al.*, 2012; Seddon, Constantinidis & Dod, 2012; Watson & Wixom, 2007; Yeoh & Popovič, 2015). And while data-driven decision-making benefits are difficult to quantify, an empirical study by Brynjolfsson *et al.* (2011) concluded that organisations who adopt data-driven decision-making practices show 5-6% higher productivity rates.

Watson and Wixom (2007) argued that some BI benefits are easier to measure than others. Benefits that are easier to measure are at operational levels in organisations while benefits at strategic levels, which are broader in scope, are harder to measure. Increasingly, organisations realise the need to focus on organisational core capabilities, and BI&A organisational capabilities are being seen as a driver of

competitive advantage (Aulkemeier, Paramartha, Iacob & van Hillegersberg, 2015; Davenport, 2013a). Organisations on the path to increased BI&A maturity realise that BI&A practices, tools and techniques can provide a key strategic advantage over competitors. Making better use of BI&A is being driven by the need to remain competitive (Bose, 2009; Kiron & Shockley, 2011). Bose (2009) argued that as organisations evolve and mature in their use of BI&A, they begin to move towards using advanced analytics for supporting decision making which in turn leads to competitive advantage. Furthermore, Davenport (2006) argued that in a competitive marketplace, organisations making extensive use of analytical capabilities – termed “analytics competitors” – differentiate themselves and are the leaders in their respective market segments. Still, organisations that have reached a level of analytical capability that differentiates them in the market are in the minority (Davenport, 2006).

The implementations of BI&A within organisations are viewed as difficult and challenging because they extend beyond simple software and hardware implementations and are more complicated to deploy and run. BI&A implementation projects are complex and often involve lengthy integration processes. The integration of data from many underlying source systems that feed data into the Data Warehousing (DW) can be diverse in nature and contain data in different formats. Data can be sourced from either internal transactional databases or external data and the effort required to succeed in this complex undertaking is often underestimated (Ramamurthy, Sen & Sinha, 2008; Yeoh & Koronios, 2010).

Organisations are guilty of underestimating the time and effort required to gather, clean and organise the data into usable formats. “Data issues are typically the leading cause of failure and the most costly element of BI implementations” (Mungree, Rudra & Morien, 2013: 3). Data quality challenges are cited as being the highest technical challenge that BI&A implementations face (Malladi & Krishnan, 2013). Importantly, Popovič *et al.* (2012) found that better information content quality leads to the greater use of information in business processes. The quality of the data that is available in BI&A implementations is of utmost importance as poor quality data renders BI&A essentially ineffective within organisations (Bose, 2009).

Using BI&A successfully is more than just about implementing and utilising technology and resolving BI&A data quality issues, as well as technical implementation challenges (Yeoh & Popovič, 2015). There are also organisational and managerial challenges (Yeoh & Popovič, 2015). BI&A needs to be approached in a holistic and strategic manner within organisations and needs the buy-in and support of executives and management (Luftman, Derksen, Dwived, Santana, Zadeh & Rigoni, 2015). It has been highlighted that success in BI&A endeavours requires the involvement and support of top management and executives and that organisations who encourage a culture of fact-based decision making are more likely to succeed (Bijker & Hart, 2013; Luftman *et al.*, 2015; Mungree *et al.*, 2013;

Ramamurthy *et al.*, 2008; Yeoh & Koronios, 2010; Yeoh & Popovič, 2015). Popovič *et al.* (2012) further underline the important role that a fact-based decision-making culture has on BI systems success within organisations, which is one of the key drivers of BI&A systems usage.

## BI&A maturity models

Maturity models exist to help organisations understand, assess and measure their maturity in a particular domain and highlight areas of strength as well as areas where improvements can be made (Lahrmann, Marx, Winter & Wortmann, 2011). Increased maturity in BI&A means the greater extent of use of the technologies at play, increasing individual and organisational impact and enhanced business value, hence increased return on investment (Hribar Rajterič, 2010; Lahrmann *et al.*, 2011). Maturity models assess a company's stage or level of maturity and map the way forward for them to mature, move or evolve to the next level.

Hribar Rajterič (2010) assert that for an organisation to attain a more accurate view of their BI&A maturity, they are best advised to use a combination of maturity models as they each have various emphases. There exist several maturity models for BI, of which four are briefly discussed below:

### *The data warehousing institutes (TDWI) BI maturity model*

Eckerson (2007) outlines six stages of BI development through which an organisation will move on their BI&A maturity growth path, namely "pre-natal and infant", through "child and teenager", to "adult and sage". Eckerson (2007) outlines various characteristics of each stage reflecting an organisations capability on such dimensions as infrastructure architecture, type of analytical tool use, executive perceptions as to the value and use of BI and type of system application within the organisation. Also reflected in this model is the notion that return on investment (ROI) increases as organisations maturity in BI&A capabilities grows (Eckerson, 2007)

### *The ladder of BI (LOBI) maturity model*

Cates, Gill and Zeituny (2005) proposed that maturity is evaluated against the efficacy and efficiency of organisational decision-making processes, and an organisation is rated on a six scale ladder.

### *Gartner's maturity model for BI and performance management (PM)*

Gartner's model has five generically labelled levels of maturity that are not given specific dimensions but rather are described textually (Hribar Rajterič, 2010). The model posits that organisations reach a pervasive level of maturity when: information is trusted throughout the organisation; BI&A is used extensively both inside the organisation, and this use has extended to external business partners; BI&A are used widely in business processes. The framework also provides useful

practical guidelines for organisations which can help them both assess their current maturity level as well as assist with mapping out future improvements (Hribar Rajterič, 2010).

### *Impact-oriented BI maturity model*

Lahrmann *et al.* (2011) highlighted that gaps exist in BI maturity models and that they are not necessarily based on sound theoretical foundations. Consequentially, Lahrmann *et al.* (2011) developed an impact-oriented BI Maturity Model; wherein maturity is evaluated based on the impact that BI&A has on overall organisational success and assert that successful deployment and usage of BI&A leads to better decisions thereby impacting and contributing to organisational performance. Importantly, Lahrmann *et al.* (2011: 7) conclude: "we empirically derived that financial and general support for BI by management and business functions have a positive impact on the overall organizational performance".

These maturity models that may influence BI&A usage extent present factors for consideration in this research study such as infrastructure capabilities, management support as well as other organisational and environmental factors.

## Theoretical frameworks

Some theoretical frameworks, such as Diffusion of innovation, Model of IS success, and Technology-Organisation-Environment have been used in research studies to understand IT adoption at the organisational level. These frameworks - as do the maturity models listed - typically outline and help to identify important adoption factors.

### *Diffusion of innovation theory - Rogers (1995)*

Rogers (1995) diffusion of innovation theory is a non-domain specific theory that has however been applied to the information systems context to understand technology adoption (Yi, Jackson, Park & Probst, 2006).

The theory categorises individuals into five adopter categories: innovators, early adopters, early majority, late majority, and laggards (Rogers, 1995).

The adoption rate of innovation is affected by five factors: relative advantage, compatibility, complexity, trialability and observability (Rogers, 1995).

An individual moves through five decision-making steps or stages in the adoption process: knowledge, persuasion, decision, implementation, and confirmation (Rogers, 1995).

Although the above points relate to the innovation process at an individual level, Rogers (1995) also proposed a diffusion of innovation theory at an organisational level, which is recognised as a more complex process. At an organisational level, variables such as "individual (leader) characteristics, internal organizational structural characteristics, and external characteristics of the organization" (Oliveira & Martins, 2011: 111) contribute to an organisations innovativeness.

### *Model of IS success - DeLone and McLean (1992, 2003)*

DeLone and McLean (1992) proposed a model outlining six, interrelated dimensions that impacted on information system success these being: system quality, information quality, use, user satisfaction, individual impact and organisational impact. This model was formulated and developed based on an extensive review of prior research literature (DeLone & McLean, 2003). However, based on feedback and a review of the models use over a period, the model was updated in 2003. This model shows the associated relationships between factors. An example of this is that 'information quality' may have either a positive or a negative influence on 'intention to use' and 'user satisfaction'.

DeLone and McLean (1992, 2003) models of IS success have been used extensively in IS research, and it is one of the most often used and cited frameworks for understanding IS adoption and success (Popovič *et al.*, 2012; Wieder & Ossimitz, 2013).

### *Technology-organisation-environment framework - Tornatzky and Fleischer (1990)*

In the Technology-Organisation-Environment (TOE) framework, Tornatzky and Fleischer (1990) proposed that there are Technological (existing and new technologies), Organisational (organisation size, scope, managerial structure) and Environment (industry competitors, industry size, regulatory environment) factors that impact an organisations adoption of an innovation or technology (Zhu, Kraemer & Xu, 2006). The TOE framework is a relatively broad framework that can be adapted according to the specifics of a particular domain within IS. For example, it has been used in empirical research to understand technology adoption in such domains as ERP, e-business, information and communication technology and EDI (Low, Chen & Wu, 2011; Masrek, Jamaludin & Hashim, 2009; Oliveira & Martins, 2011; Zhu *et al.*, 2006). TOE has also been used in prior studies to understand adoption factors specific to the BI domain (Bijker & Hart, 2013; Malladi & Krishnan, 2013)

Furthermore, the TOE framework has a strong theoretical grounding and as is evident from the literature, has been widely used in empirical research (Low *et al.*, 2011). Consistent also with Rogers (1995) diffusion of innovation theory, TOE extends this framework by adding the environmental aspects and could be considered as more comprehensive (Low *et al.*, 2011; Oliveira & Martins, 2011). The TOE framework is therefore considered a good fit for this study for two reasons. First, the TOE framework has been used in previous empirical studies to understand BI&A usage extent, adoption and pervasiveness (Bijker & Hart, 2013; Malladi & Krishnan, 2013) and second, TOE is easily adapted to include appropriate factors within the three contexts of technology, organisation and environment.

With the above mentioned BI&A specific maturity models and the TOE framework in mind, some factors specific to

BI&A usage extent that falls within the TOE framework are now presented and discussed:

## **Technological context**

### *Data-related infrastructure capabilities*

Organisations that have strong supportive data-related infrastructures are better positioned to extensively use BI&A (Zhu *et al.*, 2006). Huang, Liu and Chang (2012) suggest that to affectively use data mining tools (DMTs), there needs to be in place a solid data infrastructure platform as it is an important element to successful data mining and that a vital enabler for BI&A use is a data warehouse. On review of existing BI maturity models, Lahrman *et al.* (2011) note that many of them consider data infrastructure capabilities as an element of maturity. Supportive BI&A data infrastructure requires the integration of underlying data, and can be considered a complex undertaking and better data infrastructure capabilities reflect an organisations readiness and ability to use BI&A (Elbashir, Collier & Sutton, 2011). Therefore, the researcher hypothesises the following:

*H1: Data-related infrastructure capabilities of will positively influence BI&A usage extent.*

### *Data management challenges*

One of the challenges facing BI&A usage extent is that of data management. Fundamental to data usage and consumption within the BI&A domain is that the data is reliable, complete, timely, consistent and accurate (Mungree *et al.*, 2013; Ramamurthy *et al.*, 2008; Yeoh & Koronios, 2010). "...findings indicate that the quality of data, particularly in the source systems, is crucial if a BI system is to be implemented successfully" (Yeoh & Koronios, 2010: 28). Without this, BI&A usage is hampered and limited as users and decision makers alike lose trust in the data (Kwon, Lee & Shin, 2014). However, the task of ensuring data quality is a complex undertaking and requires a sustained effort (Yeoh & Koronios, 2010). Therefore, the researcher hypothesises the following:

*H2: Data quality and data management challenges will negatively influence BI&A usage extent.*

## **Organisational context**

### *Top management support*

Top management support is highly ranked as a critical success factor (CSF) for BI&A (Bijker & Hart, 2013; Dawson & van Belle, 2013; Watson & Wixom, 2007). However, while top management support is important to successful BI&A adoption, LaValle *et al.* (2011) argue that it is also one of the biggest obstacles to BI&A usage. Organisational top level management needs to target BI&A usage strategically to derive maximum benefits (Watson & Wixom, 2007). Besides, BI&A needs to be driven from the highest levels within organisations, and failure to do so renders BI&A initiatives unable to reach full potential (LaValle *et al.*, 2011). Top

management support helps drive BI&A usage by managing change processes, acquiring necessary resources and aiding collaboration between business units (Mungree *et al.*, 2013; Luftman *et al.*, 2015). Therefore, the researcher hypothesises the following:

*H3: Increased top management support will positively influence BI&A usage extent.*

**Talent management challenges**

To implement BI&A effectively, a combination of business, as well as technical know-how, are considered important (Yeoh & Koronios, 2010). However, professionals who have the required set of skills, particularly the analytical capabilities required to derive value out of large sets of unstructured data are rare (Davenport & Patil, 2012; McAfee & Brynjolfsson, 2012). The following hypothesis is therefore proposed by the researcher:

*H4: Talent management challenges will negatively influence BI&A usage extent.*

**Environmental context**

*External market influence*

Organisations faced with competitive pressures are likely to respond strategically in different ways. For example, organisations may respond to these pressures by launching new products or services or expanding operations to differentiate themselves in the market or gain market share. Organisations can however also utilise technologies such as data warehouses and BI&A deployments as strategic initiatives to compete against rivals (Ramakrishnan *et al.*, 2012). Masrek *et al.* (2009) suggest that organisations facing competitive pressures and environment uncertainties "engage in greater sensing and search" activities to better understand both their internal activities as well as those of the marketplace. The sensing and searching may be helped

through the strategic use of BI&A. Malladi and Krishnan (2013) assert that organisations operating in competitive environments have higher information technology (IT) use and Davenport (2006) suggests that BI&A can be used by organisations to differentiate themselves from competitors. Pressures from competitors and the external environment are likely drivers of BI&A usage extent. Therefore, the researcher hypothesises the following:

*H5: External market factors and competitive intensity positively influence BI&A usage extent.*

**Regulatory compliance**

Regulatory compliance requirements place mandates on organisations and requires them to report accurate information to the market (Ramakrishnan *et al.*, 2012). For example, in the U.S., the Sarbanes–Oxley Act (SOX) requires organisations to meet specific financial reporting requirements (Ramakrishnan *et al.*, 2012). In South Africa however, while not a legal requirement, the King III report outlines integrated reporting requirements for organisations (Solomon & Maroun, 2012). The value of BI&A in this context is that it can provide a platform for more accurate and efficient reporting easing the effort required for organisations to meet regulatory reporting requirements (Orton, 2014; Ramakrishnan *et al.*, 2012; Solomon & Maroun, 2012). Therefore, the researcher hypothesises the following:

*H6: Higher regulatory compliance pressure will positively influence BI&A usage extent.*

**Research model**

Building on the TOE framework, the conceptual model, Figure 1 and research hypotheses, Table 1 shows the factors considered for this research study within the technological, organisational and environmental contexts of the TOE framework.

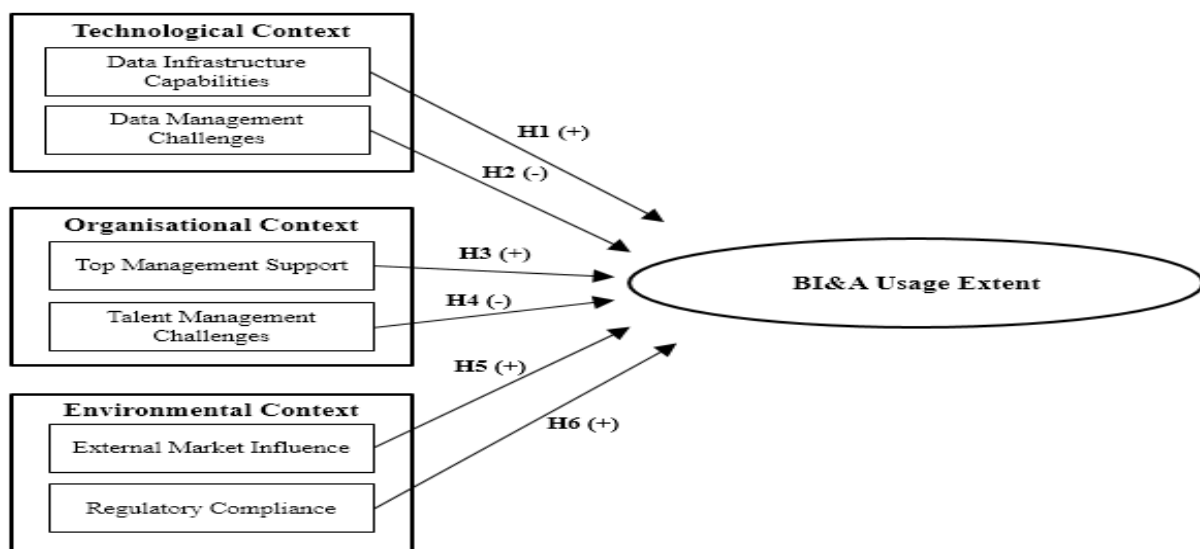

**Figure 1: Conceptual model**

**Table 1: Research hypotheses**

TOE Context	Hypothesis Number	Hypotheses	References
Technological	H1	<i>Data-related infrastructure capabilities will positively influence BI&amp;A usage extent.</i>	(Huang <i>et al.</i> , 2012; Lahrmann <i>et al.</i> , 2011; Malladi & Krishnan, 2013; Zhu <i>et al.</i> , 2006)
	H2	<i>Data quality and data management challenges will negatively influence BI&amp;A usage extent.</i>	(Mungree <i>et al.</i> , 2013; Ramamurthy <i>et al.</i> , 2008; Yeoh & Koronios, 2010)
Organisational	H3	<i>Increased top management support will positively influence BI&amp;A usage extent.</i>	(Bijker & Hart, 2013; Dawson & van Belle, 2013; LaValle <i>et al.</i> , 2011; Mungree <i>et al.</i> , 2013; Watson & Wixom, 2007)
	H4	<i>Talent management challenges will negatively influence BI&amp;A usage extent.</i>	(Davenport & Patil, D. J., 2012; McAfee & Brynjolfsson, 2012; Yeoh & Koronios, 2010)
Environmental	H5	<i>External market factors and competitive intensity positively influence BI&amp;A usage extent.</i>	(Davenport, 2006; Malladi & Krishnan, 2013)
	H6	<i>Higher regulatory compliance pressure will positively influence BI&amp;A usage extent.</i>	(Orton, 2014; Ramakrishnan <i>et al.</i> , 2012; Solomon & Maroun, 2012)

### Research methodology and data analysis

The aim of the research was to independently and objectively observe from an external viewpoint what factors influence BI&A usage extent within South African organisations. A positivist philosophy is associated with scientifically based principles of observation and allows for examination of these factors (Saunders, Lewis & Thornhill, 2009). The researcher used an existing technology adoption framework to structure and formulate the research. Hence, the research approach was deductive as the study tested the collected data against a theoretical framework (Saunders *et al.* 2009).

A quantitative approach was used, as it is appropriate for testing the hypotheses outlined in this research design. A quantitative study on BI&A usage within an organisational context was used previously by Malladi and Krishnan (2013). While this study was quantitative, the survey questionnaire included two open-ended questions allowing participants to add clarity to their responses thereby adding rigour to the study and allowing for richer insight, understanding and interpretation into factors that may influence BI&A usage extent.

Sample candidates were selected from organisations that were already using some form of BI&A in the major South African metropolitan areas. Within these organisations, people responsible for BI&A solutions or otherwise involved in BI&A implementations and support were targeted. These included CIO's, IT and BI managers, executive decision makers, business analysts and systems architects. The profile of these respondents was deemed most suited to answer questions relating to BI&A usage extent, as these respondents were most likely to have knowledge of their organisations BI&A usage and implementations. Potential candidates were contacted via email and invited to participate in the study voluntarily, and the final valid sample size was 72.

Of the 72 valid responses 45 were classified as managers, 14 as executives and 13 as expert/specialists. There were a high number of IT managers (26), BI managers (10) and executive level employees (14) in the sample, together making up 69%

of the total respondents. Only 8 of the respondents came from organisations smaller than 200 employees, the remainder being from large or very large organisations. The industry sectors of the respondents show that a large proportion (44%) came from either the manufacturing or financial and insurance activities sectors.

The respondents were asked to select the business activities in their organisations for which BI&A was being used. The most selected activities were financial analysis (58), business activity monitoring (44), forecasting (43) and sales tracking (41) with much fewer organisations using BI&A for corporate governance (15), product marketing (12) and fraud prevention activities (10). Some of the additional business activities mentioned by respondents were logistics/merchandise planning, customer value management, human resources and credit management.

### Findings

Based on the results of the correlation analysis and multiple regression analysis, the results of the hypotheses testing are outlined and summarised in Table 2. A detailed discussion of these results follows.

#### Data-related infrastructure capabilities

The results of the multiple regression analysis show that H1 is supported. Since the p-value (0.00531) was less than 0.05, there is enough evidence to reject the null hypothesis and therefore infer that data-related infrastructure capabilities do have a positive effect on BI&A usage extent. Data-related infrastructure capabilities such as data warehouses and tools that are used for integrating, cleaning and transforming data for consumption by BI&A are viewed as fundamental in enabling BI&A usage (Watson & Wixom, 2007). They provide a platform for BI&A use, serving as strong foundational layers on which BI&A initiatives can be built and which BI&A can leverage. Without these capabilities, organisations would not have the capacity to utilise BI&A effectively. Certainly, organisations with more data-related infrastructure capabilities exhibit greater BI&A usage extent.

Azvine, Cui, and Nauck (2005) emphasise the importance of having a supportive data integration layer to enable effective BI&A use and stress the importance of feeding data from various operational systems into a data warehouse. This can only be achieved if the necessary data-related infrastructure capabilities are present.

Furthermore, organisations show more capabilities with handling and processing of structured data rather than unstructured data with 76% of respondents indicating that they have on-premises data warehouses and only four respondents indicating that they were using Hadoop or other non-relational (NoSQL) platforms. It can be inferred from this, that few organisations are undertaking big data initiatives.

### Data management challenges

The p-value on the regression analysis for H2 of 0.35218 and greater than 0.05 means that there is not enough evidence to reject the null hypothesis. H2 is therefore not supported, and data management challenges have no significant effect on BI&A usage extent. This result contradicts the findings of Malladi and Krishnan (2013) who found data management challenges to be both significant and negatively correlated with BI&A usage extent.

An interesting finding of data management challenges is that it was found to be strongly and positively correlated with BI&A usage extent. This was indicated by the Spearman's rank correlation coefficient of 0.275 significant at  $p < 0.05$  level. In contrast to this finding, the researcher hypothesised a negative correlation as it was thought that challenges relating to data management would in fact impede or

negatively influence BI&A usage extent. The actual correlation, however, was shown to be positive. Furthermore, correlation does not imply causality but rather an association. The positive yet significant correlation between data management challenges and BI&A usage extent simply indicates that the more organisations use BI&A, the more challenges relating to data management are encountered.

In addition, an interesting observation from the analysis of the open-ended questions, was that respondents frequently indicated data management factors as either aiding or hindering BI&A usage extent with one respondent saying: "In some cases data quality at the source systems is not a problem (aid); in other circumstances it's a big problem (hinder)".

The data management factor was also the most frequently mentioned factor for both aiding and hindering extensive BI&A use being mentioned by 17 and 18 respondents respectively. One respondent indicated that it aids BI&A usage extent by saying: "Quality or sound information for the users to trust the system. Having one version of the truth". Another respondent was saying, "A large amount of manual data preparation due to data quality issues" hinders BI&A usage.

It can be surmised therefore that organisations frequently grapple with data management challenges and in particular view the quality of available data as important to their BI&A undertakings. This finding is consistent with other research into critical success factors relating to the BI&A domain by Wixom and Watson (2001), Wieder and Ossimitz (2013), Olbrich, Poppelbuß and Niehaves (2012), and Dawson and van Belle (2013) who also noted the importance and impact of data quality for BI&A.

**Table 1: Results of hypotheses testing**

Hypothesis	Independent Variable	Dependent Variable	Beta Value $\beta$	p-level ( $p < 0.05$ )	Indicator
H1	Data-related Infrastructure Capabilities (DIC)	BI&A Usage Extent (BIAUE)	.350	<b>.005311</b>	<b>Supported</b>
H2	Data Management Challenges (DMC)	BI&A Usage Extent (BIAUE)	.038	.352183	Not supported
H3	Top Management Support (TMS)	BI&A Usage Extent (BIAUE)	.799	<b>.001416</b>	<b>Supported</b>
H4	Talent Management Challenges (TMC)	BI&A Usage Extent (BIAUE)	.241	.443733	Not supported
H5	External Market Influence (EMI)	BI&A Usage Extent (BIAUE)	.223	<b>.030829</b>	<b>Supported</b>
H6	Regulatory Compliance (RC)	BI&A Usage Extent (BIAUE)	.278	.196057	Not supported

### Top management support

Top management support has the strongest influence on BI&A usage extent in the regression analysis. As H3 has a p-value of 0.001416, which is less than 0.05, the hypotheses are supported, and it is therefore inferred that top management support does have a positive influence on BI&A usage extent.

Consistent with this finding, and present throughout the literature on BI&A usage is mention of top management's support of BI&A and its influence on BI&A usage and subsequent success. Top management support, was found to be ranked highly as a critical success factor for BI&A in prior studies by Bijker and Hart (2013), Watson and Wixom

(2007), and Dawson and van Belle (2013). Top management can assist in providing the necessary resources, whether financial or human, that are needed to overcome organisational issues around BI&A implementations and are able also to provide the needed prioritisation, support and backing of BI&A use within organisations (Mungree *et al.*, 2013).

However, top management needs to be aware of the value that BI&A offers or else their support may be lacking. When top management are informed about the value and benefits offered by BI&A, they are more likely to be supportive of its use. As one respondent stated:



"A key element is senior management and executives understanding the potential benefit that a BI platform can deliver to the business. BI aims at providing key strategic and tactical resources the information at their fingertips required to manage an organisation effectively. Without this insight, executive sponsorship will be lacking, and the implementation of a BI platform will be relegated on a priority list."

Additionally, inferred in this finding, is that absence of support from top management hinders and can be an obstacle to BI&A usage extent. Top management was mentioned seven times as a hindrance, with one respondent saying: "Lack of Senior Management, Executives to fully understand the value of BI&A and to buy in with developing and utilisation thereof."

### Talent management challenges

The regression analysis for H4 gave a p-value of 0.443733 (i.e. greater than 0.05). It can thus be concluded that the null hypothesis for H4 should not be rejected and that talent management challenges have no effect on BI&A usage extent.

While the talent management factor was not found to have a statistical influence on BI&A usage extent, some interesting observations about the data, as well as the responses to the open-ended questions, can nonetheless be made. Respondents were asked to select which of the following four challenges relating to talent management they felt hindered BI&A usage extent: BI/analytics talent is too expensive to hire; Training internal staff is too time-intensive and costly; Finding skilled BI/analytics resources is a challenge; Other (please specify).

Of the 72 respondents, 72% indicated that finding skilled BI/analytics resources is a challenge, while 47% of the respondent also indicated that BI/analytics talent is too expensive to hire, with one respondent citing "not prepared to pay for it" as a reason and another "headcount constraints" as a reason. In addition to this, skills and resources were listed most frequently as a hindrance to BI&A usage extent in the open-ended questions being mentioned 18 times, and it also featured as an aid being mentioned six times.

An analysis of this information would suggest that while issues relating to talent management do not statistically influence BI&A usage extent, organisations still face these issues. The findings infer that there may be a shortage of skilled BI&A resources available in the South African market with 72% of respondents indicating that finding skilled BI&A resources is a challenge. Not only are resources scarce, but half of the respondents (47%) feel that they cannot afford them and that they are too expensive to hire. Respondents also indicated that if the correct skills were not available, then BI&A usage would be constrained. One respondent was indicating, "The challenge with the availability of skilled resources to implement such projects".

### External market influence

The effect of external market influence on BI&A usage extent is positive, and the hypothesis H5 is supported with the regression analysis giving a p-value of 0.030829. External market influence, therefore, does have a positive and significant influence on BI&A usage extent as the p-value is less than 0.05.

An analysis of the data showed that organisations mostly strongly agreed that their industry was highly competitive. As asserted by Masrek *et al.* (2009), organisations who operate in competitive environments are more likely to adopt and utilise information systems (IS) strategically, and while this is not specific to the BI&A domain, Davenport (2006) cites numerous examples of organisations utilising BI&A strategically to edge ahead of competitors. Central to using BI&A strategically, is the recognition by organisations that there is great value in their data assets and BI&A is the conduit through which organisations can realise this value (Davenport, 2006). The environment in which organisations operate exerts pressures on them to remain competitive, and it can be inferred that organisations may view BI&A as a competitive differentiator.

Moreover, the view that BI&A can be used to achieve competitive advantage is on the rise indicating that more organisations are recognising the benefits that BI&A can offer (Kiron & Shockley, 2011).

Furthermore, organisations indicated that industry competitive pressures might be a strong driver of BI&A usage extent. A similar conclusion might be inferred since most organisations agree that they view BI&A as key to gaining a competitive advantage over rivals.

However, the competitive intensity was mentioned by only three respondents as an aid to extensive BI&A usage extent.

### Regulatory compliance

The regression analysis of H6 gave a p-value of 0.196057 and therefore the null hypothesis is accepted, and H6 is not supported. It can be inferred that regulatory compliance does not influence BI&A usage extent.

It is recognised that South Africa is a leader in promoting corporate governance reform because of its historical context of political, social and environmental challenges (Solomon & Maroun, 2012). The Johannesburg Stock Exchange (JSE) in 2010 became the first stock exchange to enforce integrating reporting requirements (reporting on both sustainability and financial information in one report) via compliance to the King III reporting code on listed companies. However, integrated reporting is not a legal requirement. Nevertheless, some of the aspects of the King code of conduct form part of the Companies Act of 2008 (Solomon & Maroun, 2012). The pressure to comply with regulatory requirements was thought therefore to have a positive influence on BI&A usage extent by using BI&A to satisfy these reporting requirements.

However, this was not confirmed through the regression analysis of the data in this study.

It could be posited that while organisations might be pressured by regulatory compliance requirements, that these pressures are not necessarily being addressed through using BI&A per se. It might be that these reporting requirements fall outside of the BI&A domain and rather form part of the financial and auditing practices of organisations. This study, however, does not address this conjecture. Also, regulatory reporting requirements address a specific reporting need, and BI&A usage is much broader in scope covering other subject areas and business activities. None of the respondents mentioned regulatory requirements as a factor either aiding or hindering BI&A usage extent.

## Conclusion

This study examined within a South African context, how certain factors influence actual BI&A usage extent. Factors that were proven influential from prior studies within each of the T, O and E contexts of the TOE framework were considered.

The practice of data-driven decision making supported by effective BI&A usage, in contrast to intuition based or gut feel decision making, has proven to be a differentiator between organisations. Previous studies show that organisations who embrace fact-based decision-making show increased productivity as well as profitability (Brynjolfsson *et al.*, 2011; LaValle *et al.*, 2011).

Data-related infrastructure capabilities were found to be significantly influential on BI&A usage extent. A key enabler and considered a foundational layer for effective BI&A use, organisations with strong data-related infrastructures are better positioned to leverage BI&A benefits. Organisations wishing to further BI&A usage might consider evaluating their current data-related infrastructure capabilities and investigate if these are worth improving, strengthening or expanding.

A necessary ingredient for extensive BI&A use is top management support. Top management can help drive BI&A use within their organisations through the following measures: providing needed resources be they monetary or human; actively promoting, endorsing and fostering its use; and managing change and removing organisational barriers related to its usage. Organisations are advised that BI&A usage is best driven from the top down. It is also imperative that top management educates and inform themselves as to the value and benefits that can be derived through BI&A use. As Clark, Jones and Armstrong (2007: 589) assert, "A manager's commitment to the system is influenced most directly by his or her perceptions of benefits that accrue from its use."

External market influence drives greater BI&A usage by exerting pressure on organisations to gain competitive advantages. Organisations view the effective utilisation of BI&A as a strategic endeavour that can drive organisational

performance, and can be used to exploit their rich data assets to outperform industry competitors. Strategic use of BI&A might, therefore, offer organisations advantages.

While the data management challenges factor was statistically insignificantly influential on BI&A usage extent, data quality is still critical. Organisational efforts to provide good quality data for BI&A consumption should be strongly encouraged. Challenges relating to managing talent were also not significantly influential on BI&A usage extent. Nevertheless, organisations are advised to train and educate users on BI&A use and benefits, particularly since skilled BI&A resources in South Africa are difficult to find.

This study also found that one factor from each of the T (Data-related Infrastructure Capabilities), O (Top Management Support) and E (External Market Influence) contexts of the TOE framework was significant indicating that this framework is appropriate for gaining insight into BI&A usage at an organisational level. Therefore, only three of the original six hypothesised factors were found to have a significant impact on BI&A usage extent.

The findings presented in this study provide some new perspectives into factors that influence BI&A usage extent for both BI&A practitioners and researchers alike. Organisations wishing to promote fact-based decision making through greater BI&A usage are specifically encouraged to consider Data-related Infrastructure Capabilities, Top Management Support, and External Market Influence, and it is expected that this, in turn, will lead to increased organisational performance.

## References

- Aulkemeier, F., Paramartha, M.A., Iacob, M.E. & van Hillegersberg, J. 2015. 'A pluggable service platform architecture for e-commerce', *Information Systems and e-Business Management*, 1-21.
- Azvine, B., Cui, Z. & Nauck, D.D. 2005. 'Towards real-time business intelligence', *BT Technology Journal*, 23(3): 214-225.
- Bijker, M. & Hart, M.(Eds.) 2013. *Factors Influencing Pervasiveness of Organisational Business Intelligence*. 'BUSTECH 2013, The Third International Conference on Business Intelligence and Technology', 27 May - 1 June, Valencia, Spain.
- Bose, R. 2009. 'Advanced analytics: opportunities and challenges', *Industrial Management & Data Systems*, 109(2):155-172.
- Brynjolfsson, E., Hitt, L.M. & Kim, H.H. 2011. *Strength in Numbers: How Does Data-Driven Decisionmaking Affect Firm Performance?* [online] <http://ssrn.com/abstract=1819486>.
- Cates, J.E., Gill, S.S. & Zeituny, N. 2005. 'The Ladder of Business Intelligence (LOBI): a framework for enterprise IT planning and architecture', *International Journal of Business Information Systems*, 1(1/2): 220-238.
- Chaudhuri, S., Dayal, U. & Narasayya, V. 2011. 'An overview of business intelligence technology', *Communications of the ACM*, 54(8): 88-98.

- Chen, H., Chiang, R.H.L. & Storey, V.C. 2012. 'Business Intelligence and Analytics: From Big Data to Big Impact', *MIS Quarterly*, **36**(4): 1165-1188.
- Clark, T.D., Jones, M.C. & Armstrong, C.P. 2007. 'The dynamic structure of management support systems: theory development, research focus, and direction,' *MIS Quarterly*, **31**(3): 579-615.
- Davenport, T.H. 2006. 'Competing on analytics', *Harvard Business Review*, **84**(1): 99-107.
- Davenport, T.H. 2013a. 'Analytics 3.0', *Harvard Business Review*, **91**(12): 64-72.
- Davenport, T.H. 2013b. 'Keep up with your quants', *Harvard Business Review*, **91**(7/8): 120-123.
- Davenport, T.H. & Dyché, J. 2013. *Big Data in Big Companies*. [online] [http://docs.media.bitpipe.com/io\\_10x/io\\_102267/item\\_725049/Big-Data-in-Big-Companies.pdf](http://docs.media.bitpipe.com/io_10x/io_102267/item_725049/Big-Data-in-Big-Companies.pdf)
- Davenport, T.H. & Patil, D.J. 2012. 'Data scientist: The sexiest job of the 21st century', *Harvard Business Review*, **90**(10): 70-76.
- Dawson, L. & van Belle, J.P. 2013. 'Critical success factors for business intelligence in the South African financial services sector', *South African Journal of Information Management*, **15**(1): 1-12.
- DeLone, W.H. & McLean, E.R. 2003. 'The DeLone and McLean model of information systems success: A ten-year update,' *Journal of management information systems*, **19**(4): 9-30.
- DeLone, W.H. & McLean, E.R. 1992. 'Information systems success: The quest for the dependent variable', *Information systems research*, **3**(1): 60-95.
- Eckerson, W. 2007. *Beyond the basics: Accelerating BI maturity*. [online] <http://www.sdn.sap.com/irj/scn/go/portal/prtroot/docs/library/uuid/b070feb8-ecd4-2910-e9b9-c495b4d30c67?QuickLink=index&overridelayout=true&12962211329836>.
- Elbashir, M.Z., Collier, P.A. & Sutton, S.G. 2011. 'The role of organizational absorptive capacity in strategic use of business intelligence to support integrated management control systems', *The Accounting Review*, **86**(1): 155-184.
- Hribar Rajterič, I. 2010. 'Overview of business intelligence maturity models', *Management: Journal of Contemporary Management Issues*, **15**(1): 47-67.
- Huang, T.C.K., Liu, C.C. & Chang, D.C. 2012. 'An empirical investigation of factors influencing the adoption of data mining tools', *International Journal of Information Management*, **32**(3): 257-270.
- Kiron, D. & Shockley, R. 2011. 'Creating business value with analytics', *MIT Sloan Management Review*, **53**(1): 56-63.
- Kwon, O., Lee, N. & Shin, B. 2014. 'Data quality management, data usage experience and acquisition intention of big data analytics', *International Journal of Information Management*, **34**(3): 387-394.
- Lahrman, G., Marx, F., Winter, R. & Wortmann, F.(Eds.) 2011. *Business intelligence maturity: Development and evaluation of a theoretical model*. 'System Sciences (HICSS), 2011 44th Hawaii International Conference on Kauai', 4-7 January, HI: IEEE.
- LaValle, S., Lesser, E., Shockley, R., Hopkins, M. S. & Kruschwitz, N. 2011. 'Big data, analytics and the path from insights to value', *MIT Sloan Management Review*, **52**(2): 21-34.
- Low, C., Chen, Y. & Wu, M. 2011. 'Understanding the determinants of cloud computing adoption', *Industrial Management & Data Systems*, **111**(7): 1006-1023.
- Luftman, J., Derksen, B., Dwived, R., Santana, M., Zadeh, H.S. & Rigoni, E. 2015. 'Influential IT Management Trends: An International Study', *Journal of Information Technology*, **30**(3): 293-305.
- Luftman, J., Zadeh, H.S., Derksen, B., Santana, M., Rigoni, E.H. & Huang, Z.D. 2013. 'Key information technology and management issues 2012–2013: an international study', *Journal of Information Technology*, **28**(4): 354-366.
- Malladi, S. & Krishnan, M. 2013. *Determinants of Usage Variations of Business Intelligence & Analytics in Organizations – An Empirical Analysis*. 'Thirty Fourth International Conference on Information Systems', Milan
- Masrek, M.N., Jamaludin, A. & Hashim, D.M. 2009. 'Determinants of strategic utilization of information systems: A conceptual framework', *Journal of Software*, **4**(6): 591-598.
- McAfee, A. & Brynjolfsson, E. 2012. 'Big data: The management revolution', *Harvard Business Review*, **90**(10): 60-68.
- Mungree, D., Rudra, A. & Morien, D.(Eds.) 2013. *A framework for understanding the critical success factors of enterprise business intelligence implementation*. 'Proceedings of the Nineteenth Americas Conference on Information Systems', Chicago, Illinois, 15-17 August.
- Negash, S. 2004. 'Business intelligence', *Communications of the Association for Information Systems*, **13**(13): 177-195.
- Olbrich, S., Poppelbuß, J. & Niehaves, B. 2012. 'Critical Contextual Success Factors for Business Intelligence: A Delphi Study on Their Relevance, Variability, and Controllability', *In 45th Hawaii International Conference on System Sciences (HICSS)* (pp. 4148–4157), Hawaii, USA.
- Oliveira, T. & Martins, M.F. 2011. 'Literature review of information technology adoption models at firm level', *Electronic Journal of Information Systems Evaluation*, **14**(1): 110-121.
- Orton, S. 2014. *Opinion piece: Better BI for greater adherence to King III | Company Press Releases*. [online] <http://companies.mybroadband.co.za/blog/2011/08/29/opinion-piece-better-bi-for-greater-adherence-to-king-iii/>
- Pettey, C. & van der Meulen, R. 2013. *Gartner Executive Program Survey of More Than 2,000 CIOs Shows Digital Technologies Are Top Priorities in 2013*. [online] <http://www.gartner.com/newsroom/id/2304615>.
- Popovič, A., Hackney, R., Coelho, P.S. & Jaklič, J. 2012. 'Towards business intelligence systems success: Effects of maturity and culture on analytical decision making', *Decision Support Systems*, **54**(1): 729-739.
- Ramakrishnan, T., Jones, M.C. & Sidorova, A. 2012. 'Factors influencing business intelligence (BI) data collection strategies: An empirical investigation', *Decision Support Systems*, **52**(2): 486-496.

- Ramamurthy, K.R., Sen, A. & Sinha, A.P. 2008. 'An empirical investigation of the key determinants of data warehouse adoption', *Decision Support Systems*, **44**(4): 817-841.
- Rogers, E.M. 1995. *Diffusion of Innovations*. New York, NY: The Free Press.
- Rouhani, S., Ashrafi, A., Zare, A. & Afshari, S. 2016. 'The impact model of business intelligence on decision support and organizational benefits', *Journal of Enterprise Information Management*, **29**(1): 19-50.
- Saunders, M., Lewis, P. & Thornhill, A. 2009. *Research Methods for Business Students*. 5th Edition. London: Pearson Education/Prentice Hall.
- Seddon, P.B., Constantinidis, D. & Dod, H.(Eds.) 2012. *How Does Business Analytics Contribute to Business Value?* 'Thirty-Third International Conference on Information Systems', 14 December, Orlando, Florida, USA. [online] <http://aisel.aisnet.org/icis2012>.
- Shollo, A. & Galliers, R.D. 2015. 'Towards an understanding of the role of business intelligence systems in organisational knowing', *Information Systems Journal*, **26**(4): 339-367.
- Sidorova, A. & Torres, R. 2015. 'Business Intelligence and Analytics as a Foundation for Organizational Dynamic Capabilities', *Twenty-first Americas Conference on Information Systems*, Puerto Rico.
- Solomon, J. & Maroun, W. 2012. 'Integrated reporting: the influence of King III on social, ethical and environmental reporting (Sustainability reporting publications (ACCA))', London. [online] <http://hdl.handle.net/10023/3749>.
- Tornatzky, L.G. & Fleischer, M. 1990. *The processes of technological innovation*. Lexington, Mass: Lexington Books.
- Watson, H.J. & Wixom, B.H. 2007. 'The current state of business intelligence', *Computer*, **40**(9):96-99.
- Wieder, B. & Ossimitz, M.L.(Eds.) 2013. 'Managing Business Intelligence for Success: Factors and Mechanisms', *Proceedings of the International Conference on Management and Information Systems*, 22-24 September.
- Wixom, B. & Watson, H. 2010. 'The BI-based organization', *International Journal of Business Intelligence Research (IJBIR)*, **1**(1): 13-28.
- Wixom, B.H. & Watson, H.J. 2001. 'An empirical investigation of the factors affecting data warehousing success', *MIS Quarterly*, **25**(1): 17-41.
- Yeoh, W. & Koronios, A. 2010. 'Critical success factors for business intelligence systems', *Journal of Computer Information Systems*, **50**(3): 23-32.
- Yeoh, W. & Popovič, A. 2015. 'Extending the understanding of critical success factors for implementing business intelligence systems', *Journal of the Association for Information Science and Technology*, **67**(1): 134-147.
- Yi, M.Y., Jackson, J.D., Park, J.S. & Probst, J.C. 2006. 'Understanding information technology acceptance by individual professionals: Toward an integrative view', *Information & Management*, **43**(3): 350-363.
- Zhu, K., Kraemer, K.L. & Xu, S. 2006. 'The process of innovation assimilation by firms in different countries: A technology diffusion perspective on e-business', *Management Science*, **52**(10): 1557-1576.
- Zikopoulos, P.C., deRoos, D., Parasuraman, K., Deutsch, T., Giles, J. & Corrigan, D. 2013. *Harness the power of big data the IBM big data platform*. McGraw-Hill Professional.