

Ronzani, Daniel

Doctoral Thesis

When bits learn to walk don't make them trip. Technological innovation and the role of regulation by law in information systems research: The case of Radio Frequency Identification (RFID)

DBA PhD Series, No. 2.2009

Provided in Cooperation with:

Copenhagen Business School (CBS)

Suggested Citation: Ronzani, Daniel (2009) : When bits learn to walk don't make them trip. Technological innovation and the role of regulation by law in information systems research: The case of Radio Frequency Identification (RFID), DBA PhD Series, No. 2.2009, ISBN 9788759384077, Copenhagen Business School (CBS), Frederiksberg, <https://hdl.handle.net/10398/7930>

This Version is available at:

<https://hdl.handle.net/10419/208711>

Standard-Nutzungsbedingungen:

Die Dokumente auf EconStor dürfen zu eigenen wissenschaftlichen Zwecken und zum Privatgebrauch gespeichert und kopiert werden.

Sie dürfen die Dokumente nicht für öffentliche oder kommerzielle Zwecke vervielfältigen, öffentlich ausstellen, öffentlich zugänglich machen, vertreiben oder anderweitig nutzen.

Sofern die Verfasser die Dokumente unter Open-Content-Lizenzen (insbesondere CC-Lizenzen) zur Verfügung gestellt haben sollten, gelten abweichend von diesen Nutzungsbedingungen die in der dort genannten Lizenz gewährten Nutzungsrechte.

Terms of use:

Documents in EconStor may be saved and copied for your personal and scholarly purposes.

You are not to copy documents for public or commercial purposes, to exhibit the documents publicly, to make them publicly available on the internet, or to distribute or otherwise use the documents in public.

If the documents have been made available under an Open Content Licence (especially Creative Commons Licences), you may exercise further usage rights as specified in the indicated licence.



<https://creativecommons.org/licenses/by-nc-nd/3.0/>

COPENHAGEN BUSINESS SCHOOL
HANDELSHØJSKOLEN
SOLBJERG PLADS 3
DK-2000 FREDERIKSBERG
DANMARK

www.cbs.dk



**Copenhagen
Business School**
HANDELSHØJSKOLEN

When Bits Learn to Walk
Don't Make Them Trip

When Bits Learn to Walk Don't Make Them Trip

Technological Innovation and the Role of Regulation
by Law in Information Systems Research: the Case of
Radio Frequency Identification (RFID)

Daniel Ronzani

ISBN 978-87-593-8407-7

ISBN 978-87-593-8407-7



Doctoral Dissertation

Programme in Informatics

Doctoral Dissertation

When Bits Learn to Walk Don't Make Them Trip

Daniel Ronzani

When Bits Learn to Walk Don't Make Them Trip

*Technological Innovation and the Role of Regulation by Law in Information Systems Research:
the Case of Radio Frequency Identification (RFID)*

1st edition 2009

© The Author

ISBN: 978-87-593-8407-7

LIMAC PhD School is a cross disciplinary PhD School connected to research communities within the areas of Languages, Law, Informatics, Operations Management, Accounting, Communication and Cultural Studies.

All rights reserved.

No parts of this book may be reproduced or transmitted in any form or by any means, electronic or mechanical, including photocopying, recording, or by any information storage or retrieval system, without permission in writing from the publisher.

When Bits Learn To Walk Don't Make Them Trip

Technological Innovation and the Role of
Regulation by Law in Information Systems Research:
the Case of Radio Frequency Identification (RFID)

LIMAC PhD School; Programme in Informatics
Copenhagen Business School
Center for Applied Information and Communication Technology

Daniel Ronzani

Abstract (English)

This paper-based thesis attempts to answer the question how the adoption and diffusion of RFID can be balanced successfully between technological innovation and regulation by law. To answer this question, an abductive reasoning perspective has been applied. The first premise of abduction includes four sets of observations presented in four articles; the second premise of abduction includes two hypothetical claims, and the third premise of abduction builds the case, i.e., concludes the thesis.

As first step, the definitional framework is established. Ten theories of adoption and diffusion of technological innovation (TRA, TPB, MPCU, SCT, TAM, TAM2, C-TAM-TPB, IDT, PCI, and UTAUT) and their characteristics are investigated. They frame the technological viewpoint. Then, the reasons for regulation (public interest theory, private interest theory, and institutionalist theory) as well as the means of regulation (regulation by law, norms, market, and architecture) and their application are investigated. They frame the regulatory viewpoint.

As second step, four observations are made that constitute the first premise of abduction based on the findings of four individual research articles referred to as the Database Article, Marketing Article, Modality Mix Article, and Survey Article:

Database Article: This research article evaluates the strategic advantage of placing RFID databases in certain territorial and jurisdictional regions based on database regulation. The analysis of the database regulation by law in Europe and North America revealed that, based on the creativity, skill and judgement, and investment doctrine, they do not protect RFID data in databases. It is claimed that protection of RFID data in databases should be regulated by other means of regulation, for instance, by regulation by norms or architecture. Observation 1 stipulates: Despite the amount of data anticipated to be stored and the regulation by law in the different countries where RFID is adopted and diffused, the location of the databases containing RFID data does not seem to play an important role for the technological innovator.

Marketing Article: This research article applies a legal use case for the technological innovations marketed by the industry as active RFID tags. The analysis of the RFID industry's marketing efforts and the

legal community's interpretation of RFID technology shows that unfavourable regulation by law is possible, and likely. Adopting the broad legal interpretation of self-emitting devices (short-range devices) to RFID tags that need to transduce energy from an RFID reader (active RFID tags) might allow the search and seizure of transmitted RFID data without a warrant to be in line with the constitutional rights. It is claimed that within the RFID industry there should be more awareness of regulation by legislation and adjudication. Observation 2 stipulates: Extending the doctrinal definition of active RFID tags to include reader-independent and indiscriminate signalling might lead to unfavourable regulation by law.

Modality Mix Article: This research article offers a reflection on how law must manage the evolution of technological innovation. The analysis of the Draft Recommendation (2008) by the European Commission shows that the focus on regulation by law is inappropriate for a manageable diffusion of RFID technology. An over-regulation of RFID technology by regulation by law is possible if the Draft Recommendation (2008) is implemented and comes into force. It is claimed that a more diverse set of modalities (regulation by norms, market, and architecture) is necessary to successfully regulate RFID technology. Observation 3 stipulates: The current adoption and diffusion of RFID technology do not seem to be following an appropriate mix of regulation.

Survey Article: This research article provides a reverse perspective of current RFID issues by examining the RFID industry's view of regulation by law and consumers. The analysis of the survey data of the RFID industry shows three shortcomings by the RFID industry in its engagement of legal experts, its knowledge of regulation by law for RFID subject-matter, and its information policy to the general public. It is claimed that the exchange between the RFID industry and the legal regulator needs to improve. Observation 4 stipulates: The interaction between, and consequently also the exchange of expert know-how and standpoints of, (i) the RFID industry and the legal regulator and (ii) the RFID industry and the consumers seem insufficient.

As third step, two hypothetical claims are made as second premise of abduction based on a literature review of characteristics of adoption and diffusion of technological innovation in IS research, namely IT, EDI, and RFID. *First*, the research shows that in IS research there are

only a few regulation-by-law characteristics (5 of 150 different characteristics). Thus, a first hypothetical claim is made that in IS research there is a lack of legal perspectives. *Second*, the research shows that in IS research there are even fewer characteristics of other regulatory means, such as for example, social norms, market or architecture. Thus a second hypothetical claim is made that in IS research there is a lack of diversity in regulation of technological innovation.

Finally, a case is built as third premise of abduction. It seems possible to conclude that (i) based on observation 1 and hypothetical claim 2, increasing the diversity of regulation modalities might have a positive effect on the strategic management decisions for the location of RFID systems; (ii) based on observation 2 and hypothetical claim 1, increasing the legal perspective in IS research might have a positive effect on the RFID industry's marketing strategy; (iii) based on observation 3 and hypothetical claim 2, a more thorough and precise review of essential regulation by law is necessary; and (iv) based on observation 4 and hypothetical claim 1, increasing the legal perspective in IS research might have a positive effect on the RFID industry's awareness of the legal challenges and their consequences.

It is suggested that the four cases (conclusions) built in this thesis provide a solid foundation for the following four hypotheses that can be further tested with additional empirical data:

1. Increasing the diversity of regulation modalities has a positive effect on the strategic management decisions for the deployment location of technological innovation.
2. Increasing the legal perspective in IS research has a positive effect on the marketing strategy for technological innovation.
3. Increasing the thoroughness and precision in the review of essential regulation by law has a positive effect on other regulatory tools for technological innovation.
4. Increasing the legal perspective in IS research has a positive effect on the industry's awareness of the legal challenges and their consequences.

Therefore, to prevent bits from falling once they have learned to walk, the legal perspective of regulation in IS research as well as the diverse implementation of regulation in IS research should probably

be increased. Such an increase might augment the awareness for the potential of regulation in technological innovation, which, in turn, might foster the adoption and diffusion of RFID.

Keywords: RFID, technological innovation, IS, regulation, law, abduction.

Abstrakt (Dansk)

Denne paperbaserede afhandling forsøger at besvare spørgsmålet om, hvordan indførelsen og udbredelsen af RFID kan balancere mellem teknologisk innovation og regulering ved lov. For at besvare dette spørgsmål er der blevet anvendt et abduktivt perspektiv. Den første forudsætning for abduktion præsenteres i fire artikler; den anden forudsætning for abduktion omfatter to hypotetiske påstande, og den tredje forudsætning for abduktion afslutter, dvs konkluderer afhandlingen.

Som det første skridt etableres et framework. Ti teorier for adoption og udbredelse af teknologisk innovation beskrives (TRA, TPB, MPCU, SCT, TAM, TAM2, C-TAM-TPB, IDT, PCI, og UTAUT) og deres egenskaber er undersøgt. De udgør rammen for det teknologiske perspektiv. Derefter undersøges baggrundene for regulering (teorien om offentlig interesse, teorien om private interesser, og institutionel teori) samt de forskellige typer af regulering (forordning ved lov, normer, marked og arkitektur) og deres respektive anvendelse belyses. Dette udgør rammen for hvad vi kalder forskrifts perspektivet (regulatory perspective).

Som det andet skridt, er der foretaget fire sæt af observationer. Disse udgør den første forudsætning for abduktion baseret på resultaterne i fire individuelle artikler kaldet Database artikel, Marketing artikel, Modalitet Mix artikel, og Survey artikel:

Database artikel: Denne forskningsartikel evaluerer den strategisk fordel i at placere RFID databaser i visse territoriale og juridiske regioner ud fra reglerne om regulering af databasen. Analysen af den legale regulering af databaser i Europa og Nordamerika viste, at RFID data i databaser ikke kan beskyttes på grundlag af kreativitet, dygtighed og dømmekraft, samt investerings doktriner. Det konkluderes derfor, at beskyttelse af RFID-data i databaser bør reguleres ved andre former for regulering, for eksempel ved regulering af normer eller arkitektur. Observation 1 udsiger: Uafhængigt af datamængden, der forventes at blive gemt og den lovgivningsmæssige regulering i de forskellige lande, hvor RFID er vedtaget og udbredt, så synes placeringen af de databaser, der indeholder RFID data ikke at spille en vigtig rolle for den teknologiske innovatør.

Marketing artikel: Denne forskningsartikel anvender et legalt use case på den teknologiske innovationer, der markedsføres af industrien som aktive RFID-tags. Analysen af RFID-industriens markedsføring indsats og de juridiske samfunds fortolkning af RFID-teknologi viser, at uhensigtsmæssig lovmæssig regulering er mulig og sandsynlig. Hvis man anlægger en bred juridiske vurdering af kortdistanceudstyr (short-range devices, og inkluderer RFID-tags, der er nødt til at anvende energi fra en RFID-læser (aktive RFID-tags), så kan søgning og beslaglæggelse af transmitterede RFID-data uden dommerkendelse vise sig at være i overensstemmelse med de forfatningsmæssige rettigheder. Det foreslås derfor, at der inden for RFID-industrien bør være en højere grad af bevidsthed og regulering i medfør af lovgivning og adjudikation. Observation 2 udsiger: Udvidelse af den doktrinære definition af aktive RFID-tags til at omfatte læser-uafhængig og vilkårlige signalering vil kunne føre til en uhensigtsmæssig lovgivning.

Modalitet Mix artikel: Denne forskning artikel redegør for en række overvejelser om, hvorledes lovgivning skal styre udviklingen af den teknologiske innovation. Analysen af udkastet til henstilling (2008) af Europa-Kommissionen viser, at fokusering på lov regulering er uhensigtsmæssig for en styret udbredelsen af RFID-teknologi. En overdreven regulering af RFID-teknologi ved lov forordninger er mulig, hvis udkastet til henstilling (2008) bliver gennemført og træder i kraft. Det hævdes således, at et mere forskelligartet sæt af retningslinjer (regulering af normer, markedet, og arkitektur) er nødvendige for en vellykket regulering af RFID-teknologi. Observation 3 udsiger: Den nuværende vedtagelse og udbredelse af RFID-teknologi synes ikke at ske ud fra en passende blanding af reguleringer.

Survey artikel: Denne forsknings artikel anlægger det modsatte perspektiv på RFID spørgsmålet ved at undersøge RFID industriens opfattelse af lov regulering og forbrugernes opfattelse. Analysen af survey data fra RFID-industrien viser tre af RFID-industrien mangler: dens engagement af juridiske eksperter, dens viden om regulering ved lov for RFID-genstande, og dens informationspolitik over for offentligheden. Det hævdes, at kommunikationen mellem de RFID-industrien og juridisk regulatorer må forbedres. Observation 4 udsiger: Samspillet og dermed også udvekslingen af sagkyndig viden og holdninger mellem, (i) RFID-industrien og juridisk regulatorer samt (ii) RFID-industrien og forbrugere synes utilstrækkelige.

Som det tredje trin, opstilles to hypotetiske udsagn, der udgør den anden forudsætning for abduktion baseret på en litteratur gennemgang af de vigtigste karakteristika for accept og udbredelse af teknologisk innovation inden for IS forskning, dvs IT, EDI, og RFID. For det første viser forskningen, at der inden for IS forskning kun er ganske få regulering-efter-lovgivning karakteristika (5 af 150 forskellige karakteristika). Derfor fremsættes den første hypotese, at der er mangel på juridiske perspektiver inden for IS forskning. For det andet viser forskningen, at der inden for IS forskning er endnu færre eksempler på andre reguleringsmiddel, som for eksempel sociale normer, markeder eller arkitektur. Den anden hypotese er således, at der inden for IS forskning er et udbredt fravær af mangfoldighed i reguleringstiltag, når det drejer sig om teknologisk innovation.

Endelig argumenteres der for den tredje forudsætning for abduktion. Det synes muligt at konkludere (i) baseret på observation 1 og den hypotetiske påstand 2, at en forøgelse af mangfoldigheden i form af flere modaliteter må formodes at have en positiv virkning på de strategiske ledelsesbeslutninger vedrørende geografisk placering af RFID-systemer, (ii) baseret på observation 2 og hypotetiske påstand 1, at et øget juridisk perspektiv i IS forskning vil have en positiv indvirkning på RFID-industriens markedsføringsstrategi, (iii) baseret på observation 3 og hypotetiske påstand 2, at en mere grundig og præcis gennemgang af væsentlige lov regulering er nødvendig, og (iv) baseret på observation 4 og hypotetiske påstand 1, at en forøget vægt på det juridiske perspektiv i IS forskning kan have en positiv indvirkning på RFID-industriens bevidsthed om de juridiske udfordringer og deres konsekvenser.

Det foreslås, at de fire cases (konklusioner), der er opbygget i denne afhandling, vil give et solidt grundlag for de følgende fire hypoteser, som kan yderligere testes med supplerende empiriske data:

1. En forøgelse af mangfoldigheden i regulerings modaliteter har en positiv indvirkning på den strategiske ledelses beslutninger omkring implementering og udbredelse af teknologiske innovation.
2. En forøget anvendelse af det juridiske perspektiv i IS forskning vil have en positiv indvirkning på markedsføringsstrategien for teknologisk innovation.

3. En forøgelse af omhyggeligheden og præcisionen i forbindelse med analyse af nødvendig lovmæssige reguleringer har en positiv virkning på andre lovgivningsmæssige værktøjer til teknologisk innovation.
4. En forøgelse af anvendelsen af det juridiske perspektiv i IS forskning har en positiv indvirkning på industriens bevidsthed om de juridiske udfordringer og deres konsekvenser.

Det kan derfor konkluderes, at "for at forhindre bits i at falde, når de har lært at gå", så bør det juridiske regulerings perspektiv have en langt større plads i IS forskning, lige som anvendelsen af forskellige andre reguleringstiltag i IS forskning formentlig bør øges. En sådan forøgelse kan øge bevidstheden om potentialet for så vidt angår regulering af teknologisk innovation, hvilket igen kan fremme indførelsen og udbredelsen af RFID.

Nøgleord: RFID, teknologisk innovation, informationssystemer, regulering, jura, abduktion.

Acknowledgments

Researching and writing this doctoral thesis were supported and encouraged by many people in many different ways:

The supervision of my research by Professor Niels Bjørn-Andersen over the past few years was certainly an educational experience for me. I am sincerely grateful to Niels for accepting me, an industry lawyer by training and profession, as his part-time student at the PhD School of Informatics and at the Center for Applied Information and Communication Technology (CAICT). Niels left me the utmost liberty in my research interest and thoughts. His openness and flexibility made it possible for me to conduct and manage this research from my hometown in Switzerland. Niels and I spent many hours on the phone discussing my manuscripts and correcting my conference presentations and journal articles. I also thank Niels for his guidance wherever my position might not have been as objective as it could and should have been.

Niels always freed up time for me during my journeys to Copenhagen. There was always time to deliberate and have good conversations at lunch or dinner in the city. I thank Niels for his friendship and hospitality at CAICT as well as for inviting me to his lovely home. Tak!

At CBS I would like to acknowledge: Professors Kim Normann Andersen (CAICT and Head of the PhD School of Informatics), Helle Zinner Henriksen (CAICT), Jonas Hedman (CAICT), Jan Trzaskowski (Law), Lars Håkanson (DBA), and Steen Thomsen (DBA) for their interest in, and input on, early versions of my research and presentations. I also thank Irene Rosberg for managing the DBA programme and Anni Olesen for the administrative support at the PhD School of Informatics.

Appreciation also goes to Professor Rudy Hirschheim from the Louisiana State University, USA, for his comments on an early version of a term paper reflecting my initial philosophical and sociological thoughts on RFID.

There are many people to whom I express particular gratitude at IBM: Dr. Erich Rüttsche, my manager at IBM Research GmbH in Zurich, for the extended flexibility on my short notice absences to attend doctoral seminars and conferences, the instant networking support, the

reviews of, and input for, my work as well as for IBM's generous financial contribution. I also thank at IBM Research GmbH: Dr. Alessandro Curioni, Dr. Eric Cope, Maria Soimu, Nicola Gustafsson, Christina Preisig, Andy Krysl, and especially Charlotte Bolliger for her proof-reading. My gratitude extends to Sebastian Taylor, from IBM Norway, for his networking support and personal input.

I thank my interview partners and all respondents of my survey, whose names I committed to keep confidential, for taking the time to share their professional and personal views with me.

I am grateful to my family, especially my parents Mario and Ketty, for the encouragement to pursue my personal goals; for believing in my abilities to write this thesis; for the continued interest in my research; and their generous financial contribution. I hope my postcards will decorate their refrigerator for a long time.

Finally and foremost, I apologise to my spouse, Caroline. Writing this thesis in parallel to my regular job as industry lawyer was certainly an imposition: During the past three and a half years I egoistically spent most of my holidays, weekday evenings and weekends working on this "thing". I am indebted to you, Caroline, for accepting my tireless work; for reminding me that there is more in life than business and research; for repeatedly listening to and answering the same questions, arguments, and complaints; for your creative input on my thesis; for reading and re-reading hundreds of manuscript pages; for your patience, sacrifice, and expectation; and for being there unconditionally all the time. I know that I used up (too) many brownie points.

In the past years I attended several doctoral seminars and conferences throughout Europe. Caroline joined me for extended weekend trips. We photographed Edvard Eriksen's sculpture of The Little Mermaid in Copenhagen and visited the lovely town of Lund in Sweden; we walked the Gellért Hegy in Buda and Közgazdaságtudományi Egyetem in Pest; we strolled through St. Stephen's Green in Dublin, and crossed the Charles Bridge in Prague. These weekend trips hardly compensate for my too long absences while researching and writing at the library, and for being physically at home but intellectually lost in the ephemeral spheres of

pervasive computing. Nevertheless, I truly hope our journeys will remain in lovely memory.

Zurich and Copenhagen
June 30th, 2009

To Caroline

Foreword

This PhD thesis is submitted in the Doctor of Business Administration (DBA) Programme at the Informatics PhD-School (IPS) of the Copenhagen Business School according to the Executive Order of the Danish Ministry of Education, No. 114 of 8 March 2002 concerning PhD Programmes and PhD Degrees, as well as the Degree Regulations for the PhD Programme in Business Economics (2006).

According to section 8 of the Degree Regulations of the PhD Programme in Business Economics (2006) and the DBA Programme referenced therein, the objective of the DBA study is to educate the candidate who is attached to the labour market and has considerable practical business experience to the level of PhD. The contribution of the PhD thesis is, *inter alia*, to contribute in general to the transfer of knowledge between universities, the business community, and the outside world. To meet the objectives of the DBA Programme, the research of this thesis has been presented at conferences that bring together researchers and practitioners from both academia and industry to facilitate the sharing of applications, research results, and knowledge. It joins business practice, research, and academic understanding of business problems.

In agreement with the Executive Supervisor, the Head of the Informatics PhD School (IPS), and the Dean of the DBA Programme, this research project is submitted as paper-based thesis (section 18(2) of the Degree Regulations for the PhD Programme in Business Economics (2006)). Different topics within the realm of RFID have been researched. The results have been discussed in four law and technology articles and one conference paper. In addition, three of these research projects have been presented at international conferences: In December 2006, the discussion on the absence of legal database protection in the EPCglobal network was presented in Copenhagen, Denmark, at the International Conference on Business, Law and Technology. The second conference attendance was as scientific staff at the International Conference on the Internet of Things (IOT) in Zurich, Switzerland, in March 2008. Marketing issues of active RFID tags were presented at that venue. The final conference presentation on the modality mix of RFID regulation was in Prague, Czech Republic, in September 2008 at the Conference on Legal,

Security and Privacy Issues in Information Technology. That article received the 2008 Best Paper Award from the Journal of International Commercial Law and Technology.

All articles are single-authored by the PhD candidate. They reflect the author's personal research and opinions. All research articles are the individual work of the author and do not necessarily reflect IBM's or any other third party's understanding of the subject matter and opinion.

Literature has been reviewed up to the submission dates of the individual articles (see Part Two). Referencing is according to the American Psychological Association (APA) style, 5th edition.

Thesis Evaluation Requirements for the DBA Programme

The requirements and acceptance criteria relevant for the successful completion of the *DBA programme* are the same as for the regular full time PhD programme. They read as follows:

“1. Ability to ask research questions that are interesting and that contribute to knowledge. A researcher should be able to pick either theoretically interesting or challenging problems (including wicked problems or messes), or starting with empirical observations wanting to explain a particular phenomenon. Raising a good research question is important to see if a candidate can identify interesting problems that deserve further research. A good research question should connect to existing knowledge. It is also important that the (wicked) problem or mess is formulated in a way that is researchable.

2. Knowledge of current literature within the field, and ability to critically discuss the state of knowledge within a field. Doing a literature review a candidate should be able to cover how similar questions have been dealt with earlier in the literature. Based on this review the candidate should be able to choose a theoretical venue that is promising to explain the phenomenon under investigation. Here the researcher should be able [to] choose appropriate theories that should be critically discussed. Based on a critical assessment of current knowledge of a field, the research should point out gaps in the knowledge and how these can be filled. This is a stage where the researcher identifies the goals for contributing to knowledge.

3. Ability to formulate theory and models (where applicable), and state hypotheses (where applicable). Different research paradigms have various requirements for how research should be done. [...] In this evaluation [the assessors] do not rate one form above another, [the assessors] will basically follow what the researcher does, and evaluate to what

extent these criteria are [ful]filled. [The assessors] are not personally holding any research paradigms or theories as better than others, [the assessors] evaluate how the candidate, given his point of departure, achieves the goals and requirements of the chosen paradigm, and to what extent the data and analyses support the theory. [The assessors] will, however, look for missed opportunities in theory development.

4. Ability to make appropriate research designs, use appropriate methods for gathering and analyzing data, and communicate the methods so that it is possible to replicate the study. Research designs should enable researchers to answer the questions they ask, therefore, [the assessors] will evaluate to what extent the candidate has set up a research design that enables the candidate to draw the conclusions that are raised, and how effectively the design is used. It is also important to draw the conclusions that are raised, and how effectively the design is used. It is also important to design research in a way that makes refutation of hypotheses possible. [The assessors] will also emphasize the extent to which the candidate is able to communicate the methods so that other researchers can evaluate or replicate [the candidate's] thesis. Most importantly, to what extent does the candidate master his methodology, and how does it fit into the reporting of results. [...]It is also important to judge [the candidate's] abilities as an empirical researcher, and how [the candidate] has been able to take advantage of the methods getting the data [that the candidate] needs, and to what extent [the candidate] also sees the limitations of the methods.

5. Ability to present results, analyze data, and evaluate the validity and reliability of the data and results. Presenting results requires that the candidate [have] good data, and a way of organizing the presentation so that [the candidate] can show and convince readers that [the candidate's] story reflects the empirical setting in a correct way. This requires showing documentation that can support the story

and interpretations of the data. Doing quantitative analyses and statistical testing requires not only mastering the statistics and mathematical modeling supporting the results, but also to know their strengths and limitations.

6. Ability to draw valid conclusions and discuss research findings compared to the current state of knowledge, and [to] show clearly what contribution this research has made to our knowledge. This requires the candidate to see how [the candidate's] empirical data can be translated into valid theoretical statements and recommendations that either support or modify the current theories or models. It is crucial to show what theoretical contributions the research has made. Here it is also important to discuss external validity and generalizability of the study.

7. Ability to show limitations of the research and directions for further research. All research has some limitations. These can be located in the research design, the available data or the representativeness of the respondents. To show competence in this area, a researcher should be able to not only see limitations, but [to] also discuss under what circumstances the research is valid, and to what extent it is possible to make generalizations. Discovering what are the shortcomings of the current research should also enable the candidate to formulate new research questions that can direct further research for [the candidate] or others. The quality of these research questions shows the extent to which the candidate understands the limitations of [the candidate's] own research.

8. Ability to handle epistemological paradigms that may be of importance for the research. The researcher should show which epistemological paradigm(s) [the candidate] chooses and uses. [The assessors] will, however, look for missed opportunities in use of paradigms." (pp. 1-3; emphases omitted) (Rasmussen, Henschel, & Sol, 2009, unpublished).

Content Overview

PART ONE	1	
Chapter 1	Introduction	3
Chapter 2	Radio Frequency Identification	21
Chapter 3	Innovation and Regulation	41
Chapter 4	Research Method	63
Chapter 5	Data Collection	83
Chapter 6	Observations	97
Chapter 7	Discussion	111
Chapter 8	Conclusion	129
References		139
Appendix 1	Excerpt of Coding Sheet for Concept Article	163
Appendix 2	Interview Template for Survey Article	165
Appendix 3A	Excerpt of 1 st Interview Transcript with Company A	168
Appendix 3B	Excerpt of 2 nd Interview Transcript with Company B	181
Appendix 3C	Excerpt of 3 rd Interview Transcript with Company C	192
Appendix 4	Online Survey for Survey Article	202
Appendix 5	Results of Online Survey (Raw Data)	206
Appendix 6	Characteristics Used in Journal Articles on Adoption and Diffusion of IT, EDI and RFID as Technological Innovation	216
Glossary		224
PART TWO	227	
1. Database Article		229
2. Marketing Article		245
3. Modality Mix Article		271
4. Survey Article		297
5. Concept Article		331

Table of Content

PART ONE	1
Chapter 1 Introduction	3
1.1 RFID and the Internet of Things	3
1.2 Research Approach	6
1.3 Research Method	10
1.4 Research Contribution	12
1.5 Research Overview	13
1.6 Research Bandwidth	17
1.7 Thesis Structure	18
1.8 Chapter Summary	19
Chapter 2 Radio Frequency Identification	21
2.1 Pervasive Computing	21
2.2 RFID Technology	23
2.3 RFID Standards	30
2.4 RFID Equipment	33
2.5 RFID Applications	35
2.6 Chapter Summary	40
Chapter 3 Innovation and Regulation	41
3.1 Innovation	41
3.2 Regulation	51
3.3 Chapter Summary	61
Chapter 4 Research Method	63
4.1 Two Dimensions – Four Paradigms	63
4.2 The Four Schools of Thought Applied	67
4.3 Inverting the Approach	71
4.4 Paradigm Incommensurability	77
4.5 Pragmatism	78
4.6 Abduction	79
4.7 Chapter Summary	82
Chapter 5 Data Collection	83
5.1 Paradigm Mix	83
5.2 Database Article	85
5.3 Marketing Article	85
5.4 Modality Mix Article	86

5.5	Survey Article	86
5.6	Concept Article	88
5.7	Caveat for the Interpretation of the Survey Data	89
5.8	Chapter Summary	95
Chapter 6	Observations	97
6.1	Observation 1: Database Article	97
6.2	Observation 2: Marketing Article	100
6.3	Observation 3: Modality Mix Article	103
6.4	Observation 4: Survey Article	107
6.5	Chapter Summary	109
Chapter 7	Discussion	111
7.1	Characteristics of Technological Innovation in IS Research	111
7.2	Lack of Legal Perspectives in IS Research	122
7.3	Lack of Diversity in Regulation of Technological Innovation in IS Research	125
7.4	Chapter Summary	127
Chapter 8	Conclusion	129
8.1	Observation 1 and Hypothetical Claim 2	129
8.2	Observation 2 and Hypothetical Claim 1	131
8.3	Observation 3 and Hypothetical Claim 2	132
8.4	Observation 4 and Hypothetical Claim 1	133
8.5	When Bits Learn to Walk Don't Make Them Trip	134
8.6	Future Research	136
References		139
Appendix 1	Excerpt of Coding Sheet for Concept Article	163
Appendix 2	Interview Template for Survey Article	165
Appendix 3A	Excerpt of 1 st Interview Transcript with Company A	168
Appendix 3B	Excerpt of 2 nd Interview Transcript with Company B	181
Appendix 3C	Excerpt of 3 rd Interview Transcript with Company C	192
Appendix 4	Online Survey for Survey Article	202
Appendix 5	Results of Online Survey (Raw Data)	206

Appendix 6	Characteristics Used in Journal Articles on Adoption and Diffusion of IT, EDI and RFID as Technological Innovation	216
Glossary		224
PART TWO		227
1.	Database Article	229
2.	Marketing Article	245
3.	Modality Mix Article	271
4.	Survey Article	297
5.	Concept Article	331

Figures

Figure 1:	US Patent 3 713 148, Figures 1, 2, 3	4
Figure 2:	Thesis structure	19
Figure 3:	Number of articles referencing the three concepts of interest in this thesis in the years 1990-2006	22
Figure 4:	Overview and selection of Auto-ID systems	24
Figure 5:	Simplified example of an RFID system	25
Figure 6:	Overview of EPCglobal standard	33
Figure 7:	Cat with RFID reader showing identification number	38
Figure 8:	Cat entering through cat door that can be RFID-enabled	38
Figure 9:	Paradigm quadrant with examples of schools of thought	64
Figure 10:	Relationship of induction and deduction	80

Tables

Table 1:	Relationship between research question, research articles, observations (O 1 – O 4), hypothetical claims, and conclusion	11
Table 2:	Overview of the research articles	16
Table 3:	Qualitative summary of attributes applied to all concepts	22
Table 4:	RFID tag characteristics	26
Table 5:	Summary of power supply and tag functionality	28
Table 6:	Selected ISO standards	32
Table 7:	Different RFID tags, antennas, and readers	34
Table 8:	Summary of examples of RFID pilots and implementations	40
Table 9:	Overview of selected theoretical and empirical work on the adoption and diffusion of technological innovation	51

Table 10:	Extension of the different terminologies for the same modalities of regulation	58
Table 11:	Summary of technological innovation of RFID and RFID regulation by law, each in the narrow and the wide sense	72
Table 12:	Summary of meta-theoretical assumptions and paradigm allocation	77
Table 13:	Examples of deduction, induction, and abduction	81
Table 14:	Summary of survey invitations and replies	94
Table 15:	Summary of the research methods of the individual article	96
Table 16:	Matrix proposal for the distribution of regulation by law to other modalities of regulation	106
Table 17:	Summary of observations	109
Table 18:	Summary of characteristics in IS research on IT, EDI and RFID	123
Table 19:	Relationship between the conclusion, the hypothetical claims, the observations (O 1 – O 4)	130

Observations

Observation 1	100
Observation 2	102
Observation 3	107
Observation 4	109

Equations

Equation 1: Sample size	93
Equation 2: Sample size	94
Equation 3: Margin of error	95

Hypothetical Claims

Hypothetical Claim 1	124
Hypothetical Claim 2	127

Charts

Chart 1:	Survey question 3	206
Chart 2:	Survey question 4	207
Chart 3:	Survey question 5	207
Chart 4:	Survey question 6a	208
Chart 5:	Survey question 6b	208
Chart 6:	Survey question 6c	209
Chart 7:	Survey question 7a	209
Chart 8:	Survey question 7b	210
Chart 9:	Survey question 8a	210
Chart 10:	Survey question 8b	211
Chart 11:	Survey question 8c	211
Chart 12:	Survey question 12	212
Chart 13:	Survey question 13a	213
Chart 14:	Survey question 13b	213
Chart 15:	Survey question 13c	214
Chart 16:	Survey question 14	214
Chart 17:	Survey question 16	215

PART ONE

INTRODUCTION AND OVERVIEW

Chapter 1

Introduction

Chapter 1 introduces the research project of this thesis. First, a brief (historical) introduction of Radio Frequency Identification (RFID) and the Internet of Things is offered (Section 1.1). Second, the research approach and the overall research question are stated (Section 1.2). The research method is outlined (Section 1.3) and the research contribution is suggested (Section 1.4). An overview of the research findings of five individual research articles is presented (Section 1.5). The research bandwidth, i.e., delimitation, is suggested in Section 1.6. Finally, the structure of this thesis is presented (Section 1.7).

1.1 RFID and the Internet of Things

As the name suggests, RFID is a technology that enables automatic identification and data capture via radio frequency. An RFID tag can contain information about an object, animal, or person, to which it is attached or linked (___, 2007). This information can be transmitted wirelessly to an RFID reader. Subsequently the information can be used in many different ways by (back-end) information technology (IT) infrastructure. As groundbreaking as the identification of objects might seem, the history of RFID is older than one might expect. The genesis of RFID is attributed to the founders of the electromagnetic wave theory (Hawrylak, Mickle, & Cain, 2008): the chemist and physicist Michael Faraday (1791 – 1867), the physicist James Clerk Maxwell (1831 – 1879), and the physicist Heinrich Rudolf Hertz (1857 – 1894). Faraday's law and the Ampere-Maxwell law form the basis of near-field RFID systems. Hertz was able to verify Maxwell's work on electromagnetism and discovered radio waves. This was the advent of many radio-based applications. Allegedly, US president Franklin D. Roosevelt furthered his political career via radio; and radar – radio detection and ranging (see Section 2.2.2) – was employed in World War II as identification device of combat airplanes (IFF system: identify friend and foe) (Hawrylak, Mickle, & Cain, 2008).

An RFID patent of January 23, 1973 granted by the United States Patent and Trademark Office (Figure 1) claims as follows:

“A novel transponder apparatus and system is disclosed, the system being of the general type wherein a base station transmits an ‘interrogation’ signal to a remote transponder, the transponder responding with an ‘answerback’ transmission. The transponder includes a changeable or writable memory, and means responsive to the transmitted interrogation signal for processing the signal and for selectively writing data into or reading data out from the memory. The transponder then transmits an answerback signal from the data read-out from its internal memory, which signal may be interpreted at the base station. In the preferred inventive embodiment, the transponder generates its own operating power from the transmitted interrogation signal, such that the transponder apparatus is self-contained.” (abstract) (Cardullo & Parks (III), 1973).

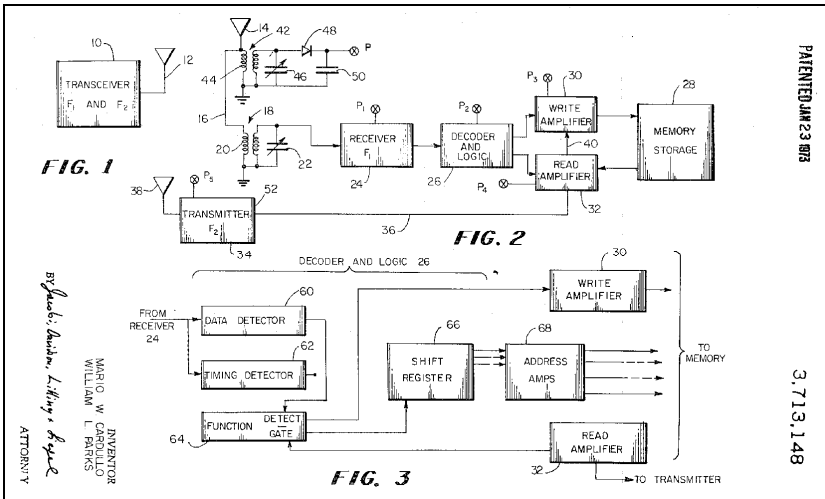

Figure 1: US Patent 3 713 148, Figures 1, 2, 3 (Cardullo & Parks (III), 1973).

Hence, RFID technology itself is not new. But in the past decade, the adoption and diffusion of RFID have moved into new application and operational areas. Therefore the choice and qualification of RFID as technological¹ innovation to be studied is appropriate, precisely because of this emergent use and implementation.

Ever since its invention has RFID technology gained popularity in the identification of objects, for instance, as identification device in fast lane highway toll collectors; as identification for cattle and pets; as replacement for the barcode in supply chain management or retail; lately also as technology for real time location services (RTLS); or as identification device for the (future) Internet of Things. The Internet of Things is a network of communicating devices that can interact in context of the physical world (Buckley, 2006). It is noted that the Internet of Things describes an area of great potential:

“The term ‘Internet of Things’ has come to describe a number of technologies and research disciplines that enable the Internet to reach out into the real world of physical objects. Technologies such as RFID, short range wireless communications, real-time localization, and sensor networks are becoming increasingly common, bringing the ‘Internet of Things’ into industrial, commercial, and domestic use.” (p. V) (Floerkemeier, Langheinrich, Fleisch, Mattern, & Sarma, 2008).

It has been confirmed that RFID technology functions as a key pace-setter in the Internet of Things (Goerdeler, et al., July 2007). Furthermore, RFID is likely to be the cornerstone of the Internet of Things (European Commission Information Society Media, 2008). RFID is one step towards pervasive computing (see Section 2.1), which, because of technology convergence, may lead to a seamless integration of the physical world with cyberspace (see Section 1.2.1) (Van de Voort & Ligtoet, 2006). It is anticipated that many common physical objects will adopt RFID tags and will interact with each other and with the Internet. Objects will learn to talk; bits will learn to walk. It

¹ For Part One of this thesis the term “technological” is favoured over the term “technical”. The former is understood by the author to cover both hardware and software components, whereas the latter is only hardware based.

is proposed in this thesis that a balance be found between technological innovation and regulation to prevent these bits from tripping.

1.2 Research Approach

The title of this thesis “When Bits Learn to Walk Don’t Make Them Trip. Technological Innovation and the Role of Regulation by Law in Information Systems Research: The Case of Radio Frequency Identification (RFID)” includes two main scientific topics: technological innovation and regulation. The combined articulation of these two words begs the questions whether there is a link between technological innovation in general – hence, RFID in specific – and regulation.

1.2.1 Technological Innovation and RFID

Information and Communications Technology (ICT) is more than “just” the Internet, although it is often (erroneously) used as virtual synonym for the Internet. ICT should include all modern technologies used for electronic data-processing technologies that store, transmit and process information. As such it encompasses, for instance, computers in general, telecommunications, broadcasting, and networks. In the past decades, telecommunications and broadcasting, part of the underlying ICT infrastructure, have been regulated by national governments. The IT sector, however, has not been regulated in the same way. The convergence of technologies, such as in this instance, RFID, which joins telecommunication technology with Internet technology, calls into question whether these convergence developments qualify for the same regulatory treatment (Lips, 2006b).

From the introduction of the RFID technology in Chapter 2, it is evident that RFID is a form of ICT. RFID contains information, it communicates (such information), and it is undisputedly a piece of technology. Therefore, it seems reasonable to explore the link between technological innovation and RFID based on the examples of ICT and cyberspace in specific. Cyberspace – a combination of

cybernetics and space, also known as the Matrix² – is relevant because in this context it is often used as synonym for the Internet (Barlow, 1996). Objects tagged with RFID are and will be linked to the Internet – the Internet of Things (see Section 1.1).

1.2.2 Technological Innovation and Regulation

Brownsword (2008) notes that by experience technological innovations develop and move on in ways that create difficulties for regulation. The outstanding generic challenge is the connection between technological innovation and regulation. Whereas innovation refers to the unknown, the not yet existing, the surprising new; regulation refers to a specific scope and fosters the realisation of a final state (Eifert, 2008). Similarly, it is questioned how public tenders can foster innovation. Public tenders follow strict regulation to enable the allocation of the economically most efficient offer, and to assure equal opportunities (Fehling, 2008). Innovation is, however, not necessarily driven by the economically most efficient allocation. Or how a regulator shall pursue “the holy grail of reconciling the requirements of certainty and flexibility, of precision and generality” (p. 95) (Black, 1999). Or, as Brownsword (2008) put it, there is “a tension between the need for flexibility (if regulation is to move with the technology) and the demand for predictability and consistency (if regulatees are to know where they stand)” (p. 287). Thus, there seems to be an antagonism between technological innovation and regulation by law.

Regulation of innovation is regulation of knowledge (Bora, 2008). A significant challenge for regulation of innovation is the *lack* of knowledge with regard to the anticipated innovation (Rodi, 2008). Thereby the problem of any regulation of knowledge is the risk of a decision inherently linked to any regulation: the constitutive insufficiency of adoption and diffusion of innovation must be accepted

² “The matrix has its roots in primitive arcade games [...] in early graphics programs and military experimentation with cranial jacks. [...] Cyberspace. A consensual hallucination experienced daily by billions of legitimate operators, in every nation, by children being taught mathematical concepts...A graphic representation of data abstracted from the banks of every computer in the human system. Unthinkable complexity. Lines of light ranged in the nonspace of the mind, clusters and constellations of data. Like city lights, receding...” (p. 51) (Gibson, 1984).

as such for the establishment of regulation. Regulation of innovation is both impossible and necessary at the same time (Bora, 2008). Three viewpoints shall underscore the disconnection:

First, nowadays, technological innovations advance quicker than law (Koops, 2006). Or as Braithwaite (1984) formulated:

“The problem with [laws] is that they [...] have to be constantly updated to keep pace with scientific advances. Science always changes faster than any form of law because, by design, law aims for stability whereas science aims at growth and transformation by revolutionary paradigm shifts.” (p. 311) in: Brownsword (2008).

Various activities undertaken in the Internet are leading governments to review the enforceability of existing regulation by law. The applicability of existing legal frameworks is debated and the regulatory approach towards the range of technological innovations is rethought (Lips, 2006a).

Second, with regard to the Internet, Barlow noted the following disconnection:

“Faith in law will not be an effective strategy for high tech companies. Law adapts by continuous increments and at a pace second only to geology in its stateliness. Technology advances in the lunging jerks, like the punctuation of biological evolution grotesquely accelerated. Real world conditions will continue to change at a blinding pace, and the law will get further behind, more profoundly confused. This mismatch is permanent.”

Whereas this statement seems exaggerated, in principle it is correct. The disconnection can be viewed as either descriptive in that the descriptions employed by regulation no longer correspond to the technology or its practices; or normative in that the technological innovation raises doubts as to the value underlying the regulatory scheme (Brownsword, 2008).

Lastly, a society that accepts technological innovation runs the risk of future negative implications if the positive effects of the adoption and

diffusion of the technological innovation are consumed by negative effects of such technological innovation. To the extent that regulation can be viewed as instrument to mitigate the negative effects of adoption and diffusion of technological innovations, it stands not only in contrast to technological innovation but also has the reputation of being innovation impeding. Jurisprudential innovation research does, however, recognise that imperative law can also stimulate innovation, for instance, through the constitutional basic right of liberty (Calliess, 2008). At any rate, at least there is debate whether regulation impedes or stimulates innovation.

1.2.3 Research Question

The three statements in the preceding sub-section on the possible disconnection between technological innovation and regulation do not reveal anything yet about the solution. Why this disconnection exists, whether it is necessary to change regulation by law, or whether it is suggested to use other means of regulation will be addressed tentatively in this thesis. For the avoidance of doubt, a regulatory disconnection is not necessarily a bad thing that needs to be amended (i.e., close the gap) under all circumstances (Brownsword, 2008). The fact remains, however, that a disconnection between technological innovation and regulation by law is perceived. The assumption is made that if there is a disconnection, there is likely a misbalance. This thesis attempts to address the issue of a successful balance between technological innovation and regulation by law in the adoption and diffusion of RFID.

Adoption and diffusion of technological innovation in general, and RFID in specific, are an interesting yet complex topic. Many factors affect the adoption and diffusion of technological innovation. Identifying these factors and understanding their interactions is important. These factors influence the success of the adoption and diffusion of technological innovation. Technological advances can increase the complexity and uncertainty of the adoption and diffusion of innovation. This can lead to a dependency on experts who in turn build new knowledge hurdles for potential innovation adopters (Attewell, 1992).

Many scholars related to IS research innovation from a technology, economy, or organisation perspective. There is considerable research

on the adoption and diffusion of information and communication technologies (ICT) (see Sections 3.1 and 7.1). To the best of the author's knowledge, however, little research has been conducted so far in the IS community on the influence of regulation by law in IS. By means of RFID as a use case, this thesis shows the shortcomings in the relation between technological innovation and regulation. Knowing that more research will be necessary, this thesis answers the overall *research question*:

<p>Research Question: How can the adoption and diffusion of RFID be balanced successfully between technological innovation and regulation by law?</p>
--

As understood in this thesis, a successful balance shall mean that, on the one hand side, there should not be impeding regulation which would stifle the adoption and diffusion of RFID; on the other hand, the adoption and diffusion of RFID should not allow governments or the industry any exploitation of Orwellian dimensions. Thus, a successful balance should be found by weighing the benefits and risks of the adoption and diffusion of RFID.

1.3 Research Method

To answer the research question, the reasoning in this thesis is based on abduction – besides deduction and induction the third method of reasoning. The research method comprises several components: one overall research question; five research articles, of which four generate observations (O_n) used as surprising facts of the first premise of abductive reasoning; two hypothetical claims used as second premise in the abductive reasoning; and the conclusion as third premise of the abductive reasoning. Abduction is described in more detail in Sections 4.5 and 4.6.

Table 1 shows the relationship between these components.

Research Question How can the adoption and diffusion of RFID be balanced successfully between technological innovation and regulation by law?				Research Method Abduction
Marketing Article	Survey Article	Database Article	Modality Mix Article	1 st premise
O 2 Extending the doctrinal definition of active RFID tags to include reader-independent and indiscriminate signalling might lead to unfavourable regulation by law.	O 4 The interactions between, and consequently also the exchange of expert know-how and standpoints of, (i) the RFID industry and the legal regulator and (ii) the RFID industry and the consumers seem insufficient.	O 1 Despite the amount of data anticipated to be stored and the regulation by law in the different countries where RFID is adopted and diffused, the location of the databases containing RFID data does not seem to play an important role for the technological innovator.	O 3 The current adoption and diffusion of RFID technology do not seem to be following an appropriate mix of regulation.	
Hypothetical Claim 1 Lack of legal perspective in IS research.		Hypothetical Claim 2 Lack of diversity in regulation of technological innovation in IS research.		
Conclusion				3 rd premise

Table 1: Relationship between research question, research articles, observations (O 1 – O 4), hypothetical claims, and conclusion; including 3 premises of abduction.

As shown in Table 1, the structure and development of this thesis leads from the initial research question at the beginning of the research project, over the four observations made in each one of the four research articles of this paper-based thesis (the research of the fifth article on pervasive computing blends into the technological foundation of Chapter 2), to the two hypothetical claims, and finally to the concluding inference. The column on the far right side of Table 1 shows the research method and the allocation of the three premises of abductive reasoning.

1.4 Research Contribution

This thesis is submitted at the PhD School of Informatics because (i) RFID as technology falls within the research field of ICT; (ii) the main theory is focused on the adoption and diffusion of technological innovation; and (iii) the overall research question relates to regulation in technological innovation, not vice versa. This justified choice, however, does not suggest that the findings are irrelevant for legal experts; by all means not. After all, this thesis seeks an answer to the research question of how to balance two distinct scientific disciplines and research areas. Unless shortcomings are only identified in one research area – which, as one might anticipate, they are not – then the addressees of this thesis are found in both research areas of technological innovation and law. Hence, it is argued here that changes in both ICT and law are necessary for a successful adoption and diffusion of RFID technology. Little, if anything at all, seems to speak against the proposal that this thesis be interdisciplinary.

It is suggested that the four cases (conclusions) built in this thesis provide a solid foundation for the following four hypotheses that can be further tested with additional empirical data. They can, for instance, be verified or falsified by IS or legal researchers:

1. Increasing the diversity of regulation modalities has a positive effect on the strategic management decisions for the deployment location of technological innovation.
2. Increasing the legal perspective in IS research has a positive effect on the marketing strategy for technological innovation.

3. Increasing the thoroughness and precision in the review of essential regulation by law has a positive effect on other regulatory tools for technological innovation.
4. Increasing the legal perspective in IS research has a positive effect on the industry's awareness of the legal challenges and their consequences.

1.5 Research Overview

This thesis is paper-based. Five individual topics were researched and published in / submitted to law and technology journals:

1. Databases that register the data of an RFID tag lie at the heart of an RFID system (___, 2007). The storage and handling of the collected data, including its use by third parties, are therefore of particular interest. A first journal article entitled *The Absence of Legal Database Protection in the EPCglobal Network* looks at the EPCglobal network and the efficient system for the deployment and administration of RFID in supply chain management (Ronzani, 2007).

The partly decentralised structure of the EPCglobal network triggers questions about data compiled in the EPC information system (EPCIS) and in databases containing RFID data (in RFID databases). The research article aims at directly applying the rulings of the landmark cases on copyright and database protection Feist (USA), CCH (Canada), and *Horsereading / Fixtures* (European Union) for RFID data compiled in the EPCglobal network. It observes and suggests that there is no strategic legal advantage in the placement of RFID databases for the adoption and diffusion of RFID. For the remainder of this thesis that article is referred to as *Database Article*.

2. A published conference proceeding analyses why marketing short-range devices as RFID might backfire on the RFID industry. The relevance of this article results from the necessity to review the way the industry adopts and diffuses RFID as technological innovation and how regulation by law supports RFID as technology.

The observation why marketing short-range devices as RFID might backfire on the RFID industry results from an analysis of 43 legal articles. The article entitled *Why Marketing Short-Range Devices as Active Radio Frequency Identifiers Might Backfire* shows that legal experts still perceive the technology of RFID in an undifferentiated way (Ronzani, 2008b). An analysis of 11 RFID tag providers of so-called “active RFID tags” shows that short-range devices are marketed as active RFID. It concludes that to avoid inhibiting legal consequences, which might have a negative effect on the RFID industry, a differentiated approach regarding the functionality of short-range transmitters and RFID is necessary. For the remainder of this thesis that article is referred to as *Marketing Article*.

3. A third journal article entitled *Modality Mix of RFID Regulation* analyses RFID regulation based on four modalities, namely, law, norms, market, and architecture by Lessig (1999) (Ronzani, 2008a). The relevance of this article results from the awareness that the adoption and diffusion of RFID cannot be regulated solely by law.

This research article observes and suggests that a trade-off between, or complementing of, the four modalities is necessary for a holistic regulation of the adoption and diffusion of RFID as technological innovation. The observation is made by cross-examination of various topics of the draft recommendation on the implementation of privacy, data protection and information security principles in RFID applications by the European Commission of February 2008 (Draft Recommendation, 2008) with, and attributed to, one of the four modalities of regulation. This research article concludes that the Draft Recommendation (2008) does not provide precise supplementing legislation to justify its implementation. Many law-related issues of the Draft Recommendation (2008) can be regulated more successfully by the other three modalities, namely, norms, market, and architecture. For the remainder of this thesis that article is referred to as *Modality Mix Article*.

4. A limited amount of empirical data has been collected and discussed in a research article entitled *Legal Regulation and Consumers: The RFID Industry's Perspective* (Ronzani, 2009b).

The relevance of this article results from the author's proposal that the industry take a good look at itself and critically assess the necessary steps for a successful and balanced adoption and diffusion of RFID.

A worldwide survey of 111 stakeholders of the RFID industry, which is evaluated by different geographical regions and industries, observes that the RFID industry needs to do some homework to promote its technological innovation in ways favourable to the RFID business. It is suggested in this article that the RFID industry engage in a more constructive dialogue with the legal regulator, strengthen its knowledge on applicable legislation, and re-evaluate its information policy to the general public. For the remainder of this thesis that article is referred to as *Survey Article*.

5. Finally, a research article entitled *The Battle of Concepts: Ubiquitous Computing, Pervasive Computing and Ambient Intelligence in Mass Media* covers the concept of pervasive computing (Ronzani, 2009a). The relevance of this article results from the different concepts that surround RFID as technology.

This article studies how the three concepts of ubiquitous computing, pervasive computing, and ambient intelligence have evolved (or not evolved) through and in mass media. It suggests (i) that by and large the three concepts are described by the same attributes and can be used interchangeably; and (ii) that print mass media (newspapers) play a specific role in the adoption and diffusion of RFID. For the remainder of this thesis that article is referred to as *Concept Article*.

Whereas, as noted earlier, the four observations in the Database Article, Marketing Article, Modality Mix Article, and Survey Article are used as first premise of the abductive reasoning, the Concept Article is reflected in the technological foundation of RFID in Chapter 2.

Table 2 gives an overview of the five articles and the means of publication:

Article	Title	Presentation and Publication Level
1. Database Article	The Absence of Legal Database Protection in the EPCglobal Network	<p>Presentation at: International Conference on Business, Law and Technology, Copenhagen, December 5-7, 2006.</p> <p>Published in: International Journal for Intellectual Property Management, Vol. 1, Issue 4, pages 341 – 350.</p> <p>URL: http://www.iblt.eu/IBLT2006</p>
2. Marketing Article	Why Marketing Short-Range Devices as Active Radio Frequency Identifiers Might Backfire	<p>Presentation at: International Conference on the Internet of Things (IOT) 2008, Zurich, March 26-28, 2008.</p> <p>Published in: The Internet of Things, LNCS 4952, Springer, Berlin Heidelberg 2008, pages 214 – 229.</p> <p>URL: http://www.iot2008.org</p>
3. Modality Mix Article	Modality Mix of RFID Regulation (JICLT best paper award 2008)	<p>Presentation at: International Conference on Legal, Security and Privacy Issues in IT (LSPI), Prague, September 3-5, 2008.</p> <p>URL: http://www.lspi.net</p> <p>Published in: International Journal for Commercial Law and Technology, Vol. 3, No. 4, pages 222 – 232.</p> <p>URL: http://www.jiclt.com</p>
4. Survey Article	Legal Regulation and Consumers: The RFID Industry's Perspective	Variation of this article to be submitted mid November 2009 for review as book chapter.
5. Concept Article	The Battle of Concepts: Ubiquitous Computing, Pervasive Computing and Ambient Intelligence in Mass Media	<p>Published in: Ubiquitous Computing and Communication Journal (UBICC), Vol. 4, No. 2, article 2, pages 1-11.</p> <p>URL: http://www.ubicc.org</p>

Table 2: Overview of the research articles.

1.6 Research Bandwidth

Research of RFID technology addresses many topics, for instance, technological features, privacy and security measures, governance of databases, availability of radio spectrum, harmonisation of international standards, health and environmental impact, and social as well as ethical implications (____, 2007). However, as in any thesis research the scope must be narrowed to a specific research question. The research question for this thesis has been formulated in Section 1.2. To answer the research question, this thesis focuses on the interdisciplinary research of IS and regulation. Within the realm of IS, the adoption and diffusion of technological innovation are of interest. Within the realm of regulation, law is of interest.

Limitations to this research are given partly by the interdisciplinary scope of the research question, partly by the combined academic and industrial scope of the DBA programme, and partly by the limited means available to this privately financed research project. The following delimitations are proposed:

First, regulation of ICT can refer to law, social norms, market, and architecture (Lessig, 1999; Scott, 2004; Bronwen & Yeung, 2007). The analysis of this thesis, however, focuses primarily, but not solely, on regulation by *law* (for details see Chapter 1). Regulation by social norms, market and architecture are reflected on to show the advantages or shortcomings of regulation by law in IS and to show the possibility of other means of regulation. Of the regulation by law that seems most relevant for the regulation of RFID – frequency law, database law, and privacy law – no one single field of law is singled out for this research. It is claimed that there is already a large body of research in these fields of law. Instead, the approach in Part One of this thesis is to look at regulation by law from a higher, more generic perspective to arrive at four distinct observations.

Second, Europe and the USA are, among others, strong competitors in ICT (Goerdeler et al., July 2007). The research of this thesis is territorially and jurisdictionally limited to Europe and North America to allow a direct comparison between the two regions: International Technology Union regions 1 and 2 (ITU, 2005). Furthermore, the author's affiliation in Switzerland to IBM as US corporation fosters an

inter-territorial research approach. Finally, the language barrier to countries in Asia Pacific, ITU region 3 (ITU, 2005), would not allow a thorough review of the necessary data. As the Survey Article will show, there were some restrictions in the survey conducted globally.

1.7 Thesis Structure

This thesis consists of two major parts. Part One presents the overall research problem, major theories, such as, for instance, fancy intellectual tools like pragmatism (Stick, 1986) or abduction, and a literature review on technological innovation and regulation as well as a synthesis of the entire research project. Part Two presents the individual research contributions, i.e., the articles forming the research and observations.

The arrangement of Part One includes 8 chapters:

Chapter 1 introduces and presents the structure of this thesis. Chapter 2 covers the technological part and vests the reader with the necessary background knowledge on pervasive computing and RFID technology for understanding this thesis. It also offers a few examples of recent RFID implementations. The second chapter will be of interest to readers seeking more detailed information on the technological foundation of RFID. Chapter 3 gives an overview of innovation (ten innovation theories) and regulation (reasons and means). It is the definitional foundation of this thesis that is necessary to understand the observations and hypothetical claims. Chapter 4 covers the research methodology. It starts with a discussion on paradigms and schools of thought and offers an inverted philosophical reflection on RFID. Based on those findings it suggests a pragmatic approach based on abductive reasoning. Chapter 5 presents the collection of data from the five individual research articles. Chapter 6 summarises the individual research questions, individual frameworks, and individual observations of four research articles. It provides the first premise of abductive reasoning. Interested readers can go into more detail in the individual articles in Part Two of this thesis. Caution in interpreting the data should be taken. Chapter 7 stipulates the two hypothetical claims as second premise of abductive reasoning. It includes a literature review on IT, EDI, and RFID technology. Chapter 8 concludes this thesis by inference of the case from the observations

(result) and the hypothetical claims (rules). Further research based on the results of this thesis is suggested by formulating four hypotheses.

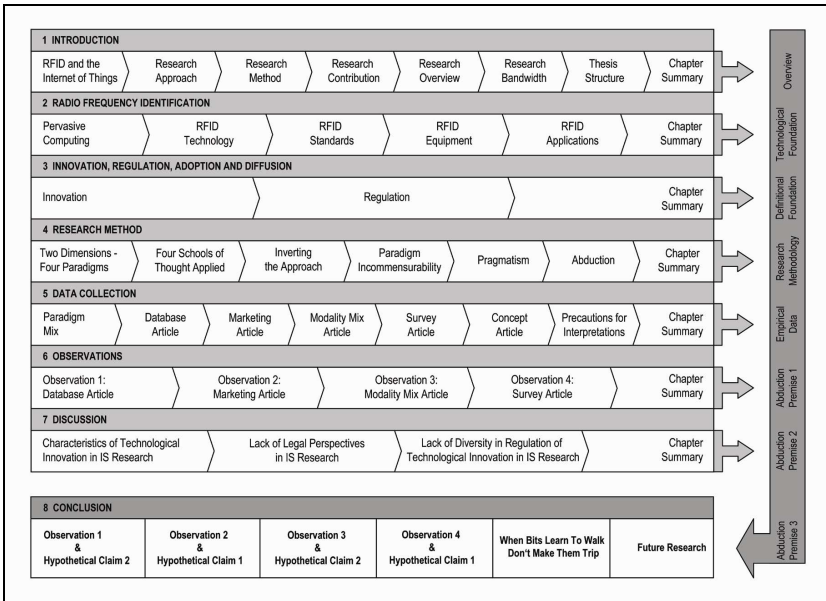

Figure 2: Thesis structure.

1.8 Chapter Summary

Chapter 1 introduces this paper-based research project. Foremost it states the *research question*, i.e., how the adoption and diffusion of RFID can be balanced successfully between technological innovation and regulation by law. It stipulates the scientific contribution. This chapter also introduces the research project. Finally, it provides the overall thesis structure.

Chapter 2

Radio Frequency Identification

Chapter 2 vests the reader with the knowledge about pervasive computing necessary to understand the observations and hypothetical claims of this thesis. First, it uses the findings of the Concept Article to argue in favour of the term pervasive computing (Section 2.1). Second, it provides an *overview* of RFID technology (Section 2.2). Thereafter it gives some *examples* of RFID standards (Section 2.3), equipment (Section 2.4), and applications (Section 2.5).

2.1 Pervasive Computing

In today's technology-based environment, unobtrusive wireless technology is often described by different concepts, such as ubiquitous computing, pervasive computing, or ambient intelligence. Xerox (PARC) introduced the concept of ubiquitous computing (Weiser, 1991), IBM coined the term pervasive computing (Hansmann et al, 2003), and Philips selected the expression ambient intelligence (IST Advisory Group, 1999). It has been suggested that the distinction between these terms remain purely academic (Mattern). The creators and sponsors of the three concepts ubiquitous computing, pervasive computing, and ambient intelligence, have seemingly used the concepts interchangeably. Research conducted based on 148 articles in eight distinguished UK, US, and Canadian newspapers (see Concept Article) indicates that whereas the number of articles on ubiquitous computing remains quite constant with about 4 articles on average per year as of 1990, sparking an increase in the years 1999 to 2001, there has been an exponential number of articles referring to the concept of pervasive computing during the so-called dot.com bubble (Figure 3). The results also show that the number of articles on ambient intelligence has been relatively low ever since its first occurrence in 1999, with less than one reference in a newspaper article per year on average (Ronzani, 2009a).

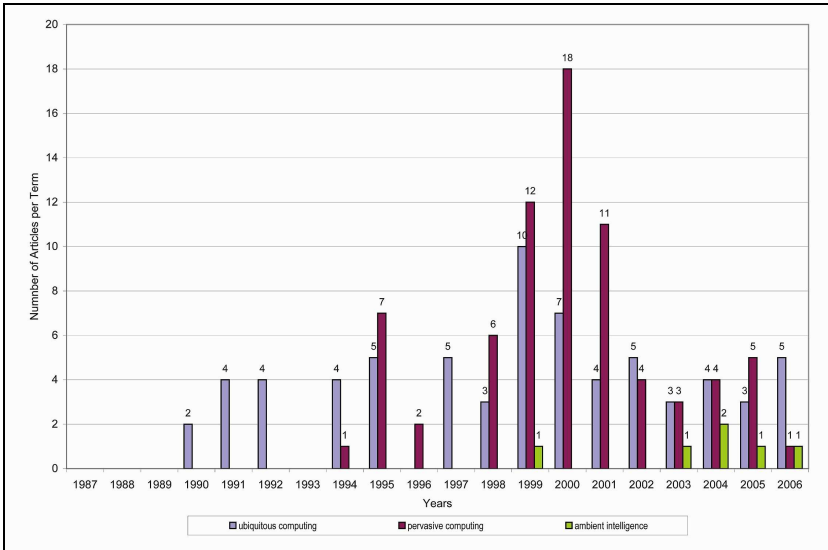

Figure 3: Number of articles referencing the three concepts of interest in this thesis in the years 1990-2006.

The qualitative analysis of newspaper articles reveals that the meaning ascribed to the concepts can be grouped into six attributes (Table 3): anywhere and anytime; home and leisure; business and work; networks; sensors; as well as intelligent and smart. These six attributes can be further grouped into two attribute *types*: (i) location, an attribute that answers the question “where?”; and (ii) means, an attribute that answers the question “how?”.

Attributes	Attribute type
1. Having access <i>anywhere</i> at <i>any time</i> ;	location: “where”
2. Using the technology for <i>business</i> or <i>work</i> ;	
3. Enabling the technology at <i>home</i> and for <i>leisure</i> ;	
4. Deploying the technology through <i>networks</i> ;	means: “how”
5. Applying <i>sensor</i> technology; and	
6. Making the environment <i>intelligent</i> and <i>smart</i> .	

Table 3: Qualitative summary of attributes applied to all concepts.

The dissemination of RFID-related concepts of ubiquitous computing, pervasive computing and ambient intelligence through mass media newspapers has *not* contributed to distinguishing these three concepts more precisely from one another. The research shows that all concepts are described by the same attributes and that there are variances in these concepts in that ubiquitous computing relates more to the work environment, pervasive computing more to networks, and ambient intelligence more to smart/sensor. But by and large, the concepts are used interchangeably.

A positive relationship between professional journal subscriptions (i.e., mass media) and innovativeness has been suggested (within software development groups) (Zmud, 1983). It has been concluded that channels of communication indeed affect the diffusion of expert systems: “[o]ne of the dominant factors in the external-influence model is the effect of mass media communication on the diffusion process” (p. 6) (Shao, 1999). It is claimed here that one reason the concept of ambient intelligence – to the extent it is currently being used – is only added to the repertoire of the other two concepts is that it has not been promoted sufficiently through the channel of mass media newspapers. Despite this concept being introduced in and promoted as of 1998, it has not replaced its rival concepts ubiquitous computing or pervasive computing (Ronzani, 2009a).

As noted by Mattern, the distinction between the three concepts of ubiquitous computing, pervasive computing and ambient intelligence remains purely academic. Precisely for this reason the concept of pervasive computing shall be used throughout this thesis.

2.2 RFID Technology

RFID is, like other identification systems, such as barcodes, biometrics, smartcards, and optical character recognition, one instance of an auto identification system (Figure 4). *Barcodes* allow a line-of-sight recognition of wide and narrow bars and gaps that can be read with a laser beam and interpreted numerically and alphanumerically (see B1 in Table 7). Currently there are about ten different barcode types. *Biometrics* is the procedure of identifying people by comparing unmistakable and individual physical characteristics, e.g., dactyloscopy, voice recognition, eye

identification. *Smartcards* comprise electronic data storage that is incorporated into a plastic card the size of a credit card (memory card or microprocessor card). They connect to a reader by galvanic connection to the surface contact. *Optical Character Recognition* (OCR) is an automatic identification system that allows the recognition of human-readable alphanumeric characters. In *RFID*, similar to the smartcard system, the data is stored on a data-carrying device (i.e., the RFID tag); unlike the smartcard system the data is exchanged via magnetic or electromagnetic fields (see Section 2.2.2), not via galvanic contacts (Finkenzeller, 2003; Finkenzeller, 2006). RFID can be combined with barcode systems to allow identification of objects by radio waves and by line-of-sight (see B1 in Table 7). RFID can also store and transmit biometric data (see Section 2.5). RFID can also be combined with smartcards.

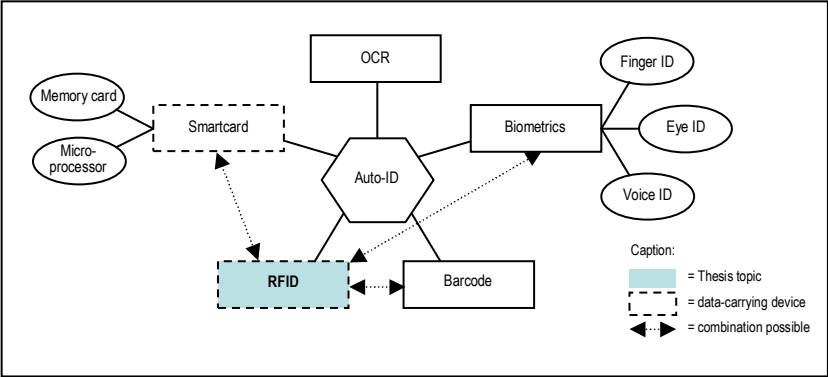

Figure 4: Overview and selection of Auto-ID systems (Finkenzeller, 2003; modified).

In its simplest form, an RFID system comprises two main components: (i) a transponder (i.e., a chip, tag, or transducer) that represents the actual data-carrying device; (ii) a reader that is capable of wirelessly identifying the information stored in the microchip of the transponder. For the end user to be able to access and use the data contained in an RFID transponder; and, (iii) a back-end system with the following additional hard- and software (Hawrylak, Mickle & Cain, 2008; Lahiri, 2006): a controller as an intermediary agent that allows

communication between a reader and an external entity; and a hard-, middle- and software system, e.g., servers and applications with intranet or Internet connection as well as a database. The database (Kifer, Bernstein & Lewis, 2006; Ramakrishnan & Gehrke, 2000) is necessary to store the information of, from, and related to the RFID-tagged items. Considering the business forecast of more than 220 exabytes³ of stored data by the year 2015 (European Commission Information Society Media, 2008) databases and storage architecture deserve technological and legal attention.

Figure 5 shows a simplified example of an RFID system. Objects 1 and 2 are equipped with (passive) RFID tags. When such (passive) tags are in the read range of an RFID reader they transmit the information contained in them to the RFID reader. This information is transferred to the back-end system where, for instance, it can be stored in the database, it can get information and be combined with data from the database, it can be transmitted within a closed systems (e.g., intranet or closed Internet), or it can be transmitted to the open Internet. A combination of the foregoing is possible.

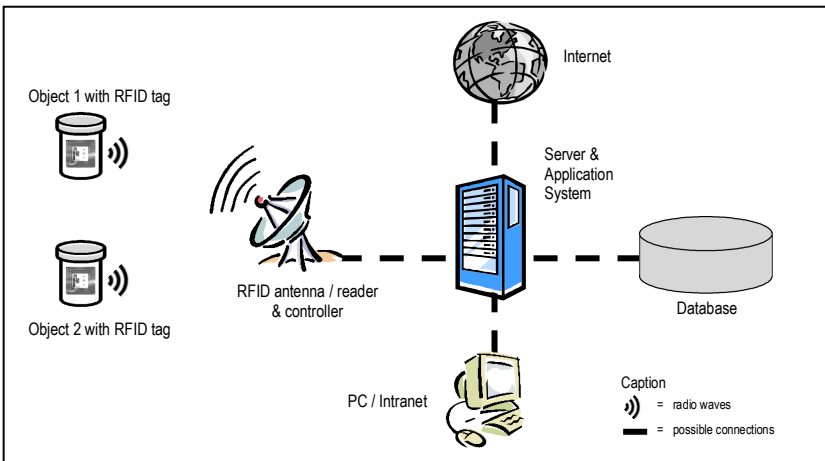

Figure 5: Simplified example of an RFID system.

³ 1 exabyte equals 10^{18} bytes. 220 exabytes correspond to the storage capacity of approximately 338'462'000'000 CD-Roms or 46'808'500'000 DVDs.

RFID systems differ in terms of their technological characteristics, such as frequency, storage capacity, energy supply, communication, coupling, and read range (Kern, 2006; Finkenzeller, 2006; Glover & Bhatt, 2006). Table 4 shows a selection of RFID tag attributes and their different characteristics.

Attributes	Characteristic of RFID tags		
Frequency	Low frequency (30 – 300 kHz: 135 kHz)	High frequency (3 – 30 MHz: 13.56 MHz)	Ultra high frequency (300 MHz – 3 GHz: 868/915 MHz ⁴) and Microwave (> 3 GHz: 2.45 / 5.8 GHz)
Memory and data	1-bit (no chip)	n-bit (chip with ID)	
<i>Energy supply of microchip</i>	<i>Passive</i>	<i>Semi-active/-passive</i>	<i>Active</i>
Communication	Full Duplex	Half Duplex	Sequential
<i>Coupling</i>	<i>Capacitive coupling (electrical coupling)</i>	<i>Inductive coupling</i>	<i>Backscatter coupling</i>
Read range	Close proximity: ≈ < 1 cm	Remote (or vicinity): ≈ 1 cm – 1 m	Long Range: ≈ > 1 m
Antenna	Coil	Ferrite	Dipole

Table 4: RFID tag characteristics; in *italics* are the two attributes described in detail in Sections 2.2.1 and 2.2.2 (Finkenzeller, 2006; Kern, 2006; Glover & Bhatt, 2006, combined by author).

Two attributes are important and thus described in more detail in the next two subsections: energy supply and coupling.

2.2.1 Energy Supply

There are different types of RFID tags. Certain experts and users distinguish between passive, semi-passive/-active, and active tags (Hawrylak, Mickle & Cain, 2008; EPCglobal Inc.; RFID Journal). Other experts and users differentiate between passive tags, active tags, and

⁴ The ultra high frequency 868 MHz is allocated in Europe and 915 MHz in the USA.

short-range devices (Finkenzeller, 2006; Kern, 2006; Bensky, 2004). It is undisputed that passive tags do not have an independent internal energy source. These tags use the waves of the RFID reader to generate energy in the tag. The debate identified herein evolves around the non-passive tags: active tags, semi-passive/-active tags, and short-range devices. The question is which power source a non-passive tag uses to transmit the data stored in it back to the RFID reader:

- If the energy for transmission is transduced from the RFID reader and the internal tag power source (e.g., a battery) is only used to store (secure) the data on the microchip of the RFID tag, then Hawrylak, Mickle & Cain (2008), EPCglobal Inc., and RFID Journal call such a tag a *semi-passive* tag.
- If a tag has an onboard powered transmitter but no receiver, then Hawrylak, Mickle & Cain (2008) call it a *semi-active* tag.
- If the internal RFID tag energy source is used not only for storing (securing) the data in the microchip of the tag but also for the transmission of such data to the reader, then Hawrylak, Mickle & Cain (2008), EPCglobal Inc., and (RFID Journal) talk of *active* tags.

Contrary to this view, Finkenzeller (2006), Kern (2006), and Bensky (2004) stipulate that active tags use their own power source *only* to supply the microchip on the tag with energy but not to transmit the data from the transponder to the reader. The advantage of an own power supply in active tags is that the entire energy from the reader can be used for data transmission because the microchip is already supplied with energy by a separate power source (e.g., the tag-internal battery). This dual energy supply has positive effects on the read range because no energy from the reader is lost for powering the microchip (Finkenzeller, 2006; Kern, 2006). Active RFID tags in this sense do not have the capability of emitting their own high-frequency signal. Tags with the capability of emitting an own frequency signal are not RFID tags but rather *short-range devices* (Finkenzeller, 2006). These devices emit their own high-frequency electro-magnetic field without influencing the field of the reader. This differentiation is confirmed:

“A quite different aspect of the data source is the case for RFIDs. Here the data are not available in the transmitter but are added to the RF signal in an intermediate receptor, called a transducer. [...] This transducer may be passive or active, but in any case the originally transmitted radio frequency is modified by the transducer and detected by a receiver that deciphers the data added [...] A basic difference between RFID and [transmitter - receiver] is that RFID devices are not communication devices per se but involve interrogated transponders.” (pp. 6-7 & 116) (Bensky, 2004)

Table 5 summarises the different positions of the authors cited with regard to RFID tag power supply and functionality.

Authors \ Functionality ⁵	Finkenzeller (2006)	Kern (2006)	Bensky (2004)	Glover & Bhatt (2006)	Hawrylak, Mickle & Cain (2008)	EPCglobal Inc.	RFID Journal
No power supply on tag	Passive tag						
Power supply on tag to power microchip, but not for communication	Active tag	Active tag	Active tag	Semi-passive tag	Semi-passive tag	Semi-passive tag	Semi-passive tag
Battery to power microchip and for communication	Short-range device	Short-range device	Short-range device	Active tag	Active tag	Active tag	Active tag

Table 5: Summary of power supply and tag functionality.

Glover & Bhatt (2006) acknowledge the differentiation of power source for passive and active tags. Traditionally, active tags use the internal energy source to power the microchip and the reader to power communication. However, these authors, similar to Hawrylak, Mickle & Cain (2008), opt to use the term semi-passive for tags that use the

⁵ The functionality by semi-active tags is omitted.

internal power supply only to feed the microchip (or other devices) but not for communication. Such semi-passive tags use, for example, backscatter to communicate (see next section).

A survey conducted worldwide by the author among industrial RFID experts in July 2008 has shown that for 22% of the respondents an active RFID tag does *not* use its own power source to power the transmission of data. This corresponds to the definition by Finkenzeller (2006), Kern (2006), and Bensky (2004) of an active RFID tag. 78% of the respondents define an active RFID tag as being able to transmit its signal indiscriminately without transducing the power of the reader. This corresponds to the definitions of an active RFID tag by Hawrylak, Mickle & Cain (2008), EPCglobal Inc., and RFID Journal.

This thesis follows the narrower classification of Finkenzeller (2006), Kern (2006), and Bensky (2004). As will be argued in Section 6.2 and the Marketing Article, promoting short-range devices as active RFID tags might backfire on the RFID industry.

2.2.2 Coupling

Coupling is the mechanism by which a transponder circuit and a reader circuit influence one another for supplying the transponder with energy as well as for data transfer to the reader. There are three main coupling modes: inductive coupling, capacitive coupling, and backscatter coupling (Finkenzeller, 2006; Kern, 2006).

First, transponders of *inductive coupling systems* are mainly used only in passive tags (Finkenzeller, 2006; Kern, 2006). The reader must provide the energy required for both the data signal and operation of the microchip. The inductively coupled transponder usually comprises a microchip and an antenna coil. The reader's antenna generates an electromagnetic field. When a tag is within the interrogation zone of a reader, the tag's antenna generates voltage by electromagnetic induction that is rectified and serves as power supply for the tag. The data transfer back to the reader works by load modulation: when a resonant transponder is within the range of the electromagnetic field, it absorbs and reduces the energy of the reader's magnetic field, which can be represented as change of impedance. The switching on and off a load resistor by the transponder can also be detected by the reader.

This on-and-off change allows the interpretation of a (binary) signal and subsequently a data transfer.

Second, capacitive coupling systems use plate capacitors for the transfer of power from the reader to the transponder. The reader comprises an electrode (e.g., metal plate). By a very precise placement of the transponder on the reader a functional setup similar to a transformer is generated. If a high-frequency voltage is applied to this electrically conductive area of the reader, a high-frequency field is generated. A voltage is generated between the transponder electrodes if the transponder is placed within the electrical field of the reader. This voltage supplies the transponder with power. Similar to the load modulation of inductive coupling, the read range of a reader is dampened when an electrically coupled tag is placed within the resonant circuit. This allows the modulation resistor to be switched on and off (data transfer) (Kern, 2006).

Third, long-distance backscatter systems are often used in active or semi-passive tags, i.e., they are supported by an additional energy source for the microchip within the transponder. The source energy for the transponder emitted by the reader is partly reflected by the transponder and sent back to the reader. Backscatter coupling is based on the principle of the radar technique (see Section 1.1), in which electromagnetic waves are reflected by objects with dimensions larger than half the length of a wave. In this coupling mode, a load resistor is switched on and off in time to transmit data from the transponder to the reader, thereby modulating the amplitude of the reflected power (modulated backscatter) (Finkenzeller, 2006; Kern, 2006).

2.3 RFID Standards

In the past decades, the ever growing amount and complexity of technological innovations have resulted in an increase of standards to be followed by the industry (Schmitt, 2008). A standard is an agreed-upon way of doing something:

“[A] standard denotes a uniform set of measures, agreements, conditions, or specifications between parties; the latter may be buyer-seller, manufacturer-user, government-industry or government-governed,

retailer-manufacturer-consumer, or any other parties. Commerce and trade are built on a foundation of rational standards.” (p. 1) (Spivak & Brenner, 2001).

There are various differentiators for standards, for instance, territorial scope (national international), ownership scope (proprietary or public), or functional scope (quality, security, compatibility, and interoperability) (Blind, 2004; Schmitt, 2008). In the field of RFID two main standards can be identified: RFID standards by the International Organisation for Standardization (ISO) and RFID standards by EPCglobal Inc., the industry-driven standards for the electronic product code (EPC). Whereas ISO standards are inter-sectoral in that they primarily cover the air interface, the EPC standards are more industry specific in that they focus stronger on the requirements of, and by, a specific sector. ISO standards are application independent and cover the scope of technology, data, device conformance and performance, and applications. The EPC standard includes an unambiguous numbering scheme that allow the identification of goods and ensures a globally interoperable RFID deployment (Schmitt, 2008).

The EPC tags are defined in four classes (EPCglobal Inc., 2009):

- Class 1: passive backscatter identity tags;
- Class 2: higher functionality passive tags;
- Class 3: battery-assisted passive tags; and
- Class 4: active tags.

The Gen-2 (generation 2) protocol is often mentioned in conjunction with RFID, currently class 1 tags. It provides a standardised method of communication at 860 MHz – 960 MHz between the reader and the tag to allow interoperability between readers and tags developed by different suppliers. It provides a global standard communication protocol. The Gen-2 protocol has been approved by the ISO standard (ISO 18000-6C) (Hawrylak, Mickle & Cain, 2008).

A selection of the current ISO RFID standards is provided in the following:

Designation	Content
Animal identification	
ISO / IEC 11784	Radio-frequency identification of animals – code structure
ISO / IEC 11785	Radio-frequency identification of animals – technical concept
ISO / IEC 14223	Radio-frequency identification of animals – advanced transponders
Contactless chip cards	
ISO / IEC 10536	Identification cards – Contactless integrated circuit(s) cards (close coupling: < 1 cm)
ISO / IEC 14443	Identification cards – Proximity integrated circuit(s) cards (proximity coupling: < 10 cm)
ISO / IEC 15693	Identification cards – contactless integrated circuit(s) cards – Vicinity Cards (vicinity coupling: < 1 m)
Goods and merchandise	
ISO / IEC 15961:2004	Application interface
ISO / IEC 15962:2004	Transponder interface
ISO / IEC 15963:2004	Identification of transponder
ISO / IEC 17358	Supply chain application for RFID – Application requirements
ISO / IEC 17363	Supply chain application for RFID – Freight containers
ISO / IEC 17364	Supply chain application for RFID – Transport units
ISO / IEC 17365	Supply chain application for RFID – Returnable transport items
ISO / IEC 17366	Supply chain application for RFID – Product packaging
ISO / IEC 17367	Supply chain application for RFID – Product tagging
ISO / IEC 18000-1:2004	Generic Parameter for Air Interface Communication for Globally Accepted Frequencies
ISO / IEC 18000-2:2004	< 135 kHz
ISO / IEC 18000-3:2004	13.45 MHz
ISO / IEC 18000-4:2004	2.45 GHz
ISO / IEC 18000-6:2004v	868 / 915 MHz (with amendment)
ISO / IEC 18000-7:2004	433 MHz

Table 6: Selected ISO standards (adapted from Finkenzyler (2009); Schmitt (2008)).

The current EPC standard overview is provided in Figure 6:

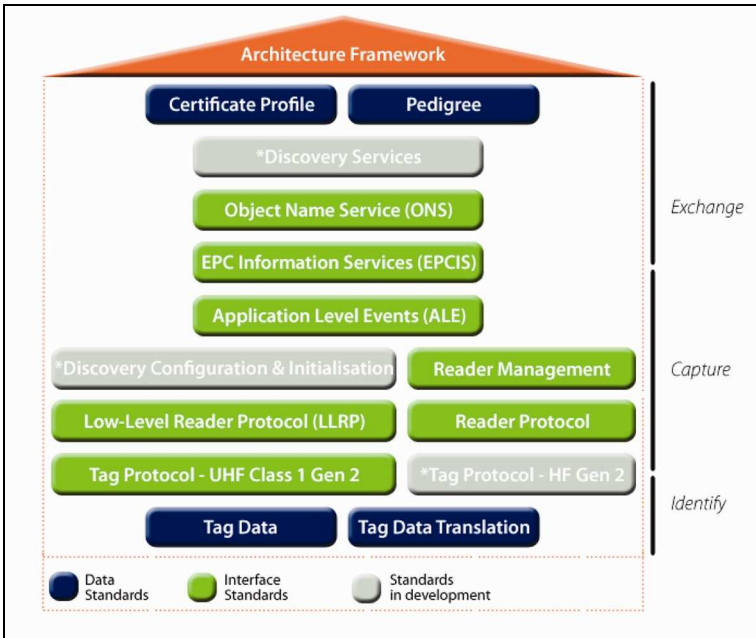

Figure 6: Overview of EPCglobal Standards (EPCglobal Inc., 2009).

2.4 RFID Equipment

Table 7 shows RFID equipment examples of passive and active RFID tags, different readers as well as mobile and fixed antennas. The passive tag examples are sticker tags (A and B). These tags contain a microchip with a coil and are self-adhesive. The IBM labelled RFID tag is a combined RFID/barcode sticker tag (B) that allows wireless communication but also line-of-sight barcode scanning. The two so-called active tag examples are approximately 3 cm to 7 cm big (C and D). To the extent that these tags beacon indiscriminately (indicated by a small flashing light), they are classified in this thesis as short-range devices (see in detail the Marketing Article). The mobile reader example devices show a handheld reader (F) as well as a mobile antenna with the power supply (E). Finally, a fixed installation reader is depicted (G). This type of reader is most probably familiar to the

majority of people from shopping malls and centres (at entrance and cashier).







<p>Passive tags</p> <p>A: microchip with coil of a transponder on a sticker (approx. 7cm)</p> <p>B: Combined barcode & RFID passive tag sticker (approx. 7 cm)</p>	<p>A</p> 	<p>B 1 (front)</p> 	<p>B 2 (back)</p> 
<p>Active tags (short-range devices, see Section 2.2.1)</p> <p>C: square tag (approx. 3 cm)</p> <p>D: rectangular tag (approx. 7 cm)</p>	<p>C</p> 	<p>D</p> 	
<p>Reader</p> <p>E: Mobile antenna with power supply in suitcase (approx. 35 cm)</p> <p>F: Handheld reader in docking station (approx. 20 cm)</p>	<p>E</p> 		<p>F</p> 
<p>Reader</p> <p>G: Fixed installation of antennas (approx. 150 cm)</p>	<p>G</p> 		

Table 7: Different RFID tags, antennas, and readers (Photos by author; courtesy of IBM Research GmbH, Switzerland).

2.5 RFID Applications

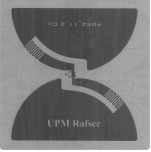
Having introduced the basics of RFID technology, this sub-section provides a selected overview of RFID applications. There are many industries that adopt and diffuse RFID technology. The following selection by the author provides examples of ten different industries (in alphabetical order): agriculture, consumer goods, healthcare, household, leisure, logistics, public sector, private sector, service, and transportation. One case of an RFID pilot or implementation is offered here as example per industry. The following examples were selected to provide the reader with a wide and interesting variety of RFID pilot projects and applications.

2.5.1 Agriculture

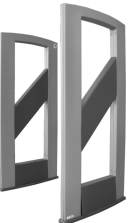
Since 2005, each head of cattle in Canada must be tagged with a transponder on the ear. It enables a seamless *tracking* of each head of cattle that leaves its herd of origin. The RFID tag stores encrypted producer information. Veterinaries and meat-processing plants that take part in the RFID program scan the RFID tag data and forward the scanned data to the Canadian Cattle Identification Agency (METRO Group, 2008). The Canadian Cattle Identification Agency has implemented national standards for RFID-tagging. All tags have a 15-digit number consisting of a lead country code followed by a 12-digit unique identification number (Canadian Cattle Identification Agency, 2008).

2.5.2 Consumer Goods

The Consorzio Latterie Virgilio in Italy is striving to become a well-established brand name for dairy products. It plans to include a certificate for guaranteed ageing and traceability of production plants for Grana Padano and Parmigiano Reggiano cheese (Consorzio Latterie Virgilio, 2008). The excellent quality of these cheeses has a high price and thus attracts counterfeiters that try to market inferior products as genuine cheeses from the region. RFID tags containing information authenticating the origin and quality as well as production date and price have been implanted in the rind of the Parmigiano Reggiano Virgilio cheese. *Fraud prevention* success of the pilot was confirmed in 2003 (METRO Group, 2008).

2.5.3 Healthcare

The Vassar Brothers Medical Center in USA improved *patient safety* and operational efficiency through RFID innovation. The solution provides a single broadband environment that supports both current and future wireless protocols for voice, data, telemetry and RFID applications. Barcoding and active RFID technology enable the hospital to reduce medication errors by 95% and to track the hospital's inventory (IBM Corporation, 2007). It is anticipated that barcoded medication distribution in future applications will be replaced by RFID-based solutions. RFID tags attached to a patient's medication tray, for instance, will be able to set off an alarm if a doctor or nurse enters a patient's room with the wrong medication tray.

2.5.4 Household

VitaCraft in Japan sells robotic cookware. RFID tags are embedded in the handles of the pans of VitaCraft. The handles also feature an RFID reader. The RFID tag communicates with the coordinated RFID tags in the cooking plate and the recipe cards specially designed for VitaCraft's pans (Vita Craft Corporation, 2008). The handle's RFID reader scans the information stored on the recipe cards. During cooking, the pan checks the individual steps and the hot plate temperature 16 times per second. If necessary, it makes appropriate adjustments to *optimise* the cooking result (METRO Group, 2008).

2.5.5 Leisure

In 2006, the Fédération Internationale de Football Association (FIFA) personalised the tickets for the soccer world cup in Germany to ensure security in the stadiums and limit black market activities. It did so by embedding an RFID tag into each ticket. The data submitted during the ordering process was stored on the RFID tag in the ticket. Stadium marshals were able to access this information at the stadium entrance to verify *access authorisation*. In random checks, they were able to determine whether the ticket holder was actually the person registered (METRO Group, 2008).

2.5.6 Logistics

The container terminal Altenwerder at the Hamburger Hafen und Logistic Altenwerder GmbH in Germany has been equipped with RFID technology that synchronises freight *navigation*. Gantry trolleys load and discharge containers to and from vessels. These containers are lowered to or taken from driverless automated guided vehicles (AGV) that handle transportation between the gantry crane and the storage blocks (Drossel & Behn, 2008). The vehicles are equipped with an RFID reader. The asphalt paving of the port contains approximately 14'000 embedded transponders. A vehicle management program computes and guides the driverless AGV via the most efficient route to their destination (METRO Group, 2008).

2.5.7 Public

As per January 2009 more 60 states worldwide have issued passports containing electronically stored data according to the international standards ("ePass") (Schweizerische Eidgenossenschaft, 2009a). On December 13, 2004, the Council of the European Union adopted a regulation on standards for security features and biometrics in passports and travel documents issued by the EU member states (Council of the European Union, 2004). In 2005, the Federal Government of Germany introduced a passport with such machine-readable biometric data. This electronic passport ("ePass") contains an RFID tag that stores an encrypted digital photograph along with the holder's personal data. It also stores two fingerprints. The biometric data stored in the passport should increase identification *security* (Bundesministerium des Innern, 2008). In Switzerland (an associated member state of the Schengen Agreement), the people accepted in a federal voting of May 17, 2009 the introduction of the electronic passport. The Swiss Federal Act stipulates that one photo and two finger prints will be stored on the RFID that is integrated into the Swiss passport (fon, 2009). In addition, however, the biometric data will also be stored in a central database. The latter has raised concern among political parties with regard to mandatory registration of biometric data and privacy protection vis-à-vis the Swiss state (Schweizerische Eidgenossenschaft, 2009b).

2.5.8 Private

The author's two cats carry an RFID tag below their left ear. On the one hand, this RFID tag administered by Animal Identity Service AG (2008) provides an unambiguous identification of pets (lost/found, injury, death). On the other hand, the RFID tag can be used for access identification. Special cat doors equipped with RFID readers can be programmed to unlock only when a cat with a certain identification number (in this case the author's cats) approach. An RFID tag the size of a rice corn is used to mark the author's cats. It is injected by a veterinarian into the flesh beneath the left ear. In Figure 7, the RFID tag of one cat is read on a mobile RFID reader. In Figure 8, the other cat enters through the cat door.

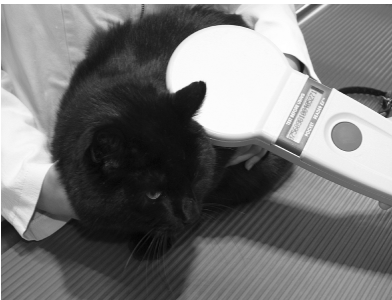

Figure 7: Cat with RFID reader showing identification number (Photo by author).



Figure 8: Cat entering through cat door that can be RFID-enabled (Photo by author).

2.5.9 Service

American Express has introduced “expresspay”, a payment technology that allows a credit card holder to make purchases more comfortably without having to swipe the credit card through a reader. The card can be held within 10 cm of an RFID cashier reader for a transaction to be processed. “Expresspay” transactions are processed through the same secure payment network as other financial transactions by the card issuer. In addition, a unique cryptogram is generated to prevent fraudulent transactions (American Express, 2008).

2.5.10 Transport

Tyre manufacturer Michelin in USA sells tyres that allow extended tyre maintenance. Tyres are equipped with an RFID tag and a pressure / temperature sensor. The RFID tag stores information about production date, size, and required filling pressure so as to allow the tag to automatically feed back information collected by the sensors on insufficient air pressure and tyre temperature to the vehicle's driver (Michelin, 2008). A service center mechanic can scan the information with an RFID reader and make a diagnosis. The RFID tag also enables precise product recalls (METRO Group, 2008).

2.5.11 Summary RFID Applications

The following Table 8 summarises the RFID applications:

Industry	Company	Application scope	Placement of RFID	Country
Agriculture	Canadian Cattle Identification Agency (CCIA)	Traceability & disease prevention	Ear of cattle	Canada
Consumer Goods	Consorzio Latterie Virgilio	Protection from counterfeiting	Rind of cheese	Italy
Healthcare	Vassar Brothers Medical Center	Patient security	Hospital equipment, medication box	USA
Household	Vita Craft Corporation	Product optimisation	Handle of pan, cooktop and cookbook	USA, Japan
Leisure	FIFA	Access authorisation	Stadium entry ticket	Switzerland, Germany
Logistics	Hamburger Hafen und Logistic	Navigation & process optimisation	Pavement at the port	Germany

[continued on next page]

Industry	Company	Application scope	Placement of RFID	Country
Public	Federal Republic of Germany	Identification & public security	Passport	Germany, Switzerland
Private	Author's home	Pet identification and access control	Below left ear	Switzerland
Service	American Express	Comfort	Credit card	USA
Transport	Michelin	Safety & transparency	Tyres	USA

Table 8: Summary of examples of RFID pilots and implementations (in alphabetical order).

2.6 Chapter Summary

Chapter 2 supplies the reader with the necessary RFID technology know-how (technological features, standards, equipment, and applications) to understand this thesis. It argues differences in the concepts of ubiquitous computing, pervasive computing, and ambient intelligence, in favour of the concept of pervasive computing. The energy supply and coupling techniques with which RFID systems operate are explained. Several different RFID standards by ISO and EPCglobal are outlined. RFID tags (active and passive) as well as different readers (fixed and mobile) are presented. Finally, various RFID application are exemplified for ten industry sectors.

Chapter 3

Innovation and Regulation

Chapter 3 sets the definitional framework for this thesis. First, an attempt is made to define innovation. Ten adoption and diffusion theories are outlined (Section 3.1). Second, an attempt is made to define regulation. Several regulation theories and applications are presented (Section 3.2).

3.1 Innovation

Innovation is studied in many disciplines and has been defined from many different perspectives (Damanpour & Wischnevsky, 2006). Googling the Internet will (currently⁶) return as many as 112 million general entries sub verbo *innovation* as well as approximately 1.5 million academic entries in Google Scholar. At times, it even seems as if the word *innovation* (similar to the word *design*) is used by society in an almost inflationary and buzzword-style way, albeit with positive connotation (Gerpott, 2008). But then, innovation is arguably as old as mankind itself (Fagerberg, 2005).

Unsurprisingly there are various definitions of, and approaches to, innovation. For instance, innovation definitions are listed according to Mohr's (1969) two categories (Lee & Treacy, 1988): (a) innovation is *invention* as creative act of development, i.e., the invention of something new (Barnett, 1953; Souder, 1977; Damanpour & Evan, 1984); and (b) innovation is the successful *introduction* of invention into an applied situation of means or ends that are new to that situation (Gerwin, 1981; Becker & Whisler, 1967; Carroll, 1967). Similarly, invention has been defined as the first occurrence of an idea, whereas innovation is the first attempt to carry it out into practice (Fagerberg, 2005). Innovation research differentiates between process, product, and organisational innovation. Innovation can be defined as the realisation of the technically feasible into a market-driven and marketable solution (Rodi, 2008). A figurative definition

⁶ May 24, 2009.

suggests that “[i]nnovation is the sap that flows in the technological tree [...]” (p. 274) (Uddin, 2006). Rogers (2003) describes innovation as “an idea, practice, or object perceived as new by an individual or other unit of adoption” (p. 12).

Technological innovation has been defined as new production input, machine, process, and technique adopted by firms (Malecki, 1977). In addition, it is noted that most of the new ideas that have been analysed are *technological* innovations. Technology usually has two components: hardware (physical object) and software (information base for the hardware). The words innovation and technology are often used as synonyms (Rogers, 2003).

Two attributes describe innovation: adoption and diffusion. Diffusion theory deals with the adoption and diffusion of innovations. The term adoption refers to the acceptance of a specific innovation by a potential user. The process that leads to the acceptance of a specific innovation is the process of adoption. In case of a rejection there is consequently no adoption. Diffusion follows adoption. In contrast to the adoption process, the diffusion process of an innovation relates to the cumulated adoptions over time (Felten, 2001). Diffusion is the process of communication of an innovation by the members of a social system (Schmitt, 2008). Diffusion is the aggregate result of individual adoption processes (Felten, 2001; Schmitt, 2008).

In the past twenty years a lot of theoretical and empirical work has accumulated on the adoption and diffusion of IT-based innovations (Jeyaraj, Rottman, & Lacity, 2006). This sub-section outlines ten innovation adoption and diffusion theories (Venkatesh, Morris, Davis, & Davis, 2003). These ten theories include both individual and organisational adoption and diffusion studies (Jeyaraj, Rottman, & Lacity, 2006).

3.1.1 Theory of Reasoned Action (TRA)

The *theory of reasoned action* (TRA) (Fishbein & Ajzen, 1975) is a widely studied model from social psychology (Davis, Bagozzi, & Warshaw, 1989). TRA states that a person’s performance of a specified behaviour is determined by his or her behavioural intention to perform the behaviour; the behavioural intention is jointly determined by the person’s attitude and subjective norm concerning

the behaviour in question. Hence, the characteristics of TRA are threefold: behavioural intention, attitude, and subjective norm. Behavioural intention is a measure of strength of a person's intention to perform a specific behaviour; attitude is defined as a person's positive or negative feelings about performing the target behaviour; and subjective norm refers to a person's perception of whether other people think he or she should, or should not, perform the behaviour in question (Davis, Bagozzi, & Warshaw, 1989). TRA has been extended by the theory of planned behaviour.

3.1.2 Theory of Planned Behaviour (TPB)

The *theory of planned behaviour* (TPB) (Ajzen, 1991) adds perceived behavioural control to the characteristics of TRA. With TPB, attitudes toward the behaviour, subjective norms with respect to the behaviour, and perceived control over the behaviour are usually found to predict behavioural intentions with a high degree of accuracy. Whereas the importance of actual behavioural control seems self-evident in that resources and opportunities available to a person must to some extent dictate the likelihood of behavioural achievement, perception of behavioural control and its impact on intentions and actions seem to be of greater control. To such extent TPB differs from TRA in its addition of perceived behavioural control (Ajzen, 1991).

3.1.3 Model of PC Utilisation (MPCU)

The *model of PC utilization* (MPCU) (Thompson, Higgins, & Howell, 1991) uses a theory of behaviour competing with TRA. MPCU shows that social norms and three components of expected consequences, namely complexity of use, job-fit, and long-term consequences, have a strong influence on utilisation.

3.1.4 Social Cognitive Theory (SCT)

The *social cognitive theory* (SCT) (Bandura, 1986) stipulates that part of a person's knowledge acquisition can be directly related to observing others within the context of social interactions, experiences, and outside media influences. Three characteristics are relevant: environment, behaviour, and cognition. SCT also posits that learning will most likely occur if a person has a good deal of self-efficacy. Self-

efficacy refers to people's judgments or their capabilities to organize and execute courses of action required to attain designated types of performances. Self-efficacy is concerned not with the skills a person has but with judgments of what a person can do with whatever skills he or she possesses (Bandura, 1986).

SCT differentiates between a person's ability to be morally competent (i.e., having the ability to perform moral behaviour) and to be morally performing (i.e., fulfilling moral behaviour in a specific situation). The former includes a person's capability, knowledge, skills, awareness of moral rules and regulations, and cognitive ability to construct behaviours (Santrock, 2008). SCT has been used to research computer utilisation (Compeau & Higgins, 1995).

3.1.5 Technology Acceptance Model (TAM)

The *technology acceptance model* (TAM) (Davis, 1989) is another extension of the TRA. TAM is specifically tailored for modeling user acceptance of IS (Davis, Bagozzi, & Warshaw, 1989). It adapts TRA to the particular domain of technology acceptance and replaces TRA's attitudinal determinants with two variables specific to the technology acceptance context (Bagozzi, Davis, & Warshaw, 1992), but it excludes TRA's subjective norm (Davis, Bagozzi, & Warshaw, 1989). TAM defines how users accept technological innovations and introduces the characteristics ease of use and usefulness. The former is "the degree to which a person believes that using a particular system would enhance his or her job performance" (p. 320); and the latter is "the degree to which a person believes that using a particular system would be free from effort" (p. 320) (Davis, 1989). The key purpose of TAM is to provide a basis for tracing the impact of external factors on internal beliefs (Davis, Bagozzi, & Warshaw, 1989). A decade after its introduction, TAM was extended to TAM 2.

3.1.6 Extension of TAM (TAM 2)

The *extension of the technology acceptance model* (TAM 2) (Venkatesh & Davis, 2000) posits that the determinants of perceived usefulness have been relatively overlooked. Therefore, the goal of TAM 2 is to include additional key determinants of TAM's perceived usefulness and usage intention constructs. TAM 2 theorises that in a

computer usage context, the direct compliance-based effect of subjective norm on intention over and above perceived usefulness and perceived ease of use will occur in mandatory, but not voluntary, system usage settings (Venkatesh & Davis, 2000). Hence, the subjective norm exerts a significant direct effect on usage intentions over and above perceived usefulness and perceived ease of use for mandatory systems, but not voluntary ones.

3.1.7 Combination of TAM and TPB (C-TAM-TPB)

The theory of *combination of TAM and TPB* (C-TAM-TPB) (Taylor & Todd, 1995) combines the predictors of TPB, i.e., attitude, social norm, and perceived behavioural control, with the characteristics of TAM, i.e., ease of use and usefulness. Prior experience has been found to be an important determinant of behaviour. It has been suggested that knowledge gained from past behaviour will help to shape a person's intention (Fishbein & Ajzen, 1975). Hence, C-TAM-TPB can be applied to understand the behaviour of both experienced and inexperienced IT users. The latter, however, place different emphasis on the characteristics of intention and usage. Inexperienced users focus primarily on perceived usefulness, and less on other characteristics (Taylor & Todd, 1995).

3.1.8 Innovation Diffusion Theory (IDT)

The *innovation diffusion theory* (IDT) (Rogers, 2003) is a general theory on diffusion of innovation and is not IT specific; but it can and, in the past, has been used to research technological innovations. This theory is about how, why, and at what rate new ideas and innovations spread. IDT defines diffusion as process, communication and social change, regardless of whether planned or spontaneous. Diffusion is the process in which an innovation is communicated through certain channels over time among the members of a social system. Diffusion is a special type of communication in which the messages are about a new idea. And finally, diffusion is a kind of social change, defined as the process by which alteration occurs in the structure and function of a *social system* (Rogers, 2003).

The intrinsic characteristics of technological innovations that lead to either adoption or rejection are: relative advantage (improvement of

technological innovation over previous generation); compatibility (assimilation of technological innovation to known previous experience); complexity (ease of use of technological innovation); trialability (flexibility of experimenting with technological innovation); and observability (visibility of technological innovation to others) (Rogers, 2003).

It has been suggested that – as compared to other theories on adoption and diffusion of innovation – Rogers' (2003) IDT stands out in that it is the only theory that covers both domains of adoption and diffusion by individuals and by organisations. However, it is also noted that it is quite common for researchers to choose, pick, and integrate innovation characteristics from other theories (Jeyaraj, Rottman, & Lacity, 2006).

3.1.9 Perceived Characteristics of Innovations (PCI)

The theory of *perceived characteristics of innovations* (PCI) (Moore & Benbasat, 1991) is a tool that studies the initial adoption of IT by individuals in organisations. PCI focuses on the perceived characteristics of using a technological innovation: as different adopters might perceive primary characteristics in different ways, the possible behaviours of such adopters might differ. Hence, innovations diffuse because of the cumulative decisions of individuals to adopt them. It is not the potential adopters' perception of the innovation itself, but rather their perceptions of using the innovation that are key to whether the innovation diffuses (Moore & Benbasat, 1991).

Therefore PCI redefines existing characteristics of, for instance, IDT (Rogers, 2003) or TAM (Davis, 1989) to cover the perception of actually using the technological innovation, not the technological innovation itself (Moore & Benbasat, 1991).

3.1.10 Unified Theory of Acceptance and Use of Technology (UTAUT)

The *unified theory of acceptance and use of technology* (UTAUT) (Rogers, 2003) theorises that a combination of different constructs of acceptance models play a significant role as direct determinants of user acceptance and usage behaviour. This theory advances individual acceptance research by unifying the theoretical

perspectives common in the literature. Four constructs play a significant role as direct determinants of user acceptance and usage behaviour:

- (i) performance expectancy that derives from usefulness (TAM, TAM 2, C-TAM-TPB), extrinsic motivation (MM), job-fit (MPCU), relative advantage (IDT), and outcome expectations (SCT); performance expectancy is moderated by gender and age;
- (ii) effort expectancy that derives from perceived ease of use (TAM/TAM 2), complexity (MPCU), and ease of use (IDT);
- (iii) social influence that derives from subjective norm (TRA, TAM 2, TP, and C-TAM-TPB), social factors (MPCU) and image (IDT); and
- (iv) facilitating factors that derive from perceived behavioural control (TPB, C-TAM-TPB), facilitating conditions (MPCU), and compatibility (IDT).

3.1.11 Summary of Adoption and Diffusion Theories

The following Table 9 summarises in chronological order (column 1) the theories of adoption and diffusion of innovation (generic and with regard to technological innovations); lists the characteristics of each theory, which might not be explicitly specified in the brief overview in the preceding sub-sections (column 2); and finally defines each of these characteristics (column 3). Definitions of characteristics that are replicated among the theories are not repeated but cross-referenced.

Theory / Model and Author (by year)	Characteristics	Definitions
Theory of reasoned action (TRA) (Fishbein & Ajzen, 1975)	Attitude towards behaviour	“[A]n individual’s positive or negative feelings (evaluative effect) about performing the target behavior.” (p. 216)
	Subjective norm	“[A] person’s perception that most people who are important to him [or her] think he [or she] should or should not perform the behavior in question.” (p. 302)

[continued on next four pages]

Theory / Model and Author (by year)	Characteristics	Definitions
<p>Innovation diffusion theory (IDT) (Rogers, 2003 (1983, 1995))</p> <p>Definitions of characteristics by (Tornatzky & Klein, 1982)</p>	Compatibility	“[T]he degree to which an innovation is perceived as being consistent with the existing values, past experiences, and needs of the receivers.” (p. 33)
	Relative advantage	“[T]he degree to which an innovation is perceived as being better than the idea it supersedes.” (p. 34)
	Complexity (ease of use)	“[T]he degree to which an innovation is perceived as relatively difficult to understand and use.” (p. 35)
	Cost	---
	Communicability	“[T]he degree to which aspects of an innovation may be conveyed to others.” (p. 36)
	Divisibility	“[The] extent to which an innovation can be tried on a small scale prior to adoption.” (p. 37)
	Profitability	“[The] level of profit to be gained from adoption of the innovation.” (p. 37)
	Social approval	“[The] status gained in one’s reference group, ‘a nonfinancial aspect of reward’ [...], as a function of adopting a particular innovation.” (p. 37)
	Triability	“[T]he degree to which an innovation may be experimented with on a limited basis.” (p. 38)
	Observability	“[T]he degree to which the results of an innovation are visible to others.” (p. 38)
<p>Social cognitive theory (SCT) (Bandura, 1986)</p> <p>Definitions of characteristics by (Venkatesh, Morris, Davis, & Davis, 2003)</p>	Self-efficacy	“Judgment of one’s ability to use a technology (e.g., computer) to accomplish a particular job or task.” (p. 432)
	Performance outcome expectations	“The performance-related consequences of the behavior. Specifically, performance expectations deal with job-related outcomes.” (p. 432; emphasis omitted)
	Personal outcome expectations	“The personal consequences of the behavior. Specifically, personal expectations deal with the individual esteem and sense of accomplishment.” (p. 432)

Theory / Model and Author (by year)	Characteristics	Definitions
	Affect	"An individual's linking for a particular behavior (e.g., computer)." (p. 432)
	Anxiety	"Evoking anxious or emotional reactions when it comes to performing a behavior (e.g., using a computer)." (p. 432)
Technology acceptance model (TAM) (F. D. Davis, 1989)	Ease of use	"[T]he degree to which a person believes that using a particular system would be free of effort." (p. 320)
	Usefulness	"[T]he degree to which a person believes that using a particular system would enhance his or her job performance." (p. 320)
Perceived characteristics of innovations (PCI) (Moore & Benbasat, 1991)	Relative advantage	See IDT, above.
	Compatibility	See IDT, above.
	Complexity (ease of use)	See IDT, above.
	Result demonstrability	---
	Image	"[T]he degree to which use of an innovation is perceived to enhance one's image or status in one's social system." (p. 195)
	Visibility	---
	Triability	See IDT, above.
	Voluntariness	"[T]he degree to which use of the innovation is perceived as being voluntary, or of free will." (p. 195)
Theory of planned behaviour (TPB) (Ajzen, 1991)	Attitude towards behaviour	See TRA, above.
	Subjective norm	See TRA, above.
	Perceived behavioural control	"[T]he perceived ease or difficulty of performing the behavior." (p. 188)
Model of PC utilisation (MPCU) (Thompson, Higgins, & Howell, 1991)	Job-fit	"[T]he extent to which an individual believes that using [a technology] can enhance the performance of his or her job." (p. 129)
	Complexity	See IDT, above.
	Long-term consequences	"Outcomes that have a pay-off in the future." (p. 129)

Theory / Model and Author (by year)	Characteristics	Definitions
	Affect towards use	“[The] feeling of joy, elation, or pleasure, or depression, disgust, displeasure, or hate associated by an individual with a particular act.” (p. 127)
	Social factors	“[T]he individual’s internalization of the reference group’s subjective culture, and specific interpersonal agreements that the individual has made with others, in specific social situations.” (p. 126)
	Facilitating conditions	“Objective factors in the environment that observers agree make an act easy to accomplish.” (p. 430) (Venkatesh et al., 2003)
Motivational Model (MM) (F. D. Davis, Bagozzi, & Warshaw, 1992)	Extrinsic motivation	“[The perception to want to perform an activity] because it is perceived to be instrumental in achieving valued outcomes that are distinct from the activity itself.” (p. 1112)
	Intrinsic motivation	“[The perception to want to perform an activity] for no apparent reinforcement other than the process of performing the activity per se.” (p. 1112)
Combined TAM and TPB (C-TAM-TPB) (Taylor & Todd, 1995)	Attitude towards behaviour	See TRA, above.
	Subjective norm	See TRA, above.
	Perceived behavioural control	See TPB, above.
	Perceived usefulness	See TAM, above.
Technology acceptance model 2 (TAM 2) (Venkatesh & Davis, 2000)	Perceived ease of use	See TAM, above.
	Perceived usefulness	See TAM, above.
	Subjective norm	See TRA, above.
Unified theory of acceptance and use of technology (UTAUT) (Venkatesh et al., 2003)	Performance expectancy	“[T]he degree to which an individual believes that using the system will help him or her attain gains in job performance.” (p. 447)
	Effort expectancy	“[T]he degree of ease associated with the use of the system.” (p. 450)

Theory / Model and Author (by year)	Characteristics	Definitions
	Social influence	“[T]he degree to which an individual perceives that important others believe he or she should use the new system.” (p. 451)
	Facilitating conditions	“[T]he degree to which an individual believes that an organizational and technical infrastructure exists to support use of the system.” (p. 453)

Table 9: Overview of selected theoretical and empirical work on the adoption and diffusion of technological innovation, listed in chronological order (Jeyaraj et al., 2006, adapted and corrected; Venkatesh et al., 2003, adapted).

Eliminating duplicate characteristics in Table 9 reduces the list to the following characteristics used in the ten adoption and diffusion theories / models: affect towards use, anxiety, attitude towards behaviour, communicability, compatibility, complexity (ease of use), cost, divisibility, effort expectancy, extrinsic motivation, facilitating conditions, image, intrinsic motivation, job-fit, long-term consequences, observability, perceived behavioural control, perceived ease of use, perceived usefulness, performance expectancy, performance outcome expectations, personal outcome expectations, profitability, relative advantage, result demonstrability, self-efficacy, social approval, social factors, social influence, subjective norm, trialability, usefulness, visibility, and voluntariness.

3.2 Regulation

Regulation is a slippery concept (Scott, 2004). It is unclear who counts as regulator and what counts as regulation. It is also unclear what the relationship between law and regulation is: Is law an intersection of regulation or is regulation rather an intersection of law (Bronwen & Yeung, 2007)?

“Regulation is a phenomenon that is notoriously difficult to define with clarity and precision, as its meaning and the scope of its inquiry are unsettled and contested. [...] At their narrowest, definitions of regulation tend to centre on deliberate attempts by the state to influence socially valuable behaviour

which may have adverse side-effects by establishing, monitoring and enforcing legal rules. At its broadest, regulation is seen as encompassing all forms of social control, whether intentional or not, and whether imposed by the state or other social institutions.” (pp. 3-4) (Bronwen & Yeung, 2007)

A common international definition of regulation does not exist. An attempt to define regulation is to understand it to be the intentional, goal-directed, problem-solving attempt at ordering by both state and other non-state actors “to alter the behaviour of the others according to identified purposes with the intention of producing a broadly identified outcome or outcomes which may involve mechanisms of standard-setting, information-gathering and behaviour-modification” (p. 170) (Black, 2002).

Regulation is, however, always in a reciprocal effect with its antonym deregulation. In lack of an overall definition, the following terms are often used synonymously with regulation, and deregulation respectively, depending on whether the regulation or deregulation instrument is meant as such, or whether the affected domain of regulation or deregulation is addressed: state control, governance, regimentation, market regulation, re-regulation, over regulation, legal inflation for *regulation*; or internationalisation, globalisation, revitalisation, market-based regeneration, decentralisation, private regulation, liberalisation, self-regulation, privatisation for *deregulation* (Klaus, 2007).

Regulation (and thus also deregulation) can, for instance, be seen from an economic, a socio-political, and a legal viewpoint:

The *economic* viewpoint of regulation refers to state intervention in market processes to correct market failures (Gerpott, 2008). On the one hand, the focus can be on the *function* of regulation (i.e., state / governmental intervention that either constrains the economic market mechanisms or fosters them by adoption of market tasks); on the regulating *subject* (i.e., any intervention by the state); or on the *competitive parameters* (i.e., aspects of production, qualitative attributes, and price). On the other hand, economic deregulation is the return of economic sectors that have been deprived of a competitive state to a system of competition (Klaus, 2007).

The *socio-political* viewpoint of regulation refers to any kind of state influence on societal processes, not just economic ones. Hence, it can, but must not necessarily, include economic regulation. It is also known as social regulation (Klaus, 2007). Scott (2004) refers to the socio-political viewpoint as regulation in a wide sense. On the one hand, regulation in a wide sense can be identified as forms of social control, whether part of an intended system or not. It comprises not only governmental activities but also social norms and the standard setting, monitoring, and behaviour modification functions of markets. For the avoidance of doubt, in this thesis regulation by standards is referred to as regulation by law in the wide sense (see Section 4.3). On the other hand, socio-political deregulation is often understood as antonym to the economic meaning of regulation (Klaus, 2007).

The *legal* viewpoint of regulation refers to the legislative procedure of law making. Regulation in this sense encompasses sovereign laws and ordinances but also all private, hence non-sovereign, rules and regulations (Klaus, 2007). Scott (2004) refers to the legal viewpoint as regulation in a narrow sense. On the one hand, regulation in a narrow sense is viewed as a distinctive policy instrument that operates through sustained oversight by reference to rules. It comprises regulation agencies that oversee compliance with a prescribed set of rules. As understood in this thesis, this is *regulation by law*, which for the purpose of this thesis has been divided into regulation by law in the narrow sense and regulation by law in the wide sense (see Table 11). On the other hand, legal deregulation can be not only qualitative in that it refers to reduction of state intervention but also quantitative in that it strives to reduce the number of the laws or statutes (Klaus, 2007).

It has been suggested that regulation is an essentially political process. Sustaining an effective regime requires changing circumstances and involving new regulatees as they arise. It may also involve negotiating with new interest groups (Clarke, 2000). The view that regulation is *not* seen as an activity only performed by state actors, excluding other regimes, such as the market players, is shared herein. Two questions are important when referring to regulation: *why* does regulation emerge and *how* shall one regulate (Bronwen & Yeung, 2007). These two questions are addressed in the following.

3.2.1 Reasons for Regulation

Regulation by law and regulation by social norms, i.e., legal rules and social control, draw upon the disciplines of politics, economics and sociology (Bronwen & Yeung, 2007). The division of theories of such regulation is threefold: (i) public interest theory, (ii) private interest theory, and (iii) institutionalist interest theory. These three theories shall guide the discussion in the following.

First, the *public interest theory of regulation* pursues collective goals with the aim of promoting welfare. Law is seen as a sub-branch of politics with the means of achieving social ends (Prosser, 1986). These ends are not set arbitrarily by authorities. It is argued in favour of a dialogue between the parties involved (Prosser, 1986). This means that there must be participation of different interest groups, and there must be accountability for the decisions taken. It is also argued that market failure is not the only justification for regulation (Prosser, 2006) – regulation here understood by the author as regulation by law. Otherwise such regulation would always be second best to the market allocation of goods and services, and other justifications would essentially be arbitrary. Similarly to Bronwen & Yeung (2007), Prosser (2006) suggests three different rationales for regulation: economic principles, individual rights, and social solidarity. Contrary to Prosser (2006), regulation by law for Ogus (2004) is justified because the regulation regime can do what the market cannot – such regulation remedies market failure, for example monopolies, the supply of certain public goods (e.g., security), and other externalities (e.g., polluter-pay principle). Sunstein (1990) also argues for market failure as justification for regulation by law but includes regulation by law of non-economic goals (referred to by Bronwen & Yeung (2007) as virtue), such as public-interest redistribution (e.g., contribution to environmental protection), embodying collective desires (e.g., diverse broadcasting), elimination of social subordination (e.g., anti-discrimination), development of certain preferences (e.g., addictive substances), protection of future generations and protection of endangered species.

Second, the *private interest theory of regulation*, which gained prominence in conjunction with the political ideologies of deregulation (see Section 3.2), assumes that regulation (here also understood by the author as regulation by law) emerges from the self-interest of

individuals or groups. The view of private interest theory advocates that the connection between regulation by law and public interest is merely a coincidence. Public interests are often underpinned by the implicit optimism about the capacity of regulation by law (Bronwen & Yeung, 2007). The private interest theory includes a political and an economic viewpoint. From a political viewpoint, individual interest groups compete with one another to obtain favourable regulation by law. They do so by imposing their views on regulation agencies and legislators by means of votes and other political resources. This might rather seem to qualify as public interest theory. However, the difference is that in this (private) case the political arena is shaped by groups with unequal resources and no authority to intervene as referee (Bronwen & Yeung, 2007). From an economic viewpoint, the individual interest groups also seek favourable regulation by law, but rather in direct economic form, such as direct subsidies, tariff controls, or price controls (Croley, 1998).

Third, whereas public interest theory and private interest theory seem to be mirror images of each other, in the *institutionalist theory of regulation* the relationship between different rule-based spheres, such as formal organisations or embedded norms, plays an important role (Bronwen & Yeung, 2007). The public-private sphere is blurred, and it is argued that in economic regulation of markets no clear dividing line can be drawn between private interest groups and public authority. This is referred to as the concept of regulatory space (Hancher & Moran, 1989). In this space, the actions and intentions of actors of regulation are examined in a larger system and by institutional dynamics. This not only includes participants that occupy such regulatory space but also analyses the characteristics of the *excluded* actors (Hancher & Moran, 1989). Empowering public interest groups (i.e., tripartism) can solve the problem of corruption between the regulator of law and the private interest group (Ayres & Braithwaite, 1992). The public interest group shall receive the necessary information, participate in the negotiations between such a regulator and the private interest group, and receive prosecution power under the statute. Finally, system theory alludes to a self-referential (i.e., closed) system (Teubner, 1986). The area regulated by law perpetuates itself and reproduces elements with the same properties. In general, it is only comprehensible to participants of the (same)

closed system. Self-referential systems are like black boxes: they are mutually inaccessible to each other (Teubner, 1986). The input and output are known, but the conversion within the blackbox remains fuzzy. So influence can be taken not within the system itself but rather *between* several systems. Hence, influence can be taken, for example, between technological innovation and regulation by law.

3.2.2 Means of Regulation

Turning from the reasons of regulation to the regulation instruments and techniques, it is noted that so far no classification system has emerged (Bronwen & Yeung, 2007). Pluralism of instruments and techniques is valued as strength rather than weakness because it allows a critical comparison between different instruments and techniques. The Internet is an application “which suggests that control mechanisms must exhibit at least as much variety as the object that is sought to be controlled” (p. 484) Scott (2004), referring to Beer (1966). So a mix of modalities in regulation (i.e., not only regulation by law) seems justified. And indeed, the views of Scott (2004), Bronwen & Yeung (2007), and Lessig (1999) concur in general. Whereas Lessig (1999) sees behaviour regulated in four kinds of ways: by law, norms, market, and architecture; Scott (2004) refers to hierarchy, community, competition and design; and Bronwen & Yeung (2007) see a possible classification by the modality through which behaviour is sought to be controlled in regulation, namely, command, competition, consensus, communication, and code.

The four modalities of law, social norms, market and architecture (Lessig, 1999) should regulate together and the net regulation is the sum of all four regulation tools. Law orders people to behave in certain ways by threatening with punishment. Social norms regulate similarly to law, although, unlike law, punishment is not enforced by a centralised authority but rather by an entire community. Regulation by market is often price-driven. Finally, architecture also regulates in the form of shaping one's behaviour. The Internet, for example, is not just free; parts of it are regulated. The architecture of the Internet provides restraints (Lessig, 2002): at the bottom there is a physical layer that is controlled, the logical layer in the middle is free, and the content layer at the top can be either free or controlled.

The view and approach of Lessig (1999) that there are four pure modalities of regulation are supported by Scott (2004), yet with a reclassification to hierarchy, community, competition, and design. Scott (2004) analyses the regulatory system using a cybernetics approach (see Section 4.2.3). This approach reveals three components of a(n ICT) regulatory system: (i) some goal or rule to which the systems refers, (ii) some mechanisms for monitoring performance of the systems as compared to the goal or rule, and (iii) some mechanism for re-aligning the system when it deviates from the goal or rule. Each of the four modalities has functional depth in these three components.

The five “Cs” of Bronwen & Yeung (2007) are understood as follows: *Command* includes legal rules prohibiting specified conduct, underpinned by coercive sanctions in case of violation of such rules. *Competition* aims to enrol the competitive force of markets to elicit behavioural change by tools, such as charges, taxes and subsidies. *Consensus* spans a broad spectrum of regulation arrangements; in general, it primarily rests on the consent of the (public and/or private) interest groups by contract law or social consent. *Communication* attempts to persuade and educate members of or those affected by the regulated community. Communication-based tools enrich the information to the targeted audience. Finally, regulation by *code* operates through the design of technological architecture; it eliminates undesirable behaviour by designing the unwanted occurrence out of the technology.

The summary of the modality mix presented in the Modality Mix Article (see Part Two) can be extended by the two additional views of Scott (2004) and Bronwen & Yeung (2007) discussed in this section; see Table 10:

	Lessig (1999)	Hübner-Fischer (2000)	Scott (2004)	Reding (2006)	Bronwen & Yeung (2007)
Modalities	Law	Law	Hierarchy	European rules	Command
	Norm	Fair information practices (FIP)	Community	Self-regulation	Consensus
	Market	–	Competition	Industry	Competition
	Architecture	Privacy enhancing technology (PET)	Design	Privacy enhancing technology (PET)	Code
	–	–	–	–	Communications

Table 10: Extension of the different terminologies for the same modalities of regulation.

3.2.3 Applying Regulation

Telecommunications regulation was originally based on the belief that the telecommunications service could only be provided by one or limited number of operators. Technological advancements and increase in the demand of telecommunications services allowed a more competitive approach (Wu, 2008). As compared to the regulation of the telecommunications industry, the Internet has deliberately not (yet) been regulated heavily. However, a shift from non-regulation to co-regulation between industry self-regulation and governmental regulation is becoming apparent. In the USA a non-regulatory, market-oriented approach to the development of the Internet and e-commerce with minimal governmental involvement was sought. The US government encouraged industry self-regulation and refrained from imposing new, unnecessary technology-specific regulations on Internet activities (Lips, 2006). There has, however, been a tendency to co-regulation besides industry self-regulation because the “essential claim is that the Internet is too important not to regulate” (p. 12) (Litan, 2001). In Europe, a strong preference could be perceived in the past decade to let the private sector have the lead in the development of the information society. For instance, offline legal frameworks should apply online, avoiding unnecessary regulation. But any regulatory framework should strike the right balance between

freedom of expression and the protection of private and public. The OECD initially decided that legislation should primarily serve to facilitate the development of the electronic environment. Then there was a shift in the regulatory approach advocating co-regulation and an integrated approach. A balance should be sought between industry self-regulation and regulation by governments, businesses and the public (Lips, 2006).

Because of the technology convergence in ICT, several regulatory approaches used in the telecommunications sector (Buckley, 2003) can be adapted for other ICT environments. Hence, also for RFID can the following regulatory approaches be recognised in various national governments and international organisations:

1. General legal frameworks should hold online as they hold offline. This means that the Internet is not above the law and that offline regulation should be tried to be applied online (Schellekens, 2006). An advantage could be consistency, legal clarity, and legal certainty (at least the same as offline); a drawback could be stagnating legislative progress or unclear, or even questionable, comparison of the online situation with the offline situation (Schellekens, Koops, & Prins, 2006).
2. ICT regulation should not only be driven by governments, but the industry should have the duty of self-regulation (see Table 10). Self-regulation is the regulation and coordination of behaviour through rules of organisations or through the application, compliance, and enforcement of such rules. Four types can be distinguished: pure self-regulation, proxy self-regulation (i.e., government pressure on industry), legally stipulated self-regulation, and co-regulation together with government. Standards (see Section 2.3), for example, are self-regulatory means (Koops, Lips, Nouwt, Prins, & Schellekens, 2006). An advantage could be fast(er) reaction times due to the involvement of the industry; a drawback could be legitimacy, enforceability, and sustainability (Schellekens et al., 2006).

3. ICT regulation should be technology-neutral. Thereby regulation, whether specifically for ICT or not, should not regulate the technology itself, but the *effects* of the use of technology. In principle it is the same as offline regulation. For example fraud is actionable in many jurisdictions regardless of the tools with which it was committed. Generally, ICT regulation should not discriminate against different technologies. ICT regulation should be sustainable, especially as technology develops much faster than legislation is enacted (Koops, 2006). An advantage would be longevity of the regulation; a drawback could be sweeping regulation at the cost of certainty (Schellekens et al., 2006).
4. ICT regulation should be harmonised at an international (but not necessarily also global) level. Thereby the meaning is twofold: on the one hand, the level of organisation is international, e.g., established by an international institution; on the other hand, the effect is international, e.g., the coordination of national rules. International regulation would require a balance between social, cultural, economic, and individual diversity (Prins, 2006). An advantage could be a unified territorial scope; a drawback could be issues with sovereignty, as well as with national values and traditions (Schellekens et al., 2006).
5. ICT could be regulated by means of technology, specifically code (e.g., digital rights management (DRM) or privacy enhancing technologies (PET), see Table 10). Because in the realm of the Internet, the underlying technology is code, it could be claimed that the real rule makers are the software engineers. In this sense, code regulates via the technical architecture and (allegedly) has legal consequences. The influence in the code can come, for instance, from international organisations, such as W3C, IETF, ICAAN, or from companies, such as Microsoft or Google (van der Hof & Stuurman, 2006). An advantage could be the growing importance of the factual context of code; a drawback could be the lack of transparency or legitimacy (Schellekens et al., 2006).

3.3 Chapter Summary

Chapter 3 attempts to define innovation and regulation. Adoption is defined as the acceptance of a specific innovation; diffusion is defined as the cumulated adoption over time. An overview of ten different adoption and diffusion theories and models, viz. TRA, TPB, MPCU, SCT, TAM, TAM2, C-TAM-TPB, IDT, PCI, and UTAUT with their corresponding characteristics, is presented. Regulation and its antonym deregulation are outlined from three different viewpoints: economic, legal, and socio-political. It is suggested that technological innovation be regulated by different regulatory means, such as law, social norms, market, and architecture.

Chapter 4

Research Method

Chapter 4 provides an overview of the research method of this thesis. It starts by discussing Burrell & Morgan's (1979) contentious paradigm quadrant (Section 4.1). Second, one school of thought per paradigm is exemplified (Section 4.2). Third, the approach of Burrell & Morgan (1979) is inverted deliberately by placing RFID as technology into the paradigm quadrant (Section 4.3). Fourth, paradigm incommensurability is discussed (Section 4.4) which leads to the analysis of pragmatism as philosophical approach (Section 4.5). Finally, abduction as third method of reasoning is suggested for this research project (Section 4.6).

4.1 Two Dimensions – Four Paradigms

It is recommended that anyone who does research in any field must come to grips with two fundamental problems in his / her pursuit of knowledge (Goles & Hirschheim, 2000): “how do we know what we know’ and ‘how do we acquire knowledge’” (p. 250). Researchers must choose the rules under which they do research (Mingers, 2001). Hence, before delving into the material research for this thesis, the philosophical / sociological paradigms of research in the field of RFID shall be explored. It is only after having defined these paradigms that one is able to select the right research method. “A paradigm is what the members of a scientific community share, and, conversely, a scientific community consists of men [and women] who share a paradigm” (p. 176) (Kuhn, 1970 in: Mohanan). Such a scientific community can share, for example, research interests, value systems, theories, models, bodies of facts, theoretical frameworks, or observational frameworks (Mohanana).

The exploration of the paradigm answers the question about a researcher's underlying philosophical perspective and his or her meta-theoretical assumptions that will guide the *research* (in this case) of technological innovation and regulation by law. It does not answer the question about technological innovation and regulation by

law *itself*. This latter question can only be answered once the meta-theoretical assumptions have been explored. To this extent, technological innovation itself, for instance, is an ontological, not a paradigmatic, notion. Exploring the paradigm will answer the question how a research subject is approached. It will not answer the research subject itself.

The *starting point* of this preparatory journey for the methodological approach of this thesis is the seminal, but contentious, work of Burrell & Morgan (1979) on the analysis of social theory. Burrell & Morgan's paradigm quadrant (Figure 9) gives a good and structured overview of the different paradigms. Burrell & Morgan (1979) argue that all theories are based upon a philosophy of science and a theory of society. The former yields a dimension of subjectivity versus objectivity; the latter yields a dimension of sociology of radical change versus sociology of regulation. This leads to the four paradigms of radical humanism, radical structuralism, functionalism, and interpretivism within which a researcher can be placed (Figure 9). It is suggested that to be located in a particular paradigm is to view the world in a distinct way.

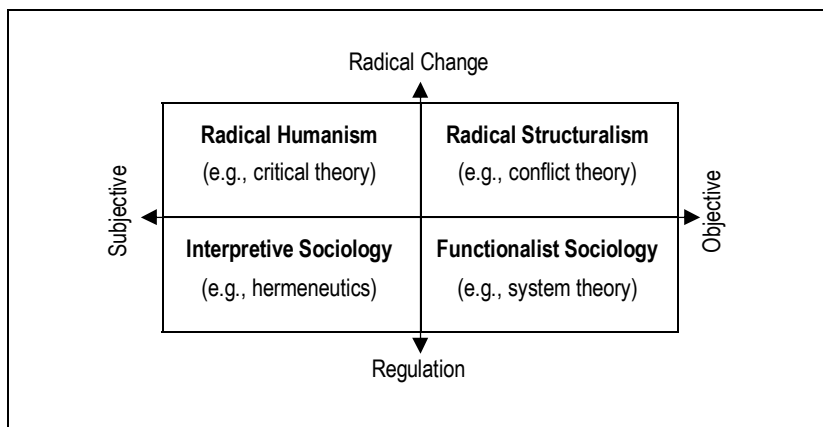

Figure 9: Paradigm quadrant with examples of schools of thought (adapted from Burrell & Morgan (1979)).

Within the vertical *radical change – regulation dimension* (Figure 9), also known as order – conflict debate, the underlying unity of sociology of radical change is a sociology that is essentially concerned with the emancipation from structures that hinder potential development. It focuses on what is possible rather than what is. It is aimed at changing the world rather than only understanding it (Burrell & Morgan, 1979). This dimension is predicated upon the view that society is a potentially dominating force (Morgan, 1980).

The *radical humanist paradigm* is based upon a common concern for the freedom of human spirit. As a subjective paradigm the radical humanist paradigm follows the notion that the ultimate reality of the universe is spiritual rather than material in nature (Burrell & Morgan, 1979). It seeks radical change, emancipation, and potentiality. It stresses the role that different social and organisational forces play in understanding change (Goles & Hirschheim, 2000). The different schools of thought in the radical humanist paradigm, among others that of critical theory, emphasise that reality is socially created and socially sustained. Radical humanists are concerned with the alienation of the people that are dominated by the superstructures with which they interact (Burrell & Morgan, 1979).

In contrast, the *radical structuralist paradigm* is rooted in a materialist view of the natural and social world: nature of reality exists outside the minds of the people. Radical structuralism provides a critique of the status quo in social affairs and tries to change it (Burrell & Morgan, 1979). It has a view of society and organisations that emphasises the need to overthrow or transcend the limitations placed on existing social and organisational arrangements (Goles & Hirschheim, 2000). Economic or political crises generate conflicts that disrupt the status quo and are subsequently replaced by radically different social forms. The radical structuralist schools of thought, among others that of conflict theory, follow four notions: totality, structure, contradiction, and crisis (Burrell & Morgan, 1979).

Within the horizontal *subjective - objective dimension* (Figure 9), the underlying unity is an approach via either explicit or implicit assumptions about the nature of the social world. Sociology of regulation is concerned with the need for regulation in human affairs. It attempts to explain why society tends to hold together rather than fall apart (Burrell & Morgan, 1979).

The *functionalist paradigm* is concerned with the effective regulation and control of social affairs and emphasises the importance of understanding order, equilibrium and stability in society (Burrell & Morgan, 1979). It is concerned with providing explanations of the status quo, social order, social integration, consensus, need satisfaction, and rational choice (Goles & Hirschheim, 2000). The schools of thought of functionalism, among others that of social system theory, share the standpoint of the observer and attempt to relate what they observe. They assume that there are general external and universal standards of science that can serve as a basis for determining what was observed. The paradigm is based upon a fundamental commonality of perspective in terms of basic, taken for granted assumptions. Objective enquiry can provide true explanatory and predictive knowledge of the external reality by the assessment of empirical evidence (Burrell & Morgan, 1979).

The *interpretivist paradigm* concentrates on the study of how social reality can be constructed and ordered meaningfully from the point of view of the actors directly involved in the social process (Burrell & Morgan, 1979). It seeks explanation within the realm of individual consciousness and subjectivity (Goles & Hirschheim, 2000). The schools of thought of the interpretive paradigm, among others that of hermeneutics, try to understand the subjective experience of individuals, i.e., the individual as actor, not as observer (Burrell & Morgan, 1979).

These four paradigms differ from one another in many ways as they are based on fundamentally distinct assumptions. But at the same time they also share similarities. Interpretivism and radical humanism share the notion that people create the world in which they live. However, whereas interpretivism merely tries to understand the nature of this process, radical humanism subjects the process to critique. Functionalism and radical structuralism both emphasise the concrete nature that exists outside the minds of the people. However, they differ in that radical structuralism provides a critique on the status quo of contemporary society and tries to change the world, not just understand it as functionalism does. Functionalism is merely concerned with evolutionary, not catastrophic change.

4.2 The Four Schools of Thought Applied

Burrell & Morgan (1979) contend that the four paradigms are *mutually exclusive*: “A synthesis [of the four paradigms] is not possible, since in their pure forms they are contradictory, being based on at least one set of opposing meta-theoretical assumptions” (p. 25) (Burrell & Morgan, 1979). The question that inevitably follows is which paradigm is the right one for this thesis. Which paradigmatic approach (see Figure 9) will guide this interdisciplinary research on technological innovation, regulation by law, and RFID as base case? One school of thought per paradigm shall be analysed in the following: Critical theory within the radical humanist paradigm, conflict theory within the radical structuralist paradigm, system theory within the functionalist paradigm, and hermeneutics within the interpretivist paradigm.

4.2.1 Critical Theory

First, *critical theory* is a brand of social philosophy which seeks to operate simultaneously at a philosophical, a theoretical, and a practical level. It focuses on the forms and sources of the alienation that inhibits the possibilities of human fulfilment. It is oriented at critiquing and changing society as a whole. Critical theory is the examination and critique of literature and society based on social sciences and humanities. It emphasises the importance of the theorist’s commitment to change, rather than just to understand. The Frankfurt School demonstrates and critiques the way that *superstructures* of modern capitalist social formations, such as technology or law, are to be understood in relation to the role they play in sustaining and developing the system of power and domination that pervades the totality of the social form. The superstructure of capitalist society is the medium through which the consciousness of human beings is controlled and moulded to fit the requirements of the social formation as a whole (Burrell & Morgan, 1979).

From a critical theory viewpoint, both technological innovation and regulation by law could be characterised as surplus repressions from which society must be rid of in order to achieve human emancipation. One could argue that not only technological innovation but also regulation by law imposes itself upon society. Industry players like, for instance, the US Department of Defence (DoD) or Wal-Mart are

requesting that their suppliers implement RFID technology if they seek to continue to do business with them (___, 2003). Moreover, (currently) approximately 60 governments worldwide have implemented legislation to issue biometric passports equipped with RFID technology (see Section 2.5). These two examples taken as superstructures of capitalist society, do they really impose their power to control and mould the *consciousness* of the people? This is doubted by the author. Likewise it seems questionable whether RFID is the wedge of alienation that divorces society's consciousness and the objectified social world. However, it does not seem far-fetched to assume that governments would like to have as much information about "their" citizens as possible. In Switzerland, for instance, the political debate regarding the introduction of the ePass was not fought because the RFID tag was to be placed in the passports but because a *central database* of the Swiss government will store the data of "its" citizens (met, 2009).

4.2.2 Conflict Theory

Second, *conflict theory* examines class conflicts and the influence and control over others. On the one hand, the perspective of class conflicts can explain the degree and nature of social integration; on the other hand, it can explain why the social system is in the process of change and disintegration. The former perspective is manifested in the *superstructure* of the social formation, where the interests of different power groups (e.g., political, legal, or administrative apparatus) are most evident. The latter perspective focuses on the *substructures* or economic base of society to understand the contradictions that act as generators of social change and disintegration (Burrell & Morgan, 1979).

Characteristics of the conflict theory by John Rex (Burrell & Morgan, 1979) could be applied to the technological innovation and regulation by law of RFID:

1. The conflict situation could lie somewhat between peaceful bargaining, such as negotiation of standards (EPCglobal Inc.,) or legislation (Commission of the European Communities, 2008) by the subjects involved, and open violence, such as demonstrations and boycotts by the (allegedly) subjected class (Albrecht & McIntyre; Albrecht).

2. The plural society that possibly evolves therefrom could, for instance, be the leading RFID industry (e.g., Wal-Mart or the US DoD), the suppliers of the leading RFID industry, and the users.
3. Inequality could emerge because of a (perceived) discrepancy of power regarding the implementation of RFID, be it legal or technological, for instance, the legislative power on regulation of technological innovations.
4. The power situation between the different classes can change, such as, for instance, the political legislative power of RFID legislation, or the power by the lobbying RFID industry, or the power by the endusers.
5. In case of a dramatic change of power by, for instance, the subjected class, RFID legislation could be changed or repealed, or the RFID industry could be forced by negative press to withdraw certain goods from the market (C.A.S.P.I.A.N.).
6. Finally, the change of balance might not lead to complete revolution, but could lead to compromise and reform, hence, institutions that might be recognised as legitimate by all classes involved.

4.2.3 System Theory

Third, *system theory*, which is the application of system theoretical body of thoughts to tangible problems (Klaus, 2007), is an interdisciplinary field of science. It studies complex systems of nature, science, and society. “[The] subject matter [of system theory] is the formulation and derivation of those principles which are valid for ‘systems’ in general” (p. 31) (von Bertalanffy, 1971). Cybernetics is a (sub-) category of system theory, deriving not from biology-like system theory but from control systems. It is the science of structure, relation, and performance of dynamic systems (Klaus, 2007). Two different systems are important in the context of system theory: closed systems and open systems. Closed systems are systems that are isolated from their environment. They must, according to specific laws of physics, eventually reach a state of equilibrium. Open systems are characterised by an exchange with their environment. They exchange themselves with the environment by exports and imports. A state of equilibrium will likely not be reached (Burrell & Morgan, 1979).

System theory could be applied to this thesis research. RFID systems are, similarly to the system theory approach, differentiated by closed-loop and open-loop systems. In the closed-loop system, an RFID-tagged object is shipped or moved in a cycle and eventually returns to its place of origin (Schmitt, Michahelles, & Fleisch, 2008). The tagged object may be re-used for the same or similar tasks (Schmitt, 2008). Closed-loop systems are often implemented within or between enterprises or organisations. Examples for such closed-loop systems are the management of valuable assets, tools, returnable containers, or inventory management pallets (Schmitt, Michahelles, & Fleisch, 2008). In open-loop systems, the RFID tag likely remains on an object and leaves the process or production site without reuse for the same process (Schmitt, Michahelles, & Fleisch, 2008). Open-loop systems are often implemented in supply chains across various enterprises or organisations and will often also include the end customer. Examples are one-way recyclable packaging or apparel labelling (Schmitt, 2008).

4.2.4 Hermeneutics

Fourth, *hermeneutics* studies the interpretation and understanding of products of the human mind, such as written texts of literature, religion, or law. It is the field of philosophy most concerned with investigating the nature of understanding and interpretation (Hoy, 1985). It adopts the style of literary analysts rather than natural scientists. One can indeed attribute a particular meaning to words. However, such meaning will differ in the context of other words. The approach is that the social whole cannot be understood independently of its parts, and each individual part cannot be understood without reference to the whole; it is a circle (Burrell & Morgan, 1979).

Legal systems thrive on interpretation of legal texts. So hermeneutics seems self-evident in law. However, it has been criticised that “the mere fact that ‘law’ appears as an adjective in [the] title [legal hermeneutics] does not necessarily render it relevant to legal argument” [...] Just as legal theorists often fail to appreciate the complexities of legal phenomena, lawyers often fail to appreciate the complexities of the hermeneutical tradition” (p. 386) (Sherman, 1988). Despite this criticism, it is held here that the interpretation and understanding of legal texts, whether in the narrow or wide sense (see Section 4.3), are imperative in jurisprudence. Interpretation of legal

texts (e.g., legislation or contracts) is necessary and commonly based on wording, taxonomy, evolution, and teleology (Klaus, 2007).

4.2.5 Outcome of the Application of Schools of Thought

Applying critical theory, conflict theory, system theory, and hermeneutics shows that any of these four schools of thought could be used in this interdisciplinary thesis. No one paradigm suits solely. This is not surprising because belonging to any one paradigm means sharing a scientific view with the members of that paradigm. The preference in this thesis is to use a mixed approach.

4.3 Inverting the Approach

The preceding sub-section tried to outline the question which rules are applicable for the research in this thesis. It concluded that no one paradigm should be solely applicable. In this sub-section, the use of the four standpoints of philosophy of science – ontology, epistemology, human nature, and methodology – shall be used in an inverted manner. The goal of this inversion is to verify whether one will come to the same conclusion as in the preceding sub-section, viz. that a paradigm mix is appropriate.

In a nutshell: ontology refers to the nature of the world and is either nominalist or realist; epistemology is the way in which one acquires knowledge and is either anti-positivist or positivist; human nature (also referred to as axiology) is about the value of the research and is either voluntarist or determinist; and methodology finally is the mechanism for acquiring knowledge and is either ideographic or nomothetic (Burrell & Morgan, 1979; Goles & Hirschheim, 2000).

RFID development is divided into two main camps: the one of the (technological) innovators and the one of the regulators (by law). Each of these main camps can be divided further in a narrow and wide sense. The latter view includes all of the former, and extends it further. It is assumed that the delimitation between the narrow and the wide sense is a grey zone. The industry driving the technological research and development of RFID is referred to here as *technological innovation in the narrow sense*. The adoption and diffusion of technological innovation of RFID, which build on and use the results of

the technological innovation of RFID in the narrow sense, are referred to as *technological innovation in the wide sense*. Similarly, the regulators of law, for instance, the legislator and judiciary, that enact the law are referred to as *regulation by law in the narrow sense*; whereas advocacy and standardisation bodies that use and interpret law on RFID are referred to as *regulation by law in the wide sense*. Table 11 summarises these different views of technological innovation of RFID and RFID regulation by law.

Scope \ Discipline	Technological Innovation of RFID	RFID Regulation by Law
Narrow sense	Research and development of technological innovation of RFID	Legislation and adjudication
Wide sense	Technological innovation of RFID in narrow sense plus, e.g., adoption and diffusion of the technological innovation of RFID	Regulation by law in narrow sense plus, e.g., negotiating and contracting with regard to RFID or standardisation bodies

Table 11: Summary of technological innovation of RFID and RFID regulation by law, each in the narrow and the wide sense.

4.3.1 Ontology

The question of the ontology of RFID is an interesting one because radio frequency waves per se are not visible to humans. Neither is the data contained in the tag that is transmitted to the reader. The radio frequency waves can be triggered without human interaction: an RFID tag transmits the data contained in it to a corresponding reader as soon as it is within the read range of the reader (see Section 2.2). The radio waves and the data transmitted are physically present regardless of whether they can be perceived or appreciated by humans. So how do we research RFID? Here it is argued that for the researcher the world of technological innovation of RFID in the *narrow sense* is a real structure independent of its labelling. In contrast, technological innovation of RFID in the *wide sense* includes adoption

and diffusion. RFID systems are built, implemented, and deployed by humans based on the technological innovation of RFID in the *narrow sense*. However, as it is not possible to perceive the waves and transmitted data per se without auxiliary systems, it is necessary to assign names, concepts, and labels to make them visible and usable.

From an RFID regulation by law perspective, labelling seems necessary. Here it is argued that the legal structure in the *wide sense* is not something that is metaphysically given: it is constructed by society. The physics of a radio wave are the same in North America, in Europe, and in Asia. But the way in which these waves may be used is different. For example, from a radio frequency perspective the world is divided into three regions: region 1 covers Europe, Africa, and the northern part of Asia; North and South America make up region 2; and region 3 comprises the southern part of Asia, Australia, and Oceania (ITU, 2005). However, even though the ITU regulates the frequencies, a uniform allocation of RFID-dedicated frequencies in the three regions is not possible because of historically different frequency allocations, e.g., for television or mobile phones. This example shows that despite the identical underlying physical aspects of the technological innovation of RFID, RFID regulation by law fosters different metaphysical uses of the technological innovation of RFID. These differences in use are the result from the different names, concepts and labels given to technological innovation of RFID by RFID regulation by law in the *wide sense*.

As interim conclusion, it is retained that under an ontological assumption (i) technological innovation of RFID in the narrow sense can be favourably studied in the *functionalist* and/or *radical structuralist* paradigm; and (ii) RFID regulation by law in general and technological innovation of RFID in the wide sense can be favourably studied in the *interpretivist* and/or *radical humanist* paradigm.

4.3.2 Epistemology

How do we acquire knowledge about technological innovation of RFID and RFID regulation by law? It is argued that whereas technological innovation of RFID in the *narrow sense* falls within the objective dimension of positivism because the physical structures of RFID are given through causal relationships observed by scientists,

technological innovation of RFID in the *wide sense* tends to be of more subjective nature. Here the researcher influences events by implementing and deploying technological innovation of RFID. Social interactions are required. To understand the problems and requirements of an RFID system, it is vital not only to observe from a distance but also to interact as a participant in and with the entire adoption and diffusion process.

RFID regulation by law in the *narrow sense*, on the one hand, could possibly be seen as a rather objective dimension due to constitutional law and the decisive judiciary systems. The amount of influence people have hereby depends on the political and legal system in a specific territory. Court decisions also become final at a certain appellate court and point in time. The knowledge is acquired without much influence from the observer. Generally, no one should stand above the law. This positions RFID regulation by law in the *narrow sense* into the objective and positivist dimension. On the other hand, RFID regulation by law in the *wide sense* seems to be more anti-positivist. For instance, the implementation of standards is driven by the industry partners themselves. They can take direct influence on the structuring of the standard and thereby acquire the knowledge. Their involvement is thus not only as observer but also as participant and active stakeholder.

As interim conclusion, it is retained that from an epistemological view both technological innovation of RFID and RFID regulation by law in the wide sense are favourably researched in the *interpretivist* and/or *radical humanist* paradigm, whereas RFID technological innovation of RFID and RFID regulation by law in the narrow sense are well researched in the *functionalist* and *radical structuralist* paradigm.

4.3.3 Human Nature

Technological innovation of RFID can be used to streamline processes by substituting manual work with radio frequency technology. Data can be transmitted wirelessly. But the wireless technology does not work equally in all environments or situations. Metal, on the one hand, reflects radio waves. Water, on the other hand, absorbs these waves. Different materials have varying effects on radio waves (Sood, 2007). These are physical laws that determine

how technological innovation of RFID can be used (technological innovation of RFID in the *narrow sense*). But also in technological innovation of RFID in the *wide sense* is this technology determined by the environment. Successful adoption and diffusion of RFID must follow certain physical rules. Such physical rules cannot be omitted. Use of technological innovation of RFID in logistics or supply chain management, for instance, will in general require that the supplier of goods adapt the packaging of certain products to achieve optimal read results. Canned food (tins) or bottled liquid, for example, is difficult to tag because of the physical influence of metal and water on radio waves. Read accuracy will be insufficient if certain precautionary measures, such as encasing packaging or use of special tags, are not taken into consideration (Sood, 2007).

Similarly to the epistemological analysis, RFID regulation by law in the *narrow sense* can be viewed as predetermined by either the legislative or the judiciary. Law and court decisions come into force. Violation of such rules is in general sanctioned. RFID regulation by law in the *wide sense* is more flexible. Whereas non-profit organisations, like EPCglobal Inc. or ISO, are determined to provide rules, such as, for instance, a standard for the electronic product code, it remains the free will of the market players to decide whether to adopt such a standard. If RFID regulation by law in the *wide sense* becomes a worldwide standard, then de facto a market player will need to adopt such standard. But the necessity to adopt the standard does not shift RFID regulation by law in the *wide sense* into the objective dimension (determinism); it remains the free will and in the subjective dimension (voluntarism).

As interim conclusion, it is retained that from a human nature view RFID regulation by law in the wide sense is favourably researched in the *interpretive and/or radical humanist* paradigm. RFID regulation by law in the narrow sense as well as technological innovation of RFID in both the narrow and wide sense are well researched in the *functionalist and/or radical structuralist* paradigm.

4.3.4 Methodology

Technological innovation of RFID will mostly be based on natural sciences. The nomothetic approach will prevail for technological innovation of RFID in the *narrow sense*. Because technological innovation of RFID is partly ephemeral, research on technological innovation of RFID needs to be based on systematic protocol and scientific tests. However, the research methodology for technological innovation of RFID in the *wide sense* and RFID regulation by law in general will be more flexible and allow both a nomothetic and an ideographic approach. Depending on what the research question is, an analysis of subjective accounts but also the use of quantitative techniques are appropriate.

The methodological debate will be analysed further in the next subsection. As interim conclusion, however, it is held that from a methodological view technological innovation of RFID in the narrow sense is favourably researched in the *functionalist* and/or *radical structuralist* paradigm, whereas technological innovation of RFID in the wide sense as well as RFID regulation by law in the narrow and wide sense can be researched in all four paradigms.

4.3.5 Outcome of the Inversion

The outcome is that also in this inverted philosophy of science approach, in which RFID - as base case of this thesis - has been placed into the paradigm quadrant, are the paradigms not fixed, neither for technological innovation of RFID nor for RFID regulation by law. Depending on the meta-theoretical assumption and depending on whether the approach employed is RFID regulation by law in a wide or narrow sense, or technological innovation of RFID in a narrow or wide sense, respectively, the underlying paradigm can be either radical humanist, radical structuralist, interpretivist, or functionalist.

The preceding discussion on the meta-theoretical assumptions has not resulted in any clear-cut allocation favouring any of the paradigms. Not only is there no clear distinction between the assumptions for technological innovation and regulation by law, where one might have earlier jumped to the conclusion that RFID regulation by law is interpretive and technological innovation of RFID is functional, also in

the two scientific fields of technological innovation and regulation by law themselves there is no unity in favour of any paradigm.

Table 12 summarises the evaluation of the meta-theoretical assumptions based on the two main distinctions of technological innovation and RFID regulation by law. A “✓” indicates the placement of a standpoint in a paradigm.

Paradigm Standpoint	Radical Humanist Paradigm Interpretive Paradigm				Radical Structuralist Paradigm Functional Paradigm			
	Ontology		✓	✓	✓	✓		
Epistemology		✓		✓	✓		✓	
Human nature				✓	✓	✓	✓	
Methodology		✓	✓	✓	✓	✓	✓	✓
	Narrow sense	Wide sense	Narrow sense	Wide sense	Narrow sense	Wide sense	Narrow sense	Wide sense
	Technological innovation of RFID		RFID regulation by law		Technological innovation of RFID		RFID regulation by law	

Table 12: Summary of meta-theoretical assumptions and paradigm allocation.

4.4 Paradigm Incommensurability

The results of the application of the four schools of thought (Section 4.2) and the inverted approach (Section 4.3) show that no one paradigm or school of thought seems solely appropriate for the research in this thesis. The dominance of a single perspective does not fully reflect the multi-faceted nature of reality. The work of Burrell & Morgan (1979) has been used to show the absence of a unifying paradigm. Paradigmatic unity is viewed as fundamentally undesirable as it is done at the price of constraining the domain of inquiry by taking one viewpoint only (Goles & Hirschheim, 2000). Paradigm isolationism (Mingers, 2001) is thus not justified.

The list of opponents of paradigm incommensurability is long (see references in Goles & Hirschheim (2000)). Proponents of multi-paradigm perspectives have suggested approaches by a wide range of research groups, such as mainstream navigators, unity advocates, knights of change (Landry & Banville (1992), in: Goles & Hirschheim (2000)), pacifists (Goles & Hirschheim, 2000) or pluralists (Mingers, 2001). There are strengths and weaknesses on either side of meta-theoretical assumptions. According to Shank (1989), Peirce (1955) seems to claim that one's mind is a device that is used to reason about the nature of the external world and the internal world; therefore it belongs to neither the subjective (qualitative) nor the objective (quantitative) world. Hence, the mind can have no claim to privileged knowledge regarding either domain. This leads to a multi-paradigm understanding where conflicting paradigms can coexist. This coexistence is based upon the philosophical school known as pragmatism. Pragmatists select the approach and methodology most suited to a particular research question, be it qualitative or quantitative (Goles & Hirschheim, 2000). The following section treats the principal theory of the philosophical movement known as pragmatism.

4.5 Pragmatism

Pragmatism is an account of how people think and how they come up with ideas, form beliefs, and reach decisions (Menand, 2004). Pragmatism (also pragmaticism (Peirce, 2004 (1906))) was coined by Peirce (2004 (1878)). The term pragmatism was popularised subsequently by James (2004 (1904), 2004 (1907)). For Peirce any truth was provisional; the truth of any proposition cannot be certain but only probable. According to James (2004 (1907)), the pragmatic method is primarily a method of settling meta-physical disputes that otherwise might be interminable. It tries to interpret each notion by tracing its practical consequences. If no practical difference whatsoever can be traced, the dispute is idle because the alternatives mean the same thing (James, 2004 (1907)).

Peirce insisted that besides deduction and induction there was a third basic form of inference. He stipulated a three-fold classification of modes of reasoning and referred to the third mode by various names, but mostly hypothesis, *abduction*, or retroduction (Paavola, 2006).

Pragmatism and abduction are connected in that abduction “shades into perceptual judgment without any sharp line of demarcation between them” (Peirce, 1931-1958, in: Paavola, 2006). Abductive inferences and perceptual judgments thus involve important common elements: they both have characters proper to interpretations (Paavola, 2006).

After Peirce’s death, abduction only attracted marginal interest. Norwood Russell Hanson (1961) was allegedly the first to seriously start developing Peirce’s abduction as a way of conceptualising the area of discovery. He maintained that discovery was an important research area. Hanson argued that “before having hit a hypothesis which succeeds in its predictions, one can have good reasons for anticipating that the hypothesis will be one of some particular kind” (p. 23) (Hanson, 1961, in: Paavola, 2006). The following sub-section will discuss abduction as the third mode of reasoning.

4.6 Abduction

Science can be described as the convention, related societal norms, expectations, and values that are used to engage in a search for understanding (Goles & Hirschheim, 2000). Typically, there are two ways to construct and apply knowledge: induction and deduction (see Figure 10).

Induction builds on empirical data. Phenomena are observed and studied, and are then used to create a model or theory (Rasmussen, Oestergaard, & Beckmann, 2006). Induction generalises from a number of cases for which something is true and then infers that the same is true for a whole class (Cooke, 2006). Induction is the process of deriving the result of what is assumed. *Deduction* builds on a set of assumptions, mostly in the form of a model or a theory. Then these assumptions are verified or falsified with empirical data (Rasmussen et al., 2006). Deduction illustrates what necessarily follows from accepting a premise but it does not convey new knowledge (Cooke, 2006). Often there is a combination of induction and deduction (Rasmussen et al., 2006).

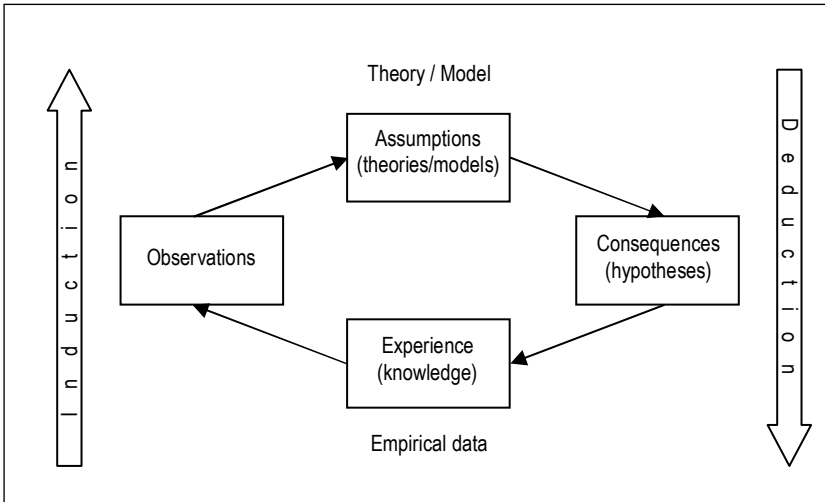

Figure 10: Relationship of induction and deduction (adapted from Rasmussen et al. (2006)).

It is claimed that today new ways to understand the world are sought. Matters of meaning cannot be explained ahead of time. On the one hand, such matter of meaning should be allowed to float free; on the other hand, patterns of ordinary meaning should be established to generate new insights that lead to more sophisticated levels of meaningful understanding. A logical tool seems necessary (Shank, 1998). The logic of the analysis consists of replacing neither deduction nor induction but rather of adding *abduction* as tool of reasoning that is related systematically to both deduction and induction (Cooke, 2006):

1. induction shows that something *actually is*;
2. deduction proves that something *must be*; and
3. abduction suggests that something *may be*.

Abduction, as third mode of reasoning, is weaker than either deduction or induction; it is a weak form of inference which asserts "its conclusion only problematically or conjecturally" (Peirce, 1931-1958, in: Paavola, 2006). Abduction is the process of inferring a precondition from an explanation. Hence, the conclusion in abduction

is *only probable*; it is *itself a conjecture* (Cooke, 2006). “An argument is fallacious only so far as it is *mistakenly*, though not *illogically*, inferred to have professed what it did not perform” (own emphasis) (Cooke, 2006). It is important to note that the idea of abduction is linked to ordinary experience and not to theory testing per se. Therefore abduction is ultimately an explanation of how ordinary circumstances are the way they are (Shank, 1998).

Compared with deduction, which is the inference of the result from the rule and the case, and induction, which is the inference of the rule from the case and the result, abduction is the inference of the case from the result and the rule. Table 13 illustrates the differences between deduction, induction, and abduction (Shank, 1998):

Mode of reasoning	Order of reasoning	Examples
Deduction:	Rule:	It is true that when it rains the grass is wet.
	Case:	We know that the grass is wet.
	Result:	Certainly, it is true that it rained.
Induction:	Case:	We know that the grass is wet.
	Result:	We have observed that it rained.
	Rule:	Probably then, when it rains the grass is wet.
Abduction:	Result:	We have the experience that it rained but this experience lacks any real meaning for us.
	Rule:	The claim that when it rains the grass is wet is meaningful in this setting.
	Case:	Therefore, it is both plausible and meaningful to hypothesise that the grass is wet.

Table 13: Examples of deduction, induction, and abduction (adapted from Shank & Cunningham (1996)).

Summarising, one can state that abduction's purpose is to generate guesses that induction can evaluate and that deduction can explicate. In logical abduction, in a first premise, one encounters a surprising fact. In a second premise one posits a hypothetical claim about what causal relation would explain the anomaly and render the surprising fact of the first premise simply a matter of course. Finally, in the last premise, one infers that this case is probably true, in order to explain the surprising fact of the first premise (Cooke, 2006).

4.7 Chapter Summary

Chapter 4 provides the research methodology of this thesis. Based on the paradigm quadrant by Burrell & Morgan (1979) it is argued that no one school of thought (e.g., critical theory, conflict theory, social system theory, or hermeneutics) and consequently no one paradigm in specific (e.g., radical humanism, radical structuralism, functionalist sociology, or interpretive sociology) is applicable but that rather a mix of paradigms is favourable for this interdisciplinary research. Such coexistence is based on the philosophical school of pragmatism. Pragmatism allows for a – besides deduction and induction – third mode of reasoning: abductive reasoning. Abduction is a weaker form of inference. It is the inference of a precondition from an explanation. Abduction is used as research methodology for this thesis.

Chapter 5

Data Collection

Chapter 5 provides an overview of the data collection in the individual research articles. Following pragmatism, a multi-method approach is advocated for this paper-based thesis (Section 5.1). The data collected in the Database Article (Section 5.2), Marketing Article (Section 5.3), Modality Mix Article (Section 5.4), the Survey Article (Section 5.5), and the Concept Article (Section 5.6) are presented. Finally, some caveats are outlined regarding the interpretation of the empirical data of this research project (Section 5.7).

5.1 Paradigm Mix

Pragmatism provides an attractive approach to meet the demand for increased interplay between research and practice (Goles & Hirschheim, 2000). The European Commission, for instance, promotes the knowledge triangle between research, education and innovation as a core factor in European efforts to meet the ambitious Lisbon goals of becoming the “most dynamic and competitive knowledge-based economy in the world capable of sustainable economic growth with more and better jobs and greater social cohesion, and respect for the environment” (p. 3) (Barroso & Verheugen, 2005). Since 1984, industry and academia have joined forces for research covering almost all scientific disciplines (European Commission, 2008). Another example of how the joint forces of industry and academia are promoted is the Doctor of Business Administration (DBA) programme itself. This relatively young route to a PhD is designed specifically for executives who wish to concentrate on an academic field of research. The DBA aims for and fosters exactly this interplay between industry and academia as advocated by Goles & Hirschheim (2000):

“The purpose of the DBA program is to train business executives in the field of economics and business administration to provide them with the competencies to pursue academic, business and public administration

careers that require research skills and qualifications. [...] Since participants continue their full-time jobs in business and other organizations throughout their doctoral studies, an important aspect of the program is the creation of professional networks across and between industry and academia.” (CBS, 2008)

On the one hand, the multi-method research approach meets the paper-based structure of this thesis. Depending on the topic and the research question of each article, the multi-method research approach provides the necessary research flexibility. This DBA thesis discusses legal, technological as well as business administration topics. Thereby each article follows its own research method. The Database Article, the Marketing Article, and the Modality Mix Article are all qualitative research. The Survey Article follows a quantitative research method approach. The Concept Article has a combined quantitative-qualitative research approach.

On the other hand, it is argued that the a priori adoption of a single theoretical perspective could limit the scope of enquiry. One strategy suggested is that heterogeneous research perspectives be considered (Wolfe, 1994). Wolfe (1994) refers to research that recommends pooling different specialities in a multi-disciplinary effort using data from different research methodologies (Tornatzky & Fleischer, 1990); and he refers to research that argues that multi-disciplinary innovation research adds insight and depth exceeding those of any one perspective (Tushman & Nelson, 1990).

Given the multi-method research approach, this thesis is based on several data collection methods (Rasmussen, Oestergaard & Beckmann, 2006). Specifically, primary data are collected from interviews and a survey, whereas secondary data are collected from formal publications, such as books, research articles, newspaper articles, reports, and websites. An overview of the data collection in each of the five articles (see Part Two) follows.

5.2 Database Article

The Database Article examines the strategic location advantage for RFID databases in the EPCglobal Network in North America and Europe. The major research task is to interpret the applicability and protection of data within the EPCIS in these two different regions. To approach this task, *first*, the technological understanding of database technology and the EPCglobal network are explained. The data is collected from secondary data in formal publications and industry documentation available on the Internet.

Second, six court cases from the US Supreme Court, the Supreme Court of Canada, and the European Court of Justice are selected for the qualitative analysis: *Feist* (1991), *CCH* (2004), *Horseracing* (2004), *Fixtures Oy Veikkaus AB* (2004), *Fixtures Svenska Spel AB* (2004), and *Fixtures OPAP* (2004). These cases are landmark cases in the USA, Canada and Europe on the protection of databases based on the creativity doctrine, the skill and judgment doctrine, and the *sui generis* protection. The legal discussion in these decisions is based on copyright and *sui generis* protection regulation.

All secondary material data is analysed qualitatively.

5.3 Marketing Article

The Marketing Article analyses the legal and economic consequences of the RFID industry's marketing of short-range devices as active RFID tags. The data collection and analysis is threefold:

In a *first step*, a use case is provided based on an analysis of search and seizure cases in the USA (Dalal, 2006). Secondary data is collected based on the constitutional right of protection against unreasonable search and seizure, and from four Supreme Court cases. These cases give an overview of the US Supreme Court's change in policy and use of different technology from 1928 to 2001.

In a *second step*, a review of legal experts' understanding of technological innovation of RFID is conducted. A sample is selected from two leading legal information databases: Westlaw and LexisNexis. An extensive search is conducted for legal journal articles

on RFID. A gross sample of 141 legal journal articles, reviews and reports dating from 1997 to several months into 2007 is compiled. 98 articles are excluded because a full text analysis shows that neither their main nor their side content relates specifically to the technological innovation of RFID. A total of 43 legal journal articles are selected for this analysis.

In a *third step*, secondary data is collected and interpreted from vendors of short-range devices and RFID tags. This qualitative analysis is validated by primary data obtained at the Fourth Annual *RFID Journal Live! Europe* event in 2007, *the* key industry tradeshow for RFID vendors. The data was gathered (i) by observation and (ii) in personal informal discussions with the vendors.

5.4 Modality Mix Article

The Modality Mix Article provides a general reflection on how law must manage the evolution of technology, with the technological innovation of RFID as proxy. The data collection of this article is straightforward: the qualitative analysis of the Draft Recommendation (2008) is based on secondary data from both statutes and formal publications.

In a *first step*, the different modalities of regulation are briefly discussed (Lessig, 1999; Hübner-Fischer, 2000; Reding, 2006). In a *second step*, the Draft Recommendation (2008) is analysed article by article.

5.5 Survey Article

The Survey Article answers the question whether the legal regulators and the consumers have sufficient knowledge and support with regard to the adoption and diffusion of RFID technology, and how the technological innovators could support the improvement of trust in RFID technology. Empirical data is collected in a worldwide online survey with 111 participants⁷.

⁷ A commitment to publish only anonymous information was made to the survey participants.

In a *first step*, three in-person telephone interviews⁸ of approximately 45 to 60 minutes are conducted with RFID experts of Company A, Company B, and Company C. The in-depth interviews (Johnson, 2001) are semi-structured and conducted partly for exploration purposes, partly for testing the survey questions. They are transcribed and verified with the interview partners (see Appendix 3). Two further interviews had been planned and scheduled with Microsoft and Airbus. The interviewees of both firms cancelled the scheduled interviews on very short notice without any replacement date.

It is claimed here that no worldwide list of companies and organizations interested and involved in technological innovation of RFID, be it as suppliers, implementers, operators, or users exists. The current global population of companies and organizations interested in technological innovation of RFID is thus unknown. However, here it is argued that, with certain limitations, a representative list of companies and organizations engaged in technological innovation of RFID can be compiled. Whereas it is acknowledged that many online databases with companies and organisations engaged in technological innovation of RFID exist, it is maintained (i) that companies and organisations engaged in the emerging field of technological innovation of RFID will preferably participate in either the online platform of EPCglobal Inc. for standards or that of the RFID Journal for news; and (ii) that companies and organisations not participating in these two online platforms are likely not to be seriously engaged in technological innovation of RFID.

In a *second step*, a survey is submitted to 4'239 invitees in 224 countries. These 4'239 online contacts were compiled in a manual Internet search based on an initial list of 1'321 RFID-interested companies and organisations of EPCglobal and RFID Journal in the spring of 2008. The survey data returned are analysed quantitatively. The unit of analysis (Yin, 2003) is determined as company or organisation per country.

The questionnaire comprises 16 numbered questions on RFID and is divided into six main parts (see Appendix 4): parts 1 and 2 cover demographics; part 3 focuses on questions related to regulation by law; part 4 covers economy-related questions; part 5 covers

⁸ A commitment to publish only anonymous information was made to the interviewees.

consumer-related questions; and part 6 covers technology-related questions. The questionnaire mostly employs a 5-point Likert rating scale (Rea & Parker, 2005). It is suggested that for this worldwide survey on RFID a level of confidence of 95% with a 10% margin of error (Rea & Parker, 2005) provides sufficient accuracy (see Section 5.7).

The interview template, excerpts of the interview transcriptions, the survey questions, and the raw survey data are reproduced in Appendices 2 to 5.

5.6 Concept Article

The Concept Article researches how the three concepts of ubiquitous computing, pervasive computing, and ambient intelligence have evolved (or not evolved) through and in mass media. Secondary data is collected from 148 newspaper articles in 8 different newspapers in the USA, Canada and the UK. For such a survey, a researcher must determine, among others, source, parts, amount and period of data (Gunter, 2002).

In a first step, the *source* is determined. Eight newspapers are reviewed in detail to meet the selection criteria set by the author (English language, distinguished, conservative or liberal, dedicated technology section, and internationally available): the Times Online, the Financial Times London, the Guardian Unlimited, the New York Times, the Wall Street Journal Online, the Washington Post, the National Post (Canada), and the Toronto Star.

In a second step, the *parts* of the newspaper are selected. The Factiva database is searched for the Wall Street Journal and the LexisNexis database for the other seven newspapers. Both databases provide the online equivalent of the complete hardcopy version of the newspapers researched, but excluding pictures and graphs. Therefore it is justified to use these databases as data source for reviewing the necessary technology coverage of each newspaper.

In a third step, the *amount* is determined. 239 articles are retrieved from the two databases that meet the search criteria (“ubiquitous comput*”, “pervasive comput*” and “ambient intelligit*”). In total, 148 newspaper articles remained that contain at least one of the terms

researched. 91 articles were dismissed because they described relations not relevant for this research.

Finally, the research *period* is set. The articles are reviewed as far back as 1982. However, the first term appeared only in 1987. Newspapers have been reviewed for each full year until the end of 2006.

This secondary data is analysed both quantitatively and qualitatively. The results are then discussed in an informal interview with an expert researcher of the ambient intelligence community (primary data).

An excerpt of the coding sheet is reproduced in Appendix 1.

5.7 Caveat for the Interpretation of the Survey Data

As this thesis is of explorative nature, its data in general, but most importantly the quantitative data obtained in the Survey Article, need to be interpreted with caution.

5.7.1 Web-Based Survey

Among the many different types of surveys (Rea & Parker, 2005), Vogt (2007) notes that nowadays most quantitative analyses are done using computers. Hence, the survey conducted for this RFID research is in the so-called technological mode (Schaeffer & Presser, 2005). Web-based surveys have many advantages compared with mail-out or telephone surveys, such as cost-efficiency, speed, flexible response schedule, and negligible marginal costs for additional survey submissions. The disadvantages of a web-based survey are that it is limited to populations that have access to e-mail and computers and thus also requires computer literacy. Furthermore the advantages enumerated here can work against web-based surveys: since the logistics of e-mail and web-based surveys are cheap(er), there is a flood of surveys submitted by researchers (not ruling out the author of this thesis). There is also a self-selection bias (Heckman, 1979) that leads to lower response rates, for instance, due to language problems.

5.7.2 Threats to Validity

According to Vogt (2007) and Schaeffer & Presser (2007) there are certain threats to validity in research that must be taken into consideration, such as:

1. Self-selection effects: Subjects are not randomly assigned to the interest groups of the researcher. They assign themselves and do not do so randomly. For instance, some members can choose not to respond.
2. Attrition effects: Also often called mortality, attrition can occur when subjects drop out of a study. It is another form of self-selection effect, but involves self-selecting out, not in.
3. Volunteer effects: People who consent to being studied can often differ in important ways from those who do not consent to being studied.
4. Interpretation effects: Respondents “construct a ‘pragmatic meaning’” that can include their interpretation, the reason a question is being asked, and what an acceptable answer would be when they hear or read a survey question.

Hence, in a survey a proportion of the sample will not be traceable, will be refused by the respondent, or will return incomplete and unusable questionnaires. This would be irrelevant if the lost respondents were themselves a random sample, but this is very unlikely (Sapsford, 2007).

For this thesis, *first*, the population of companies and organisations engaged in RFID technology is unknown which is why the two databases of EPCglobal and RFID Journal are used to compile a population. It is maintained that authoritative companies and organisations engaging in the emerging field of RFID will subscribe to at least one of the two databases.

Second, the survey is sent to the entire population, leaving the respondents a certain self-bias to reply. There are numerous out of the office replies as well as direct replies by the respondents stating (mostly) that participation in any kind of survey violated their corporate communication policies. No assessment is done as to why many survey invitees did not answer the survey (or why the invitees that did answer, answered).

Third, a few webpages in Eastern Europe and Asia Pacific do not provide any English webpage translation and the appropriate e-mail contact cannot be found. These companies and institutions are considered out of scope (population) and are not contacted.

Fourth, a few webpages provide no online contact, i.e., neither e-mail nor webforms. These companies and institutions are considered out of scope (population) and are not contacted.

Finally, the statistical analysis of the data in this survey is conducted under the two assumptions that (i) the sample is fully unbiased; and (ii) the distribution is normal according to the commonly understood bell-shaped curve (Rea & Parker, 2005).

Despite these possible sources of error it is suggested that the analysis of the survey data by the respondents is a reasonable method for conducting the research for this thesis. Schaeffer & Presser (2005) note that the researcher must determine the level of accuracy he or she will try to achieve with the analytical goals and resources at hand.

5.7.3 Non-Probability and Non-Response

A key question of survey sampling is how large the research sample should be (Vogt, 2007). Whereas, for example, Nardi (2003) supports large sample sizes as being more accurate, Couper (2000) advocates that in Internet research other rules might apply. He argues that the Internet population is different from the general population in several respects (accessibility, speed, cost, etc.). Couper (2000) seems to contradict Vogt (2007) in that he states that there is a misguided assumption that in web-based surveys large samples necessarily mean more valid responses. However, taking a self-critical stance, one must regard the relative response rate of 4.36% (185 replies from 4'329 submitted and received survey invitations) as insufficient; even by Couper's (2000) standard. There is clearly a large non-response bias (Vogt, 2007). This makes a generalization about the target populations quite suspect. Clearly, a larger response rate would have been desirable and more favourable to the result in this thesis.

Similarly to Nardi (2003), Rea & Parker (2005), and Vogt (2007), Couper (2000) differentiates between non-probability methods and probability-based methods for web surveys. The former method

includes polls as entertainment, unrestricted self-selected surveys, and volunteer opt-in panels. The latter method includes intercept surveys, *list-based samples*, web options in mixed-mode surveys, pre-recruited panels of Internet users, and pre-recruited panels of full population. Here the list-based method is of particular interest. A list-based sample for web surveys is a sample that has either a frame or a list of those units with Internet access. In casu this is the list of e-mail addresses and web contact forms compiled.

Furthermore, non-probability sampling means that not every element has the same chance of being selected for the study (Nardi, 2003; Rea & Parker, 2005; Vogt, 2007). In non-probability, sampling the researcher does not know the probability that a particular respondent will be selected as part of the sample. There is no certainty that the probability of selection is equal among the potential respondents. Without such equality, an analysis of the sample in the context of the normal distribution is not possible. It is only possible to make general conclusion about those who have *completed the survey*. A generalization beyond the respondents is *not* possible.

5.7.4 Level of Confidence and Error Margin

At any rate, in case the 111 responses *were* a random sample, here is what the level of statistical significance would be:

The correct sample size depends mostly on the tolerance for uncertainty and how high a risk of drawing a false conclusion one is willing to incur. Ultimately one needs to decide whether the risk or error is worth accepting (Vogt, 2007). Two interrelated factors must be addressed before proceeding with the selection of the sample size: level of confidence and confidence interval to which the finding must conform (Rea & Parker, 2005). A typical level of confidence is normally either 95% (i.e., 5% risk of error) or 99% (1% risk of error). The sampling accuracy indicated as error margin is typically set at 10%, 5% or 3%.

For small populations, i.e., below 100'000 (Rea & Parker, 2005), the equation to determine the sample size n is:

$$n = \left(\frac{Z_a \sqrt{p(1-p)}}{ME_p} \sqrt{\frac{N-n}{N-1}} \right)^2 = \frac{Z_a^2 (p(1-p))N}{(Z_a^2 (p(1-p))) + ((N-1)ME_p^2)} \quad \begin{array}{l} \text{Equation 1:} \\ \text{Sample size} \end{array}$$

where:

n = *sample size*;

N = *population size*;

Z_a = *score for level of confidence (i.e. 1.96 or 2.575, see below)*;

p = *population proportion (i.e. 0.5, see below)*;

ME_p = *margin of error*.

According to Rea & Parker (2005), the most conservative way of handling the uncertainty of setting a sample size is to set the value of population proportion p at the proportion that would result in a higher sample size. This occurs when p is set at 0.5. The scores for the two levels of confidence are set at 1.96 for a 95% level of confidence and 2.575 for a 99% level of confidence (Rea & Parker, 2005).

By the survey deadline of July 30, 2008 at 11.59pm CET 185 recipients of the 4'239 survey invitations delivered had responded. Of these 185 responses, 58 were returned blank; 11 respondents answered the questionnaire partially; and 100 respondents completed the questionnaire. For the remainder of this paper, only the 111 full and partial survey replies are considered relevant.

Total surveys invitations submitted	4'963
Out of office replies (delivered message)	224
Postmaster failure (undeliverable messages)	512
Spam filtering failures (undeliverable messages)	12
Opt out e-mails for surveys by Surveymonkey (undeliverable messages)	200
Total undeliverable messages	724
Total submitted and received surveys invitations	4'239
Full replies	100
Partial replies	11
Total replies (full and partial)	111

Table 14: Summary of survey invitations and replies.

Before conducting the survey, the actual sample size n of the returned surveys is unknown. But in order to set the threshold for statistical analysis, the minimum sample size n needs to be identified. To solve this predicament, the level of confidence is fixed at a certain percentage and in a first step the error margin is estimated. It is suggested that for this worldwide survey on RFID a level of confidence of 95% with a 10% margin of error provide for sufficient accuracy. According to Equation 1 and the data in Table 14, the equation for the sample size n is:

$$n = \frac{1.96^2(0.5(1-0.5))4239}{(1.96^2(0.5(1-0.5)))+(4239-1)0.1^2} = 93.93 \quad \text{Equation 2: Sample size}$$

Hence, the minimum sample size n is 94 replies. As stated above, the survey returned 100 full and 11 partial replies. Both, the full and the total replies each individually, exceed the minimum sample size of 94 units. After having conducted the survey and after having received

100 full and 11 partial replies, the exact error margin ME_p can be computed in a second step from the Equation 1:

$$ME_p = \sqrt{\frac{\left(Z_a^2(p(1-p)) \left(\frac{N}{n} \right) \right) - \left(Z_a^2(p(1-p)) \right)}{N-1}} = 0.0968$$

Equation 3:
Margin of
error

The conservative calculation approach includes only the 100 full replies in the computation. It does not include the partial replies. This will ensure that, if and when the partial replies are included, the error margin will become smaller, not larger. This approach is favourable for accuracy purposes.

For the Survey Article the quantitative data can therefore be analysed with a 95% level of confidence at an error margin of 9.68%. This is insignificantly lower than the estimated margin of error of 10% for Equation 2. The margin of error of 9.68% is an upper bound computed. It does not include the partial replies. If the partial replies are added to the sample size n , then the error margin will become smaller, not larger (see Equation 3).

5.8 Chapter Summary

Chapter 5 outlines the qualitative and quantitative data collection of this thesis. Based on a multi-method approach, it draws empirical data, which will lead to the observations in the subsequent Chapter 6 from interviews, discussions with experts, an observation, a survey, statutes, adjudication, publications, and industry documentation. Certain caveats are proposed, especially in the interpretation of the data of the Survey Article. Threats to validity are discussed. The non-probability sample and the non-response bias should caution the reader: It is recommended not to generalise from the results but rather to treat the conclusions as interesting hypotheses that can serve as starting point for future research.

Table 15 summarises the data collection method and analysis method of the individual articles of this thesis. For each article the research method is divided into data collection and analysis. A “✓” indicates the placement of data collection methods or analyses in the five research articles.

Research Method Article	Data Collection							Analysis	
	Primary source				Secondary source			Qualitative	Quantitative
	Interview with expert	Discussion with expert	Observation	Survey	Regulation by law	Court decision	Formal publication		
1. Database					✓	✓	✓	✓	
2. Marketing		✓	✓		✓	✓	✓	✓	
3. Modality Mix		✓			✓		✓	✓	
4. Survey	✓			✓	✓		✓	✓	✓
5. Concept	✓						✓	✓	✓

Table 15: Summary of the research methods of the individual articles.

Chapter 6

Observations

Chapter 6 stipulates four observations as first premise of abduction. It summarises the findings of four of the five academic articles that comprise the findings of this thesis: The Database Article compares the legal database regulation within the territorial and jurisdictional scope of this thesis, i.e., North America and Europe (Section 6.1); the Marketing Article analyses the marketing behaviour of RFID suppliers (Section 6.2); the Modality Mix Article proposes a modality mix as regulation structure for the adoption and diffusion of RFID (Section 6.3); and the Survey Article evaluates the RFID industry's perception of the legal regulator and the consumers (Section 6.4).

Each of these four articles is discussed in this chapter in terms of research question, framework and observation. Each article stipulates one observation as first premise within abductive reasoning.

6.1 Observation 1: Database Article

6.1.1 Research Question

EPCglobal Inc., an initiative of the Uniform Code Council, Inc. and the EAN International (GS1), is leading the development of industry-driven standards for the deployment of electronic product codes (EPC) in RFIDs. The decisions of database locations for businesses operating at the international level could be of strategic importance, because, firstly, the access linked to the EPC stored in an RFID is leveraged through the Internet by using the EPCglobal Network, and, secondly, the protection of databases is treated differently in the USA, in Canada, and in the European Union from a legal viewpoint.

The purpose of this article is to analyse the EPCglobal Network Architecture Framework in light of the landmark decisions on copyright and database protection in the USA (*Feist*, 1991), Canada (*CCH*, 2004), and the European Union (*Horseracing*, 2004; *Fixtures OPAP*, 2004; *Fixtures Oy Veikkaus AB*, 2004; *Fixtures Marketing Svenska*

Spel AB, 2004). Is there is any strategic advantage of placing the RFID databases in any of these three jurisdictions?

6.1.2 Framework

The framework of the Database Article comprises two components. On the one hand, it covers technological innovation of databases. Here, the relational database model as proposed by Codd (1970; 1990) is used. Each table in a relational database consists of rows (tuples) and columns (attributes), whereby the order of tuples is irrelevant. The relation is an unordered set and the data can be entered in any sequence.

On the other hand, the framework covers regulation by law. Here the landmark cases of the US and Canadian Supreme Courts and the European Court of Justice (ECJ) on copyright and database protection are interpreted. These cases are analysed based on the relational database model. RFID databases located in the USA are analysed based on the US copyright law and the creativity doctrine, i.e., originality in selection and arrangement. RFID databases located in Canada are analysed based on Canadian copyright law and the skill and judgement doctrine. Finally, RFID databases located in Europe are analysed based on the *sui generis* Database Directive (96/9/EC) and the investment doctrine.

6.1.3 Observation

It seems difficult to dispute that the information about an RFID-tagged object as well as the EPC in the RFID tag are pure facts. The analysis of the data compiled into an RFID database yields the following results in the three delimited jurisdictions covered in this thesis, i.e., USA, Canada and Europe:

First, in the USA, under the creativity doctrine, the arrangement would be relevant for the classification of originality. But the *arrangement* of the tuples in the database is irrelevant. Hence, there is no arrangement in the database. This leads to the analysis of *selection*, the second attribute to meet the *sine qua non* of copyright law, i.e., originality. The selection of the object information does not seem to require much creativity either: (i) the data to be compiled in the database will most probably be given by the information that is to be

conveyed about such object. The creativity is attached to, e.g., the composition or production method of the object, and not to the selection of its (subsequent) attributes; and (ii) if the attributes about an object are not automatically given by the object itself but by the compiler's discretion, then the selection is nonetheless likely to be non-creative because each object will be described by the same attributes. RFID data is not protected under the creativity doctrine.

Second, in Canada, under the skill and judgement doctrine, there is no protection in an individual component, but there can be copyright protection in the overall arrangement. The question is whether there is skill and judgement in the selection and arrangement. Here also, the *arrangement* of the tuples in the database is irrelevant. Hence, there is no arrangement in the database. As for the *selection* under Canadian case law, the skill and judgement it takes to select the information about an object, let alone the information in the RFID tag, are trivial. RFID data is not protected under the skill and judgement doctrine.

Third, in Europe, under the investment doctrine, three clarifications to the interpretation of the *sui generis* Database Directive (Directive 96/9/EC) are made for obtaining, verifying and presenting of data: (i) obtaining data refers to the resources used to seek and collect information in the database and not to the resources used for the creation; (ii) consequently, verifying data does not refer to the resources used in creating the database either; and (iii) the investment in presenting relates to the systematic and methodical arrangement of the material contained in the database. RFID data is not protected under the investment doctrine.

In summary, the compilation of RFID-based data in databases lacks either creativity (USA), or requires neither skill nor judgement (Canada), or does not qualify as creation of a database (Europe). Therefore no strategic advantage of placing an RFID database in any of the three regions is given from a perspective of regulation by database law. The heterogeneous examples and the geographical scope of RFID adoption and diffusion lead to the following observation:

Observation 1: *Despite the amount of data anticipated to be stored and the regulation by law in the different countries where RFID is adopted and diffused, the location of the databases containing RFID data does not seem to play an important role for the technological innovator.*

6.2 Observation 2: Marketing Article

6.2.1 Research Question

This article analyses the legal perception and marketing practice of so-called *active* RFID tags. The RFID industry includes short-range transmitters in the product line of RFID to benefit from the RFID wave of success and to increase sales. The legal consequences of merging the functionalities of both active RFID tags and short-range devices might lead to a restrictive legal interpretation and understanding of RFID because the technological features of short-range devices are broader than those of RFID.

This research therefore answers the question why marketing short-range devices as active RFID as understood by Bensky (2004), Finkenzeller (2006), and Kern (2006) might backfire on the RFID industry.

6.2.2 Framework

The framework of the Marketing Article has two pillars. On the one hand, it covers diffusion of technological innovation. The theory of active RFID tags and of short-range devices is presented. Whereas Bensky (2004), Finkenzeller (2006), and Kern (2006) differentiate active RFID tags from short-range devices, Glover & Bhatt (2006), EPCglobal Inc., and RFID Journal define short-range devices as active RFID tags. This leads to a differentiated adoption and diffusion of these technological innovations by the industry. Certain suppliers of RFID tags market their short-range devices as active RFID tags.

On the other hand, the framework covers regulation by law. A use case is presented based on four landmark US Supreme Court cases

(Dalal, 2006). These cases adjudicate on search and seizure of evidence collected (i) by wiretapping (*Olmstead*, 1928), (ii) from a public telephone booth (*Katz*, 1967), (iii) from a beeper (*Knotts*, 1983), and (iv) by thermal heat surveillance (*Kyllo*, 2001). The regulation framework is limited to case law in North America because, except for Synometrix Integrated Technologies (2008) that is based in Taiwan, all other industry players identified in the following sub-section are headquartered in North America. Some of these companies are globally active.

6.2.3 Observation

Following the framework, the results of the Marketing Article are split into a regulation and a technological innovation outcome. *First*, the analysis of 43 legal journal articles shows that fifty percent of the scholars differentiate the RFID tag type. Of those that differentiate the tag type, Landau (2006) and Smith (2006) follow the theory of active RFID tags proposed by Bensky (2004), Finkenzeller (2006), and Kern (2006). Stark & Nagle (2004), Delaney (2005), Terry (2005), Eschet (2005), Asamoah (2006), Herbert (2006), Smith (2007), Eden (2005), Stein (2007), Willingham (2007), Handler (2005), and Koops & Leenes (2005) refer to battery-supplied RFID tags, which corresponds to the definition of Bensky (2004), Finkenzeller (2006), and Kern (2006) of a short-range device, or to Glover & Bhatt's (2006) understanding of an active RFID tag. Finally, Brito (2004), Thompson, Kot & Brothers (2005), Eng (2005), Kobelev (2005), and Eleftheriou, Berliri & Coraggio (2006) remain unclear in their statements about the technology of the RFID tags they refer to.

Second, in line with Glover & Bhatt (2006), but contrary to Bensky (2004), Finkenzeller (2006), and Kern (2006), the analysis of selected suppliers of RFID systems (Auto Access ID, 2007; AeroScout Inc., 2008; Axxess Inc., 2008; Multispectral Solutions Inc., 2008; RF Code Inc., 2008; RFID Inc., 2008; RFind, 2008; Savi Technology Inc., 2008; Synometrix Integrated Technologies, 2008; Ubisense Ltd., 2008; Wherenet, 2008) shows that *short-range devices* are marketed as *active* RFID tags. Eight suppliers refer explicitly to the marketed tag as "active tag" (or similar), while all eleven datasheets include the feature of self-dynamic signal transmission to the reader, i.e., these tags beacon or blink periodically.

This means that the suppliers reviewed are marketing their short-range transmitters as active RFID tags. Conversely, the legal community does not differentiate accurately between the different tag functionalities. This means that the legal community includes the self-dynamic functionalities of short-range transmitters in their understanding and analysis of RFID. Hence, the claim can be made that if the RFID industry keeps marketing its short-range transmitters as RFID, the legal community might continue including such broad and self-dynamic device functionalities in its legal interpretation and analysis of RFID. The inclusion of broad short-range device functionalities by the legal community in its interpretation, policy, and decision making might lead to restrictive interpretation, use, and limited legal acceptance of RFID. Why? Because as the use cases show, if monitoring a beeper in the USA that broadcasts its signals in public is not unconstitutional under the Fourth Amendment, and the legal community perceives short-range devices and RFID to be the same technology because of the marketing endeavours of the industry, then legal regulators (e.g., privacy advocates) might join forces to legally stop the implementation and deployment of RFID in order not to run the risk of having constitutional surveillance of RFID tags as defined by Bensky (2004), Finkenzeller (2006), and Kern (2006) without a warrant. The marketing strategy of exploiting the success of RFID might backfire on the RFID industry as the industry would need to follow (more) restrictive law and case decisions.

As argued above, interpreting the technical innovation of short-range devices as active RFID tags might become unfavourable to the industry because applying the current adjudication of *Knotts* (1983) might lead to more stringent regulation by law. The discussion regarding the energy supply and coupling leads to the following observation:

Observation 2: *Extending the doctrinal definition of active RFID tags to include reader-independent and indiscriminate signalling might lead to unfavourable regulation by law.*

6.3 Observation 3: Modality Mix Article

6.3.1 Research Question

In 2006 the European Commission conducted several workshops and a public consultation process on RFID (____, 17. January 2007). The European Commission noted that despite most stakeholders still being unaware of the potential and risk of RFID, opposing camps had already formed (Van de Voort, Maarten & Ligtoet, 2006). These opposing camps were confirmed in an interview with an industry stakeholder:

“[...] the privacy debate specifically focused on the end result of an RFID enabled world, basically. And tries to emphasize what could be done as if this could be done already today, leading to a situation where you have, on the one hand, pressure groups [...] who singled out RFID as very heavily threatening technology for privacy and data protection. And regulators who came in to look at this issue [...] and had practically two choices to inform themselves: one were those *pressure groups* and the others were *businesses* who were still in very early experimental phases of RFID and could not say much or could only talk about the end vision. [...] And so it somehow flawed impression of what is possible if RFID developed, among non-technical people, lawyers and regulators. [This leads] to a situation where now [...] perceived threats are actually what we are talking about. And perceived threats are what regulators actually try to address in their regulation. Not real threats.” (Interview with Company B)

In February 2008, the European Commission issued the Draft Recommendation (2008) on RFID. However, law alone can neither enable nor guarantee legal values (Lessig, 1999). Given the way the Draft Recommendation (2008) is structured, it is possible that from a holistic perspective the technological innovation is over-regulated. The research question is therefore how a trade-off between different

modalities of regulation can take place based on the Draft Recommendation (2008).

6.3.2 Framework

The framework of the Modality Mix Article is based on the regulation by the four modalities law, norms, market, and architecture (Lessig, 1999); see also Section 3.2.2:

Law typically regulates behaviour by statutes. Law is regulated, controlled and enforced by government authorities. Mostly there will be a constitutional mandate to enact statutes. The statutes can envision further delegation to ordinances or rules. The European Commission, for example, has enacted directives that need to be implemented into national law of the EU member states.

Norms are non-legal rules that certain individuals feel compelled to follow despite the lack of formal legal sanctions. Or put positively, they are non-legal rules that certain individuals follow because they benefit from doing so (Carlson, 2001). Both modalities, law and norms, threaten punishment *ex post*. But whereas the regulation by law is centralised at authority level, the regulation by norms is decentralised by and to a community (Lessig, 1999). As noted in Section 4.3 and Table 11, there is a grey zone between law in the narrow sense and law in the wide sense. The term “norm” as used in the Modality Mix Article is to be understood as law in the wide sense.

Market regulates behaviour by different influences, such as demand and supply that is reflected in price. Prices can constrain access. Lower RFID tag costs and improved RFID tag performance have opened new markets and applications for RFID (Van de Voort, Maarten & Ligtoet, 2006).

Architecture also regulates in the form of shaping one’s behaviour. Here it is argued that RFID architecture is divided into physics and systems (artefacts): On the one hand, the RFID architecture has specific characteristics by radio waves that direct and limit the way RFID technology can be implemented and used (e.g., water or metal) (Sood, 2007). On the other hand, the RFID architecture includes the structure of IT systems (multi-tier RFID system) (Lahiri, 2006).

6.3.3 Observation

It is argued here that in the RFID space (as also in many other fields), polarizing solutions will generally not be favourable. A balance should be found. Whereas the understanding of RFID technology by legal experts is not always beyond doubt (Ronzani, 2008b), generally arguing for multidisciplinary dilettantism in research of law and technology (Easterbrook, 1996) is exaggerated. A differentiated approach seems justified.

The various legal recommendations proposed by the Draft Recommendation (2008) do not provide precise supplementing legislation as suggested by (Easterbrook, 1996). It is advocated here that technology-independent regulation by law should not be complicated and diluted by recommendations that address the same issues. There do not seem to be any additional benefits in the Draft Recommendation (2008) for RFID users and stakeholders compared with the already existing directives, such as the Data Protection Directive (95/46/EC) or the Database Directive (96/9/EC). The proposals in the Draft Recommendation (2008) are largely redundant with existing mandatory regulation by law. Issuance of yet another recommendation would be over-regulating and is not to be favoured.

Instead, it is suggested in the Modality Mix Article that the topics of the Draft Recommendation (2008) are likely to be more successful if shifted towards one of the other three modalities. Table 16 summarises the analysis of the proposed topics of the Draft Recommendation (2008).

The topics of the Draft Recommendation (2008) are listed in the vertical, the proposed modalities or regulation in the horizontal direction. Filled squares (■) indicate where the regulation is proposed. The entire Draft Recommendation (2008) itself is a modality of regulation by law, which is why the entire law column is tagged. Circles (○) indicate in which modality of regulation a topic proposed in the Draft Recommendation (2008) on RFID might be more successfully regulated. Topics that either are not addressed or should not be addressed in the Draft Recommendation (2008) are flagged with a dash (-).

Draft Recommendation (2008)		Modalities			
Sections in Draft Recommendation	Selection of Topics in Draft Recommendation	Law	Norms	Market	Architecture
Scope	Law	■ ○			
	Ethics	■	○		
	Society and politics	■	○		
	Economy	-		○	
Definitions	RFID application	■			○
	RFID application operator	■		○	
	Tag	■			○
	Reader	■			○
	Deactivation	■			○
Privacy Measures	Risk assessment	■ -			
	Burden of proof	■ ○			
	Publication	■	○		
Code of Conduct	Specific codes of conduct	■	○		
Information on RFID Use	Public places	■	○		
Information Security Risk Management	State-of-the-art information security management	■			○
	Application-specific guidelines	■	○		
	Coherent internal market approach	■		○	
Retail	Signs	■	○		
	Legitimate after-sale	■		○	
	Opt-in / opt-out	■	○		
	Deactivation requirement	■	○		
Awareness Raising	Companies and SMEs	■	○		
	Government and general public	-	○		
	Good practices in RFID application implementation	■	○		

Table 16: Matrix proposal for the distribution of regulation by law to other modalities of regulation.

The conclusion is that net regulation (Lessig, 1999) and trade-off are encouraged. It is viable to reduce the regulation by law by *not* implementing the Draft Recommendation (2008) of RFID by the European Commission. The current mix of modalities of regulation is inappropriate for the adoption and diffusion of RFID as technological innovation.

The characteristics of regulation lead to the following observation:

Observation 3: *The current adoption and diffusion of RFID technology do not seem to be following an appropriate mix of regulation.*

6.4 Observation 4: Survey Article

6.4.1 Research Question

This article researches the RFID industry's perspective of the adoption and diffusion of RFID technology with regard to regulation and consumers. It adds to the discussion on consumer opinions of RFID adoption and diffusion by providing empirical data collected in a worldwide online survey on the RFID industry's view of regulation and its view of consumers. It answers the question whether the legal regulator and the consumers have sufficient knowledge and support with regard to the adoption and diffusion of RFID technology, and how the technological innovator could support the improvement of trust in RFID technology.

6.4.2 Framework

In the past few years, there have been several articles presenting data on RFID, for instance, by Strickland & Hunt (2005) regarding the fear and lack of knowledge of information-collecting technologies, by the Commission of the European Communities (2006) showing the insufficiency of available information to form an opinion about RFID technologies, by Angeles (2007) on the willingness to purchase RFID-tagged products, or by Rothensee & Spiekermann (2008) on privacy awareness and acceptance of service. This article presents the industry perspective based on empirical data.

The framework of the Survey Article comprises two aspects. On the one hand, the framework covers the technological innovator's perception of certain tools of regulation by law (frequency regulation, database regulation, privacy regulation) and the assessment of the expertise of the legal regulator (legislator, lawyers and judges). On the

other hand, it covers the technological innovator's perception of consumer awareness and knowledge of RFID.

6.4.3 Observation

Based on the survey results, one could come to the conclusion that it is the regulator's and consumers' fault when issues with RFID arise. After all, according to the respondents of this survey – on a black and white scale – the regulator has no clue about RFID technology and the consumers are badly informed about RFID technology.

However, here it is concluded that to a certain degree also the RFID industry is at fault. *First*, the RFID industry tends to favour not engaging legal experts in RFID issues over engaging such legal (non-) experts. However, how is the legal regulator supposed to learn about and improve its knowledge of the RFID technology if there is no constructive dialogue?

Second, on the one hand, the RFID industry does not trust the RFID expertise of the regulator; on the other hand, it is itself not completely aware of important regulations pertaining to RFID. How is the legal regulator supposed to promote a technology and rule out, for instance, uncertainties and distrust in the technology if not all legal tools are understood and utilised to the innovator's advantage?

Third, the RFID industry believes consumers are, in general, very badly informed about RFID technology. However, despite the apparently good self-evaluation of the RFID industry's information policy, the consumers remain badly informed. Either the counter-information provided by consumer organisations and the regulator is much better, or the RFID industry's information policy is not yet where it should and could be to promote RFID technology to its advantage.

The professional exchange between the RFID industry and both legal regulator and the consumers is insufficient. This shows, on the one hand, that legal regulation takes a back seat in the exchange with the industry; on the other hand, the review shows that customers need to be better integrated into the process of adoption and diffusion of technological innovation. Thus a fourth and last observation can be formulated:

Observation 4: *The interaction between, and consequently also the exchange of expert know-how and standpoints of, (i) the RFID industry and the legal regulator and (ii) the RFID industry and the consumers seem insufficient.*

6.5 Chapter Summary

Chapter 6 summarises the *individual findings* of four of the research articles reprinted in Part Two. Table 17 summarises the four observations:

Observation		Article
O 1	Despite the amount of data anticipated to be stored and the regulation by law in the different countries where RFID is adopted and diffused, the location of the databases containing RFID data does not seem to play an important role for the technological innovator.	Database Article
O 2	Extending the doctrinal definition of active RFID to include reader-independent and indiscriminate signalling might lead to unfavourable regulation by law.	Marketing Article
O 3	The current adoption and diffusion of RFID technology do not seem to be following an appropriate mix of regulation.	Modality Mix Article
O 4	The interactions between, and consequently also the exchange of expert know-how and standpoints of, (i) the RFID industry and the legal regulator and (ii) the RFID industry and the consumers seem insufficient.	Survey Article

Table 17: Summary of observations.

The Database Article proposes that, from a regulation by law perspective, there does not seem to be a strategic advantage to place RFID databases in either Europe or North America. The Marketing Article argues that the industry's efforts to diffuse short-range devices as active RFID tags might, from a regulation by law perspective, be counterproductive in the long run. The Modality Mix Article concludes that the focus of regulating RFID technology should probably shift from regulation by law to other means of regulation, such as social

norms, market and architecture. Finally, the Survey Article concludes that the RFID industry should probably communicate better with the legal regulator and the consumers to foster the adoption and diffusion of RFID technology.

Chapter 7

Discussion

Chapter 7 stipulates the two hypothetical claims of abductive reasoning. In Section 7.1, an IS research literature review on the adoption and diffusion characteristics of technological innovation in IS research, viz. IT, EDI, and RFID, is presented. Based on this review and the definitional framework of Chapter 3, the two hypothetical claims are suggested (Sections 7.2 and 7.3).

7.1 Characteristics of Technological Innovation in IS Research

Research in the area of adoption and diffusion of technological innovation has resulted in several theoretical models with roots in psychology, sociology, and IS (Venkatesh, Morris, Davis, & Davis, 2003) (see Section 3.1). A literature review with a systematic approach seems appropriate to analyse the inclusion of regulation as characteristic in the use of innovation theories. Three areas are reviewed, moving from a general viewpoint to the specific topic of this thesis: IT (Section 7.1.1), electronic data interchange (EDI) (Section 7.1.2), and RFID (Section 7.1.3). Starting point for this review is the extensive literature compiled by Schmitt (2008), who focused on other than regulatory clusters and characteristics. It is therefore appropriate to use Schmitt's (2008) review to analyse that body of literature from a regulatory perspective.

Schmitt (2008) based his literature review on a database research on EBSCOhost, ScienceDirect, ProQuest, AISel and IEEE, among others, sub verbo "RFID", "IT", and "EDI", each also combined with the terms "adoption" and "diffusion". Certain journal articles from, e.g., IEEE and Blackwell, have been omitted herein for lack of (DB) license rights. Each of the 45 articles retrieved has been read carefully and analysed with regard to the characteristics of adoption and diffusion of their underlying technologies and regulation. In the following sub-sections a detailed summary of these characteristics is provided. A

complete list of the 329 characteristics distributed among the 45 articles reviewed is presented in Appendix 6.

7.1.1 Characteristics Used in IT Research

Papastathopoulou, Avlonitis, & Panagopoulos (2007) examine the implementation of ICT tools in marketing-related and non-marketing-related functions. They posit that characteristics contributing to the successful intra-organisational diffusion of information and communication products are critical. They divide the characteristics contributing to diffusion success into ICT characteristics (relative advantage, compatibility, cost, security), organisational characteristics (formalisation, commitment to change), and market characteristics (demand uncertainty, intensity of competition). At first sight, of these different characteristics, security seems to relate to regulation by law. However, a closer review of the way it is used reveals that regulation by law is only (indirectly) assumed.

Lee & Xia (2006) explain past mixed and inconsistent results in empirical studies with organisational size as predictor of IT innovation adoption. Their review of IT innovation adoption research suggests that organisational size (entity or department) is one of the most commonly studied determinants of IT innovation adoption. Within organisational size as characteristic they examine six moderators (type of innovation, industry sector, type of organisation, stage of adoption, scope of size, type of size measure). Their conclusion is that direction and strength of the relationship between organisational size and IT innovation adoption depend on type of innovation, type of adoption organisation, adoption stage, scope of size measure, and type of size measure, whereas industry sector is not a significant characteristics.

Lai, Ngai, & Cheng (2005) report on the current state of IT innovation adoption in the logistics industry. Examples of such IT applications are, for instance, warehouse management, intranet, barcode, RFID, and ERP. Their characteristics for the implementation of IT in logistics are perceived benefits and perceived barriers.

Craighead & Laforge (2003) explore the adoption of IT by manufacturing firms. Their study focuses not only on one type of IT innovation but rather on several applications of a firm or organisation.

They focus on application positions within manufacturing firms rather than on specific systems or technologies. The IT adoption characteristics relate to plant size, predominant manufacturing approach and process, extent of use of IT applications, integration of IT applications, manufacturing performance, and overall performance.

Carter, Jambulingam, Gupta, & Melone (2001) study, among others, the factors that affect adoption (and implementation) of IT innovations by the industry, such as software cost models or programme design language. They focus on characteristics, such as advocacy for IT innovation (middle management, technical staff, top management), relative advantage, compatibility, perceived complexity, and communication.

Chen & Fu (2001) deal with IT adoption in manufacturing industries. Their research provides a model to specifically describe the IT adoption process in manufacturing fields in terms of market and production technology change. With regard to the adoption of IT, they focus on the characteristics of market pattern, firm size, innovation capacity, and economic performance.

Premkumar & Roberts (1999) study the state of use of various communication technologies and factors that influence the adoption of such technologies in small businesses in rural communities. They measure communication technologies, such as facsimile, e-mail, online access, and EDI. To do so they, divide the characteristics into three main groups: (i) innovation characteristics (relative advantage, cost, complexity, compatibility); (ii) organisational characteristics (top management support, IT expertise, size); and (iii) environmental characteristics (competitive pressure, vertical linkage, external support). Note that in their study, the external support refers, for instance, to outsourcing; not to regulation (by law).

Thong, Yap, & Raman (1996) study the relative importance of top management support and external IS expertise, and conclude that the former is not as important as the latter. Whereas top management support is essential for the effectiveness of IS, high-quality external IS expertise is more critical for small businesses. The characteristics used in their conceptual model of that research are top management support and external IS expertise (effectiveness and quality).

Swanson (1994) posits that there are three types of innovations in IS: those that are confined to the IS task itself, those that support business administration, and those that are imbedded in the core technology of the business. In that study five characteristics for the adoption and diffusion of IS innovations are researched: organisation/unit size, diversity, free capacity (slack resources), application system portfolio, and professional orientation of the IS team.

Grover & Goslar (1993) approach the use of telecommunication technologies from an innovation perspective. Their research model consists of three characteristics groups: (i) environmental characteristics (uncertainty, heterogeneity); (ii) structural characteristics (size, centralisation, formalisation, specialisation); and (iii) IS characteristics (top management knowledge and involvement).

Attewell (1992) develops an alternative model that emphasises the role of know-how and organisational learning as potential barriers to adoption of innovations. To examine the diffusion of complex production technologies, he investigates knowledge and technical know-how, complexity (of software) and demands (placed on hardware) as well as the cost.

7.1.2 Characteristics Used in EDI Research

Seyal, Rahman, & Mohammad (2007) examine and explore the determining factors that contribute to EDI adoption among Brunei's small and medium enterprises. The different factors influencing EDI adoption are organisational, environmental, and technological. The first group includes the characteristics organisational culture, top management support, and motivation to use EDI. The second group includes government support as characteristic. Finally, perceived benefits and task variety are the technological characteristics.

Kartiwi (2006) aims at understanding the factors and combinations of factors that small and medium enterprises need to consider before embracing e-commerce in their business. Relevant characteristics of adoption are business strategy, careful planning and justification, customer readiness, and external support (owing to lack of inhouse expertise).

Agi, Ballot, & Molet (2005) study the opportunities of success of a “100% EDI-connected suppliers” policy using data from the vehicle industry. They identify three groups of factors affecting EDI adoption by organisations: organisational readiness and familiarity with IT, which is further subdivided into size of supplier and use of system; customer power and supplier dependence; and expected benefits from EDI use.

Tanewski, Collier, & Leech (2003) propose a model of strategic alignment tested in multiple case studies in the automotive industry to achieve strategic benefits from B2B e-commerce. The following characteristics are relevant: customer/supplier power and compatibility issues.

Jun & Cai (2003) investigate key EDI obstacles experienced by US small manufacturing firms and examine the relationship between identified obstacles and benefits. They use seven obstacles (i.e., characteristics) to measure the impact on EDI adoption: managerial leadership, cost and benefits, technical characteristics, organisational characteristics, trading partner relationships, security, and legal issues.

Hausman & Stock (2003) investigate the adoption and implementation of EDI in hospital supply chains. Factors affecting adoption of technological innovations and those affecting implementation appear to be entirely different. Four characteristics are relevant in adoption of EDI in that case: influence in cooperative adoption, trust, commitment, and the relative cost of implementation.

Weber & Kantamneni (2002) examine the factors why retailers adopt point of sales and EDI. They examine the underlying benefits and barriers to such adoption. The characteristics they discuss are perceived direct and indirect benefits resulting from the adoption, strategic factors, cost, and management attitude.

Chau & Hui (2001) suggest in their findings that small businesses still do not consider EDI as an enabler of business to gain major strategic benefits or competitive advantage. They identify and study seven key determinants (i.e., characteristics) of small business EDI adoption: in the technological context, perceived direct and indirect benefits; in the external environment context, government and business partners’

influence; and in the organisational context, prior EDI experience, perceived support, and perceived costs.

Kuan & Chau (2001) propose a perception-based adoption model for small business EDI. They identify three contexts of relevance. Technology refers to perceived technological benefits; organisation refers to perceived organisational resources; and environment refers to environmental pressure. Each context identifies two characteristics: for technology, perceived direct and indirect benefit; for organisation, perceived financial cost and perceived technical competence, and for environment, perceived industry and government pressure.

Jiménez-Martínez & Polo-Redondo (2001) analyse the opinions and behaviour of the retailing sector in the adoption of EDI. They show how advantages gained by use of telecommunications and standards, the environment of the firm, and the internal situation of the firm influence the adoption. Four groups of factors are contemplated: network factors, innovation factors, intra-organisational factors, and inter-organisational factors. In these factors the following characteristics are relevant for the expansion of EDI: use of technologies, flexibility of company, support, incentives from top management, cost, diverse use of IT, organisational structure, coercion, integration, and more innovative technology.

Vijayasathy & Tyler (1997) study the EDI use in the retail industry. The purpose of their research is to ascertain the primary factors that prompt firms to adopt EDI. The factors that were assessed include cost savings, strategic benefits, pressure from trading partners, and improved channels.

Crum, Premkumar, & Ramamurthy (1996) assess the adoption, use and satisfaction of EDI in the motor car industry. Two factors influencing the adoption of EDI exist: environmental and organisational. The former includes competitive pressure, customer support, net dependence, and transaction climate (trust). The latter includes compatibility, complexity, cost, EDI champion, perceived need, and top management support.

Iacovou, Benbasat, & Dexter (1995) investigate the adoption and impact of EDI in small organisations. Three major factors are identified that influence the EDI adoption practice in small firms: organisational readiness because of the low levels of IT sophistication and resource

availability in small firms; external pressure to adopt because of the weak market positions of small firms and the network nature of the technology; and perceived benefits because of the limited impact that IT has on small firms due to under-utilisation and lack of integration.

Howells & Wood (1995) investigate the adoption of EDI in pharmaceutical and healthcare sector. Inter-organisational dynamics raise specific issues for the adoption and diffusion of such a technology between different organisations. The characteristics relevant for that study are cost of adoption, standards, uncertainty, and unsuitability or lack of perceived benefits of adoption.

Banerjee & Golhar (1994) define key issues of EDI from both the users' and the non-users' perspective. Five categories (with characteristics) are identified: customer-related factors (customer requests, better customer service, sales), communication-related factors (response time, data accuracy, better and faster communication, data control, administration), peer pressure (competition, industry standards, service quality), productivity (processing ease, aid, ease of tracing, internal efficiency, productivity), and cost (administration, manufacturing, employees, inventory).

7.1.3 Characteristics Used in RFID Research

Sharma, Thomas, & Konsynski (2008) present a study of the organisational implementation of RFID because the adoption of new and emerging technologies with unique characteristics is not well understood. The factors that drive RFID technology adoption are divided into an institutional theory rationale and a strategic rationale. The former includes coercive pressure (e.g., by regulatory bodies or predominant organisations), mimetic pressure (e.g., mimic firms perceived as industry leaders), and normative pressure (e.g., agreement on norms). The latter includes organisational readiness (i.e., top management support, IS infrastructure, IS capabilities, financial readiness), perceived RFID factors (direct and indirect benefit, cost), and environmental factors (i.e., standards and privacy concerns).

Whitaker, Mithas, & Krishnan (2007) investigate the impact of technological and financial resources on RFID benefits. They suggest there is a positive association between IT application deployment and

RFID adoption. The characteristics included in the evaluation are IT integration (i.e., broad IT applications), cost (i.e., financial resources of a firm), partner mandate (i.e., pressure by predominant firm), standards (i.e., industry-wide norms), and firm size.

Cheon-Pyo & Shim (2007) examine the RFID adoption decision process and propose a model predicting the likelihood of adopting RFID within organisations in the healthcare industry. The findings show that besides technology factors, other factors are important for the adoption of RFID. These other factors (i.e., characteristics) are identified as: performance gap (i.e., perceived shortcomings of the organisation), market uncertainty (e.g., competition or opportunities), vendor pressure (e.g., supplier marketing activities), perceived benefits (i.e., relative advantage), and presence of champions (i.e., management-level involvement). These characteristics are supported by organisational readiness (i.e., financial or technology resources) as moderator.

Tajima (2007) provides insight into the strategic value and competitive advantage of RFID. Lack of return on investment (ROI), technical risks (e.g., unreliability), popularity of other technology (e.g., barcodes), and privacy concerns are the RFID adoption barriers identified. The RFID adoption benefits are summarised as follows: throughout the entire supply chain the characteristics are shrinkage reduction, material-handling reduction, data accuracy, exception management, information sharing; for suppliers they are production tracking, quality control, supply and production continuity; for distributors the characteristics are material handling, space utilisation, asset management; and, finally, for retailers the characteristics are reduction of stock-out, customer service, after-sale service, and inventory.

Sharma, Citurs, & Konsynski (2007) explore factors driving RFID technology adoption and the extent to which different rationales relate to the expected adoption and integration of RFID. The constructs they use are technology (perceived benefit and cost); organisational readiness (top management support, IS infrastructure, financial readiness, diffusion champion, organisational readiness), inter-organisational pressure (competitive pressure, predominant partner pressure, industry/regulatory pressure, favourable climate), and external environment (tag cost reduction, standards adoption, IP ownership, and privacy concerns).

Huyskens & Loebbecke (2007) attempt to clarify how the processes of RFID adoption by companies and industry diffusion happen and which factors are relevant. They derive three theoretical concepts and ten associated factors of organisational technology adoption and diffusion. First, external influences: coercive pressure, isomorphic pressure, and information availability. Second, perceived organisational benefits: integration efforts, standards availability, quality, and financial benefits. Third, organisational characteristics: IT commitment, top management support, and size.

Brown & Bakhru (2007) criticise the traditional research methods of ICT adoption and diffusion for RFID and view them as inappropriate. Instead of focusing on the individual technology and its characteristics, an effective description of technology diffusion would require a model specific to the technology. In the case of RFID the factors should thus be the business case, implementation issues, risks, and community beliefs and attitudes.

Brown & Russell (2007) conduct an exploratory investigation into RFID adoption in retail organisations to identify factors that have an impact on the adoption status. A three-context approach is followed. First, the technological context is analysed with the characteristics relative advantage, compatibility, complexity, and cost. Second, the organisational context is analysed with the characteristics top management support, IT expertise, size, and organisational readiness. Finally, the environmental context is analysed with the characteristics competitive pressure, external support, and change agents.

Seymour, Lambert-Porter, & Willuweit (2007) review the adoption of RFID in the container supply chain. They propose factors that could affect the adoption of RFID into container port communities. They draw on the theoretical framework for innovation adoption and implementation with 7 factors and 18 themes (i.e., characteristics): (i) technology: cost, perceived value/usefulness, complexity/ease of use, accuracy; (ii) organisation: management support, organisation culture, organisational readiness, size; (iii) people: resistance, expertise/training; (iv) environment: organisation policy, facilitating conditions, infrastructure; (v) strategy, structure and rivalry: relative advantage, security; (vi) factor and demand conditions: customer needs/satisfaction, standards; and (vii) related and supporting industries: integrated structure of industry.

Bhattacharya et al. (2007) develop an integrated framework of RFID adoption in the retail industry. Their integrated framework consists of three factors: drivers, benefits, and challenges. Drivers include characteristics, such as benefits, legal/governmental regulations, mandate, and technology drivers. Benefits include characteristics, such as information accuracy, customer service, security, improved sales, visibility, operational efficiency, and costs. Finally, challenges include characteristics, such as process redesign, data integration, reluctance, costs, standards, privacy, and reliability.

Chao, Yang, & Jen (2007) determine technology trends and forecasts of RFID by a historical review and bibliometric analysis from 1991 to 2005. They distinguish two eras: one lasting from 1991 to 2000, and a second one from 2001 onwards. Various types of challenges (i.e., characteristics) in RFID adoption are identified: technology (material/antenna power, radio wave reception, signal collision), standard (lack of unified standard, lack of consistent UHF spectrum), patent, cost (manufacturing and customisation⁹), infrastructure, ROI, and barcode migration.

Wu, Nystrom, Lin, & Yu (2006) examine the existing challenges that RFID technology faces and its future development directions and obstacle resolution approaches. The major challenges (i.e., characteristics) they identify are: technology challenges (material/antenna power, radio wave reception, signal collision), standards challenges (lack of unified standard, lack of consistent UHF spectrum), patent challenges (royalty-free/reasonable and fair licensing), cost challenges (manufacturing and customisation), ROI challenges (cost reduction and value creation), and barcode migration (co-existence of barcode and RFID).

Vijayaraman & Osyk (2006) examine whether empirical data supports the hype on RFID. The reasons for RFID adoption are mandates, visibility (inventory/supply chain), efficiency, asset tracking, stock management, shrinkage, security, cost, store sales and inventory. The reasons for not implementing RFID are foreseeable benefit, cost, funding, standards, integration, and understanding.

⁹ Bhattacharya, Chu, & Mullen (2007) erroneously enumerate manufacturing and customisation cost under patent challenges instead of cost challenges.

Koh, Kim, & Kim (2006) critically explore the success factors of RFID technology for the retail industry. Their study postulates a structural causal relationship among its intrinsic attributes, perceptions, and impact on business performance. The intrinsic attributes include technical attributes (middleware, item-level tagging, label data, EPC standards, mass availability of UHF tags), business attributes (process management, activity monitoring, web services), and data attributes (read/write capability, data accuracy, system automation). The perceived RFID benefits are improved inventory management (stock-out, shrinkage, data collection, real-time inventory, complexity, control, warehouse management), velocity of retail cycle (fashion cycle, assortment, sales floor design, pricing, trend forecasting, information to customer), integrated business model (new business model, online/offline channels, competitive differentiation, transaction processing, connection retailer-supplier), and efficiency of store operation (order visibility, sales floor, stock time, store operation). Finally, the perceived RFID risks are lack of expertise (training time, experts, training cost, reluctance to new technology, information gap), complexity of technology (complexity, manageability, immaturity, reliability, interoperability), and uncertainty of technology (standards, ROI, data reads).

Lai, Wong, & Cheng (2006) explore the perspective of firms that have adopted RFID and those that have followed the example set by their supply chain partners. The study helps understand the institutional isomorphic processes that influence the adoption of RFID in the supply chain. The characteristics, upon which adoption decisions are made, are: coercion (pressure by other organisations), mimesis (force of uncertainty), and norms (normative processes for the establishment of legitimating).

Jones, Clarke-Hill, Hillier, & Comfort (2005) outline the characteristics of RFID technology and the perceived benefits and challenges as they apply to retail. Perceived benefits are improved efficiency, accuracy, security, warehousing, and distribution centres as well as greater inventory visibility. The challenges outlined are the strategic review of business processes, costs, standards, size, and market pressure.

Wyld, Jones, & Totten (2005) examine the adoption of RFID technology in the commercial aviation industry, focusing on baggage handling and security. The characteristics relevant for the adoption of

RFID in the commercial aviation industry are identified as being (market) size, accuracy, efficiency, mandates (by, e.g., government bodies), costs, standards, and ROI.

Lai, Hutchinson, & Zhang (2005) formulate opportunities and challenges or RFID adoption in retailing and supply chain management. They identify several opportunities and challenges. The former include market size, service level, quality control, financial management, profitability, visibility, and anti-counterfeiting. The latter include standards, cost, lack of business models, security, and social instability.

Jones, Clarke-Hill, Comfort, Hillier, & Shears (2005) offer an outline of the characteristics of RFID technology and the perceived benefits and challenges for the food retail market. In food retailing, a wide range of perceived benefits are claimed: management control, inventory management, costs, service, shrinkage, tracking, efficiency, accuracy, public safety risks, and traceability. The challenges claimed relate to the strategic review of business processes, effective use of data, costs (e.g., for training), and privacy concerns.

7.2 Lack of Legal Perspectives in IS Research

Two outcomes are apparent and noteworthy from the review of the IT, EDI, and RFID articles, moving from the general to the more specific remarks:

First, the characteristics are grouped into clusters like, for instance, ICT, market, and organisation (Papastathopoulou et al., 2007); innovation, organisation, and environment (Premkumar & Roberts, 1999); environment, structure, and IS (Grover & Goslar, 1993); organisation, technology, and environment (Brown & Russell, 2007; Chau & Hui, 2001; Kuan & Chau, 2001; Seyal et al., 2007; Sharma et al., 2007); environment and organisation (Crum et al., 1996); institutional theory and strategy (Sharma et al., 2008); supply chain, supplier, distributor, and retailers (Tajima, 2007); drivers, benefits, and challenges (Bhattacharya et al., 2007); as well as intrinsic attributes, perceptions, and business performance (Koh et al., 2006). However, despite the fact that a few articles refer to legal characteristics in the narrow or wide sense (see Section 4.3), there is no dedicated legal cluster. The legal characteristics are used either:

(i) in the environmental cluster (Sharma et al., 2007; Sharma et al., 2008); (ii) in the retail cluster (Tajima, 2007); (iii) in the driver and challenges clusters (Bhattacharya et al., 2007); or (iv) in no specific cluster (Chao et al., 2007; Jun & Cai, 2003; Wu et al., 2006).

Second, of the total of 392 characteristics referred to in the 45 articles reviewed only 31 are legal characteristics: 16 on standards, five on privacy issues, five on mandates, three on IP issues, and two on general legal issues. Table 18 shows a summary of the most popular characteristics, ranging from 5 uses per characteristic upwards (the full table is presented in Appendix 6). Furthermore, it also includes the two legal characteristics patent and copyright (IP) and general legal issues, which only are reflected three times, and twice respectively. If one looks at the individual characteristics, then the ratio is 150 different characteristics to 5 legal characteristics.

Given that only the social cognitive theory of the ten adoption and diffusion theories outlined in Section 3.1.4 explicitly mentions the awareness of moral rules and regulations as characteristic, the poor yield of legal characteristics in the IS research, let alone the lack of a dedicated legal cluster, is unsurprising. On the one hand, one can derive from Table 18 that the characteristics with legal connotation are reflected almost solely in the articles on RFID technology (there are none in the articles on IT and only five in the articles on EDI). The remaining 26 cases of legal characteristics are all reflected in the articles on RFID. This finding allows the assumption that legal awareness might be changing with the technological innovation. On the other hand, however, one can derive from the literature review of these 45 articles that regulation by law mostly is irrelevant for IT and only a subordinately relevant for EDI and RFID role in IS research.

This leads to the first hypothetical claim:

<p><i>Hypothetical Claim 1:</i> <i>There is a lack of legal perspectives in IS research.</i></p>
--

7.3 Lack of Diversity in Regulation of Technological Innovation in IS Research

To be effective, regulation cannot be top-down. Regulators must be aware of the regulatee's own internal logic and practices. Proponents of alternatives to the command and control model of regulation aim to shape regulation through insinuation rather than command, through procedure rather than stipulation. Simply increasing either the amount of regulation or increasing its precision will not work (Black, 1999). Bronwen & Yeung (2007) note that lawyers have tended to focus on regulation by law, and not on other regulation, such as regulation by norms, because of the state's monopoly on coercive power by the law. According to these authors, regulation scholarship is challenging three assumptions inherent in such perspective: (i) that the state is the primary locus for articulating the collective goals of a community; (ii) that the state's role is hierarchical in nature; and (iii) that the centrality of rules is the primary mode of shaping behaviour. Decentred regulation (Black, 2001) generates new questions about the relationship between the state and other actors. Bronwen & Yeung (2007) note that "finding answers to these questions will require lawyers to broaden their horizons beyond the vision of the state as a top-down rule-maker" but nonetheless "they do not eliminate the relevance of law, nor a legal perspective on regulation" (p. 4). Hence, other actors (see Section 3.2.1) and other modalities (see Section 3.2.2) play an increasingly important role in establishing and implementing regulation.

In Section 3.2 it has been suggested that regulation should follow diverse approaches. Whether it is Lessig's (1999) four modalities law, social norms, market, and architecture; Scott's (2004) reclassification to hierarchy, community, competition, and design; or Bronwen & Yeung's (2007) five "Cs", command, consensus, competition, code, and communication, is not the prime concern here. The fact that regulation must include several regulatory disciplines seems well warranted. If one looks at the application of regulation in ICT (see Section 3.2.3), diversity seems implemented.

After all:

1. Legal frameworks should hold online as they do offline. This is regulation by law.
2. ICT regulation should not only be driven by government, but the industry should have the duty of self-regulation. This is either regulation by law (in the wide sense) or regulation by social norms.
3. ICT regulation should be technology-neutral. This is regulation by law.
4. ICT regulation should be harmonised at an international level. This is either regulation by law or by market.
5. ICT could be regulated by means of technology. This is regulation by architecture.

The following critique extends to IS research. The literature review of the 45 IT, EDI, and RFID articles reveals a discrepancy to the proposed diversity in regulation. The characteristics relevant for the adoption and diffusion of technological innovation are grouped into different clusters (see Section 7.2). At first glance and with some goodwill one can interpret certain regulatory modalities into the IS research of adoption and diffusion of technological innovation. For instance,

- to market (Papastathopoulou, Avlonitis, & Panagopoulos, 2007);
- to environment (social norms) (Premkumar & Roberts, 1999; Grover & Goslar, 1993; Brown & Russell, 2007; Chau & Hui, 2001; Kuan & Chau, 2001; Seyal, Rahman, & Mohammad, 2007; Sharma, Citurs, & Konsynski, 2007; Crum, Premkumar, & Ramamurthy, 1996; Sharma et al., 2007; Sharma, Thomas, & Konsynski, 2008);
- to technology (Brown & Russell, 2007; Chau & Hui, 2001; Kuan & Chau, 2001; Seyal et al., 2007; Sharma et al., 2007); and
- to communication (Banerjee & Golhar, 1994).

But upon closer inspection, especially of the details and meaning of the characteristics, the premise of diversity seems to be missing. Only

security (Jun & Cai, 2003) seems to be related to regulation by architecture (or code or design). One might ask the question how IS research on the adoption and diffusion of IT, EDI, and RFID relates to regulation. The point is that, as noted earlier, regulation should not be top-down. It should include the stakeholders. The scholars of the 45 IS research papers reviewed claim to have investigated the industry. In such event, if there were diverse regulation that would influence the industry, it would need to reflect in the characteristics of adoption and diffusion of technological innovation. But it does not; on the contrary.

This leads to the second hypothetical claim:

<p><i>Hypothetical Claim 2:</i> <i>There is a lack of diversity in regulation of technological innovation in IS research.</i></p>
--

7.4 Chapter Summary

Chapter 7 stipulates two hypothetical claims as second premise of abductive reasoning. A literature review of IT, EDI, and RFID research articles shows that regulatory characteristics are not prominent in IS research. Of the 150 different characteristics that were analysed in the research articles only 5 are legal characteristics. It can therefore be hypothetically claimed that in IS research there is a lack of legal perspectives. Furthermore, a review of regulation shows that there seem to be theoretical approaches to a diversified regulation of ICT. However, the focus still seems to be on regulation by law and not by other means, such as social norms, market, or architecture. It can therefore be hypothetically claimed that in IS research there is also lack of diversity in regulation of technological innovation.

Chapter 8

Conclusion

Chapter 8 concludes this thesis by providing the last premise of abduction. Table 19 (see next page) inverts Table 1. The inference in the conclusion is based on the two hypothetical claims. These two hypothetical claims help explain the anomaly of the findings in the four observations. The four observations are based on the four individual articles of Part Two of this thesis.

It is argued in this chapter that the two hypothetical claims identified in Sections 7.2 and 7.3 probably have to be true in order to explain the surprising facts of the four observations in Chapter 6. The rules of the two hypothetical claims and the results of the four observations are joined according to Table 19 in the subsequent four sub-sections to finalise the third premises of abductive reasoning.

8.1 Observation 1 and Hypothetical Claim 2

The result of the Database Article observes certain experience with regard to technological innovation and regulation, specific with database regulation that is applicable to RFID data. Observation 1 suggests that the regulation of databases does not play an important role in the strategic management decisions for the location of RFID systems. This is surprising. After all, Europe and the USA are, among others, strong competitors in ICT. The analysis of database protection in Europe and North America suggests that regulation by law is inappropriate in this respect. All three doctrines of database protection analysed – the creativity, the skill and judgement, and the investment doctrine – do not protect the RFID data in a database.

Conclusion				3 rd premise
Hypothetical Claim 1 There is a lack of legal perspectives in IS research.		Hypothetical Claim 2 There is a lack of diversity in regulation of technological innovation in IS research.		2 nd premise
O 2 Extending the doctrinal definition of active RFID tags to include reader-independent and indiscriminate signalling might lead to unfavourable regulation by law.	O 4 The interactions between, and consequently also the exchange of expert know-how and standpoints of, (i) the RFID industry and the legal regulator and (ii) the RFID industry and the consumers seem insufficient.	O 1 Despite the amount of data anticipated to be stored and the regulation by law in the different countries where RFID is adopted and diffused, the location of the databases containing RFID data does not seem to play an important role for the technological innovator.	O 3 The current adoption and diffusion of RFID technology do not seem to be following an appropriate mix of regulation.	1 st premise
Marketing Article	Survey Article	Database Article	Modality Mix Article	
Research Question How can the adoption and diffusion of RFID be balanced successfully between technological innovation and regulation by law?				Research Method Abduction

Table 19: Relationship between the conclusion, the hypothetical claims, the observations (O 1 – O 4), and the research question; including 3 premises of abduction.

It has been established by the example of the Database Article that it might be regrettable that in the instance of the *sui generis* Database Directive (96/9/EC) in Europe the goal of promoting Europe as *the* strategic region for database protection has been derogated by the ECJ. Such missing database protection is regulation by law in the narrow sense (see Section 4.5) and as such it is unlikely to be influenced directly by the RFID industry in the short run.

The Hypothetical Claim 2 suggests that in IS research there is a lack of diversity in the regulation of technological innovation. The analysis has shown that, if at all, only legal characteristics prevail in IS research on the adoption and diffusion of ICT. Other regulatory modalities do not seem to be deemed relevant. The authors of the articles reviewed claim to have researched the industry. This likely indicates that also the industry does not view legal or other modalities relevant, or else the characteristics of adoption and diffusion reflecting regulation would have been included in such research. Given Observation 1 and Hypothetical Claim 2, it seems plausible to build the case, i.e., to conclude, that increasing the diversity of regulation modalities might have positive effect on the strategic management decisions for the location of RFID systems. Or formulated more generally: using the available regulatory tools more diversely might have a positive effect on the adoption and diffusion of RFID. This premise assumes that the strategic advantage as stipulated above will indeed foster the adoption and diffusion of technological innovation.

8.2 Observation 2 and Hypothetical Claim 1

The result of the Marketing Article observes certain experience with regard to technological innovation and regulation, specifically, with potential legal (negative) consequences of the marketing of technological innovation. Observation 2 stipulates that extending the doctrinal definition of active RFID tags to include reader-independent and indiscriminate signalling might lead to unfavourable regulation by law. The analysis of the RFID industry's marketing efforts and the legal community's interpretation of RFID technology shows that unfavourable regulation by law is possible and likely. Adopting the broad legal interpretation of self-emitting devices (short-range devices) to RFID tags that need to transduce energy from an RFID

reader (active RFID tags) might make search and seizure of transmitted RFID data constitutional without a warrant. As protective measure against too broad a utilisation of RFID technology, the replication of such an adjudication might trigger more stringent regulation by law.

It has been suggested by the example of the Marketing Article that the RFID industry is unaware of important regulation by law in the narrow sense. It is questioned whether the RFID industry would market short-range devices as active RFID tags, as it currently does, if it were aware of the potential legal consequences. Such consequences could hamper the adoption and diffusion of technological innovation.

The Hypothetical Claim 1 suggests that in IS research there is a lack of legal perspectives. The analysis has shown that legal characteristics play only a marginal role in the evaluation of the adoption and diffusion of technological innovations. Given Observation 2 and Hypothetical Claim 1, it seems plausible to build the case, i.e., to conclude, that increasing the legal perspective in IS research might have a positive effect on the RFID industry's marketing strategy. If the industry becomes more aware of legal issues through IS research, then the marketing strategy could change in such manner as to prevent unfavourable adjudication and/or more stringent legislation, which in turn could foster the adoption and diffusion of RFID. Or formulated more generally: increasing the legal perspective in IS research might have a positive effect on the adoption and diffusion of RFID.

8.3 Observation 3 and Hypothetical Claim 2

The result of the Modality Mix Article observes certain experience with regard to technological innovation and regulation, in specific the missing diversity in the regulation of RFID technology. Observation 3 stipulates that the mix of regulation in the adoption and diffusion of RFID technology is inappropriate. The analysis of the Draft Recommendation (2008) shows that the focus on regulation by law is in fact inappropriate. The regulation of RFID technology seems to focus too much on regulation by law. Not only does certain regulation by law prove unenforceable but many concerns could also be addressed more effectively by other modalities of regulation.

It has been established by the example of the Modality Mix Article that an over-regulation of RFID technology by regulation by law is possible if the Draft Recommendation (2008) is implemented and comes into force. In summary, this research has identified certain shortcomings in the diversity of technological innovation based on the example of RFID-related regulation *de lege lata* as well as *de lege ferenda*. An initial solution might be to rethink the focus of regulation of technological innovation. A broader and more bespoke exploitation of the possible modalities of regulation seems more appropriate to successfully regulate technological innovation. Such a set of modalities should be balanced better and include regulation by norms, market, and architecture.

The Hypothetical Claim 2 suggests that in IS research there is a lack of diversity in the regulation of technological innovation. The analysis has shown that, if at all, only legal characteristics prevail in IS research on the adoption and diffusion of ICT. Other regulatory modalities do not seem to be deemed relevant in IS research. The authors of the articles reviewed claim to have researched the industry. This likely indicates that also the industry does not view legal or other modalities relevant, or else the characteristics of the adoption and diffusion reflecting regulation would have been included. Given Observation 3 and Hypothetical Claim 2, it seems plausible to build the case, i.e., to conclude, that a more thorough and precise review of essential regulation by law is necessary. Critically reviewing what kind of regulation by law is essentially needed could make room for regulation by the other modalities that might be better suited as regulatory means. Or formulated more generally: using the available regulatory tools more diversely might have a positive effect on the adoption and diffusion of RFID.

8.4 Observation 4 and Hypothetical Claim 1

The result of the Survey Article shows certain experience with regard to technological innovation and regulation, specifically, the RFID industry's relation with regulation by law. Observation 4 stipulates that interactions between, and consequently also the exchange of expert know-how and standpoints of, (i) the RFID industry the RFID industry and the legal regulator and (ii) the RFID industry and the consumers

seem insufficient. The analysis of the survey data of the RFID industry suggests that a substantial part of the RFID industry does not engage any legal experts in matters concerning RFID technology. The analysis also suggests that the RFID industry is partly unaware of the necessary regulation by law for RFID subject-matter. Finally, the analysis suggests that the consumers are badly informed about RFID-related matters. It seems likely that the insufficient information policy is not only the fault of the legal regulator and consumer organisations but also that of the RFID industry itself.

It has been stipulated by the example of the Survey Article that the professional exchange between the RFID industry and both the legal regulator and the consumers seem insufficient. Therefore it is anticipated that this exchange needs to improve. Such an improvement would presume that the RFID industry acknowledges that certain shortcomings are self-inflicted.

The Hypothetical Claim 1 suggests that in IS research there is a lack of legal perspectives. The analysis has shown that legal characteristics only play a marginal role in the evaluation of the adoption and diffusion of technological innovations. Given Observation 4 and Hypothetical Claim 1, it seems plausible to build the case, i.e., to conclude, that increasing the legal perspectives in IS research might have a positive effect on the RFID industry's awareness of legal challenges and consequences. There are certainly different means to make the RFID industry aware of legal issues. Doing so via IS research might be a smooth way to create awareness, which might then increase customer information policy and lastly the customer's satisfaction. Or formulated more generally: increasing the legal perspectives in IS research might have a positive effect on the adoption and diffusion of RFID.

8.5 When Bits Learn to Walk Don't Make Them Trip

The research question that is formulated in Section 1.2.3 and that this thesis tentatively answers is:

Research Question: How can the adoption and diffusion of RFID be balanced successfully between technological innovation and regulation by law?

As one might anticipate from the outcome so far, there is no straightforward answer to the question. The two generalised conclusions derived from the two hypothetical claims and four observations propose that:

1. increasing the legal perspectives in IS research might have a positive effect on the adoption and diffusion of RFID; and
2. using the available regulatory tools more diversely might have a positive effect on the adoption and diffusion of RFID.

At first glance, it might seem as if these two conclusions exclude one another: how can regulation be more diverse if the legal perspective needs to be increased. After all, as Lessig (1999) noted, the *net* regulation is the sum of all four regulation tools. So if the implementation of one of the tools (i.e., law) increases, then there is by definition less space for the other regulatory tools. Diversity is prone to decrease, not increase.

However, the point is that it is not suggested there be *more regulation* by law. The view of Black (1999) is shared herein that simply increasing either the amount of regulation or increasing its precision will not work. The suggestion is that the legal *perspectives* be increased. This is not the same as increasing regulation by law per se. The legal perspectives in IS research, and consequently also in the RFID industry, can increase without convoluting regulation by law. Being (more actively) aware of regulation by law in the narrow and the wide sense could – as proposed herein – widen the legal perspectives. This in turn could open discussions on other regulatory tools and foster more diverse regulation. Hence, to this extent the two conclusions complement rather than exclude each other.

Finally, to answer the research question, it is suggested that, to prevent bits from falling once they have learned to walk, the legal perspectives of regulation as well as the diverse implementations of regulation should be increased. Such an increase might increase the

awareness for the potential of regulation in technological innovation. This awareness in turn might foster the adoption and diffusion of RFID. This would seem to be one successful way to balance the adoption and diffusion of RFID between technological innovation and regulation by law.

8.6 Future Research

Viewed on a timeline, abduction initiates all inquiry, whereas induction and deduction follow abduction: “Abduction initiates all inquiry, and induction and deduction play merely a secondary critical roles.” (p. 42) (Cooke, 2006). Abduction provides the explanation through which phenomena are understood, whereas induction, for instance, merely tests the consequences of the hypotheses with regard to reality (Cooke, 2006). As Peirce noted: “[E]very plank of [induction and deduction] is first laid by retroduction alone, that is to say, by the spontaneous conjectures of instinctive reason; and neither [d]eduction nor [i]nduction contributes a single new concept to the structure” (p. 42) (EP2:443 in: Cooke, 2006). Contrary to abduction, induction and deduction must presuppose the contributions of abduction. Induction and deduction (see Figure 10) are needed to evaluate hypotheses.

Based on the selected abductive research method and the caveats outlined in Section 5.7 for interpreting the empirical data of this thesis, future inductive or deductive research is necessary to verify (or falsify) the tentative conclusions made herein. It is suggested that the four cases (conclusions) built in this thesis provide a solid foundation for the following four hypotheses that can be further tested with additional empirical data:

1. Increasing the diversity of regulation modalities has a positive effect on the strategic management decisions for the deployment location of technological innovation.
2. Increasing the legal perspective in IS research has a positive effect on the marketing strategy for technological innovation.
3. Increasing the thoroughness and precision in the review of essential regulation by law has a positive effect on other regulatory tools for technological innovation.

4. Increasing the legal perspective in IS research has a positive effect on the industry's awareness of the legal challenges and their consequences.

References

- _____. (17 January 2007). *Information Society Consultations*. Retrieved June 1, 2008, from URL http://ec.europa.eu/information_society/tl/activities/consultations/index_en.htm#open_consultations.
- _____. (2007). *Communication from the Commission to the European Parliament, the Council, the European Economic and Social Committee and the Committee of the Regions. Radio Frequency Identification (RFID) in Europe: Steps Towards a Policy Framework* (Communication No. COM (2007) 96 final). Brussels: Commission of the European Communities.
- _____. (11 March 2003). Wal-Mart, DOD forcing RFID. *Wired*.
- AeroScout Inc. (2008). *Aeroscout T3 Tag*. Retrieved November 1, 2008, from URL <http://www.aeroscout.com/leadcapture/files/AeroScout+T3+Tag+Data+Sheet.pdf?leadreturn=1> (open registration required).
- Agi, M., Ballot, E., & Molet, H. (2005). "100% EDI-Connected Suppliers" Projects: An Empirical Investigation of Success Factors. *Journal of Purchasing & Supply Management*, 11, 107-115.
- Ajzen, I. (1991). The Theory of Planned Behavior. *Organizational Behavior and Human Decision Processes*, 50(2), 179-211.
- Albrecht, K. C.A.S.P.I.A.N. *Consumers Against Supermarket Privacy Invasion and Numbering*. Retrieved May 27, 2009, from URL <http://www.nocards.org/>.
- Albrecht, K., & McIntyre, L. *Spychips.com*. Retrieved May 27, 2009, from URL <http://www.spychips.com/>.
- American Express. (2008). *American Express Personal Cards*. Retrieved November 14, 2008, from URL <https://www124.americanexpress.com/cards/ExpresspayNew/moreQuestions.html#q02>
- Angeles, R. (2007). An Empirical Study of the Anticipated Consumer Response to RFID Product Item Tagging. *Industrial Management & Data Systems*, 107(4), 461-483.

- Animal Identity Service AG. (2008). *ANIS*. Retrieved November 16, 2008, from URL <http://www.anis.ch/en/home/>.
- Asamoah, A. K. (2006). Not as Easy as it May Appear: Using Radio Frequency Identification Technology to Fulfill the Prescription Drug Marketing Act's Elusive Pedigree Requirement. *Food and Drug Law Journal*, (61), 385-418.
- Attewell, P. (1992). Technology Diffusion and Organizational Learning: The Case of Business Computing. *Organization Science*, 3(1), 1-19.
- Auto Access ID. (2007). *AA-T800*. Retrieved December 9, 2007, from URL <http://www.autoaccessid.com/Files/File/Cutsheets/AA-T800.pdf>.
- Axcess Inc. (2008). *Active Radio Frequency Identification Active Tag*. Retrieved November 1, 2008, from URL <http://www.axcessinc.com/products/docs/containeritag.pdf>.
- Ayres, I., & Braithwaite, J. (1992). *Responsive Regulation: Transcending the Deregulation Debate*. Oxford: Oxford University Press.
- Bagozzi, R. P., Davis, F. D., & Warshaw, P. R. (1992). Development and Test of a Theory of Technological Learning and Usage. *Human Relations*, 45(7), 659-686.
- Bandura, A. (1986). *Social Foundation of Thought and Action: A Social Cognitive Theory*. Englewood Cliffs: Prentice-Hall.
- Banerjee, S., & Golhar, D. Y. (1994). Electronic Data Interchange: Characteristics of Users and Nonusers. *Information & Management*, 26, 65-74.
- Barlow, J. P. Selling Wine Without Bottles: The Economy of Mind on the Global Net. Retrieved May 22, 2009, from URL http://w2.eff.org/Misc/Publications/John_Perry_Barlow/HTML/idea_economy_article.html
- Barlow, J. P. (1996). *A Declaration of the Independence of Cyberspace*. Retrieved May 23, 2009, from URL <http://homes.eff.org/~barlow/Declaration-Final.html>.
- Barnett, H. (1953). *Innovation*. New York: Mc Graw Hill.
- Barroso, J. M., & Verheugen, G. (2005). *Working Together for Growth and Jobs a New Start for the Lisbon Strategy*. (Communication

- No. COM (2005) 24). Brussels: Commission of the European Communities.
- Becker, S. W., & Whisler, T. L. (1967). The Innovative Organization: A Selective View of Current Theory and Research. *Journal of Business*, 40(4), 511-518.
- Beer, S. (1966). *Decision and Control: The Meaning of Operational Research and Management Cybernetics*. London: Wiley.
- Bensky, A. (Ed.). (2004). *Short-Range Wireless Communication* (2nd edition). Amsterdam: Elsevier.
- Bhattacharya, M., Chu, C., & Mullen, T. (2007). RFID Implementation in Retail Industry: Current Status, Issues, and Challenges. *Decision Science Institute (DSI) Conference 2007*, Phoenix, AZ.
- Black, J. (1999). Using Rules Effectively. In C. McCrudden (Ed.), *Regulation and Deregulation* (pp. 95-121). Oxford: Clarendon Press.
- Black, J. (2001). Decentring Regulation: The Role of Regulation and Self Regulation in a "Post Regulatory" World. *Current Legal Problems*, 54, 103-146.
- Black, J. (2002). Regulatory Conversations. *Journal of Law and Society*, 29(1), 163-196.
- Blind, K. (2004). *The Economics of Standards: Theory, Evidence, Policy*. Cheltenham: Edward Elgar.
- Bora, A. (2008). Innovationsregulierung als Wissensregulierung. In M. Eifert, & W. Hoffmann-Riem (Eds.), *Innovationsfördernde Regulierung* (pp. 23-43). Berlin: Duncker & Humblot.
- Braithwaite, J. (1984). *Corporate Crime in the Pharmaceutical Industry*. London: Routledge and Kegan Paul.
- The British Horseracing Board Limited and Others v. William Hill Organization Ltd*, (C-203/02) (2004).
- Brito, J. (2004). Relax Don't Do It: Why RFID Privacy Concerns are Exaggerated and Legislation is Premature. *UCLA Journal of Law and Technology*, (2004), 5. Retrieved October 1, 2009, from URL http://www.lawtechjournal.com/articles/2004/05_041220_brito.php.

- Bronwen, M., & Yeung, K. (2007). *An Introduction to Law and Regulation*. Cambridge: Cambridge University Press.
- Brown, A., & Bakhru, A. (2007). Information Systems Innovation Research and the Case of RFID. In T. McMaster, D. Wastell, E. Ferneley & J. DeGross (Eds.), *IFIP International Federation for Information Processing. Organizational Dynamics of Technology-Based Innovation: Diversifying the Research Agenda* (Volume 235, pp. 363-376). Boston: Springer.
- Brown, I., & Russell, J. (2007). Radio Frequency Identification Technology: An Exploratory Study on Adoption in the South African Retail Sector. *International Journal of Management*, 27(4), 250-265.
- Brownsword, R. (2008). *Rights, Regulation, and the Technological Revolution*. Oxford: Oxford University Press.
- Buckley, J. (2003). *Telecommunications Regulation*. London: IEE.
- Buckley, J. (2006). *From RFID to the Internet of Things. Pervasive Networked* (Conference Organised by DG Information Society and Media, Networks and Communication Technologies Directorate). Final Report. Brussels.
- Bundesministerium des Innern. (2008). *Warum werden Elektronische Pässe eingeführt?* Retrieved November 14, 2008, from URL <http://www.epass.de/>.
- Burrell, G., & Morgan, G. (1979 (reprinted 2001)). *Sociological Paradigms and Organisational Analysis*. Hants, England: Ashgate Publishing Limited.
- C.A.S.P.I.A.N. *Boycott Gillette*. Retrieved May 27, 2009, from URL <http://www.boycottgillette.com/index.html>.
- Calliess, C. (2008). Innovationsförderung durch Koppelung von Genehmigung und Alternativprüfung? In M. Eifert, & W. Hoffmann-Riem (Eds.), *Innovationsfördernde Regulierung* (pp. 221-242). Berlin: Duncker & Humblot.
- Canadian Cattle Identification Agency. (2008). *CCIA Tag Standards and Specifications*. Retrieved November 14, 2008, from URL http://www.canadaid.com/about_us/documents/CCIATagStandardsandSpecificationsexporters.pdf.

- Cheon-Pyo, L., & Shim, J. P. (2007). An Exploratory Study of Radio Frequency Identification (RFID) Adoption in the Healthcare Industry. *European Journal of Information Systems*, 16, 712-724.
- Clarke, M. (2000). *Regulation: The Social Control of Business between Law and Politics*. Hampshire: MacMillan Press Ltd.
- Commission of the European Communities. (2006). *The RFID Revolution: Your Voice on the Challenge, Opportunities and Threats*. Online Public Consultation - Preliminary Overview of the Results.
- Compeau, D. R., & Higgins, C. A. (1995). Computer Self-Efficacy: Development of a Measure and Initial Test. *MIS Quarterly*, 19(2), 189-211.
- Conorzio Latterie Virgilio. (2008). *The Conorzio Latterie Virgilio Tries Out the Talents from the Competition Movi&Co*. Retrieved November 14, 2008, from URL <http://www.e-virgilio.com/include/fileviewer.asp?ID=1021>.
- Cooke, E. F. (2006). *Peirce's Pragmatic Theory of Inquiry: Fallibilism and Indeterminacy*. London: Continuum.
- Council Regulation (EC) No. 2252/2004 of 13 December 2004 on Standards for Security Features and Biometrics in Passports and Travel Documents Issued by Member States, (2004). Retrieved from URL <http://eur-lex.europa.eu/LexUriServ/LexUriServ.do?uri=OJ:L:2004:385:0001:0006:EN:PDF>
- Couper, M. P. (2000). Web Surveys. A Review of Issues and Approaches. *Public Opinion Quarterly*, 64, 464-494.
- Craighead, C. W., & Laforge, R. L. (2003). Taxonomy of Information Technology Adoption Patterns. *International Journal of Production Research*, 41(11), 2431-2449.
- Croley, S. (1998). Theories of Regulation: Incorporating the Administrative Process. *Columbia Law Review*, 1, 1-168.
- Crum, M. R., Premkumar, G., & Ramamurthy, K. (1996). An Assessment of Motor Carrier Adoption, Use, and Satisfaction with EDI. *Transportation Journal*, 35(4), 44-57.

- Dalal, R. S. (2006). Chipping Away at the Constitution: The Increasing Use of RFID Chips Could Lead to an Erosion of Privacy Rights. *Boston University Law Review*, (86), 485 et seq.
- Damanpour, F., & Evan, W. M. (1984). Organizational Innovation and Preference: The Problem and Organizational Lag. *Administrative Science Quarterly*, 29(3), 392-409.
- Damanpour, F., & Wischnevsky, J. D. (2006). Research on Innovation in Organizations: Distinguishing Innovation-Generating from Innovation-Adopting Organizations. *Journal of Engineering and Technology Management*, 23, 269-291.
- Davis, F. D., Bagozzi, R. P., & Warshaw, P. R. (1989). User Acceptance of Computer Technology: A Comparison of Two Theoretical Models. *Management Science*, 35(8), 982-1003.
- Davis, F. D., Bagozzi, R. P., & Warshaw, P. R. (1992). Extrinsic and Intrinsic Motivation to Use Computers in the Workplace. *Journal of Applied Social Psychology*, 22(14), 1111-1132.
- Davis, F. D. (1989). Perceived Usefulness, Perceived Ease of Use, and User Acceptance of Information Technology. *MIS Quarterly*, 13(3), 319-340.
- Delaney, K. (2005). RFID: Privacy Year in Review: America's Privacy Laws Fall Short with RFID Regulation. *A Journal of Law and Policy for the Information Society*, 1, 543.
- Draft Recommendation on the Implementation of Privacy, Data Protection and Information Security Principles in Applications Supported by Radio Frequency Identification (RFID): Your Opinion Matters, (2008).
- Drossel, G., & Behn, S. (2008). *HHLA Container Terminals GmbH. A Segment of Hamburger Hafen und Logistik AG*. Retrieved November 14, 2008, from URL http://www.hhla.de/fileadmin/download/HHLA_Container_Broschueere_ENG.pdf.
- Easterbrook, F. H. (1996). Cyberspace and the Law of the Horse. *The University of Chicago Legal Forum*, 207.
- EC, *Directive 96/9/EC of the European Parliament and of the Council of 11 March 1996 on the Legal Protection of Databases*, O.J. L. 77 (27.3.1996).

- EC, *Directive 95/46/EC of the European Parliament and of the Council of 24 October 1995 on the Protection of Individuals with Regard to the Processing of Personal Data and on the Free Movement of such Data*, OJ L 77 (23.11.1995).
- Eden, J. M. (2005). When Big Brother Privatizes: Commercial Surveillance, the Privacy Act of 1974, and the Future of RFID. *Duke Law & Technology Review*, 20, 1-24.
- Eifert, M. (2008). Innovationsfördernde Regulierung. In M. Eifert, & W. Hoffmann-Riem (Eds.), *Innovationsfördernde Regulierung* (pp. 11-19). Berlin: Duncker & Humblot.
- Eleftheriou, D., Berliri, M., & Coraggio, G. (2006). Data Protection and E-commerce in the United States and the European Union. *International Lawyer*, 40(2), 393-402.
- Eng, G. (2005). Technology Trends Affecting the Practice of Law. *Los Angeles Lawyer*, (28-APR), 79.
- EPCglobal Inc. URL: <http://www.epcglobalinc.org> (license required partially).
- EPCglobal Inc. (2007). *Tag Class Definitions*. Retrieved May 30, 2009, from URL http://www.epcglobalinc.org/standards/TagClassDefinitions_1_0-whitepaper-20071101.pdf.
- EPCglobal Inc. (2009). *EPCglobal Standards Overview*. Retrieved May 30, 2009, from URL <http://www.epcglobalinc.org/standards>.
- Eschet, G. (2005). FIPS and PETS for RFID: Protecting Privacy in the Web of Radio. *Jurimetrics Journal*, 45, 301-332.
- European Commission. (2008). *Seventh Research Framework Programme (FP7)*. Retrieved August, 2008, from URL http://cordis.europa.eu/fp7/home_en.html.
- European Commission Information Society Media. (2008). *Internet of Things in 2020 - Roadmap for the Future*. Version 1.1.
- Factiva. Last accessed 29 September 2007, from URL <http://global.factiva.com> (license required).
- Fagerberg, J., Mowery, D. C., & Nelson, R. R. (Eds.). (2005). *The Oxford Handbook of Innovation*. Oxford University Press.

- Fehling, M. (2008). Innovationsförderung durch Staatliche Nachfragemacht. In M. Eifert, & W. Hoffmann-Riem (Eds.), *Innovationsfördernde Regulierung* (pp. 119-144). Berlin: Duncker & Humblot.
- Feist Publications, Inc. v. Rural Telephone Service Company, Inc.*, 499 U.S. 340; 111 S. Ct. 1282; 113 L. Ed. 2d 358; 1991 U.S. LEXIS 1856; 59 U.S.L.W. 4251; 18 U.S.P.Q.2D (BNA) 1275; Copy. L. Rep. (CCH) P26, 702; 68 Rad. Reg. 2d (P & F) 1513; 18 Media L. Rep. 1889; 121 P.U.R.4th 1; 91 Cal. Daily Op. Service 2217 (1991).
- Felten, C. (2001). Adoption und Diffusion von Innovationen. Ein Mikroökonomisches Modell. Bonn: Dissertation, Rheinische Friedrich-Wilhelms-Universität. Doctoral Thesis.
- Finkenzeller, K. (2003). *RFID Handbook* (R. Waddington Trans.). (2nd edition). West Sussex, England: Wiley.
- Finkenzeller, K. (2006). *RFID Handbuch* (4th edition). München: Hanser.
- Finkenzeller, K. (2009). *Radio-Frequency-IDentific@tion*. Retrieved May 31, 2009, from <http://rfid-handbook.de/rfid/standardization.html>.
- Fishbein, M., & Ajzen, I. (1975). *Belief, Attitude, Intention, and Behavior*. Reading: Addison-Wesley.
- Fixtures Marketing Ltd v. Organismos Prognostikon Agonon Podosfairou AE (OPAP)*, (C-444/02) (2004).
- Fixtures Marketing Ltd v. Oy Veikkaus AB*, (C-46/02) (2004).
- Fixtures Marketing Ltd v. Svenska Spel AB*, (C-338/02) (2004).
- Floerkemeier, C., Langheinrich, M., Fleisch, E., Mattern, F., & Sarma, S. E. (Eds.) (2008). *The Internet of Things. First International Conference, IOT 2008, Zurich, Switzerland, March 2008, Proceedings*. Zurich: Springer. *Lecture Notes in Computer Science (LNCS) Vol. 4952, Preface, p. V.*
- fon. (18 May 2009, No. 113). Ein Halber Sieg für den Bundesrat. *Neue Zürcher Zeitung*, p. 7.
- Gerpott, T. J. (2008). Regulierung und Innovationen in der Telekommunikationswirtschaft. In M. Eifert, & W. Hoffmann-Riem

- (Eds.), *Innovationsfördernde Regulierung* (pp. 93-115). Berlin: Duncker & Humblot.
- Gerwin, D. (1981). Control and Evaluation in the Innovation Process: The Case of Flexible Manufacturing Systems. *IEEE Transactions on Engineering Management*, 28(3), 62-70.
- Gibson, W. (1984). *Neuromancer*. New York: Ace Books.
- Glover, B., & Bhatt, H. (2006). *RFID Essentials* (1st edition). Beijing: O'Reilly.
- Goerdeler, A., et al. (July 2007). *European Policy Outlook RFID* (final version). Berlin: Federal Ministry of Economics and Technology (BMWi).
- Goles, T., & Hirschheim, R. (2000). The Paradigm is Dead, the Paradigm is Dead ... Long Live the Paradigm: The Legacy of Burrell and Morgan. *OMEGA - the International Journal of Management Science*, 28, 249-268.
- Google Scholar (BETA). (2008). URL: <http://scholar.google.com>.
- Grover, V., & Goslar, M. D. (1993). The Initiation, Adoption, and Implementation of Telecommunications Technologies in U.S. Organizations. *Journal of Management Information Systems*, 10(1), 141-163.
- Gunter, B. (2002). The Qualitative Research Process. In K. B. Jensen (Ed.), *A Handbook of Media and Communication Research. Qualitative and Quantitative Methodologies* (pp. 209-234). London: Routledge.
- The Guardian Unlimited*. URL: <http://www.guardian.co.uk/>.
- Hancher, L., & Moran, M. (Eds.). (1989). *Capitalism, Culture and Regulation*. Oxford: Clarendon Press.
- Handler, D. (2005). The Wild, Wild West: A Privacy Showdown on the Radio Frequency Identification (RFID) Systems Technological Frontier. *Western State University Law Review*, 32, 199.
- Hanson, N. R. (1961). Is There a Logic in Scientific Discovery? In H. Feigl, & M. Grover (Eds.), *Current Issues in the Philosophy of Science* (pp. 20-35). New York: Holt, Rinehart and Winston.

- Hausman, A., & Stock, J. R. (2003). Adoption and Implementation of Technological Innovations within Long-Term Relationships. *Journal of Business Research*, 56, 681-686.
- Hawrylak, P. J., Mickle, M. H., & Cain, J. T. (2008). RFID Tags. In L. Yan, Y. Zhang, L. T. Yang & H. Ning (Eds.), *The Internet of Things* (pp. 1-32). New York: Auerbach Publications.
- Networked Systems: 1-32. New York: Auerbach Publications, p. 6).
- Heckman, J. J. (1979). Sample Selection Bias as a Specification Error. *Econometrica*, 47(1), 153-161.
- Herbert, W. A. (2006). No Direction Home: Will the Law Keep Pace with Human Tracking Technology to Protect Individual Privacy and Stop Geoslavery? *A Journal of Law and Policy for the Information Society*, 2, 409-473.
- Howells, J., & Wood, M. (1995). Diffusion and Management of Electronic Data Interchange: Barriers and Opportunities in the UK Pharmaceutical and Healthcare Industries. *Technology Analysis Strategic Management*, 7(4), 371-386.
- Hoy, D. C. (1985). Interpreting the Law: Hermeneutical and Poststructuralist Perspectives. *Southern California Law Review*, 58, 135-176.
- Hübner-Fischer, S. (2000). Privacy and Security at Risk in the Global Information Society. In B. Loade (Ed.), *Cybercrime*. London: Routledge.
- Huyskens, C., & Loebbecke, C. (2007). RFID Adoption: Theoretical Concepts and their Practical Application in Fashion. In T. McMaster, D. Wastell, E. Femeley & J. DeGross (Eds.), *IFIP International Federation for Information Processing, Volume 235, Organizational Dynamics of Technology-Based Innovation: Diversifying the Research Agenda* (pp. 345-361). Boston: Springer.
- Iacovou, C. L., Benbasat, I., & Dexter, A. S. (1995). Electronic Data Interchange and Small Organizations: Adoption and Impact of Technology. *MIS Quarterly*, 19(4), 465-485.
- IBM Corporation. (2007). *Vassar Brothers Medical Center Adapts to Healthcare's Challenges through Mobile Processes*. Somers: IBM. Retrieved November 16, 2008, from URL

<ftp://ftp.software.ibm.com/software/solutions/pdfs/ODC00283-USEN-00.pdf>.

- ISO. *ISO International Organisation for Standardisation*. 2008, Retrieved from URL <http://www.iso.org/iso/home.htm>.
- Radio Regulation. (2005).
- James, W. (2004, first printed 1904). The Pragmatic Method. In A. Malachowski (Ed.), *Pragmatism. Volume 1: The Historical Development of Pragmatism* (pp. 135-148). London: SAGE Publications.
- James, W. (2004, first printed 1907). What Pragmatism Means. In A. Malachowski (Ed.), *Pragmatism. Volume 1: The Historical Development of Pragmatism* (pp. 147-161). London: SAGE Publications.
- Jeyaraj, A., Rottman, J. W., & Lacity, M. C. (2006). A Review of the Predictors, Linkages, and Biases in IT Innovation Adoption Research. *Journal of Information Technology*, 21(1), 1-23.
- Jiménez-Martínez, J., & Polo-Redondo, Y. (2001). Key Variables in the EDI Adoption by Retail Firms. *Technovation*, 21, 385-394.
- Johnson, J. M. (2001). In-Depth Interviewing. In J. F. Gubrium, & J. A. Holstein (Eds.), *Handbook of Interview Research - Context & Method* (pp. 103 et seq.). London: Sage.
- Jones, P., Clarke-Hill, C., Comfort, D., Hillier, D., & Shears, P. (2005). Radio Frequency Identification and Food Retailing in the UK. *British Food Journal*, 107(6), 356-360.
- Jones, P., Clarke-Hill, C., Hillier, D., & Comfort, D. (2005). The Benefits, Challenges and Impacts of Radio Frequency Identification Technology (RFID) for Retailers in UK. *Marketing Intelligence & Planning*, 23(4), 395-402.
- Jun, M., & Cai, S. (2003). Key Obstacles to EDI Success: From the US Small Manufacturing Companies' Perspective. *Industrial Management & Data Systems*, 103(3), 192-203.
- Kartiwi, M. (2006). Case Studies of E-Commerce Adoption in Indonesian SMEs: The Evaluation of Strategic Use. *Australian Journal of Information Systems*, 14(1), 69-80.
- Katz v. United States*, 389 U.S. 347 (1967).

- Kern, C. (2006). *Anwendung von RFID-Systemen*. Berlin: Springer.
- Kifer, M., Bernstein, A., & Lewis, P. M. (2006). *Database Systems. An Application-Oriented Approach*. (2nd edition). Boston, Massachusetts: Pearson Addison Wesley.
- Klaus, S. (2007). *De-/Regulierung*. Norderstedt: Books on Demand.
- Kobelev, O. (2005). Big Brother on a Tiny Chip: Ushering in the Age of Global Surveillance Through the Use of Radio Frequency Identification Technology and the Need for Legislative Response. *North Carolina Journal of Law & Technology*, 6(2), 325-342.
- Koh, C. E., Kim, J. H., & Kim, E. Y. (2006). The Impact of RFID in Retail Industry: Issues and Critical Success Factors. *Journal of Shopping Center Research*, 113(1), 101-117.
- Koops, B. (2006). Should ICT Regulation Be Technology-Neutral? In B. Koops, M. Lips, C. Prins & M. Schellekens (Eds.), *Starting Point for ICT Regulation* (pp. 77-108). The Hague: TMC Asser Press.
- Koops, B., & Leenes, R. (2005). 'Code' and the Slow Erosion of Privacy. *Michigan Telecommunications and Technology Law Review*, (12), 115-188.
- Koops, B., Lips, M., Nouwt, S., Prins, C., & Schellekens, M. (2006). Should Self-Regulation be the Starting Point? In B. Koops, M. Lips, C. Prins & M. Schellekens (Eds.), *Starting Points for ICT Regulation* (pp. 109-149). The Hague: TCM Asser Press.
- Kuan, K. K. Y., & Chau, P. Y. K. (2001). A Perception-Based Model for EDI Adoption in Small Businesses Using a Technology-Organization-Environment Framework. *Information & Management*, 38, 507-521.
- Kuhn, T. (1970). *The Structure of Scientific Revolutions* (2nd edition). Chicago: University of Chicago Press.
- Kyllo v. Unites States*, 533 U.S. 29 (2001).
- Lahiri, S. (2006). *RFID Sourcebook*. Upper Saddle River, New Jersey: IBM Press.
- Lai, F., Hutchinson, J., & Zhang, G. (2005). Radio Frequency Identification (RFID) in China: Opportunities and Challenges. *International Journal of Retail & Distribution Management*, 33(12), 905-916.

- Lai, K.-H., Ngai, E. W. T., & Cheng, T. C. E. (2005). Information Technology Adoption in Hong Kong's Logistics Industry. *Transportation Journal*, 44(4), 1-9.
- Lai, K., Wong, C. W. Y., & Cheng, T. C. E. (2006). Institutional Isomorphism and the Adoption of Information Technology for Supply Chain Management. *Computer in Industry*, 57(1), 93-98.
- Landau, S. (2006). Digital Age Communications Law Reform: National Security on the Line. *Journal on Telecommunications & High Technology Law*, 4, 409.
- Landry, M., & Banville, C. (1992). A Disciplined Methodological Pluralism for MIS Research. *Accounting, Management, and Information Technologies*, 2(2), 77-98.
- Lee, G., & Xia, W. (2006). Organizational Size and IT Innovation Adoption: A Meta-Analysis. *Information & Management*, 43, 975.
- Lee, S., & Treacy, M. E. (1988). Information Technology Impacts on Innovation. *R&D Management*, 18(3), 257-271.
- Lessig, L. (1999). The Law of the Horse: What Cyberlaw Might Teach. *Harvard Law Review*, 113, 501-546.
- Lessig, L. (2002). The Architecture of Innovation. *Duke Law Journal*, 51(6), 1783-1801.
- LexisNexis. Retrieved September 29, 2007, from URL <http://www.lexisnexis.com> (license required).
- Lips, M. (2006a). Introduction. In B. Koops, M. Lips, C. Prins & M. Schellekens (Eds.), *Starting Points for ICT Regulation* (pp. 1-11). The Hague: TMC Asser Press.
- Lips, M. (2006b). Inventory of General ICT Regulatory Starting Points. In B. Koops, M. Lips, C. Prins & M. Schellekens (Eds.), *Starting Points for ICT Regulation* (pp. 13-50). The Hague: TMC Asser Press.
- Litan, R. E. (2001). *Law and Policy in the Age of the Internet*. Working Paper 01-04. Washington D.C.: AEI-Brookings Joint Center for Regulatory Studies.
- Mattern, F. Die Technische Basis für das Internet der Dinge. Retrieved April 2006, from URL <http://www.vs.inf.ethz.ch/publ/papers/internetdinge.pdf>.

- Malecki, E. J. (1977). Firms and Innovation Diffusion: Examples from Banking. *Environment and Planning*, 9, 1291-1305.
- Menand, L. (2004). Pragmatism. In A. Malachowski (Ed.), *Pragmatism* (Volume 1, pp. 17-45). London: SAGE Publications.
- met. (18 May 2009). Ein Datenschutzanliegen spaltet die Schweiz. *Neue Zürcher Zeitung*, p. 7.
- METRO Group (Future Store Initiative). (2008). *Spectrum RFID*. Retrieved November 15, 2008, from http://www.future-store.org/fsi-internet/get/documents/FSI/multimedia/pdfs/broschueren/WISSB_Publikationen_Broschueren_SpektrumRFID.pdf;jsessionid=a48b283c30d6b4d6ab2e22cf4f638a02d899af52f729.
- Michelin. (2008). *Michelin Leaps Forward in Tire Electronics*. Retrieved November 14, 2008, from <http://www.michelinmedia.com/pressSingle/value=MCH2006111367776>.
- Mingers, J. (2001). Combining IS Research Methods: Towards a Pluralist Methodology. *Information Systems Research*, 12(3), 240-259.
- Mohanam, K. P. *Paradigms, Theories, Frameworks, Incommensurability, and Theory Ladenness*. Retrieved from URL: <http://courses.nus.edu.sg/course/ellkpmoh/phil0/Kuhn.pdf>.
- Mohr, L. B. (1969). Determinants of Innovation in Organizations. *The American Political Science Review*, 63(1), 111-126.
- Moore, G. C., & Benbasat, I. (1991). Development of an Instrument to Measure the Perception of Adopting an Information Technology Innovation. *Information Systems Research*, 2(3), 191-222.
- Morgan, G. (1980). Paradigms, Metaphors, and Puzzle Solving in Organization Theory. *Administrative Science Quarterly*, Vol. 25(4), 605-622.
- Multispectral Solutions Inc. (2008). *Radio Frequency Identification System Model Sapphire Vision*. Retrieved November 1, 2008, from http://www.multispectral.com/pdf/Sapphire_VISION.pdf
- Nardi, P. M. (2003). *Doing Survey Research - A Guide to Quantitative Methods*. Boston: Pearson Education.
- National Post*. URL: <http://www.canada.com/nationalpost/index.html>.

- The New York Times*. URL: <http://www.nytimes.com/>.
- Ogus, A. (2004). *Regulation: Legal, Form and Economic Theory*. Oxford: Hart Publishing.
- Olmstead v. United States*, 277 U.S. 438 (1928).
- Paavola, S. (2006). On the Origin of Ideas: An Abductivist Approach to Discovery. University of Helsinki, Department of Philosophy. Doctoral Thesis.
- Papastathopoulou, P., Avlonitis, G. J., & Panagopoulos, N. G. (2007). Intraorganizational Information and Communication Technology Diffusion: Implications for Industrial Sellers and Buyers. *Industrial Marketing Management*, 36(3), 322-336.
- Peirce, C. S. (1931-1958). In Harthorne C., Weiss P. (Eds.), *Collected Papers of Charles Sanders Peirce* (Vol. V-VI: Pragmatism and Pragmaticism - Scientific Metaphysics). Cambridge: Harvard University Press.
- Peirce, C. S. (1955). In Buchler J. (Ed.), *Philosophical Writings of Peirce*. New York: Dover Publications.
- Peirce, C. S. (2004, first printed 1878). How to Make Our Ideas Clear. In A. Malachowski (Ed.), *Pragmatism. Volume 1: The Historical Development of Pragmatism* (pp. 62-76). London: SAGE Publications.
- Peirce, C. S. (2004, first printed 1906). Issues of Pragmaticism. In A. Malachowski (Ed.), *Pragmatism. Volume 1: The Historical Development of Pragmatism* (pp. 91-103). London: SAGE Publications.
- Premkumar, G. P., & Roberts, M. (1999). Adoption of New Information Technologies in Rural Small Businesses. *The International Journal of Management Science*, 27(4), 467-484.
- Prins, C. (2006). Should ICT Regulation Be Undertaken at an International Level? In B. Koops, M. Lips, C. Prins & M. Schellekens (Eds.), *Starting Points for ICT Regulation* (pp. 151-201). The Hague: TCM Asser Press.
- Prosser, T. (1986). *Nationalised Industry and Public Control: Legal, Constitutional and Political Issues*. Oxford: Blackwell.
- Prosser, T. (2006). Regulation and Social Solidarity. *Journal of Law and Society*, 33(3), 364.

- Ramakrishnan, R., & Gehrke, J. (2000). *Database Management Systems* (2nd edition). Boston, Massachusetts: Mc Graw Hill.
- Rasmussen, L. B., Henschel, R. F., & Sol, H. G. (2009). *Evaluation of "When Bits Learn to Walk Don't Make Them Trip" Ph.D. Thesis Submitted for the Ph.D. Degree by Daniel Ronzani*. Unpublished letter.
- Rasmussen, E. S., Oestergaard, P., & Beckmann, S. C. (2006). *Social Science Research Methodology (Essentials of)*. Odense: University Press of Southern Denmark.
- Rea, L. M., & Parker, R. A. (2005). *Designing & Conducting Survey Research - A Comprehensive Guide* (3rd edition). San Francisco: Jossey-Bass.
- Reding, V. (2006). *RFID: Why We Need a European Policy*. SPEECH/06/597. Brussels.
- RF Code Inc. (2008). *M100 Active RFID Tag*. Retrieved November 1, 2008, from URL http://www.rfcode.com/images/tech_spec_sheets/m100_tech_spec_sheet.pdf.
- RFID Inc. (2008). *Extend-a-Read Datasheet*. Retrieved November 1, 2008, from URL <http://www.rfidinc.com/extend.html>.
- RFID Journal. URL: <http://www.rfidjournal.com> (partial subscriber webpage).
- RFind. (2008). *RFind Answering the Question "Where?" - Affordable RTLS*. Retrieved November 1, 2008, from URL http://www.rfind.com/pdf/RFind%20Tags%20Gateway%20_V1.5_%2005-01-07.pdf.
- Rodi, M. (2008). Innovationsförderung durch Instrumente der Umweltpolitik. In M. Eifert, & W. Hoffmann-Riem (Eds.), *Innovationsfördernde Regulierung* (pp. 147-195). Berlin: Duncker & Humblot.
- Rogers, E. M. (2003). *Diffusion of Innovation* (5th edition). New York: Free Press.
- Ronzani, D. (2007). Absence of Legal Database Protection in the EPCglobal Network. *International Journal for Intellectual Property Management*, 1(4), 341-350.

- Ronzani, D. (2008a). Modality Mix of RFID Regulation. *Journal of International Commercial Law and Technology*, 3(4), 222-232.
- Ronzani, D. (2008b). Why Marketing Short Range Devices as Active Radio Frequency Identifiers Might Backfire. *The Internet of Things*, Zurich. LNCS 4952, 214-229.
- Ronzani, D. (2009a). The Battle of Concepts: Ubiquitous Computing, Pervasive Computing and Ambient Intelligence in Mass Media. *Ubiquitous Computing and Communication Journal*, 4(2), 1-11.
- Ronzani, D. (2009b). Legal Regulation and Consumers: The RFID Industry's Perspective. A variation of this manuscript to be submitted for review as book chapter.
- Rothensee, M., & Spiekermann, S. (2008). Between Extreme Rejection and Cautious Acceptance - Consumers' Reactions to RFID-Based IS in Retail. *Social Science Computer Review*, 26(1), 75-86.
- Santrock, J. W. (2008). In Ryan M. (Ed.), *A Topical Approach to Lifespan Development* (4th edition). New York: McGraw-Hill.
- Savi Technology Inc. (2008). *SaviTag ST-656 ISO Container Door Tag*. Retrieved November 1, 2008, from URL http://www.savi.com/products/SaviTag_656.pdf.
- Schaeffer, N. C., & Presser, S. (2005). The Science of Asking Questions. Volume II: Data Quality. In J. Scott, & Y. Xie (Eds.), *Quantitative Social Science* (pp. 3-31). London: Sage Publications.
- Schellekens, M. (2006). What Holds Off-Line, Also Hold On-Line? In B. Koops, M. Lips, C. Prins & M. Schellekens (Eds.), *Starting Points for ICT* (pp. 51-75). The Hague: TMC Asser Press.
- Schellekens, M., Koops, B., & Prins, C. (2006). Conclusion. In B. Koops, M. Lips, C. Prins & M. Schellekens (Eds.), *Starting Points for ICT Regulation* (pp. 229-238). The Hague: TMC Asser Press.
- Schmitt, P. (2008). Adoption und Diffusion neuer Technologien am Beispiel der Radiofrequenz-Identifikation (RFID). Doktor der Wissenschaften der ETH Zürich, Eidgenössische Technische Hochschule. Doctoral Thesis.

- Schmitt, P., Michahelles, F., & Fleisch, E. (2008). Why RFID Adoption and Diffusion Takes Time: The Role of Standards in the Automotive Industry. *Auto-ID Lab*.
- Schweizerische Eidgenossenschaft. (2009a). *Abstimmung: Reisefreiheit und Sicherheit*. Retrieved May 30, 2009, from URL <http://www.schweizerpass.admin.ch/pass/de/home/aktuell/abstimmungen.html>.
- Schweizerische Eidgenossenschaft. (2009b). Volksabstimmung vom 17. Mai 2009: Erläuterungen des Bundesrates.
- Scott, C. (2004). Regulatory Innovation and the Online Consumer. *Law & Policy*, 26(3 & 4), 477-506.
- Seyal, A., Rahman, A. M. N., & Mohammad, H. A. Y. H. A. (2007). A Quantitative Analysis of Factors Contributing Electronic Data Interchange Adoption Among Bruneian SMEs. *Business Process Management Journal*, 13(5), 728-746.
- Seymour, L., Lambert-Porter, E., & Willuweit, L. (2007). RFID Adoption into the Container Supply Chain: Proposing a Framework. *6th Annual ISOnEworld Conference*, Las Vegas, NV. 55-0-55-14.
- Shank, G. (1989). Qualitative versus Quantitative Research: A Semiotic Non Problem. *Semiotics (for Publication in)*.
- Shank, G. (1998). The Extraordinary Ordinary Powers of Abductive Reasoning. *Theory & Psychology*, 8(6), 841-860.
- Shank, G., & Cunningham, D. J. (1996). Modeling the Six Modes of Peircean Abduction for Educational Purposes. *Annual Meeting of the Midwest AI and Cognitive Science Conference, MAICS 1996 Proceedings*.
- Shao, Y. P. (1999). Expert Systems Diffusion in British Banking: Diffusion Models and Media Factor. *Information & Management*, 35(1), 1-8.
- Sharma, A., Citurs, A., & Konsynski, B. (2007). Strategic and Institutional Perspectives in the Adoption and Early Integration of Radio Frequency Identification (RFID). *Proceedings of the 40th Hawaii International Conference on System Sciences (HICSS'07)*.

- Sharma, A., Thomas, D., & Konsynski, B. (2008). Strategic and Institutional Perspectives in the Evaluation, Adoption and Early Integration of Radio Frequency Identification (RFID): An Empirical Investigation of Current and Potential Adopters. *Proceedings of the 41st Hawaii International Conference on System Sciences (HICSS'08)*.
- Sherman, B. (1988). Hermeneutics in Law. *The Modern Law Review*, 51(3), 386-402.
- Smith, S. L. (2006). Symposium Review: RFID and other Embedded Technologies: Who Owns the Data? *Santa Clara Computer and High Technology Law Journal*, 22, 695 et seq.
- Smith, S. L. (2007). Gone in a Blink: The Overlooked Privacy Problems Caused by Contactless Payment Systems. *Marquette Intellectual Property Law Review*, 11, 213 et seq.
- Sood, P. (2007). *The Physics Behind RFID*. Unpublished manuscript. Retrieved June 4, 2008, from URL http://www.rfidjournalevents.com/liveeurope2007/pdfs/Nov6_University_13-15_physicsBehindRFID.pdf (restricted website).
- Souder, W. F. (1977). Effectiveness of Nominal and Interacting Group Decision Processes for Interacting R & D and Marketing. *Management Science*, 23(6), 595-605.
- Spivak, S. M., & Brenner, F. C. (2001). *Standardization Essentials: Principles and Practice*. New York: Marcel Dekker.
- Stark, S. C., & Nagle, E. P. (2004). Full Speed Ahead with DOD Identification Requirements: Next Stop, Radio Frequency Identification. *Procurement Lawyer*, 40-Fall, 11 et seq.
- Stein, S. G. (2007). Where Will Consumers Find Privacy Protection from RFID?: A Case for Federal Legislation. *Duke Law & Technology Review*, 3, 1-22.
- Stick, J. (1986). Can Nihilism be Pragmatic? *Harvard Law Review*, 100, 332 et seq.
- Strickland, L. S., & Hunt, L. E. (2005). Technology, Security, and Individual Privacy: New Tools, New Threats, and New Public Perceptions. *Journal of the American Society for Information Science and Technology*, 56(3), pp. 221-234.

- Sunstein, C. (1990). *After the Rights Revolution: Reconceiving the Regulatory State*. Cambridge (MA): Harvard University Press.
- Swanson, E. B. (1994). Information Systems Innovation among Organizations. *Management Science*, 40(9), 1069-1092.
- Synometrix Integrated Technologies. (2008). *SYNOtag Active*. Retrieved November 1, 2008, from URL http://www.synometrix.com/SYNOMETRIX_SMPTK-002_active_RFID_tag_specification.pdf.
- Tajima, M. (2007). Strategic Value of RFID in Supply Chain Management. *Journal of Purchasing and Supply Management*, 13, 261-273.
- Tanewski, G., Collier, P. A., & Leech, S. A. (2003). Achieving Strategic Benefits from B2B eCommerce: A Multiple Case Study of the Australian Automobile Industry. *16th Bled eCommerce Conference eTransformation*, pp. 214-248.
- Taylor, S., & Todd, P. (1995). Assessing IT Usage: The Role of Prior Experience. *MIS Quarterly*, 19(4), 561-570.
- Terry, N. P. (2005). Assessing the Technical, Conceptual, and Legal Frameworks for Patient Safety Information. *Widener Law Review*, 12, 133.
- Teubner, G. (Ed.). (1986). *Dilemmas of Law in the Welfare State*. Berlin: Walter de Gruyter.
- Thompson, D., Kot, K., & Brothers, J. (2005). Radio Frequency Identification: Legal Aspects. *Richmond Journal of Law and Technology*, 12, 6.
- Thompson, R. L., Higgins, C. A., & Howell, J. M. (1991). Personal Computing: Toward a Conceptual Model of Utilization. *MIS Quarterly*, 15(1), 124-143.
- Thong, J. Y. L., Yap, C., & Raman, K. S. (1996). Top Management Support, External Expertise and Information Systems Implementation in Small Businesses. *Information Systems Research*, 7(2), 248-267.
- The Times Online*. URL: <http://www.timesonline.co.uk/global/>.
- Tornatzky, L. G., & Fleischer, M. (1990). *The Process of Technological Innovation*. Lexington, Mass.: Lexington Books.

- Tornatzky, L. G., & Klein, K. J. (1982). Innovation Characteristics and Innovation Adoption-Implementation: A Meta-Analysis of Findings. *IEEE Transactions on Engineering Management*, 29(1), 28-45.
- Toronto Star*. URL: <http://www.thestar.com>.
- Tushman, M. L., & Nelson, R. R. (1990). Introduction: Technology, Organizations, and Innovation. *Administrative Science Quarterly*, 35, 1-8.
- Ubisense Ltd. (2008). *Ubisense Compact Tag Fact Sheet*. Retrieved November 1, 2008, from URL <http://www.ubisense.net/media/pdf/Ubisense%20Compact%20Tag%20EN%20V1.0.pdf>.
- Uddin, K. M. (2006). The Role of Diffusion of Innovations for Incremental Development in Small Enterprises. *Technovation*, 26(2), 274-284.
- United States v. Knotts*, 460 U.S. 276 (1983).
- Van de Voort, M., & Ligtvoet, A. (2006). *Towards an RFID Policy for Europe* (Prepared for the European Commission, Directorate General Information Society and Media No. DRR-4046-EC).
- van der Hof, S., & Stuurman, K. (2006). Code as Law? In B. Koops, M. Lips, C. Prins & M. Schellekens (Eds.), *Starting Points for ICT Regulation* (pp. 203-227). The Hague: TMC Asser Press.
- Venkatesh, V., Morris, M. G., Davis, G. B., & Davis, F. D. (2003). User Acceptance of Information Technology: Toward a Unified View. *MIS Quarterly*, 27(3), 425-478.
- Venkatesh, V., & Davis, F. D. (2000). A Theoretical Extension of the Technology Acceptance Model: Four Longitudinal Field Studies. *Management Science*, 46(2), 186-204.
- Vijayaraman, B. S., & Osyk, A. (2006). An Empirical Study of RFID Implementation in the Warehousing Industry. *International Journal of Logistics Management*, 17(1), 6-20.
- Vijayasathya, L. R., & Tyler, M. L. (1997). Adoption Factors and Electronic Data Interchange Use: A Survey of Retail Companies. *International Journal of Retail & Distribution Management*, 25(9), 286-292.

- Vita Craft Corporation. (2008). *Robotic Cookware*. Retrieved November 14, 2008, from URL <http://www.vitacraft.com/rfiq/home.html>.
- Vogt, W. P. (2007). *Quantitative Research Methods for Professionals*. Boston: Pearson Education.
- von Bertalanffy, L. (1971). *General System Theory: Foundations, Development, Applications*. Middlesex, England: Allen Lane The Penguin Press.
- The Wall Street Journal Online*. URL <http://online.wsj.com/public/us>.
- The Washington Post*. URL <http://www.washingtonpost.com/>.
- Weber, M. M., & Kantamneni, S. P. (2002). POS and EDI in Retailing: An Examination of the Benefits und Barriers. *Supply Chain Management: An International Journal*, 7(5), 311-317.
- Westlaw. URL: <http://www.westlaw.com> (subscriber webpage).
- Wherenet (a Zebra Technologies Company). (2008). *Where Tag III - Ideal for Indoor or Outdoor Asset Tracking*. Retrieved November 1, 2008, from URL <http://www.wherenet.com/pdf/products/WhereTagIII.6.14.07.pdf>.
- Whitaker, J., Mithas, S., & Krishnan, M. S. (2007). A Field Study of RFID Deployment and Return Expectations. *Production & Operations Management*, 16(5), 599-612.
- Willingham, K. M. (2007). Scanning Legislative Efforts: Current RFID Legislation Suffers from Misguided Fears. *North Carolina Banking Institute*, 11, 313.
- Wolfe, R. A. (1994). Organizational Innovation: Review, Critique and Suggested Research Directions. *Journal of Management Studies*, 31(3), 405-431.
- Wu, J. (2008). In ZIK, Zentrum für Informations- und Kommunikationsrecht (Ed.), *Telecommunications Competition and its Driving Forces*. Zürich: Schulthess.
- Wu, N. C., Nystrom, T. R., Lin, T. R., & Yu, H. C. (2006). Challenges to Global RFID Adoption. *Technology Analysis & Strategic Management*, 26, 1317-1323.

- Wyld, D. C., Jones, M. A., & Totten, J. W. (2005). Where is my Suitcase? RFID and Airline Customer Service. *Marketing Intelligence & Planning*, 23(4), 382-394.
- Yin, R. K. (2003). *Case Study Research* (3rd edition). Thousand Oaks: Sage Publications.
- Zmud, R. W. (1983). The Effectiveness of External Information Channels in Facilitating Innovation within Software Development Groups. *MIS Quarterly*, 7(2), 43-58.

Appendix 1

Excerpt of Coding Sheet for Concept Article

Research Tool: NVIVO 7 by QSR (student license)

Excerpt of nodes defined in NVIVO 7. The check mark “✓” indicates that an attribute is found and used in the concept.

Date	Newspaper	Concept	Attributes					
			anywhere any time	home leisure	business work	networks	sensor	intelligent smart
12/03 /2003	Financial Times	pervasive computing		✓				
02/04 /2003	Financial Times	pervasive computing				✓		
14/04 /2003	Toronto Star	ubiquitous computing					✓	
05/08 /2003	Financial Times	ubiquitous computing			✓			✓
11/10 /2003	National Post	ambient intelligence						✓
26/11 /2003	Financial Times	pervasive computing	✓			✓		
21/01 /2004	Financial Times	pervasive computing				✓		✓
25/03 /2004	Guardian	ubiquitous computing	✓				✓	✓
06/05 /2004	N.Y. Times	ubiquitous computing		✓				✓
20/05 /2004	N.Y. Times	ambient intelligence					✓	✓
19/08 /2004	Guardian	ubiquitous computing					✓	

[continued on next page]

Date	Newspaper	Concept	Attributes					
			anywhere any time	home leisure	business work	networks	sensor	intelligent smart
21/10 /2004	Guardian	pervasive computing					✓	✓
18/11 /2004	Washingt on Post	pervasive computing				✓	✓	✓
12/03 /2005	Financial Times	pervasive computing	✓	✓	✓			
20/05 /2005	Financial Times	ubiquitous computing				✓	✓	
15/06 /2005	Financial Times	pervasive computing		✓				
27/07 /2005	Financial Times	ubiquitous computing				✓		
29/08 /2005	N.Y. Times	pervasive computing				✓	✓	
25/01 /2006	Financial Times	ubiquitous computing	✓					

Appendix 2

Interview Template

(Summary of Several Interviews)

Interview structure

1. General questions
2. Frequency
3. Database
4. Privacy

1. General

- How do you position your company within the RFID space and the services you receive, use, and pass on?
- What was the main motivation to deploy RFID? Positive business case? Has your goal changed since the business case?
- Did your company follow all 5 stages: Business case, proof of concept, pilot, initial implementation and full roll-out?
- Where in the four phases of BC, POC, pilot and implementation did you realize / discuss the legal regulation issues?
- Do you have specific regulation problems with RFID deployment in certain countries?
 - Yes, what kind;
 - No, why do believe not?
- What is currently the relation between pallet and item-level tagging in your company (expressed in %)?
- What tags do you use/deploy mostly at present time (passive or active tags)?
- Which industry players are in your opinion most concerned with statutory provisions?
- How is the knowledge about RFID legal requirements acquired? Is this a discussion topic with your customers?

- How concerned are customers with RFID regulation, maybe in percentage as compared to business case you discuss?
- Can you recall or describe incidents that arose with customers based on legal RFID issues?
- Do you have the feeling that the deployment of RFID is inhibited by law or policy makers?
- What is your definition of active tag: reacts only with reader v. sends signal autonomously?

2. Radio Frequency Spectrum

- The European Commission has harmonised the UHF spectrum for passive tags in Europe (harmonise availability/efficiency of use). How do you perceive frequency in general in deployment of RFID?
- How do you evaluate the RFID spectrum in cross continental deployments based on the 3-region allocation of the International Telecommunications Union (radio regulations)?
- How do you believe would the market grow more significantly: with more or with less frequency spectrum?
- Have you experienced or discussed with customers the certification problems for frequency allocation?

3. Database

- USA and EU have different DB legislation. US is based mainly on copyright whereas the EU has *sui generis* law to protect DBs. In international projects, do you perceive an advantage or disadvantage in RFID deployment based on the different DB regimes?
- The EC analysed in a survey that openness and neutrality of DB are a concern. Where and how do clients currently store the RFID data? Are they aware of the DB regulations?
- Is the difference between open and closed environment an issue with customers?

- When deploying the DB directive in Europe it was one goal of the EC to foster Europe as attractive region for DBs. Given the large amount of data that RFID will potentially produce, do you think customers could elect Europe over US as place for RFID DB?

4. Privacy

- The European Data Protection Supervisor (EDPS) has proposed in its opinion to the European Commission a Community legislation regulating RFID if existing legal framework fails. Irrespective of the content of such legal framework, do you
 - favour such approach even if it takes long time (several years) to put into force?
 - disfavour such an approach because technology/business efforts might become “illegal” with such future laws?
- How do you see the potential of having the data directly on the tag rather than in a backbone DB system?
- How do you perceive the privacy debates for either pallet or item-level tagging?
- The EDPS has stipulated in its opinion to the EC that there is a lack of transparency in RFID use. How could this issue be solved in deployment?
- Are you personally concerned about privacy issues in RFID tags?

Appendix 3A

Excerpt of 1st Interview Transcript with Company A

Interview date: Wednesday, March 12, 2008

Time: 10.00am - 11.05am

Interview type: Telephone interview, recorded as MP3 file via PC in room 253 at IBM Research GmbH, Säumerstrasse 4, 8803 Rüschlikon, Switzerland

Transcript: 8'605 words (of which 4'405 are reprinted in this Appendix)

DR = Daniel Ronzani (interviewer and transcriber)

A = Global leader sensors and actuators at Company A (interviewee).
Company A is an RFID integrator.

[...]

DR: If you look at your customers, how would you describe the RFID services that the customers are seeking today from Company A? How would you describe the market?

A: There are multiple levels. Let me start at the top level. And then this will lead also into what type of services they are looking for, and what they are focusing on. First off, there are different engagement phases that you can see from an RFID perspective. We have documented this quite well. I would say four phases that come out very clearly are

- the business case phase. That is where you see a company having a lot of interest in the RFID space and deciding, well, let's examine what processes we could use RFID in, build the business case, and see if it would be worth the investment. So that's one phase;

- the second phase is what we call the proof of concept. And that is where people who are interested in RFID want to test out the equipment, test out the infrastructure, look at the read rates, look at the interference. If you have multiple dock doors. So you are really validating if the technology works in your environment;
- the third phase would be actually the pilot, which would be “OK, I found the technology works, but now I validate the business processes”. And I want to validate my business case that I had created earlier. So it's not a technology focus. It's more on using the technology that works and validating that it works in your environment in terms of the business processes and that it actually adds business value;
- the fourth phase, and this could be combined with the fifth phase, the fourth phase would be an initial implementation. So, rather than doing an all out implementation you would see some customers focusing maybe on one warehouse. And maybe installing 20 readers. And doing an initial implementation; and then
- finally, the fifth phase, would be a full roll-out throughout the environment.

Now if you look at those 4-5 phases, some companies have skipped the business case. They've gone straight to doing a proof of concept. Some companies do what they call a pilot what is really a proof of concept. But I would say the majority of companies have started with a proof of concept. Today's environment is such that most companies that have done anything with RFID have already done a proof of concept, or are still doing a proof of concept. However, they are starting to move – some of them, the early adopters – have already moved into the pilot phase and are validating their business processes. And you have seen some further adopters, like Company X in Y, that have gone beyond pilot and are going into an initial deployment. And I would say somewhere between the initial deployment and full deployment because they are doing

multiple warehouses. However, as it stands today, we are still very much at pilot phase, with a few implementations.

Now this also varies per industry. So we have seen examples in the automotive industry that a lot of stuff is happening at pallet level. In terms of, for instance, tracking containers. And I have been very focused on this. So you have companies like Company X, Company Y, and Company Z that have all done or are doing pilots with us for container tracking. But also in the auto industry you have seen that they have actually had implementations, not just pilots, implementations of tracking cars in lots. Retail you see lots happening. They are already into implementations. OK? So it varies per industry. And I do not want to get into every specific industry. But I would say the maturity level varies per industry.

If we look specifically at the application areas, what got all of the press during the last two years is very much supply chain oriented. Tagging cases and pallets. And I am talking very much about Europe here; all about Europe. And Company B is a good example of this. But what we saw also is that companies had looked initially at tagging cases and pallets were now moving instead towards tagging these things called “return transport items” (RTI). So these are the raw cages, you put the goods in. And tracking those for 2 reasons:

- they are very valuable in itself, so it is an asset tracking application there; and
- it is a supply chain management perspective because you are tracking what is in it.

So what we have seen from an application perspective, supply chain management got all of the press two years ago. But lately much of the press and much of the activity actually is in asset tracking. So whether it is tracking containers in the automobile industry or tracking containers or RTI what they call them in the retail industry or tracking assets in your building or tracking people on an oil rig, you see this application area getting much more interest. There are a couple of reasons:

- it is an easier business case and more visible because it is easier to build a business case on tracking an asset because it has got some value.
- many of these asset tracking applications are within 4 walls.

So because it takes them a lot longer in implementation time and agreement between supply chain partners to roll-out RFID in the supply chain – so it is longer term. While asset tracking can be within the 4 walls.

DR: So you mean a close environment?

A: Yes, close-loop system within the 4 walls. Exactly.

So it is much easier to find the business case. Much easier to make quicker decisions because you do not have multiple players. OK? So you see this area in asset tracking really taking off. So I would say there is another application area which is linked with supply chain but it is slightly different. It is called, it is traceability. Traceability of food, traceability of drugs. And there we actually have a challenge in Europe. Food traceability is a big issue in the EU and RFID has been identified as one area that could help. [...] But traceability, when people talk about traceability, it is the drug manufacturers in the pharmaceutical industry that have all the attention. They have moved much further ahead in the US. In Europe it is very different here. We have many different regulatory frameworks in each country on how drugs are labelled and how drugs are shipped. So that creates, there is no one common standard. So it creates some inhibitors to broader action. Second we have another technology which is 2-dimensional barcode which although it is not as good as RFID it is a lot more cost effective. And it serves some of the existing needs they have today.

The situation varies per industry, is one key point, and I pointed out the key industries. The second thing is that there are multiple application areas, and I mentioned supply chain management, I mentioned asset tracking and I mentioned traceability. The one application area that has had much of the publicity has been supply chain management, specifically in the

retail area. But the one application area that we see growing faster because of strong ROI story is the asset tracking area in close-loop or 4-walls environment.

Some are not doing the business cases. They jump into a POC or they say they do the business case internally and we never see that.

DR: If and when you discuss with customers in what, in which of these 4 phases, if at all, do you talk about RFID regulation and what is allowed and what is not allowed? Can you point and say, well, we do it in the business case. We discuss it there, or we do not discuss it at all, or do you only realize at the initial implementation that we have a problem.

A: Yes, good point. Because of regulation, as correctly said, much of the focus lately has been on privacy. But previous focus, before privacy, was on frequency allocation. But that has changed. So for example, 2 years ago, even though the EU had a harmonized RFID frequency between 865 and 868. Even though they had harmonized that, it still takes, of even the EU had proposed that, it still takes time for them to harmonise it through-out the different countries. So 2 years ago, even though the EU regulation or proposal was there, you still had countries like Italy and Spain that had not freed up that frequency because it was used by the military. So discussions then that we had were an issue: we had to get a specific site license to do a pilot. So if we wanted to run a pilot with an EPC-oriented tag or UHF tag specifically we had to get a license. So that actually had, that had helped break the market; to slow down the market in places like Italy. Two things happened there: a) it did not accelerate as quickly as it should have, there; and b) they started looking at other technologies, high frequency instead.

That was, I would say, some of the discussion we had, this was with the customer. If we were going to do a POC [proof of concept], was that we had to, we were doing, getting a site license, so we could do a specific pilot. The second thing, we had to look, because of the regulation, we had to look at

potentially using an alternate frequency, like HF. But now, a lot of the discussion has now transferred over to... OK, well no, sorry, the frequency was an issue. The other issue that you had also, was power output of your readers and implementing something called “listen before talk”, so you would not have multiple readers going on at once and frequency interference. And I’ll be honest, I am not an expert on this, but I know the Europeans had proposed “listen before talk” and we are now moving away from that. There were some other issue in terms of how many readers you could set up, and how much power they could emit, and at what frequency they could emit this power. That discussion, I think, we are starting to move away from. For 2 reasons:

- the regulation has been loosened up or it is moving away from something that is called “listen before talk”; and
- the manufacturers, the vendor manufacturers found ingenuitive ways to engineer solution that would help address that.

So I think we started to move away from that. And more now move into the regulatory issue which is privacy. [...] Today we are not tagging at item level yet. So it is really not touching the consumer in any way today, at all. So I think it is good we start to raise this discussion and we need to start to set a framework. But in actual fact there are no – or only very few, if any, maybe there are a couple of – pilots at item level but it is not really touching the consumer today.

DR: So there is no discussion with the customer about privacy yet.

A: No.

DR: [Because you] are looking at pallet level.

A: Well, exactly. When we have done the pallet level and the case level and the tracking these returnable transport items there is not the privacy issue at that level because it is not touching the consumer domain. However, in our engagements, when we help a company establish an RFID strategy, of course, we have an offering and we say, we start, we make sure we let the

company know that we need to address the privacy concern so that we can have an offer. So we always inform the customer that we need to make sure that when you are doing RFID implementation, that you also address any potential privacy concerns about your partners, your employees, or your final customers.

With any new technology we always have to explore if there are issues. So I think this is really positive that it *is* in the spotlight. But I think a key point that you made before is that are the regulatory bodies working at cross-purposes or have a totally different goal in mind than the vendors and the people who want to implement it. And here is my ultimate goal: In terms of a regulatory infrastructure, and I am probably getting ahead of a question, but I want to state that right now, is that in terms of a regulatory infrastructure for RFID there are a couple of point I want to make:

1. We should look at existing regulations that we have for consumers in areas like telecommunications, in areas like use of smartcards and bank cards, and things like that to see if we have already a common framework, that covers the RFID space, rather than developing an entirely new regulatory framework. Because if we have some new technology developed every time... if we develop a new framework for every new technology this is ridiculous. So we should at least examine, do we have a current regulatory framework that supports and helps regulate the RFID space.
2. If it does to 80%, then great use that regulatory framework. Be consistent. But then, if there are any specifics, new issues that are not covered because RFID is unique in some ways, let's look at adding some of those regulatory frameworks. That is the second thing.
3. The third [point] is that it must be a balance between the benefits offered by this and the, I would say, the risk of privacy for example. You may have everything as a benefit.

We need to balance the benefits v. what some people would say privacy intrusion.

So I think it is the [retailers] duty to very much make sure that a) consumers are very well informed if RFID is being used, and b) in some cases you need to mandate it that it is automatically disabled. Now the industry says “no, we don’t want that” because of the whole after-sale thing. It is a fine line here. And it would be different from industry to industry. But I think the key part is you need to *inform* the public. This is the key thing. Now, the question is, do you give the customer a choice or do you automatically do it for them? And you are going to have different camps: The economic camp and political camp. So it is a balance. And I think the opinion will vary depending on which perspective you are taking. And they are going to have to reach common ground.

DR: And who is doing a better lobbying at the moment?

A: That verdict is still out. I would say on the vendor’s side because they have more to lose. The vendor’s side and then the retailer’s side, the guys that are pushing, I would say, are lobbying more but they are lobbying against government proposal. So it is a question of who is stronger. And I think there is no black or white. There is no one answer here. It is going to be a balance between the economic benefit and the risk of opening up some privacy issues. And we are going to have to find the right balance.

A couple of key points, then, if I summarise on the privacy issue:

- Lets look for existing, let’s try and use an existing framework that we have that covers various areas, such as communication, bank cards.
- Secondly, if there is a delta, because the RFID technology poses some new challenges and new issues, then of course we need to examine additional legislation

- Third, let's try and align the economic goals together with the privacy and the protection goals. And again, it is going to be a balance there.

The EU needs to be more competitive. So if you lift this up at a high political level, if the EU does not start or does not embrace new technologies, such as RFID to help make streamline their economy, they will not be as competitive as North Americans or as Chinese or as the Indians. So they are positive to use new technology. But they are also much further ahead than most regions in the world in terms of protecting their public. So they are going to look for a balance. A message always comes "oh, you know, Europe is always breaking technology". Well some of the greatest technology comes from Europe. But unfortunately, because you have regulation that is stronger here than in the US, regulation somewhat stifles innovation. But maybe that is, that is what we have to live with if we want to balance the economic benefit v. the privacy concerns. I mean, what do we want: do we want a purely innovative society where people are exposed? Or do we want a somewhat innovative society where people are fairly protected. Again, that is a balance. It is a compromise.

DR: You mentioned competition and also the competition of Europe v. maybe US and AP. A few years ago the EU enacted the database law for Europe which is a little bit different than what we have in the US because in Europe the DB can be protected just because it is a DB. In the US you follow copyright to protect the DB, meaning that whatever goes into the DB needs to be somewhat original otherwise it is not copyrightable. So one goal of the EU at that time was to have such a law in order to put Europe, in the world market a little bit ahead with regards to DB. And if I look at all the data that will be gathered in RFIDs in the future, obviously the DBs will play a big role. And here I would be interested in your opinion with regard to DB, do you see any difference in your negotiations or in your discussion with customers, or are the customer aware even of the difference between any DB regimes here in Europe and the US that would give them an advantage if they had their RFID system in Europe

as compared to the US. Or is this a debate that does not take place at all?

A: Firstly, the real value of RFID really comes in the supply chain when we have sharing of data between partners. And we are still not very much there. I mean, even in supply chain it is still very much the retailer that holds that information. And the data that is in the DB is not consumer-oriented. It's at case and pallet level and it is supply chain-oriented. However, when RFID starts to adopt across the supply chain from the manufacturer all the way down to the retailer and onto shop floor, you are going to have a lot of data sharing. And you are going to have multiple DBs. And we actually have a product called EPCIS, an RFID information server, which is really about holding data. But again, this data, is supply chain-oriented. It is not, it is not at the end customer. However, when we do see RFID being used at item level, data being stored there, it's all about the following: it's about tying that data of transactions to customer data. And there are stiff rules in that, about that in Europe. So there are two types of data: 1) the data in terms of, for example, the item, and the movement of that item; and 2) the data are actually, for example someone's VISA card and transaction information if you did not use cash. And it would be about time those two pieces stated together, and that is a lot about the issue right there. People that are very concerned they do not want to have a retail store being able to tie someone's credit card information to their names and dates... and you can find out a lot of stuff together with the data about another purchase. Because once you tie those 2 pieces of information together, you can do active marketing. And that would mean infringing on somebody's privacy. We are not there yet. We need... we should be taking that discussion now but I for example a good example in Norway, and again, here is where you should benchmark, potentially, the use of loyalty cards because this will help. I am trying to give you some ideas on how to benchmark because you should look elsewhere. Loyalty cards, for instance, I do not know if you have them in Switzerland, but I mean loyalty cards really originated out of the US. And what it was, basically, is if you are a frequent customer to a retail store, that you would be

rewarded by getting discounts or access to special promotions if you were shopping there all the time. And how they did this was through a loyalty card. So very time you bought something you may get points to your loyalty card, for example. And you could redeem those points.

[...]

DR: Do you think that technology/business and law are following diametrical goals?

A: If they are following different goals? Like if the vendors and proponents of RFID are following different goals? Yes, I would say they are following the same goals in one way. I think from the side of the resellers and the vendors they are following an economic goal because for them it is to streamline their supply chain, it's to enable them to get close to the customer, there are a number of benefits from RFID for them. But it's all economic. From the regulatory perspective, it is two-fold:

- Their goal is really to protect society, privacy is one but also from power emissions or things like that. So there is definitely protection of society.
- But then the 2nd goal is exactly the same as the retailers and the vendors. They want to make this society much more commercially competitive to countries like the US and China and India. So they definitely have a commercial goal in mind. They want to use technology to improve the life of people to make Europe more competitive. I would say that is not a cross-purpose. [The EU] wants to be more competitive. They have to be. Because if they are not competitive people are going to lose jobs. And RFID is going to help us be more competitive. It is going to help make daily life easier. We are not cross-purposes.

From my perspective I would say the EU has an *additional* goal. I mean to be honest, the vendors and suppliers and retailers can say “yes, of course we care about society”. But that is much more of a political message. The bottom line is that they are doing this from an economic perspective. [...] It is to say “how

can we assure that balance between regulation and how it can be used in our society to make it more competitive.

DR: Well, if this is the goal, then the chance that we reasonable legislation on RFID is quite high. I would assume.

A: Yes, I think so. This is why I am convinced we are going to have good regulation.

DR: You mentioned earlier that in the radio frequency spectrum area the regulation was a little bit of an inhibitor.

A: Yes.

DR: So you would say that, well, it could be an inhibitor in certain areas but altogether if I look at the big picture, is the assumption then correct that you say “yes, we need regulation even if there are some drawbacks”?

A: Yes, from a societal perspective, and society means economic, political, social, we need it because we *have* to ensure protection of our society. But at the same time we need to balance it on the economic benefits. And therefore I think the approach or involving citizens and companies and the public and the private sector in a negotiation and at the series of workshops they are holding, I think that is really positive. It is not an exclusionary process where big brother just said “no, this is the way it is going to be, without consulting you”.

I think it is up to us in the industry, and I say Company A and the retailers, to give some very very very good reasons from our side. But also be [aware] that we are going to have to compromise to make sure that we can achieve both goals which is economic as well as social.

A: The reason we are not at item level right now is not that it is being inhibited by regulation today. It is being inhibited by the cost of the tag and the business case. But let's not get into a situation where we wait to define this framework where 3-4 years down the road the cost is there. Because then we would spend maybe another year or two talking about it when the cost and the technology is ready. It is good that we are preparing for this right now. But we are still not there yet.

DR: You are talking about how many years?

A: It will vary, for example and this important that you note: If you look at item-level tagging, many years away in the grocery segment. However, it is getting a lot closer, only a few years away in apparel like clothing and shoes and jewellery and areas like that because we have a lot pilot activity there at item level today.

That is coming soon. Definitely. It could be 2-3 years. Because the business case is there. If you look at Company X, they started tagging their [goods], there high ticket items, and now they are expanding that. So we are there today. So within the next 2-3 years, you are going to see roll-outs here. So it is good that we have the session now because we need to prepare for that.

But in terms of the grocery area we are far away unless some massive new technology, RFID technology, comes down and we get a half-a-cent tag. It is not going to happen.

[...]

Appendix 3B

Excerpt of 2nd Interview Transcript with Company B

Date: Friday, March 14, 2008

Time: 10.00am - 11.00am

Interview type: Telephone interview, recorded as MP3 file via PC in room 253 at IBM Research GmbH, Säumerstrasse 4, 8803 Rüschlikon, Switzerland

Transcript: 7'301 words (of which 3'801 are reprinted in this Appendix)

DR = Daniel Ronzani (interviewer and transcriber)

B = Communications & public affairs, RFID expert at Company B (interviewee). Company B is a retailer.

[...]

DR: How does your company view the proposal [on the RFID Draft Recommendation] that is on the table at the moment?

B: We use RFID for logistics purposes primarily. As you know, logistics certainly extend onto the item level. And that is the vision that leads our development of RFID in Company B. But at the moment, operational-wise we only deploy it in logistics. However, if we look at the recommendation then from our perspective two things are really striking to us:

- One is that the whole regulatory debate on RFID seems to be based more on the perception of the technology among certain people than the reality of the technology in businesses.

- The second aspect is because the use of RFID in retailing is, let's say, rather a transparent one. [...] From our point of view the singling out of the retail section is somewhat unjustified because there are already self codes of conduct in place, the EPCglobal guideline. Most, if not all, retailers doing that are following those guidelines or implementing similar guidelines by themselves if they are not EPCglobal members. And the deployment of RFID in retailing is in very infant stages, still. Specifically if you look at what part of the RFID application actually ends in the hand of consumer. And it is particularly important: because we only have product codes, EPCs, on the tags. The general line basically is: we do not see why we are singled out with threats like "OK you could profile people in the streets with EPC codes on products" at the same time where public transportation tickets are used in London and other places which contain RFID tags and *have* personal information on them. Or passports are introduced all over Europe that have RFID technology in them and carry also personal information, very important personal information. There is a mismatch from our point of view between the regulatory attention on our use case and the dimension of RFID in general.

DR: The first point that you mentioned when you say well, you have the feeling that the regulatory debate is based more on perception rather than on reality. I mean in one of my papers I had reviewed 43 articles, legal articles, and it was my understanding that our legal colleagues had not quite understood how RFID works, if at all. If... if they attempted to make a technological statement in their papers. Now, when you talk about perception v. reality are you talking about the technological part or the economic aspects of RFID?

B: I think it is partially both. But certainly, let's say, in the very early stages of the development of RFID in the late 90s, early 2000, the focus was on the vision and potential that this technology could have in the future. Unfortunately this led to a situation where people who do not like or have problems with the idea

caught this up and took it for real, in the sense of “OK, RFID *could* do this, RFID *can* do this, and anyone who uses RFID will also be able to do this”. We found in deploying the technology starting in 2003 with the first experiment, starting in 2004 with first real trials, that was not at all the case. The basics of the technology were there, the ideas and the concepts were there but the implementation of the technology in real practices, in real processes was quite a different aspect. So our technical view is that only after EPC Gen2 became available, the technology was reliable enough to actually leverage in real processes. On the other hand, the privacy debate specifically focused on the end result of an RFID enabled world, basically. And tries to emphasize what could be done as if this could be done already today, leading to a situation where you have on the one hand pressure groups who singled out RFID as very heavily threatening technology for privacy and data protection. And regulators who came in to look at this issue, came in, let’s say, in 2005, 2006 and had practically two choices to inform themselves: one were those pressure groups and the others were businesses who were still in very early experimental phases of RFID and could say much or could only talk about the end vision. And we to a certain extent also did. And so it somehow flawed impression of what is possible if RFID developed among non-technical people, lawyers and regulators... leading to a situation where now, at least this is our analysis of the current debate, perceived threats are actually what we are talking about. And perceived threats are what regulators actually try to address in their regulation. Not real threats. There was no risk assessment. Nobody actually calculated what it would cost to actually, let’s say, deploy UHF readers in a shopping mall in a shopping district, in a town, and to scan the entire street just to find out who the people are and what kind of products they are carrying and how you would actually do this in terms of finding real profiles and selling that data and so on. We have a fundamental mismatch between the perception of the threat on the part of retailers. I pick up those things and go back to my engineering colleagues and say “well, this is what they claim, this is what throw against us”. And they

say “This can never happen because it cannot work. You cannot do this. It is technically impossible, physics is not right. You cannot do this. There are a host of regulations and rules which you would have to breach in order to build a system like this. It would cost millions of Euros to do it”. So they think “how could anyone sensible actually claim this is a real threat?”. And then the answer suddenly is “well, the people are not necessarily not sensible, they are just not deep enough into the topic knowing the technology good enough to understand which is just a nice, although threatening, idea of what the potential future is, and what the reality of the technology is today and for the foreseeable future”. I mean although it is rapidly developing, and technology progress is there, there is no way of having an item level, full scale item-level situation, at least in retail, for instance, in the next 10 to 15 years. We will have to wait for a long time in order to have this technology adopted all over the place. And most of the threats that are discussed are actually based on the assumption that everything in Europe is already tagged, and you could buy a reader and read anything that goes by and is in someone’s house.

DR: It was always my assumption that this is the case. That the people just do not understand [RFID] and it reaffirms a little bit what I researched in these legal journal articles. However, if I now deliberately play the devil’s advocate and I would say “well, you know, just because it is not possible today does not mean that some time down the road, in a few years it could be possible. And if we invest a lot of time and money and invite the public people to participate in the debate should we not for all the parties, come to an agreement, being here a law at European level that will be broken down to country level that covers maybe not only what is possible today but will also be feasible in the future?”

B: There are two or three aspects that are relevant:

- One is the likelihood of something like this happening in the future. The likelihood has much to do with where the commercial interests of industry users deploy the technology. What is the direction research takes in those

technologies to assess from now into the future 10, 15, 20 years, what would be possible in 20 years. Actually, what is possible or deployed in 20 years in terms of technology is already very likely fully developed in terms of conceptual stages and in early testing phases in research laboratories all around the world, if you look at any technology. If you do not have that, there is a very limited chance that anything would come up in the meantime that would completely change the whole idea of something like this developing. So if you do prescriptive regulation into the future, you would have at least need to have a clear understanding of what the direction of the technology is at the moment, what the next steps are from RFID users and from people that deploy that technology; also what technology vendors have in their R&D labs, what they are pursuing, which strategies and so on. And then say, “well, if we extrapolate from this point we see Company B wants this, Company X wants this, Company Y wants this, other companies, the airlines want this, and so on, and so on; and we extrapolate from there, then we can assess from there what the possible future is. Although you are still looking into a glass bowl trying to predict the future, which is never a good thing for regulators to do, you should at least do this and argue for it and take people by their words in order to make the case for a regulation like this. This, however, is not done at all.

[...]

- Then there is a second argument to prescriptive regulation. Any kind of rule, any kind of indication of preference, of a certain direction technology or research will have effect on what really happens in the world, in the reality of technology development, of people assessing their business cases, and so on. So there are always repercussions involved in decisions like this. If you say, well the argument “even if it is not possible to today, it might be possible in the future and we care of this” any kind or rule you would set against that, any kind of direction you guide people into would certainly have repercussions for the development of the technology

in general. And it is very, very difficult – I would say it is impossible – to assess really what kind of repercussions are that. Because there is a difference between what a regulator in the EC thinks he is doing with a certain sentence in a recommendation like this and a business case person in a company. And the conclusions are not foregone in a recommendation like this. The second aspect of this is it is only a recommendation. So actually member states would have to interpret what is in that recommendation and would have to adopt it. A huge complication for the entire idea of forming a framework in Europe. But, anyone who reads this would draw his own conclusions from that based on, well, on his own idea of what the technology can do and cannot do; based on his own interest in terms of developing his business or application further; and what is said in the recommendation. So it is very, very likely, at least from a theoretical perspective, and I think there are many examples of, let's say, not very successful regulations in the past, where you can actually see this. It is very, very likely that by trying to do prescriptive technology regulation you are actually changing the cores of things that happen in that technology. And by doing this you change your assumption you wanted to present because it will not happen this way. It will happen in a different way. And you have a regulation that does nothing than distort the development of technology. That might be good in some instances. But since the distance between the regulators, on the one hand, and people from the practice and research labs, on the other hand, is that great, it is a lottery game if they find regulation that is achieving a right stimulus. You can set stimuli, no problem. But not with something like this.

DR: One can make the statement that, although you're being singled out in this particular draft here, you do agree that there will need to be some kind of a balance between the stakeholders. I mean if I look at what kind of goals there could be. If you look at the European Union, obviously they will have some kind of an economic goal as well. They want to foster RFID to drive

business in Europe. This will lead to more jobs and lead to wealth and, at the end of the day, socially, hopefully the people will be happy. So, I doubt that the Commission is just going to pull the plug and say, well, RFID does not work. On the other hand, the industry will be looking at the economic part. So, it seems to me here we do have some kind joint goal both of the EU and the industry stakeholders because they are both looking for an economic value out of the implementation of RFID.

B: Yes, but you need to take into account, or at least if you are elaborating on that, a couple of aspects:

One, maybe the history of involvement of the EC in RFID. The involvement started with the industry asking the Commission to become active and to help RFID be deployed in Europe. And the key part in this was spectrum. The question was whether we have an assigned spectrum based on a CEPT recommendation 70-03. That was there. But CEPT recommendations are recommendations that CEPT member countries not necessarily have to adopt. They should. They cannot really adopt something else. But they can keep the old spectrum regulation for this part if they do not want to adopt the recommendation. So end user companies went to the EC and told them about RFID, told them about the technology, told them about the prospects and what they thought, why it was important for Europe and European companies to be able to use that technology, and ask for help in terms of spectrum. Because you cannot deploy UHF RFID technology if you cannot use the UHF spectrum. And that was not the case until rather recently. What happened is, the Commission did that and we are grateful for that. And that was a major breakthrough for UHF technology in Europe that there was a spectrum decision done by the EC that mandated member states to adopt the recommendation.

DR: That is 2006, right?

B: Yes, November 2006. And the adoption was due 2007, I think June or July. And all member states did. So to give you an idea what that meant: in [certain countries] the spectrum [was] already adopted it right away after CEPT issued the

recommendation. In Italy that was not the case. In Italy they even tried to block it after July 2007 because they had some military usage in there and military had interest and tried to block it. So, even if we could deploy RFID technology in [certain countries we] could not do the same in Italy because we are not allowed to use the spectrum in the same way.

DR: So regulation becomes an inhibitor here.

B: Yes. But European regulation was certainly key to unlock the potential of that technology. I mean if we would not have the certainty to have the technology in the entire internal market the business case for any hardware vendor looks quite different. Having that harmonized throughout the entire internal market was of key importance. So yes, very good, the same interests.

Then, second aspect. One thing is the economic goal of the EU, i2010 and ICT deployment in industries, and so on, and so on. And that is certainly valid goal and we are always aligned with the Commission on that. For us in retailing RFID is one of the key ICT technologies. We think we can deploy in order to really make our processes more efficient. We say that on a basis of already very efficient processes that are based on electronic communication systems, on modern IT infrastructure, etc. and we still think that RFID can bring us a new dimension of efficiency in our process. And they agree with us on that. But the privacy aspect has a political value for people in the EC. And the political value is something completely different. The long term goal of ICT development and competitiveness in Europe is basically a given. No one would actually dispute that.

[...] Privacy is a very interesting part because many, many people have very diffused concerns about privacy. Many of the privacy arguments are intuitively understandable to a whole lot of people. I mean I would not rule myself out there. And I think nobody really can. And so you can really play ball with those fears. [...] That political dimension certainly goes against what we try to do because what we try to do is to talk about the benefits of the technology and to raise awareness in the sense what the technology could actually offer to consumers and how

it is deployed so that people can at least have the chance to rationalize their opinions about RFID and do not have to go with the undifferentiated feelings about the technology. So, yes, the European level, the EU helps, has been helpful and still helps to certain extent. [However,] we think that it over-emphasizes privacy risk and does not emphasize the potential and economic value of the technology like this enough; also not competitiveness in international terms. I mean we should be aware that even if we would stop RFID in Europe the US and Asia would not do that necessarily as well. So we would have the products here, maybe a couple of years delayed, but we would have the products and technology in Europe as well after a couple of years. Then completely unregulated because we possibly could not block those. So this is the status right now. Having said that, certainly if the recommendation is adopted in a way that we can live with, there is a potential that this recommendation could be used to once and for all or at least for the time being stop the privacy debate and re-shift the focus of the debate on applications and how we can stimulate industries in Europe to think of their particular use cases for the technology and how they could use the technology to make their processes more efficient.

DR: Do you have the feeling that technology/business and law are following diametrical goals and, in this instance here I understand law as being the regulator, would you answer this question with a yes: yes they are following diametrical goals, or no: they are following the same goals?

B: I would say a qualified “yes”. The industry is one player and regulators are the other players. In industry there is a quite high amount of alignment among, at least, EPCglobal members and most other EPCglobal technology users. On the regulators’ side that is not necessarily the case. So privacy people have a different opinion of RFID than business and economic development people. So it is not black and white in a sense. [...]

DR: So they are playing a double-sided sword here. They are playing the economy v. social part – being in this case here – the people and the privacy issues.

- B: Yes. There are a couple of metaphors you could come up with. But one is certainly the big guys against the small guys, right? [The companies] can do whatever they want to. However, you and I as single consumers we cannot do anything. We are just affected by all those changes. We cannot decide. So we are the little guys that need to be protected while the big companies are the bad guys that can do whatever they want, and have to be restrained in order to enable a protection for the little guys. So, that is how consumer groups play this. Consumer groups say “well, there are concerns, and we need to take those concerns seriously”. I mean, we certainly fully agree with that. People need to trust us [...]. We depend on the trust of our customers.
- DR: But it is interesting to hear that you already take up the legal and regulatory issue in your business case whereas other companies might not even take up the issue before implementing it. They might not even care about it.
- B: Yes.
- DR: There is a big difference here.
- B: The difference here originates from the type of business you are in.
- DR: You mean the industry?
- B: [Yes ...]
- DR: If one would compare the data privacy risk of a loyalty card with the risk of an RFID tag – at least, let’s say, until the time of purchase: the issues would seem to be the same to me. If I want to profile, I can profile. So someone that has a loyalty card should probably not be too frightened about a company using RFID tags at item level. Or is my perception wrong?
- B: No, it is not. Loyalty cards are already based on an opt-in principle. What we are fighting in RFID is the opt-in principle, i.e., an opt-in principle for any kind of RFID application. Such an opt-in requirement would be imposed in addition, or on top, of the existing one. The underlying argument here is it does not change anything in terms of data protection, customer data and so on. Not with loyalty cards, neither with electronic payment

cards or anything. The same regulation, the same rules apply to our IT systems or our backend systems and so on, that apply in the future, that apply now. And RFID does not change the risk of data being processed illegally because already today we cannot do this. We have in Europe the data protection directive and the relevant implementations of that in the member states. And those very clearly describe if you are collecting personal data you have to have the informed consent of the guy whose personal data you are collecting, i.e., opt-in. People have to sign a document if they apply for a loyalty card. And in this document you find exactly specified what [can be done] with the data collected via the loyalty card. And [one is] inhibited by law to do anything else with the data.

DR: I agree. It is a stiff regulation.

B: In this sense loyalty card is a very critical part in the whole discussion because loyalty cards have to some extent a bad image. And the bad image results from people having no idea what data protection laws actually are.

[...]

Appendix 3C

Excerpt of 3rd Interview Transcript with Company C

Date: Wednesday, June 25, 2008

Time: 9.45am – 10.35am

Interview type: Telephone interview, recorded as MP3 file via PC in room 253 at IBM Research GmbH, Säumerstrasse 4, 8803 Rüschlikon, Switzerland

Transcript: 5'502 words (of which 3'396 are reprinted in this Appendix)

DR = Daniel (interviewer and transcriber)

C = Senior researcher and architect at company C (interviewee).
Company C provides SW/supply chain management for RFID.

[...]

DR: How do you position Company C within the RFID space, and the services that you either receive from any subcontractors you have or services that you use and pass on to your customers.

C: Company C positions itself as the owner of the business processes. Currently, mainly in supply chain management. There are some other applications as well like asset management or mobile asset management. To put it very shortly, it's basically about what do we do with the data that we can get from RFID or the information we can get from RFID readings. The prime example is supply chain management that we can track the delivery of goods, the transportation, etc. Or just get better visibility within your supply chain. That is maybe the most common term. We do have some SW products in that space, mainly the auto ID infrastructure which is sometimes termed as some kind of middleware. But I would more term it as

intelligent middleware in the sense of that it makes the link between simple RFID reads to the business processes.

DR: I look at a five stage implementation: a business case, proof of concept, a pilot, an initial implementation and a full roll-out. Where at the moment do you see Company C with its customers?

C: Company C is trying to cover all five spaces in its individual projects. Especially we are looking at the business case, etc. I think that is where the importance for Company C is. We partner then with companies for the device integration aspects. If you look at it overall how far the technology has developed, I think we do have some business cases, we have certainly some pilots and we also have some live customers.

[...]

DR: If we look again at these five stages where do you know or anticipate should the discussion about legal regulation take place? At what stage, if at all, do you take up any legal aspects that might arise with the customer?

C: I would say things like privacy are certainly brought up. At least to make the customer aware of it if he is not yet aware of it.

C: Well privacy is not really an issue because it is supply chain management in the logistics part and not at the end consumer. Or also the mobile asset management, privacy is not really an issue.

DR: Is this not really an issue because you would say it is a close-loop? And the items never go out as far as to the end customer?

C: Well, yes, partly it is close-loop, partly not. But the point is we're not attaching RFID tags to any individual items that are then owned by consumers. Or any workers or anything like that. But the RFID tags are attached to pallets and cases. This might be close-loop which in the case of cases is probably an open-loop but no tracking of people. I just have the tracking of the goods. From that perspective I do not think there are really privacy issues. I mean, we have in the past run into these with

Company B, etc. I would say the industry in general, they were underestimating the privacy issue.

[...]

DR: And now somehow it exploded and everyone is talking about privacy issues. Did you have an opportunity to look at the consultation of the European Commission that was issued in February?

C: Yes, I did. There are a few things to keep in mind with the privacy aspect. Or also with other aspects. But when you say frequency, do you mean which frequency you can use, or at what power? Or do you mean issues like electronic smog that could potentially be a health issue as well as radio stuff going on?

DR: It is the first. What bandwidth can I use it? I mean, if I look at the three [frequency] regions we have, I believe it is getting a bit better. But there were some issues in Italy where you could not use a certain bandwidth because it was set off for the military. And then if you wanted to use it you needed to get special permissions, etc. So it seems to be at least from such a legal perspective a hindrance, at least from my viewpoint. There is no harmonization at the moment but I think we are getting there. But it is not yet set as it should be.

C: It certainly has improved a lot over the last years. Also the regulations in the US and Europe have come closer. They are not the same but they have come closer. Regarding privacy, the privacy aspects but also like e-smog, etc. I think you have to take the concerns seriously. But on the other hand also realistically. I mean, the industry was at one point in time appeasing, not taking the concerns seriously, saying it was not really a problem, etc. This sometimes is true. But it gave the wrong impression. And while some consumer organizations were, on the other hand just hyping things which were technologically not possible by far. So we need certainly a discussion on that. We need education on that, starting actually very early. Then, what we have to be careful about with regulations, is that we do not stifle competition. Regulations

should be there to allow for companies to compete and bring solution on there but not hinder innovation. So I was once at a seminar or a workshop.

DR: So from your perspective there is too much regulation or the wrong regulation?

C: The frequency is one issue. There we obviously need harmonization. Regarding the privacy aspects I do think there are, I mean, quite a lot of European law, or at least guidelines, regarding data collection, etc. And we should try to apply these and not make some special RFID laws. Because RFID is just a technology. The point is what you do with the data that you collect. And there I think we have some regulations in place that are quite valid and that should be kept. To what extent, and that is the other interesting question, they will be applicable in the future, I mean, especially the issue that you can only collect data for a special purpose and only for that purpose, or else you have to delete the data. Well, that might be quite difficult to keep in the future.

DR: Because?

C: The whole promises that this kind of thing has is exactly that you are tracking data to know what is happening. And it is sometimes not clear from the beginning what you collect the data for.

DR: You mentioned at the beginning that Company C is in the space of middleware linking the RFID read to the processes. So I understand this to fall exactly within what we just discussed now. You are making the link to the database and lots of information or the RFID you mention here will be stored in some kind of a database. And you as Company C have some kind of ability to give access to it or not. The information is not stored on an RFID tag. It is just a code on the tag and all the information that I can gather together is at the end in a database. Now, from my perspective, where is the danger here? People do not have access to these databases, in general. If they do get access to it without being legally permitted, obviously they are violating the law. Are we not

moving into a direction here, as you mention, where we are over-regulating? We already have laws that say you are not allowed to do it. You are not allowed to just enter into a database, you are not allowed to use a SW without permission and get access to data.

C: That is my point, yes. I am not a lawyer. I cannot say if the laws we have are sufficient, or not. But I think we have to first look really at that. And maybe if you say they are not sufficient, they are missing some things, then yes, then change. But I do not see really the need to say we have this RFID technology and need to make new laws of RFID because I think the privacy issues are already covered with existing laws. And to make one thing regarding what you just said: It is not Company C that has the control of or access to that data and the databases.

DR: So the SW of the customers is from a technical viewpoint sufficient, has technical security to make sure that only the right people have access to it.

C: Yes.

DR: So, if I go back to the EC consultation, it is a guideline. At least this is what they mention. Well, with the guideline and the countries, or the Member States of the EU can adopt the guideline or they cannot adopt the guideline. From your perspective does this make any sense? We have 27 countries in Europe that would adopt this. If only one country does not adapt the guideline, from your perspective, does this make any sense?

C: No.

DR: You have the guidelines in A but you don't have them in B. Don't you think it would probably be better to have instead of a guideline then at least a law that everyone *has* to implement?

C: The question is to a certain extent: do we need new laws? So yes, there if we have laws that are different across the member states then, I really do have a problem.

C: If it is just guidelines, probably not. But yes, it would certainly be desirable that we do not have different guidelines and different

rules in different states. Another thing though is also to what extent can we have industry guidelines, or codes of conduct, and things like that to cover the fears, etc. Sometimes law does not fit very well with both industry requirements as well as the actual technology that it is about. So the question is: to what extent can you just have codes of conduct like the OECD codes of conduct. But the OECD has some rules regarding the privacy aspect. And EPCglobal as well.

DR: It is actually quite interesting. We have these two in place, OECD and EPCglobal guidelines. And nonetheless the EC consultation suggested that we put such guidelines in place. We already have them. Do you think they are sufficient?

C: Personally, yes, I do think that they are sufficient. What maybe is missing in the sense, is an independent body or something that can actually check that these guidelines are followed. That people and companies actually live after these guidelines. And that it is not just a piece of paper.

[...]

DR: Radio frequency, you mentioned two topics, the bandwidth and also health aspects. I had never thought of the health aspects because what I have read or heard so far is that frequencies we are operating with are not harmful.

C: No.

DR: Obviously there are some opinions stating otherwise.

C: Personally, but you know that is more of informed opinion and not any physics or whatever, I don't think that it is really harmful. I think what we have with mobile phones is a lot worse. Sometimes the same frequencies and definitely stronger power. So if mobile phones are not a problem then I think that RFID is not a problem either. What I meant, when I mentioned that, was more that a lot of the things we have today are not really relevant to privacy. And there really has been hype by some organizations that pushed this privacy problem. I do not say there is no problem at all. But it was pushed in a way which was sometimes not really realistic. The problem in retail if often not

that you have RFID but that you have a [loyalty card]. And that gives you all information about the consumer already. Nobody cares about that. If there is an RFID on that is, in my opinion, not that important.

But the health issue just regarding mobile phones [...] I mean also with mobile phones I think the discussion is open to what extent they are really harmful or not. The majority believes that it is probably not that harmful. With the mobile phones it is clear; mobile phones have a very practical usage for everybody. So people might be more willing to accept some risks. While with RFID for the average consumer [...] well [...] the benefit is not always clearly visible. It is more for the companies that they can have more sufficient supply chains or whatever. But it is not always that visible. If the majority of consumers fear it *could* be dangerous, well, they will try to avoid it. So this is a topic that could come up. And I would hope that the industry would be more proactive about this than waiting until it explodes like it did with privacy.

DR: What do you mean with being more practical? Actively informing?

C: Yes. Exactly. The risk includes privacy, includes the health issues that I just mentioned as well as environmental issues which might even be the bigger thing than the health issues. If you suddenly have electronics in all the products, what do we do with all the electronic waste? [...]

DR: So you say it becomes a political discussion not based on science whether it is harmful or not. It is just if the people perceive it to be dangerous or it could be dangerous for them, and they make an *un*informed decision,

C: Exactly.

DR: And it just explodes.

C: Yes. One can summarise it like that.

DR: But this will be the case if we look, for instance, at a retail store that is in daily contact at retail level with end customers. You mentioned that Company C was not at that level, that you were

at pallet or case level. But you do anticipate that Company C will, in the future, push forward the retail business as well?

C: Technically speaking we can do item level already now. We also do that at item level. It is not a technical issue. It is more that customers currently don't accept some high tech issue. I mean in the consumer goods area there is just no market need yet for item-level tagging, mainly for two reasons:

- One is it is still too expensive. I mean the famous cup of yoghurt, even a 1 cent tag, which we do not have yet, is probably too expensive.
- And secondly what retailers really would like is, it was actually shown in an IBM commercial, that the customer can basically put everything into the cart and then walk out of the store. And then what you took out of the store, the prices are automatically scanned and deducted from your credit card without needing to queue at the check out. Retail goods have lots of water, lots of metal, etc. There are still severe technical issues to realize in order for the technology to be actually reliable enough. So that is why: reliability of technology at that level; and the cost is still a hindrance at item-level tagging.

DR: What is the price you anticipate we need to have for a passive tag that we can stick and throw away? 1 cent?

C: It depends on the type of goods. If we talk about the cup of yoghurt definitely below 1 cent. And we will only get there once we'll have polymer electronics. So printable tags, basically. I think we can get there in the future but that is still several years away.

DR: From your researcher viewpoint, how many years away?

C: We have now, let's say, the first printed circuits also in the 13.56MHz space. But until that is really fully commercial that will certainly take five years.

DR: Five years for research and then another few years until it spreads out into the economy.

C: I wouldn't expect to see that within five years already in the stores. I do not think so.

[...]

DR: If we go back then to supply chain management that you mentioned for Company C. Have you somehow come across any discussions either in your research or discussion with customers that you might have attended where databases have been any issue whatsoever?

C: I have not been aware personally of such discussions.

DR: OK.

C: I would assume that what is mostly used in supply chain stuff and RFID provided is that it is a more efficient way of collecting the data. But the data that you collect is not that much different. OK, you collect more, so you collect at a finer granularity. That might be different. But from a principle perspective it is not much different. I would assume that such questions would have been addressed in earlier products already.

DR: Do you have the feeling that we are, we – I mean society – are doing a good job in trying to bring the regulation and technology together, or do you have the feeling that these two topics, law (or regulation) and technology with regards to RFID are moving further apart from one another? Or maybe I can reformulate: do you have the feeling that if we continue the way we are continuing at the moment with research, with implementation in the private sectors, or even implementations at government level, do you have the feeling that the way we are proceeding at the moment with regard to RFID as technology, that this is the proper way? Or do you have the feeling “oh, maybe we should, you know, stop, rethink and take a turn left or right, at the moment.”

C: No, generally I think we are moving in the right direction. Also if I think about, if I look back a few years, how the discussions have evolved, I would say there is a much stronger consensus now: what needs regulation, what does not, etc. So, in general, I think we move in the right direction. There might be things

here and there which I do not agree with, of course, where there are still disputes. But in general I think it is quite OK.

DR: And if you look at Europe, do you think we are positioning ourselves in the right direction as compared to other regions?

C: I would say yes. Generally speaking. Looking at what is happening at the Commission, etc. is that the Commission has realized that we are talking about more than just RFID here. We are talking about what is called the Internet of Things which is not just RFID. That is just an enabling technology, but includes sensing, sensor networks, etc. etc. And this should kind of form a future Internet where Europe is trying to position itself now with things like Future Internet Assembly and lots of meetings going on, etc. etc. So that is good. Also the ONS dispute, so to speak. Up until now ONS was run by Verisign, a US company as the only global or top level ONS, so to speak. There are discussions on the way that we will have like the DNS also several root servers; that the ONS as well will have several root servers, one of them being actually currently set up in France. If that is happening then that looks better. I see it as dangerous if we would just have a single root server for an ONS in one single country, regardless if that is the US, Japan, China, France, Germany, or whatever. We should not have just a single root server with a government that if they decided to shut it down or limit access.

DR: So we are not dependent anymore of another region.

C: Well, currently, we are. With the current ONS we are. Although ONS is not that important yet. But assuming it will then it is really critical that this will be distributed and that we have root servers basically in several regions.

DR: OK. And you say the one that is anticipated will be in France.

C: That is under discussion, yes.

[...]

Appendix 4

Online Survey for Survey Article

I. Contact Information

1. [left blank]
2. [left blank]

II. Company / organisation related questions

3. Does your company / organisation engage legal experts for legal questions on radio frequency identification (RFID)? (up to two answers possible)

- Yes, we have *inhouse* lawyers (go to question 4)
- Yes, we have *external* legal counsel (go to question 4)
- NO, we do not engage legal expertise (go to question 5)

4. If question 3 is answered with "yes": In which phase of RFID implementation does your company / organisation deal with legal issues? (multiple answers possible)

- RFID production (hard- or software)
- Business case phase (i.e., evaluation of RFID: will RFID help your company / organisation?)
- Proof of concept phase (i.e., infrastructure testing: what RFID SW/HW could you use in your company / organisation?)
- Pilot (i.e., validation in your environment: does RFID work in your company / organisation?)
- Initial implementation (i.e., single roll-out: using RFID at 1 location of your company / organisation)
- Full implementation (i.e., full roll-out: using RFID at many/all locations of your company / organisation)

5. If question 3 answered with "no": In which phase of RFID implementation do you believe should companies / organisations in general deal with legal issues? (multiple answers possible)

- RFID production (hard- or software)
- Business case phase (i.e., evaluation of RFID: will RFID help your company / organisation?)
- Proof of concept phase (i.e., infrastructure testing: what RFID SW/HW could you use in your company / organisation?)
- Pilot (i.e., validation in your environment: does RFID work in your company / organisation?)
- Initial implementation (i.e., single roll-out: using RFID at 1 location of your company / organisation)
- Full implementation (i.e., full roll-out: using RFID at many/all locations of your company / organisation)

III. Regulation related questions

6. In the past, have you experienced problems in your work with RFID based on

- database regulation?
- radio frequency regulation?
- privacy regulation?

[Likert scale: very frequently; frequently; occasionally; rarely; not at all; unaware of regulation]

7. In your opinion, how adequate or inadequate are

- *data privacy* regulations to protect privacy concerns?
- *database* regulations to protect privacy concerns?

[Likert scale: very adequate; adequate; neutral; inadequate; very inadequate; unaware of regulation]

8. In your opinion, how adequate or inadequate is the following legal people's expertise on RFID?

- Legislators
- Lawyers
- Judges

[Likert scale: very adequate; adequate; neutral; inadequate; very inadequate]

IV. Economy related questions

9. How positive or negative do you rate the use of RFID

- for the *economic* success of your company / organisation?
- for the *sustainability* of your company / organisation?
- for the *reputation* of your company / organisation?

[Likert scale: very positive; positive; neutral; negative; very negative]

10. In your opinion, what would make the RFID market take off faster?

- Avoid bad RFID press as much as possible
- Worldwide RFID guidelines by organisations (e.g., OECD, EPCglobal)
- Education of the general public / consumers on RFID
- Worldwide RFID standards (e.g., EPCglobal, ISO)
- Lower RFID tag price
- Better RFID architecture and technology
- Laws on RFID

[Ranking: 1 = very relevant; 7 = not relevant]

11. [left blank]

V. Consumer related questions

12. In your opinion, is the knowledge of the general public about RFID

- good or bad?

[Likert scale: very good; good; neutral; bad; very bad]

13. In your opinion, how good or bad is the general public informed about RFID

- by the RFID industry (e.g., retail)?
- by the RFID regulatory?
- by RFID consumer organisations?

[Likert scale: very good; good; neutral; bad; very bad]

14. In your opinion, what is the best way to inform consumers about changes and risks of RFID?

[Selection: multiple answer possible]

- Placing signs (e.g., pictograms) where RFID is used.
- Education at schools and universities.
- Individual RFID seminars.
- No specific information: "learning by doing".
- Public RFID information gatherings.
- Advertising (newspapers, Internet, TV, radio, etc.).
- Other (please specify)

VI. Technology related questions

15. [left blank]

16. In your understanding, do "active RFID tags" include the feature of automatically submitting a radio signal (so-called "beeping" or "beaconing") to the environment?

- Yes, active RFID tags can beep/beacon.
- No, active RFID tags cannot beep/beacon independently.

Appendix 5

Results of Online Survey (Raw Data)

I. Contact Information

1. [left blank]
2. [left blank]

II. Company / organisation related questions

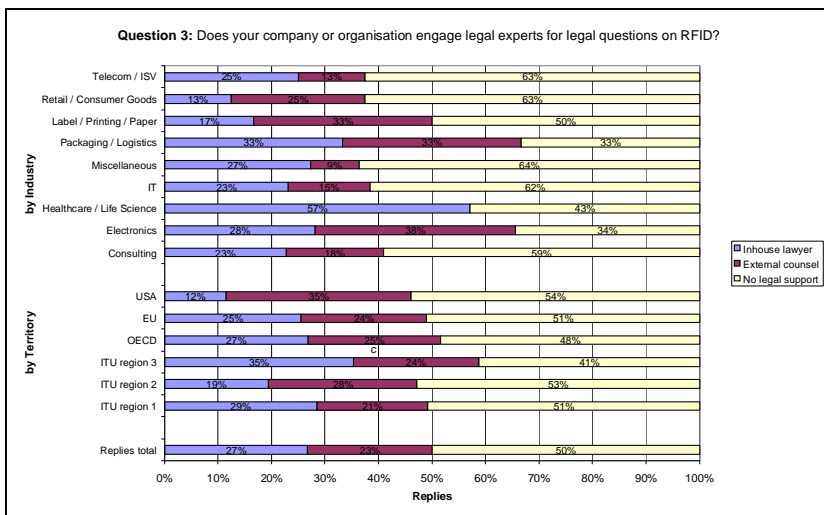

Chart 1: Survey question 3.

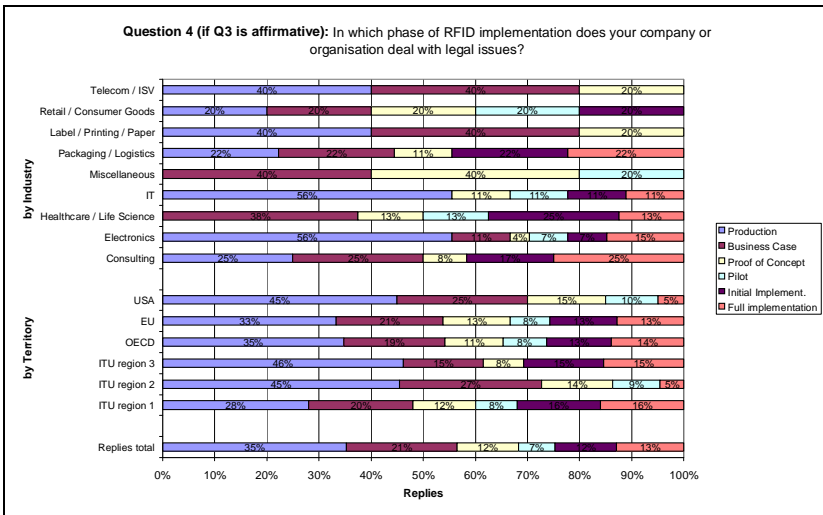

Chart 2: Survey question 4.

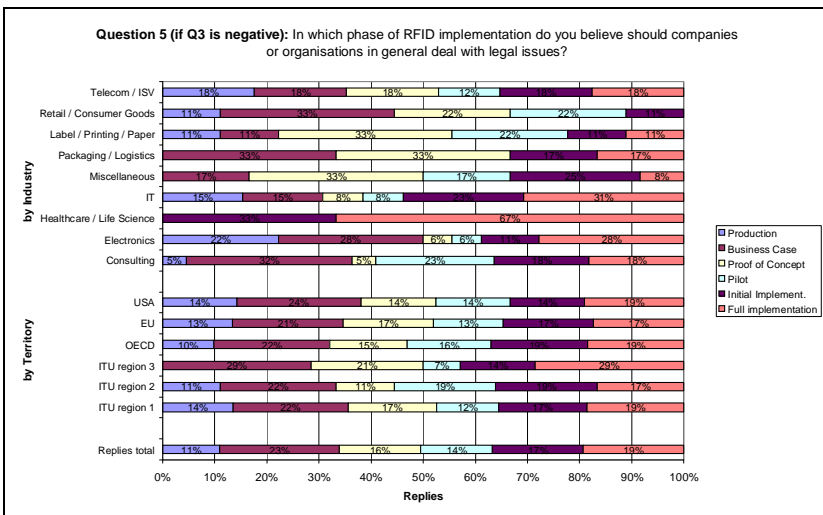

Chart 3: Survey question 5.

III. Regulation related questions

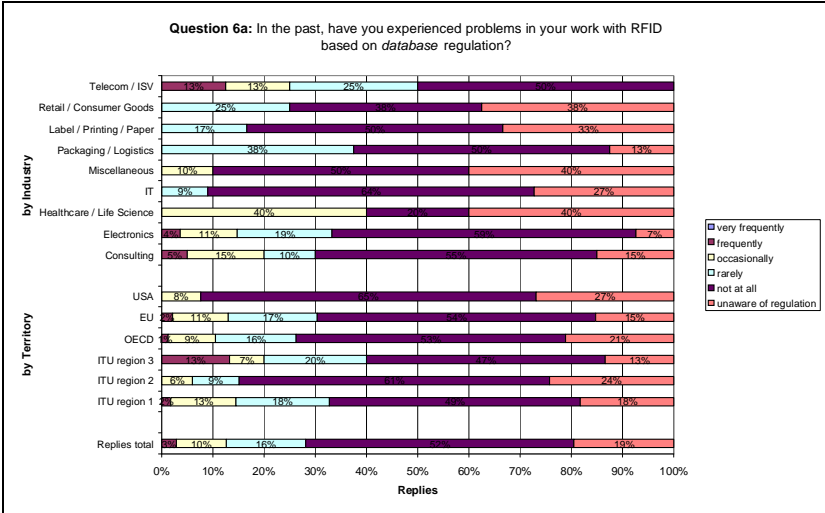

Chart 4: Survey question 6a.

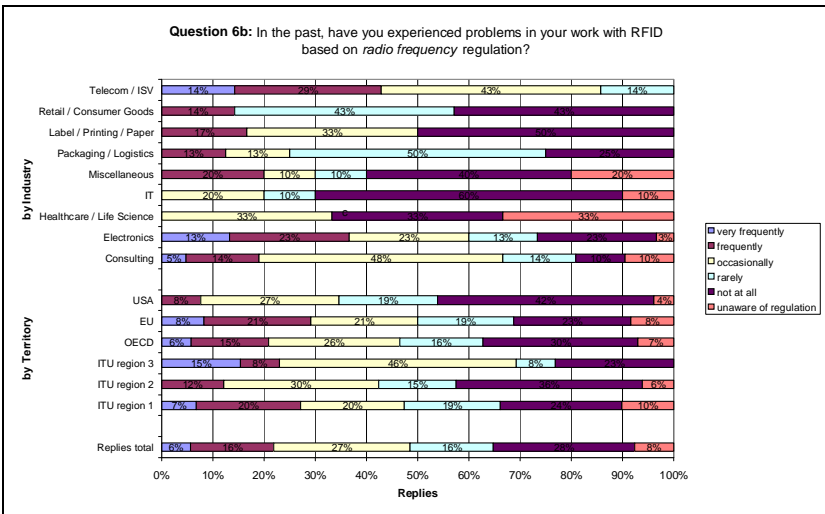

Chart 5: Survey question 6b.

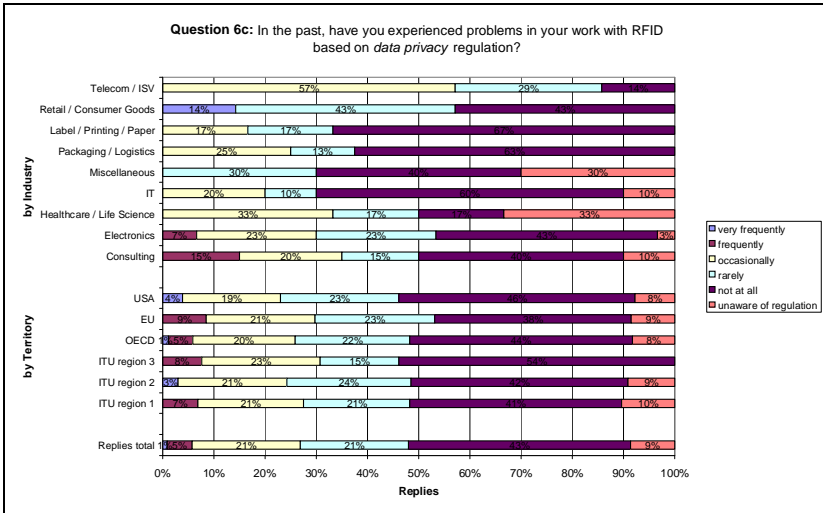

Chart 6: Survey question 6c.

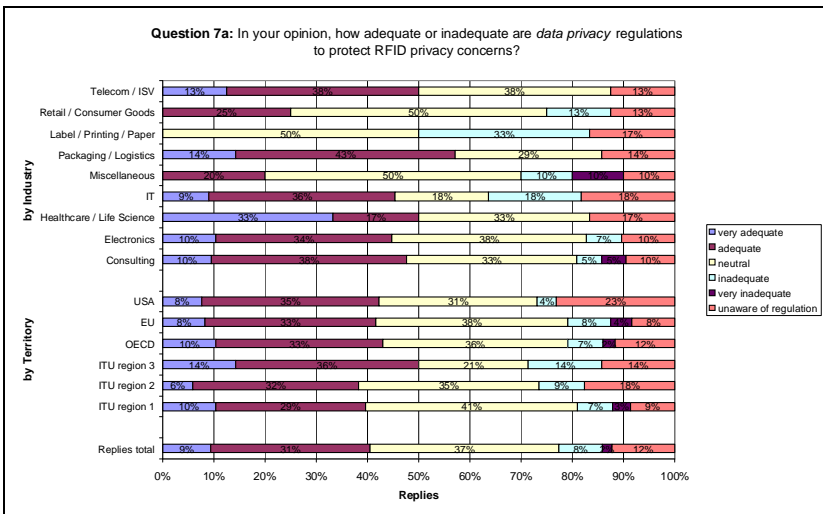

Chart 7: Survey question 7a.

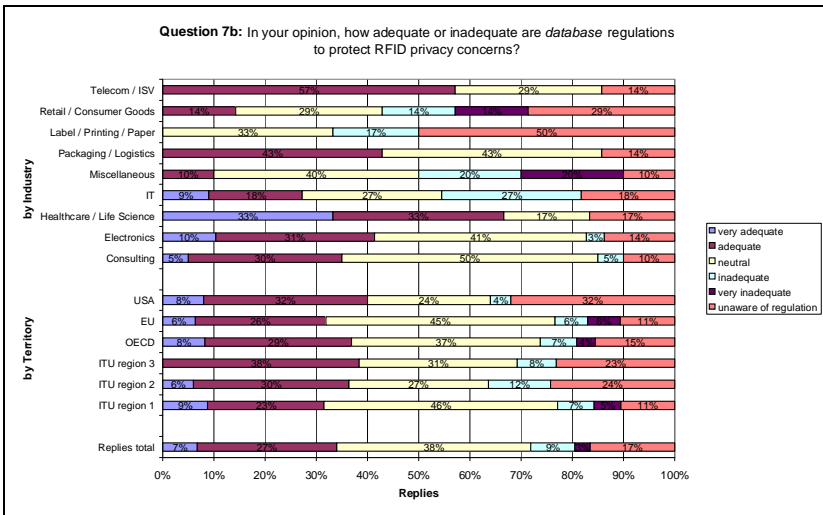

Chart 8: Survey question 7b.

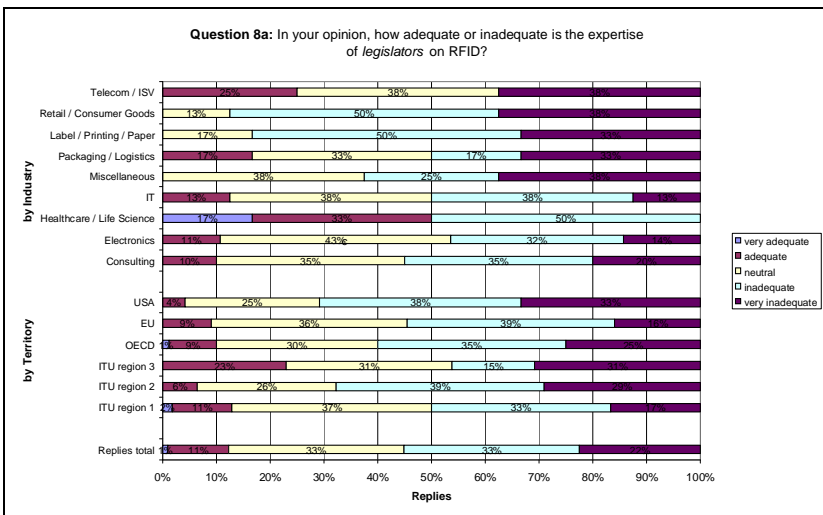

Chart 9: Survey question 8a.

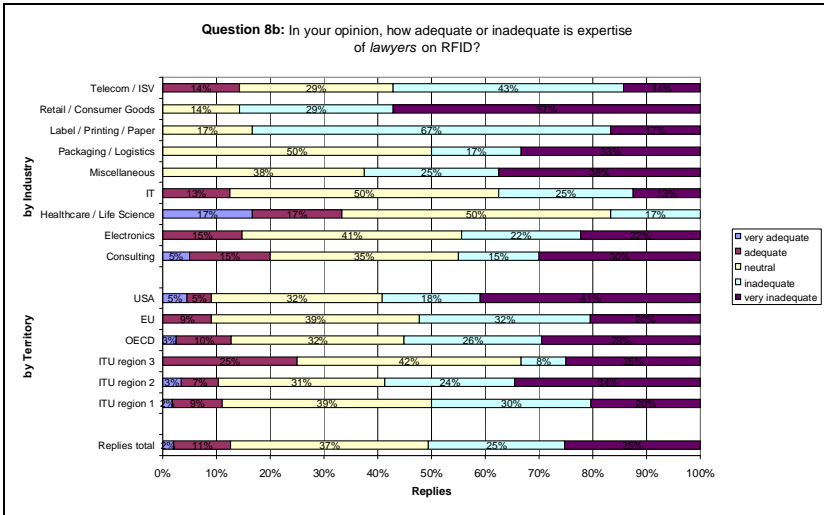

Chart 10: Survey question 8b.

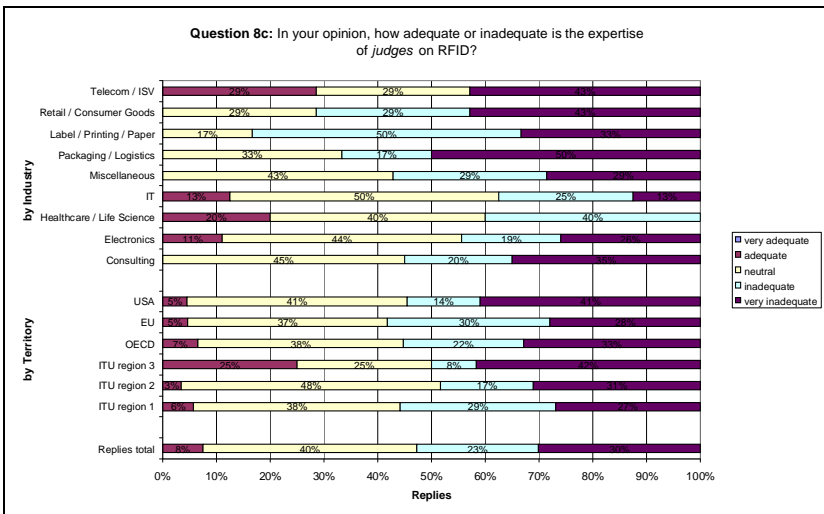

Chart 11: Survey question 8c.

IV. Economy related questions

10. [left blank]

11. [left blank]

V. Consumer related questions

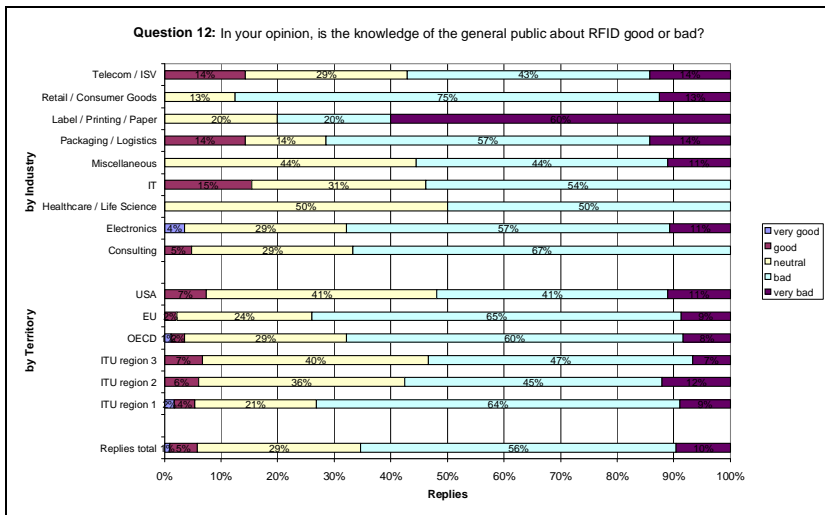

Chart 12: Survey question 12.

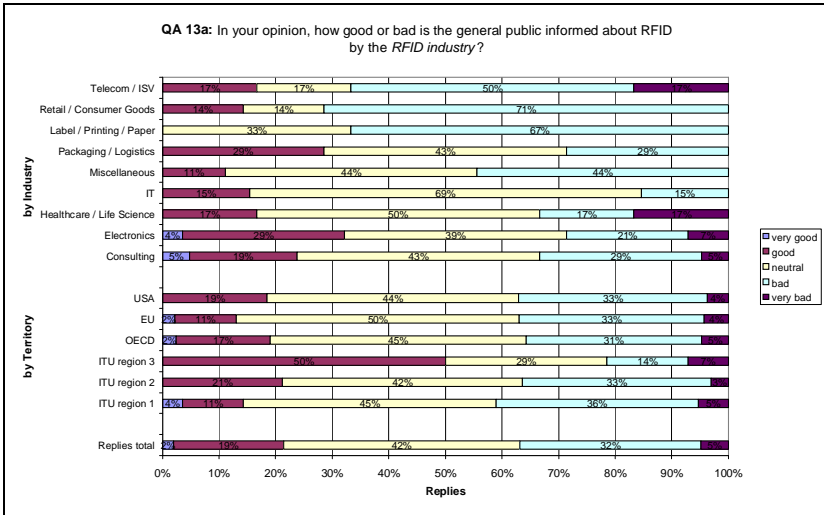

Chart 13: Survey question 13a.

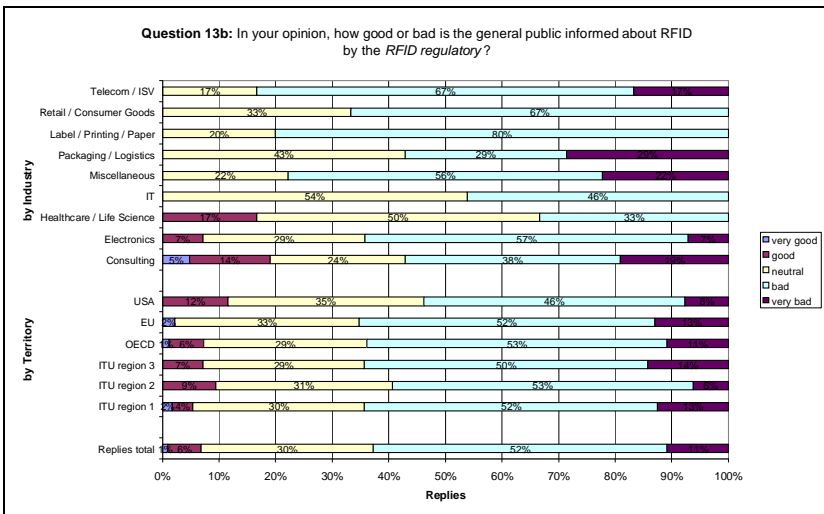

Chart 14: Survey question 13b.

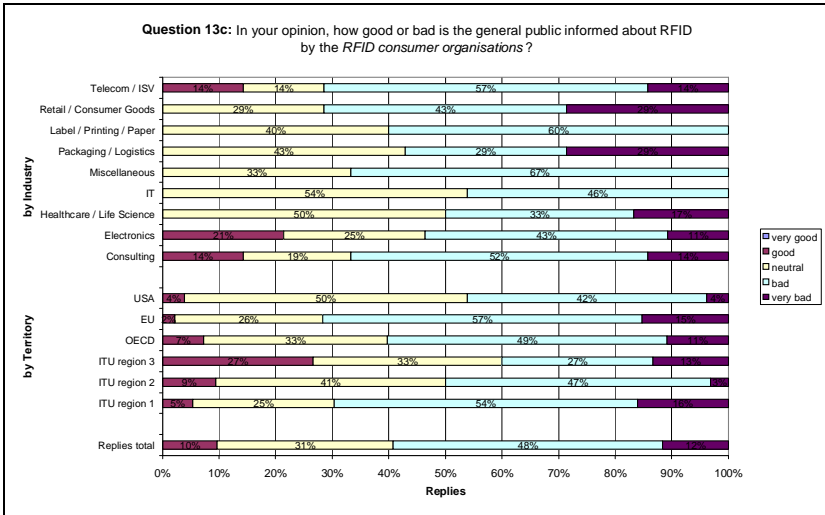

Chart 15: Survey question 13c.

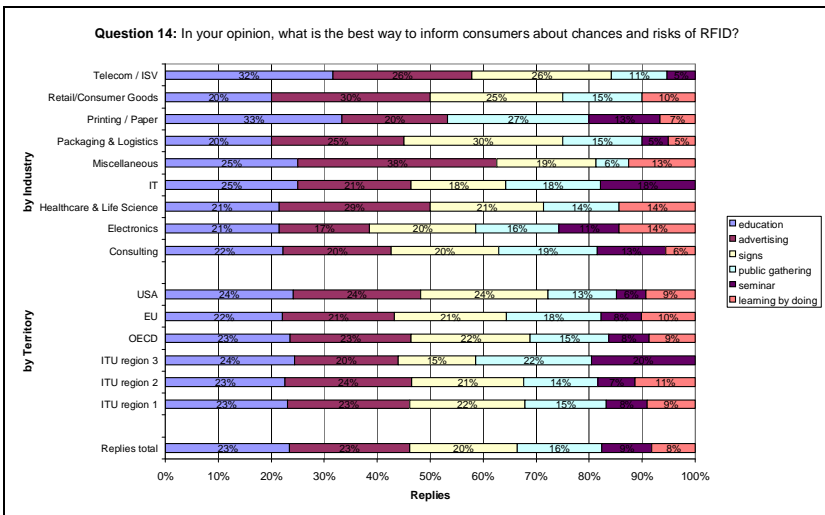

Chart 16: Survey question 14.

VI. Technology related questions

15. [left blank]

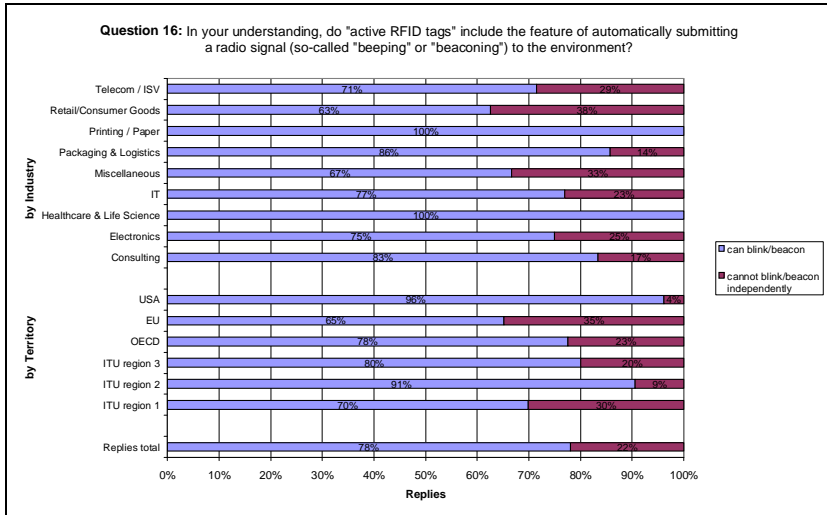

Chart 17: Survey question 16.

Appendix 6
Characteristics Used in Journal Articles on
Adoption and Diffusion of IT, EDI and RFID as
Technological Innovation
(in Alphabetical Order of Characteristics)

GLOSSARY

APA	American Psychological Association
ATM	Automated Teller Machine
CBS	Copenhagen Business School
CEPT	Conference of European Postal and Telecommunications Administrations
col.	column
C-TAM-TPB	Combination of TAM and TPB
DB	Database
DBA	Doctor of Business Administration
DBMS	Database Management System
e.g.	exempli gratia
EC	European Commission
ECJ	European Court of Justice
EDI	Electronic Data Interchange
EDPS	European Data Protection Supervisor
EPC	Electronic Product Code
EPCIS	Electronic Product Code Information System
ERP	Electronic Resource Planning
et seq.	et sequitur
EU	European Union
FIP	Fair Information Practices
FMS	Flexible Manufacturing System
GHz	Gigahertz
i.e.	id est
ICT	Information and Communication Technologies
IDT	Innovation Diffusion Theory
Inc.	Incorporated
IS	Information System(s)
ISO	International Standardisation Organisation

IT	Information Technology
ITU	International Telecommunication Union
kHz	Kilohertz
Ltd.	Limited
MHz	Megahertz
MPCU	Model of PC Utilisation
MRP	Material Requirements Planning
O	Observation
PCI	Perceived Characteristics of Innovation
PET	Privacy Enhancing Technology
PhD	Doctor of Philosophy
POC	Proof of Concept
p. (pp.)	page(s)
RFID	Radio Frequency Identification
ROI	Return on Investment
RTLS	Real Time Location Service
SCT	Social Cognitive Theory
sec.	section
TAM	Technology Acceptance Model
TAM 2	Extension of Technology Acceptance Model
TPB	Theory of Planned Behaviour
TRA	Theory of Reasoned Action
UHF	Ultra High Frequency
URL	Uniform Resource Locator
USA, US	United States (of America)
UTAUT	Unified Theory of Acceptance and Use of Technology
v.	versus
viz.	videlicet

PART TWO

**PUBLISHED / SUBMITTED RESEARCH
ARTICLES**

1. DATABASE ARTICLE

The Absence of Legal Database Protection in the EPCglobal Network

Daniel Ronzani

Published in: International Journal
for Intellectual Property Management
Vol. 1, Issue 4, pages 341 – 350.

Reprint and publication of author generated version of the article with
courtesy of Inderscience Enterprises Ltd. (14 October 2009).
Copyright with Inderscience Enterprises Ltd.

Changes to format and references.

The Absence of Legal Database Protection in the EPCglobal Network

Daniel Ronzani

Copenhagen Business School, Department of Informatics,

Howitzvej 60, DK - 2000 Frederiksberg

E-mail: dr.inf@cbs.dk

Abstract

The EPCglobal Network offers an efficient system for the deployment and administration of RFID in the supply chain management. Its partly decentralised structure triggers questions about data compiled in the EPC Information System and in RFID databases. This paper gives an overview of the base technology of an RFID system and the EPCglobal Network. It aims at directly applying the rulings of the landmark cases on copyright and database protection Feist (USA), CCH (Canada), and Horseracing / Fixtures (European Union) for RFID data compiled in the EPCglobal Network. It concludes that there is no strategic location advantage for RFID databases in the EPCglobal Network in either of the countries or regions.

Keywords

RFID, Database, EPCglobal Network, Feist, CCH, Horseracing.

1 Introduction

Radio Frequency Identification (RFID) is a fast emerging technology. Its use will potentially affect vendors, users, technology adopters and integrators (Lahiri, 2006). Legal issues evolving around RFID are nowadays mostly driven by data privacy law. This paper takes another approach by looking at the legal challenges of information gathered and stored in the EPC information system (EPCIS) and RFID databases.

EPCglobal Inc., an initiative of the Uniform Code Council, Inc. and the EAN International (GS1), is leading the development of industry-driven standards for the deployment of electronic product codes (EPC) in RFIDs. Because first, the access linked to the EPC stored in an RFID is leveraged through the Internet by using the EPCglobal Network, and second the protection of databases is legally treated differently in the USA, in Canada and in the European Union, the decisions of database locations for businesses operating at international level can be of strategic importance. The purpose of this article is to analyse the EPCglobal Network Architecture Framework in light of the landmark decisions on copyright and database protection in the USA (Feist), Canada (CCH) and European Union (Horsereading/Fixtures).

I shall approach the analysis by first introducing the base technology of RFID systems, database systems and the EPCglobal Network. After briefly recalling the landmark court decisions I will directly apply the rulings of the three court decisions. I conclude with a recommendation for enterprises considering the deployment of EPC coded RFID tags in the supply chain.

2 RFID Systems, Database Systems and EPC-global Network

In order to successfully conduct the legal analysis of RFID at database level, the technical parameters must first be set. In this section I will outline the essentials of an RFID system and of the EPCglobal Network. The basics of a database and a database management system (DBMS) are explained.

Fig. 1 shows the following example: Company A produces a product and stores the object information (see below section 3) in the RFID database and/or EPCIS (full arrow). Company A allocates a new EPC with the physical object through the EPCIS and maintains the object naming service (dashed arrows). Once Company B receives the merchandise it can query the location of the object information (RFID database and/or EPCIS of Company A) by accessing the object naming services (dotted arrows).

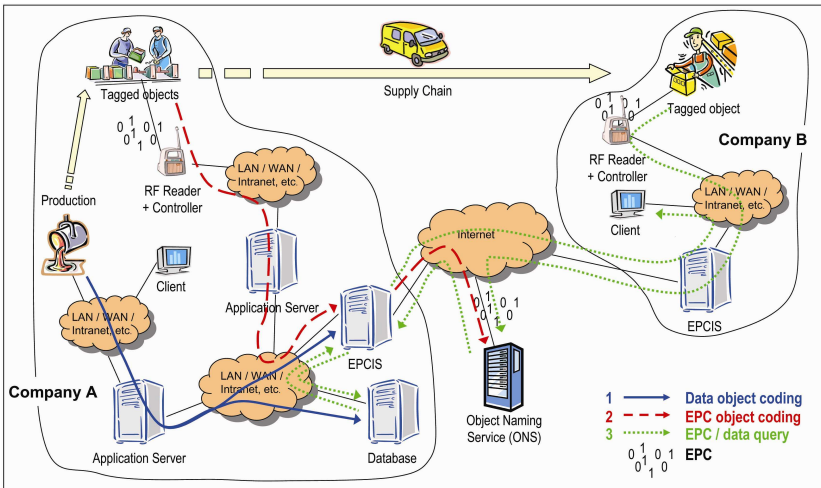

Fig. 1. Example of RFID-tagged object in EPCglobal Network (simplification)

2.1 RFID System

RFID is a technology that identifies objects by radio waves. In its simplest form, an RFID system comprises two main components (Finkenzeller, 2003): (i) a transponder (chip, tag or transducer) which represents the actual data-carrying device; and (ii) a reader which is capable of wirelessly identifying the information in the transponder.

In order for the end-user to be able to access and use the data of an RFID the following additional hard- and software is, in summary, necessary (Lahiri, 2006): (iii) a controller as an intermediary agent that

allows communication between reader and external entity; and (iv) a hard- and software system, comprising an interface system to the reader, middleware, and enterprise backend (hard- and software) with corresponding interfaces. The latter is the complete suite of systems and applications of the enterprise.

2.2 EPCglobal Network

The EPCglobal Network, consisting of an RFID system, the EPC, and supporting hard- and software based on EPCglobal standards, is a system for bringing together the benefits of RFID to the global supply chain. It does so by encoding a unique EPC in an RFID tag and by leveraging the Internet to access the associated information linked to the EPC (EPCglobal Inc., 2004).

The main goal of the EPCglobal Network is to connect its members to one single network and thereby to facilitate their exchange of information of (and objects in) the supply chain. Three key elements of this decentralised network are (i) the assignment of the EPC by the subscribers themselves (so-called EPC managers), (ii) the EPCIS which is the primary vehicle for data exchange, and (iii) the Object Naming Service which is the lookup service for facilitating an EPC query (Traub, 2005). This naming service is important because mostly the EPC does not contain any information about the object itself; information associated with this EPC is in the EPCglobal network (EPCglobal Inc., 2004), and within such network in the EPCIS and/or RFID database: The issuer of the product stores object information in the EPCIS and/or a database and provides the location of such data via the Object Naming Service. The receiver of the object containing the EPC encoded RFID can then access such object data by finding the location of the stored data through the Object Naming Service.

2.3 Database and DBMS

Data are given facts. A database is a collection of related and persistent data. These data or facts relate to someone or something, and they are persistent because once accepted by the DBMS they only can be deleted by specific request within the DBMS (Kifer, 2006; Date, 2000). The most common (but not only) database model is the relational database model as introduced by Codd (1970). "Relational"

means that data is represented in a table or various tables (Date, 2000). Each table consists of rows, also called tuples, and columns, also called attributes (Codd, 1990), whereby each tuple has the exact same number of columns, i.e., the same arity of the relation (Kifer, 2006). It is important to note that the order of tuples is irrelevant in a database. The relation is an unordered set which is needed for databases especially when they comprise many million tuples. Codd (1990) argued that "the user should not be burdened with either the numbering or the ordering of tuples [or] with having to remember which tuples are next to which [...]" (p. 2). In consequence, the organisation of data becomes independent of the order of tuples in storage and they can be changed without affecting the application programs. However, in order to unambiguously identify a tuple in a relation, it is common to designate a primary key to each row (Codd, 1990; Kifer, 2006).

A DBMS, on the other hand, is software designed to manage the handling of data. It provides for independent representation and storage of data from application programs (Ramakrishnan, 2000). Databases are not seldom encapsulated within a DBMS, enabling access to the data generally by queries (retrieve data) or by updates (insert, delete, modify data) (Kifer, 2006).

3 Analysis of RFID Databases in Light of Feist, CCH, and Horseracing / Fixtures

After laying out the technical cornerstones in the previous section, I will analyse and directly apply the rulings of the three landmark cases with regard to RFID databases in the EPCglobal Network. For purpose of this analysis I will assume that the information of an object is data of manufacture, lot number, expiration date (Traub, 2005), but also, for instance, size, colour, composition and price (herein referred to as object information).

3.1 EPCglobal Network Databases in the USA

3.1.1 Feist Publications, Inc. v. Rural Telephone Service Co.

The Copyright Law of the USA defines that "[a] 'compilation' is a work formed by the collection and assembling of pre-existing materials or of data that are selected, coordinated, or arranged in such a way that the resulting work as a whole constitutes an original work of authorship. The term 'compilation' includes collective works." (Copyright Act of 1976, §101).

In *Feist v. Rural* (1991) the Supreme Court of the USA clarified the extent of copyright protection moving away from the "sweat of the brow" doctrine of extending copyright to the facts themselves due to industriousness towards the "creativity" doctrine as outlined in the following.

Rural Telephone Service Company, a telephone service provider, by state regulation also published telephone white and yellow page directories. Feist Publications Inc., a publishing company specialised in area-wide telephone directories, used Rural's white page listings without Rural's consent. Rural sued for copyright infringement.

In delivering the court's opinion for *Feist v. Rural* (1991), Justice O'Connor first restated the copyright principles that facts are not but that compilations of facts are generally copyrightable, and second posed the question how compilations of mere raw data qualified for copyright. Factual compilations can meet the *sine qua non* of copyright, namely originality, if the choices of selection and arrangement are made independently by the compiler and entail some minimal degree of originality: "Where the compilation author adds no written expression but rather lets the facts speak for themselves, the expressive element is more elusive. The only conceivable expression is the manner in which the compiler has selected and arranged the facts. Thus, if the selection and arrangement are original, these elements of the work are eligible for copyright protection [...] This inevitably means that the copyright in a factual compilation is thin." (para. 17 & 18). The result being that facts contained in existing works may be freely copied because only elements that owe their origin to the compiler – selection, coordination and arrangement – are

protected by copyright. Rural's selection of names, towns and telephone numbers was ultimately dictated by state law and the alphabetical coordination and arrangement was not creative enough to be original and constitute copyright.

3.1.2 Analysis at DB Level

It seems difficult to dispute that the object information as well as the EPC are pure facts. As such they do not qualify for copyright protection. However, within factual compilations the test may be conducted as to whether the choices of selection and arrangement are made independently by the compiler and entail some minimal degree of originality. After all, the possibility of copyright in compilations is only thin, not impossible.

As designed by Codd (1970), the arrangement of tuples within a database is irrelevant. The order of data shall not burden the compiler. To such extent one must conclude that there is no arrangement of object data in a database underlying the EPCglobal Network. This leaves the selection of data of EPC tagged RFID objects the only remaining attribute to meet the *sine qua non* of copyright law, i.e., originality. The selection of the object information, however, does not seem to require much creativity either: first, the data to be compiled in the database will most probably be given by the information that is to be conveyed about such object. Thus, the creativity is attached to, e.g., the composition or production method of the object, and not to the selection of its (subsequent) attributes. And second, if the attributes about an object are not automatically given by the object itself but are at the compiler's discretion to select then I argue that the selection will nonetheless be non-creative because of the arity of the relation: each object will be described by the same attributes.

I therefore conclude that in the USA the object information in the RFID database in the EPCglobal Network is not original and in consequence is not protected by copyright.

3.2 EPCglobal Network Databases in Canada

3.2.1 CCH Canadian Limited v. Law Society of Upper Canada

Primary protection for compilations is provided by the Copyright Act (1985) which states in section 2 that "'compilation' means (a) a work resulting from the selection or arrangement of literary, dramatic, musical or artistic works or of parts thereof, or (b) a work resulting from the selection or arrangement of data;" and that "literary work' includes tables, computer programs, and compilations of literary works;" (Copyright Act of 1985).

In CCH v. Law Society (2004), the three publishers of law reports and other legal material, CCH Canadian Ltd., Thomson Canada Ltd. and Canada Law Book Inc., claimed that the Law Society of Upper Canada, the society maintaining and operating the Great Library at Osgood Hall in Toronto, was, *inter alia*, infringing the publishers copyrights when providing request-based photocopy and other services of the publishers' works to Law Society members, the judiciary and other authorized researchers.

The relevance of this case for the discussion of RFID at database level in the EPCglobal Network lies with the limitation of interpreting Canadian copyright law to be a *sui generis* type of copyright protection (see Section 3.3 below). Section 5 of the Copyright Act (1985) states that in Canada copyright shall subsist "in every original literary [...] work". Chief Justice McLachlin concluded that the interpretation of originality fell within the extreme positions of pure industriousness ("sweat of the brow" doctrine) and the necessity of creativity ("creativity" doctrine). For a work to be protected by copyright, the expression of an idea had to be an exercise of skill – i.e., the use of knowledge, developed aptitude or practised ability – and judgement – i.e., the capacity for discernment or ability to form an opinion or evaluation. In any case, however, the skill and judgment required to produce the work was not be so trivial to be characterised as a purely mechanical exercise (CCH v. Law Society, 2004).

Whereas an arranger of information does not have copyright in the individual components, the Supreme Court of Canada in its decision did acknowledge the copyright protection in the overall arrangement of

compilations. It decided that the publishers' headnotes, case summaries, topical indices and compilation of reported judicial decisions were all the product of exercise of non-trivial skill and judgment and thus original works protected by copyright. However, in this case the dealings of the Great Library were fair and did not infringe copyright (CCH v. Law Society, 2004).

3.2.2 Analysis at DB Level

Falling in between the extreme positions of the industriousness doctrine and the creativity doctrine, the prerequisites of the Canadian skill and judgment doctrine must by such median definition assumedly be less stringent than the current US requirement of originality. Does less stringent mean that the RFID database and/or EPCIS within the EPCglobal Network is automatically original? The answer is no. So what is needed? The compiler must use skill and judgment in the expression of an idea, i.e., in the compilation of the work.

It is possible that in an automatised enterprise environment with adequate middleware the existing object production data can be reused as information in the RFID database and/or EPCIS. In such case the compilation of data in the database seems purely mechanical since the data is merely transferred from one to another system. If the data is not merely transferred from one system to another, but the relevant data is specifically selected and arranged in a database, the question must be whether the compiler needs skill and judgment to express his idea of selection and arrangement. With regard to the arrangement one can refer to the analysis and conclusion in section 3.1.2 because the order of tuples in a database is irrelevant. With regard to the selection, however, the skill and judgment test must be conducted. In CCH v. Law Society (2004) the Supreme Court of Canada evaluated, *inter alia*, the headnotes, case summaries and topical indices to be original; the reason being that one needed skill and judgment to decide (i) which parts of a case to include in the headnote, (ii) which parts of a case to extract into a case summary, and (iii) which cases were authoritative to include in the topical index. But with regard to the requirement of skill and judgment for selecting the attributes of a database, I argue that a person does not need special capacity for discernment or ability to form an opinion. Whereas the headnotes, case summaries and topical indices translated into

database language correspond to the attributes of a database and as such do not need much skill and judgment to select, the underlying input to such attribute in each tuple requires the compiler to understand the judicial decision and use his or her knowledge about law to determine the legal ratio for each case. Compared to such judicial cases, the skill and judgment for selecting the object information, however, seems trivial.

Therefore, I conclude that in Canada the threshold set by the skill and judgment doctrine is not met for the object information in the RFID database and/or EPCIS of the EPCglobal Network and thus not original.

3.3 EPCglobal Network Databases in the European Union

3.3.1 British Horseracing and the Fixtures Cases

The Directive 96/9/EC protects copyright and provides for *sui generis* protection of databases (Articles 7-11, Chapter III). The *sui generis* protection of the Directive 96/9/EC focuses on the data and contents of the database. According to Article 7, the maker of the database, who can show that there has been substantial qualitative and/or quantitative investment in either obtaining, verifying or presenting of the data shall be protected from extraction and/or re-utilisation of the whole or of a substantial part of the database.

On November 9, 2004, the European Court of Justice (ECJ) dealt simultaneously with four cases concerning the protection of databases: *Horseracing v. William Hill* (2004), *Fixtures v. Oy Veikkaus* (2004), *Fixtures v. Svenska* (2004), and *Fixtures v. OPAP* (2004) respectively. These cases involve equestrian and football sports organisations filing claims for infringement of *sui generis* rights against various sports bookmakers: in *Horseracing* the defendant William Hill allegedly displayed names of horses in races, racecourse, date and time of race compiled by the claimants on its Internet site; in the three *Fixtures* cases the defendants Svenska Spel, Veikkaus and OPAP were allegedly reproducing fixture lists of the claimant Fixtures Marketing Ltd on coupons and websites. All four courts deciding on these cases (UK, Sweden, Finland, and Greece) sought, *inter alia*,

clarifying interpretation of section 7 of the Directive 96/9/EC by the ECJ.

In its decisions the ECJ held that the expression "obtaining" in section 7(1) of the Directive 96/9/EC must be understood to "refer to the resources used to seek out existing independent materials and collect them in the database, and not to the resource used for the creation as such [...] The purpose [...] is to promote the establishment of storage and processing systems for existing information and not the creation of materials [...]" (Horseracing, para. 31; Veikkaus, para 34; Svenska, para. 24; and OPAP, para. 40) This means that investments in seeking existing information are protected, but not such investments in the creation of information. Consequently, the right attached to the "verification" according to section 7(1) does not cover resources used in creating the database either (Horseracing, para. 34; Veikkaus, para. 37, Svenska at 27; and OPAP, para. 43) And finally the ECJ interpreted the investment in "presentation" according to section 7(1) as being the "resources used for [...] the systematic or methodical arrangement of the materials contained in the database and the organisation of their individual accessibility." (Veikkaus, para. 37; Svenska, para. 27; and OPAP, para. 43) However, the court distinguished that creating a database should be protected by *sui generis* right as long as the aforementioned three requisites of obtaining, verifying and presenting require substantial investment.

In a nutshell, the ECJ ruled in all four cases that the horse and football fixture lists respectively, did not constitute sufficient investment in obtaining, verifying and presenting (only Fixtures cases) the data of the databases.

3.3.2 Analysis at DB Level

Being introduced under various premises, such as (i) insufficient protection in all member states, (ii) high costs of human, technical and financial investment, or (iii) great imbalance in the level of investment in the database sector within the EU and between the EU and the world's largest database-producing countries (Directive 96/9/EC, Recitals), one could assume that databases underlying the EPCglobal Network are covered by *sui generis* right. In light of the 2004

Horseracing / Fixtures decisions, however, this does not seem to be the case.

Two different cases are relevant, whereby for the first case I will assume that the middleware of the producing enterprise in the supply chain allows interfacing of the relevant data from the production systems to the RFID database and/or EPCIS. Whereas one can argue that such transfer of production data to the RFID database and/or EPCIS is seeking out existing material because it is already in the production systems, neither is such material independent nor is the investment in obtaining (i.e., automatic data transfer) qualitatively or quantitatively substantial. In the second case where the data is not automatically, but specifically selected and arranged, I argue that the database is actually being created. And since the ECJ ruled that the investment in obtaining data does not cover the creation, the RFID database and/or EPCIS is not protected by *sui generis* right.

Similar situation arises with the investment in verification: In the first case where the data is transferred from one system to another, there is no substantial qualitative or quantitative investment in verification. The transferred data is the same as the original data and the costs of copying intellectual property is generally negligible (as compared to the initial creation costs). In the second case the investment in verification follows by ECJ ruling the investment in obtaining the database: no *sui generis* protection for verification of a database that is being created.

And finally, the presentation of the data is managed through the DBMS. The resources for the systematic or methodical arrangement of the materials contained in the database and the organisation of their individual accessibility relate to the DBMS. The DBMS is closely linked to the creation of the database. Thus, similar to the verification, it cannot be considered to require investment independent of the creation investment.

Therefore I conclude that in the European Union the object information in RFID databases and/or EPCIS is not protected by *sui generis* right.

4 Conclusion

In analysing the RFID, the database and EPCIS in the EPCglobal Network in view of the three landmark cases *Feist v. Rural* (1991), *CCH v. Law Society* (2004) and *Horsereading v. William Hill / Fixtures cases* (2004) I have shown that the compilation of data in databases lacks (i) creativity (USA), (ii) requires no skill or judgment (Canada) or (iii) does not qualify as creation of the database (European Union). This leads to the conclusion that RFID databases and/or EPCIS in the EPCglobal Network are protected neither in the USA, nor in Canada, nor in the European Union.

For enterprises joining the EPCglobal Network either in providing or in tracking RFID-tagged objects in the supply chain this means that to date such enterprises seem to be free in selecting their location for their RFID databases and/or EPCIS. From a database protection perspective there is no strategic advantage in either of the analysed countries.

References

- CCH Canadian Ltd. v. Law Society of Upper Canada*, 2004 SCC 13.
- Codd, E. F. (1990) *The Relational Model for Database Management* (Version 2 ed.), Addison-Wesley Publishing Company, Reading, Massachusetts.
- Codd, E. F. (1970) 'A Relational Model of Data for Large Shared Data Banks', *Communications of the ACM*, Vol. 13, No. 6, p. 377.
- Copyright Act, R.S.C. 1985, c. C-42.
- Copyright Act, 17 U.S.C. §§ 101, 103 (1976).
- Date, C. J. (2000) *An Introduction to Database Systems* (8th ed.), Addison-Wesley, Boston, Massachusetts.
- EC, Directive 96/9/EC of the European Parliament and of the Council of 11 March 1996 on the Legal Protection of Databases, O.J. L. 77/20 U.S.C. (1996).
- EPCglobal Inc. (2004) 'The EPCglobal network: Overview of design, benefits, & security', No. 008186, Lawrenceville, New Jersey.

- Feist Publications, Inc. v. Rural Telephone Service Company, Inc.,
499 U.S. 340 (1991).
- Finkenzeller, K. (2003) RFID Handbook – Fundamentals and
Applications in Contactless Smart Cards and Identification (2nd
ed.), Wiley, West Sussex, England.
- Fixtures Marketing Ltd v. Organismos Prognostikon Agonon
Podosfairou AE (OPAP), (C-444/02) 2004).
- Fixtures Marketing Ltd v. Oy Veikkaus AB, (C-46/02) 2004).
- Fixtures Marketing Ltd v. Svenska Spel AB, (C-338/02) 2004).
- Kifer, M., Bernstein, A. & Lewis, P. M. (2006) Database Systems. An
application-oriented Approach (2nd ed.), Pearson Addison
Wesley, Boston, Massachusetts.
- Lahiri, S. (2006) RFID Sourcebook, IBM Press, Upper Saddle River,
New Jersey.
- Ramakrishnan, R. & Gehrke, J. (2000) Database Management
Systems (2nd ed.). Boston, Massachusetts: McGraw Hill.
- The British Horseracing Board Limited and Others v. William Hill
Organization Ltd, (C-203/02) 2004).
- Traub, K., et al. (2005) 'The EPCglobal Architecture Framework',
EPCglobal Final Version of 1 July 2005.

2. MARKETING ARTICLE

Why Marketing Short-Range Devices as Active Radio Frequency Identifiers Might Backfire

Daniel Ronzani

The Internet of Things, LNCS 4952,
Springer, Berlin Heidelberg 2008, pages 214 – 229.

Reprint and publication of author generated version of the article with courtesy of Springer-Verlag GmbH (22 October 2009). Copyright with Springer-Verlag GmbH.

Changes to format and references.

Why Marketing Short-Range Devices as Active Radio Frequency Identifiers Might Backfire

Daniel Ronzani

Centre for Applied ICT, Copenhagen Business School

Howitzvej 60, 2000 Frederiksberg, Denmark

dr.inf@cbs.dk

Abstract

This paper analyses why marketing short-range devices (SRD) as radio frequency identifiers (RFID) might backfire on the RFID industry. To support this claim it provides a legal use case as basis and gives an overview of selected technical parameters of RFID. Furthermore an analysis of 43 legal articles shows that legal experts perceive the technology of RFID in an undifferentiated way. Finally an analysis of 11 tag providers of so-called “active RFID tags” shows that SRD are marketed as active RFID. It concludes that in order to avoid inhibiting legal consequences which might have negative effect on the RFID industry a differentiated approach regarding the functionality of short-range transmitters and RFID is necessary.

Keywords

Radio frequency identification (RFID), short-range device (SRD), passive tag, active tag, law, industry.

1 Introduction

This paper analyses the legal perception and technical use of so-called “active” radio frequency identification (RFID) tags. It is of value not only to the legal community to clarify and differentiate the technology of RFID but also to the RFID industry in that it assumes that marketing short-range transmitters as active RFID tags could be counter-productive to the RFID industry after all.

Admittedly, the understanding of RFID technology is not always clear. For instance, there is a narrow and a wide understanding of what an active RFID tag is insofar as short-range transmitters are also marketed as RFID. Therefore the question about an accurate and also differentiated understanding of RFID technology in the legal discussion becomes crucial. Whereas the RFID industry includes short-range transmitters in the product line of RFID to increase sales, the legal consequences of merging the functionalities of both RFID and short-range devices (SRD) might lead to a restrictive legal interpretation and understanding of RFID because the technical features of SRD are broader than those of RFID.

First, a legal use case is presented as basis for the subsequent legal and technical analysis (section 2). Second, an overview of RFID technology with regard to tag functionality, energy supply and coupling is given in section 3 to set the technical ground in the discussion of RFID and SRD. Third, an analysis of 43 journal articles shows the legal perception and understanding of RFID technology between 2001 and 2007 (section 4). Fourth, an industry analysis with an empirical sample of 11 providers of so-called “active” RFID tags illustrates how the RFID industry is marketing SRD as RFID (section 5). This paper concludes by suggesting that the industry’s approach of marketing short-range transmitters as RFID could backfire on the industry (section 6).

2 Use Case

The use case selected to support the claim of this paper is taken from the empirical sample provided in section 3.1. It illustrates why it makes a difference to discriminate RFID tag functionality.

Dalal [5] examines the use of RFID technology in various contexts and privacy invasions. The use case of this paper focuses especially on the potential use of RFID and the Fourth Amendment of the Constitution of the USA [29] which stipulates that it is “[t]he right of the people to be secure in their persons, houses, papers, and effects against unreasonable searches and seizures [...]” [29]. There has been extensive ruling on this topic with the following four landmark cases on telephony, radio transmitter and thermal imaging surveillance:

1. In *Olmstead v. United States* [22] the plaintiff(s) was (were), among others, convicted of violating the National Prohibition Act [21] for unlawfully possessing, transporting and importing intoxicating liquors. The (divided) US Supreme Court held that evidence collected by wiretapping telephone lines did not violate the Fourth Amendment because “[t]he language of the amendment cannot be extended and expanded to include telephone wires” [22]. The wiretapping had been effectuated without a physical trespass by the government, and was thus legally obtained.
2. In 1967 the US Supreme Court overruled its decision in *Olmstead* [22]. In *Katz v. United States* [15] the court argued that evidence overheard by FBI agents who had attached an electronic listening and recording device to the outside of a public telephone booth from which the plaintiff had placed his calls for bets and wagers in violation of the Criminal Law was searched unconstitutionally. Whether a given area was constitutionally protected deflected attention from the problem presented, as the Fourth Amendment protected people, not places: “[...] the Fourth Amendment protects people – and not simply ‘areas’ – against unreasonable searches and seizures [...] so] it becomes clear that the reach of that Amendment cannot turn upon the presence or absence of a physical intrusion into any given enclosure.” [15]
3. In 1983 the US Supreme Court ruled on a Fourth Amendment Case that monitoring the progress of a car carrying a container with a “beeper” (i.e., a battery operated radio transmitter which emits periodic signals that can be picked up by a radio receiver) did not violate the defendant’s constitutional rights. In *United States v. Knotts* [30] the court decided that monitoring the beeper

signals did not invade any legitimate expectation of the defendant's privacy because there was a diminished expectation of privacy in an automobile: "One has a lesser expectation of privacy in a motor vehicle because its function is transportation and it seldom serves as one's residence or as the repository of personal effects. A car has little capacity for escaping public scrutiny. It travels public thoroughfares where both its occupants and its contents are in plain view." [4]

4. Finally, in *Kyllo v. United States* [19], the US Supreme Court ruled in a case of thermal heating surveillance that use of thermal imaging devices to gather information about heat in a house's interior is not removed from scope of Fourth Amendment search merely because the device captures only heat radiating from external surface of a house, and thus involves "off-the-wall" rather than "through-the-wall" observation. In this case agents of the United States Department of the Interior suspected that marijuana was being grown in the petitioner's home. The court argued that where "the Government uses a device that is not in general public use, to explore details of a private home that would previously have been unknowable without physical intrusion, the surveillance is a Fourth Amendment "search," [sic!] and is presumptively unreasonable without a warrant." [19]

To date there have been no Supreme Court rulings on RFID surveillance. However, spinning forth the courts' present decisions, Dalal [5] argues that among the many factors to be considered in a potential RFID ruling, RFID searches are likely to be found constitutional under the Fourth Amendment because "tracking devices in public places are not considered to violate an objective expectation of privacy". [5]

After having provided the use case in this section an overview of selected technical parameters necessary for the subsequent analysis is discussed in the next section.

3 Technical Parameters

This section covers the technical parameters of RFID technology. An overview of these parameters is important to understand the inaccuracy in legal analyses (section 4) and to better understand the industry approach (section 5).

According to Kern [16], Finkenzeller [11] and Glover [12] the most common classifications for RFID are:

Differentiator	Characteristics		
Frequency	<i>Low frequency</i> (30 – 300 kHz)	<i>High frequency</i> (3 – 30 MHz)	<i>UHF (300 MHz – 3 GHz) and Microwave (> 3 GHz)</i>
Memory and data	1-bit (no chip)	n-bit (chip with ID)	
Energy supply chip	<i>Passive</i>	<i>Semi-active/passive</i>	<i>Active</i>
Communication	Full Duplex	Half Duplex	Sequential
Coupling	<i>Capacitive (electrical) coupling</i>	<i>Inductive coupling</i>	<i>Backscatter coupling</i>
Read range	<i>Close proximity):</i> $\approx < 1\text{cm}$	<i>Remote (or vicinity):</i> $\approx 1\text{cm} - 1\text{m}$	<i>Long Range:</i> $\approx > 1\text{m}$
Antenna	<i>Coil</i>	<i>Ferrite</i>	<i>Dipole</i>

Table 1: Differentiators of RFID according to Kern [16], Finkenzeller [11] and Glover [12] (adapted). Characteristics that are italicized often but not necessarily (or solely) group in the vertical.

A more detailed explanation follows for the energy supply of RFID tags (section 3.1), and the way they broadcasts to the reader (section 3.2).

3.1 Energy Supply

Three types of transponders vary in energy supply: passive, semi-active/semi-passive, and active RFID tags. It is important to note and here it is argued that the common division of tags by energy supply – i.e., passive tags without own energy supply and active tags with their

own energy supply for the chip in the tag (for example batteries or solar cells) – has nothing to do with the transmission of data from the transponder to the reader. In either case the tag needs the energy of the reader to transmit the data.

Active transponders use their own power source only to supply the chip in the tag with energy and not to transmit the data from the transponder to the reader. The advantage of an own power supply in active tags is that all energy from the reader can be used for data transmission because the chip is already supplied with energy by a separate source (e.g., battery). This dual energy supply has positive effects on the read range because all energy derived from the reader can be used for transmission and no energy is lost for powering the chip. [11] [16] Active RFID tags – herein understood as active RFID tags in the narrow sense according to Finkenzeller [11] – do not have the capability of emitting their own high frequency signal. According to Finkenzeller [11] transponders with the capability of emitting an own frequency signal are not RFID transponders but rather SRDs. These devices emit their own high frequency electro-magnetic field without influencing the field of the reader. [11] Bensky [2] makes the same differentiation:

“A quite different aspect of the data source is the case for RFIDs. Here the data are not available in the transmitter but are added to the RF signal in an intermediate receptor, called a transducer. [...] This transducer may be passive or active, but in any case the originally transmitted radio frequency is modified by the transducer and detected by a receiver that deciphers the data added [...] A basic difference between RFID and [transmitter - receiver] is that RFID devices are not communication devices per se but involve interrogated transponders.” (Bensky [2])

Glover et al. [12] acknowledge the differentiation of power source for passive and active tags. Traditionally active tags use the internal energy source to power the chip and the reader to power communication. However, these authors opt to use the term semi-passive for tags that only use the internal power supply to feed the chip (or other devices) but not for communication. [12]

A further source of definitions for passive, semi-passive/semi-active and active RFID tags is EPCglobal Inc.¹⁰ and RFID Journal¹¹. EPC Global and RFID Journal discriminate the following functionalities of the different tag types in Table 2.

Source	Type	Tag definition and functionality
EPCglobal Inc.	Passive tag	“RFID tag that does not contain a power source. The tag generates a magnetic field when radio waves from a reader reach the antenna. This magnetic field powers the tag and enables it to send back information stored on the chip.” [43]
	Semi-passive/ semi-active tag	“A class of RFID tags that contain a power source, such as a battery, to power the microchip’s circuitry. Unlike active tags, semi-passive tags do not use the battery to communicate with the reader. Some semi-passive tags are dormant until activated by a signal from a reader. This conserves battery power and can lengthen the life of the tag.” [43]
	Active tag	“A class of RFID tag that contains a power source, such as a battery, to power the microchip’s circuitry. Active tags transmit a signal to a reader and can be read from 100 feet (35 meters) or more.” [43]

[continued on next page]

¹⁰ <http://www.epcglobalinc.org> (last visited December 9, 2007). EPCglobal Inc. is a leading organisation for the industry-driven standards of the Electronic Product Code (EPC) to support RFID.

¹¹ <http://www.rfidjournal.com> (last visited December 9, 2007).

Source	Type	Tag definition and functionality
RFID Journal	Passive tag	An RFID tag without its own power source and transmitter. When radio waves from the reader reach the chip's antenna, the energy is converted by the antenna into electricity that can power up the microchip in the tag. The tag is able to send back information stored on the chip. [...]"[44]
	Semi-passive/ semi-active tag	"Semi-passive tags are"[s]imilar to active tags, but the battery is used to run the microchip's circuitry but not to broadcast a signal to the reader. Some semi-passive tags sleep until they are woken up by a signal from the reader, which conserves battery life. Semi-passive tags can cost a dollar or more. These tags are sometimes called battery-assisted tags." [44]
	Active tag	"An RFID tag that has a transmitter to send back information, rather than reflecting back a signal from the reader, as a passive tag does. Most active tags use a battery to transmit a signal to a reader. However, some tags can gather energy from other sources. Active tags can be read from 300 feet (100 meters) or more [...]" [44]

Table 2: Selected definitions of RFID functionalities.

EPCglobal Inc. and the RFID Journal also define SRD as active RFIDs (Table 2): First, the definitions of semi-active/semi-passive tags by both EPC Global and RFID Journal stipulate that these tags use their battery to power the chip's circuitry. Second, EPC Global states that "[u]nlike active tags, semi-active tags do not use the battery to communicate with the reader". This means e contrario that these active tags use the battery power to broadcast the signal. Furthermore, EPCglobal's definition of active tags states that they

transmit a signal to the reader. Third, the RFID Journal defines the active RFID tag to include a “transmitter to send back information, rather than reflecting”. These definitions of semi-active/semi-passive tags and active tags also clearly show that (i) active tags as understood by Finkenzeller [11] and Kern [16] are referred to as semi-active/semi-passive tags by EPCglobal and RFID Journal (and Glover [12] respectively); and that (ii) active tags as understood by EPCglobal and RFID Journal (and Glover [12] respectively) are referred to as SRDs by Finkenzeller [11] and Bensky [2].

Based on the differentiation between these three different RFID tag types, the next subsection explains how passive and active RFID tags as understood in the narrow sense by Finkenzeller [11] and Kern [16] derive the necessary power for transmission of the data.

3.2 Coupling

The following subsection introduces the technology of coupling. It gives a brief technical overview on how energy is derived from radio waves of a reader to power an RFID tag. This understanding is necessary to differentiate between energy supply and data transfer to the reader as discussed in the industry review (section 5.2).

Coupling is the mechanism by which a transponder circuit and a reader circuit influence one another for energy supply of the transponder as well as for data transfer to the reader. There are three main coupling modes: inductive coupling, capacitive coupling and backscatter coupling.

First, transponders of inductive coupling systems are mostly only used in passive tags. The reader must provide the required energy for both the data signal as well as for the operation of the chip. The inductively coupled transponder usually comprises a chip and an antenna coil. The reader’s antenna generates an electromagnetic field. When a tag is within the interrogation zone of a reader the tag’s antenna generates voltage by electromagnetic induction which is rectified and serves as power supply for the chip. The data transfer back to the reader works by load modulation: When a resonant transponder is within the range of the electromagnetic field it absorbs and reduces the energy of the reader’s magnetic field which can be represented as change of impedance. Switching on and off a load resistor by the

transponder also can be detected by the reader. The course of this change allows the interpretation of a signal (data transfer). [11] [16]

Second, capacitive coupling systems use plate capacitors for the transfer of power from the reader to the transponder. The reader comprises an electrode (e.g., metal plate). Through the very precise placement of the transponder on the reader a functional setup similar to a transformer is generated. If high-frequency voltage is applied to this electrically conductive area of the reader, a high frequency field is generated. Electric voltage is generated between the transponder electrodes if the transponder is placed within the electrical field of the reader. This electrical voltage supplies the transponder with power. Similar to load modulation of inductive coupling, the read range of a reader is dampened when an electrically coupled tag is placed within the resonant circuit. This allows switching on and off of the modulation resistor (data transfer). [11]

Last, long distance backscatter systems are often active (in the narrow sense) or semi-passive (in the wide sense) tags, i.e., they are supported by an additional energy source for the chip within the transponder. The source energy for the transponder emitted by the reader is partly reflected by the transponder and sent back to the reader. Backscatter coupling is based on the principle of radar technique that electromagnetic waves are reflected by objects with dimensions larger than half the length of a wave. Also in this coupling mode a load resistor is switched on and off in time to transmit data from the transponder to the reader, thereby modulating the amplitude of the reflected power (modulated backscatter). [11] [16]

4 Legal Analysis

The two previous sections have introduced the use case and provided the technical background on energy supply and coupling of RFID. This section presents an empirical sample of legal journals and reviews the technical understanding by legal experts. It forms the legal basis of the claim that marketing SRD as RFID might backfire on the RFID industry.

4.1 Research Method and Legal Empirical Sample

The legal articles that form the basis for the empirical sample have been searched and selected in the WestLaw¹² and LexisNexis¹³ databases. Both databases are leading providers of comprehensive legal information and business solutions to professionals. Two queries were conducted in each legal database. The parameter set in both databases for retrieval used the following keywords: radio frequency ident* (as group word and truncated using a wild card to allow variances such as identification or identifiers) and RFID (the acronym for radio frequency identification). Within Westlaw and LexisNexis the search was conducted in the database for combined journals and law reviews. Apart from searching for articles containing the keywords listed above, a filter was set by searching articles written in English and limited to the regions North America and Europe.

As both legal databases have similar but not identical content some results overlapped. After manually sifting out the duplicates of both databases, 141 legal journal articles, reviews and reports dating from 1997 to several months into 2007 remained (gross sample). Almost 80 per cent of the selected articles date back to the years 2005 and 2006. From the total 141 retrieved articles some 98 articles were excluded because a full text analysis showed neither their main nor side content relates specifically to the technology of RFID. The 98 excluded articles in many cases only mention RFID as an example in one sentence, part of a sentence or footnote. These 98 articles do not have any in-depth relation to RFID, explanation or analysis of RFID technology. A total of 43 articles were selected for this analysis (net sample). These selected articles have either a (sub-) chapter dedicated to RFID technology or comprise RFID as secondary content in either main text or footnotes with technological and/or legal analysis of RFID (as compared to the excluded 98 articles).

The year 2001 has 1, the year 2004 has 3, the years 2005 and 2006 each have 17 and 2007 (not full year) has 5 in scope articles. Most in scope articles are found in legal journals, reviews and reports for Information and Communication Technology law (42%). General legal

¹² <http://www.westlaw.com> (accessible only with license; last visited May 18, 2007).

¹³ <http://www.lexisnexis.com> (accessible only with license; last visited May 18, 2007).

journals and legal policy journals account for another third (30%). The remaining selected articles relating to RFID (28%) are distributed among administrative/public law, finance law, food and drugs reports, human rights law, intellectual property law, lawyer associations, and procurement law.

In summary, the large part of the 43 legal articles researched for this analysis has a similar structure. The articles mostly comprise (i) an introduction, followed by (ii) a technical description, (iii) a legal analysis and lastly (iv) a conclusion. Other articles explain the technical advancements of RFID only in footnotes. Within the technical description many authors recall the history of RFID as far back as World War 2, differentiate between passive and active tags, and provide a few examples of RFID implementation.

It is recognised that there are several limitations to the proposed methodology. First, the search is limited to two legal databases. Second, English language articles are relied upon exclusively which introduce a certain bias regarding countries, especially in Europe. Lastly, no quality assessments regarding the type of law journal is made. Despite these possible sources of error, it is suggested that analysing these 43 articles is a reasonable method for conducting the proposed analysis of the technical RFID understanding legal articles.

4.2 Legal Review

This section reviews the technical RFID understanding and perception of legal experts based on the legal empirical sample.

Of the 43 in scope legal journal articles a little less than 50 per cent differentiate between passive, semi-passive/semi-active tags and active tags: Two articles use the functionality for tags in the narrow sense according to Finkenzeller [11] and Kern [16], thirteen articles refer to the functionality in the wide sense according to Glover [12], and five articles are inexplicit in the definition of the active tag (i.e., narrow or wide sense).

Both Landau [20] and Smith [23] mention the necessity of the active tag first being activated to transmit the data to the reader regardless of whether they have a battery or not. This makes them active according to Finkenzeller [16] or semi-active/semi-passive according to Glover [12]. Unclear remain the technical statements of Brito [3], Thompson

[28], Eng [9], Kobelev [17], and Eleftheriou [8]. These five authors mention (active) tags with batteries or tags that are self-powered, but do not explain whether such energy is also used to transmit the data or whether transmission power is generated by the reader.

Stark [25], Delaney [6], Terry [27], Eschet [10], Asamoah [1], Herbert [14], and Smith [24] not only refer to the necessity of a battery (or other power supply) in an active tag, but more importantly consider such power supply essential for the transmittal of the data to the reader. Other authors like Eden [7], Willingham [31], and Stein [26] especially emphasise the lack of need for an active tag to be within activation range of a reader. Such tags continuously transmit their data. The tag range referred to by Eden, Willingham and Stein is only exceeded by tags as mentioned by Handler [13] and Koops [18] with transmitters capable of sending the signal over up to several kilometres. The tags as referred to by these ten authors are active tags by definition of Glover [12] and SRD as understood by Finkenzeller [11] and Bensky [2].

With passive tags there is no doctrinal or industry driven differentiation similar to the one with active and semi-passive/semi-active tags. In principle all reviewed authors agree that passive tags do not have an internal power supply and transform the (electromagnetic) waves of the reader by induction. Many reviewed authors explicitly mention the lack of battery supply and/or the energy powering by the reader. Thompson et al. [28] also refer to the virtually unlimited operational life of a passive tag whereas Smith [24] inaccurately states that a passive tag cannot be turned off. Indeed the opposite applies: a passive tag is always off and needs external manipulation to be “switched on” by influence from the reader. If at all, it would be more accurate to envision the metaphor of active tags (as defined by Finkenzeller) or semi-passive tags (as defined by Glover) being “woken up”.

5 Industry Analysis

This section analyses the RFID industry by first providing an empirical sample of the active tag providers and then by reviewing the active RFID tag providers’ marketing strategy.

5.1 Research Method and Industrial Empirical Sample

Similar to the legal analysis an empirical sample is drawn for the industry analysis. The Buyer's Guide 2007 online database¹⁴ of the RFID Journal has been searched for industry suppliers of active RFID tags. The RFID Journal claims to be the only independent media company devoted solely to RFID and its many business applications. Its mission is to help companies use RFID technology to improve the way they do business.

Two queries were conducted for this empirical sample of industry suppliers of active RFID tags. The search parameters were set to search the RFID Journal Buyer's Guide 2007 database by type of technology (e.g., passive or active tag). In addition, a geographical filter was set to limit the search to the US and to Europe respectively.

The database search for the US market provided 104 hits; the database search for the European market provided 72 hits. A manual comparison of these 176 query hits resulted in an overlap of 64 resources (i.e., RFID providers based in both the USA and in Europe). Subsequently, the product range of these 64 RFID providers was analysed (gross sample). They offer, among others, tag hard- and software, readers, printers, and services such as consulting and system integrations. To qualify in the empirical sample of this analysis the provider must supply active RFID tags and issue a tag datasheet (PDF or html format) for evaluation and verification of the tag parameters. A total of 16 providers meet these selection criteria: AAiD Security Solutions¹⁵, AeroScout¹⁶, Access¹⁷, Deister Electronic¹⁸, Ekahau¹⁹, Identec Solutions²⁰, Multispectral Solutions²¹, RF Code²²,

¹⁴ <http://www.rfidjournal.com/article/findvendor> (last visited December 9, 2007).

¹⁵ <http://www.autoaccessid.com> (last visited December 9, 2007).

¹⁶ <http://www.aeroscout.com> (last visited December 9, 2007).

¹⁷ <http://www.axcessinc.com> (last visited December 9, 2007).

¹⁸ <http://www.deister.com> (last visited December 9, 2007).

¹⁹ <http://www.ekahau.com> (last visited December 9, 2007).

²⁰ <http://www.identecsolutions.com> (last visited December 9, 2007).

²¹ <http://www.multispectral.com> (last visited December 9, 2007).

²² <http://www.rfcode.com> (last visited December 9, 2007).

RFID Inc.²³, RFind²⁴, Savi²⁵, Smartcode²⁶, Synometrix²⁷, Tagmaster²⁸, Ubisense²⁹, and Wherenet³⁰.

It is also acknowledged in this empirical sample that there are several limitations to the proposed methodology. First, the search is limited to the online database of the Buyer's Guide 2007 offered by the RFID Journal. Second, the search is geographically limited to fit the legal empirical sample (North America and Europe). This excludes providers in other regions of the world like South America, Africa and Asia Pacific. Lastly, only tag providers with a datasheet for evaluation of the technology are included in the sample. Despite these possible biases it is suggested that analysing the RFID tags of these providers is a reasonable method for conducting the proposed analysis of the marketing approach of the RFID industry.

5.2 Industry Review

The selected technical parameters in the previous section 3.1 have shown that technically there is a difference between RFID and SRD. Whereas Finkenzeller [11] and Bensky [2] argue in favour of a strict differentiation of these technologies, Glover et al. [12] concede this distinction as accurate but opt to lump active RFID and SRD together under the term active RFID. These authors leave the traditional path of distinguishing the energy for the chip and energy for broadcasting, and use the term active RFID as synonym for SRD. The industry also seems to follow the wider functionality of active RFID tags.

²³ <http://www.rfidinc.com> (last visited December 9, 2007).

²⁴ <http://www.rfind.com> (last visited December 9, 2007).

²⁵ <http://www.savi.com> (last visited December 9, 2007).

²⁶ <http://www.smartcodecorp.com> (last visited December 9, 2007).

²⁷ <http://www.synometrix.com> (last visited December 9, 2007).

²⁸ <http://www.tagmaster.com> (last visited December 9, 2007).

²⁹ <http://www.ubisense.net> (last visited December 9, 2007).

³⁰ <http://www.wherenet.com> (last visited December 9, 2007).

Tag name	Tag feature as stated in the online datasheets
AAiD AA-T800	“The AutoAccess AA-T800 Long Range Tags are designed for high value asset identification, realtime loss prevention, inventory management and tracking applications. [It features] low power consumption. Tag life is estimated at 5-7 years when transmitting at 1.5 second intervals.” [32]
AeroScout T3 Tag	“The AeroScout T3 Tag is the most advanced Wi-Fi based Active RFID tag on the market, from the market leader in the Wi-Fi-based Active RFID industry. The T3 Tag is a small, battery-powered wireless device for accurately locating and tracking any asset or person. [The t]ransmission interval [is] programmable [from] 128 msec to 3.5 hours.” [33]
AXCESS ActiveTag Container Tag	“The AXCESS Container Tag provides a low cost solution for improving cargo container security, efficiency of movement and tracking capabilities while ensuring the integrity of the cargo within shipping containers. It uses the AXCESS ActiveTag™ RFID technology. [...] Under normal conditions the container tag will ‘beacon’ to the AXCESS system, letting the system know the tag is still in place.” [34]
Multispectral Model Sapphire Vision	“Multispectral Solutions’ Sapphire VISION puts this unique technology to work for active RFID applications [with a t]ag battery life in excess of 5 years (at one update per second).” [35]
RF Code M100 Active RFID Tag	“RF Code designs and manufactures active Radio Frequency Identification (RFID) monitoring systems that utilize beacon tags that periodically broadcast their status using encoded radio transmissions. [...] Every tag broadcasts its unique ID and a status message at a periodic rate (that is programmed at the factory). [...] Motion activated tags can be programmed to operate at 2 beacon rates: slow when the tag is stationary, and faster when the motion sensor is activated (to provide immediate notification when objects are moving).” [36]
RFID Inc. EXT1 Personnel Tag	“Our Extend-a-Read product is based on 433 MHz active (battery powered) anti-collision (read many simultaneously) Tags. Tags simply emit a data signal every 1.8 to 2.2 seconds which is picked up by the Reader.” [37]

[continued on next page]

Tag name	Tag feature as stated in the online datasheets
RFind active RFID Talon Tag	"The RFind active RFID Talon Tag is a core component of our 3-element 915MHz RTLS architecture. [...] Battery Lifetime: 5 years @ 400 communication events per day." [38]
SaviTag ST-656	"The SaviTag™ ST-656 is an innovative, data rich, active RFID tag for ISO containers, enabling shippers, carriers and logistics service providers to monitor their shipments in realtime as they move through the global supply chain. [One of the key features is the] UHF transmitter to transmit alarms, <i>beacon</i> and Savi Reader Interrogation Responses." [39]
SynoTag SMPTK-002	"Read Write Active RFID Tag with LED. [This] tag transmits <i>signal to reader every 300ms - 500 ms.</i> " [40]
Ubisense Compact Tag	"The Compact Tag is a small, rugged device that, when attached to assets and vehicles, allows them to be dynamically located to a precision of 15cm in 3D. [Power supply & battery life last o]ver 5 years at a continuous 5 second <i>beacon rate.</i> " [41]
WhereTag III	"The WhereTag III is [...] a small device that can be attached to assets of many kinds, [and i]t is used to manage those assets by allowing them to be identified and located by the system. The WhereTag III ' <i>blinks</i> ' an RF transmission at pre-programmed rates ranging from 5 seconds to one hour between blinks [with a] User Configurable Blink Rate of 5 sec to 1 hr." [42]

Table 3: Selected short-range transmitters with features [own emphasis].

From the total of 16 active tag providers selected in the empirical sample (footnotes 5 through 20) five are eliminated from the count. Although they meet the selection criteria ("active" RFID tag and online datasheet) it is not clear from the datasheet description whether they broadcast automatically to the reader or not. From the remaining eleven active tag datasheets (net sample) eight refer explicitly to the marketed tag as "active tag" (or similar), whereas all eleven datasheets include the feature of self-dynamic signal transmission to the reader, i.e., these tags beacon or blink periodically. The RFID tags offered by these providers include the following features as outlined in Table 3. Only one example is presented per tag provider even if its product line includes more than only "active" tag.

Here it is argued that the RFID tags marketed by these suppliers are SRD. Whereas all eleven tags contain a battery equally to the active RFID tags in the narrow sense referred to by Finkenzeller [11], Kern [16] and Bensky [2], the RFID tags by the providers listed in Table 3 continually and indiscriminately broadcast a signal to the environment. They blink at different intervals with beacon rates ranging from a few milliseconds to several hours. They have battery lifetimes of up to several years. To such extent they need neither the energy supply from the reader (section 3.1) nor do they broadcast by coupling (section 3.2). The active tags in the wide sense as listed in Table 3 have an independent energy supply and transmitter for broadcasting.

6 Discussion

Following the technical and legal outlines this section discusses the arguments supporting the claim why marketing SRD as (active) RFID tags might backfire on the RFID industry. It also sheds light why this strategy is unlikely to backfire on the SRD industry.

6.1 Backfire on the RFID Industry

Neither Dalal [5] nor various other legal authors accurately differentiate the types of RFID tags. It is argued in this paper that it will make a difference in the outcome of a court decision and in policy making whether the surveillance is with a passive RFID tag, an active RFID tag, or with a short-range transmitter. By the definitions used in this analysis (details especially in section 3.1), the radio transmitting device used in *United States v. Knotts* [30] is a short-range transmitter, not an RFID. To such extent the findings of SRD should not be and as argued herein are not applicable to active RFID in the narrow sense (see Section 3).

People carrying RFID tags will generally fall within the protection of the Fourth Amendment as the Fourth Amendment protects people, not places. [15] RFID tags in the narrow sense as understood and advocated in this paper need power from the reader to transmit the information back to the reader. Whereas people in public will generally expect other people to see where they go [30], it must remain a persons right of privacy (not) to disseminate information generally

contained in an RFID tag, i.e., information that is not generally accessible by other people. As both passive and active RFID tags in the narrow sense need the energy of a reader to transmit data back to the reader, broadcasting the data is not possible without an antecedent manipulation by the reader. By contrast SRDs continually and indiscriminately transmit information contained in them in intervals to the environment. In the case of a SRD the person (deliberately) carrying the SRD will expect the environment to pick up the transmitted data and “searching” such data will thus not be unconstitutional under the Fourth Amendment.

On the one hand, eleven tag manufacturers and suppliers are marketing their short-range transmitters as active RFID tags. The tags of these suppliers do not transduce the radio frequency of the reader. They have their own energy supply for broadcasting and have a transmitter to broadcast a signal in intervals indiscriminately to the environment. On the other hand, the legal community does not differentiate accurately between the different tag functionalities. If at all, it relies on Glover’s understanding of functionality for passive, semi-passive/semi-active and active tags. This means that the legal community includes the self dynamic functionalities of short-range transmitters in their understanding and analysis of RFID. The legal analysis should differentiate between the tag functionalities but it does not. Here it is argued that legally it makes a difference if the tag needs the reader’s radio frequency for energy supply and broadcasting, or not.

In line with this argumentation the claim can be made that if the RFID industry keeps marketing their short-range transmitters as RFID, the legal community might continue including such broad and self dynamic device functionalities in its legal interpretation and analysis of RFID. The inclusion of broad SRD functionalities by the legal community in their interpretation, policy and decision making might lead to restrictive interpretation, use and limited legal acceptance of RFID. Why? Because if monitoring a beeper that broadcasts its signals in public is not unconstitutional under the Fourth Amendment and the legal community perceives SRD and RFID to be the same technology due to the marketing endeavours of the industry, then the privacy advocates might join forces to legally stop the implementation and deployment of RFID in order not to run the risk of having

constitutional surveillance of RFID tags in the narrow sense without a warrant. Hence, the marketing strategy of riding on the trend wave of RFID might backfire on the RFID industry as the industry will need to follow (more) restrictive law and case decisions. The result might be restrictive implementation and deployment possibilities and therefore limited device and service sales.

6.2 Backfire on the SRD Industry?

Why should the lack of differentiation between RFID and SRD be a problem for the RFID industry and not for the SRD industry? Could the SRD industry not also suffer from the joint marketing of both technologies as RFID? Could marketing SRD as active RFID backfire on the SRD industry?

It has been argued that reading an (active) RFID in the narrow sense is more intrusive as compared to an SRD because it requires an antecedent manipulation by the reader to trigger the data broadcast. Consequently it could be argued that marketing SRD as RFID will have negative effect on the SRD industry (and not the other way around as stated in the previous section) because the more restrictive legal interpretation of RFID in the narrow sense could spill over to SRD and make the surveillance of SRD broadcasts unconstitutional without a warrant.

The following arguments disapprove such assumption: SRD is being marketed as RFID, not vice versa. Section 5.2 lists short-range transmitters that are promoted as active RFID. The indiscriminate broadcasting of SRD merges into the RFID technology in the narrow sense, not vice versa. RFID is in focus, SRD is out of perception. What remains is the notion that short-range transmitters are active RFID tags.

From a legal perspective the analysis in section 4.2 reveals that the majority of authors in the investigated legal articles use Glover's and not, e.g., Finkenzeller's understanding of active RFID tags (in the narrow sense). Hence, they perceive the technology exactly as it has been promoted by the industry. So the legal community transposes the constitutional surveillance of a beeper as ruled in *United States v. Knotts* [30] into the RFID field and not vice versa.

For these reasons it is not anticipated that marketing SRD as active RFID will backfire on the SRD industry.

7 Conclusion

As has been consistently argued in this paper, marketing SRD as active RFID might backfire on the RFID industry. This leads to the following two conclusions:

1. The industry needs to clarify its terminology for SRD and RFID. The term SRD seems deceptive anyhow since it infers that the range is even shorter than with RFID (whereas in reality it is much longer). Furthermore the current marketing strategy of marketing SRD as active RFID (section 5.2) might need to be reconsidered.
2. The legal community needs to better differentiate both RFID and SRD technology. In order accurately analyse the technical and make distinguished legal recommendations and regulations the legal community must better understand the underlying technology.

References

1. Asamoah, A. K.: Not as easy as it may appear: Using radio frequency identification technology to fulfill the prescription drug marketing act's elusive pedigree requirement. *Food and Drug Law Journal*, 61, 385 (2006).
2. Bensky, A. (ed.): *Shortrange wireless communication* (2nd edition). Elsevier, Amsterdam (2004).
3. Brito, J.: Relax don't do it: Why RFID privacy concerns are exaggerated and legislation is premature. *UCLA Journal of Law and Technology*, 5 (2004).
4. *Cardwell v. Lewis*, 417 U.S. 583 (1974).
5. Dalal, R. S.: Chipping away at the constitution: The increasing use of RFID chips could lead to an erosion of privacy rights. *Boston University Law Review*, 86, 485 (2006).

6. Delaney, K.: RFID: Privacy year in review: America's privacy laws fall short with RFID regulation. *A Journal of Law and Policy for the Information Society*, 1, 543 (2005).
7. Eden, J. M.: When big brother privatizes: Commercial surveillance, the privacy act of 1974, and the future of RFID. *Duke Law & Technology Review*, 20 (2005).
8. Eleftheriou, D., Berliri, M. & Coraggio, G.: Data protection and E-commerce in the United States and the European Union. *International Lawyer*, 40, 393 (2006).
9. Eng, G.: Technology trends affecting the practice of law. *Los Angeles Lawyer*, 28-APR, 79 (2005).
10. Eschet, G.: FIPS and PETS for RFID: Protecting privacy in the web of radio. *Jurimetrics Journal*, 45, 301 (2005).
11. Finkenzeller, K.: RFID Handbuch (4. Auflage). Hanser, München (2006).
12. Glover, B. & Bhatt, H.: RFID essentials (1st edition ed.). O'Reilly, Beijing (2006).
13. Handler, D.: The wild, wild west: A privacy showdown on the radio frequency identification (RFID) systems technological frontier. *Western State University Law Review*, 32, 199 (2005).
14. Herbert, W. A.: No direction home: Will the law keep pace with human tracking technology to protect individual privacy and stop geoslavery? *A Journal of Law and Policy for the Information Society*, 2, 409 (2006).
15. *Katz v. United States*, 389 U.S. 347 (1967).
16. Kern, C.: Anwendung von RFID-Systemen. Springer, Berlin (2006).
17. Kobelev, O.: Big brother on a tiny chip: Ushering in the age of global surveillance through the use of radio frequency identification technology and the need for legislative response. *North Carolina Journal of Law & Technology*, 6, 325 (2005).
18. Koops, B. & Leenes, R.: 'Code' and the slow erosion of privacy. *Michigan Telecommunications and Technology Law Review*, 12, 115 (2005).
19. *Kyllo v. Unites States*, 533 U.S. 29 (2001).

20. Landau, S.: Digital age communications law reform: National security on the line. *Journal on Telecommunications & High Technology Law*, 4, 409 (2006).
21. U.S. National Prohibition Act, ch. 85, 41 Stat. 305 (1919).
22. *Olmstead v. United States*, 277 U.S. 438 (1928).
23. Smith, S. L.: Symposium review: RFID and other embedded technologies: Who owns the data? *Santa Clara Computer and High Technology Law Journal*, 22, 695 (2006).
24. Smith, S. L.: Gone in a blink: The overlooked privacy problems caused by contactless payment systems. *Marquette Intellectual Property Law Review*, 11, 213 (2007).
25. Stark, S. C., Nagle, E. P.: Full speed ahead with DOD identification requirements: Next stop, radio frequency identification. *Procurement Lawyer*, 40-Fall, 11 (2004).
26. Stein, S. G.: Where will consumers find privacy protection from RFID?: A case for federal legislation. *Duke Law & Technology Review*, 2007, 3 (2007).
27. Terry, N. P.: Assessing the technical, conceptual, and legal frameworks for patient safety information. *Widener Law Review*, 12, 133 (2005).
28. Thompson, D., Kot, K., Brothers, J.: Radio frequency identification: Legal aspects. *Richmond Journal of Law and Technology*, 12, 6 (2005).
29. U.S. Const. Amend. IV.
30. *United States v. Knotts*, 460 U.S. 276 (1983).
31. Willingham, K. M.: Scanning legislative efforts: Current RFID legislation suffers from misguided fears. *North Carolina Banking Institute*, 11, 313 (2007).
32. AAiD: URL
<http://www.autoaccessid.com/Files/File/Cutsheets/AA-T800.pdf>
(last visited December 9, 2007).
33. AeroScout: URL
<http://www.aeroscout.com/data/uploads/AeroScout%20T3%20T ag%20Data%20Sheet.pdf> (last visited December 9, 2007).

34. Axxess: URL
<http://www.axcessinc.com/products/docs/containertag.pdf> (last visited December 9, 2007).
35. Multispectral: URL
http://www.multispectral.com/pdf/Sapphire_VISION.pdf (last visited December 9, 2007).
36. RF Code: URL
http://www.rfcode.com/images/media_kit_docs/m100_tech_spec_sheet.pdf (last visited December 9, 2007).
37. RFID Inc.: URL <http://www.rfidinc.com/products1.html> (last visited December 9, 2007).
38. RFind: URL
http://www.rfind.com/pdf/RFind%20Tags%20Gateway%20_V1.5_%2005-01-07.pdf (last visited December 9, 2007).
39. Savi: URL http://www.savi.com/products/SaviTag_656.pdf (last visited December 9, 2007).
40. Synometrix: URL
http://www.synometrix.com/SYNOMETRIX_SMPTK-002_active_RFID_tag_specification.pdf (last visited December 9, 2007).
41. Ubisense: URL
<http://www.ubisense.net/media/pdf/Ubisense%20Compact%20Tag%20EN%20V1.0.pdf> (last visited December 9, 2007).
42. Wherenet: URL
<http://www.wherenet.com/pdf/products/WhereTagIII.6.14.07.pdf> (last visited December 9, 2007).
43. EPCglobal Inc., Glossary: URL
<http://www.epcglobalinc.org/what/cookbook/chapter5/039--GlossaryV.6.0May2005FINAL.pdf> (last visited December 9, 2007).
44. RFID Journal: URL <http://www.rfidjournal.com/article/glossary/3> (last visited December 9, 2007).

3. MODALITY MIX ARTICLE

Modality Mix of RFID Regulation

Daniel Ronzani

Journal of International Commercial Law and Technology
Vol. 3, No. 4, pages 222 - 232

Reprint and publication of author generated version of the article with courtesy of the Journal of International Journal for Commercial Law and Technology (8 October 2009). Copyright with the Journal of International Journal for Commercial Law and Technology.

Changes to format and references.

Please see Part One of this thesis for distinction between the term (social) norm used in Part One of this thesis and in the following article.

Modality Mix of RFID Regulation

Daniel Ronzani

CBS, Centre for Applied ICT, Howitzvej 60, 2000 Frederiksberg,
Denmark,
dr.inf@cbs.dk

and

IBM Research GmbH, Säumerstrasse 4, 8803 Rüschlikon,
Switzerland, dan@zurich.ibm.com

Abstract

This paper provides a general reflection on how law must manage the evolution of technology. By the example of radio frequency identification (RFID) it analyses the necessity of RFID regulation based on Lessig's four modalities law, norms, market and architecture. This paper suggests that a trade-off between or complementing of the four modalities is necessary for a holistic regulation of RFID. To support this claim various topics of the draft recommendation on the implementation of privacy, data protection and information security principles in RFID applications by the European Commission of February 2008 are cross-examined with and attributed to one of the four modalities. This paper concludes that the draft recommendation does not provide precise supplementing legislation to justify its implementation. Many law-related issues of the draft recommendation can be traded off against or complemented by the other three modalities norms, market and architecture.

1. Introduction

The Internet of Things is a network of communicating devices that can interact in context of the physical world (Buckley, 2006). In this realm radio frequency identification (RFID) is one step “towards ubiquitous computing which together with technology-convergence may lead to seamless integration of the physical world with cyberspace” (Van de Voort, Maarten & Ligtoet, 2006). Because (i) RFID is one of the interfaces to cyberspace and (ii) the European Commission’s Directorate General Research Centre suggested that a closer look at existing legal framework for RFID along with the development of processes for establishing guidelines and best practices is needed (Van Lieshout et al., 2007), it is justified to recall Judge Frank Easterbrook’s speech titled “Cyberspace and the Law of the Horse” (Easterbrook, 1996). In his speech Easterbrook argues that the best way to learn law applicable to specialized endeavours is to study general rules. He strongly criticizes the implementation of a specialized law for new technologies:

“We are at risk of multidisciplinary dilettantism, or, as one of my mentors called it, the cross-sterilization of ideas. Put together two fields about which you know little and get the worst of both worlds. [...] Beliefs lawyers hold about computers, and predictions they make about new technology, are highly likely to be false. This should make us hesitate to prescribe legal adaptations for cyberspace. The blind are not good trailblazers.” (Easterbrook, 1996)

One of Easterbrook’s arguments is that if legislators are too far behind in matching law to well-understood technology such as photocopiers (copyright), then what chance will one have for fast living computer technology? In his opinion it makes no sense to match an imperfect legal system to an evolving world that is understood poorly. His advice is – in a nutshell – to stick to existing laws (Easterbrook, 1996).

Lessig (1999) disagrees with Easterbrook and argues that interdisciplinary thinking is important. He offers techniques for

escaping the limits of a regulator by “recognizing the collection of tools that a society has at hand for affecting constraints upon behavior” (Lessig, 1999). According to Lessig, the tools are: law, norms, market and architecture. Many authors suggest regulating RFID with a multispectral approach that includes, for instance, changes in law, furthering of guidance and self-regulation, implementation of technical measures or improvement of education (Van de Voort, Maarten & Ligtvoet, 2006; Hustinx, 2007; Hübner-Fischer, 2000). However, to date there seems to be little effort to move away from enacting new laws towards embracing the other three regulatory tools envisioned by Lessig. Hence, the claim in this paper is that the regulation already enacted in Europe suffices and that the focus needs to shift towards norms, market and architecture. There is no need for additional legal regulation such as the draft recommendation on the implementation of privacy, data protection and information security principles in applications supported by RFID in February 2008 (hereinafter “Draft Recommendation”).

The debate on the applicability of Lessig’s four tools concerns many new fields, in which a new technology is prevalent. The dispute is not RFID technology specific. However, RFID is a good proxy to discuss this debate since it is very topical. This discussion is organized as follows: Section 2 structures the problem as to why a mix of modalities is necessary. Section 3 offers an overview of the four modalities. In section 4, the key topics of the Draft Recommendation are first analysed and then supplemented with tentative solutions. Section 5 concludes that the Draft Recommendation by the European Commission should not be implemented because it is redundant with enacted legislation. Instead, a trade-off in favour of the modalities is proposed.

2. Problem Statement

In 2006 the European Commission conducted several workshops and a public consultation process on RFID (ICS, 2007). The European Commission noted that despite most stakeholders still being unaware of the potential and risk of RFID, opposing camps had already formed. The scope of the 2006 consultation process was to advance the debate on RFID objectively and to provide a balanced overview of the

necessary action on RFID issues (Van de Voort, Maarten & Ligvoet, 2006). In general, the survey showed that two-thirds of the 2190 respondents of the 2006 RFID consultation feel that the current legislation is inadequate and that existing laws should be modified in order to strengthen the protection of personal data and privacy. Specifically on security and privacy issues more than half of the respondents report that some kind of legislation regulating RFID should be considered (___, 2006; COM (2007) 96).

Lessig states that law alone can neither enable nor guarantee legal values. He therefore proposes four modalities of regulation (Lessig, 1999): law, norms, markets and architecture. He notes that these modalities regulate together and that, depending on the context to be regulated, there is a trade-off between them. Thereby a modality can influence either an individual directly or another modality that subsequently influences the individual. The goal is to find the optimal mix which depends on the plasticity of these four different modalities (Lessig, 1999).

The problem is not that Lessig's modality mix is not used today. As Table 1 shows Lessig's concept is used, albeit with different terminology. The problem is that from a holistic perspective we risk over-regulating with law if we do not consider the trade-off between the four modalities. As noted earlier, the claim in this paper is that if norms, market and architecture are considered, this will result in less need for laws. This trade-off is possible and affordable because the technology-independent legislation enacted at European level is already sufficient to protect the stakeholders (with some limitations).

	Lessig (1999)	Hübner-Fischer (2000)	Reding (2006)
Modalities	Law	Law	European rules
	Norm	Fair information practices (FIP)	Self-regulation
	Market	–	Industry
	Architecture	Privacy enhancing technology (PET)	Privacy enhancing technology (PET)

Table 1: Different terminology for the same modalities of RFID regulation.

Following the first public consultation on RFID held in 2006 the European Commission issued the Draft Recommendation. In this paper the Draft Recommendation will be analysed based on Lessig's modality mix. The next section outlines the four modalities in more detail.

3. Modalities

The four modalities law, norms, market and architecture of Lessig's concept of behavioural constraints regulate together and the net regulation of any policy is the sum of the regulatory effects of the four modalities (Lessig, 1999). It is important to distinguish between the four modalities.

Law typically regulates behaviour by statutes. Law is regulated, controlled and enforced by government authorities. Mostly there will be a constitutional mandate to enact statutes. The statutes can envision further delegation to ordinances or regulations. The European Commission, for example, has enacted directives that need to be implemented into national law of EU member states. The protection of personal data, for instance, is covered by the technology-independent Directive 95/46/EC regardless of the means of procedures used for data processing (COM (2007) 96). But there are also less enforceable regulations, such as the Draft Recommendation.

Norms regulate similarly as but not equal to law (Lessig, 1999). Norms are non-legal rules that certain individuals feel compelled to follow despite the lack of formal legal sanctions. Or put positively, they are non-legal rules that certain individuals follow because they benefit from doing so (Carlson, 2001). Both modalities, law and norms, threaten punishment *ex post*. But whereas the regulation of law is centralised at authority level, the regulation by norms is decentralised by and to a community (Lessig, 1999). The sanction to be imposed by the community can be extended to third parties. Thereby codes of conduct are created by imposing requirements on an entire community rather than merely on the interested (private) parties (Bendor & Swistak, 2001). EPCglobal, the leading standardization body for the development of industry-driven standards for the electronic product code to support the use of RFID, for instance, has

issued guidelines on RFID. These are regulations that are followed and sanctioned as norms by the members of EPCglobal.

Market regulates behaviour by different influences, such as demand and supply that is reflected in price. Prices can constrain access. Lower RFID tag costs and improved RFID tag performance have opened new markets and applications for RFID (Van de Voort, Maarten & Ligtoet, 2006). Industrial entities, for instance, are bringing RFID to market and many small- and medium-sized entities have successfully deployed RFID (COM (2007) 96). However, mass implementation is price-driven and it is generally assumed that a cost reduction of passive RFID tags to less than 1 cent is necessary for a large scale adoption (COM (2007) 96).

Architecture – understood by Lessig as the physical world as we find it – also regulates in the form of shaping one's behaviour. In this paper it is argued that RFID architecture is divided into physics and systems (artefacts). On the one hand, RFID architecture has specific characteristics imposed by the physics of radio waves that direct and limit the way RFID technology can be implemented and used. For instance, the characteristic that water absorbs, metal reflects and other materials have varying effects on radio waves of passive tags (Sood, 2007). On the other hand, RFID architecture includes the structure of IT systems, like a multi-tier RFID system comprising the RFID reader, middleware and the backend enterprise system (Lahiri, 2006).

Each section and topic of the Draft Recommendation can be attributed to one or more of the four modalities. In the following section an analysis and a tentative solution are proposed for each of the most important sections and topics of the Draft Recommendation.

4. Discussion

Only 15% of the respondents of the 2006 public consultation viewed self-regulatory efforts by themselves adequate to regulate RFID (Reding, 2006). By cross-examining all four modalities with the topics of the Draft Recommendation this paper shows that there is a misbalance in the modality mix of RFID regulation. Whereas it could be argued that the Draft Recommendation itself falls entirely within the

modality of law (see Section 3) and therefore cannot be accounted for by the other three modalities, the topics of the Draft Recommendation touch upon all four modalities. The analysis of these topics in the Draft Recommendation is justified in order to propose which legal modalities are best traded off against the other three modalities, i.e., norms, market and architecture.

4.1 Article 1: Scope

4.1.1 Analysis

Article 1 of the Draft Recommendation covers the scope. The Draft Recommendation provides guidance on privacy, data protection and information security to EU member states and stakeholders in a lawful, ethically admissible, as well as socially and politically acceptable way on the design and operation of RFID applications.

The scope of the Draft Recommendation is to provide guidance and therefore by nature is not compulsory. The question arises whether a guidance of this sort will provide the necessary legal certainty for the sale, implementation and deployment of RFID. As has been noted at the 2006 RFID Public Consultation Workshop on Applications and Emerging Trends, adhering to guidelines is voluntary and lacks enforcement options to protect the public from non-compliant companies. Therefore guidelines are likely to prove inadequate to regulate privacy issues (Van de Voort, Maarten & Ligtoet, 2006). The same will apply to security issues.

Although this Draft Recommendation aims at achieving a coherent internal market approach towards information security (article 6(2)), EU member states generally remain free to implement national legislation with or without adapting this Draft Recommendation. It is therefore criticised that the scope of the Draft Recommendation does not support the achievement of a coherent internal market, which is one of its main objectives. The Draft Recommendation lacks the economic evaluation. It covers legal, ethical, societal and political values but not economic ones.

4.1.2 Tentative Solution

The proposal in this paper is twofold. First, the Draft Recommendation, or after its implementation the recommendation itself, cannot be viewed as a norm, regardless of which of the three theories about norm creation one follows – norm internalization by Robert Cooter, esteem worthiness by Richard McAdams, or equal behaviour by Eric Posner (in: Carlson (2001)). The Draft Recommendation is issued by the European Commission as the central authority and will remain a legal, but unenforceable, tool because the EU member states do not need to implement it. In contrast, the ethically admissible as well as socially and politically acceptable ways of use of RFID technology are norms. Violations of such norms can be sanctioned outside of the Draft Recommendation. To the extent the Draft Recommendation by the European Commission remains unenforceable it should not be implemented.

Second, if the Draft Recommendation were to be implemented nonetheless, then its scope would need to be extended to include the economic value of RFID. In order to find solutions that are acceptable to both consumers and the RFID industry the economic aspects of RFID implementation and deployment are important. This means that the economic value will need to be addressed in the scope as well. This would extend the modalities to include the market. Whether RFID still is in its infancy, with most applications not being large-scale, and whether the forecast for economic benefits remain yet unclear (Van Lieshout et al., 2007), or whether RFID is about to become very widely used (Reding, 2006), it is important for Europe to clear away legal issues that may act as barriers to a rapid deployment in RFID and also to implement initiatives that will allow European citizens to benefit from RFID technology. Europe is a leading region in research and development for RFID, and Europe's economy needs to remain strong and competitive (Reding, 2006).

4.2 Article 2: Definitions

4.2.1 Analysis

Article 2 covers the definitions used in the Draft Recommendation. The definitions of “RFID application”, “RFID application operator”,

“RFID tag”, “reader” and “deactivation” are of interest because they are unclear.

The definitions of “RFID application” and “RFID application operator” are imprecise. The former seems to include an entire IT environment irrespective of its relation to RFID technology. The latter is also too broadly defined by stating “[...] person who develops, implements, uses or maintains a[n] RFID application” (emphasis added). That definition seems to include suppliers of RFID technology and services. But the Draft Recommendation also makes a distinction in article 3(3) between the “RFID application operators and providers of such [RFID] applications” (emphasis added) that is not reflected in the aforementioned definition of “RFID application operator”. Hence, the definition of “RFID application operator” remains unclear as to whether the person developing, implementing, using, or maintaining an RFID application is intended to exclude the provider, or not. There are entities in the RFID market that offer a broad range of ICT services. Do these companies also fall within the definition of “RFID application operator”? What if they offer outsourcing services that cover RFID technology: does the definition of “RFID application operator” extend to them as outsourcers as well?

Second, article 2(b) of the Draft Recommendation defines RFID tags as being an RFID device either capable of recoupling, backscattering or reflecting, and modulating a carrier signal received from an RFID reader; or capable of producing a radio signal. The latter function refers to active RFID tags that use the (internal) energy source not only to power the chip but also to emit a signal independent of the influence from an RFID reader. An apparatus with such characteristics is a short-range device according to Finkenzeller (2006), Kern (2006) and Bensky (2004). This transmitter - receiver function contradicts the definition of “reader” in article 2(c) of the Draft Recommendation, which “stimulate[s] and effect[s] a modulated data response from a tag or a group of tags”. Clarification on passive, semi-active (battery-assisted), and active tags is necessary. As has been suggested at the Internet of Things 2008 Conference (IOT 2008), legal implications could be different, depending on whether active tags are understood in a narrow or wider sense (Ronzani, 2008).

Third, the definition of “deactivation” suggests that any functionality of a tag be terminated. Regardless of the definition in the Draft

Recommendation, the term “deactivation” (emphasis added) suggests in the case of a passive tag that the functionalities are active. But this is not the case for passive tags due to its architecture. Passive tags need to be activated by a carrier signal received from an RFID reader to generate the necessary energy to recouple, backscatter or reflect.

4.2.2 Tentative Solution

Definitions that are unenforceable and imprecise are likely to create more confusion than generate a coherent understanding. Only if they were defined in an enforceable law would such terms add value. But as (i) the Draft Recommendation is non-binding and thus unenforceable, and (ii) technology is evolving rapidly, the laws should be technology-independent. A specific legal definition of these terms is therefore unfavourable.

Following Lessig’s modality mix it is more favourable to regulate by market and architecture in this situation. The RFID application needs to be addressed by architecture. It will provide the boundaries of what is technically possible and what is not possible. Who the RFID application operator is can be determined by the market.

In light of the Draft Recommendation focusing on privacy, data protection and information security aspects of RFID technology deployment, the cessation of all functionality is unreasonable and exaggerated. A cessation of the entire functionality of a tag could ultimately lead to a cessation of deployment of RFID technology by the industry. If a deactivation is necessary at all, then it should be limited to certain functionalities only.

4.3 Article 3: Privacy Measures

4.3.1 Analysis

Article 3 of the Draft Recommendation stipulates the privacy and data protection measures to be taken by the RFID application operator. In the following the privacy impact assessment, the burden of proof, and its publication are discussed in more detail.

First, RFID application operators need to conduct a privacy impact assessment prior to the implementation of RFID applications. The Draft Recommendation foresees that its level of detail depends on the

risk associated with the application. Here it is argued that the risk will eventually only be known after the assessment has been performed and that therefore the level of detail cannot be adjusted in a timely manner. The risk lies completely with the RFID application operator. In order not to run retrospectively the risk of not having assessed the threat correctly and thus not having applied a level of detail proportionate to such risk, an RFID application operator would always need to conduct a full scope privacy impact assessment.

Second, the RFID application operator and the component provider need to take the “appropriate technical and organisational measures to mitigate” the risk “where it cannot be excluded that processed data is related to an identifiable natural person” (emphasis added). This exclusion requires negative proof evidence that is almost impossible to produce. It is likely that RFID opponents could frequently argue that processed data can be linked to an identifiable natural person somewhere in the end-to-end dataflow and that such risk could indeed never be excluded. This would render the paragraph useless.

Third, there is an option that the RFID application operator’s privacy impact assessment is made public. Such publication could probably be interpreted under certain national legislations as being a representation and warranty by the issuing entity. To this extent it might exceed the mandatory requirements for representation and warranty of national law. Furthermore it is not clear why the provider of components would be excluded from such publication as stipulated in article 3(3).

4.3.2 Tentative Solution

As Van de Voort, Maarten & Ligtoet (2006) have noted, guidelines are likely to prove inadequate to regulate privacy issues. Hence, for the large part norms will not be a suitable modality. The risk assessment would therefore need to remain regulated by law. However, following the argument of the preceding subsection that the risk assessment timeline is unmanageable, it is suggested here that the risk assessment be omitted altogether as regulatory tool.

Burden of proof is regulated in and a tool of process or procedural law. What proof evidence is necessary and which party needs to provide such evidence or counter-evidence is subject to national procedural

legislation of the individual EU member states. It is suggested in this paper that the burden of proof remain a legal modality of national law. It is not favourable to interfere with such legislation in an unenforceable draft recommendation.

Notwithstanding the foregoing, publication of privacy measures can be regulated by guidelines, i.e. by norms. It seems reasonable that a (RFID) community agrees on how, and what kind of information of implemented, privacy measures should be published.

4.4 Article 4: Codes of Conduct

4.4.1 Analysis

Article 4 of the Draft Recommendation encourages trade or professional associations or organisations involved in the RFID value chain to draw up specific codes of conduct on RFID.

Article 27 of Directive 95/46/EC already stipulates an encouragement for the EU member states to make provisions for trade associations and other bodies. Article 4 of the Draft Recommendation is a partial copy of article 27 of Directive 95/46/EC, which encourages the drawing up of codes of conduct, and thus superfluous. Codes of conduct on RFID partly are already in place, e.g., the public policy guidelines by EPCglobal.

4.4.2 Tentative Solution

It has been suggested by participants of the 2006 RFID consultation workshop that a compromise between strict regulations and voluntary (and typically unenforceable) guidelines might be a possible solution. Companies would agree to high fines if they breached privacy guidelines they have accepted (Van de Voort, Maarten & Ligtoet, 2006). According to Homans (in: Gibbs (1965)) a “statement made by a number of members of a group, not necessarily by all of them, that the members ought to behave in a certain way in certain circumstances” qualifies as a norm. According to Carlson (2001), codes of conduct are created by norms that impose requirements on an entire community and not merely on the interested parties. The obligation to impose a sanction can be extended to third parties, i.e.,

people unaffected by the deviation but in the position of sanctioning the deviant.

The recommendation by the European Commission to extend the legal regulations by including norms is favourable. This expansion is in line with Lessig's modality mix. To this extent the proposal in this paper is to acknowledge that the legal provisions suffice to establish the necessary codes of conduct. The enacted provisions must not be replicated in the unenforceable Draft Recommendation. The focus rather needs to be on actually establishing or strengthening acceptable codes of conduct by (RFID) communities.

4.5 Article 5: Information on RFID Use

4.5.1 Analysis

Article 5 of the Draft Recommendation regulates the use information of RFID. Where RFID applications are implemented in public places, a written comprehensible policy needs to be made available by the RFID application operator, such as the identity of the RFID application operator or the purpose of RFID application.

The value-add of this provision is limited insofar as Directive 95/46/EC already lists an extensive catalogue of information that needs to be provided by the data controller or its representative. This catalogue in article 10 of Directive 95/46/EC is a minimum requirement that includes identity of controller or representative, purpose of processing, and further information. National law can foresee more extensive regulation. In contrast to the Draft Recommendation, national legislation of EU member states is required to implement the provisions of Directive 95/46/EC into national law. To this extent the provision for information in cases of collection of data from a data subject is already set at a more stringent legislative - and not only a recommendatory - level.

4.5.2 Tentative Solution

A legal solution to establish norms is favourable. This shift of regulation by law to regulation by norms is in line with Lessig's modality mix. Similar to the tentative solution in the preceding section, the proposal is to acknowledge that the current legal provisions suffice

to establish the necessary codes of conduct and not to replicate the provision in the Draft Recommendation.

4.6 Article 6: Information Security Risk Management

4.6.1 Analysis

Article 6 of the Draft Recommendation stipulates the necessity of state of the art security management and application-specific guidelines with best available techniques to achieve a coherent internal (i.e., European) market approach.

First, the value add of this provision is unclear insofar as security of processing is already regulated in detail in Directive 95/46/EC. It provides that the “controller must implement appropriate technical and organizational measures to protect personal data against” (article 17) various processes and incidents, including unauthorized disclosure or access. The provision in the Draft Recommendation is favourable but an unbinding and voluntary encouragement as suggested therein seems obsolete because national legislation is already required to establish such measures.

Second, the development of RFID application-specific guidelines and dissemination of best available techniques for such applications that might be exposed to information security threats should be encouraged at a European level to achieve a coherent internal market. Whereas the exchange of best practices generally seems to be a favourable approach, it is argued here that as long as the 27 EU member states are not required to implement the Draft Recommendation its impact for a coherent internal market remains questionable.

4.6.2 Tentative Solution

The three proposals in the Draft Recommendation can be evenly distributed among the three modalities norms, market, and architecture, because Directive 95/46/EC already sets the necessary legal boundary. As outlined in preceding sections of this paper a replication of enacted legislation in the Draft Recommendation is not necessary. It is preferable to focus efforts on the accomplishment of

state-of-the-art information security management, application-specific guidelines, and a coherent internal market approach other than by legal regulations.

Issues of linking data to individual users are not RFID specific. They need to be tackled irrespective of a specific technology. With regard to RFID, they need to be addressed by 'privacy by design' and need to encompass the processes of data collection, data storage and data management (Van de Voort, Maarten & Ligtoet, 2006). The information security management therefore needs to be attributed to the architecture modality. The Article 29 Data Protection Working Party noted that "for many applications, the tag contains only an Id whose [sic] semantics can only be accessed through a complete IT application environment. [... O]nly a small number of RFID tags bear semantic information" (Schaar, 2005). The information is likely to be stored in a backend system. Such a backend enterprise system would typically encompass the complete suite of applications and IT systems of an enterprise (Lahiri, 2006), i.e., application servers and databases. A database management system is software designed to manage the handling of data. It provides independent representation and storage of data from application programs (Ramakrishnan & Gehrke, 2000). It is therefore argued that the security management should take place within this architecture. This would meet the expectation by 70% of the respondents to the online consultation launched by the European Commission in summer 2006 that plead for privacy enhancing technologies to safeguard privacy (COM (2007) 96).

The application-specific guidelines need to be reflected as norms. The RFID application providers and operators will need to set the guidelines. These guidelines to evolve from within the RFID provider and operator community and cannot be forced upon them from the outside, i.e., through the Draft Recommendation.

4.7 Article 7: RFID Use in Retail Applications

4.7.1 Analysis

Article 7 of the Draft Recommendation is a special clause for retailers. It proposes indication of RFID technology by requiring a sign. It includes the necessity of a legitimate aftersale purpose, and it

foresees an opt-in for consumers at point of sale as well as an opt-out clause. Moreover, deactivation of the tag may not be linked to legal disadvantages.

First, retailers should adopt a harmonised sign to indicate the presence of RFID tags. This seems to be a reasonable proposition that will support the acceptance by the general public. Whether such a sign would need to be on every item, or a centralized notification by the retailer, has yet to be seen. But considering that a product can be sold after the initial purchase, it will probably be favourable to include a sign on the product itself (where possible) or on the packaging that could, however, also be thrown away.

Second, consumers should be informed about a legitimate aftersale purpose. Article 7 of Directive 95/46/EC already stipulates the cases of legitimacy. Three of the six examples enumerated (lit. a, b and f) could apply in RFID retail: (lit. a) the data subject has unambiguously given his or her consent; or (lit. b) processing is necessary for the performance of a contract to which the data subject is party; or (lit. f) processing is necessary for the purposes of the legitimate interests pursued by the controller (except where fundamental rights are violated). Furthermore, the Draft Recommendation text and the introductory remarks to section 3(a) suggest that the only way of making data processing legitimate is by deactivating the RFID tag at point of sale unless the consumer chooses to keep the tag operational (opt-in). This interpretation of Directive 95/46/EC is challenged. According to article 14 of Directive 95/46/EC, the data subject has the right to object at any time to the data processing, especially if data is processed for the purposes of direct marketing. Hence, an opt-out possibility cannot a priori be excluded.

Third, the opt-in clause means that the retailer must by default deactivate the RFID tag at point of sale “where a[n] RFID application processes personal data, or the privacy impact assessment [...] shows significant likelihood of personal data being generated from the use of the application” (Commission of the European Communities, 2008, Art. 7 para. 3(a)) unless the consumer explicitly requests the tagged item to remain “activated” (but see argument in section 4.2.1). As noted above in section 4.2, the definition of “RFID application” is very broad. It includes all IT systems attached to an RFID system. The opt-in clause stipulates the deactivation by default for all tagged retail

items, even if the processing and generation of personal data occur through a back-end database and are managed by a database management system (Van de Voort, Maarten & Ligtoet, 2006). However, here it is claimed that at retail level RFID is a mere input technology. This means that a large part of the issues with data protection and privacy occur at application level, in particular in back-end databases (European Commission, 2006). It can be referred to section 4.6.2 where the information security risk management for database management systems has been discussed.

4.7.2 Tentative Solution

A technology-specific privacy concern that has been identified with RFID is that people may be unaware that they are carrying an RFID tag, which can be read from a distance. Distant reading would apparently enable individualised identification and revealing of personal data (Van de Voort, Maarten & Ligtoet, 2006).

First, the obligation of placing a sign on a product or on the packaging could remain a law modality if this obligation were formulated in a technology-independent way. If the obligation is RFID-specific, then a regulation by norm is more favourable. A guideline within the (RFID) community could regulate such obligation. It is suggested that if a retailer failed to adhere to a guideline it has previously adopted then the consumers would quickly sanction such misconduct by either boycotting the product or even the retailer itself owing to mistrust in such retailer.

Second, two-thirds of all respondents of the 2006 public consultation by the European Commission view the development of technical solutions allowing RFID tags to be disabled as a way to eliminate or greatly reduce the concerns of security and privacy of RFID applications (____, 2006). Nevertheless, here it is argued that the same modality and argument as discussed above for the placing of a sign alerting to the use of RFID technology could apply for the deactivation requirement (as compared to the deactivation itself in section 4.2): the requirement to deactivate can be regulated by a guideline, a norm. Should a retailer fail to adhere to a norm it previously accepted, then the consumers would most probably sanction such (mis-) behaviour with direct consequences for the retailer. However, it must be

emphasized again that, for instance, in retail, (passive) RFID tags are likely to contain only a product code. This would make a person identifiable, but only if the eavesdropper has access to the (backend) database where the data of the customer is stored. The point here is that in retail neither a barcoded nor an RFID-tagged item is likely to directly include personal data of the consumer (Schaar, 2005). In either case the item will only carry a product code (UPC or EPC in this example). Here it is argued that if the personal data is not stored directly on an RFID tag and therefore not directly accessible, then a differentiation between barcoded and RFID-tagged items, and therefore a deactivation of the RFID tag at point of sale as compared to barcodes not being removed at point of sale, is unjustified; even if barcodes require line of sight for the read and RFID tags do not. Only where personal data is stored directly on the tag should – if there are no security measures in place such as encryption – a deactivation or removal be considered.

Participants of the 2006 RFID consultation claimed that databases may not be secure enough and that criminals might illegally use data collected in such databases (Van de Voort, Maarten & Ligtvoet, 2006). Following the general principle of criminal law “*nulla poena sine lege*”, the terms criminal and illegal use imply that a law is being breached. Why then enact yet another law if the laws already sanction illegal use? Remedies and sanctions for breach of the law are regulated at national EU Member State level, for instance, in Directive 96/9/EC and national criminal law.

Finally, the necessity of a legitimate aftersale service is likely to be regulated by the market. If the suppliers of goods and retailers offer additional services (free of or at charge) and the demand for such services increases, this could be a legitimate argument for promoting aftersale services.

4.8 Article 8: Awareness Raising Actions

4.8.1 Analysis

Article 8 of the Draft Recommendation addresses RFID awareness.

Although the explanation to article 8 of the Draft Recommendation suggests that both, general public and enterprises, especially small

and medium enterprises, be informed about the benefits and risks of RFID technology, the text of the Draft Recommendation only mentions “companies, in particular SMEs”. It is unclear why governments, administrations and especially the general public are omitted from the enumeration in the Draft Recommendation. Administrations are large user groups of RFID technologies, such as the US Department of Defence, and the use of RFID technology is likely to increase in the public sector.

4.8.2 Tentative Solution

Two-thirds of all respondents of the 2006 public consultation view the development of awareness raising campaigns to educate consumers as way to eliminate or greatly reduce the concerns of security and privacy of RFID applications (___, 2006). The efforts to increase the awareness of the government and the general public need to improve greatly. It is therefore necessary that governments and administrations adhere to the same principles as the industry. Furthermore, the general public needs to be informed and educated on RFID technology, threats and risks. Consumers are mature and, with sufficient awareness-raising, quite capable of making their own informed decisions.

5. Conclusion

In the RFID space, polarizing solutions are generally not favourable. A balance must be found in many cases. For instance, if RFID were to be legislated to the last detail, the following two extreme scenarios could be envisioned: (i) Law is (entirely) in favour of the consumer. In order to fulfill the legal requirements, the RFID industry would need to invest disproportionately to meet the requirements of the law. This would lead to an uneconomic business case and subsequently to the RFID industry reducing or even ceasing its investments in RFID. The RFID market would collapse. (ii) Law is (entirely) in favour of the RFID industry. The RFID industry would invest in RFID, and the RFID market would initially grow. But consumers, to whose disfavour the enacted legislation would be, would counter-react by boycotting the market. Sales would shrink. The RFID market would also collapse.

Table 2 shows a possible matrix for the topics regulated in the Draft Recommendation. A full square “■” indicates where the topic is currently attributed in the Draft Recommendation. A circle “○” shows where the topic might be more effectively used in other modalities. A dash “-” indicates a topic that is either not addressed or should not be addressed in the Draft Recommendation.

Draft Recommendation by European Commission		Modalities			
Sections in Draft Recommendation	Selection of topics in Draft Recommendation	Law	Norms	Market	Architecture
Scope	Law	■ ○			
	Ethics	■	○		
	Society and Politics	■	○		
	Economy	-		○	
Definitions	RFID application	■			○
	RFID application operator	■		○	
	Tag	■			○
	Reader	■			○
	Deactivation	■			○
Privacy Measures	Risk assessment	■ -			
	Burden of proof	■ ○			
	Publication	■	○		
Code of Conduct	Specific codes of conduct	■	○		
Information on RFID Use	Public places	■	○		
Inform. Security Risk Management	State-of-the-art information security management	■			○
	Application specific guidelines	■	○		
	Coherent internal market approach	■		○	
Retail	Signs	■	○		
	Legitimate after-sale	■		○	
	Opt-in / opt-out	■	○		
	Deactivation requirement	■	○		
Awareness raising	Companies and SMEs	■	○		
	Government and general public	-	○		
	Good practices in RFID application implementation	■	○		

Table 2: Matrix of Draft Recommendation with Lessig's Modalities.

Whereas research on the understanding of RFID technology by legal experts has shown that the understanding of RFID technology by legal experts is indeed not always beyond doubt (Ronzani, 2008), generally arguing for multidisciplinary dilettantism is exaggerated. A differentiated approach seems justified. In the past twelve years since Easterbrook's critique on interdisciplinary law and technology much progress has been made in these two fields. But this progress does not necessarily mean that a new law needs to be enacted for every new technology. As has been shown in this paper, general rules of technology-independent legislation suffice to regulate and protect the users and stakeholders of RFID systems.

The various legal recommendations proposed do not provide precise supplementing legislation as suggested by Easterbrook (1996). Technology-independent regulations should not be complicated and diluted by recommendations that address the same issues. There are no additional benefits in the Draft Recommendation for RFID users and stakeholders as compared to the already existing, aforementioned directives. The recommendations are largely redundant with existing mandatory legislation. Issuance of yet another recommendation would be over-regulating and is not to be favoured.

Instead, as has been suggested in the discussion of this paper, the topics of the Draft Recommendation are likely to be more effective if shifted towards one of the other three modalities. Table 2 summarises the discussion of this paper. The topics of the Draft Recommendation are listed in the vertical; the modalities are listed in the horizontal. The Draft Recommendation itself is a law modality. Hence, all the square boxes (■) are in the law column. As discussed in this paper, the topics of the sections in the Draft Recommendation provide trade-off possibilities. Table 2 shows that an extension to the other three modalities of regulation as outlined in this paper has proven appropriate. The shift is indicated in the columns of norms, market and architecture with a circle (○).

The conclusion is that net regulation (Lessig, 1999) and trade-off are not only necessary in the RFID space, but are encouraged. It is viable to reduce the legal regulation by not implementing the Draft Recommendation. The topics of the Draft Recommendation can largely be re-distributed to the other three modalities of norms, market and architecture. Table 2 suggests that following the topics of the

Draft Recommendation will take more regulation by norms than market or architecture to effectively regulate RFID. But that in any case a modality mix is necessary for RFID regulation.

References

1. _____. (2006). The RFID Revolution: Your Voice on the Challenge, Opportunities and Threats. Online Public Consultation - Preliminary Overview of the Results.
2. COM (2007) 96. Communication from the Commission to the European Parliament, the Council, the European Economic and Social Committee and the Committee of the Regions. Radio Frequency Identification (RFID) in Europe: Steps towards a policy framework. COM (2007) 96 final.
3. Bendor, J. & Swistak, P. (2001). The Evolution of Norms. *The American Journal of Sociology*, 106(6), 1493.
4. Bensky, A. (Ed.). (2004). *Shortrange Wireless Communication* (2nd edition). Amsterdam: Elsevier.
5. Buckley, J. (2006). From RFID to the Internet of Things - Pervasive Networked Systems (Conference Organised by DG Information Society and Media, Networks and Communication Technologies Directorate No. Final Report). Brussels, Belgium.
6. Carlson, A. E. (2001). Recycling Norms. *California Law Review*, 89(5), 1231.
7. Draft Recommendation on the Implementation of Privacy, Data Protection and Information Security Principles in Applications Supported by Radio Frequency Identification (RFID): Your Opinion Matters, (2008).
8. Directive 95/46/EC of the European Parliament and of the Council of 24 October 1995 on the Protection of Individuals with Regard to the Processing of Personal Data and on the Free Movement of such Data, (1995).
9. EC, Directive 96/9/EC of the European Parliament and of the Council of 11 March 1996 on the Legal Protection of Databases, O.J. L. 77/20 U.S.C. (1996).

10. Easterbrook, F. H. (1996). Cyberspace and the Law of the Horse. *The University of Chicago Legal Forum*, 207.
11. European Commission (2006). Your Voice on RFID. Background Document for Public Consultation on Radio Frequency Identification (RFID).
12. Finkenzeller, K. (2006). *RFID Handbuch* (4. ed.). München: Hanser.
13. Gibbs, J. P. (1965). Norms: The Problem of Definition and Classification. *The American Journal of Sociology*, 70(5), 586.
14. Hübner-Fischer, S. (2000). Privacy and Security at Risk in the Global Information Society. In D. Thomas & B. D. Loader (Eds.), *Cybercrime: Security and Surveillance in the Information Age* (pp. 173-192). London: Routledge.
15. Hustinx, P. (2007). Opinion of the European Data Protection Supervisor on the Communication from the Commission to the European Parliament, the Council, the European Economic and Social Committee and the Committee of the Regions on Radio Frequency Identification (RFID) in Europe: Steps towards a Policy Framework. COM (2007) 96. Brussels. Belgium.
16. IOT (2008). International Conference for Industry and Academia 2008. <http://www.iot2008.org> (last accessed 1. June 2008).
17. ISC (2007). Information Society Consultations (17. January 2007). http://ec.europa.eu/information_society/tl/activities/consultations/index_en.htm#open_consultations (last accessed 1. June 2008).
18. Kern, C. (2006). *Anwendung von RFID-Systemen*. Berlin: Springer.
19. Lahiri, S. (2006). *RFID Sourcebook*. Upper Saddle River, New Jersey: IBM Press.
20. Lessig, L. (1999). The Law of the Horse: What Cyberlaw Might Teach. *Harvard Law Review*, 113, 501.
21. Ramakrishnan, R. & Gehrke, J. (2000). *Database Management Systems* (2nd ed.). Boston, M.A.: McGraw Hill.
22. Reding, V. (2006). RFID: Why we Need a European Policy. SPEECH/06/597. Brussels, Belgium.

23. Ronzani, D. (2008). *Why Marketing Short-Range Devices as Active Radio Frequency Identifiers Might Backfire*. *The Internet of Things*, Zurich. LNCS 4952, 214.
24. Schaar, P. (2005). *Working Document on Data Protections Issues Related to RFID Technology*. 10107/05/EN WP 105. Brussels, Belgium.
25. Sood, P. (2007). *The Physics Behind RFID*. Unpublished manuscript at http://www.rfidjournalevents.com/liveeurope2007/pdfs/Nov6_University_13-15_physicsBehindRFID.pdf (last accessed 4. June 2008 - restricted website).
26. Van de Voort, Maarten & Ligtvoet, A. (2006). *Towards an RFID Policy for Europe*. Prepared for the European Commission, Directorate General Information Society and Media. DRR-4046-EC.
27. Van Lieshout, M., et al. (2007). *RFID Technologies: Emerging Issues, Challenges and Policy Options, Executive summary*. EUR 22770 EN.

4. SURVEY ARTICLE

Legal Regulation and Consumer: The RFID Industry's Perspective

Daniel Ronzani

Variation of this article to be submitted mid November 2009
for review as book chapter.

Legal Regulation and Consumer: The RFID Industry's Perspective

Daniel Ronzani
CBS, Centre for Applied ICT,
Howitzvej 60, 2000 Frederiksberg, Denmark,
dr.inf@cbs.dk

Abstract

Many journal articles research the diffusion of Radio Frequency Identification (RFID) from a *regulatory* or *consumer* perspective. This research takes a reverse viewpoint and looks at the diffusion of RFID related to regulation by law and the consumer from an industry perspective.

First, interviews with RFID industry stakeholders are conducted. Second, data on RFID is collected in a worldwide online survey with companies and organisations diffusing and adopting RFID technology. Third, empirical data is evaluated by different territories and industries to answer four hypotheses about legal regulation and consumers.

This article recommends that the RFID industry engage in better constructive dialogue with the legal regulator, strengthen its knowledge on applicable legislation, and re-evaluate its information policy to the consumer.

Keywords

RFID, industry, consumer, regulation, diffusion of innovation.

1. Introduction

In the past few years there have been various scholarly articles presenting empirical data on Radio Frequency Identification (RFID), for instance: a survey of librarians in the USA to research the public perception of RFID technology (Strickland and Hunt, 2005). That survey shows, *inter alia*, that even among highly educated members of the public there is more fear than knowledge of information collecting technologies; or the European Commission's survey on RFID titled "The RFID Revolution: Your voice on the Challenges, Opportunities and Threats" (Commission of the European Communities 2006). That survey is a public consultation with the key finding that there is insufficient information available to make an informed analysis of RFID technologies; or an empirical study of anticipated consumer response to RFID presented in Canada (Angeles, 2007). That study evaluates the consumers' willingness to purchase RFID-tagged products; or consumer reactions to RFID-based information systems (IS) in retail in Germany (Rothensee and Spiekermann, 2008). That research shows that people are moderately privacy aware and that their privacy awareness is negatively related to their acceptance of the service.

It is claimed here that researching primarily the view by legal experts or consumers makes the debate encompassing RFID technology quite lob-sided. The point is that if there should be a balance between regulation by law, consumers, and industry in the adoption and diffusion of RFID technology (Kelly and Erickson, 2005), then the industry's opinion must be considered as well. The RFID industry's view on regulation and its perception of consumer awareness is necessary for an economically, legally, and ethically acceptable account of RFID. This article intends to start levelling the misbalance in the research focus by evaluating the RFID industry's perspective in individual interviews and in a worldwide online survey. The purpose of this research is to show the RFID industry's perspective of selected regulatory- and consumer-oriented issues with RFID, and to reveal the shortcomings with the current perspective.

This research is executed in three phases. In the *first phase* individual in-person telephone interviews with three RFID experts from internationally operating companies and organisations are conducted. These interviews serve as exploratory tool and survey question

testing. In a *second phase* a survey is submitted to a list-based population of international companies and organisations engaged in the diffusion and/or adoption of RFID technology. The survey invitations rolled out in two batches of 3'680 e-mail invitations and 1'283 manually completed Internet webforms. In the *third phase* the empirical data of 111 survey respondents is presented and discussed.

The structure of this article is as follows: The following section 2 provides insight to the interviews that were conducted with RFID experts from international companies and organisations. Section 3 introduces the survey research method. Section 4 presents the survey data of selected questions and discusses the findings by testing four hypotheses. Section 5 draws the conclusion where and what room for improvement there is by the RFID industry in its daily work with the adoption and diffusion of RFID.

2. Industry Interviews

This section outlines the first phase of the research. Three interviews with RFID experts at international companies and organisations engaged in consulting, system integration, soft- and hardware, and retail are conducted. Due to confidentiality obligations the names of the companies/organisations and the interviewees' names are made anonymous. The in-depth interviews (Johnson, 2001) are semi-structured and conducted partly for exploration purposes, partly for testing of the survey questions. The authors committed to keeping the names of the entities and interviewees confidential. Two main subjects are addressed in the interviews: The industry's views and opinions on regulation by law (radio spectrum, database, and privacy) and the RFID industry's relationship to consumers.

2.1 Industry's Experience with Regulation by Law

Three fields of regulation by law are addressed in the interviews: radio spectrum, database regulation, and privacy protection. The interviewed companies and organisations are aware of the current radio spectrum regulations. They welcome the harmonisation of radio spectrum for RFID but note that further engagement in this respect is necessary. Radio spectrum incompatibility is not only an issue between the different spectrum regions 1, 2 and 3 (ITU, 2005). There

are, for instance, also radio spectrum issues within the European member states (region 1) despite regulatory provisions by the European Commission to adopt the harmonisation of radio spectrum for RFID devices operating in the ultra high spectrum band (UHF) by the end of May 2007 (European Commission 2006/804/EC). In many EU member states the conditions for the availability and efficient use of radio spectrum for RFID devices in the spectrum bandwidth between 865 and 868 MHz have been adopted. But this still does not rule out compatibility problems between different countries. The use of a certain bandwidth in one country is not necessarily possible in the next country. Regulation can become an inhibitor.

“So [...] even though the EU regulation or proposal was there, you still had countries like Italy and Spain that had not freed up that spectrum because it was used by the military. So discussions that we had were an issue: we had to get a specific site license to do a pilot. So if we wanted to run a pilot with an EPC-oriented tag or UHF tag specifically we had to get a license. So that actually had helped *break the market, to slow down the market* in places like Italy. Two things happened there: a) it did *not accelerate* as quickly as it should have, there; and b) they started looking at other technologies, high spectrum instead.” (Interview with Company A; authors’ emphasis).

Indeed, the Commission of the European Communities (2006) revealed that slightly more than a third of the survey respondents do not believe that harmonisation of the radio spectrum between 865 and 868 MHz is sufficient to accelerate the establishment of a fully functioning internal market. The interview partners also all confirm that since a few years the RFID discussion and regulation debate is moving away from radio spectrum towards privacy issues. Two interview partners are more critical of the way the issues around privacy have evolved. On the one hand, one industry partner acknowledges that the way the industry appeased initial consumer concerns a few years ago has left a wrong impression of the RFID industry. On the other hand, in the industry’s perspective, consumer organisations were just hyping scenarios that were technically impossible:

"[...] a lot of the things we have today are not really relevant to privacy. And there really has been a hype by some organizations that pushed this privacy problem. I do not say there is no problem at all. But it was pushed in a way which was sometimes *not really realistic*. I mean if you look at [...] the problem in retail [it is] often not that you have RFID; but that you have a [loyalty card]. And that gives you all information about the consumer already. Nobody cares about that. If there is an RFID on that is, in my opinion, not that important." (Interview with Company C; authors' emphasis).

This view of technically non-feasible claims by RFID opponents is replicated by the RFID expert at Company B:

"So I pick up those things [by the consumer groups and RFID opponents] and go back to my engineering colleagues and say 'well, this is what they claim, this is what they throw against us'. And they say 'This can never happen because it cannot work. You cannot do this. It is technically impossible, physics is not right. You cannot do this.'".

Another partner argues similarly but more distinctly insofar as the privacy debate evolved because the regulator focussed more on consumer organisations. It is understood here that the miscommunication a few years ago between the legal regulator, consumer groups, and the RFID industry fostered the distrust. At that early experimental RFID phase a few years ago the industry could not yet participate in the debate because

"[...] the privacy debate specifically focused on the end result of an RFID enabled world, basically. And tries to emphasize *what could be done as if this could be done already today*, leading to a situation where you have, on the one hand, pressure groups [...] who singled out RFID as very heavily threatening technology for privacy and data protection. And regulators who came in to look at this issue [...] and had practically two choices to inform themselves: one were those pressure groups and the others were businesses who were still in very early

experimental phases of RFID and could not say much or could only talk about the end vision. [...] And so it somehow flawed impression of what is possible if RFID developed, among non-technical people, lawyers and regulators. [This lead] to a situation where now [...] perceived threats are actually what we are talking about. And *perceived* threats are what regulators actually try to address in their regulation. Not real threats.” (Interview with Company B; authors’ emphasis).

Such *perceived* threats seem to form today’s political agenda. It is argued that privacy is a thankful political agenda. It involves all people and every interested citizen can participate in the debate. Privacy groups have been more successful in convincing the public of lasting negative effects on privacy rights (Xiao et al., 2007). This has catered distrust in the adoption and diffusion of RFID technology. Whether the perception meets the technical possibilities and legal provisions is doubted.

“Privacy is a very interesting part because many, many people have very diffused concerns about privacy. Many of the privacy arguments are intuitively understandable to a whole lot of people. I mean I would not rule myself out there. And I think nobody really can. And so you can really play ball with those fears in the way that you say: ‘Well, I am the guardian, I protect you. And there is a new technology, some people say it is scary, I do not necessarily believe that, but I will take care that it does not become scary, and I will make sure that privacy is protected with that new technology’.” (Interview with Company B).

Aside from these radio spectrum and privacy regulations the third regulation-related topic addressed to the interview partners – database regulation – does not seem to be an issue with which the industry is yet much concerned. The next section on consumers deliberates on this perception.

2.2 Industry's Experience with Consumers (General Public)

Either there is not much awareness for database regulation, or there is awareness but the applicability is seen somewhere in the future because current deployment of RFID is mainly case and pallet level oriented.

“[T]he data that is in the database is not consumer oriented. It's at case and pallet level and it is supply chain oriented. However, when RFID starts to adopt across the supply chain from the manufacturer all the way down to the retailer and on to the shop floor, you are going to have a lot of data sharing. And you are going to have multiple databases [but] we are not there yet. We are far from item-level [tagging]. But at least we can work at a regulation now to put it in place rather than inhibiting it.” (Interview with Company A).

A full scale item-level situation in retail, for instance, is likely to be realised only in the next ten to fifteen years. The read reliability needs to increase and the tag cost needs to decrease.

“[T]echnically speaking we can do item level already now. [...] It is more that customers currently don't accept some high tech issue. I mean in the consumer product goods area there is just no market need yet for item-level tagging, mainly because it is still too expensive. [...] And secondly there are still severe technical issues to realize in order for the technology to be actually reliable enough. So that is why (i) reliability of technology at that level, plus (ii) cost is still a hindrance at item-level tagging.” (Interview with Company C).

This means that

“[t]oday we are not tagging at item level yet. So it is really not touching the consumer in any way today, at all. So I think it is good we start to raise this discussion and we need to start to set a framework. But in actual fact there are only very few [...] pilots at item level but it is not really touching the consumer today.” (Interview with Company A).

But in any case, despite the consumer not being in the RFID loop yet (except for pilot deployments), the industry, especially the retail industry, is dependent of the consumers. Privacy problems influence people's very decision whether or not to use a service. Emotional reactions and distrust to shopping are negatively related to how much people value their privacy and that privacy must be an essential element of RFID rollout (Rothensee and Spiekermann, 2008). The RFID industry is aware of this and takes the debate seriously:

"If you are exposed to consumer decision on a level like retailers are, you are very sensitive. [...] it is almost foolish to think that we would on a technology issue say 'well, we do not care about the people, we just do it'. It cannot go. [...] We certainly fully agree with [taking consumer concerns seriously]. We are retailers, right? People need to trust us to enter our stores [...]. We depend on the trust of our customers. An RFID business case [...] is a two-part thing: (i) 50% does the technology work and does it bring benefits to us, and (ii) 50% customers. Is there any customer that would not shop [in a] store anymore because you use RFID? Then that business case would certainly deteriorate quite a lot." (Interview with Company B).

This interviewee's view and Rothensee's and Spiekermann's (2008) research seem to counter-evidence the considerable scepticism of Kelly and Erickson (2005) whether retailers' economic self-interest will in fact really take a back seat to ethical concerns over customer privacy. Competitiveness plays a fair role for the RFID business case. Hence, it is reasonable to assume that the industry is not deploying RFID for purely altruistic reasons. But since trust is difficult to generate, easily shaken, and once shaken, extremely difficult to rebuild (Shneiderman in: Rothensee and Spiekermann (2008)), the industry is not likely to ignore the opinion of its valued customer.

Within such competitiveness RFID is one tool for expanding into economic markets, for instance, near-field communication. The customer will be directly involved in the technology and will have a direct benefit from the services.

“RFID is going to help us be more competitive. It is going to help make daily life easier. [...] Near-field communications [...] is touching the consumer [...] It is about putting an RFID tag and a reader on your phone and using it for payments, for bus transport, for things like that. And that touches directly to the consumer environment.” (Interview with Company A).

The problem seems to be, however, that there is a discrepancy between the industry’s and the consumers’ awareness of RFID. Whereas the RFID industry is obviously knowledgeable about the topic, people in general are not. Strickland and Hunt (2005) show in their survey that there is not a substantive understanding of the technology. The results of respondents are not better than random guessing. The education level of the sample was high. Thus here it is anticipated that the overall understanding of the technology is actually worse. This correlates with the experience of one interview partner:

“[...] well, the people are not necessarily not sensible, they are just not deep enough into the topic knowing the technology good enough to understand which is just a nice, although threatening, idea of what the potential future is, and what the reality of the technology is today and for the foreseeable future.” (Interview with Company B).

The interviews have helped generate a survey for the RFID industry on regulation by law and the consumer. The next section explains the survey methodology.

3. Survey Research Methodology

This section outlines the second phase of the research. The empirical data collected for this research is survey-based. Survey sample, survey design, and survey limitations are discussed.

3.1 Survey Design

Certain RFID opponents claim that the use of RFID is unethical (Albrecht and McIntyre, 2005). Notwithstanding such claims, RFID as topic is neither ethically nor politically inappropriate for a survey research (Sapsford, 2007). Therefore it is justified to collect the

missing data by engaging RFID stakeholders in a survey. To the best of the authors' knowledge, an accurate worldwide list of companies and organizations interested and involved in RFID technology, be it as suppliers, implementers, operators, or users does not exist. The population of companies or organisations engaged in RFID technology is unidentified. Because the count of certain populations will always remain unknown (Couper, 2000), it is suggested that with certain limitations, a sub-set of a population of companies and organizations engaging in RFID technology can be compiled using a web-based survey. This population will obviously not be a complete worldwide list of companies and organizations interested and involved in RFID technology. But it provides usable input nonetheless. Whereas it is acknowledged that many different online databases with companies and organisations engaged in RFID technology exist, it is maintained here that companies and organisations engaging in the emerging field of RFID technology will likely participate in either of the two online platforms of EPCglobal for standards, and RFID Journal for news.

3.2 Survey Sample

To compile a sub-set of a population it is argued here that the databases of EPCglobal and RFID Journal are a good starting point. EPCglobal is the leading subscriber-driven organisation comprised of industry leaders and organisations for industry-driven standards for the Electronic Product Code (EPC) to support the use of RFID (EPCglobal Inc.). RFID Journal claims to be the world's first independent and world's leading media source of RFID news and insights (RFID Journal). Both of these sources provide lists of companies and organisations engaging or interested in RFID.

For this particular survey, the unit of analysis is defined as a company or organisation, for which an employed individual completes the questionnaire acting as proxy (Rea and Parker, 2005; Yin, 2003). As this survey is conducted on a worldwide basis, two questions regarding the unit of analysis need to be answered: *First*, what happens with *national* companies or organisations that have several entities within a country? For national companies or organisations with several entities or representations in a country only one entity or representation (preferably the main/headquarter) is included in the

population. *Second*, what happens with *international* companies or organisations? For international companies and organisations every country, in which such company or organisation is located, is included in the population. Within each of these countries the same rule applies as for national companies or organisations: an international company or organisation is *surveyed only once per country*, even if such company or organisation has several entities or representations in a country.

A list of 1'321 companies and organisations engaged or interested in RFID is compiled from the EPCglobal and RFID Journal vendor databases. Based on 1'144 of these companies and organisations an extensive manual Internet search generates 4'963 contact addresses worldwide in 224 countries and geographical regions (depending on how the companies and organisations are structured globally). These 4'963 contacts receive an online invitation to participate in the authors' online survey. In total 724 survey invitations are undeliverable (e.g., postmail error). 4'239 survey invitations are delivered. A total of 185 invitees respond to the survey. Of these 185 survey respondents 74 are unusable (e.g., no answers), 11 survey respondents answer the questionnaire partially, and 100 survey respondents complete the questionnaire. For the remainder of this article only the 111 full and partial survey replies are relevant.

3.3 Survey Limitations

The survey comprises 6 parts with sixteen questions. All material questions of this survey on RFID are close-ended questions (Rea and Parker, 2005; Nardi, 2003), with the possibility of adding comments. Most rating questions use a 5 point Likert rating scale (Rea and Parker, 2005).

This web-based survey has limitations: *First*, the population of companies and organisations engaged in RFID technology is unknown which is why the two databases of EPCglobal and RFID Journal are used to compile a population. *Second*, anticipating that the response rate will be low, the survey is sent to the entire web-based population, leaving the survey respondents a certain self-bias to reply. *Third*, a few webpages in Eastern Europe and Asia Pacific do not provide any English webpage translation and the appropriate e-mail

contact or webform cannot not be found and are thus not included. *Fourth*, a few webpages do not provide any online contact, neither e-mail nor webforms and are thus not included. *Fifth*, the statistical analysis of the data in this survey is conducted under the two assumptions that (i) the sample is fully unbiased; and (ii) the distribution is normal according to the commonly understood bell-shaped curve (Rea and Parker, 2005).

Despite these possible sources of error it is suggested that the survey is a reasonable method for conducting this research. Using only the 100 full replies from the survey in calculating the margin of error (Rea and Parker, 2005) are conservative approaches. It is assumed for the analysis of this survey that a 95% confidence level with an error margin of 9.68% is sufficient to draw accurate findings from the data. However, the data is insufficient to draw generaliseable conclusions.

4. Findings

This section outlines the third phase of the research. It is divided into two main parts. In line with the interview layout in section 2 (Industry Interviews) the findings in this section are structured into the RFID industry's perspective of regulation by law (section 4.1) and the RFID industry's perspective of the consumers (section 4.2). On the one hand, within the sub-sections the survey results are grouped by industry (telecommunication, retail, label / printing, logistics, information technologies, healthcare / life science, electronics, consulting, and miscellaneous industries); on the other hand, they are grouped by geographical or political territory (USA, European Union, OECD, ITU regions 1 - 3). The authors give an overall overview of the results, pinpoint to certain *noticeable* results in the 10 charts showing the survey respondents' perspectives, and answer four hypotheses.

4.1 Industry's Experience with Regulation by Law

4.1.1 Radio spectrum, Database and Privacy Law

An abstract search on the Emerald Internet database provides 16 journal articles relating to RFID and *privacy* over several years; in 2007 for instance: Angeles (2007), Lee et al. (2007), Hingley et al.

(2007), Butters (2007), Attaran (2007), or Srivastava (2007); 1 journal article relating to RFID and *database* (____, 2005); and zero journals relating to RFID and *radio spectrum*.

Given this research focus, a first hypothesis can be stipulated.

H 1: *The RFID industry's problems with regulation range in descending order from privacy over database to radio spectrum regulation.*

H 1 is tested with the survey results of Chart 1, Chart 2, and Chart 3.

Spectrum regulation (Chart 1): Overall, by territory and industry, only a small percentage of 8% is unaware of radio spectrum regulation. Of the remaining survey respondents aware of the regulation, 44% have no or rarely problems, 22% have occasionally problems, and slightly more than 20% indicate having frequently or very frequently problems with radio spectrum regulation.

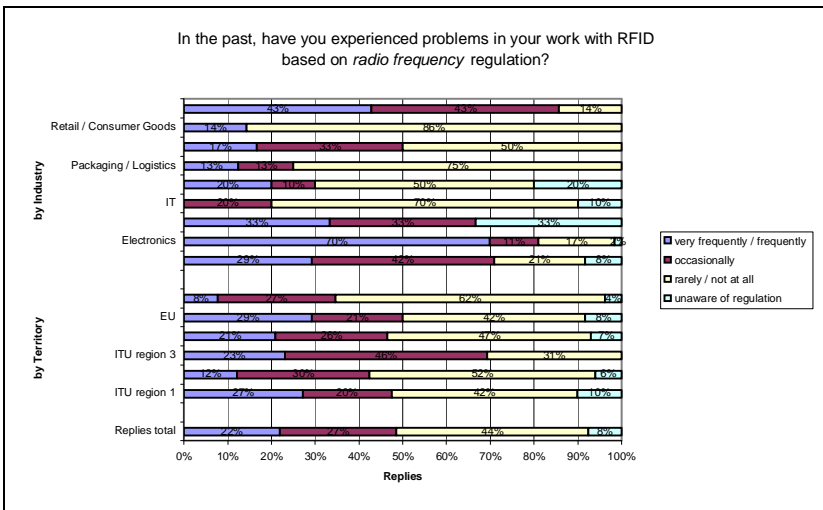

Chart 1: Replies to survey question on radio spectrum regulation.

By *territory*, between 0% and 10% of the responding companies and organisations indicate to be *unaware* of radio spectrum regulation. It is noticeable that survey respondents from ITU region 3 are all aware of spectrum regulation but at the same time have the highest percentage of very frequent problems with this regulation. By *industry*, the knowledge or lack of knowledge of radio spectrum regulation varies. The telecom and ISV; retail and consumer goods; label, printing and paper; as well as the packaging and logistics industries are all aware of radio spectrum regulation. The remaining IT, healthcare and life science, electronics, consulting, and miscellaneous industries are all unaware of the radio spectrum regulation. Noticeable among the unaware industries is that the healthcare and life science industry shows considerable high lack of knowledge (33%).

Database regulation (Chart 2): *Overall* by territory and industry, on the one hand, the unawareness about database regulation increases to 19% as compared to the results in Chart 1. On the other hand, 68% indicate not having any or only rarely problems at all with database regulation. 10% of the survey respondents have occasionally problems with the regulation. Finally, only a small percentage encounters frequently or very frequently problems with database regulation.

Between 13% and 27% of all survey respondents grouped by *territory* claim to have no knowledge about database regulation. This lack of knowledge about database regulation pervades through the industries as well but increases significantly for certain industries. Hence, by *industry*, it is noticeable that the telecom and ISV industry is the only industry entirely aware of database regulation. In contrast, the healthcare and life science; retail and consumer goods; and the miscellaneous industries have a high percentage of lack of knowledge on database regulation (approximately 40%). The healthcare and life science industry also deviates from the overall pattern in that 40% encounter occasional problems with database regulation.

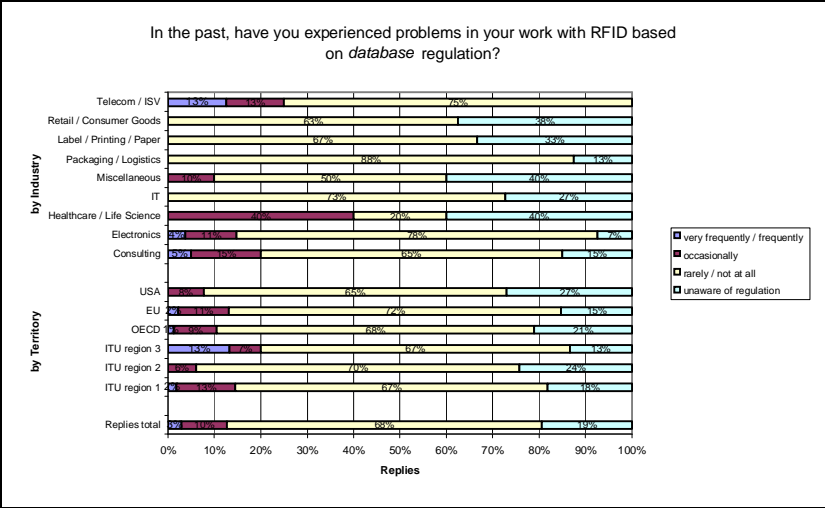

Chart 2: Replies to survey question on database regulation.

Privacy regulation (Chart 3): Overall by territory and industry there is a small percentage of 9% that is unaware of privacy regulation and 64% does not have any or only rarely problems with data privacy regulation. About 20% have occasionally problems. Only a few indicate having frequently or very frequently issues with privacy regulations (6%).

By *territory*, only a small amount of approximately 10% or less of the survey respondents indicate being unaware of data privacy regulation. It is noticeable that also in this question about privacy regulation the survey respondents from ITU region 3 are all aware of data privacy. By *industry*, the telecom and ISV; retail and consumer goods; label printing and paper; as well as the packaging and logistics industries are all aware of data privacy regulation. It is noticeable and industry inherent – but not visible in Chart 3 due to the allocation of frequent and very frequent problems into one category in all the charts of this article – that the retail and consumer goods industry is the only industry that has *very frequent* problems. All the electronics and consulting industries in Chart 3 actually only have frequent problems with privacy regulation.

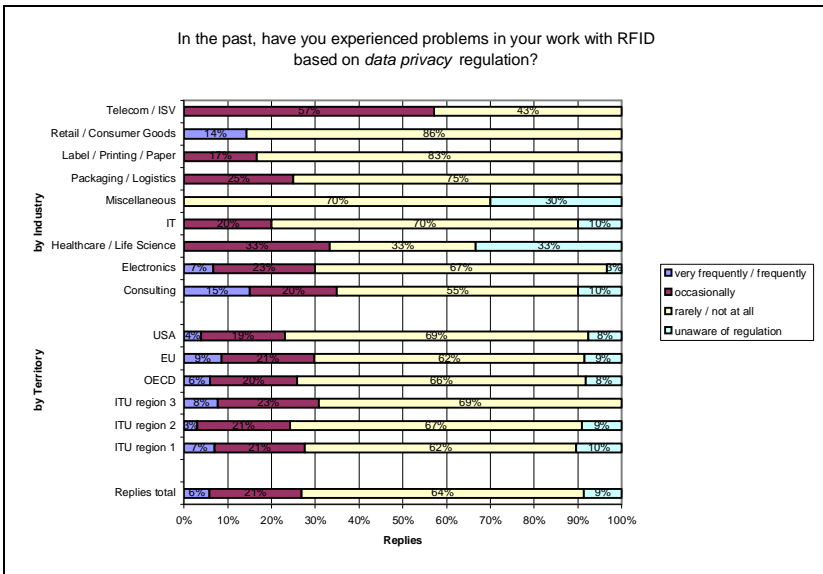

Chart 3: Replies to survey question on privacy regulation.

A comparison of Chart 1, Chart 2, and Chart 3 shows that of all three regulations the database regulation is the least known regulation. The awareness of radio spectrum and data privacy regulation is much higher. The telecom and ISV are the best informed industry. It is argued here that the telecommunication regulation of the 1990s has promoted the awareness of applicable regulation in this industry. Furthermore the healthcare and life science industry shows a higher trust in the RFID regulation. Here it is argued that the strong regulation in the healthcare and life science industry has strengthened such trust.

Chart 1 shows the most frequent or very frequent problems with radio spectrum regulation. Chart 2 on database regulation shows a high lack of knowledge about database regulation. Chart 3 on privacy regulation shows the most regular response pattern. Based on the emphasis given in this research, from an industry perspective one would expect a different allocation and importance of the topics in the *journal articles*. *First*, one would expect most articles to research radio spectrum regulation because this is where the industry has the most

problems in adoption and diffusion of RFID technology (total of 50% of occasional, frequent and very frequent problems in Chart 1). It has also been suggested that radio spectrum is fundamental to the Internet of Things, and its allocation is possibly the most important key issue for many regulators and government agencies (European Commission - Information Society and Media Directorate General, 2006). Nonetheless, within the articles reviewed, there is no journal article on this topic. *Second*, one would expect there to be the least articles about database regulation because a large part of the RFID industry is unaware of such regulation and because there are the least problems with database regulation (Chart 2). Indeed, within the articles reviewed, there is only one article on RFID and databases. *Third*, one would expect only a few articles about privacy regulation because, on the one hand, the overall awareness about privacy issues is good, and, on the other hand, 50% of the survey respondents indicate having some sort of problems with the regulation. But as the abstract search on the Emerald Internet database reveals, the contrary is true: privacy regulation is by far the most topical journal article subject.

Given these results in Charts 1 to 3, H 1 cannot be confirmed. Privacy is the most contemporary research topic; database is the second most topical research subject, yet with only one article almost similarly insignificant as the inexistent articles about radio spectrum.

4.1.2 Legislator, Lawyers and Judges

Regulation by law involves the legislator, lawyers and judges. *First*, in one of the interviews an RFID industry partner alludes to the flawed impression by the regulator (legislator) influenced by pressure groups. *Second*, the RFID industry indicates in the survey that 50% of the survey respondents do not engage any legal experts for legal questions with RFID. One quarter of the survey respondents uses internal legal experts and the remaining quarter outsources the legal issues to external legal experts. *Third*, to the knowledge of the authors there are not many court cases involving radio spectrum, database or privacy regulation relating to RFID technology.

Given these facts about the legal regulator on RFID technology, a second hypothesis can be stipulated.

H 2: *From an RFID industry perspective the legal regulator's expertise on RFID technology is insufficient.*

H 2 is tested with the survey results of Chart 4, Chart 5, and Chart 6:

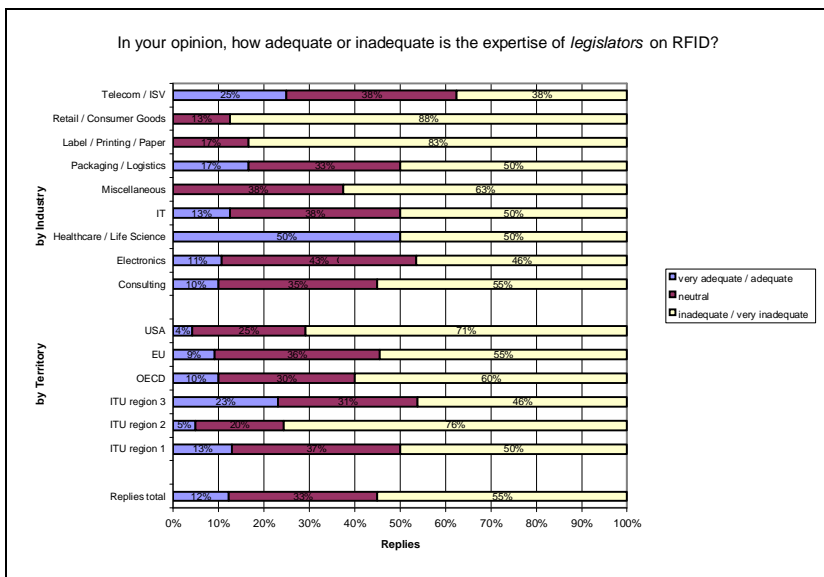

Chart 4: Replies to survey question on legislator's RFID expertise.

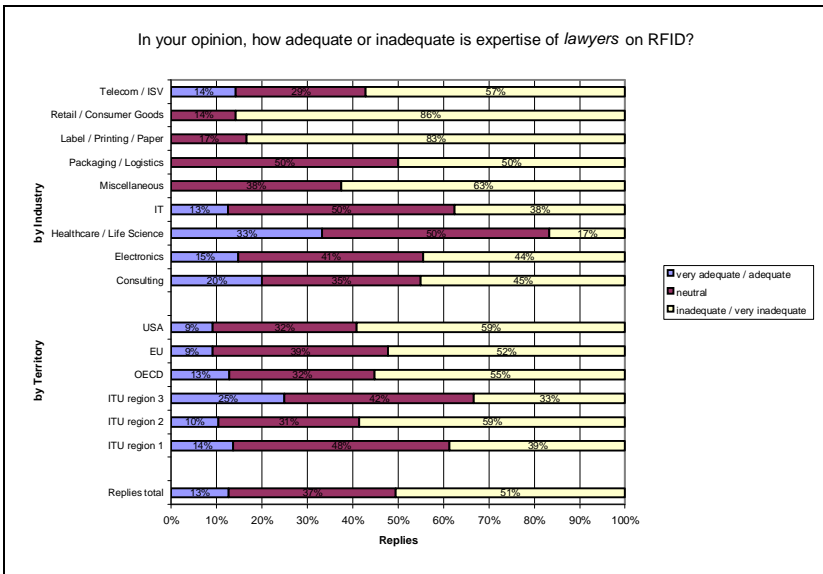

Chart 5: Replies to survey question on the lawyers' RFID expertise.

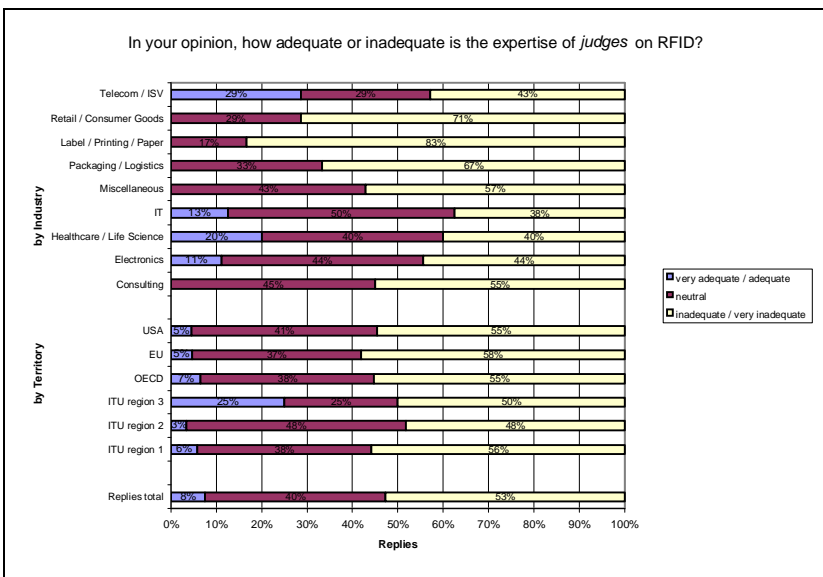

Chart 6: Replies to survey question on the judges' RFID expertise.

The survey respondents provide feedback on their experience with the legal regulator's expertise on RFID technology. The responses about the legislator's expertise (Chart 4), the lawyers' expertise (Chart 5), and the judges' expertise (Chart 6) by *territory* are similar. Only a minority (approximately 10%) of the survey respondents in all territories indicate that the expertise of the legislator, lawyers and judges is adequate or even very adequate. A constant amount of approximately 30% to 40% rest neutral on the question. The remaining 50% to 70% of the responding companies and organisations think that the legislator, lawyers and judges have *inadequate* or very *inadequate* expertise. Two points are noticeable: *First*, of all bad marks given by the survey respondents, the legislator qualifies as having the best (of the bad) expertise (Chart 4), followed by the lawyers' slightly worse expertise (Chart 5), ending with the expertise of the judges being the worst (Chart 6). *Second*, the ITU region 3 distributes high marks (approximately 25%) for adequate expertise to legislators, lawyers and judges.

Within the responses by *industry* there are five industries that trust more in the abilities of the legal regulator giving some adequate and very adequate marks: telecom and ISV; IT; healthcare and life sciences; and electronics (Chart 4, Chart 5 and Chart 6). The retail and consumer goods, label and printing as well as the miscellaneous industries distrust more in the legal regulator and do *not* have adequate or very adequate opinion of the legal support (Chart 4, Chart 5 and Chart 6). The packaging and logistics as well as the consulting industries do not show such a constant response pattern.

The discussion on the adequacy of the legal regulator's RFID expertise shows that to a large part the RFID industry does not believe that legal support on RFID technology is in good legal hands. If one acknowledges that there have not been many court decisions on RFID technology, then it is understandable that the RFID industry would assess the judiciary's expertise as inadequate or very inadequate. However, of more concern is that the legislator and lawyers get bad marks from the industry as well. The RFID industry does not seem to see itself represented satisfactorily by the legislator and lawyers.

Given these results in Charts 4 to 6, H 2 can be confirmed. The survey respondents see themselves badly represented by the legal regulator.

Within this bad assessment, the lawyers get the best (of the bad), the legislator the second worst, and the judges the worst marks.

4.2 Industry's Experience with Consumers (General Public)

4.2.1 Knowledge Level of Consumers

In 2006 the European Commission issued an online survey on the challenges, opportunities, and threats of RFID (Commission of the European Communities, 2006). In that survey the availability of information for the consumer to make an informed decision about RFID is rated as insufficient by approximately 60% of the survey respondents, whereby nearly 65% of the survey respondents are citizens and not companies or organisations. As by definition of that survey all the survey respondents are aware of RFID technology, the Commission anticipates that there is a significant RFID knowledge gap by the general public (Commission of the European Communities, 2007). If the consumer has insufficient information to make an informed decision then the consumer is obviously not knowledgeable about the topic.

Given that the majority of the citizens perceive there to be insufficient information on RFID for the consumer, a third hypothesis can be stipulated.

H 3: *From an RFID industry perspective the consumer (general public) is badly informed about RFID technology.*

H 3 is tested with the survey results of Chart 7:

Overall, only a very small percentage of all survey respondents by territory view the knowledge of the general public with regard to RFID as good or even very good (6%). For approximately 10% of the companies and organisations participating in the survey the knowledge of the general public is very bad. The majority of 65% view the knowledge to be bad or even very bad. The remainder is neutral (Chart 7).

By *territory*, all the respondents assess the consumers' knowledge good or even very good, even if only by a small percentage. By *industry*, however, the retail and consumer goods, label and printing,

miscellaneous, and healthcare and life science industries view the general public's knowledge on RFID to be bad or even very bad. Noticeable is the high percentage of bad or even very bad classification by the retail and consumer goods industry. The healthcare and life science industry stands out by only having a high (50%) neutral opinion of the general public's RFID understanding.

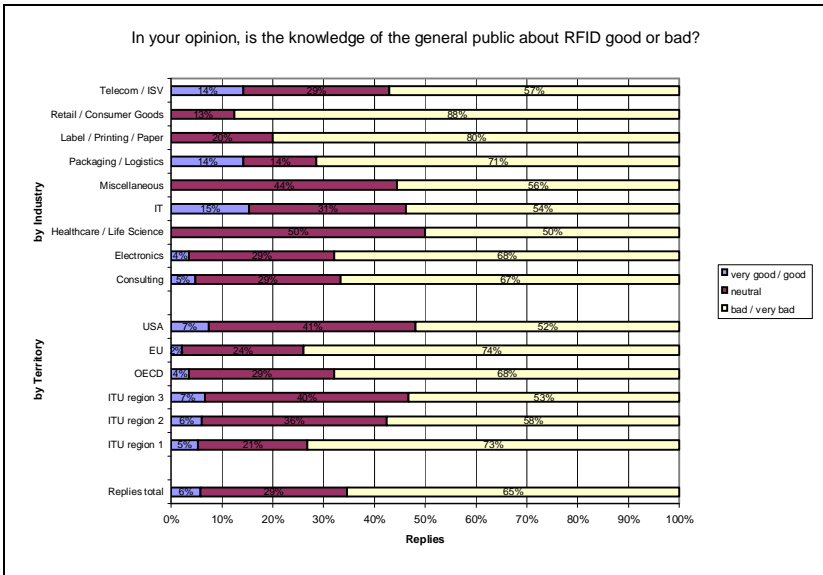

Chart 7: Replies to survey question about the general public's knowledge on RFID.

Given these results in Chart 7, H3 can be confirmed. The respondents of this online survey perceive the consumer (general public) to be badly informed about RFID technology.

4.2.2 Information Policy to Consumers

Confirmation of H 3 leads to the question where the communication to the consumer fails. Diffusion of innovation theory (Rogers, 2003) explains the adoption and diffusion of different types of new information and communication technologies (Kim and Galliers, 2004).

Diffusion is a particular form of *communication*. Diffusion communicates a new idea from one party to another (or several other) party (parties). Among the many different characteristics of innovation (Rogers, 2003; Wolfe, 1994; Nutley and Davies, 2000; Swanson and Ramiller, 2004; Greenhalgh et al., 2004, Damanpour and Wischnevsky, 2006) potential adopters engage in information seeking behaviours to learn about the expected consequences of using the innovation (Juban and Wyld, 2004).

Given that the RFID industry intends to widely diffuse RFID as technological innovation, a fourth and last hypothesis can be stipulated.

H 4: *The RFID industry provides the best information about RFID technology to the consumer.*

H 4 is tested with the survey results of Chart 8, Chart 9, and Chart 10.

RFID Industry (Chart 8): Overall 21% of the survey respondents believe the general public is informed well or very well by the RFID industry, whereas 37% believe the information by the industry is very bad or bad. The remainder of about 40% is neutral.

By *territory*, it is noticeable half of the survey respondents in ITU region 3 believe the general public is well informed by the industry. Furthermore, on the European continent (EU and ITU 1) the information policy seems to be less good (13 % and 14%) than in the other territories. Noticeable is also that in ITU region 3 there are 50% very good or good marks for the information policy.

By *industry*, a similar response pattern is shown as the responses by territory, with the following differences: The label, printing and paper industry does not believe the general public is well informed by the RFID industry itself. Noticeable is also that the telecom and ISV; retail and consumer goods; and label, printing and paper industries give high bad marks for the information policy by the RFID industry itself (approximately 70%). Furthermore, the label, printing and paper industry only gives bad marks altogether or remains neutral on the question.

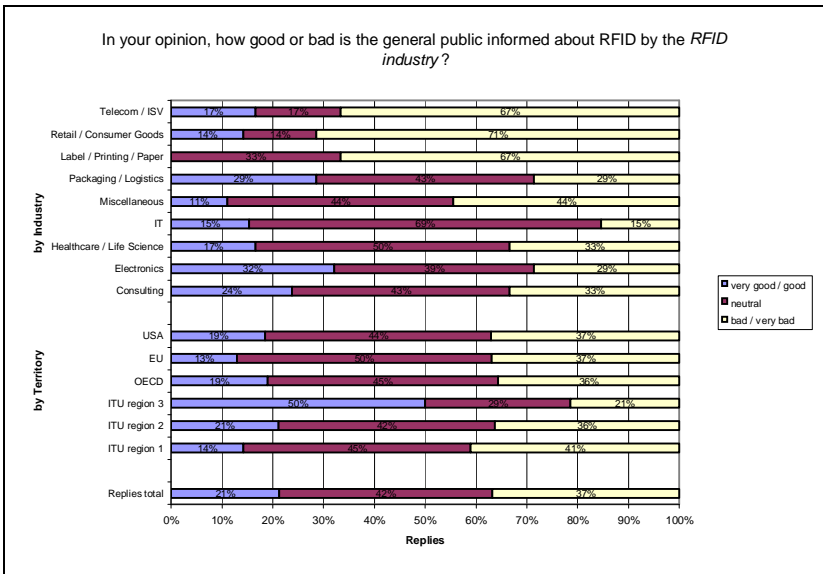

Chart 8: Replies to survey question on the information by the RFID industry.

Regulator (Chart 9): Overall, the results get significantly worse in the assessment of RFID information policy by the RFID regulatory. Only 7% of the respondents believe the legal regulator has a good RFID information policy. 63% believe the information policy is bad or even very bad. Approximately a third remains neutral.

By *territory* the USA gives the best assessment on information policy to the legal regulator (12%), whereas in the EU the very good or good marks drop to 2%. The response allocation by *industry* shows that the telecom and ISV; retail and consumer goods; label, printing and paper; packaging and logistics; IT; and miscellaneous industries give only either bad or very bad marks to the information policy by the legal regulator, or remain neutral.

As compared to the communication by the RFID industry (Chart 8), the information policy by the RFID regulator (both by industry and territory) shows increased replies for the classifications bad and very bad (Chart 9). Only the healthcare and life science; electronics; and consulting industries have certain good or very good opinion on the information policy by the RFID legal regulator.

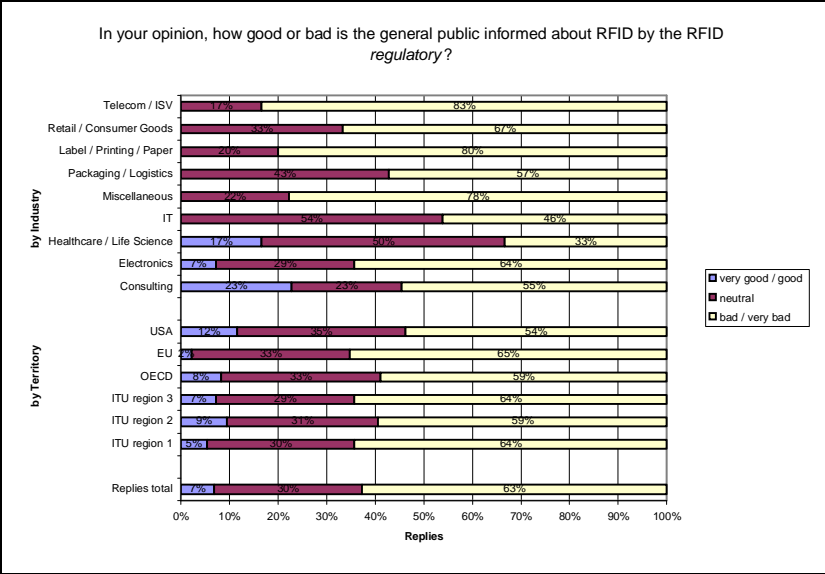

Chart 9: Replies to survey question on the information by the regulator.

Consumer organisations (Chart 10): As compared to Chart 8 and Chart 9, Chart 10 shows overall (by both industry and territory) a slightly more fragmented result. In direct comparison to the information policy by the legal regulator the information policy by consumer organisations improves slightly. 10% assess the information policy as good or very good, about 60% assess the information policy to be bad or even very bad, and the remainder of about 30% remains neutral on the question.

Within the division by *territory* the relatively high peak of good assessments by the survey respondents in ITU region 3 is noticeable. The allocation by *industry* shows furthermore that only the telecom and ISV; electronics; and consulting industry view the information by RFID consumer organisations as good, whereas the other six industries do not give any good points in this respect.

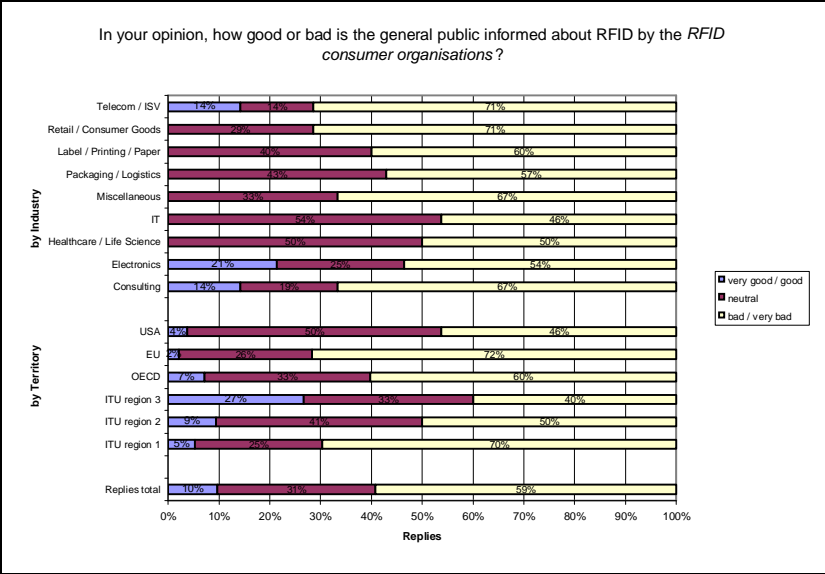

Chart 10: Replies to survey question on the information by consumer organisations.

Given these results in Charts 8, 9, and 10, H 4 can be confirmed. The respondents of the survey perceive the consumer (general public) to be badly informed about RFID technology whereby the legal regulator provides the worst information, followed by consumer organisations. The RFID industry gives itself the best marks on information policy to the consumers.

5. Conclusion

This article provides insight to the RFID industry’s perspective of both regulation by law and the consumers. Four hypotheses have been tested, yielding the following results:

Number	Hypothesis	Result
H 1	The RFID industry's problems with regulation range in descending order from privacy over database to radio spectrum regulation.	Rejected
H 2	From an RFID industry perspective the legal regulator's expertise on RFID technology is insufficient.	Confirmed
H 3	From an RFID industry perspective the consumer (general public) is badly in-formed about RFID technology.	Confirmed
H 4	The RFID industry provides the best information about RFID technology to the consumer.	Confirmed

Table 1: Summary hypotheses.

The analysis of this research shows that:

1. Whereas the RFID industry indicates having the most problems with radio spectrum regulation, (scholarly) research focuses mostly on privacy regulation.
2. In all three categories of regulation by law (legislator, lawyers, judges), the perception by the RFID industry of the legal regulator's expertise of RFID technology is bad.
3. From an RFID industry perspective the general public is badly informed about RFID technology.
4. The information policy to the consumer is assessed as bad. Within this bad information policy the RFID industry believes it provides the best information. Second best information policy comes from consumer organisations. The worst information policy is by the legal regulator.

Overall, one can conclude that – from an RFID industry perspective – both the regulator and the consumer have insufficient knowledge and support with regard to the adoption and diffusion of RFID. Following

three recommendations are proposed by the authors to the RFID industry to support the adoption and diffusion of RFID:

First, the RFID industry should engage in a better dialogue with the legal regulator, for instance, by knowledge exchange between the RFID industry and in-house and external legal counsel to promote the constructive dialogue about RFID technology. It is acknowledged here that not everyone can and should become an expert on every topic. But this research suggests that there is room for improvement in the exchange of professional expertise.

Second, the RFID industry should strengthen its knowledge on applicable regulation, for instance, by working closer together with the legal regulator, especially the in-house and external lawyers. This research suggests that the RFID industry is unaware of certain regulations that could be used in its favour.

Third, the RFID industry should re-evaluate its information policy to the general public. Either the counter-information by the consumer organisations and the legal regulator are much better, or the RFID industry's information policy is not yet there where it should and could be to promote RFID technology to its advantage.

References

- _____. (2005), "The Pros and Cons of RFID: Data Analysis", *Strategic Direction*, Vol. 21, No. 5, pp. 24 et seq.
- Albrecht, K. & McIntyre, L. (2005), *Spychips: How Major Corporations and Government Plan to Track Your Every Move with RFID*, Nelson Current, Nashville, Tennessee.
- Angeles, R. (2007), "An Empirical Study of the Anticipated Consumer Response to RFID Product Item Tagging", *Industrial Management & Data Systems*, Vol. 107, No. 4, pp. 461 et seq.
- Attaran, M. (2007), "RFID: An Enabler of Supply Chain Operations", *Supply Chain Management: An International Journal*, Vol. 12, No. 4, pp. 249 et seq.
- Butters, A. (2007), "RFID Systems, Standards and Privacy within Libraries", *The Electronic Library*, Vol. 25, No. 4, pp. 430 et seq.

- Commission of the European Communities (2006), *The RFID Revolution: Your Voice on the Challenge, Opportunities and Threats*, Brussels.
- Commission of the European Communities (2007), *Results of the Public Online Consultation on Future Radio Frequency Identification Technology Policy "The RFID Revolution: Your Voice on the Challenges, Opportunities and Threats"*, Brussels.
- Couper, M.P. (2000), "Web Surveys. A Review of Issues and Approaches", *Public Opinion Quarterly*, Vol. 64, pp. 464 et seq.
- Damanpour, F. and Wischnevsky, J.D. (2006), "Research on Innovation in Organizations: Distinguishing Innovation-Generating from Innovation-Adopting Organizations", *Journal of Engineering and Technology Management*, Vol. 23, pp. 269 et seq.
- EPCglobal Inc. Last accessed on 19 December 2008, at <http://www.epcglobalinc.org> (partial subscriber webpage).
- European Commission 2006/804/EC, Commission Decision of 23 November 2006 on Harmonisation of the Radio Frequency Identification (RFID) Devices Operating in the Ultra High Frequency (UHF) Band.
- European Commission - Information Society and Media Directorate General (2006), *From RFID to the Internet of Things - Pervasive Networked Systems*, Office for Publications of the European Commission, Luxembourg.
- Greenhalgh, T., et al. (2004), "Diffusion of Innovations in Service Organizations: Systematic Review and Recommendations", *The Milbank Quarterly*, Vol. 82, No. 4, pp. 581 et seq.
- Hingley, M., Taylor, S. and Ellis, C. (2007), "Radio Frequency Identification Tagging: Supplier Attitudes to Implementation in the Grocery Retail Sector", *International Journal of Retail & Distribution Management*, Vol. 35, No. 10, pp. 803 et seq.
- ITU (2005), *Radio Regulation*.
- Johnson, J.M. (2001), "In-Depth Interviewing", in J.F. Gubrium and J.A. Holstein (Ed.), *Handbook of Interview Research - Context & Method*, Sage, London, pp. 103 et seq.

- Juban, R.L. and Wyld, D.C. (2004), "Would You Like Chips With That?: Consumer Perspectives of RFID", *Management Research News*, Vol. 27, No. 11/12, pp. 29 et seq.
- Kelly, E.P. and Erickson, G.S. (2005), "RFID Tags: Commercial Applications v. Privacy Rights", *Industrial Management & Data Systems*, Vol. 105, No. 6, pp. 703 et seq.
- Kim, C. and Galliers, R.D. (2004), "Toward a Diffusion Model for Internet Systems", *Internet Research*, Vol. 14, No. 2, pp. 155 et seq.
- Lee, S.M., Park, S., Yoon, S.N. & Yeon, S. (2007), "RFID Based Ubiquitous Commerce and Consumer Trust", *Industrial Management & Data Systems*, Vol. 107, No. 5, pp. 605 et seq.
- Nardi, P.M. (2003), *Doing Survey Research - A Guide to Quantitative Methods*, Pearson Education, Boston.
- Nutley, S. and Davies, H.T.O. (2000), "Making a Reality of Evidence-Based Practice: Some Lessons from the Diffusion of Innovations", *Public Money & Management*, Vol. 20, No. 4, pp. 35 et seq.
- Rea, L.M. and Parker, R.A. (2005), *Designing & Conducting Survey Research - A Comprehensive Guide*, 3rd ed., Jossey-Bass, San Francisco.
- RFID Journal. Last accessed on 19 December 2008, at: <http://www.rfidjournal.com> (partial subscriber webpage).
- Rogers, E.M. (2003), *Diffusion of Innovation*, 5th ed., Free Press, New York.
- Rothensee, M. and Spiekermann, S. (2008), "Between Extreme Rejection and Cautious Acceptance - Consumers' Reactions to RFID-Based IS in Retail", *Social Science Computer Review*, Vol. 26, No. 1, pp. 75 et seq.
- Sapsford, R. (2007), *Survey Research*, 2nd ed., Sage Publication, London.
- Srivastava, L. (2007), "Radio Frequency Identification: Ubiquity for Humanity", *Info*, Vol. 9, No. 1, pp. 4 et seq.
- Strickland, L.S. and Hunt, L.E. (2005), "Technology, Security, and Individual Privacy: New Tools, New Threats, and New Public

- Perceptions", *Journal of the American Society for Information Science and Technology*, Vol. 56, No. 3, pp. 221 et seq.
- Swanson, E.B. & Ramiller, N.C. (2004), "Innovating Mindfully with Information Technology", *MIS Quarterly*, Vol. 28, No. 4, pp. 553 et seq.
- Wolfe, R.A. (1994), "Organizational Innovation: Review, Critique and Suggested Research Directions", *Journal of Management Studies*, Vol. 31, No. 3, pp. 405 et seq.
- Xiao, Y., Yu, S., Wu, K., Ni, Q., Janecek, C. & Nordstad, J. (2007), "Radio Frequency Identification: Technologies, Applications, and Research Issues", *Wireless Communications Mobile Computing*, Vol. 7, No. 4, pp. 457 et seq.
- Yin, R.K. (2003), *Case Study Research*, 3rd ed., Sage Publications, Thousand Oaks.

5. CONCEPT ARTICLE

The Battle of Concepts: Ubiquitous Computing, Pervasive Computing and Ambient Intelligence in Mass Media

Daniel Ronzani

Published in: Ubiquitous Computing and
Communication Journal (UBICC)
Vol. 4, No. 2, online PDF, pp. 1-11

Reprint and publication of author generated version of the article with courtesy of Ubiquitous Computing and Communication Journal (20 January 2009). Copyright with UBICC.

Changes to format and references.

The Battle of Concepts: Ubiquitous Computing, Pervasive Computing and Ambient Intelligence in Mass Media

Daniel Ronzani

Copenhagen Business School, Centre for Applied ICT,
Howitzvej 60, DK-2000 Frederiksberg
dr.inf@cbs.dk

Abstract

For the past two decades the concepts of ubiquitous computing, pervasive computing and ambient intelligence have been used to describe the Internet of Things. This paper studies how the three concepts of ubiquitous computing, pervasive computing and ambient intelligence have evolved (or not evolved) through and in mass media. It shows how the concepts have competed with each other in an almost Darwinist way. It suggests that by and large the three concepts are described by the same attributes. However, the success of the implementation of a new concept like ambient intelligence in the established realms of ubiquitous computing and pervasive computing requires a closer link to the public.

Keywords

Ubiquitous computing, pervasive computing, ambient intelligence, mass media, newspaper.

1 Introduction

In today's technology based environment unobtrusive wireless technology is often described as ubiquitous computing, pervasive computing or ambient intelligence. Xerox introduced the term ubiquitous computing, IBM coined the term pervasive computing and Philips selected the expression ambient intelligence.

It seems difficult to distinguish ambient intelligence from older concepts of pervasive computing and ubiquitous computing, especially if even the creators and sponsors of these terms seem to use them interchangeably:

1. The late Mark Weiser at Xerox PARC envisioned in his pioneering research computers not as personal computers, but as a pervasive part of everyday life [1] and asked whether the intelligent agent was the metaphor for the computer of the future [2];
2. Hansmann et al. (2003) from IBM refer to the slogan "everywhere at anytime" as being – in a nutshell – the goal of both pervasive or ubiquitous computing, and talk about decentralised intelligence [3];
3. The Information Society Technologies Advisory Group in the European Framework Program 6 notes that ubiquitous computing is one of the key technologies of ambient intelligence and that such vision is only possible if pervasive networks exist [4].

On the one hand, it has been suggested that the distinction between these terms remain purely academic [5]. On the other hand, there has been critique that ambient intelligence is not clearly distinguished from earlier concepts of pervasive computing or ubiquitous computing and that more effort might be needed to explain the nature of ambient intelligence. [6]

In light of the European Union's research policy in Framework Programme 7 it is justified to review such terms and views, and to sift out the similarities and differences in the past years between the original terms of ubiquitous computing, pervasive computing and ambient intelligence. The purpose of this paper is to show that the battle of concepts of ubiquitous computing, pervasive computing and ambient intelligence also takes place in daily communication (section

2). Because the concepts show only marginal differences, the introduction of a new concept is challenging. In the event of ambient intelligence, mass media analysis shows why and where the implementation failed to gain the same popularity as its rival concepts ubiquitous computing and pervasive computing (section 3). The analysis concludes by tentatively suggesting the establishment of own and distinct attributes for a new concept and to not only popularise it through mass media but to also associate it with a popular product or service (section 4).

2 Research Method

2.1 Why Traditional Newspapers Matter

In times of proliferating online services the question might arise why one should research traditional newspapers and not, for instance, online media. One might also question traditional newspapers as compared to scholarly journals. There are many reasons for focussing such research on traditional newspapers:

First, Gorman and McLean [7] note that although the audience for both US and UK newspapers steadily declined in circulation and readership after World War 2, the New York Times (USA) and the Times (UK) represent important newspapers throughout the 20th Century. They are bought, read and praised for their authoritativeness and comprehensive news coverage, and for serving as records of events. Newspapers have not only experienced changes encouraged by institutional development – i.e., from private forums for political views of the (often) sole owner towards separation of ownership and editorial function – but have responded in the past decade to the challenges of the new media by launching online newspapers. However, according to Gorman and McLean there are also reasons not to use online news for the research, but to concentrate on the traditional printed newspapers:

1. there seems to be a trade-off between the need for instant breaking news and accuracy; and
2. the boundaries of news, marketing and advertising become blurred on the Internet as there is often no clear distinction between opinion and factual information.

Publications on ubiquitous, pervasive and ambient technology are very unlikely to be instant breaking news. Speed of such news publication, here it is argued, plays a subordinate role. Whether a newspaper article on such topic is published today or tomorrow is generally irrelevant. What interests is not “quick and dirty” but accurate information. Whereas Internet news is appreciated for its topicality, it might be biased by advertising and marketing. The implementation, for instance, of Radio Frequency Identification (RFID) technology – a technology which is associated with the scope of the researched terms – has been marketed and advertised for the past few years by various supplying and integrating industry players. Thus using non-biased, or at least less biased, information sources such as (traditional) well researched newspapers is important for this analysis to avoid possibly sponsored influence.

Second, Manning [8] refers to Lupton and Chapman who stated that “[n]ews media are vital in mediating between specialised forums for the dissemination of medical and public health research and policy and the wider public”. According to these authors, news media generally has the ability to make professional domains accessible to much wider audiences through the public sphere. Grossberg et al. [9] argue that media serves public functions in two essential ways: It constitutes publicity by bringing information out to the open, and it constitutes a key portion of what is called the public sphere.

Aiming for accuracy (as compared to speed) one could argue that analysing the terms in scholarly journals would be more appropriate. Given, however, that ubiquitous, pervasive and ambient technology are very likely to be widely implemented in common products and everyday services in the next few years, reducing the analysis to a limited discussion among experts is inappropriate. Newspapers provide for the explanation of these technical terms to the public sphere. It is argued here that the widespread acceptance of such

wireless technology will to a large extent depend on the public opinion and not solely on the experts' views.

In summary, it is argued here that if newspapers

1. are accurate key information sources whereas online news are biased towards the breaking news (authority), and
2. support making professional domains more accessible to public (publicity),

then it is justified to research and analyse newspapers for the concepts ubiquitous computing, pervasive computing and ambient intelligence. Consequently, the next question to answer is which newspapers to analyse.

2.2 Empirical Sample

Gunter [10] regards surveys and content analysis as important research methods for media. He states that survey principles may also be applied to content analysis. He further notes that in putting together the content analysis the researcher must work through a number of stages of measuring and sampling:

First, the empirical sample needs to be determined, i.e., the textual element that is to be counted. In order to examine the common notion and daily use of the terms ubiquitous computing, pervasive computing and ambient intelligence this analysis focuses on technology articles in English written newspapers. Since the researched terms emanated in North America (ubiquitous computing and pervasive computing) and Europe (ambient intelligence) the data collection is limited to newspapers from these geographies. The selection criterion for the newspapers within these geographies is that they (a) are written in English language, (b) are generally considered distinguished newspapers whereby financial, conservative and liberal journalism is selected, (c) potentially have dedicated technology sections, and (d) are preferably internationally available.

Second, the population of content to be sampled needs to be determined. Gunter [10] notes that generally researchers must sample a subset of content since the universe content is too large to be analysed in full. Sampling in content analysis often takes place in

various steps. The researcher must determine, among others, source, parts, amount and period:

1. Source and sample: which content sources need to be sampled, i.e., which particular national or international newspapers are to be selected?

The following newspapers were reviewed in detail the Times, the Financial Times London and the Guardian for in the United Kingdom; in the United States the N.Y. Times, the Wall Street Journal and the Washington Post; and finally in Canada the National Post (former Financial Post) and the Toronto Star. The latter being a local, but quite widely distributed newspaper.

2. Parts: which parts of the newspaper need to be analysed?

The Factiva database [11] was searched for the Wall Street Journal and the LexisNexis database [12] for all other seven newspapers. Both databases provide according to statements of the editors the complete hardcopy version of the researched newspapers, excluding pictures and graphs. A wildcard was included for each term to allow a broad search: “ubiquitous comput*”, “pervasive comput*” and “ambient intellig*”.

3. Amount: what is the amount of editions of each newspaper to be analysed?

239 articles were retrieved that met the above search criteria. A total of 91 were dismissed. These dismissed articles used the terms to describe relations not relevant for this research, e.g., “ubiquitous computer mouse” or “pervasive computer security viruses”. In total 148 newspaper articles remained containing at least one of the researched terms.

4. Period: the period of time to cover in the survey.

Newspaper articles were reviewed as far back as 1982. However, the first of the 239 articles containing the wild-carded terms appeared only in 1987 (see Section 3.1.2). Newspapers have been reviewed for each full year until the end of 2006.

Table 1 shows the eight reviewed newspapers with the amount of articles per researched term. A minor amount of articles containing

both terms ubiquitous computing and pervasive computing is referenced twice, i.e., once in each respective column.

Newspapers	Country	ubiquitous computing	pervasive computing	ambient intelligence	Total
Financial Times London	UK	15	17	1	33
Guardian	UK	9	6	0	14
Times	UK	3	10	2	15
<i>Total UK</i>		27	33	3	63
N.Y. Times	USA	19	17	1	37
Wall Street Journal	USA	6	3	0	9
Washington Post	USA	5	6	0	11
<i>Total USA</i>		30	26	1	57
National Post	CDN	10	9	2	21
Toronto Star	CDN	1	6	0	7
<i>Total Canada</i>		11	15	2	28
Total		68	74	6	148

Table 1: Unit of Analysis.

Third, there might be additional features or attributes of the empirical sample about which data are also collected (see Section 3.1.1).

2.3 Triangulation in News Media?

Triangulation is a mix of humanistic and scientific research cultures that should replace the divide between qualitative and quantitative research methods [13]. It is a general strategy for gaining different perspectives on the same phenomenon with regard to reliability and validity [14].

One interface that bridges both qualitative and quantitative research methods is coding. On the one hand, Jensen [15] notes that textual output of media has been a central object of analysis in qualitative media studies. Thereby coding can be understood as resource for identifying and retrieving a given portion of text for examination of

structure, qualities or context. On the other hand, for quantitative research code may be taken as an account or representation of a portion of the field of study, capturing certain qualities of (in the case at hand) text for comparison and quantification.

In order to identify and examine the relevant articles and to compare the three terms with one another, the subsequent analysis is based on a qualitative analysis followed by a quantitative analysis. The qualitative analysis gives a chronological view through the three researched terms. But it also focuses on the coded attributes that the authors of the newspaper articles ascribe to them. The quantitative analysis provides the basis for comparing the frequency of the three terms and their pattern of appearance.

3 Analysis

Figure 1 shows the amount of articles published each year on the topics of ubiquitous computing, pervasive computing or ambient intelligence. The first relevant appearances were: 1990 for ubiquitous computing, 1994 for pervasive computing, and 1999 for ambient intelligence. Whereas the amount of article appearances of ubiquitous computing remained quite constant with about 4 articles on average per year as of 1990, sparking an increase around the years 1999 to 2001, there has been an exponential amount of articles referring to the term pervasive computing during the so-called dot.com bubble. But the interest in pervasive computing declined as fast as it rose. The average use of pervasive computing per year since 1994 is 6 articles. Finally, the number of articles on ambient intelligence has been relatively low ever since its first occurrence in 1999 with less than one reference in a newspaper article per year on average.

The aggregated picture of the three terms resembles the life stages of a product. For analysis purposes the contributions to ubiquitous computing, pervasive computing and ambient intelligence were split into the following 4 phases that compare to that of a product lifecycle:

- Phase 1: 1990 to 1992, "Introduction";
- Phase 2: 1993 to 1996, "Growth";
- Phase 3: 1997 to 2002, "Maturity"; and
- Phase 4: 2003 to 2006, "Decline".

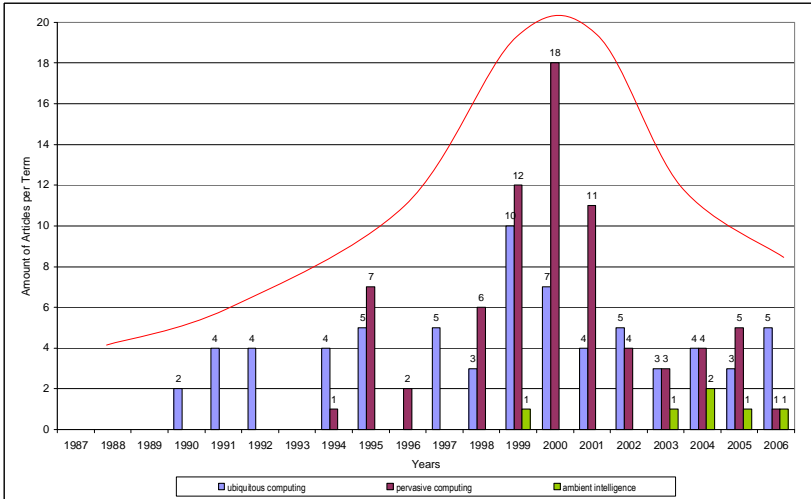

Figure 1: Amount of articles in unit of analysis referencing the researched terms in the years 1990-2006

In the past 17 years pervasive computing has been used in fifty percent of the researched newspaper articles, whereas approximately forty six percent used ubiquitous computing and only about four percent wrote about ambient intelligence (Table 1 and Figure 1). Given that ubiquitous computing was the first of the three terms, and given that this term has been in use seven years longer than pervasive computing the question does arise why pervasive computing became more popular and why ambient intelligence remained unpopular.

3.1 Qualitative Analysis

3.3.1 Introduction

Within the 148 articles (constituting the unit of analysis) the newspaper authors ascribe certain meaning to the three terms ubiquitous computing, pervasive computing and ambient intelligence.

The terms have been reviewed for the following attributes:

Attributes	Attribute type
1. Having access <i>anywhere at any time</i> ; 2. Using the technology for <i>business or work</i> ; 3. Enabling the technology at <i>home</i> and for <i>leisure</i> ;	location: "where"
4. Deploying the technology through <i>networks</i> ; 5. Applying <i>sensor</i> technology; and 6. Making the environment <i>intelligent</i> and <i>smart</i> .	means: "how"

Two main areas emerge from these attributes: the first three attributes (numbers 1 to 3) touch on the location and answer the question "where". The three subsequent attributes (numbers 4 to 6) cover the means for such technology and answer the question "how". Each researched term (ubiquitous computing, pervasive computing and ambient intelligence) was interfaced with each of these six attributes.

3.1.2 Ubiquitous Computing

The term ubiquitous computing first appeared in the researched newspapers in 1987. Not in the meaning envisioned by Mark Weiser - and thus not included in the researched articles, but still noteworthy for its early appearance - it was used by Steve Jobs upon decision to build sophisticated, but inexpensive, computers for the higher education market, giving university students and researchers easy access to computing power. Jobs referred to the "Apple II" and noted that it was "a ubiquitous computing resource that is powerful, reliable and flexible enough to be used everywhere on campus" [own emphasis]. [16] The use of the term in this context obviously relates to desktop computers and not to the wireless communication researched in this paper. But the statement does pick up the concept of computers being ubiquitous and accessible from anywhere.

During 1990 and 1994 the term ubiquitous computing was primarily related to miniaturising office equipment. The challenge was to design technology that would promote organizational cohesion and that would discover effective processes for fitting technology into the pattern of working life. [17] To such extent, computing would become ubiquitous

by computerising life as it is [18] with computers that got smaller and smaller [19], and in the end did not look like computers anymore and were everywhere [20]. It was implied that computer power would be on tap like water or electricity. [17]

As of 1994 the notion of extending the dispersion of microchips buried throughout the support stems of terminals and small devices in walls and ceilings of primarily enterprises [21] extended slightly to the application of computers into life style items [22]. But the concept of ubiquitous computing was not only moving the information era towards turning virtually everything into a personal computer [23] and embedding computers beyond the office also throughout the home [24] and for leisure [25]. As of the mid nineties the term was also used to address mobile computing [26], especially in Europe where Nokia sold Internet enabled handhelds [27]. The concept of having access to information from any location with any (handheld) device carried on into the new millennium.

3.1.3 Pervasive Computing

As compared to the term ubiquitous computing, the term pervasive computing first appeared four years later in 1994 in the researched newspapers. Novell's Chairman Robert J. Frankenberg outlined his strategic direction for Novell by connecting people to people and to information. [28] Within the next one and a half years pervasive computing was used exclusively in the researched articles in connection with Novell's business enabling people to connect any place at any time [29], i.e., to deliver "information to computer users wherever and whenever they might need it" [30].

After the headline interest in pervasive computing declined, it resurfaced in 1998 in IBM's post-PC [31] world, meaning that computers were everywhere, not just on one's desktop [32]. Whereas one year later Sun Microsystems' pervasive computing philosophy was that "the computer is the network" [33], IBM was more focussed on the device and the appliances [34], such as handhelds, wireless computers, and mobile phones. Around the turn of the millennium the interest in pervasive computing grew exponentially. Not surprisingly pervasive computing was declared a buzz word [35] during the peak of the dot.com bubble. The objective during that time was that

(consumer) electronic devices had to be constantly connected to the Internet [36] and that one had to always be in touch [37]. The technology hype fostered examples of use from grocery stores [38] over smart fabrics [39] and wearable computers [40] to biomechatronics and medical telematics [41].

From the year 2001 onwards the use of the term pervasive computing dropped radically. Until end of 2006 the term was used in the previous manner and it included sensor technology [42] but altogether less extensively.

3.1.4 Ambient Intelligence

In 1999 the term ambient intelligence appeared for the first time and – until 2003 – the only time in the researched newspapers. The director of Philips elaborated about the digital home and how ambient intelligence could with speech and gesture provide anything, anytime and anywhere. [43] The use of the term remained wondrously but steadily low in the first years of the new millennium. Ambient intelligence was used, for instance, to describe technology that disappears into its surroundings [44] as well as a bridge between the real and digital world [45].

3.1.5 Evaluation

Since IBM supported and used the term pervasive computing one could be inclined to assume that the popularity of the term has something to do with the influence of the worldwide largest IT company. Whereas the influence and importance of the sponsoring entity will certainly have fostered the strong status of the term pervasive computing it cannot have been the only factor. For Philips is also a well known and leading international company in the electronics industry. But with six articles since 1999 Philips' ambient intelligence did not at all have such fulminant adoption – at least not in the researched newspapers. So there must be other factors to be considered.

First, one can derive from the newspaper articles that both terms ubiquitous computing and pervasive computing have been used in the contexts of mobile technology such as mobile phones, handhelds and wireless computers. According to the International Telecommuni-

cations Union (ITU) [46], mobile phone subscriptions in the developed countries have increased from 5.2 mobile phones per 100 inhabitants in 1994 to 76.8 mobile phones per 100 inhabitants in 2004. One can thus infer that the association of the increasing proliferation of mobile phones with which one is connected anywhere for both work and leisure supported the popularity of the terms ubiquitous computing and pervasive computing.

Second, the flow of the chart in Figure 1 shows that the term ambient intelligence with its first newspaper appearance in 1999 missed the wave of the dot.com bubble. The economic and personal setbacks after the dot.com bubble burst at the beginning of the millennium left more than a bitter aftertaste which made it difficult for the term to gain ground. Whereas the interest in the terms ubiquitous computing and pervasive computing declined, here it is argued that there was little chance for the term ambient intelligence to become popular. Public and newspapers lost interest altogether.

Third, one might speculate [47], there have been political and force majeure influences during the introduction of the ambient intelligence hindering the proliferation of concept:

1. The term was not created by the authorities but by a (private) entity, namely Philips. This might have lead to resistance by the Brussels authorities to use and push such term;
2. Although there was effort to associate the (private) term publicly by introducing it through University authorities, a strong association with Philips as “creator” of the term ambient intelligence might have remained; and
3. The terrorist attacks of September 11, 2001 might have throttled the use of this ambient intelligence technology. As ambient intelligence is an open concept with open standards and large communications potential, it did not fit into the new and strict security standards introduced after 9/11.

3.2 Quantitative Analysis

3.2.1 Introduction

Figure 2 shows all attributes ("anywhere, any time", "home, leisure", "business, work", "network", "sensor" and "intelligent, smart") for all

researched terms (ubiquitous computing, pervasive computing and ambient intelligence) in the researched newspapers over the past 17 years.

Within the three attributes relating to the means (“how”), networking appears in 64 newspaper articles and is the most related “how” attribute whereas sensor technology only accounts for about half as many references (35) and intelligence is attributed in 45 cases. Within the three attributes relating to location (“where”), the access through ubiquitous computing, pervasive computing or ambient intelligence shall in the majority of cases be anywhere at any time (58), directly followed by the desire to deploy such technology from home or for leisure (53). The office and the relation to work are referenced 41 times within the unit of analysis. The reason for this decline being that the line separating work form leisure is more and more blurred [25]. Working space in the modern office is not confined to an office building anymore, but increasingly takes place, for instance, at home, at airports or in hotel lobbies. [48]

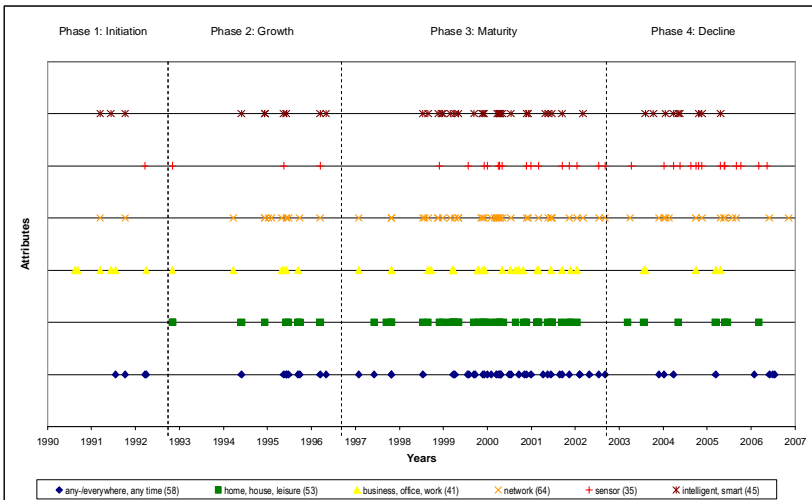

Figure 2: Attributes per year for all three researched terms (in parentheses the aggregate amount per attribute).

In order to discuss the quantitative differences in the attributes, the following Table 2 shows the nominal counts and percentages for each attribute:

	Attribute	ubiquitous computing		pervasive computing		ambient intelligence		Total	
		no-minal	%	no-minal	%	no-minal	%	no-minal	%
location	Anywhere, anytime	31	53.4%	26	44.8%	1	1.7%	58	100%
	Home, leisure	19	35.8%	32	60.4%	2	3.8%	53	100%
	Business, work	26	63.4%	14	34.1%	1	2.4%	41	100%
means	Networks	23	35.9%	39	60.9%	2	3.1%	64	100%
	Sensor	19	54.3%	13	37.1%	3	8.6%	35	100%
	Intelligent, smart	19	42.2%	22	48.9%	4	8.9%	45	100%
	Total	137	46.3%	146	49.3%	13	4.4%	296	100%

Table 2: Overview attribute quantities (nominal term count and percentages of total; in italics the most relevant figures by quantity).

3.2.2 Ubiquitous Computing

As Table 2 shows, within the first three attributes relating to location (“where”) the access anywhere at any time (31 referenced articles) is nominally the most important. It is followed by access to information at work (26 referenced articles) and finally from home (19 referenced articles). By contrast, the attributes relating to means (“how”) show 23 references for network and 19 articles each for sensor and intelligent technology.

As compared to the other terms the attribute work (63.4%) is still the most relevant, however, followed by sensor which is not a location (“where”) attribute but a means (“how”) attribute.

With an overall nominal count of 137 the term ubiquitous computing is on average slightly below one publication per 148 newspaper articles.

3.2.3 Pervasive Computing

Noticeable is the great amount of combinations relating to the deployment of technology at home and for leisure (26 and 32 references) and especially the decline in business and the work (only 14 articles) as compared to the corresponding attribute describing ubiquitous computing. Within the attributes relating to means ("how") networking stands out (39 references), whereas sensor technology (13 references) decreased substantially compared to the respective attribute in ubiquitous computing.

In this term concept, the attribute networks (60.9%) is the most important as compared to the overall attribute appearances. It is followed by home (60.4%) and a second means ("how") attribute intelligent (48.9%).

On average, the term pervasive computing is practically present in every researched newspaper article (146 nominal counts on 148 articles).

3.2.4 Ambient Intelligence

Because there were only 6 references by the end of 2006 for the term ambient intelligence a quantitative evaluation is quite difficult. Looking at the distribution of the attributes, those relating to the means attributes ("how"), namely network (2 references), sensor (3 references) and intelligent (4 references) stand out to be more in the focus of interest than the location attributes ("where") home (2 references) and anywhere, work (each with one reference).

Relative to the attributes of the other two terms, the most important attributes for ambient intelligence are intelligent (8.9%) as well as sensor (8.6%). Third in row is the attribute home (3.8%).

The term ambient intelligence is on average only mentioned in every 8th newspaper article.

3.2.5 Evaluation

Ambient intelligence is the most difficult term to judge because of the relatively few occurrences of the concept. From the missing presence

in the researched newspapers one can infer that ambient intelligence is not a very popular term.

First, the term ambient intelligence – being a European term – was not used so scarcely because more US/Canadian newspapers were researched in the unit of analysis. As Table 1 indicates, from the overall six references to ambient intelligence three were in the UK and three in North America, i.e., evenly distributed. What strikes is not only the limited use of ambient intelligence from 1999 through 2006, but the continuing use of the other two terms ubiquitous computing and pervasive computing even after introduction of the ambient intelligence in 1999.

Second, comparing the results of the individual attribute outputs of the researched terms among each other shows that there is a shift in importance from the location attributes (“where”) to the means attributes (“how”) (Table 2): Overall the term ubiquitous computing has more references in the location attributes (76 location / 61 means) than the other two terms. The term pervasive computing has an almost balanced focus between both attribute types (72 location / 74 means). And lastly, ambient intelligence shows the shift towards the means attributes (4 location / 9 means). This evaluation is also reflected at the single attribute level: ubiquitous computing refers the most to the attribute anywhere at anytime (“where”), whereas there is a shift in pervasive computing to networking and lastly to intelligence in ambient intelligence (“how”).

Third, as compared to these differences at the individual attribute level, the aggregation per attribute over the past 17 years does not show significant differences. The patterns in Figure 2 for each attribute are very similar and only reveal marginal variances. It is important to note that the attributes relating to ambient intelligence have only contributed minimally to such patterns. Only 4.4% of the attributes are related to ambient intelligence (Table 2) and they only contribute as of 1999 (Figure 1). Likewise the attributes from 1990 to 1993 only pertain to ubiquitous computing as the term pervasive computing only appeared in 1994. Therefore, all together one can state that the constant patterns of appearance of the attributes in Figure 2 are given by ubiquitous computing and pervasive computing.

4 Conclusion

News media have become the modern day forum for the representation of public opinion. [49] It has not been the goal of this research to analyse whether the reporting in the newspapers is accurate and from what evidence it was collected. The goal of this research is to show the diffusion of these new concepts of ubiquitous computing, pervasive computing and ambient intelligence to the public.

First, it is concluded that whereas there are variances in the use of the attributes pertaining to each researched concept – ubiquitous computing relates more to work environment, pervasive computing relates more to networks, and ambient intelligence relates more to smart/sensor – each of the three terms is described by all six attributes. Thus scientifically there might be a difference between the terms ubiquitous computing, pervasive computing and ambient intelligence. By and large, however, such distinction proves unimportant in the daily use of the terms.

Second, because the concept ambient intelligence was only coined in 1998, it seems obvious that Europeans would have used the established terms ubiquitous computing and pervasive computing before creating its own. Interestingly, however, in the eight years the term ambient intelligence has been in use, the newspapers did not change their language. Nor did the UK newspapers abandon the North American terms ubiquitous computing or pervasive computing. On the contrary, the amount of newspaper articles with the established terms ubiquitous computing and pervasive computing grew and it seems as though the term ambient intelligence was – to the extent it has been used – only added to the repertoire.

Third, the introduction of a new concept such as ambient intelligence needs not only be accompanied by means that are or will be widely popular (such as a mobile phone), but the general public also needs to be able to relate to such means. Both the qualitative as well as the quantitative analysis have shown that the public makes associations to attributes like home, work and networks. But there is much less reference on dissemination of intelligent sensor technology (as promoted by the concept of ambient intelligence). A new concept should

1. not already be occupied by attributes used in other terms, and
2. it should be associated to a technology that the general public relates to.

This means that the concept of ambient intelligence should especially not be used for attributes anywhere, home, work, and networks as these are in public well established with the concepts of ubiquitous computing and pervasive computing. It is questionable whether the concept of ambient intelligence could succeed relating to the attributes sensor and intelligence as these are also – however clearly less – used by the other two concepts. If it is to succeed as term, here it is tentatively argued that such concept for ambient intelligence would need to be associated with a popular product or service that is understood by the public (like, for instance, the diffusion of mobiles by Nokia in Europe).

References

- [1] M. Weiser: Some Computer Science Issues in Ubiquitous Computing, ACM SIGMOBILE Mobile Computing and Communications Review, Vol. 3, Issue 3, pp. 12-20 (July 1999).
- [2] M. Weiser: The World is not a Desktop, ACM Interactions, Vol. 1, Issue 1, pp. 7-8 (January 1994).
- [3] U. Hansmann, et al.: Pervasive Computing, Springer, 2nd ed., pp. 1 & 14 (2003).
- [4] IST Advisory Group: Information Society Technologies Advisory Group: Orientations for Workprogramme 2000 and Beyond, pp. 3-4 (17. September 1999).
- [5] F. Mattern: "Die Technische Basis für das Internet der Dinge", Institut für Pervasive Computing, ETH Zürich, p. 3.
- [6] IST Advisory Group Report: "Ambient Intelligence: from vision to reality. For participation – in society & business", Final Report, p. 12 (2003).
- [7] L. Gorman and D. McLean: Media and Society in the Twentieth Century. A Historical Introduction, Blackwell Publishing, pp. 14, 160-165, 203 (2003).

- [8] P. Manning: *News and News Sources. A Critical Introduction*. Sage Publications, p. 13 (2001).
- [9] L. Grossberg, E. Wartella, D. Whitney and J. MacGregor Wise: *Media Making – Mass Media in a Popular Culture*, 2nd ed., Sage Publications, p. 379 (2006).
- [10] B. Gunter: *The Quantitative Research Process*, in K. Jensen (ed.): *A Handbook of Media and Communication Research. Qualitative and Quantitative Methodologies*, Routledge, pp. 209-234 (2002).
- [11] <http://global.factiva.com> (license required, last accessed 29. September 2007).
- [12] <http://www.lexisnexis.com> (license required, last accessed 29. September 2007).
- [13] S. Schultz Huxman and M. Allen: *Scientists and Storytellers: The Imperative of Pairing Qualitative and Quantitative Approaches in Communication Research*, in: S. Hartin Iorio: *Qualitative Research in Journalism: Taking it to the Streets*, Lawrence Erlbaum Associates, pp. 175-192 (2005).
- [14] K. Jensen: *The Complementarity of Qualitative and Quantitative Methodologies in Media and Communication Research*, in: K. Jensen: *A Handbook of Media and Communication Research. Qualitative and Quantitative Methodologies*, Routledge, p. 272 (2002).
- [15] K. Jensen: *The Qualitative Research Process*, in: K. Jensen (ed.): *A Handbook of Media and Communication Research. Qualitative and Quantitative Methodologies*, Routledge, pp. 243-244, 246 (2002).
- [16] M. Potts: *Computer Industry Wary Of Jobs-Perot Alliance*, *The Washington Post*, p. H2 (February 8, 1987).
- [17] A. Cane: *Research Park Takes Unique Look at Working Life in 21st Century*, *Financial Times* (London), sec. 1, Special Report Computers, p. 18 (June 10, 1991).
- [18] Y. Kreider: *Technology*, *Wall Street Journal*, (Eastern edition), p. B.1 (August 17, 1990).
- [19] ____: *The Latest in Computer Couture*, *N.Y. Times*, sec. D, p. 1, col. 3 (March 19, 1992).

- [20] T. Durhan: Computer: Mightier than the Mouse? - Pen-based Computers could Rival Keyboards, The Guardian (London), (July 18, 1991).
- [21] J. Achenbach: Wire Me Up, Scotty - We have Seen the Future, but We Still Can't Tell You What it Means, The Washington Post, p. W10 (May 29, 1994).
- [22] L. Fisher: The Executive Computer; The Industry Cognoscenti Take a Stab at the Vision Thing, The New York Times, sec. 3, p. 8 (December 11, 1994).
- [23] J. Markoff: Information Technology, And Now, Computerized Sensibility, The New York Times, sec. D, p. 6, col. 1 (May 15, 1995).
- [24] P. Taylor: A New Era of Voice Computing: The Wide Use of Computers Controlled by Speech, Rather than Keyboards and Mice, could Eventually have Dramatic Implications in the Office and Home, Financial Times (London), sec. FT IT, p. 1 (June 4, 1997).
- [25] A. Lang: Possible Dreams, The Financial Post, Special Report Computers, sec. 4, p. 52, (October 25, 1997).
- [26] D. MacLeod: Higher: Hero for College Hopefuls? Whether You're Seeking Courses or Verifying Research, a New Catch-all Website Launched Today May Help, The Guardian (London), sec. Education, p. 15 (March 6, 2001).
- [27] J. Gilroy: Ask the Computer Guy, The Washington Post, p. F18 (November 25, 1996).
- [28] J. Schofield: Analysis: Can Novell Make the Connections?, The Guardian (London), p. T8 (September 22, 1994).
- [29] T. Jackson: Media Futures: A Nest to House 1bn Computers, Financial Times (London), p. 15 (September 25, 1995).
- [30] L. Kehoe: A Pot-shot at the 'Microsofties' - Like Many Others in the Software Industry, Novell, the Leading Supplier of Local Area Network Software, is Eager to Participate in the Emerging Market for Online Electronic Commerce, Financial Times (London), sec. FT IT, p. II. (June 7, 1995).

- [31] S. Lohr and J. Markoff: Computing's Next Wave Is Nearly at Hand; Imagining the Future in a Post-PC World, The New York Times, sec. C, p. 1, col. 2 (December 28, 1998).
- [32] M. Nusca: Haute Couture: Wearable Computers: Post-PC fashions, National Post (Canada), Special Report IT, p. C13 (April 19, 1999).
- [33] M. Dempsey: Setting the Networks Free: Developer's Viewpoint: John Gage of SUN Microsystems: The Unhindered Flow of Digital Data is the Vision which Motivates one of Silicon Valley's Leading and Most Outspoken Companies, Financial Times (London), p. 14 (April 7, 1999).
- [34] E.g., R. Samuelson: Have PCs Peaked? The Washington Post, sec. OP-ED, p. A27 (April 1, 1999).
- [35] L. Guernsey: Storing Your Life in a Virtual Desktop; Web-Based Storage and Software Reinvents an Old Idea, the Network Computer, The New York Times, sec. G, p. 1, col. 5 (November 25, 1999).
- [36] J. Schofield: Web-ready Kitchen Moves a Step Closer to Reality, The Guardian (London), p. 28 (December 2, 1999).
- [37] D. Ignatius: Tools for the 2000s, The Washington Post, sec. OP-ED, p. A33 (December 8, 1999).
- [38] I. Austen: Wireless Technology for Offline Shoppers, The New York Times, sec. G, p. 10, col. 1 (December 7, 2000).
- [39] T. Radford: Move Over Bossy Boots: the Handbag that Speaks, The Guardian (London), p. 6 (October 21, 2004).
- [40] L. Walker: Growing Up, Growing Old In the Digital Age, The Washington Post, p. G01 (May 16, 2001).
- [41] J. Thackara: Second sight: We Risk Losing Our Heads if We Run Headlong into Pervasive Computing, The Guardian (London), p. 9 (July 13, 2000).
- [42] J. Markoff: Early Look at Research Project to Re-engineer the Internet, The New York Times, sec. C, p. 2, col. 1 (August 29, 2005).
- [43] S. Jones: Digital Era 'Will Make Prime-time Television Obsolete', Financial Times (London), p. 10 (September 14, 1999).

- [44] S. Agrell: The Underwear You Want Rescue Workers to See, National Post (Canada), p. A1 (October 11, 2003).
- [45] J. Scanlon: A Design Epiphany: Keep It Simple, The New York Times, sec. G, p. 5, col. 1 (May 20, 2004).
- [46] <http://www.itu.int/ITU-D/ict/statistics/ict/index.html> (last accessed 26. August 2007).
- [47] Telephone interview with a former ISTAG member of the European Union's Framework Programme 6, conducted on 23. November 2006.
- [48] D. Paul: There'll Be No Summer Breaks for 'Vacation Office' Workers, Wall Street Journal, p. B12 (June 27, 1997).
- [49] J. Lewis and K. Wahl-Jorgensen: Active Citizen or Couch Potato? Journalism and Public Opinion, in A. Stuart (ed.): Journalism: Critical Issues, Open University Press, pp. 98-108 (2005).

TITLER I PH.D.SERIEN:

– a Field Study of the Rise and Fall of a Bottom-Up Process

2004

1. Martin Grieger
Internet-based Electronic Marketplaces and Supply Chain Management
2. Thomas Basbøll
*LIKENESS
A Philosophical Investigation*
3. Morten Knudsen
*Beslutningens vaklen
En systemteoretisk analyse af moderniseringen af et amtskommunalt sundhedsvæsen 1980-2000*
4. Lars Bo Jeppesen
*Organizing Consumer Innovation
A product development strategy that is based on online communities and allows some firms to benefit from a distributed process of innovation by consumers*
5. Barbara Dragsted
*SEGMENTATION IN TRANSLATION AND TRANSLATION MEMORY SYSTEMS
An empirical investigation of cognitive segmentation and effects of integrating a TM system into the translation process*
6. Jeanet Hardis
*Sociale partnerskaber
Et socialkonstruktivistisk casestudie af partnerskabsaktørers virkelighedsopfattelse mellem identitet og legitimitet*
7. Henriette Hallberg Thygesen
System Dynamics in Action
8. Carsten Mejer Plath
Strategisk Økonomistyring
9. Annemette Kjærgaard
Knowledge Management as Internal Corporate Venturing
10. Knut Arne Hovdal
*De professionelle i endring
Norsk ph.d., ej til salg gennem Samfundslitteratur*
11. Søren Jeppesen
*Environmental Practices and Greening Strategies in Small Manufacturing Enterprises in South Africa
– A Critical Realist Approach*
12. Lars Frode Frederiksen
*Industriel forskningsledelse
– på sporet af mønstre og samarbejde i danske forskningsintensive virksomheder*
13. Martin Jes Iversen
*The Governance of GN Great Nordic
– in an age of strategic and structural transitions 1939-1988*
14. Lars Pynt Andersen
*The Rhetorical Strategies of Danish TV Advertising
A study of the first fifteen years with special emphasis on genre and irony*
15. Jakob Rasmussen
Business Perspectives on E-learning
16. Sof Thrane
*The Social and Economic Dynamics of Networks
– a Weberian Analysis of Three Formalised Horizontal Networks*
17. Lene Nielsen
Engaging Personas and Narrative Scenarios – a study on how a user-centered approach influenced the perception of the design process in the e-business group at AstraZeneca
18. S.J Valstad
*Organisationsidentitet
Norsk ph.d., ej til salg gennem Samfundslitteratur*

19. Thomas Lyse Hansen
Six Essays on Pricing and Weather risk in Energy Markets
20. Sabine Madsen
Emerging Methods – An Interpretive Study of ISD Methods in Practice
21. Evis Sinani
The Impact of Foreign Direct Investment on Efficiency, Productivity Growth and Trade: An Empirical Investigation
22. Bent Meier Sørensen
Making Events Work Or, How to Multiply Your Crisis
23. Pernille Schnoor
*Brand Ethos
Om troværdige brand- og virksomhedsidentiteter i et retorisk og diskursteoretisk perspektiv*
24. Sidsel Fabech
*Von welchem Österreich ist hier die Rede?
Diskursive forhandlinger og magtkampe mellem rivaliserende nationale identitetskonstruktioner i østrigske pressediskurser*
25. Klavs Odgaard Christensen
*Sprogpolitik og identitetsdannelse i flersprogede forbundsstater
Et komparativt studie af Schweiz og Canada*
26. Dana B. Minbaeva
Human Resource Practices and Knowledge Transfer in Multinational Corporations
27. Holger Højlund
*Markedets politiske fornuft
Et studie af velfærdens organisering i perioden 1990-2003*
28. Christine Mølgaard Frandsen
*A.s erfaring
Om mellemværendets praktik i en transformation af mennesket og subjektiviteten*
29. Sine Nørholm Just
The Constitution of Meaning – A Meaningful Constitution? Legitimacy, identity, and public opinion in the debate on the future of Europe
- 2005**
1. Claus J. Varnes
Managing product innovation through rules – The role of formal and structured methods in product development
2. Helle Hedegaard Hein
Mellem konflikt og konsensus – Dialogudvikling på hospitalsklinikker
3. Axel Rosenhø
Customer Value Driven Product Innovation – A Study of Market Learning in New Product Development
4. Søren Buhl Pedersen
*Making space
An outline of place branding*
5. Camilla Funck Ellehave
*Differences that Matter
An analysis of practices of gender and organizing in contemporary work-places*
6. Rigmor Madeleine Lond
Styring af kommunale forvaltninger
7. Mette Aagaard Andreassen
Supply Chain versus Supply Chain Benchmarking as a Means to Managing Supply Chains
8. Caroline Aggestam-Pontoppidan
*From an idea to a standard
The UN and the global governance of accountants' competence*
9. Norsk ph.d.
10. Vivienne Heng Ker-ni
An Experimental Field Study on the

- Effectiveness of Grocer Media Advertising*
Measuring Ad Recall and Recognition, Purchase Intentions and Short-Term Sales
11. Allan Mortensen
Essays on the Pricing of Corporate Bonds and Credit Derivatives
12. Remo Stefano Chiari
Figure che fanno conoscere
Itinerario sull'idea del valore cognitivo e espressivo della metafora e di altri tropi da Aristotele e da Vico fino al cognitivismo contemporaneo
13. Anders Mclquham-Schmidt
Strategic Planning and Corporate Performance
An integrative research review and a meta-analysis of the strategic planning and corporate performance literature from 1956 to 2003
14. Jens Geersbro
The TDF – PMI Case
Making Sense of the Dynamics of Business Relationships and Networks
15. Mette Andersen
Corporate Social Responsibility in Global Supply Chains
Understanding the uniqueness of firm behaviour
16. Eva Boxenbaum
Institutional Genesis: Micro – Dynamic Foundations of Institutional Change
17. Peter Lund-Thomsen
Capacity Development, Environmental Justice NGOs, and Governance: The Case of South Africa
18. Signe Jarlov
Konstruktioner af offentlig ledelse
19. Lars Stæhr Jensen
Vocabulary Knowledge and Listening Comprehension in English as a Foreign Language
- An empirical study employing data elicited from Danish EFL learners*
20. Christian Nielsen
Essays on Business Reporting
Production and consumption of strategic information in the market for information
21. Marianne Thejls Fischer
Egos and Ethics of Management Consultants
22. Annie Bekke Kjær
Performance management i Process-innovation
– belyst i et social-konstruktivistisk perspektiv
23. Suzanne Dee Pedersen
GENTAGELSENS METAMORFOSE
Om organisering af den kreative gøren i den kunstneriske arbejdspraksis
24. Benedikte Dorte Rosenbrink
Revenue Management
Økonomiske, konkurrencemæssige & organisatoriske konsekvenser
25. Thomas Riise Johansen
Written Accounts and Verbal Accounts
The Danish Case of Accounting and Accountability to Employees
26. Ann Fogelgren-Pedersen
The Mobile Internet: Pioneering Users' Adoption Decisions
27. Birgitte Rasmussen
Ledelse i fællesskab – de tillidsvalgte fornyende rolle
28. Gitte Thit Nielsen
Remerger
– skabende ledelseskrafter i fusion og opkøb
29. Carmine Gioia
A MICROECONOMETRIC ANALYSIS OF MERGERS AND ACQUISITIONS

30. Ole Hinz
Den effektive forandringsleder: pilot, pædagog eller politiker?
Et studie i arbejdsleders meningstilskrivninger i forbindelse med vellykket gennemførelse af ledelsesinitierede forandringsprojekter
31. Kjell-Åge Gotvassli
Et praksisbasert perspektiv på dynamiske læringsnettverk i toppidretten
Norsk ph.d., ej til salg gennem Samfundslitteratur
32. Henriette Langstrup Nielsen
Linking Healthcare
An inquiry into the changing performances of web-based technology for asthma monitoring
33. Karin Tweddell Levinson
Virtual Uddannelsespraksis
Master i IKT og Læring – et casestudie i hvordan proaktiv proceshåndtering kan forbedre praksis i virtuelle læringsmiljøer
34. Anika Liversage
Finding a Path
Labour Market Life Stories of Immigrant Professionals
35. Kasper Elmquist Jørgensen
Studier i samspillet mellem stat og erhvervsliv i Danmark under 1. verdenskrig
36. Finn Janning
A DIFFERENT STORY
Seduction, Conquest and Discovery
37. Patricia Ann Plackett
Strategic Management of the Radical Innovation Process
Leveraging Social Capital for Market Uncertainty Management
- 2006
1. Christian Vintergaard
Early Phases of Corporate Venturing
2. Niels Rom-Poulsen
Essays in Computational Finance
3. Tina Brandt Husman
Organisational Capabilities, Competitive Advantage & Project-Based Organisations
The Case of Advertising and Creative Good Production
4. Mette Rosenkrands Johansen
Practice at the top
– how top managers mobilise and use non-financial performance measures
5. Eva Parum
Corporate governance som strategisk kommunikations- og ledelsesværktøj
6. Susan Aagaard Petersen
Culture's Influence on Performance Management: The Case of a Danish Company in China
7. Thomas Nicolai Pedersen
The Discursive Constitution of Organizational Governance – Between unity and differentiation
The Case of the governance of environmental risks by World Bank environmental staff
8. Cynthia Selin
Volatile Visions: Transactions in Anticipatory Knowledge
9. Jesper Banghøj
Financial Accounting Information and Compensation in Danish Companies
10. Mikkel Lucas Overby
Strategic Alliances in Emerging High-Tech Markets: What's the Difference and does it Matter?
11. Tine Aage
External Information Acquisition of Industrial Districts and the Impact of Different Knowledge Creation Dimensions

- A case study of the Fashion and Design Branch of the Industrial District of Montebelluna, NE Italy*
12. Mikkel Flyverbom
*Making the Global Information Society Governable
On the Governmentality of Multi-Stakeholder Networks*
 13. Anette Grønning
*Personen bag
Tilstedevær i e-mail som interaktionsform mellem kunde og medarbejder i dansk forsikringskontekst*
 14. Jørn Helder
*One Company – One Language?
The NN-case*
 15. Lars Bjerregaard Mikkelsen
*Differing perceptions of customer value
Development and application of a tool for mapping perceptions of customer value at both ends of customer-supplier dyads in industrial markets*
 16. Lise Granerud
*Exploring Learning
Technological learning within small manufacturers in South Africa*
 17. Esben Rahbek Pedersen
*Between Hopes and Realities:
Reflections on the Promises and Practices of Corporate Social Responsibility (CSR)*
 18. Ramona Samson
*The Cultural Integration Model and European Transformation.
The Case of Romania*
- 2007**
1. Jakob Vestergaard
*Discipline in The Global Economy
Panopticism and the Post-Washington Consensus*
 2. Heidi Lund Hansen
*Spaces for learning and working
A qualitative study of change of work, management, vehicles of power and social practices in open offices*
 3. Sudhanshu Rai
*Exploring the internal dynamics of software development teams during user analysis
A tension enabled Institutionalization Model; "Where process becomes the objective"*
 4. Norsk ph.d.
Ej til salg gennem Samfundslitteratur
 5. Serden Ozcan
*EXPLORING HETEROGENEITY IN ORGANIZATIONAL ACTIONS AND OUTCOMES
A Behavioural Perspective*
 6. Kim Sundtoft Hald
*Inter-organizational Performance Measurement and Management in Action
– An Ethnography on the Construction of Management, Identity and Relationships*
 7. Tobias Lindeberg
*Evaluative Technologies
Quality and the Multiplicity of Performance*
 8. Merete Wedell-Wedellsborg
*Den globale soldat
Identitetsdannelse og identitetsledelse i multinationale militære organisationer*
 9. Lars Frederiksen
*Open Innovation Business Models
Innovation in firm-hosted online user communities and inter-firm project ventures in the music industry
– A collection of essays*
 10. Jonas Gabrielsen
Retorisk toposlære – fra statisk 'sted' til persuasiv aktivitet

11. Christian Moldt-Jørgensen
Fra meningsløs til meningsfuld evaluering.
Anvendelsen af studentertilfredsheds-målinger på de korte og mellemlange videregående uddannelser set fra et psykodynamisk systemperspektiv
12. Ping Gao
Extending the application of actor-network theory
Cases of innovation in the telecommunications industry
13. Peter Mejlby
Frihed og fængsel, en del af den samme drøm?
Et phronetisk baseret casestudie af frigørelsens og kontrollens sam-eksistens i værdibaseret ledelse!
14. Kristina Birch
Statistical Modelling in Marketing
15. Signe Poulsen
Sense and sensibility:
The language of emotional appeals in insurance marketing
16. Anders Bjerre Trolle
Essays on derivatives pricing and dynamic asset allocation
17. Peter Feldhütter
Empirical Studies of Bond and Credit Markets
18. Jens Henrik Eggert Christensen
Default and Recovery Risk Modeling and Estimation
19. Maria Theresa Larsen
Academic Enterprise: A New Mission for Universities or a Contradiction in Terms?
Four papers on the long-term implications of increasing industry involvement and commercialization in academia
20. Morten Wellendorf
Postimplementering af teknologi i den offentlige forvaltning
Analysér af en organisations kontinuerlige arbejde med informations-teknologi
21. Ekaterina Mhaanna
Concept Relations for Terminological Process Analysis
22. Stefan Ring Thorbjørnsen
Forsvaret i forandring
Et studie i officerers kapabiliteter under påvirkning af omverdenens forandringspres mod øget styring og læring
23. Christa Breum Amhøj
Det selvskabte medlemskab om managementstaten, dens styringsteknologier og indbyggere
24. Karoline Bromose
Between Technological Turbulence and Operational Stability
– An empirical case study of corporate venturing in TDC
25. Susanne Justesen
Navigating the Paradoxes of Diversity in Innovation Practice
– A Longitudinal study of six very different innovation processes – in practice
26. Luise Noring Henler
Conceptualising successful supply chain partnerships
– Viewing supply chain partnerships from an organisational culture perspective
27. Mark Mau
Kampen om telefonen
Det danske telefonvæsen under den tyske besættelse 1940-45
28. Jakob Halskov
The semiautomatic expansion of existing terminological ontologies using knowledge patterns discovered

- on the WWW – an implementation and evaluation*
29. Gergana Koleva
European Policy Instruments Beyond Networks and Structure: The Innovative Medicines Initiative
 30. Christian Geisler Asmussen
Global Strategy and International Diversity: A Double-Edged Sword?
 31. Christina Holm-Petersen
*Stolthed og fordom
Kultur- og identitetsarbejde ved skabelsen af en ny sengeafdeling gennem fusion*
 32. Hans Peter Olsen
*Hybrid Governance of Standardized States
Causes and Contours of the Global Regulation of Government Auditing*
 33. Lars Bøge Sørensen
Risk Management in the Supply Chain
 34. Peter Aagaard
*Det unikkes dynamikker
De institutionelle mulighedsbetingelser bag den individuelle udforskning i professionelt og frivilligt arbejde*
 35. Yun Mi Antorini
*Brand Community Innovation
An Intrinsic Case Study of the Adult Fans of LEGO Community*
 36. Joachim Lynggaard Boll
*Labor Related Corporate Social Performance in Denmark
Organizational and Institutional Perspectives*
- 2008**
1. Frederik Christian Vinten
Essays on Private Equity
 2. Jesper Clement
Visual Influence of Packaging Design on In-Store Buying Decisions
 3. Marius Brostrøm Kousgaard
*Tid til kvalitetsmåling?
– Studier af indrulleringsprocesser i forbindelse med introduktionen af kliniske kvalitetsdatabaser i speciallægepraksissektoren*
 4. Irene Skovgaard Smith
*Management Consulting in Action
Value creation and ambiguity in client-consultant relations*
 5. Anders Rom
*Management accounting and integrated information systems
How to exploit the potential for management accounting of information technology*
 6. Marina Candi
Aesthetic Design as an Element of Service Innovation in New Technology-based Firms
 7. Morten Schnack
*Teknologi og tværfaglighed
– en analyse af diskussionen omkring indførelse af EPJ på en hospitalsafdeling*
 8. Helene Balslev Clausen
Juntos pero no revueltos – un estudio sobre emigrantes norteamericanos en un pueblo mexicano
 9. Lise Justesen
*Kunsten at skrive revisionsrapporter.
En beretning om forvaltningsrevisions beretninger*
 10. Michael E. Hansen
The politics of corporate responsibility: CSR and the governance of child labor and core labor rights in the 1990s
 11. Anne Roepstorff
Holdning for handling – en etnologisk undersøgelse af Virksomheders Sociale Ansvar/CSR

12. Claus Bajlum
Essays on Credit Risk and Credit Derivatives
 13. Anders Bojesen
The Performative Power of Competence – an Inquiry into Subjectivity and Social Technologies at Work
 14. Satu Reijonen
*Green and Fragile
A Study on Markets and the Natural Environment*
 15. Ilduara Busta
*Corporate Governance in Banking
A European Study*
 16. Kristian Anders Hvass
*A Boolean Analysis Predicting Industry Change: Innovation, Imitation & Business Models
The Winning Hybrid: A case study of isomorphism in the airline industry*
 17. Trine Paludan
*De uvidende og de udviklingsparate
Identitet som mulighed og restriktion
blandt fabriksarbejdere på det aftayloriserede fabriksgulv*
 18. Kristian Jakobsen
Foreign market entry in transition economies: Entry timing and mode choice
 19. Jakob Elming
Syntactic reordering in statistical machine translation
 20. Lars Brømsøe Termansen
*Regional Computable General Equilibrium Models for Denmark
Three papers laying the foundation for regional CGE models with agglomeration characteristics*
 21. Mia Reinholt
The Motivational Foundations of Knowledge Sharing
 22. Frederikke Krogh-Meibom
*The Co-Evolution of Institutions and Technology
– A Neo-Institutional Understanding of Change Processes within the Business Press – the Case Study of Financial Times*
 23. Peter D. Ørberg Jensen
OFFSHORING OF ADVANCED AND HIGH-VALUE TECHNICAL SERVICES: ANTECEDENTS, PROCESS DYNAMICS AND FIRMLEVEL IMPACTS
 24. Pham Thi Song Hanh
Functional Upgrading, Relational Capability and Export Performance of Vietnamese Wood Furniture Producers
 25. Mads Vangkilde
*Why wait?
An Exploration of first-mover advantages among Danish e-grocers through a resource perspective*
 26. Hubert Buch-Hansen
*Rethinking the History of European Level Merger Control
A Critical Political Economy Perspective*
- 2009**
1. Vivian Lindhardtsen
From Independent Ratings to Communal Ratings: A Study of CWA Raters' Decision-Making Behaviours
 2. Guðrið Weihe
Public-Private Partnerships: Meaning and Practice
 3. Chris Nøkkentved
*Enabling Supply Networks with Collaborative Information Infrastructures
An Empirical Investigation of Business Model Innovation in Supplier Relationship Management*
 4. Sara Louise Muhr
Wound, Interrupted – On the Vulnerability of Diversity Management

5. Christine Sestoft
Forbrugeradfærd i et Stats- og Livsformsteoretisk perspektiv
6. Michael Pedersen
Tune in, Breakdown, and Reboot: On the production of the stress-fit self-managing employee
7. Salla Lutz
Position and Reposition in Networks – Exemplified by the Transformation of the Danish Pine Furniture Manufacturers
8. Jens Forssbæk
Essays on market discipline in commercial and central banking
9. Tine Murphy
Sense from Silence – A Basis for Organised Action
How do Sensemaking Processes with Minimal Sharing Relate to the Reproduction of Organised Action?
10. Sara Malou Strandvad
Inspirations for a new sociology of art: A sociomaterial study of development processes in the Danish film industry
11. Nicolaas Mouton
On the evolution of social scientific metaphors: A cognitive-historical enquiry into the divergent trajectories of the idea that collective entities – states and societies, cities and corporations – are biological organisms.
12. Lars Andreas Knutsen
Mobile Data Services: Shaping of user engagements
13. Nikolaos Theodoros Korfiatis
Information Exchange and Behavior
A Multi-method Inquiry on Online Communities
14. Jens Albæk
Forestillinger om kvalitet og tværfaglighed på sygehuse
– skabelse af forestillinger i læge- og plejegrupperne angående relevans af nye idéer om kvalitetsudvikling gennem tolkningsprocesser
15. Maja Lotz
The Business of Co-Creation – and the Co-Creation of Business
16. Gitte P. Jakobsen
Narrative Construction of Leader Identity in a Leader Development Program Context
17. Dorte Hermansen
“Living the brand” som en brandorienteret dialogisk praksis: Om udvikling af medarbejdernes brandorienterede dømmekraft
18. Aseem Kinra
Supply Chain (logistics) Environmental Complexity
19. Michael Nørager
How to manage SMEs through the transformation from non innovative to innovative?
20. Kristin Wallevik
Corporate Governance in Family Firms
The Norwegian Maritime Sector
21. Bo Hansen Hansen
Beyond the Process
Enriching Software Process Improvement with Knowledge Management
22. Annemette Skot-Hansen
Franske adjektivisk afledte adverbier, der tager præpositionssyntagmer indledt med præpositionen à som argumenter
En valensgrammatisk undersøgelse
23. Line Gry Knudsen
Collaborative R&D Capabilities
In Search of Micro-Foundations

24. Christian Scheuer
*Employers meet employees
Essays on sorting and globalization*

25. Rasmus Johnsen
*The Great Health of Melancholy
A Study of the Pathologies of Perfor-
mativity*

TITLER I ATV PH.D.-SERIEN

1992

1. Niels Kornum
*Servicesamkørsel – organisation, øko-
nomi og planlægningsmetoder*

1995

2. Verner Worm
*Nordiske virksomheder i Kina
Kulturspecifikke interaktionsrelationer
ved nordiske virksomhedsetableringer i
Kina*

1999

3. Mogens Bjerre
*Key Account Management of Complex
Strategic Relationships
An Empirical Study of the Fast Moving
Consumer Goods Industry*

2000

4. Lotte Darsø
*Innovation in the Making
Interaction Research with heteroge-
neous Groups of Knowledge Workers
creating new Knowledge and new
Leads*

2001

5. Peter Hobolt Jensen
*Managing Strategic Design Identities
The case of the Lego Developer Net-
work*

2002

6. Peter Lohmann
*The Deleuzian Other of Organizational
Change – Moving Perspectives of the
Human*

7. Anne Marie Jess Hansen
*To lead from a distance: The dynamic
interplay between strategy and strate-*

*gizing – A case study of the strategic
management process*

2003

8. Lotte Henriksen
*Videndeling
– om organisatoriske og ledelsesmæs-
sige udfordringer ved videndeling i
praksis*

9. Niels Christian Nickelsen
*Arrangements of Knowing: Coordi-
nating Procedures Tools and Bodies in
Industrial Production – a case study of
the collective making of new products*

2005

10. Carsten Ørts Hansen
*Konstruktion af ledelsesteknologier og
effektivitet*

TITLER I DBA PH.D.-SERIEN

2007

1. Peter Kastrup-Misir
*Endeavoring to Understand Market
Orientation – and the concomitant
co-mutation of the researched, the
researcher, the research itself and the
truth*

2009

1. Torkild Leo Thellefsen
*Fundamental Signs and Significance-
effects
A Semeiotic outline of Fundamental
Signs, Significance-effects, Knowledge
Profiling and their use in Knowledge
Organization and Branding*

2. Daniel Ronzani
*When Bits Learn to Walk Don't Make
Them Trip
Technological Innovation and the Role
of Regulation by Law in Information
Systems Research: the Case of Radio
Frequency Identification (RFID)*