

Zárate-Solano, Héctor M.; Zapata-Sanabria, Daniel R.

Working Paper

Forecasting inflation expectations from the CESifo World Economic Survey: An empirical application in inflation targeting countries

IDB Working Paper Series, No. IDB-WP-880

Provided in Cooperation with:

Inter-American Development Bank (IDB), Washington, DC

Suggested Citation: Zárate-Solano, Héctor M.; Zapata-Sanabria, Daniel R. (2018) : Forecasting inflation expectations from the CESifo World Economic Survey: An empirical application in inflation targeting countries, IDB Working Paper Series, No. IDB-WP-880, Inter-American Development Bank (IDB), Washington, DC, <https://doi.org/10.18235/0001264>

This Version is available at:

<https://hdl.handle.net/10419/208106>

Standard-Nutzungsbedingungen:

Die Dokumente auf EconStor dürfen zu eigenen wissenschaftlichen Zwecken und zum Privatgebrauch gespeichert und kopiert werden.

Sie dürfen die Dokumente nicht für öffentliche oder kommerzielle Zwecke vervielfältigen, öffentlich ausstellen, öffentlich zugänglich machen, vertreiben oder anderweitig nutzen.

Sofern die Verfasser die Dokumente unter Open-Content-Lizenzen (insbesondere CC-Lizenzen) zur Verfügung gestellt haben sollten, gelten abweichend von diesen Nutzungsbedingungen die in der dort genannten Lizenz gewährten Nutzungsrechte.

Terms of use:

Documents in EconStor may be saved and copied for your personal and scholarly purposes.

You are not to copy documents for public or commercial purposes, to exhibit the documents publicly, to make them publicly available on the internet, or to distribute or otherwise use the documents in public.

If the documents have been made available under an Open Content Licence (especially Creative Commons Licences), you may exercise further usage rights as specified in the indicated licence.



<https://creativecommons.org/licenses/by-nc-nd/3.0/igo/legalcode>

IDB WORKING PAPER SERIES Nº IDB-WP-880

Forecasting Inflation Expectations from the CESifo World Economic Survey:

An Empirical Application in Inflation Targeting Countries

Héctor M. Zárate-Solano
Daniel R. Zapata-Sanabria

Inter-American Development Bank
Department of Research and Chief Economist

July 2018

Forecasting Inflation Expectations from the CESifo World Economic Survey:

An Empirical Application in Inflation Targeting Countries

Héctor M. Zárate-Solano
Daniel R. Zapata-Sanabria

Banco de la República, Colombia

Cataloging-in-Publication data provided by the
Inter-American Development Bank
Felipe Herrera Library

Zárate-Solano, Héctor M.

Forecasting inflation expectations from the CESifo World Economic Survey: an empirical application in inflation targeting countries / Héctor M. Zárate-Solano, Daniel R. Zapata-Sanabria.

p. cm. — (IDB Working Paper Series ; 880)

Includes bibliographic references.

1. Inflation (Finance)-Colombia-Forecasting. 2. Inflation (Finance)-Colombia-Econometric models. I. Zapata-Sanabria, Daniel R. II. Inter-American Development Bank. Department of Research and Chief Economist. III. Title. IV. Series. IDB-WP-880

<http://www.iadb.org>

Copyright © 2018 Inter-American Development Bank. This work is licensed under a Creative Commons IGO 3.0 Attribution-NonCommercial-NoDerivatives (CC-IGO BY-NC-ND 3.0 IGO) license (<http://creativecommons.org/licenses/by-nc-nd/3.0/igo/legalcode>) and may be reproduced with attribution to the IDB and for any non-commercial purpose, as provided below. No derivative work is allowed.

Any dispute related to the use of the works of the IDB that cannot be settled amicably shall be submitted to arbitration pursuant to the UNCITRAL rules. The use of the IDB's name for any purpose other than for attribution, and the use of IDB's logo shall be subject to a separate written license agreement between the IDB and the user and is not authorized as part of this CC-IGO license.

Following a peer review process, and with previous written consent by the Inter-American Development Bank (IDB), a revised version of this work may also be reproduced in any academic journal, including those indexed by the American Economic Association's EconLit, provided that the IDB is credited and that the author(s) receive no income from the publication. Therefore, the restriction to receive income from such publication shall only extend to the publication's author(s). With regard to such restriction, in case of any inconsistency between the Creative Commons IGO 3.0 Attribution-NonCommercial-NoDerivatives license and these statements, the latter shall prevail.

Note that link provided above includes additional terms and conditions of the license.

The opinions expressed in this publication are those of the authors and do not necessarily reflect the views of the Inter-American Development Bank, its Board of Directors, or the countries they represent.



Abstract*

This paper has two purposes. First, it evaluates the responses to the questions on inflation expectations in the World Economic Survey (WES) for 16 inflation targeting countries. Second, it compares inflation expectation forecasts across countries by using a two-step approach that selects the most accurate linear or non-linear forecasting method for each country. Then, Self-Organizing Maps are used to cluster inflation expectations, setting as a benchmark June 2014, when there was a sharp decline in oil prices. Analyzing inflation expectations in the context of this price change makes it possible to distinguish between countries that anticipated the oil shock smoothly and those that had to significantly adjust their expectations. The main findings from the WES in-sample comparison suggest that expert forecasts of inflation expectations are systematically distorted in 83 percent of the countries in the sample. On the other hand, the out of sample forecast analysis indicates that Non-linear Artificial Neural Networks combined with Bayesian regularization outperform ARIMA linear models for longer forecasting horizons. This holds true for countries with both soft and brisk changes of expectations. However, when forecasting one step ahead, the performance between the two methods is similar.

JEL classifications: C02, C222, C45, C63, E27

Keywords: Inflation expectations, Machine learning, Self-organizing maps, Nonlinear auto-regressive neural network, Expectation surveys, Time series models

* This paper was undertaken as part of CEMLA's Joint Research Program 2017 coordinated by the Central Bank of Colombia. The authors gratefully acknowledge insights and technical advice provided by the Financial Stability and Development (FSD) Group of the Inter-American Development Bank in the process of writing this document. We also wish to thank Johanna Garnitz at the IFO Institute for Economic Research for providing the data used in this paper. Also, we have greatly benefited from discussions with professor Marcellino Massimiliano. The opinions expressed in this publication are those of the authors and do not reflect the views of CEMLA, the FSD group, the Inter-American Development Bank or the Banco de la República or its board of Directors.

Zárate-Solano: Senior Econometrician, Banco de la República Colombia (Central Bank of Colombia):
email: hzaratso@banrep.gov.co

Zapata-Sanabria: Research Assistant, Banco de la República Colombia (Central Bank of Colombia).
email: danielr.zapata@urosario.edu.co

1. Introduction

Cross-country data from economic expectations surveys have recently highlighted the importance of analyzing and forecasting public expectations to gain insight into crucial empirical issues in macroeconomics. Expectations can influence the future path of real economic variables and help guide policy decision-makers, and inflation expectations are particularly important for countries that utilize inflation targeting as their primary monetary policy framework. The usefulness of inflation expectations is manifested in various realms of economic analysis. They are critical for i) testing theories of informational inflation rigidity (Coibion et al., 2012); ii) estimating key structural parameters, such as the intertemporal substitution elasticity (Crump et al., 2015); iii) testing public understanding of monetary policy, such as the Taylor rule (Carvalho and Nechio, 2014); and iv) assessing how well inflation expectations may be anchored among economic agents, which is key in assessing the effectiveness of central bank communication. Lastly, New Keynesian macroeconomic models have successfully used inflation expectations to predict real inflation (Henzel and Wollmershäuser, 2008).

Expectation surveys have featured a wide range of respondents, including economic experts, central bankers, financial agents, consumers, and firms. Those surveyed often have to make important decisions that take into account inflation and survey data, and their responses provide information on the effectiveness of economic policies and institutional confidence. The World Economic Survey (WES) collects data on inflation expectations across countries and surveys more than 1,000 economic experts in approximately 120 countries. The respondents evaluate present economic conditions and predict the economic outlook of the country in which they reside, giving special attention to price trends in their answers to both qualitative and quantitative questions.

Thus we must assess the suitability of WES data surveys and select the appropriate methods to accurately forecast inflation expectations. In regard to suitability, we can use simple exploratory data analysis based on time plots and correlations, and we can calculate the in-sample forecast errors within a sample of 16 inflation-targeting countries. To find the appropriate forecasting method, we use a two-step approach centered on both clustering and forecasting techniques. Specifically, we analyze the June 2014 oil price shock and its effect on inflation expectations and other macroeconomic indicators. We consider this oil shock

relevant because the decline in oil prices was significantly larger than in any previous episode during the past 30 years. The decline weakened fiscal policy and reduced the economic activity of oil exporters, but for oil importers, inflationary and fiscal pressures were alleviated. The oil price shock is also significant because it affected growth and inflation through two channels: input costs and real income shifts. Changes through either of these channels then led to changes in inflation expectations. Thus, we evaluate different forecasting methods in the period after the oil shock from Q3 2014 to Q2 2016. To obtain optimal forecasts, a combination of clustering and forecasting analysis can be used. Data visualization techniques are useful for discovering important characteristics and potential clusters of economic agents. In addition, we use machine learning and statistical methodologies to improve inflation expectation forecasts based on qualitative and quantitative questions from the WES.

This paper examines the data on inflation expectations from the WES for 16 inflation-targeting countries. Then, by making use of Self-Organizing Maps (SOM) we cluster agents' expectations for these countries to classify them either as "soft" or "brisk" based on the speed of their expectations change after the oil shock of 2014 (Claveria, Monte and Torra, 2016). After that, we combine the SOM representations with different forecasting methods to select models for inflation expectation forecasting. The ARIMA model reflects the linear class of models and the Non-linear Auto-regressive Neural network (NAR-NN) reflects the non-linear class of models.

Our main findings are the following. First, we present evidence of heterogeneity in the correlation patterns between inflation expectations and observed inflation. There are increasing, descending, and inverted U-shaped correlations over time. Regarding frequency domain analysis, the highest coherence values were often found in periods of higher frequencies in most countries, implying that there is a strong relationship between cycles of short periods.

According to the WES forecast error analysis, we observe that even though the forecasts meet at least the minimum standard when compared to a random walk, economic experts have made systematic errors in their predictions. That is, inflation was under-predicted while increasing and over-predicted while declining in most of the countries. Moreover, the mean squared error decomposition illustrated that there were systematic distortions in the inflation forecasts in around 83 percent of the countries. The evidence

suggests that although the accuracy of the forecasts increases as the forecasting horizon decreases, this relationship is not monotonic. This finding does not support the hypothesis that forecasts have improved over time, which may signal that there is a non-linear data-generating process.

Second, turning to a much more complex analysis, the SOM representation allows us to cluster countries based on the evolution of inflation expectations before the oil price shock. It is important to note that the low inflation expectations cluster is relatively small compared to the high and neutral clusters for inflation-targeting countries. We find that in the one step-forward forecasts, the neural network only slightly improves on forecasts of the ARIMA, but that it outperforms the ARIMA model in the two step-forward forecasts for Canada, Colombia, Chile, Poland, Hungary, and Sweden. Therefore, using a non-linear neural network along with Bayesian regularization leads to an improvement in expectations forecasts.

This paper contains five sections apart from this introduction and proceeds as follows. In Section 2 we describe the WES data and evaluate the responses to both qualitative and quantitative inflation questions. In Section 3, we provide the methodologies for clustering and forecasting, emphasizing the merits of the artificial neural network approach. In Section 4, we summarize the main results, including the cluster analysis and forecasting accuracy. Finally, in Section 5 we present our conclusions and propose future lines of research.

2. World Economic Survey Data and Their Suitability for Forecasting Inflation

Surveying economic experts across different countries, the CESifo World Economic Survey (WES) carried out by the IFO Institute for Economic Research collects data on how experts view their country's economic outlook. In this paper, we use the term economic experts to include representatives of multinational enterprises, banks, chambers of commerce, academic institutions, and individual economists.

The questionnaire is distributed every quarter (January, April, July, and October) with qualitative and quantitative questions related to the general economic situation and expectations regarding key macroeconomic indicators: economic growth, interest rates, consumption, capital, exchange rates, and inflation, among others.¹ The questions on the

¹ A survey form of the World Economic Survey, the WES questionnaire, is included in Appendix A, see Figure 14.

expected inflation rate, which are the main focus of this paper, reveal qualitative and quantitative information on the economic experts of each country. Thus, the participants are asked to give their expectations of what the inflation rate will be by the end of the next six months. They indicate “HIGHER” for an expected rise in the inflation rate, “ABOUT THE SAME” for no change in the inflation rate, and “LOWER” for an expected fall in the expected inflation rate by the end of the next six months. We transformed these responses into a cardinal time series of expected inflation by applying the following standard approach: where the response is considered high, a numerical value of 9 is coded; where the response is considered neutral, a value of 5 is coded; and where the response is considered low, a value of 1 is recorded. Next, we calculate the average rating for each question for each country. Traditionally, analysts have categorized these country ratings by terming an average greater than 5 a positive zone and an average below 5 a negative zone. The neutral zone depends simply on the analyst’s subjective decision. One of the results of this paper is to establish the limitations that come with this three-zone categorization and instead, we let the data speak for itself.

In the quantitative question the experts of each country are asked to predict the future inflation rate: “the rate of inflation on average this year will be: % p.a.” We analyze the responses to this question through an in-sample statistical analysis of forecasting error. Further information on the WES can be found in Stangl (2007a and 2007b).

We analyze expectations for 16 inflation-targeting countries from Q3 1991 to Q2 2016. The countries included in our analysis are Brazil, Canada, Switzerland, Chile, Colombia, Czech Republic, United Kingdom, Hungary, Korea Republic, Mexico, Norway, Philippines, Poland, Sweden, Thailand, and South Africa.² The relationship between the indicator of WES inflation expectations and the observed annual inflation rate is illustrated through a simple exploratory analysis that uses time plots and correlation statistics.³ The observed inflation rate and the corresponding inflation expectations are depicted in Figure 1 for some selected countries. For each country, inflation was measured by annual changes in the Consumer Price Index. According to Figure 1, WES expectations move in tandem with actual inflation for

² Figure 11 in Appendix A contains the full-time series length.

³ To see the other countries’ inflation expectations, see Figure 15 in the Appendix.

most of the period under study except during idiosyncratic and global shocks that affected specific national economies.⁴

Figure 2 displays the correlation coefficient over time and the coherence as a function of the frequency between the WES inflation expectations and real annual inflation. The plot of the correlation coefficient shows the existence of different patterns of linear association. For example, while the correlation in Mexico has increased over time, it has decreased in Canada. On the other hand, Colombia has experienced an inverted u-shaped correlation pattern that peaks in the middle of 2002. According to frequency domain analysis, higher coherence was found in higher frequencies of the spectral distribution in most of the countries, which suggests that the relationship between inflation expectations and observed inflation is strong predominantly during short cycles. It is important to note that Asian countries have higher coherence in lower frequencies, which points to a different trend between expectation and observed inflation.⁵

⁴ In addition, we include a summary of the data, their histograms and correlations which are relevant to the SOM analysis: Figure 12 in the Appendix reveals the heterogeneity of the variables, and Figure 13 displays the correlation between them. Table 9 in the Appendix shows a brief summary of the WES expectations data.

⁵ To see the spectral decomposition of the other countries, see Figure 16 in the Appendix.

Figure 1. Comparison of Inflation Expectations with Observed Annual Inflation, Selected Countries

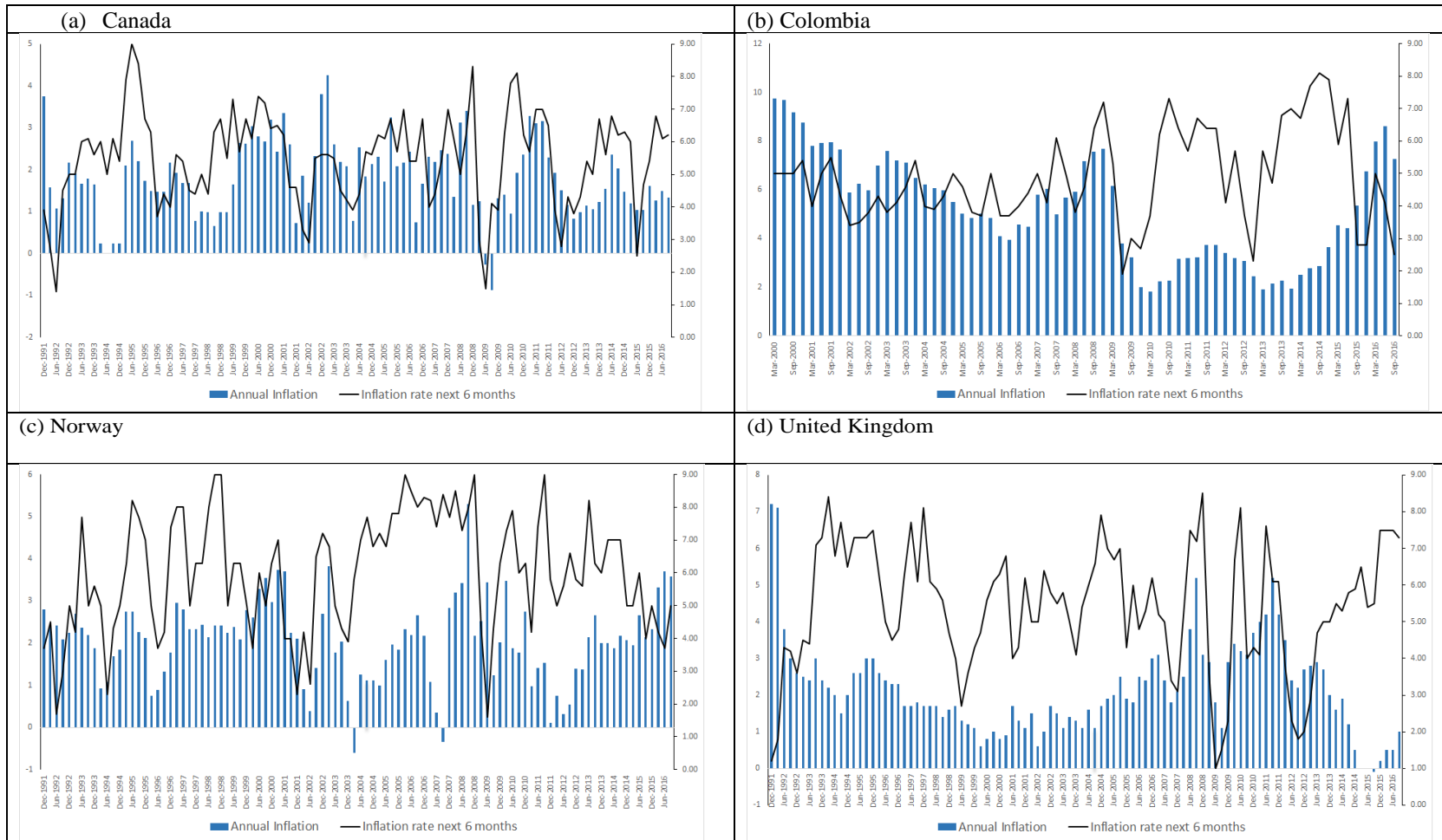

Source: WES survey and OECD statistics.

Figure 2. Correlation and Coherence Coefficients of Qualitative WES Inflation Expectation with Observed Annual Inflation

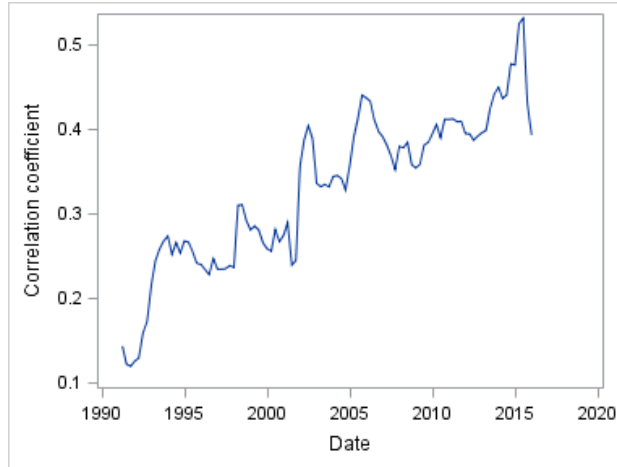

(a) Canada: Correlation over time

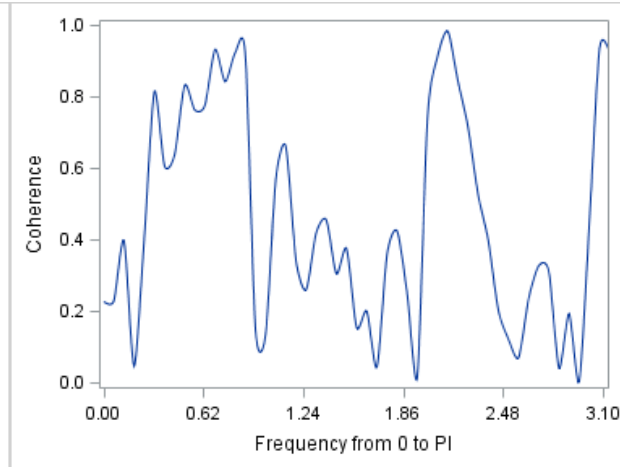

(b) Canada: Coherence

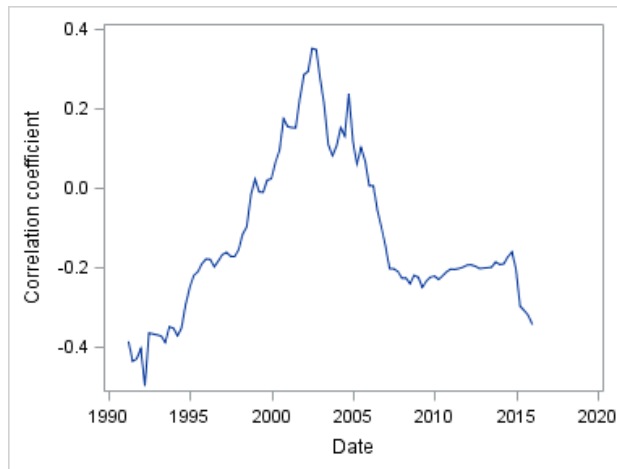

(c) Colombia: Correlation over time

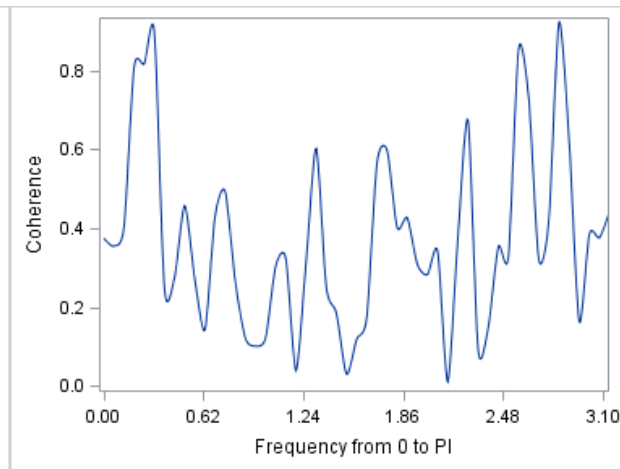

(d) Colombia: Correlation through frequency

Figure 2, continued

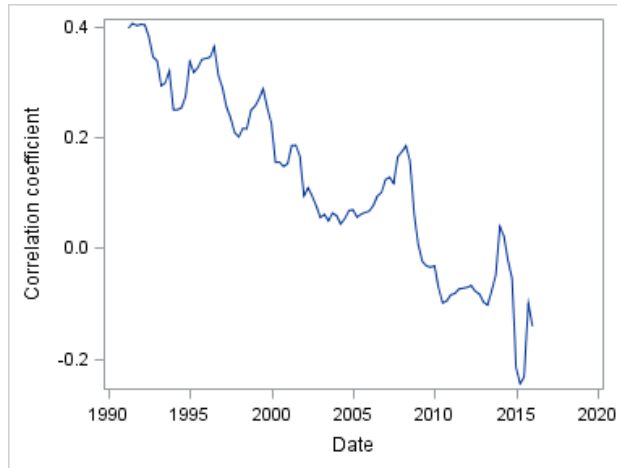

(e) Norway: Correlation over time

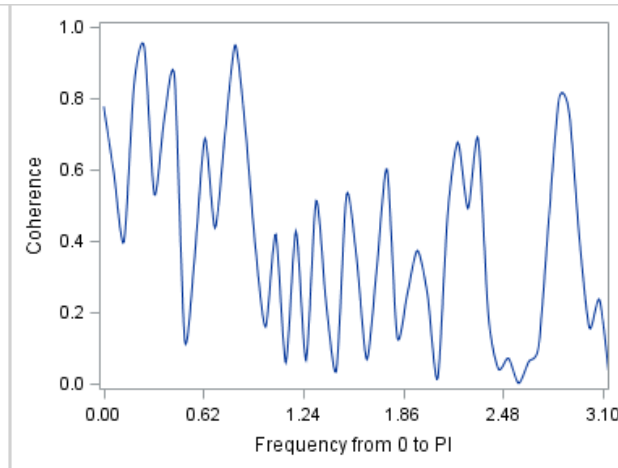

(f) Norway: Coherence

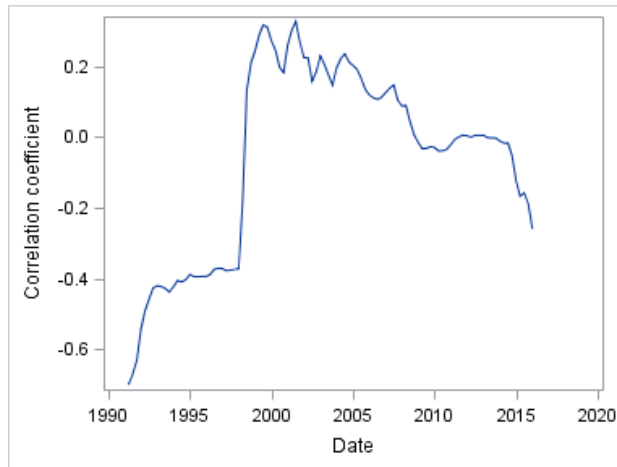

(g) United Kingdom: Correlation over time

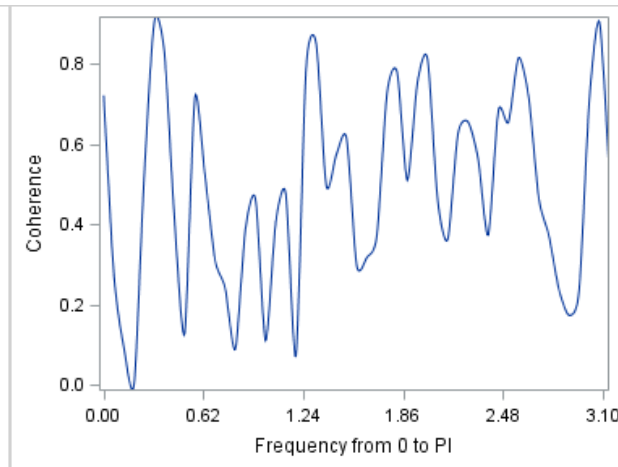

(h) United Kingdom: Coherence

Source: WES, OECD statistics and IMF data.

2.1 Quantitative Forecasting Inflation Expectations

In this section, we perform an in-sample forecasting analysis based on the forecasting error. We compute the forecasting error as the difference between annual average inflation based on the CPI and the corresponding quantitative WES inflation assessment from the survey question “the rate of inflation on average this year will be: % p.a.”. We follow previous work by Fildes and Stekler (2002) and Hammella and Haupt (2007). to quantify and examine the accuracy of WES forecasts at different horizons. It is important to note that the experts receive more information from quarter to quarter during the year as data on the observed inflation rate is released.

2.1.1 Statistical Analysis of the Forecasting Error

The forecasting error is calculated in the following way:

$$e(L, Q(h), t) = \bar{p}(L, t) - q(L, Q(h), t) \quad (1)$$

where L = countries, h = I, II, III, IV, and t = 1991, . . . , 2016. First, we compute some standard error statistics for each quarter including the RMSFE (root mean squared forecast error), MAE (mean absolute error), and Theil U-statistic. See Hamella and Haupt (2007).⁶

Second, we used the additive mean squared error decomposition proposed by Theil in 1966 (see Theil et al., 1975) to obtain insight into the structure of the forecast error. The decomposition is meant to illustrate how the error changes conditional on the different forecasting horizons through three components: the bias share V_h , the spread share S_h , and the covariance share K_h . The V_h bias component measures systematic distortions in the forecast, where bias should decrease through forecast horizons only if the expectations are anchored. S_h measures the dispersion between observed inflation and the WES forecast. Finally, K_h assesses the linear association between average inflation and the WES forecast; if the correlation is perfect then $K = 0$. Notice that the components should sum up to one.

⁶ The respective statistics equations are presented in Appendix A.3, and MAE and U-statistic results are in Tables 10 and 11, respectively. See Appendix.

2.1.2 *Quantitative Inflation Expectation Results*

Tables 1 and 2 summarize the RMSFE and its decomposition for the sample of countries at different time horizons. The results illustrate that the RMSFE decreases throughout the year for countries such as Switzerland, Colombia, Korea, and Norway. Nevertheless, there are some countries which exhibit a different pattern in which the last forecast is more uncertain. The countries in this group include Brazil, Canada, Chile, Czech Republic, and United Kingdom. The heterogeneity among RMSFE values across countries can be explained by the fact that the RMSFE relies on the restricted assumption that survey forecasters have a symmetric loss function. The RMSFE also depends on the unit of measurement and the inflation rate in each country. These diagnoses remain by observing the MAE and U-statistics. Figure 3 compares the respective observed annual inflation (bar line) and the WES expectation for each quarter for some selected countries.^{7,8}

The evidence for Colombia suggests that actual annual inflation was overestimated during the period from 2000 to 2003, and from 2003 to 2007 the expectations were close to the observed inflation rate. The 2008 financial crises led expectations to undershoot observed inflation for a short period of time, but soon after, expectations began to overshoot observed inflation until 2014. Eventually, the 2014 oil shock induced a period of undershooting. There are different patterns across the countries. For example, in Mexico expectations were close to actual inflation until the oil shock, but after the shock, they overestimated observed inflation rates. In Tables 3 and 4 we count the number of years in which inflation was overestimated and underestimated respectively by respondents, to the quarterly WES survey. For instance, the results indicate that annual inflation in Colombia was overestimated, on average, in 14 of 25 years and for Mexico in 17 of 26 years. There is evidence that systematic overestimation was greater than underestimation. The exception occurs in the case of Brazil in which, on average, in 15 of 26 years inflation was underestimated by economic experts.

⁷ To see other countries' quantitative inflation expectations, see Figure 17 in Appendix A.3

⁸ The quarter-specific forecasting error by country is plotted in Figure 18, Appendix A.3.

Finally, a cross-country comparison using the U-statistic confirms that the WES-forecasts in every country at least meet the minimum standard when compared with the random walk alternative.

**Table 1. Root Mean Squared Forecast Errors of WES Survey
Quantitative Inflation Question, Q1 1991 to Q3 2016**

Countries	4-step forecast (QI)	3-step forecast (QII)	2-step forecast (QIII)	1-step forecast (QIV)	
Brazil	182.71		321.48	354.44	431.01
Canada		0.70	0.57	0.42	0.58
Switzerland		0.75	0.50	0.41	0.38
Chile		1.23	1.46	1.36	1.66
Colombia		1.80	1.67	1.43	1.00
Czech Republic		4.97	4.81	6.87	3.08
United Kingdom		0.89	0.88	0.90	0.99
Korea		1.61	1.41	1.16	1.09
Mexico		3.37	2.03	4.48	3.62
Norway		0.78	0.65	0.52	0.39
Hungary		2.12	1.32	1.12	1.54
Philippines		2.29	1.77	1.29	1.22
Poland		5.48	2.07	10.48	11.47
Sweden		1.05	0.80	0.99	1.19
Thailand		2.05	1.56	1.51	1.04
South Africa		1.77	1.57	1.49	1.27

Table 2. Theil Error Decomposition of WES Forecast Errors, Q1 1991 to Q2 2016

Countries	Error decomposition	4-step forecast (QI)	3-step forecast (QII)	2-step forecast (QIII)	1-step forecast (QIV)
	V	0.13	0.06	0.07	0.01
Brazil	S	0.84	0.81	0.53	0.10
	K	0.06	0.14	0.45	0.92
Canada	V	0.16	0.20	0.31	0.16
	S	0.05	0.14	0.26	0.26
	K	0.83	0.70	0.46	0.61
Switzerland	V	0.22	0.32	0.30	0.19
	S	0.22	0.28	0.37	0.54
	K	0.60	0.55	0.35	0.31
Chile	V	0.00	0.02	0.05	0.02
	S	0.02	0.20	0.74	0.75
	K	1.02	0.84	0.25	0.27
Colombia	V	0.003	0.06	0.04	0.01
	S	0.08	0.02	0.05	0.33
	K	0.96	0.99	0.95	0.71
Czech R.	V	0.10	0.14	0.06	0.02
	S	0.17	0.21	0.33	0.002
	K	0.77	0.77	0.65	1.02
United K.	V	0.23	0.26	0.18	0.14
	S	0.16	0.28	0.43	0.30
	K	0.64	0.56	0.43	0.60
	V	0.37	0.44	0.52	0.39
Korea	S	0.03	0.002	0.0003	0.02
	K	0.62	0.45	0.50	0.62
	V	0.03	0.13	0.01	0.01
Mexico	S	0.43	0.002	0.11	0.03
	K	0.57	1.04	0.92	1.01
Norway	V	0.06	0.02	0.08	0.02
	S	0.19	0.14	0.13	0.18
	K	0.79	0.79	0.83	0.84
Hungary	V	0.04	0.15	0.01	0.01
	S	0.00	0.08	0.11	0.27
	K	1.00	0.96	0.92	0.76
Philippines	V	0.20	0.15	0.18	0.35
	S	0.01	0.15	0.27	0.07
	K	0.81	0.76	0.59	0.61
Poland	V	0.06	1.20	0.07	0.05
	S	0.44	0.05	0.58	0.36
	K	0.54	0.96	0.39	0.62
Sweden	V	0.35	0.28	0.16	0.03
	S	0.07	0.39	0.49	0.74
	K	0.61	0.39	0.39	0.27
Thailand	V	0.18	0.47	0.40	0.56
	S	0.005	0.001	0.001	0.002
	K	0.84	0.77	0.62	0.45
	V	0.14	0.25	0.27	0.32
South A.	S	0.17	0.21	0.25	0.18
	K	0.72	0.65	0.51	0.53

Table 3. Overestimation of WES Forecasts, QI 1991 to Q2 2016

Countries	4-step forecast (QI)	3-step forecast (QII)	2-step forecast (QIII)	1-step forecast (QIV)	
Brazil	10 cases of (26)	10 cases of (26)	10 cases of (25)	13 cases of (25)	
Mean		-0.95	-5.09	-4.54	-70.26
Std. Deviation		1	11.83	11.75	201.59
Canada	16 cases of (26)	16 cases of (26)	17 cases of (25)	20 cases of (25)	
Mean		-0.64	-0.55	-0.42	-0.4
Std. Deviation		0.58	0.42	0.27	0.42
Switzerland	20 cases of (26)	18 cases of (26)	19 cases of (25)	19 cases of (25)	
Mean		-0.61	-0.45	-0.36	-0.3
Std. Deviation		0.44	0.27	0.27	0.24
Chile	15 cases of (26)	15 cases of (26)	12 cases of (25)	15 cases of (25)	
Mean		-0.9	-0.91	-0.61	-0.56
Std. Deviation		0.72	0.7	0.54	0.45
Colombia	13 cases of (26)	15 cases of (26)	13 cases of (25)	13 cases of (25)	
Mean		-1.23	-1.23	-1.15	-0.54
Std. Deviation		1.41	1.53	1.32	0.36
Czech Republic	21 cases of (26)	18 cases of (26)	19 cases of (25)	20 cases of (25)	
Mean		-2.36	-2.05	-2.48	-1.15
Std. Deviation		4.94	5.48	7.6	2.53
United Kingdom	20 cases of (26)	19 cases of (26)	17 cases of (25)	20 cases of (25)	
Mean		-0.78	-0.76	-0.78	-0.71
Std. Deviation		0.5	0.49	0.52	0.47
Korea	20 cases of (26)	24 cases of (26)	22 cases of (25)	20 cases of (25)	
Mean		-1.46	-1.18	-0.99	-0.91
Std. Deviation		1.06	0.89	0.74	0.82
Mexico	17 cases of (26)	18 cases of (26)	15 cases of (25)	17 cases of (25)	
Mean		-0.8	-0.96	-2.15	-1.12
Std. Deviation		0.71	1.73	4.94	3.28
Norway	16 cases of (26)	18 cases of (26)	15 cases of (25)	14 cases of (25)	
Mean		-0.64	-0.52	-0.48	-0.33
Std. Deviation		0.51	0.43	0.32	0.27
Hungary	17 cases of (26)	13 cases of (26)	15 cases of (25)	13 cases of (25)	
Mean		-1.5	-1.02	-0.77	-0.76
Std. Deviation		1.3	0.67	0.74	0.77
Philippines	21 cases of (26)	19 cases of (26)	19 cases of (25)	20 cases of (25)	
Mean		-1.77	-1.41	-1	-1.1
Std. Deviation		1.42	0.9	0.73	0.64
Poland	17 cases of (26)	19 cases of (26)	14 cases of (25)	13 cases of (25)	
Mean		-3.19	-1.21	-0.65	-0.45
Std. Deviation		5.62	1.28	0.39	0.28
Sweden	21 cases of (26)	21 cases of (26)	21 cases of (25)	20 cases of (25)	
Mean		-0.89	-0.66	-0.66	-0.59
Std. Deviation		0.71	0.41	0.44	0.3
Thailand	17 cases of (26)	20 cases of (26)	21 cases of (25)	22 cases of (25)	
Mean		-1.69	-1.27	-1.26	-0.91
Std. Deviation		1.83	1.2	1.04	0.65
South Africa	17 cases of (26)	18 cases of (26)	20 cases of (25)	21 cases of (25)	
Mean		-1.51	-1.27	-1.12	-0.93
Std. Deviation		1.15	0.41	0.62	0.23

Table 4. Underestimation of WES Forecasts, Q1 1991 to Q2 2016

Countries	4-step forecast (QI)	3-step forecast (QII)	2-step forecast (QIII)	1-step forecast (QIV)	
Brazil	16 cases of (26)	16 cases of (26)	15 cases of (25)	12 cases of (25)	
Mean	109.13		157.78	153.64	178.45
Std. Deviation		212.5	390.49	446.02	580.77
Canada	10 cases of (26)	10 cases of (26)	8 cases of (25)	5 cases of (25)	
Mean		0.29	0.23	0.16	0.45
Std. Deviation		0.25	0.19	0.1	0.46
Switzerland	6 cases of (26)	8 cases of (26)	6 cases of (25)	6 cases of (25)	
Mean		0.53	0.29	0.2	0.27
Std. Deviation		0.6	0.37	0.21	0.27
Chile	11 cases of (26)	11 cases of (26)	13 cases of (25)	10 cases of (25)	
Mean		1.07	1.22	1.15	1.48
Std. Deviation		0.87	1.42	1.33	2.09
Colombia	13 cases of (26)	11 cases of (26)	12 cases of (25)	12 cases of (25)	
Mean		1.43	1.01	0.67	0.78
Std. Deviation		1.1	0.73	0.83	1.06
Czech Republic	5 cases of (26)	8 cases of (26)	6 cases of (25)	5 cases of (25)	
Mean		1.76	0.79	1.03	2.33
Std. Deviation		2.32	1.15	1.74	3.93
United Kingdom	6 cases of (26)	7 cases of (26)	8 cases of (25)	5 cases of (25)	
Mean		0.72	0.62	0.47	1
Std. Deviation		0.36	0.57	0.75	1.13
Korea	6 cases of (26)	2 cases of (26)	3 cases of (25)	5 cases of (25)	
Mean		0.61	0.34	0.29	0.24
Std. Deviation		0.46	0.46	0.33	0.15
Mexico	9 cases of (26)	8 cases of (26)	10 cases of (25)	8 cases of (25)	
Mean		3.2	1.8	2.12	3.22
Std. Deviation		4.8	1.38	2.25	2.69
Norway	10 cases of (26)	8 cases of (26)	10 cases of (25)	11 cases of (25)	
Mean		0.55	0.51	0.35	0.29
Std. Deviation		0.5	0.39	0.26	0.23
Hungary	9 cases of (26)	13 cases of (26)	10 cases of (25)	12 cases of (25)	
Mean		1.58	0.94	0.9	1.21
Std. Deviation		1.92	1.1	0.86	1.57
Philippines	5 cases of (26)	7 cases of (26)	6 cases of (25)	5 cases of (25)	
Mean		2.04	1.56	0.87	0.76
Std. Deviation		1.52	1.41	1.32	0.82
Poland	9 cases of (26)	7 cases of (26)	11 cases of (25)	12 cases of (25)	
Mean		2.04	2.04	7.17	6.03
Std. Deviation		2.87	2.03	14.73	16.1
Sweden	5 cases of (26)	5 cases of (26)	4 cases of (25)	5 cases of (25)	
Mean		0.52	0.68	0.97	1.36
Std. Deviation		0.3	0.67	1.61	2.09
Thailand	9 cases of (26)	6 cases of (26)	4 cases of (25)	3 cases of (25)	
Mean		0.66	0.76	0.63	0.14
Std. Deviation		0.56	0.34	0.39	0.07
South Africa	9 cases of (26)	8 cases of (26)	5 cases of (25)	4 cases of (25)	
Mean		0.96	0.72	0.6	0.4
Std. Deviation		1.15	0.41	0.62	0.23

Figure 3. Countries' WES Quantitative Inflation Expectations, Annual Inflation and Inflation Targets

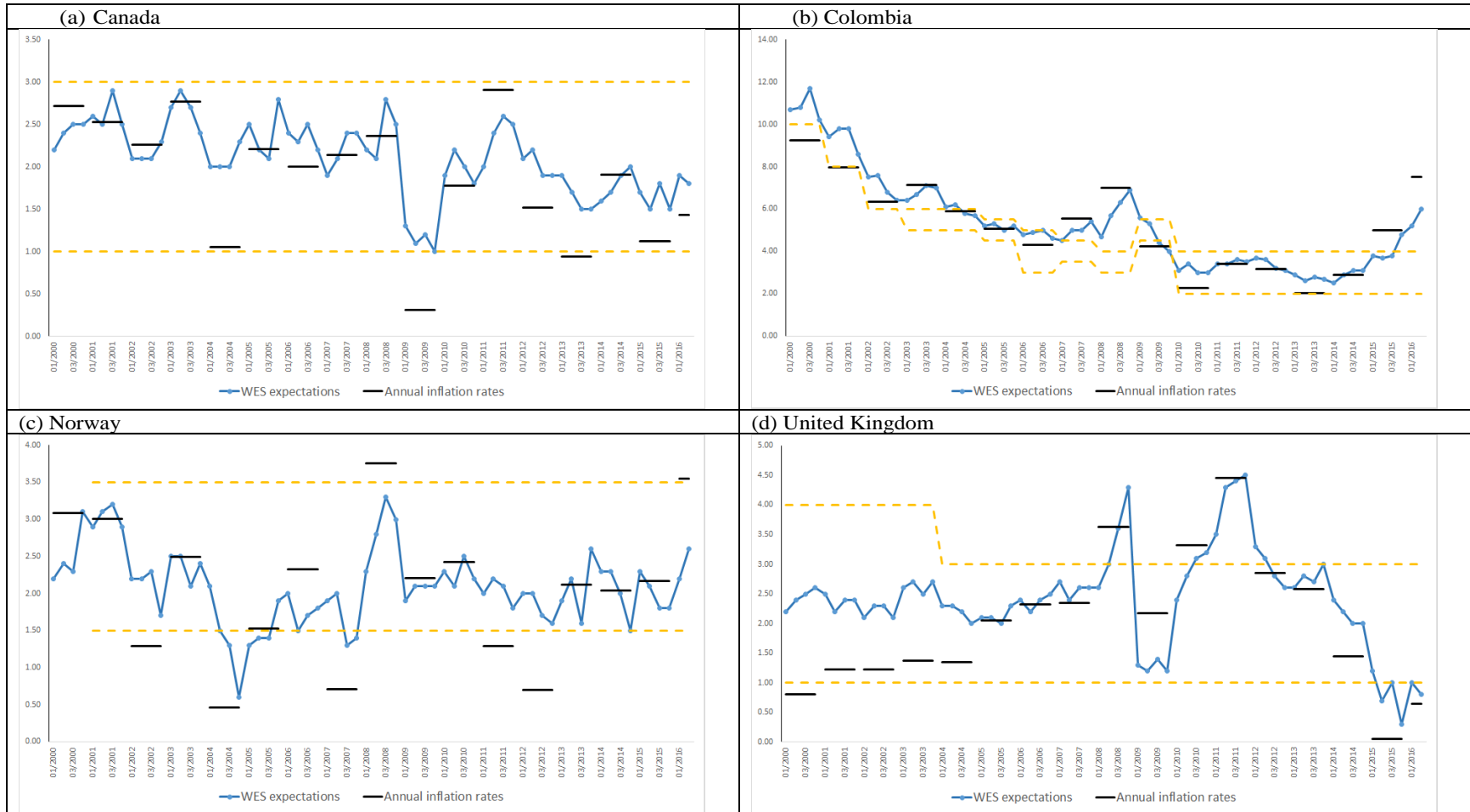

Source: WES survey, OECD statistics, and IMF data.

3. Methodology

In this section, we describe the Artificial Neural Networks (ANNs) models applied to cluster and forecast inflation expectations from the WES surveys. To cluster we relied on Kohonen self-organizing maps (SOMs), and to forecast we employed the multilayer perceptron from which the Non-linear autoregressive neuronal network, NAR-NN, is a subclass. The learning procedures to train ANNs is a statistical technique from which the weights are the relevant statistics that could be found through an optimal solution, White (1989). Previous work that employed ANNs to forecast inflation include Stock and Watson (1998) and Marcellino (2004) who conducted an extensive successful forecasting study on EMU macroeconomic variables. On the other hand, Bredahl Kok and Teräsvirta (2016) considered macroeconomic forecasting with a flexible single-hidden layer fed-forward neural network.

3.1 Artificial Neural Networks

In order to explain the ANNs framework, we start looking at the key points of the simple neural network model that form the base of the SOM and NAR-NN models.

ANNs are a type of parallel computing system consisting of several simple interconnected processors called neurons or nodes, through which there is a learning process that adjusts the system parameters to approximate non-linear functions between a set of inputs (variables) and the output (results). For more information, see Jain, Mao and Mohiuddin (1996).

Following Hagan et al. (2014), the simplest neuron model is composed of a scalar input p , called a single variable, which is multiplied by a scalar weight w . Then, w_p plus the bias b form the called net input n , which is sent to the activation function f , to produce the scalar neuron output a . However, the ANN's architecture may be more complex; they can have multiple inputs, layers, and neurons as shown in Figure 4.

Figure 4. A Three-Layer Neural Network

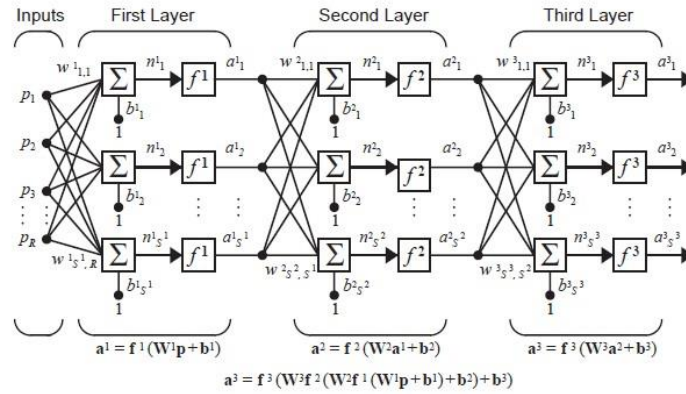

Source: Based on Hagan et al. (2014).

The parameters are constrained by weights and biases and are adjusted with some learning rule (e.g., Kohonen's learning rule), while the activation function is chosen according to the task at hand. For example, in the SOM, the competitive function is applied. These networks are fed forward, which means that there no loops between the outputs and inputs.⁹ To see more details about ANNs see Hagan et al. (2014).

3.2 Self-Organizing Maps

In this paper, Self-Organized Maps, proposed by Kohonen in 1982 (see Kohonen, 2001), were used to cluster economic agents' expectations before the oil shock. Furthermore, mapping those expectations after the shock in the resulting cluster map, we divide the observations into two groups based on whether the expectations adjusted briskly or softly. It is important to note that SOMs are competitive feed-forward networks based on unsupervised training and have the topology preservation property. This means that nearby input patterns should be represented on the map by nearby output units; see Kohonen (2001).

The SOM architecture consists of a two-layer network: in the first layer the inputs are multiplied with weights that were initialized as small numbers. Then the results are evaluated by a competitive function that produces a winning neuron (Best Matching unit). The weights are updated according to the learning rule, equation (2), and the neuron's neighborhood is updated as well. See Figure 5 below.

$$w_i(q) = (1 - \alpha)w_i(q - 1) + \alpha(p(q)) \quad (2)$$

⁹ In the NAR-NN Model, to perform multi-step forecasts, the network is transformed into a recurrent network after their parameters were trained as a feed-forward network.

Figure 5. A Self-Organizing Map of 5x5 Dimension

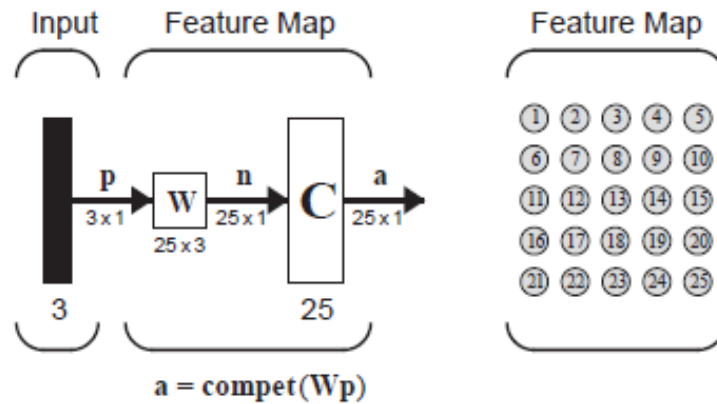

Source: Based on Hagan et al (2014).

The training stage for each iteration consists of weight adjustments for the winning neuron and its neighbors and these adjustments are undertaken using the learning rule. This process guarantees similarity between the inputs and the neurons represented on the feature map (the second layer of the map). At the end of the process, the resulting learned weights capture the data characteristics on the two-dimensional feature map (Hagan et al., 2014).

Kohonen suggested using rectangular and hexagonal neighborhoods. Furthermore, to improve the SOM's performance, we considered gradually decreasing the neighbor size during the training so that it only includes the winning neuron. Moreover, to consider the trade-off between fast learning and stability, the learning rate can be also decreased in this phase. This is because a high learning rate at the beginning of the training phase allows for quick but unstable learning. On the other hand, with a low rate, learning becomes slow but more stable.

Figure 6. Weight SOM Vectors of WES Expectations for the Next Six Months

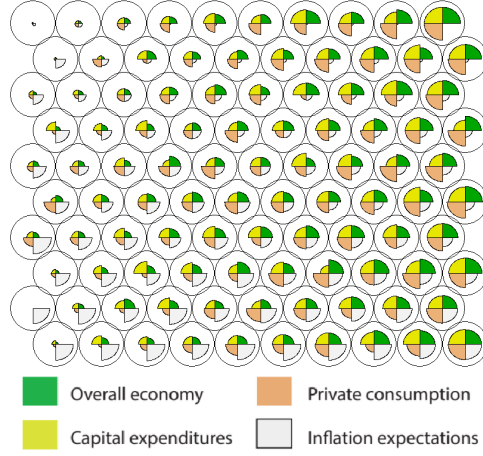

3.3 Nonlinear Auto-Regressive Neural Network

In this subsection, we describe the main issues of the NAR-NN methodology, including the selection of the training algorithm. The model assumes the current observation is explained by the compromise of two components: signal and noise. The first is an unknown function that is approximated by the neural network to the inflation expectation time series with an autoregressive structure. The second component is noise, which is assumed to be independent with zero mean. The model equation is stated below:

$$Y_t = g(Y_{t-1} + Y_{t-2} + \dots + Y_{t-p}) + e_t \quad (3)$$

$$Y_{t+1} = f^2 \left(\mathbf{w}^2 f^1 \left(\mathbf{w}^1 [Y_t, Y_{t-1}, \dots, Y_{t-p}] + \mathbf{b}^1 \right) + \mathbf{b}^2 \right) + e_{t+1} \quad (4)$$

In order to obtain the best approximation for g , the neural network architecture should meet the following three standard conditions: it has to avoid overfitting,¹⁰ the predicted error should be uncorrelated over time, and the cross-correlation function between the predicted errors and the observed time series should be close to zero. In this paper, we rely on the Bayesian regularization framework to approximate g in a parsimonious manner (Titterton, 2004).

The objective function for the Bayesian regularization setup is given by:

$$F(x) = \beta \sum_{t=1}^T (Y_t - \hat{Y}_t)^T (Y_t - \hat{Y}_t) + \alpha \sum_{i=1}^n x_i^2 \quad (5)$$

¹⁰ Overfitting is a characteristic that should be avoided and occurs when the neural network fit the data closely in the training set, but in the testing set and out of sample, the fitting is poor.

This is the weighted combination between the model fit and the smoothness. The parameter α penalizes model complexity and β reflects the goodness of fit. The term x_i^2 is the sum of the squared parameters values of the network, weights and biases.

Using the Bayes theorem sequentially, the joint posterior distribution of the parameters α and β , given the data D and the neural network model chosen M , is computed by multiplying the likelihood times the joint a priori distribution of α and β divided by the evidence:

$$P(\alpha, \beta | D, M) = \frac{P(D|\alpha, \beta, M)P(\alpha, \beta | M)}{P(D|M)} \quad (6)$$

The prior joint density for α and β is assumed from the uniform distribution. Consequently, the posterior can be obtained by computing the following probabilities:

$$P(D|\alpha, \beta, M) = \frac{P(D|X, \beta, M)P(X|\alpha, M)}{P(X|D, \alpha, \beta, M)} \quad (7)$$

$$P(X|D, \alpha, \beta, M) = \frac{P(D|X, \beta, M)P(X|\alpha, M)}{P(D|\alpha, \beta, M)} \quad (8)$$

For more technical details and the full training algorithm see Hagan et al. (2014).

The adaptation of the algorithm requires a neural network architecture, M , which means we have to pick the number of neurons in the input layer, the number of hidden layers, the number of neurons per hidden layer, and the number of neurons in the output layer. For more details see Zhang, Patuwo and Hu (1998).

Bayesian regularization guarantees that the parameter sum is the optimal given data. In order to optimize the regularization parameters, the objective function $F(x)$ should be minimized following the Levenberg-Marquardt Back propagation algorithm.

The Bayesian regularization results exhibit flexibility to model the network architecture. Thus, for the hidden layer, we set a fixed number of nodes and we used just one hidden layer due to the length of the time series. However, we observed that an extra layer did not significantly change the results. With respect to the output layer, one node is used because the forecast is one-step-ahead. The selection of the adequate number of input nodes or lags will be explained in the NAR-NN results section. In order to improve the generalization of the network, the methodology usually requires one to divide the data into three sets:

training, validation, and testing. However, Bayesian regularization avoids the validation stage because the solution is based on the optimization of equation (3).

Moreover, we employed the hyperbolic Tangent Sigmoid as an activation function for the nodes in the hidden layer as shown below. This function is frequently used in forecasting.

$$a = \frac{e^n - e^{-n}}{e^n + e^{-n}} \quad (9)$$

$$a = n \quad (10)$$

For the output layer the linear function is used.¹¹

The final architecture in matrix notations and scalar is:

$$Y_{t+1} = \mathbf{f}^2 \left(\mathbf{W}^2 \mathbf{f}^1 \left(\mathbf{W}^1 [Y_t, Y_{t-1}, \dots, Y_{t-p}] + \mathbf{b}^1 \right) + \mathbf{b}^2 \right)$$

$$y_{t+1} = \sum_{j=1}^{10} w_j^2 \mathbf{f}_j^1 \left(\sum_{i=0}^p w_{i+p}^1 Y_{t+i-p} + b^1 \right) + b^2$$

$$p^n = \frac{2(p-p^{min})}{(p^{max} - p^{min})} - 1 \quad (11)$$

where w_{i+p}^1 , $i = 1, \dots, p$, w_j^2 , $i = 1, \dots, p$ are the weights of the output layer, b^1 is the biases of the first layer, and b^2 the biases of the second layer.

Figure 7 displays the observed data (black line), the fit in the training set (blue line), the forecasts in horizons 1 and 2 (green and orange lines, respectively), and the out-of-sample forecasts eight steps ahead (yellow line). Also, the figure is divided into three blocks. The block on the left corresponds to the training set from Q31991 to Q2 2014; the center block corresponds to the testing set from Q3 2014 to Q2 2016, which occurs after the oil shock period, and the right block is the forecasting period.

¹¹ Notice that before training the network, data normalization, which transforms the data in the interval between [-1, 1], is required to make the training algorithm faster.

Figure 7. Data Block Division and Out-of-Sample Sets

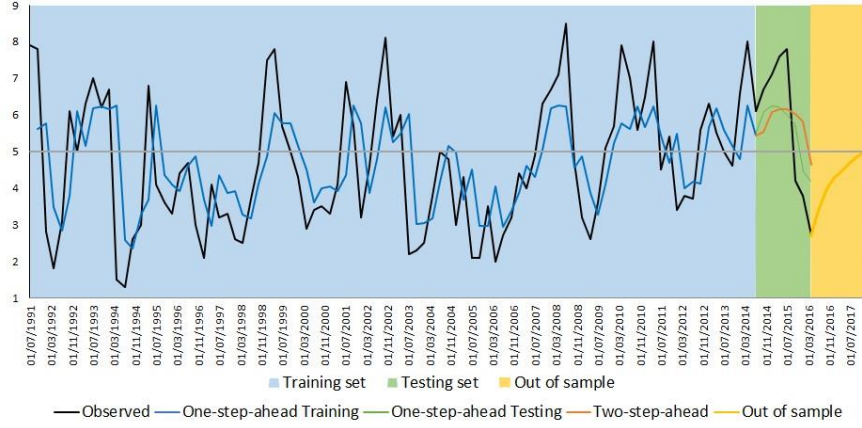

3.4 ARIMA

Box and Jenkins proposed the ARIMA model in 1970 (Box et al., 2016). The general expression of an ARIMA model is the following:

$$Y_t = \frac{\Theta_s(L^s)\theta(L)}{\Phi_s(L^s)\phi(L)\Delta_s^D\Delta^d} \varepsilon_t \quad (12)$$

where $\Theta_s(L^s) = (1 - \Theta_s L^s - \Theta_{2s} L^{2s} - \Theta_{3s} L^{3s} - \dots - \Theta_{Qs} L^{Qs})$ is a seasonal moving average polynomial, $\Phi_s(L^s) = 1 - \Phi_s L^s - \Phi_{2s} L^{2s} - \dots - \Phi_{3s} L^{3s}$ is the seasonal auto-regressive polynomial, $\theta(L) = (1 - \theta_1 L_1 - \theta_2 L_2 - \dots - \theta_q L_q)$ is the regular moving average polynomial, and $\phi(L) = (1 - \varphi_1 L^1 - \varphi_2 L^2 - \dots - \varphi_p L^p)$ is a regular auto-regressive polynomial, Δ_s^D is the seasonal difference operator, Δ^d is the difference operator, s is the periodicity of the considered series ($s = 4$ for quarterly data), and ε_t is the innovation which is assumed to represent white noise.¹²

4. Results

In this section, we present the main results of the clustering and forecasting for inflation expectations across countries. First, we present the SOM analysis that includes three sequential steps: the choice of the map topology based on data, the training and validation stages of the SOM neural network, and the elaboration of the clustering map of agent expectations (in Appendix B we include a detailed explanation of these steps). Then we

¹² The ARIMA models chosen are described in Appendix D.

overlap agents' inflation expectations on the resulting SOM map. Finally, the NAR-NN results are provided.

4.1 Self-Organizing Maps of Agents' Expectations

In this subsection, we briefly describe technical details on the implementation of the SOM analysis. We set a 10x10 hexagonal map with a learning rate varying from 0.05 to 0.0001, and we used 1,000 iterations. The computation was accomplished by the Kohonen package in R developed by Wehrens and Buydens (2007). The training step used observations before the oil shock identified on Q2 2014 and it covers a sample of 84 observations per country for the expected situation by the end of the next six months of the overall economy, capital expenditures, private consumption, and inflation.¹³

A key tool in this analysis is *the feature map or heat map* that is the representation of a single variable across the map (Figure 6). In this application, the colors identify the intensity of the indicator. For example: while the blue color is associated with low expectations, the red is associated with high expectations. Clustering can be performed by using hierarchical clustering on the weight learned vectors of the variable. This procedure requires one to set the number of clusters. Thus, given the nature of the expectations, we choose three clusters to represent low, neutral, and high expectations.

¹³ Appendix B explains the choice of topology as well as the post-training analysis of the results.

Figure 8. SOMs of Countries' Economy Situation Expectations for the Next Six Months (Q3 1991 to Q4 2014)

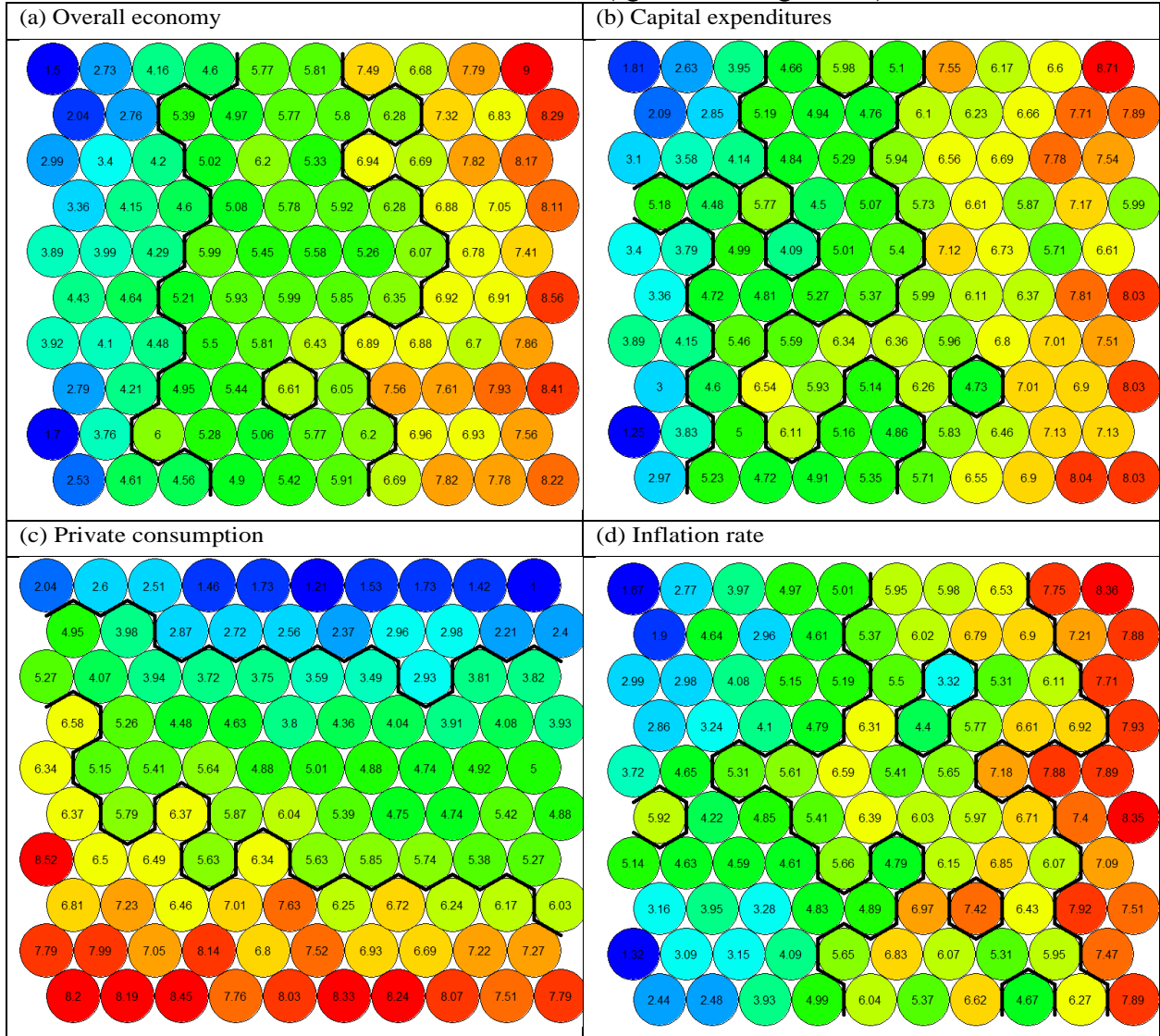

4.2 Overlapping Agents' Inflation Expectations by Country

In order to categorize agents' inflation expectation patterns after the oil price shock that took place on June 2014, we overlap those expectations from the third quarter of 2014 with the second quarter of 2016 on the resulting heatmap. Next, we classified the expectations patterns by country into two categories: smooth and brisk expectation trajectories. For smooth transitions, we expected to find a path that moves through a single cluster. Otherwise, we identify a brisk trajectory by observing a changing path among

several clusters. In Figure 9, the black arrow represents the trajectory of the inflation expectation with the initial node marked by a black start symbol.

For instance, in the case of Colombia, Figure 9(b), the observed inflation expectations for July 2014 are in the higher expectation cluster, then move through the heatmap ending in the lower expectation cluster. We classified this pattern as one of brisk expectations. Conversely, for the United Kingdom in Figure 9(d), inflation expectations vary only between two clusters. Thus, it can be categorized into the group with a smooth pattern. Table 5 summarizes the classification results for our sample of countries. From this table it is plausible that changes in expectations in countries heavily dependent on oil revenues were brisk, as exemplified by Colombia and Canada. However, in countries such as Mexico, the change in expectations is smooth because this economy is much more diversified. However, we should consider that each country faces global and idiosyncratic shocks that could have produced this heterogeneity as well.

Figure 9. Countries' Inflation Rate Next Six Months (Q3 III.2014 to Q2 2016) on the Expected Inflation Rate SOM Map

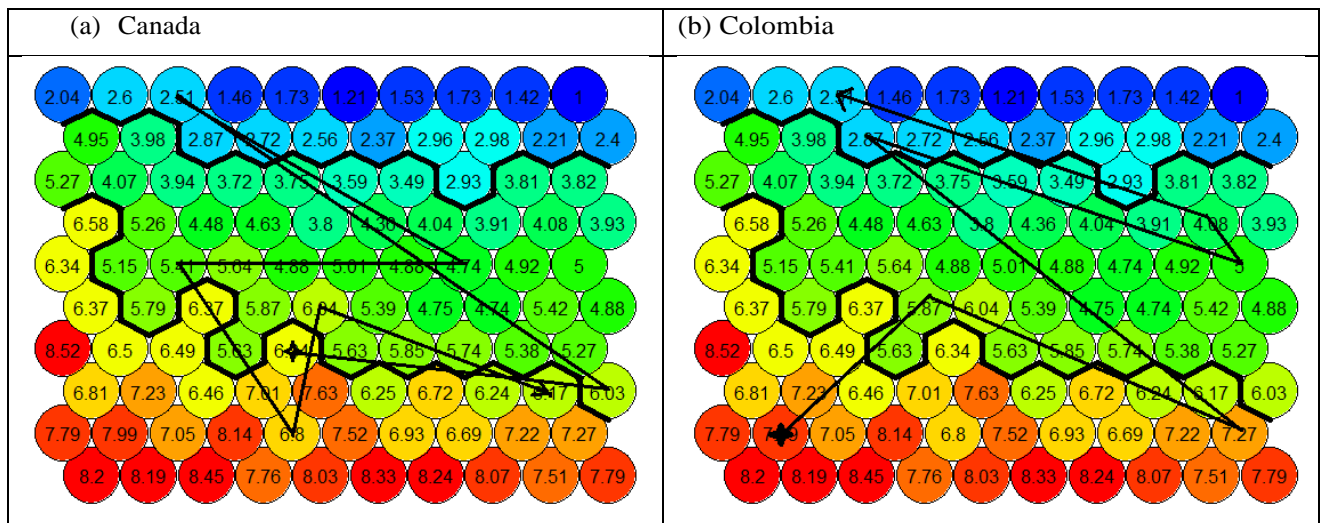

Figure 9, continued

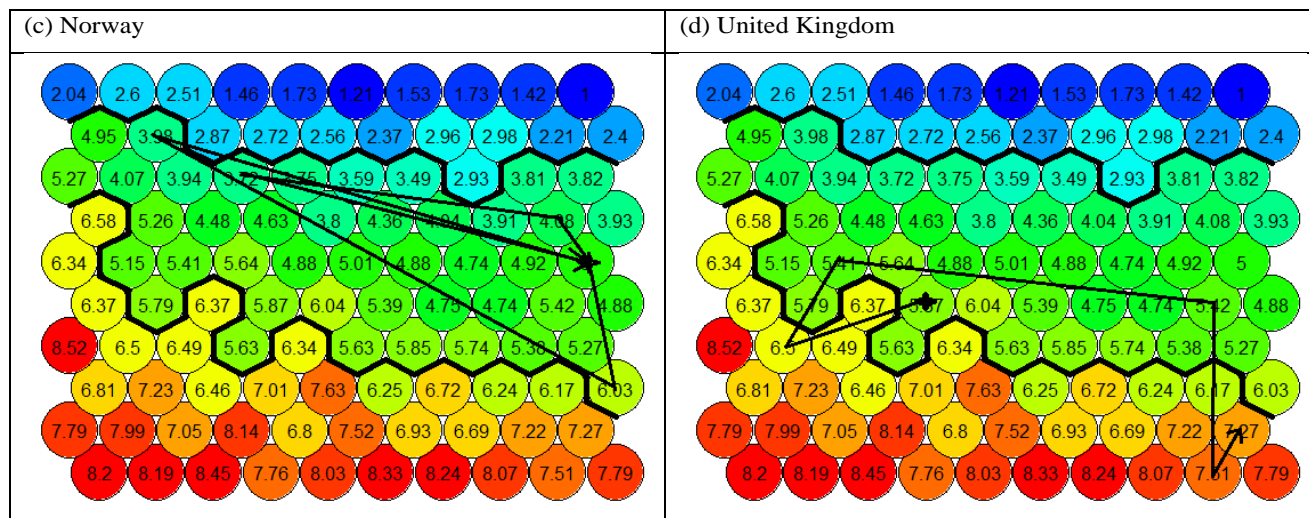

Table 5. Classification of Inflation Expectations and Lag Selected in the NAR-NN Model

Country	Inflation expectation	Lag selected
Brazil	Brisk	1
Canada	Brisk	8
Chile	Smooth	4
Colombia	Brisk	5
Czech R.	Smooth	6
Korea R.	Smooth	2
Mexico	Smooth	6
Norway	Smooth	1
Switzerland	Brisk	8
United K.	Smooth	6
Hungary	Smooth	10
Philippines.	Brisk	1
Poland	Smooth	7
Sweden	Smooth	1
Thailand.	Brisk	4
S. Africa	Brisk	1

4.3 Non-Linear Auto-Regressive Neural Network Results

We have to select a model M to apply the Bayesian regulation framework to the NAR-NN in order to improve its generalization ability. For each country, the sum of the parameters is conditional on the complexity of the data. In this context, we chose a flexible network where regularization guarantees the minimum sum of parameters. Thus, we set an architecture with one hidden layer of 10 neurons. Moreover, at the input layer we have to specify the number of neurons that correspond to the lag order used to forecast one step ahead. We used the Neural Network Toolbox (Hagan, Demuth and Beale, 2002).

The lag order selection was based on different criteria: the mean squared error resulting from the testing data, the error auto-correlation function, and the cross-correlation between the errors and the observed data. In this way, from lags 1 to 10 we generated 30 neural networks per lag and obtain the MSE for the training, testing, and the complete sample. Then, we select the lag that reports the smallest median from the testing data sample, considering the auto-correlation diagnostics.¹⁴ The lags chosen for each country are presented in Table 5, and the overall results from lags 1 to 10 are shown in Table 6.¹⁵ A similar procedure was developed by Ruiz et al. (2016). Next, we present the forecast results for some selected countries.^{16,17,18}

¹⁴ In most of the cases mean and median, of the lag chosen, are both the smallest. However, in Colombia, Czech Republic and Switzerland this is not the case, even though the lag's mean is closer to the smallest mean.

¹⁵ These results for all datasets and training sets are presented in Tables 12 and 13, respectively, in Appendix 3.

¹⁶ To see the other countries, see Figure 24 in Appendix C.

¹⁷ A summary of results of the neural networks parameters is presented in Table 14 in Appendix 3.

¹⁸ A simulation of 1000 networks was performed to ensure that the MSE presented belongs to the average neural network find after specifying the model previously described. See Table 15 and Appendix 3.

Table 6. Lag Statistics Test Data, One Step-Ahead Forecast (sample = 30)

Countries	Lags	1	2	3	4	5	6	7	8	9	10
Brazil	mean	1.65	2.08	1.85	1.86	1.89	1.85	1.83	1.84	1.92	2.04
	median	1.57	2.07	1.85	1.86	1.83	1.85	1.83	1.84	1.92	2.04
Canada	mean	2.04	1.84	1.59	1.63	1.62	1.54	1.56	1.52	1.75	1.73
	median	2.04	1.74	1.59	1.63	1.62	1.54	1.56	1.52	1.75	1.73
Switzerland	mean	1.32	1.21	1.04	1.04	1.02	0.98	1.06	0.79	0.93	0.78
	median	1.30	1.22	1.04	1.04	1.02	0.98	1.06	0.78	0.94	0.83
Chile	mean	4.34	2.76	2.77	2.70	2.74	2.80	2.94	3.13	3.13	2.93
	median	4.38	2.76	2.79	2.68	2.76	2.81	3.00	3.06	3.13	2.91
Colombia	mean	4.82	2.88	2.91	2.90	2.83	2.88	2.86	3.27	3.21	3.27
	median	4.94	2.88	2.92	2.88	2.78	2.83	2.81	3.23	3.15	3.20
Czech R.	mean	0.72	0.74	0.73	0.70	0.93	0.68	1.20	1.24	2.18	1.46
	median	0.73	0.74	0.73	0.70	0.93	0.67	1.20	1.24	2.10	1.15
United K.	mean	0.87	0.87	0.95	0.95	0.88	0.82	0.85	1.14	0.87	0.86
	median	0.87	0.86	0.95	0.95	0.88	0.82	0.83	0.84	0.87	0.83
Korea R.	mean	2.24	1.87	1.99	2.02	2.03	2.21	2.40	2.06	2.11	2.09
	median	2.21	1.86	1.99	2.02	2.03	2.21	2.40	2.06	2.06	2.05
Mexico	mean	0.38	0.42	0.52	0.48	0.48	0.31	0.50	0.36	0.45	1.07
	median	0.38	0.42	0.52	0.49	0.48	0.30	0.57	0.37	0.31	0.53
Norway	mean	1.41	1.44	1.61	1.67	1.59	2.01	2.04	2.10	1.88	1.80
	median	1.41	1.44	1.61	1.67	1.59	2.01	2.04	2.10	1.88	1.80
Hungary	mean	3.49	2.92	2.94	3.47	3.75	3.54	3.73	3.46	2.87	2.77
	median	3.52	2.91	2.94	3.47	3.71	3.54	3.73	3.46	2.86	2.75
Philippines	mean	3.41	3.99	3.86	3.78	3.78	3.83	3.47	3.60	4.14	3.65
	median	3.41	3.99	3.86	3.78	3.78	3.83	3.47	3.60	4.05	3.45
Poland	mean	1.12	1.02	1.04	1.07	1.37	1.07	0.72	0.87	3.52	7.12
	median	1.12	1.04	1.01	1.06	1.37	1.07	0.72	0.86	2.99	7.12
Sweden	mean	1.09	1.59	1.52	1.58	1.68	1.74	1.72	1.73	1.74	1.67
	median	1.10	1.59	1.52	1.58	1.68	1.74	1.72	1.72	1.74	1.67
Thailand	mean	1.67	1.01	1.03	0.90	0.95	1.00	1.06	1.10	1.05	1.02
	median	1.68	1.01	1.03	0.91	0.95	1.00	1.06	1.10	1.05	1.01
South A.	mean	2.63	3.31	3.48	3.56	3.97	3.85	4.27	4.51	4.59	4.64
	median	2.63	3.31	3.48	3.56	3.97	3.85	4.11	4.51	4.59	4.97

Figure 10. Forecasts of Inflation Expectations Using the NAR-NN Model

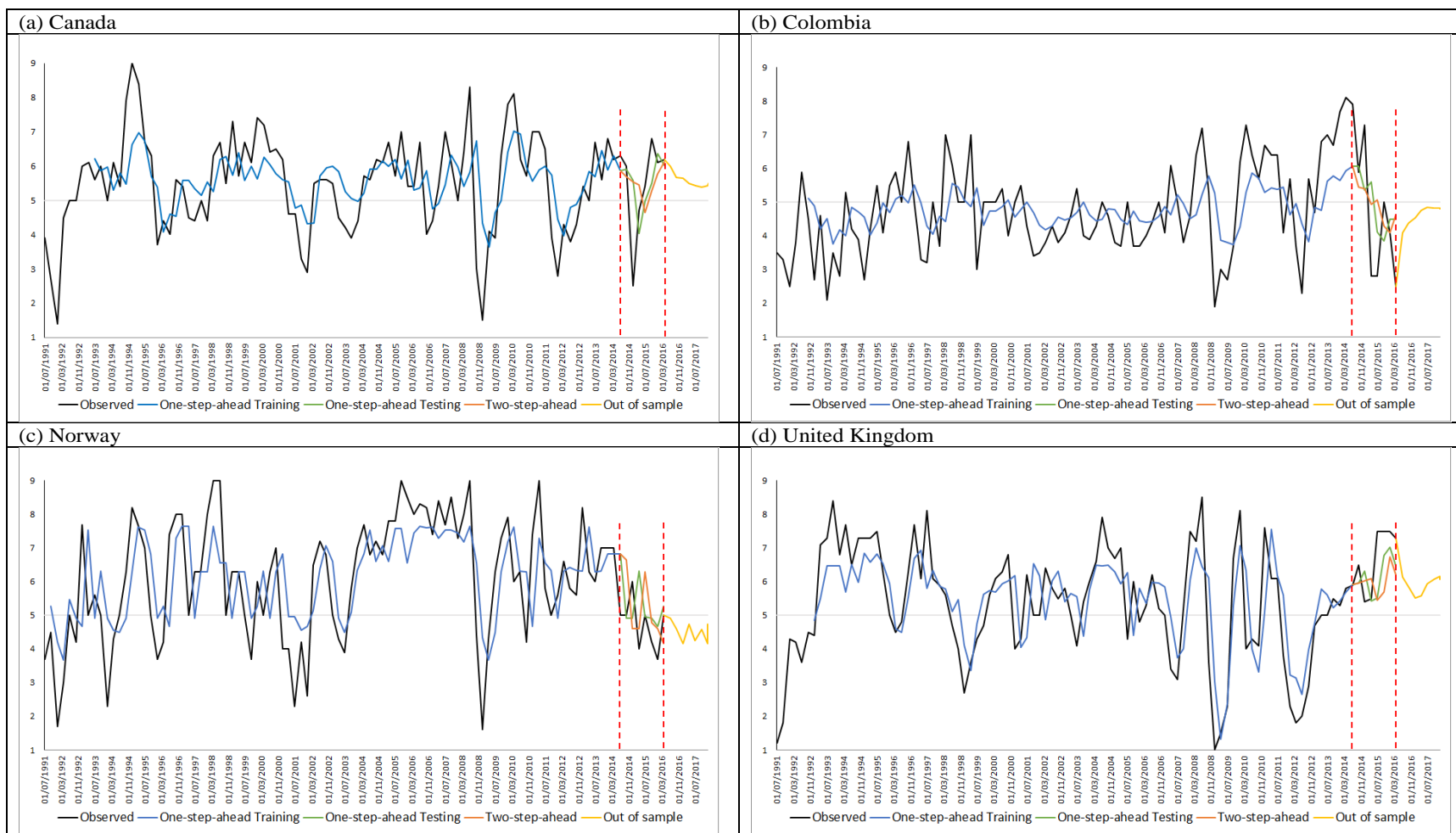

4.4 Forecast Accuracy

Table 7. MSE Comparison at Testing Data Sets for Countries with Brisk Inflation Expectations

Testing set Countries	Arima		NAR		Diebold	
	One-step ahead	Testing set Two-step ahead	Testing set One-step ahead	Testing set Two-step ahead	Mariano test One-step ahead	Mariano test Two-step ahead
Brazil	1.909	3.408	1.470	2.616	-0.988	-1.252
Canada	1.732	2.173	1.519	1.834	-1.402	-2.097
Colombia	2.913	2.926	2.776	2.648	-0.467	-1.763
Philippines	3.052	3.223	3.435	4.291	0.751	2.426
South A.	3.892	6.929	2.580	6.045	-1.571	-0.448
Switzerland	0.894	1.136	0.781	1.414	-0.343	1.041
Thailand	0.797	0.885	0.914	1.041	0.519	0.555
Brisk	2.018	2.961	1.734	2.632	-0.693	-0.702

Testing set Countries	Arima		NAR		Diebold	
	One-step ahead	Testing set Two-step ahead	Testing set One-step ahead	Testing set Two-step ahead	Mariano test One-step ahead	Mariano test Two-step ahead
Chile	3.577	4.181	2.680	2.429	-1.349	-2.539
Czech R	0.918	2.230	0.665	1.464	-0.763	-1.080
Hungary	3.485	6.850	2.746	4.734	-1.380	-1.610
Korea	1.764	2.812	1.857	3.028	2.870	8.936
Mexico	0.279	0.474	0.299	0.341	0.215	-0.945
Norway	1.484	2.019	1.419	1.221	-0.248	-1.043
Poland	1.028	2.263	0.716	0.925	-1.296	-3.950
Sweden	1.822	2.467	0.905	0.913	-2.087	-2.183
United K.	0.947	2.101	0.820	1.465	-0.945	-1.510
Soft	1.205		2.121.043	1.544	-0.033	

5. Conclusions

Evaluating and forecasting inflation expectations from international surveys of economics experts can be valuable for monetary macroeconomic modeling. In this research, we set two goals. First, we analyzed WES inflation expectations data for 16 countries that adopted inflation targeting regimes as the basis of their monetary policy. Given that the quarterly questions on the evolution of prices in these surveys consider both qualitative and quantitative scales, we used a descriptive analysis for the relationship between inflation expectations and observed inflation, and we study the structure of the in-sample forecasting errors.

Second, we generated-out-of-sample forecasts for the inflation expectations of the countries by relying on a two-step approach to sequentially cluster and forecast inflation expectations. Thus, the clustering technique known as Self-Organizing Maps and a predictive model based on artificial neural networks allow us to visualize and predict different patterns

of inflation expectations according to their perceptions before the oil shock that took place in the middle of 2014.

We cluster the countries according to the evolution of their inflation expectations during the transition period to the recent minimum oil price mark. Then, we obtain forecasts of survey expectations by using linear and non-linear NAR-NN methods. For the SOM analysis, we find that some countries exhibited brisk behavior that is associated with signs that inflation expectations were de-anchoring. At the same time, there were countries with a soft evolution of inflation expectations.

The correlation analysis from the time and frequency domain indicates the existence of different patterns of linear associations over time and frequency: increasing, descending, and inverted U- shaped. Moreover, the highest coherence between inflation and expectations were found mainly in higher frequencies, which suggest that the relationship between inflation expectations and observed inflation is present in short duration cycles.

Concerning the statistical evaluation based on the forecasting errors of the quantitative inflation expectation, we detected uncertainty in the predictions of average annual inflation across countries that could be classified into two groups. In the first group, the closer the expert is to the end of the year, the smaller the prediction bias. This group includes Colombia and Switzerland among others. The other group of countries exhibit increasing bias in the last quarter of the prediction period and include Brazil, Canada, and Chile.

Additionally, the quality of the quantitative question is judged by standard measures of forecast evaluation at different horizons: RMSE, MAE, and U-Theil. Thus, we concluded that the forecasts meet a minimum standard compared to the random walk reference and that economic experts have made systematic errors in their predictions. Inflation was under-predicted when it was rising and over-predicted when it was declining in most of the countries. The Theil decomposition of the MSE illustrated that 83 percent of the countries experienced systematic distortion in their forecasts, which means that the increase in accuracy with shorter forecast horizons is not monotonic. The evidence does not support the claim that forecasts have improved over time due to a non-linear generating data process. The evidence also suggests that turning points of observed average inflation were mostly anticipated in most cases. This issue may be an interesting area for further research.

On the other hand, a Self-Organizing Map analysis of surveys expectations before the impending oil shock allows us to classify inflation expectations as either brisk or soft based on the speed with which expectations shift. Using this classification, we can select the most appropriate forecasting method. We notice that the low-inflation expectations cluster is relatively small compared to high and neutral clusters for inflation targeting countries. The Nonlinear auto-regressive neural network and ARIMA methods were used as competing candidates to forecast inflation expectations. The results indicate that in the one step ahead forecasts the neural network is slightly better, but in two step-ahead forecasts, it outperforms the ARIMA model significantly. For Canada, Colombia, Chile, Poland, Hungary, and Sweden in particular, the neural network produces significant improvement in the two-step ahead forecasts.

Further research is required to provide theoretical economic explanations for the results of each country. Moreover, this combination between machine learning and statistics can be implemented in a follow-up paper to forecast actual inflation.

Bibliography

- Box, G.E.P. et al. 2016. *Time Series Analysis: Forecasting and Control*. New York, United States: Wiley.
- Canova, F., and B.E. Hansen. 1995. "Are Seasonal Patterns Constant over Time? A Test for Seasonal Stability." *Journal of Business Economic Statistics* 13(3): 237-252. doi:10.1080/07350015.1995.10524598.
- Carvalho, C., and F. Nechio. 2014. "Do People Understand Monetary Policy?" *Journal of Monetary Economics* 66: 108-123.
- Claveria, O., E. Monte and S. Torra. 2016. "A Self-Organizing Map Analysis of Survey-Based Agents' Expectations before Impending Shocks for Model Selection: The Case of the 2008 Financial Crisis." *International Economics* 146: 40-58. doi: 10.1016/j.inteco.2015.11.003.
- Coibion, O. 2012. "Are the Effects of Monetary Policy Shocks Big or Small?" *American Economic Journal: Macroeconomics* 4(2): 1-32.
- Crump, R.K. et al. 2015. "Subjective Intertemporal Substitution." Federal Reserve Bank of New York Staff Reports 734. New York, United States: Federal Reserve Bank of New York.
- Dickey, D.A, and W.A. Fuller. 1981. "Likelihood Ratio Statistics for Autoregressive Time Series with a Unit Root." *Econometrica* 49(4): 10-57. doi:10.2307/1912517.
- Fildes, R., and H. Stekler. 2002. "The State of Macroeconomic Forecasting." *Journal of Macroeconomics* 24(4): 435-468. doi:10.1016/s0164-0704(02)00055-1.
- Hagan, M.T., H.B. Demuth and M.H. Beale. 2002. *Neural Network Toolbox: User's Guide*. Natick, United States: The MathWorks, Inc.
- Hagan, M.T. et al. 2014. *Neural Network Design*. Second edition. Boulder, United States: University of Colorado.
- Hamella, S., and H. Haupt. 2007. "Suitability of WES Data for Forecasting Inflation." In: G. Goldrian, editor. *Handbook of Survey-Based Business Cycle Analysis*. Cheltenham, United Kingdom: Edward Elgar.
- Henzel, S., and T. Wollmershäuser. 2008. "The New Keynesian Phillips Curve and the Role of Expectations: Evidence from the Cesifo World Economic Survey." *Economic Modelling* 25(5): 811-832. doi:10.1016/j.econmod.2007.11.010.

- Jain, A., J. Mao and K. Mohiuddin. 1996. "Artificial Neural Networks: A Tutorial." *Computer* 29(3): 31-44. doi:10.1109/2.485891.
- Kock, A.B., and T. Teräsvirta. 2016. "Forecasting Macroeconomic Variables Using Neural Network Models and Three Automated Model Selection Techniques." *Econometric Reviews* 35(8-10): 1753-1779. doi: 10.1080/07474938.2015.1035163.
- Kohonen, T. 2001. *Self-Organizing Maps*. New York, United States: Springer.
- Kwiatkowski, D. et al. 1992. "Testing the Null Hypothesis of Stationarity against the Alternative of a Unit Root." *Journal of Econometrics* 54(1-3): 159-178. doi: 10.1016/0304-4076(92)90104-y.
- Lynn, S. 2014. "Self-Organising Maps for Customer Segmentation Using R." <https://www.r-bloggers.com/self-organising-maps-for-customer-segmentation-using-r>
- Marcellino, M. 2004. "Forecasting EMU Macroeconomic Variables." *International Journal of Forecasting* 20: 359-72. doi:10.1016/j.ijforecast.2003.09.003
- Ruiz, L. et al. 2016. "An Application of Non-Linear Autoregressive Neural Networks to Predict Energy Consumption in Public Buildings." *Energies* 9(9): 1-21. 684. doi:10.3390/en9090684.
- Stangl, A. 2007a. "World Economic Survey." In: G. Goldrian, editor. *Handbook of Survey-Based Business Cycle Analysis*. Cheltenham, United Kingdom: Edward Elgar.
- Stangl, A. 2007b. "European Data Watch: Ifo World Economic Survey Micro Data." *Schmollers Jahrbuch: Journal of Applied Social Science Studies / Zeitschrift fr Wirtschafts- und Sozialwissenschaften* 127(3): 487-496. http://EconPapers.repec.org/RePEc:aeq:aeqsjb:v127_y2007_i3_q3_p487-496
- Stock, J.H., and M.W. Watson. 1998. "A Comparison of Linear and Nonlinear Univariate Models for Forecasting Macroeconomic Time Series." NBER Working Paper 6607. Cambridge, United States: National Bureau of Economic Research
- Theil, H. et al. 1975. *Applied Economic Forecasting*. Amsterdam, The Netherlands: North-Holland.
- Titterton, D.M. 2004. "Bayesian Methods for Neural Networks." *Statistical Science* 19(1): 128-139. doi:10.1214/088342304000000099.
- Wehrens, R., and L. Buydens. 2007. "Self- and Super-Organising Maps in R: The Kohonen Package." *Journal of Statistical Software* 21 (5). URL <http://www.jstatsoft.org/v21/i05>

- White, H. 1989. "Learning in Artificial Neural Networks: A Statistical Perspective." *Neural Computation* 1 (4): 425-464. doi:10.1162/neco.1989.1.4.425.
- Yuriy, Y., and C. Olivier. 2015. "Is the Phillips Curve Alive and Well after All? Inflation Expectations and the Missing Disinflation." *American Economic Journal: Macroeconomics* 7(1): 197-232. <https://ideas.repec.org/a/aea/aejmac/v7y2015i1p197-232.html>
- Zhang, G., B.E. Patuwo and M.Y. Hu. 1998. "Forecasting with Artificial Neural Networks: "The State of the Art." *International Journal of Forecasting* 14(1): 35–62.
doi: [http://doi.org/10.1016/S0169-2070\(97\)00044-7](http://doi.org/10.1016/S0169-2070(97)00044-7).
URL <http://www.sciencedirect.com/science/article/pii/S0169207097000447>

Appendix A. Data

A.1 Qualitative Series

Figure 11. Expected Inflation Rate for the Next Six Months, WES Qualitative Question

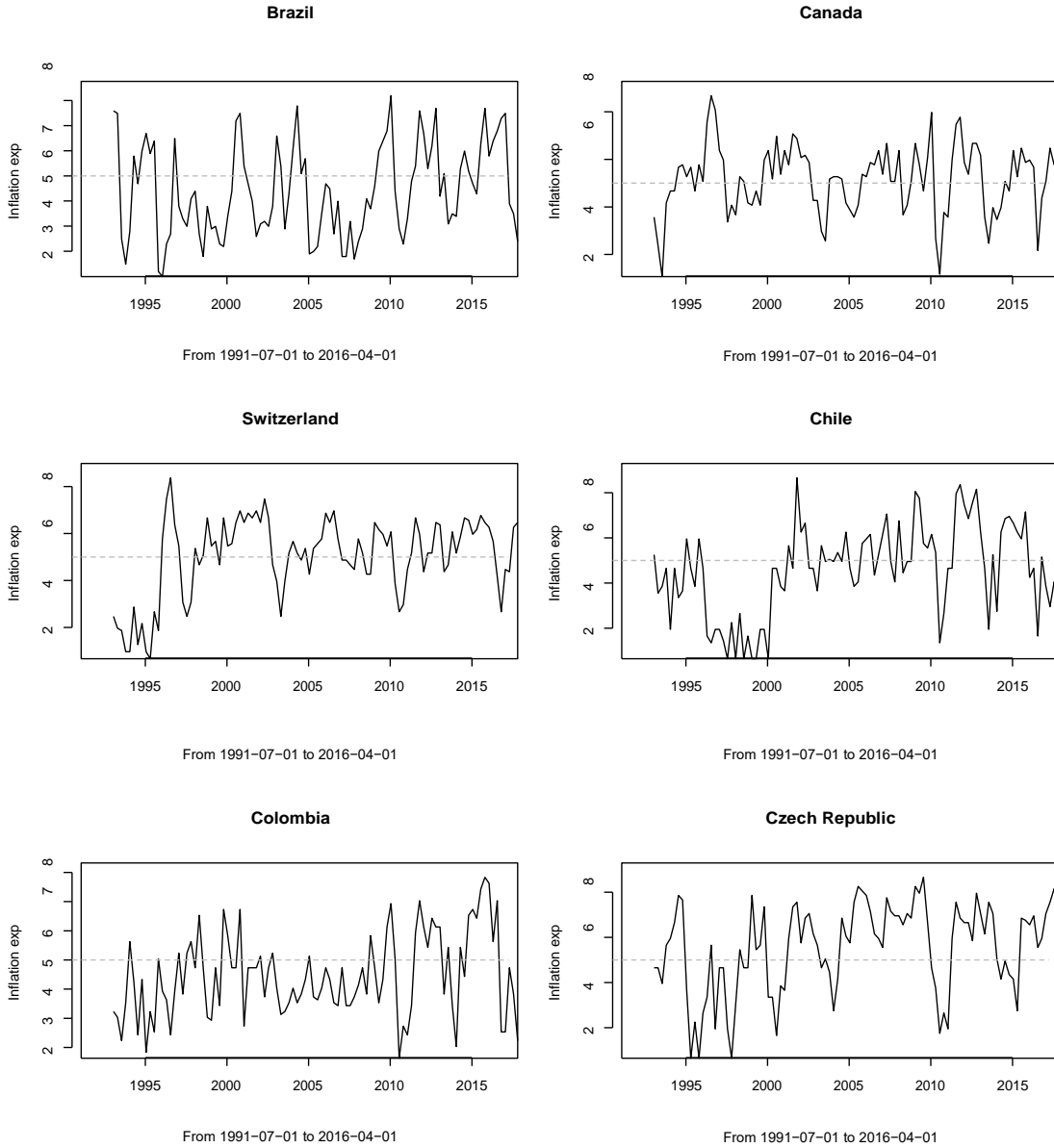

United Kingdom

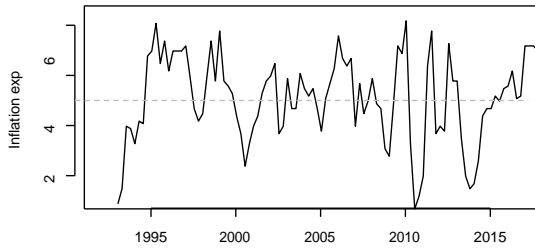

Korea

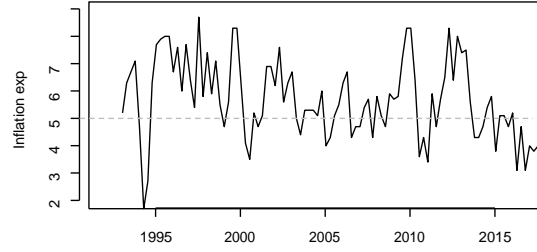

From
1991-07-01
to
2016-04-01
Mexico

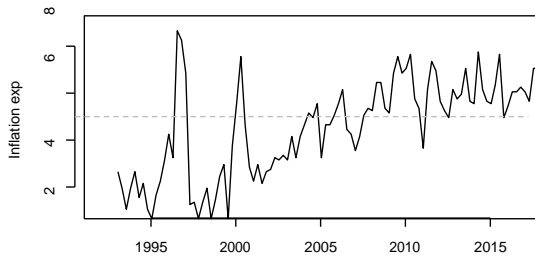

From 1991-07-01 to 2016-04-01

Norway

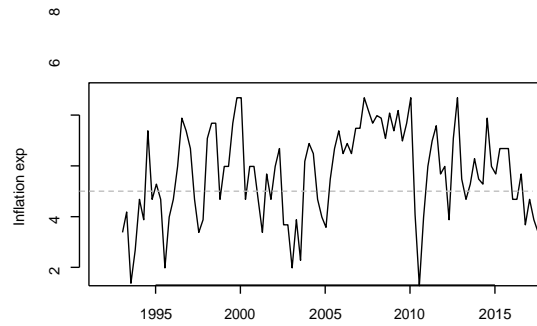

From 1991-07-01 to 2016-04-01

Hungary

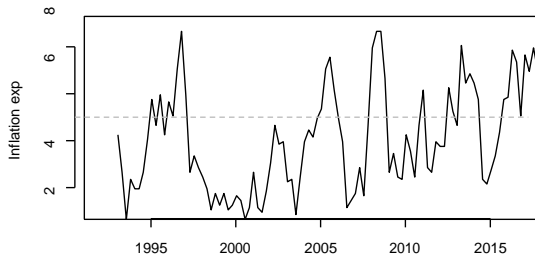

From 1991-07-01 to 2016-04-01

Philippines

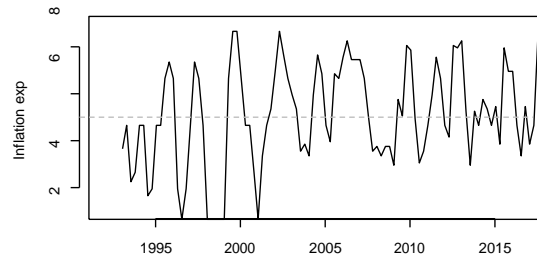

From 1991-07-01 to 2016-04-01

Poland

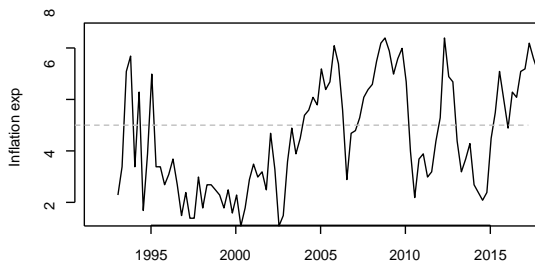

From 1991-07-01 to 2016-04-01

Sweden

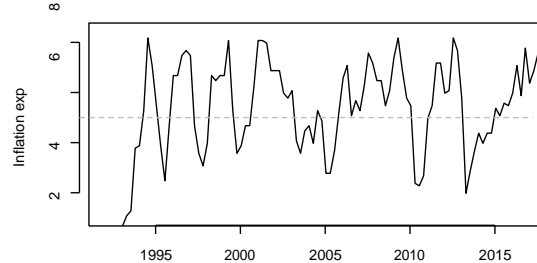

From 1991-07-01 to 2016-04-01

Figure 12. Histograms of Agents' Expectations of Economic Situation for Next Six Months in Macroeconomic Variables

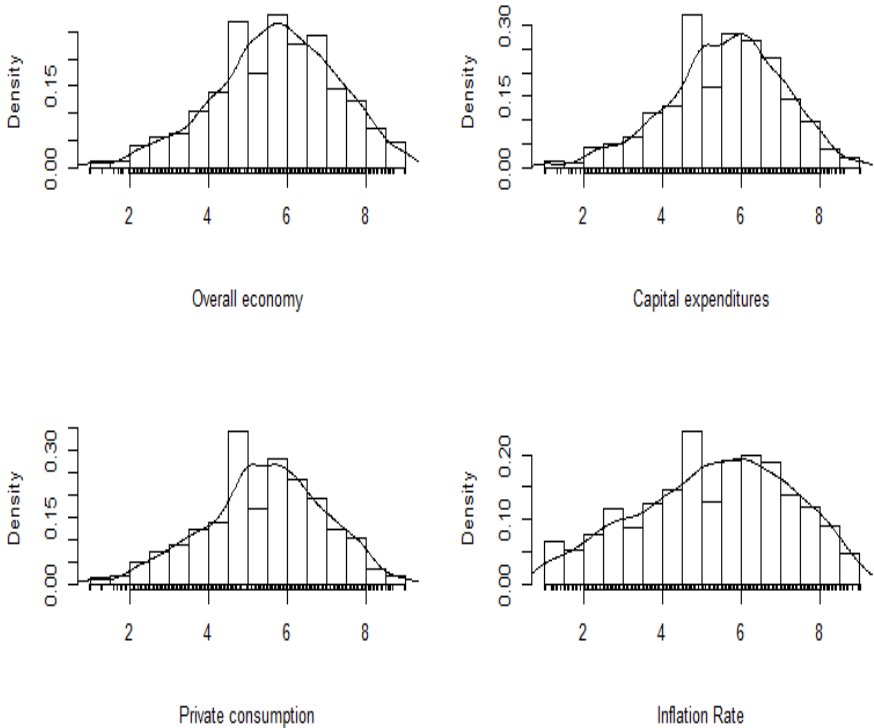
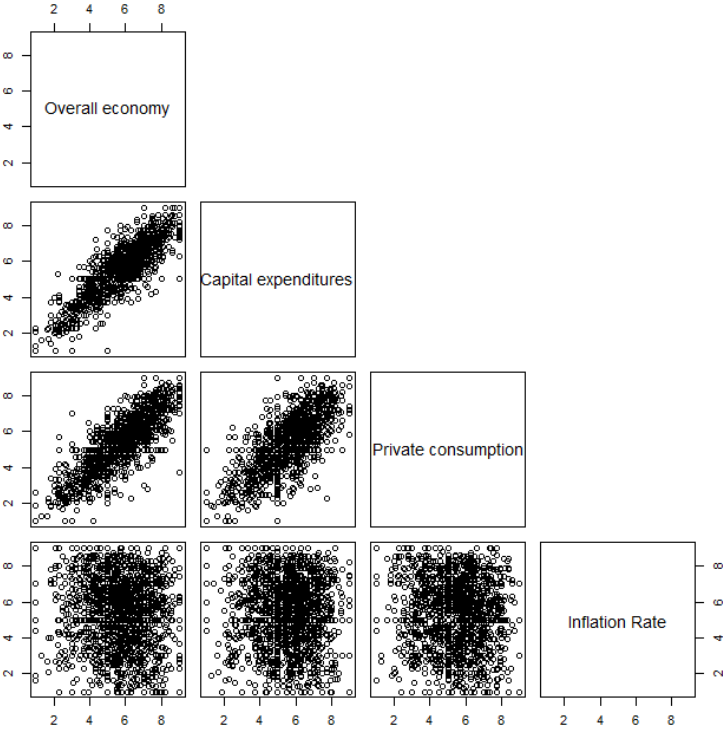

Table 9. Data Summary of WES Expectations from Q3 1991 to Q2 2016, Selected Countries

	Overall economy	Capital expenditures	Private consumption	Inflation rate
Min	1	1	1	1
1stQ	4.8	4.7	4.57	4
Median	5.8	5.7	5.5	5.5
Mean	5.79	5.59	5.44	5.32
3rdQ	6.8	6.6	6.5	6.8
Max	9	9	9	9

Figure 13. Scatter Plot of Agents' Expectations of Economic Situation for Next Six Months



A.2 WES Survey Questionnaire

Figure 14. Example of World Economic Survey (WES) Questionnaire

Ifo Institute for Economic Research				World Economic Survey WES									
Poschingerstr. 5, D-81679 München, Tel: Ms Stangl +49 (0)89 9224-1227 Telefax: +49 (0)89 985369 or +49 (0)89 9224-1463 or -2227													
The individual survey results will be treated as absolutely confidential. Please mark the appropriate boxes. No mark means: "Not applicable" or "no judgement". The answer "no change" implies no remarkable change.													
Data requested for				Code-Nr.:									
1. This country's general situation regarding				present judgement			compared to the same time last year			from now on: expected situation by the end of the next 6 months			
				good	satisfactory	bad	better	about the same	worse	better	about the same	worse	
- overall economy				<input type="checkbox"/>	<input type="checkbox"/>	<input type="checkbox"/>	<input type="checkbox"/>	<input type="checkbox"/>	<input type="checkbox"/>	<input type="checkbox"/>	<input type="checkbox"/>	<input type="checkbox"/>	
- capital expenditures				<input type="checkbox"/>	<input type="checkbox"/>	<input type="checkbox"/>	<input type="checkbox"/>	<input type="checkbox"/>	<input type="checkbox"/>	<input type="checkbox"/>	<input type="checkbox"/>	<input type="checkbox"/>	
- private consumption				<input type="checkbox"/>	<input type="checkbox"/>	<input type="checkbox"/>	<input type="checkbox"/>	<input type="checkbox"/>	<input type="checkbox"/>	<input type="checkbox"/>	<input type="checkbox"/>	<input type="checkbox"/>	
2. Expected foreign trade volume by the end of the next 6 months (in convertible currency)				higher	about the same	lower							
exports				<input type="checkbox"/>	<input type="checkbox"/>	<input type="checkbox"/>							
imports				<input type="checkbox"/>	<input type="checkbox"/>	<input type="checkbox"/>							
3. Expected trade balance within the next 6 months (in convertible currency)				improvement (a)	no change	deterioration (b)							
(a) increasing surplus or decreasing deficit				<input type="checkbox"/>	<input type="checkbox"/>	<input type="checkbox"/>							
(b) decreasing surplus or increasing deficit													
4. Expected inflation rate by the end of the next 6 months (change of consumer prices compared to the same month previous year)				higher	about the same	lower							
The rate of inflation on average of 2004 will be _____				% (p.a.)									
5. Expected interest rates by the end of the next 6 months				higher	about the same	lower							
- short term rates (3-month money market rates)				<input type="checkbox"/>	<input type="checkbox"/>	<input type="checkbox"/>							
- long-term rates (government bonds with 10 and more years of maturity)				<input type="checkbox"/>	<input type="checkbox"/>	<input type="checkbox"/>							
6. At present, in relation to this country's currency the following currencies (US \$, Euro, UK £, Yen) are...				US \$	Euro	UK	Yen						
overvalued				<input type="checkbox"/>	<input type="checkbox"/>	<input type="checkbox"/>	<input type="checkbox"/>						
about at proper value				<input type="checkbox"/>	<input type="checkbox"/>	<input type="checkbox"/>	<input type="checkbox"/>						
undervalued				<input type="checkbox"/>	<input type="checkbox"/>	<input type="checkbox"/>	<input type="checkbox"/>						
7. The value of the US \$ in relation to this country's currency by the end of the next 6 months will be				higher	about the same	lower							
				<input type="checkbox"/>	<input type="checkbox"/>	<input type="checkbox"/>							
8. The level of domestic share prices by the end of the next 6 months will be				higher	about the same	lower							
				<input type="checkbox"/>	<input type="checkbox"/>	<input type="checkbox"/>							
9. Please try to assess the importance of the following problems the economy of your country is facing at present							most important	important	not so important				
- Lack of confidence in the government's economic policy							<input type="checkbox"/>	<input type="checkbox"/>	<input type="checkbox"/>				
- Insufficient demand							<input type="checkbox"/>	<input type="checkbox"/>	<input type="checkbox"/>				
- Unemployment							<input type="checkbox"/>	<input type="checkbox"/>	<input type="checkbox"/>				
- Inflation							<input type="checkbox"/>	<input type="checkbox"/>	<input type="checkbox"/>				
- Lack of international competitiveness							<input type="checkbox"/>	<input type="checkbox"/>	<input type="checkbox"/>				
- Trade barriers to exports							<input type="checkbox"/>	<input type="checkbox"/>	<input type="checkbox"/>				
- Lack of skilled labour							<input type="checkbox"/>	<input type="checkbox"/>	<input type="checkbox"/>				
- Public deficits							<input type="checkbox"/>	<input type="checkbox"/>	<input type="checkbox"/>				
- Foreign debts							<input type="checkbox"/>	<input type="checkbox"/>	<input type="checkbox"/>				
- Capital shortage							<input type="checkbox"/>	<input type="checkbox"/>	<input type="checkbox"/>				
- Others: _____													
10. ICC Special Question The current round of multilateral trade negotiations, launched in Doha in 2001, is stalled. Leaders of the world's major industrial democracies are meeting in June 2004 at the G8 Summit in the US to discuss world trade and protectionist pressures.													
1. How important is it to your business / the economy of your country that the Doha Round gets back on track?													
very important			important			not important			no answer				
<input type="checkbox"/>			<input type="checkbox"/>			<input type="checkbox"/>			<input type="checkbox"/>				
2. How satisfied are you with the efforts of the world's political leaders to contain protectionist pressures and to promote a better understanding among electorates of the benefits of an open international trade system?													
fully satisfied			satisfied			dissatisfied			no answer				
<input type="checkbox"/>			<input type="checkbox"/>			<input type="checkbox"/>			<input type="checkbox"/>				
11. Expected growth of real Gross Domestic Product (GDP) this year in % _____													
Please return the questionnaire by April 14, 2004													

Figure 15. Countries' Inflation Expectations and Annual Inflation

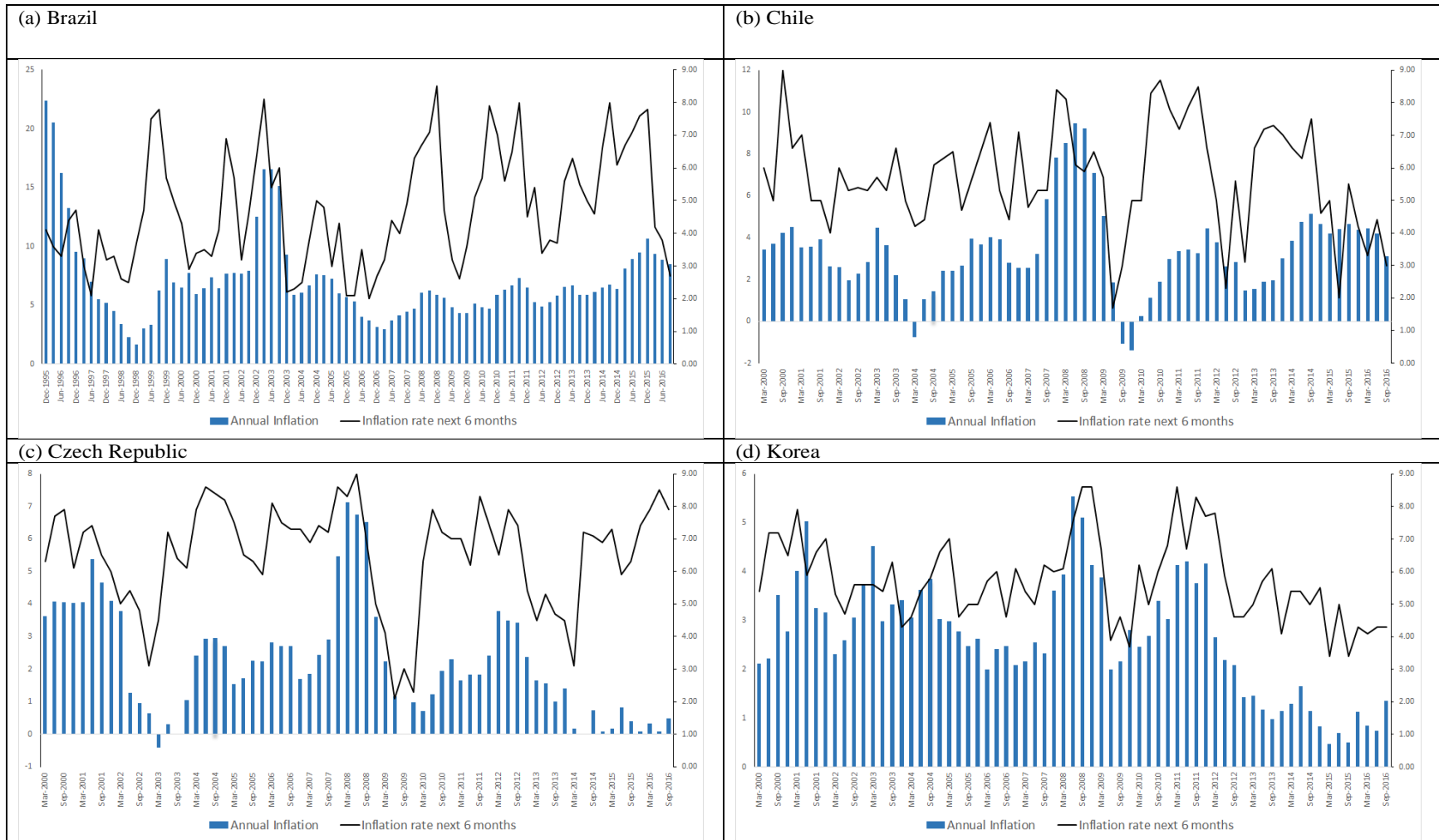

(e) Mexico

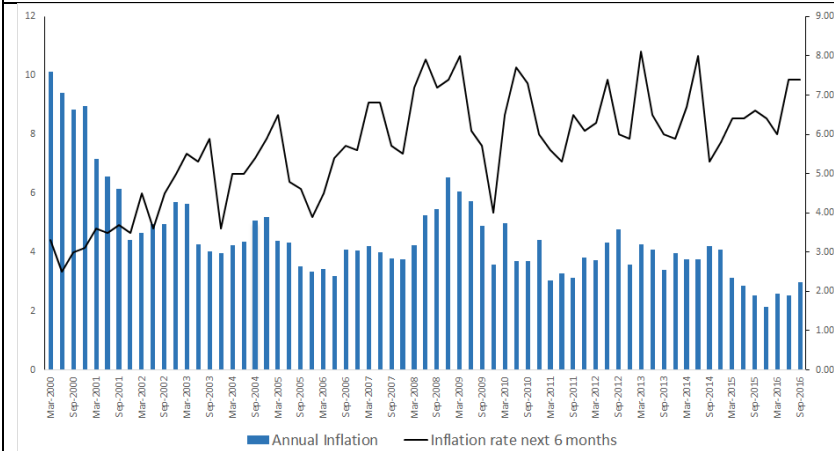

(f) Philippines

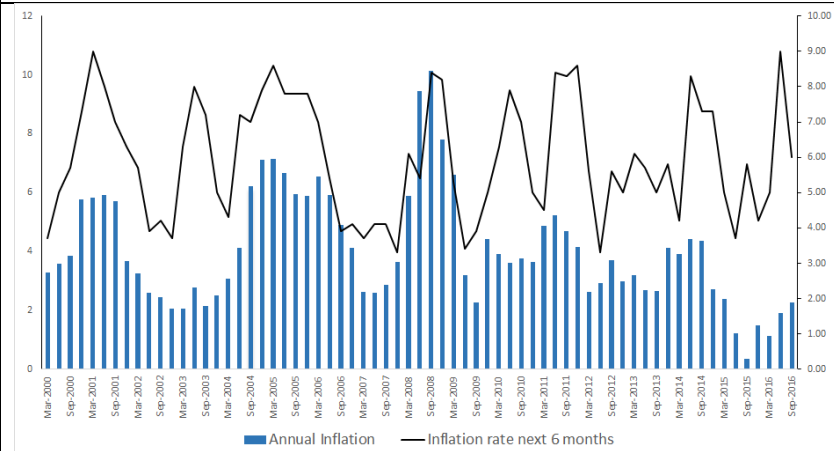

(g) Poland

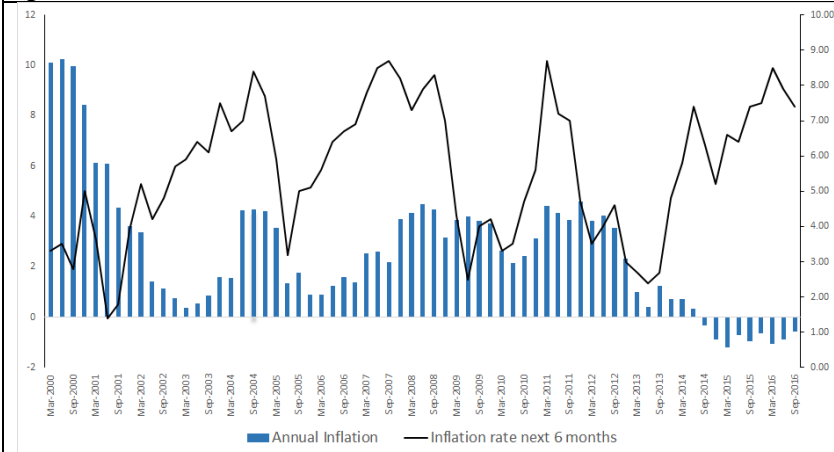

(h) South Africa

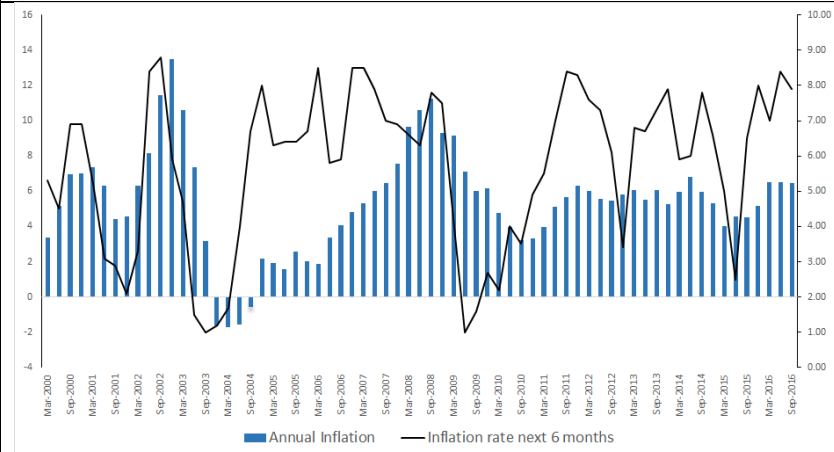

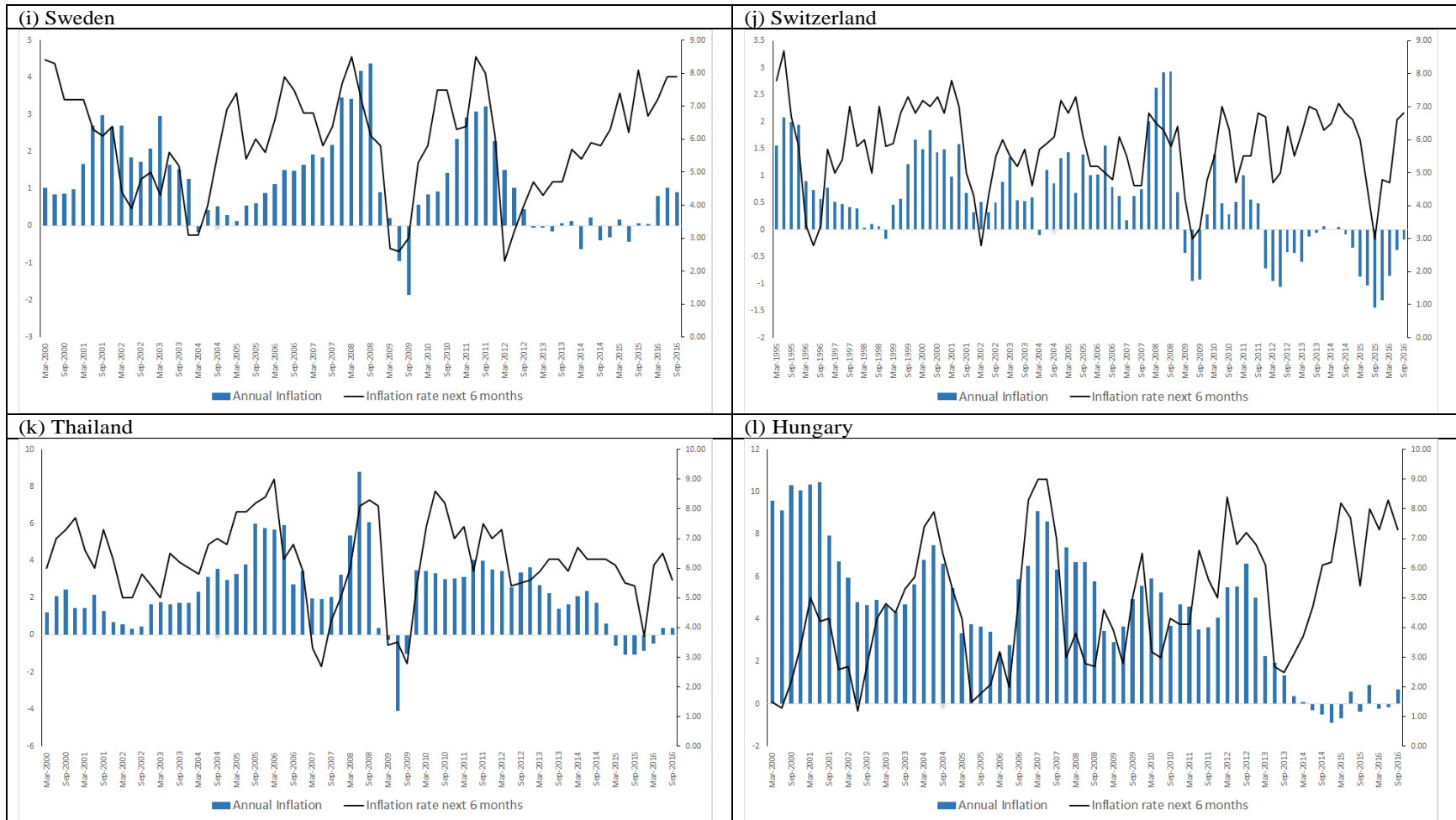

Source: WES and OECD statistics.

Figure 16. Correlation Coefficients between WES Qualitative Inflation Expectation and Annual Inflation

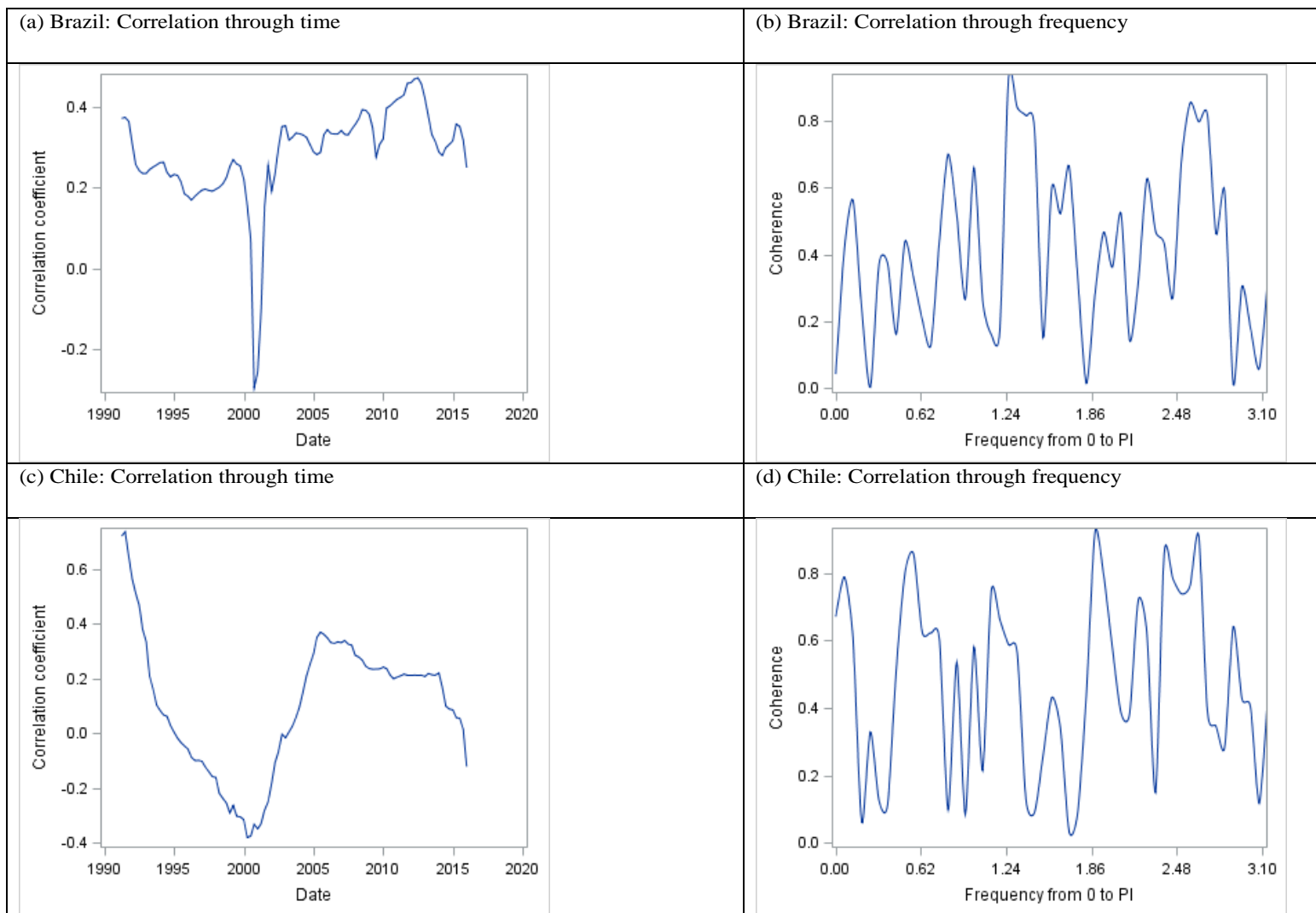

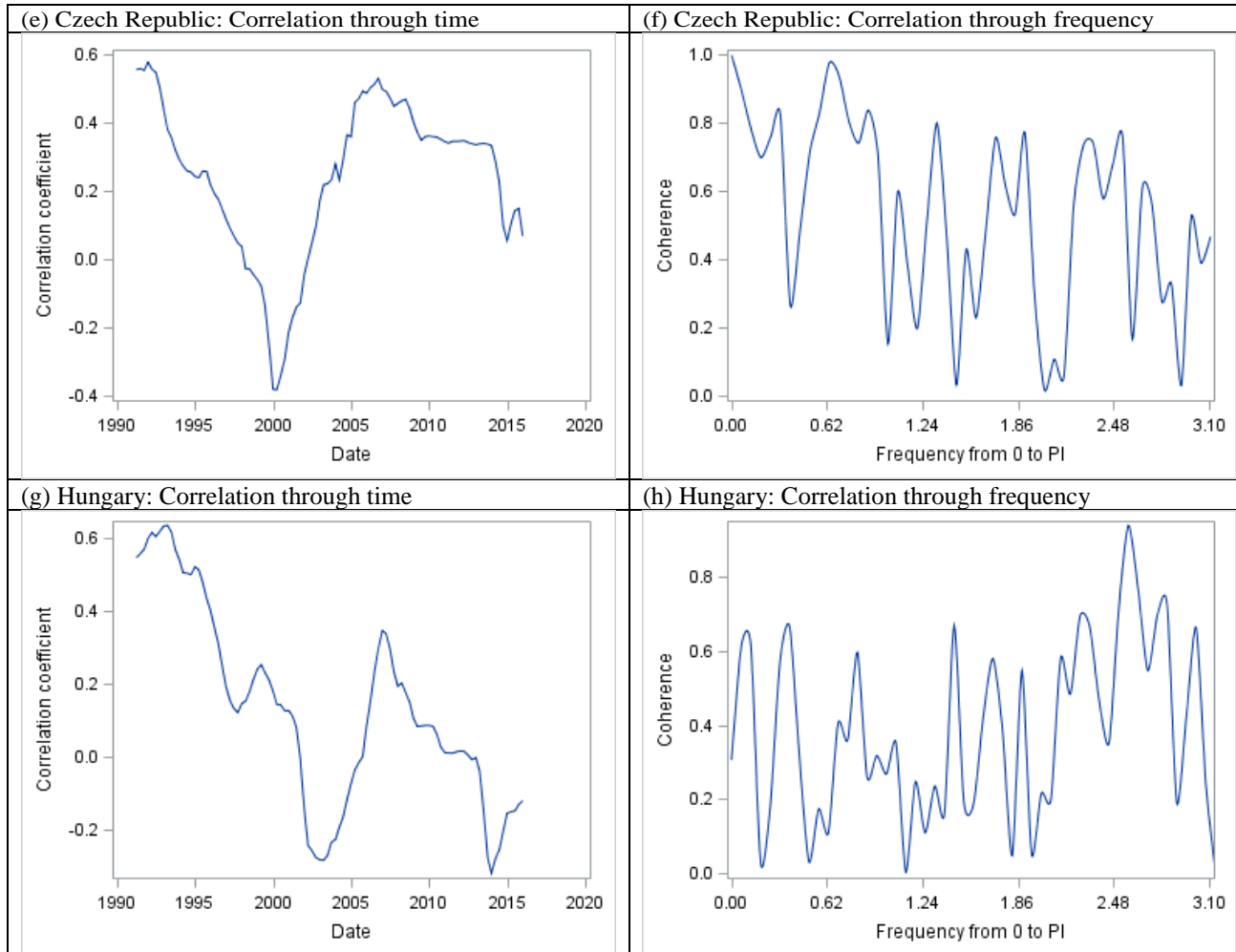

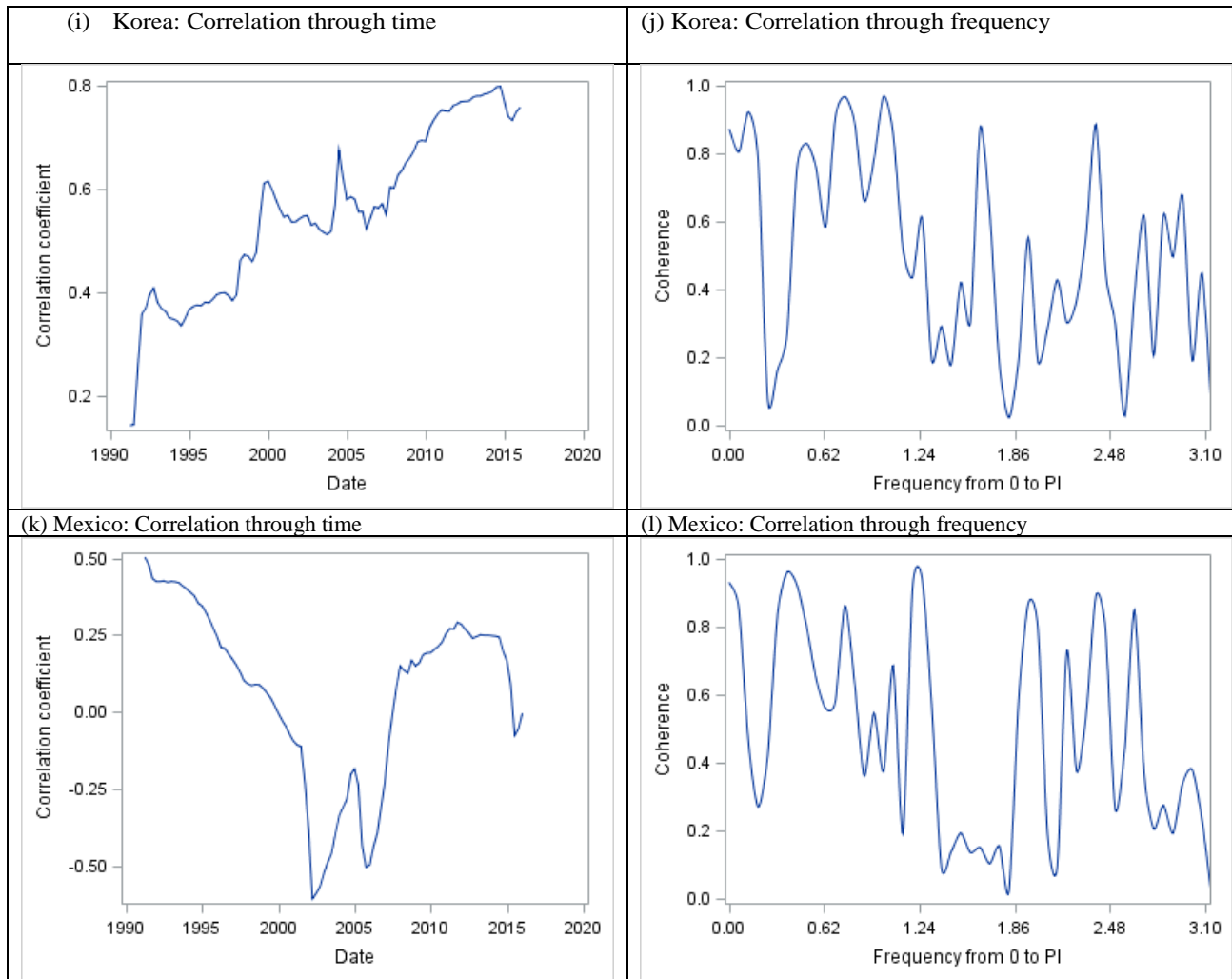

(m) Philippines: Correlation through time

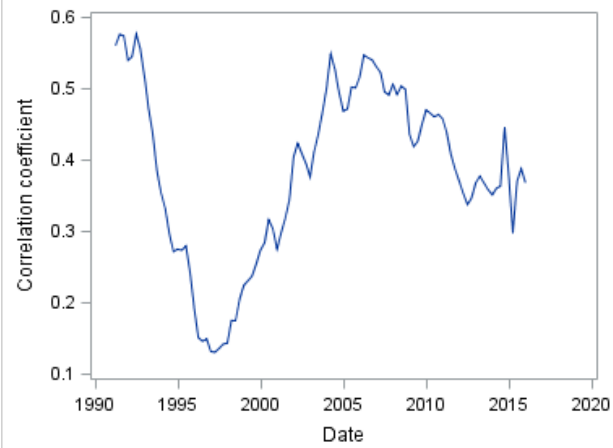

(n) Philippines: Correlation through frequency

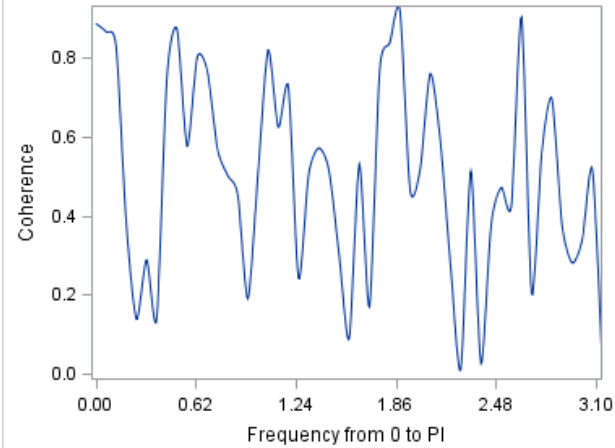

(o) Poland: Correlation through time

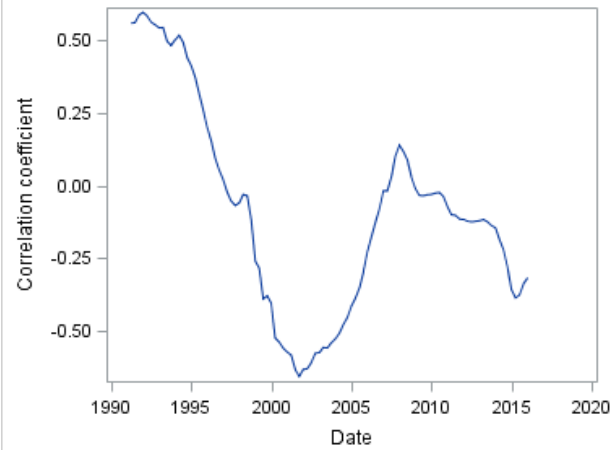

(p) Poland: Correlation through frequency

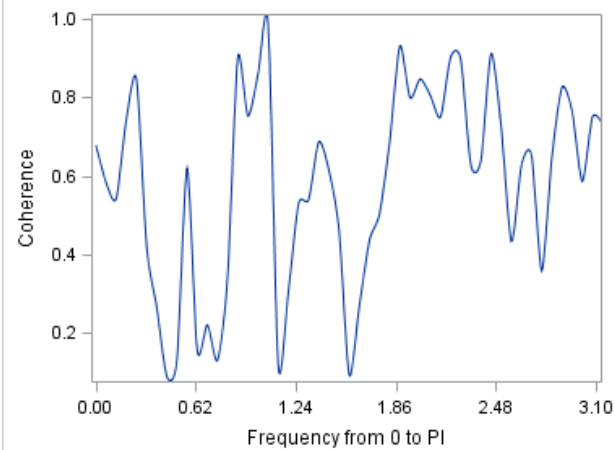

(q) South Africa: Correlation through time

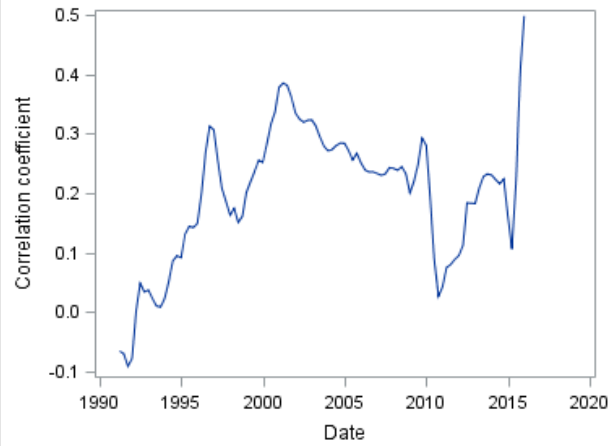

(r) South Africa: Correlation through frequency

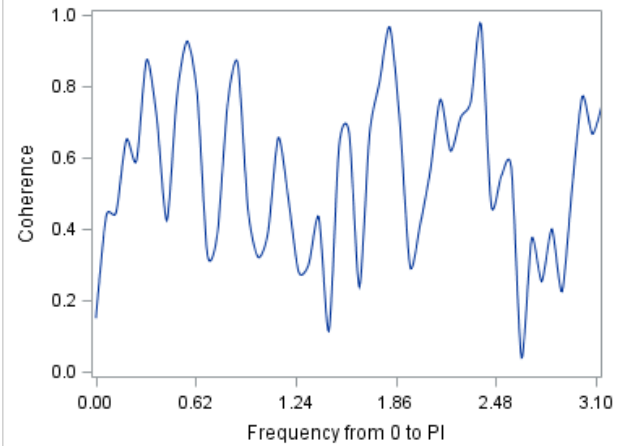

(s) Sweden: Correlation through time

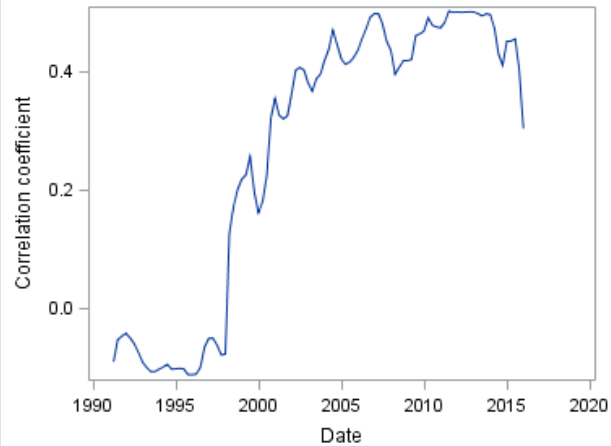

(t) Sweden: Correlation through frequency

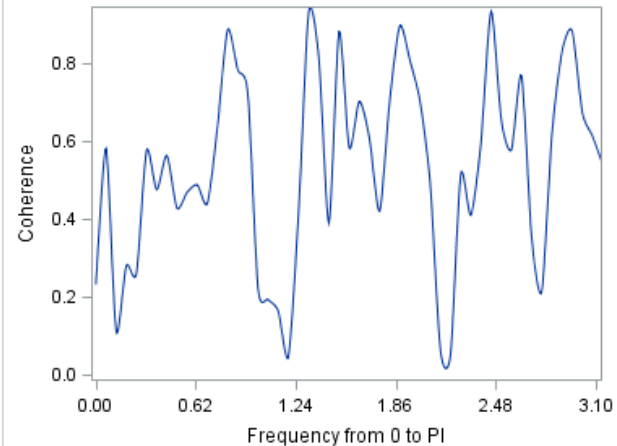

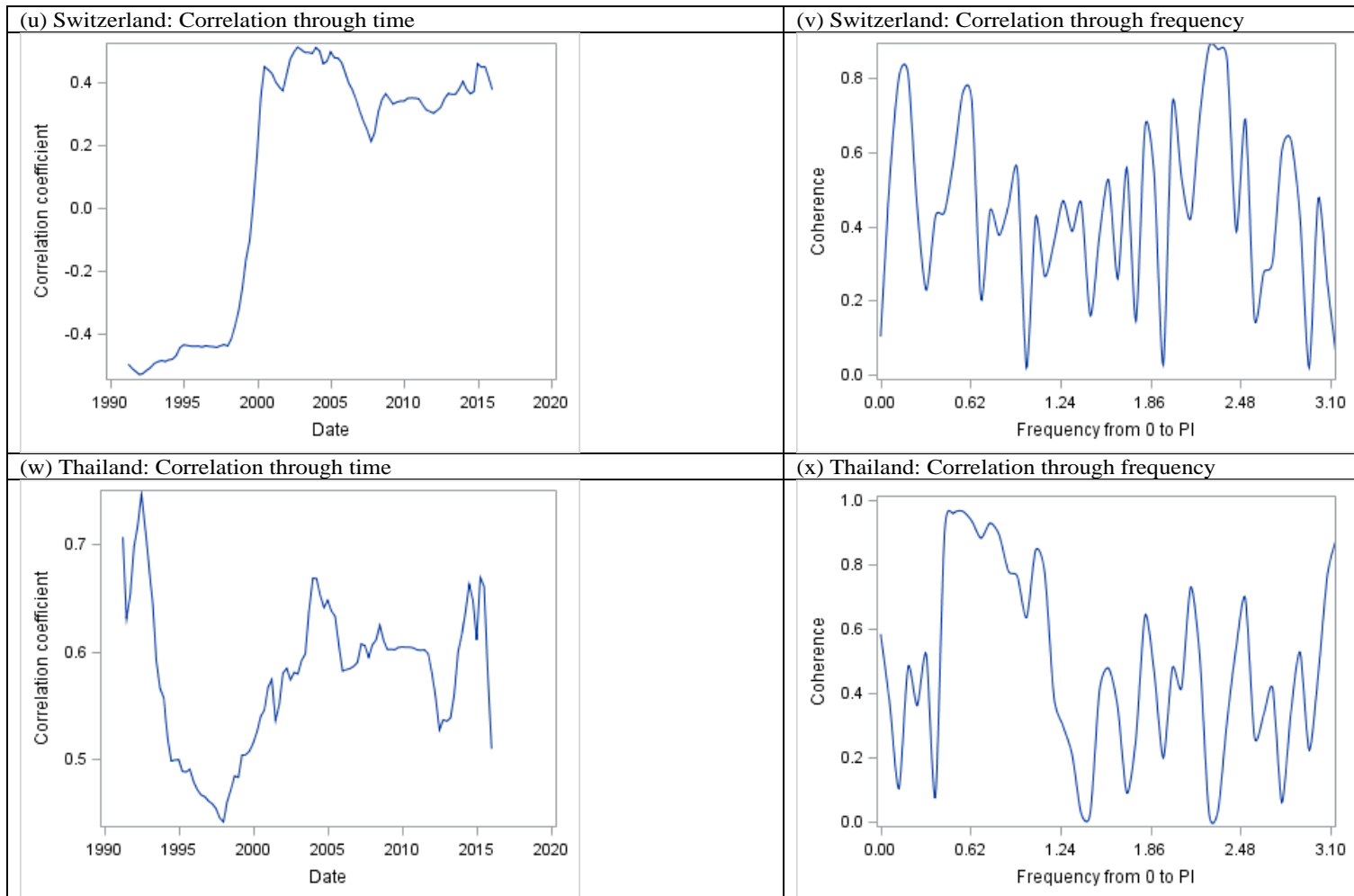

Source: WES survey, OECD statistics, and IMF data.

A.3 Quantitative Forecasting Inflation Expectations

A.3.1 Equations of the Statistical Analysis Forecasting Error

Root mean squared forecast error (RMSFE):

$$\sqrt{\frac{1}{26} \sum_{1991}^{2016} e(L, Q(h), t)^2} \quad (13)$$

Mean absolute error (MAE):

$$\frac{1}{26} \sum_{1991}^{2016} |e(L, Q(h), t)| \quad (14)$$

Theil U.statistic:

$$\frac{\sqrt{\frac{1}{26} \sum_{1991}^{2016} e(L, Q(h), t)^2}}{\sqrt{\frac{1}{26} \sum_{1991}^{2016} q(L, Q(h), t)^2} \sqrt{\frac{1}{26} \sum_{1991}^{2016} \bar{p}(L, t)^2}} \quad (15)$$

Bias share:

$$V(h) = \frac{\left[\frac{1}{26} \sum_{1991}^{2016} q(L, Q(h), t)^2 - \frac{1}{26} \sum_{1991}^{2016} \bar{p}(L, t)^2 \right]^2}{\frac{1}{26} \sum_{1991}^{2016} e(L, Q(h), t)^2} \quad (16)$$

The spread share:

$$S(h) = \frac{[S_q(h) - S_{\bar{q}}(h)]^2}{\frac{1}{26} \sum_{1991}^{2016} e(L, Q(h), t)^2} \quad (17)$$

where $S_q(h)$ and $S_{\bar{q}}(h)$ are the standard deviations of the respective quarter.

The covariance share:

$$K(h) = \frac{2(1 - r_{q, \bar{p}}(h)) S_q(h) - S(h)}{\frac{1}{26} \sum_{1991}^{2016} e(L, Q(h), t)^2} \quad (18)$$

where $r_{q, \bar{p}}(h)$ is the correlation coefficient between q and p . Thus $V(h) + S(h) + K(h) = 1$.

Table 10. MAE of WES Survey Quantitative Inflation Question

	4-step forecast (QI)	3-step forecast (QII)	2-step forecast (QIII)	1-step forecast (QIV)
Brazil	67.52	99.05	94.00	122.19
Canada	0.51	0.43	0.34	0.41
Switzerland	0.59	0.41	0.32	0.30
Chile	0.97	1.04	0.89	0.93
Colombia	1.33	1.14	0.92	0.65
Czech Republic	2.25	1.66	2.14	1.39
United Kingdom	0.76	0.72	0.68	0.77
Korea	1.26	1.11	0.91	0.78
Mexico	1.63	1.22	2.14	1.79
Norway	0.61	0.51	0.43	0.31
Hungary	1.53	0.98	0.82	0.98
Philippines	1.82	1.45	0.97	1.03
Poland	2.79	1.44	3.52	3.13
Sweden	0.82	0.67	0.71	0.75
Thailand	1.34	1.15	1.16	0.81
South Africa	1.32	1.10	1.02	0.84

Table 11. U-Statistic of WES Survey Quantitative Inflation Question

	4-step forecast (QI)	3-step forecast (QII)	2-step forecast (QIII)	1-step forecast (QIV)
Brazil	0.001	0.001	0.001	0.001
Canada	0.138	0.113	0.083	0.115
Switzerland	0.237	0.162	0.126	0.120
Chile	0.022	0.028	0.027	0.033
Colombia	0.010	0.009	0.007	0.005
Czech Republic	0.075	0.074	0.087	0.057
United Kingdom	0.110	0.111	0.112	0.122
Korea	0.075	0.067	0.055	0.054
Mexico	0.022	0.011	0.022	0.019
Norway	0.143	0.118	0.101	0.079
Hungary	0.011	0.007	0.006	0.008
Philippines	0.046	0.039	0.027	0.025
Poland	0.010	0.004	0.032	0.033
Sweden	0.141	0.121	0.151	0.210
Thailand	0.118	0.091	0.081	0.058
South Africa	0.030	0.026	0.024	0.021

Figure 17. Countries' Quantitative Inflation Expectations and Annual Inflation

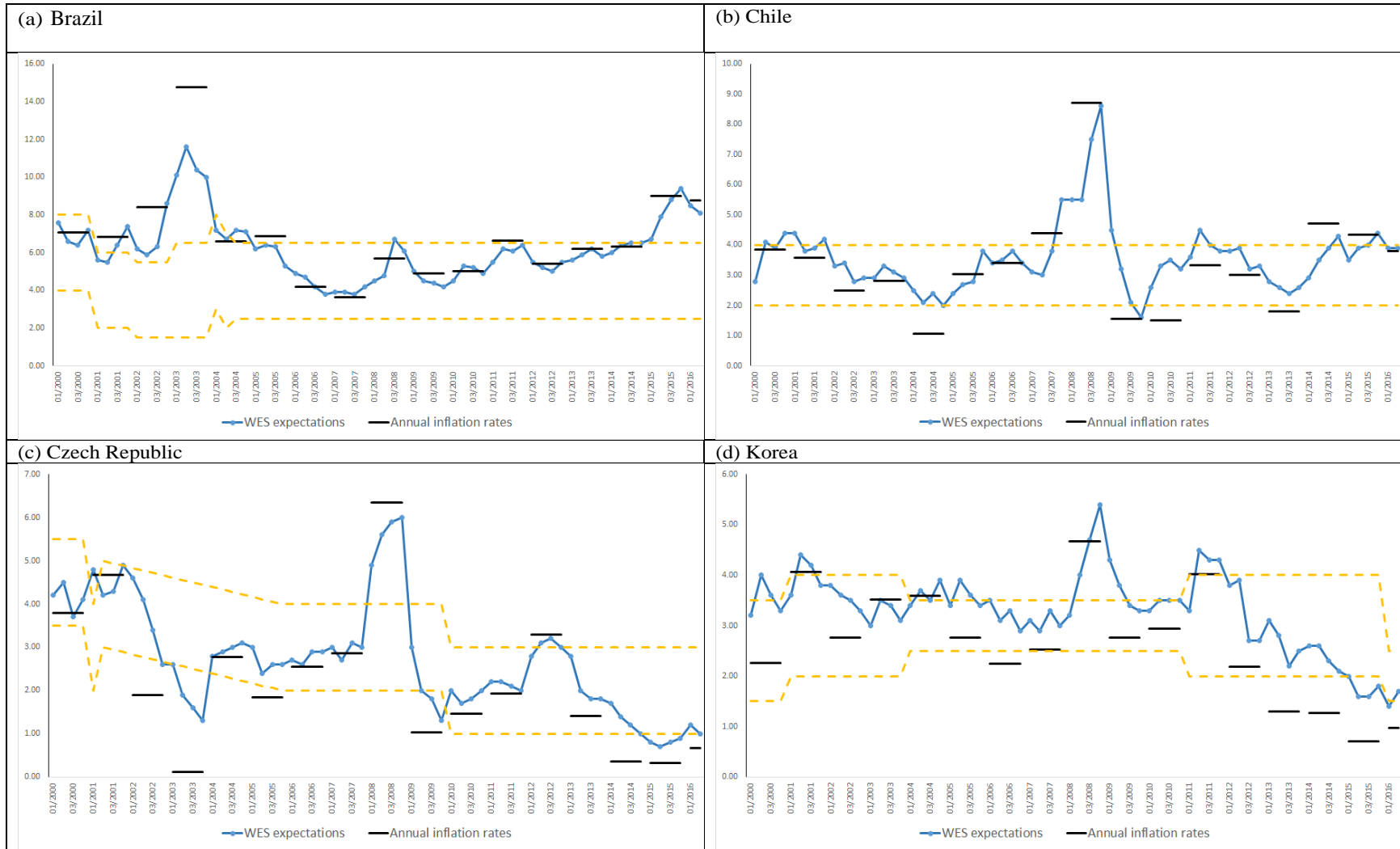

(e) Mexico

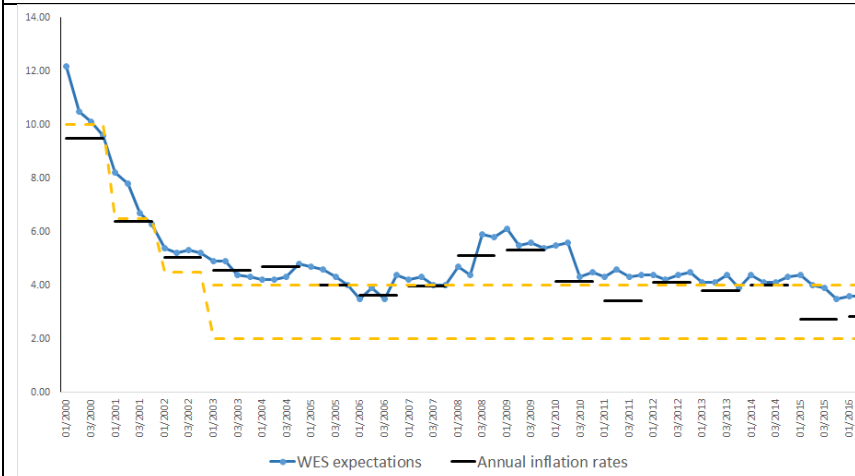

(f) Philippines

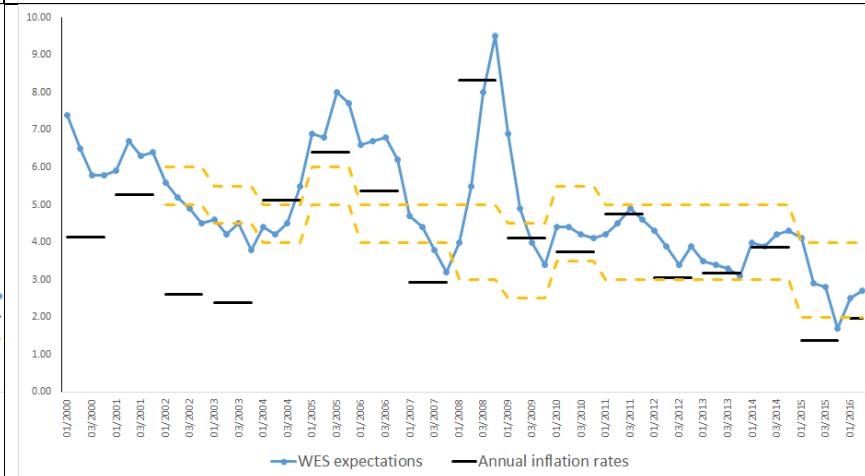

(g) Poland

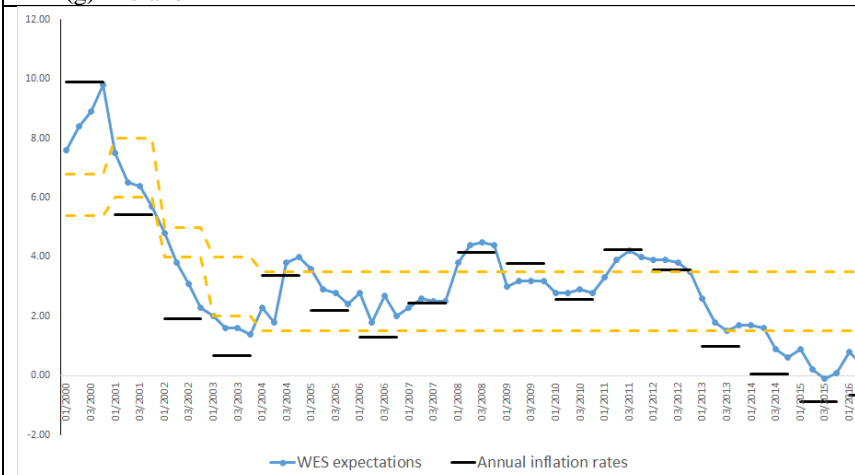

(h) South Africa

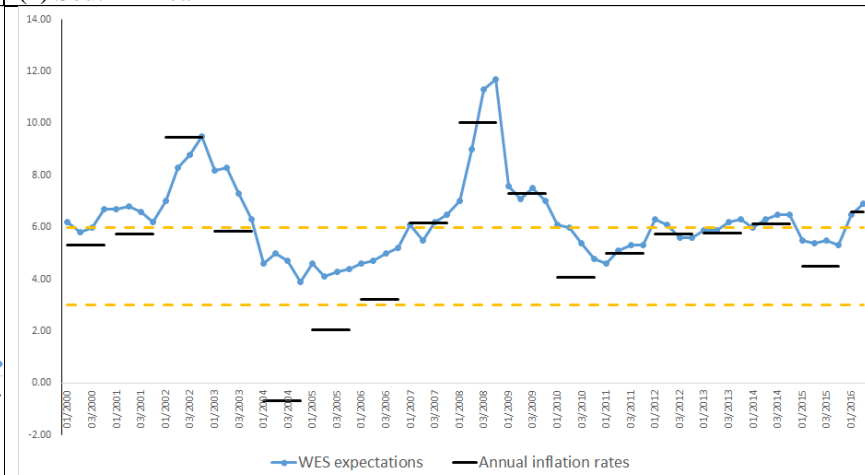

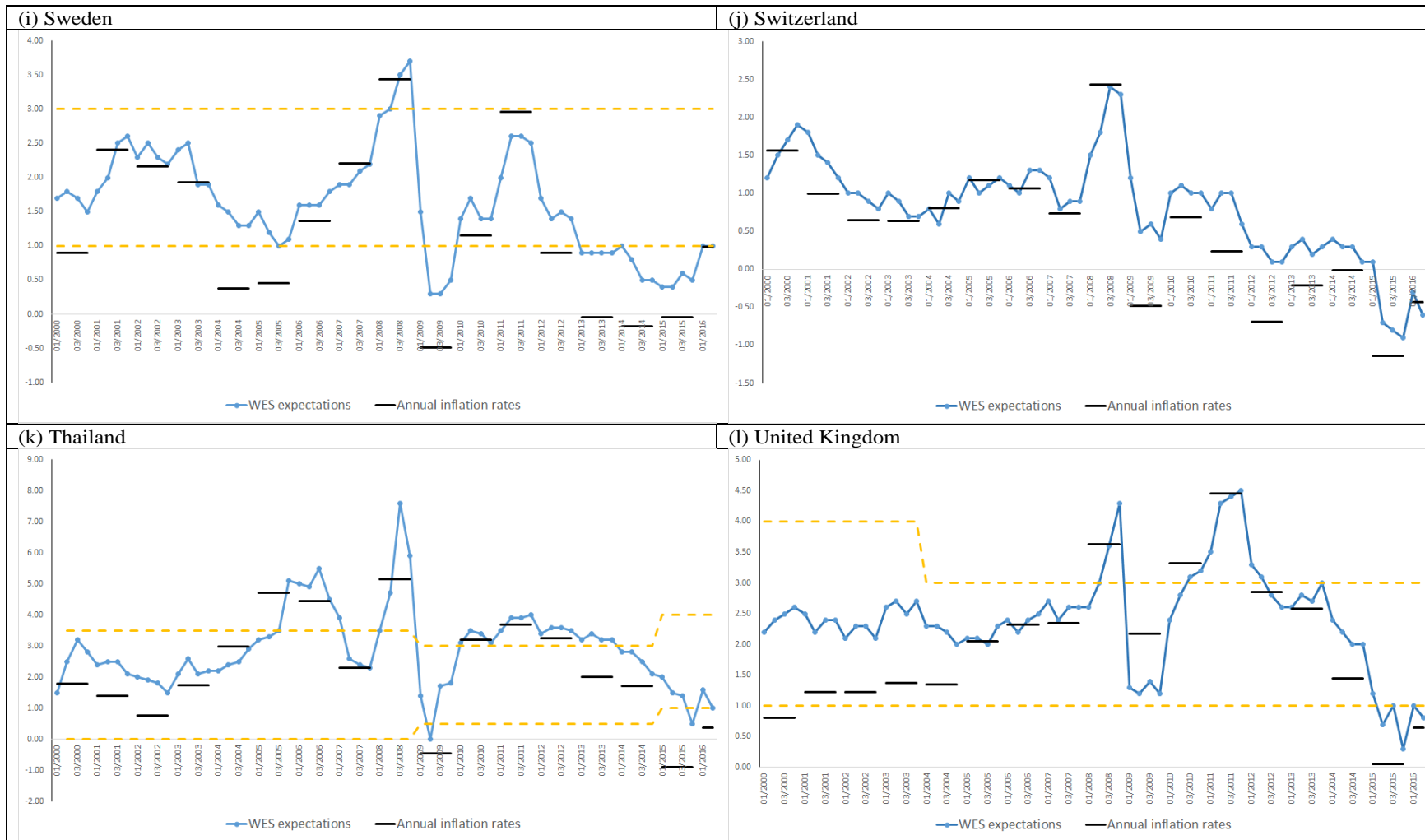

Source: WES survey, OECD statistics, and IMF data.

Figure 18. Quarter-Specific Forecasting Error by Country

Quarter-specific forecasting errors Brazil

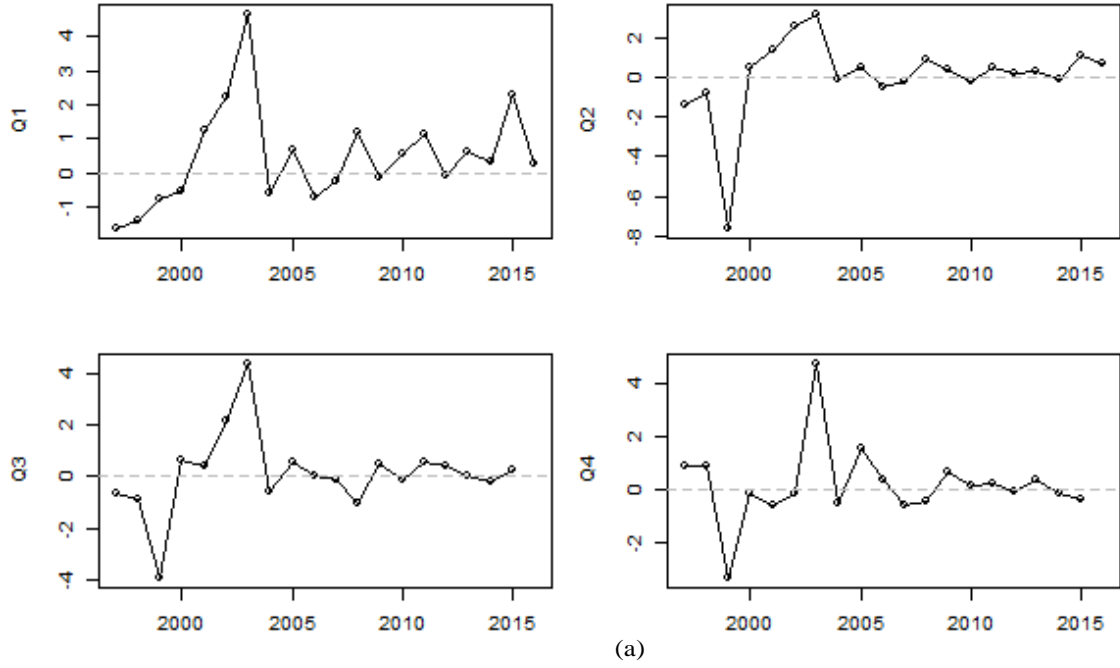

Quarter-specific forecasting errors Canada

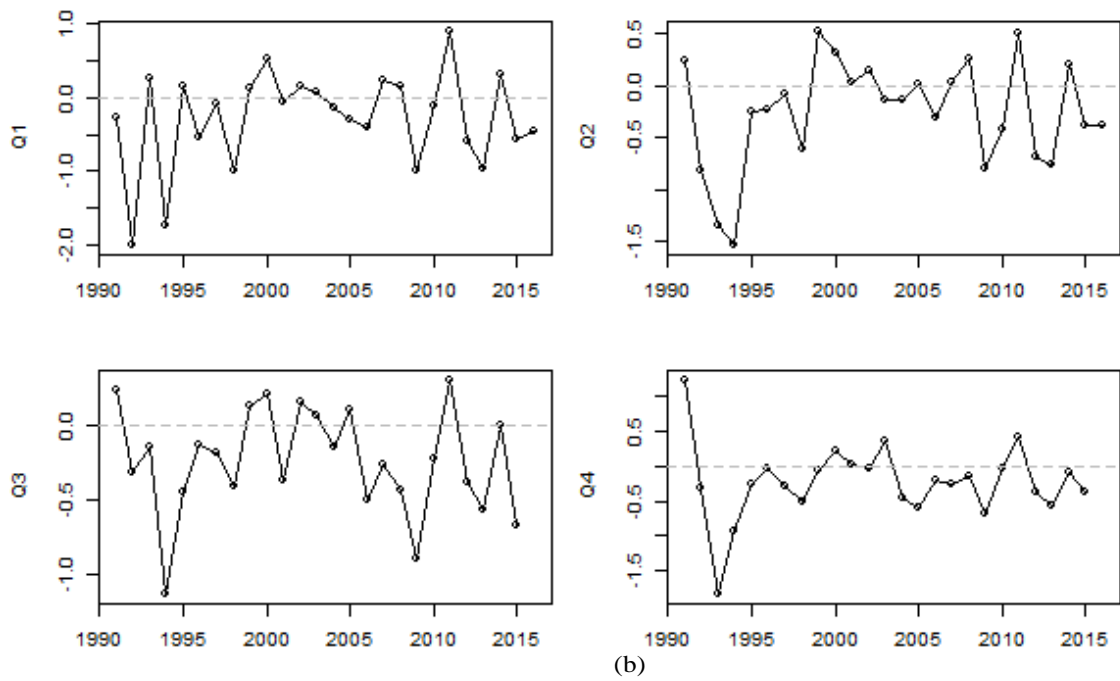

Quarter-specific forecasting errors Chile

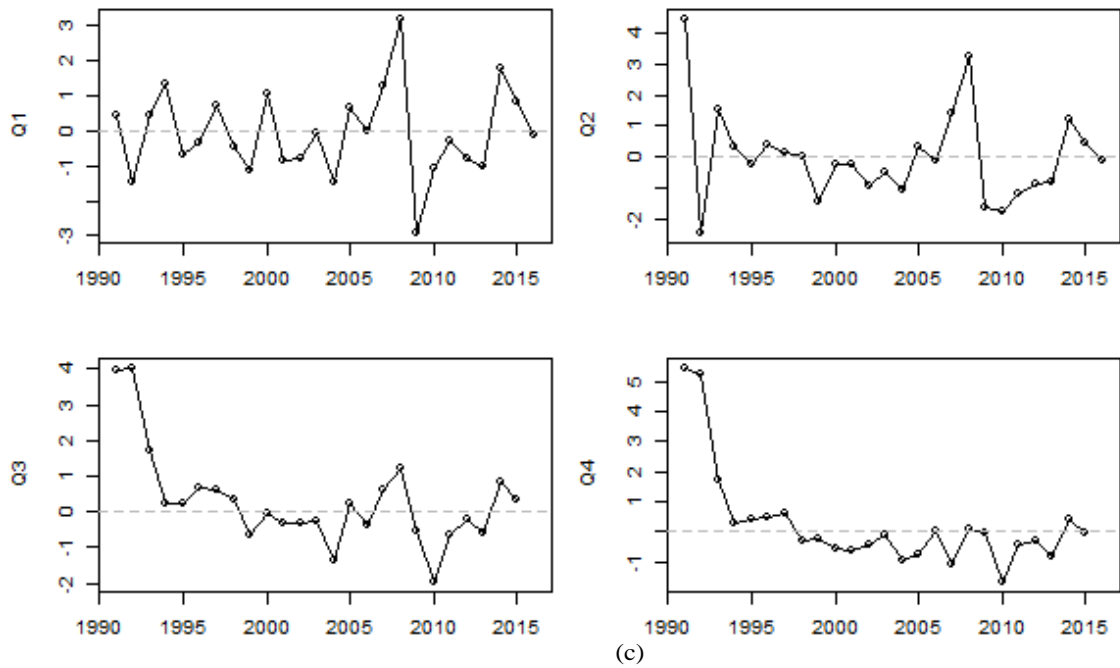

Quarter-specific forecasting errors Colombia

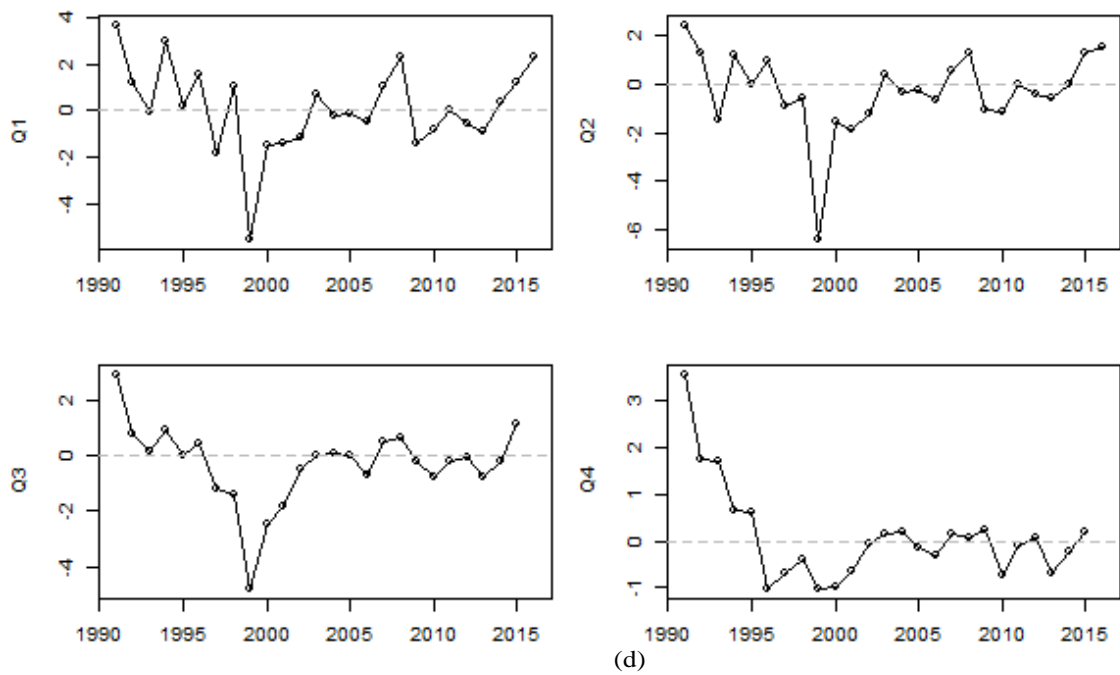

Quarter-specific forecasting errors Czech Republic

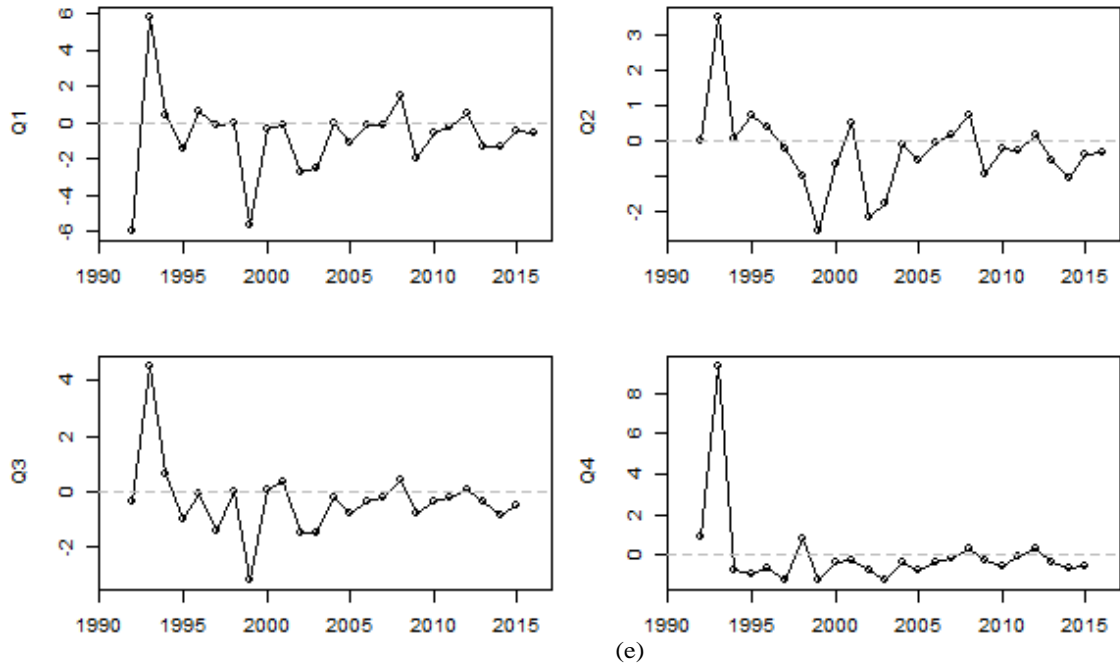

Quarter-specific forecasting errors Hungary

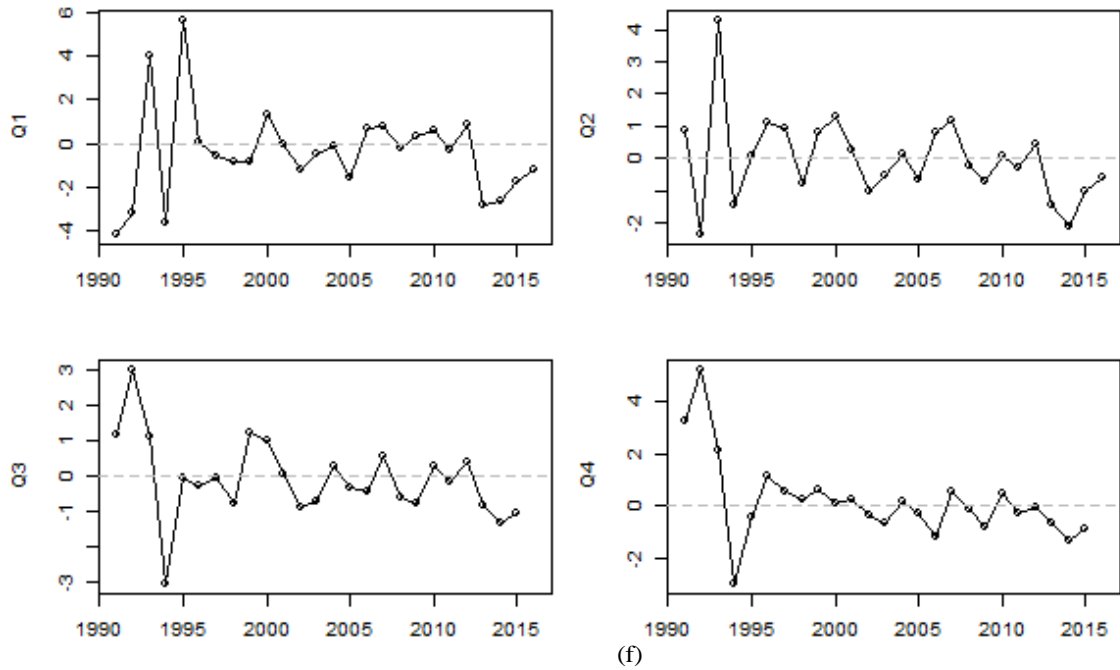

Quarter-specific forecasting errors Korea

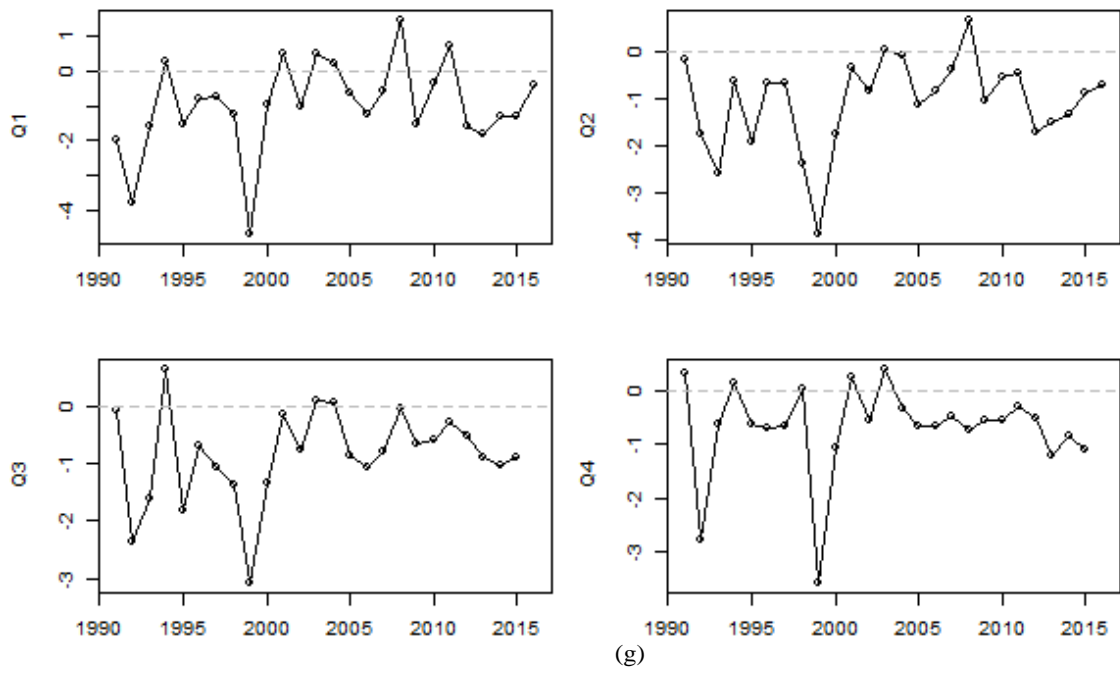

Quarter-specific forecasting errors Mexico

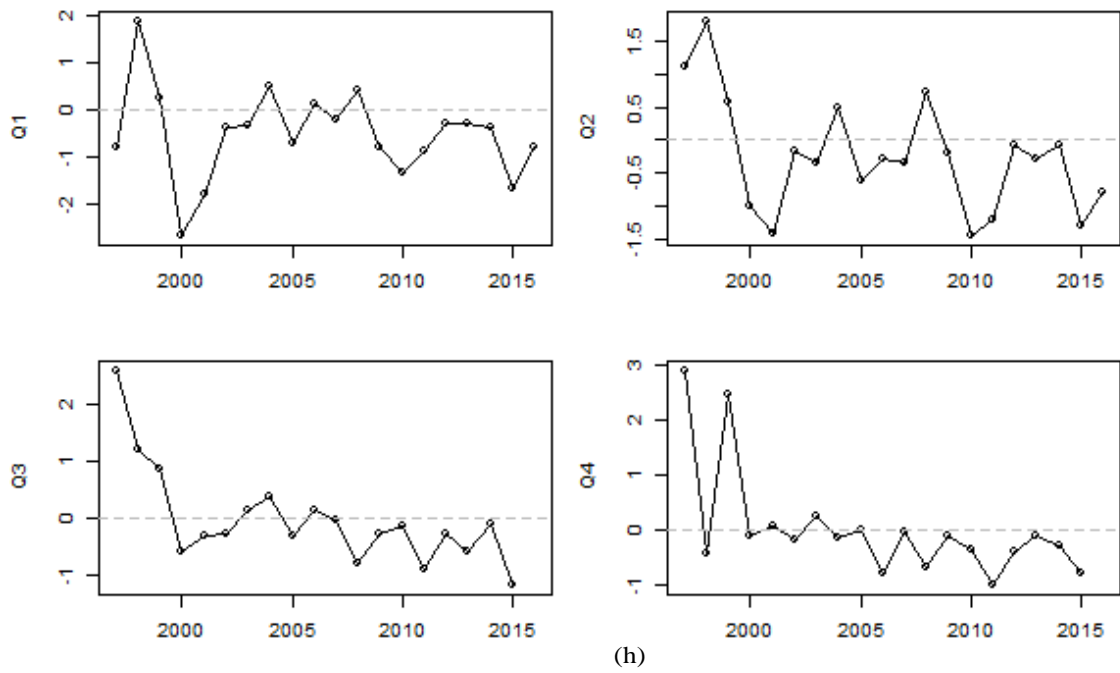

Quarter-specific forecasting errors Norway

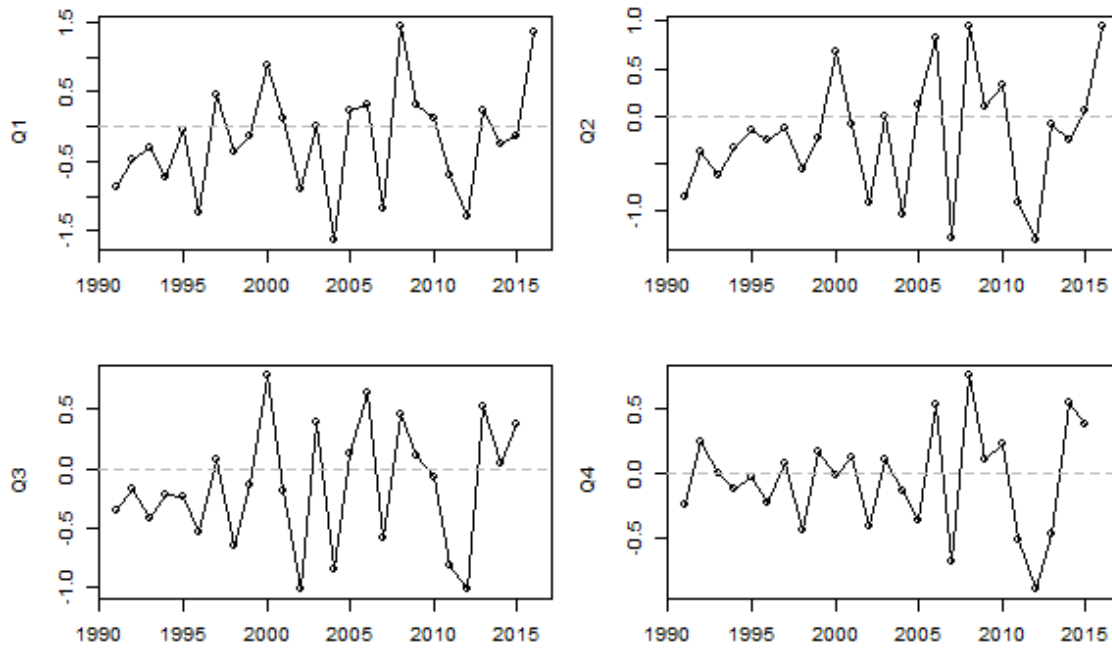

Quarter-specific forecasting errors Philippines

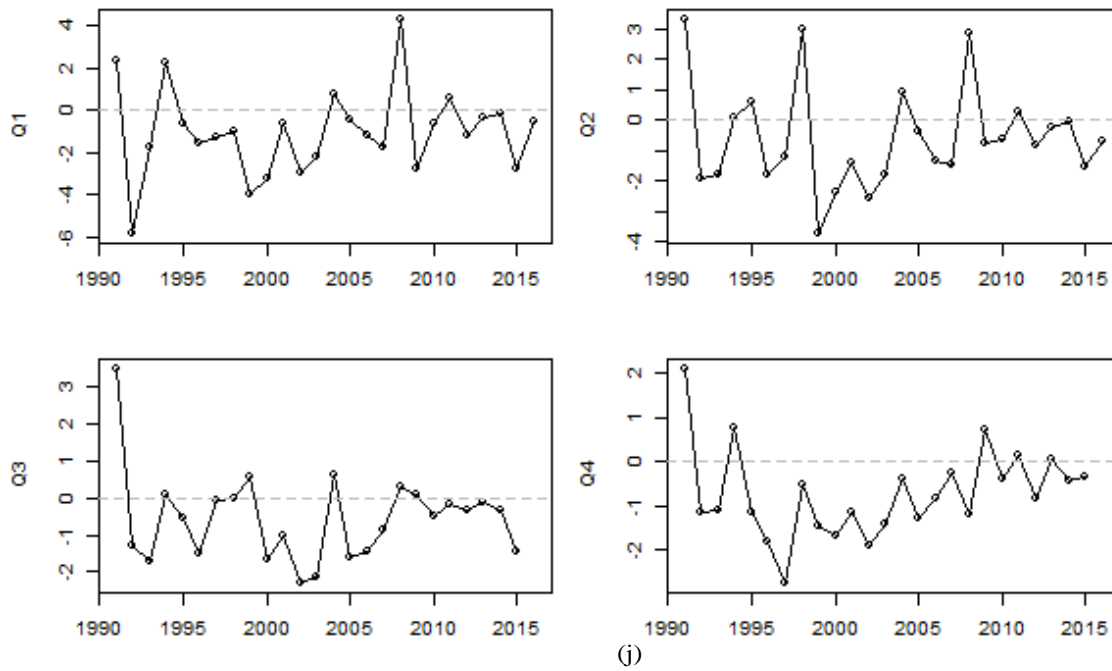

Quarter-specific forecasting errors Poland

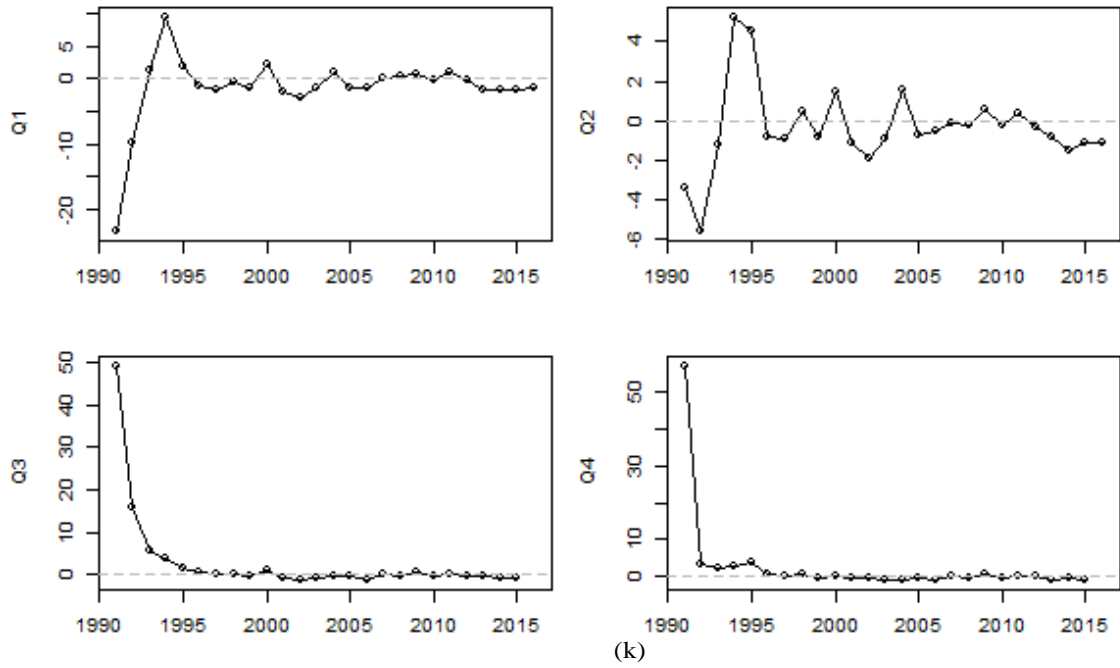

Quarter-specific forecasting errors South AF

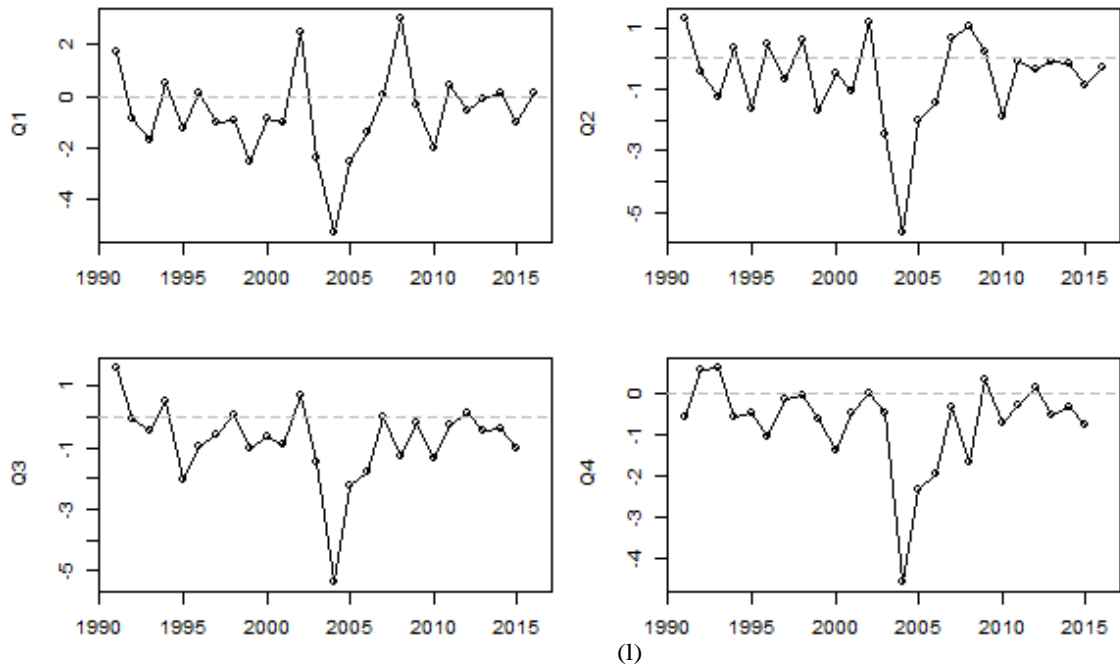

Quarter-specific forecasting errors Sweden

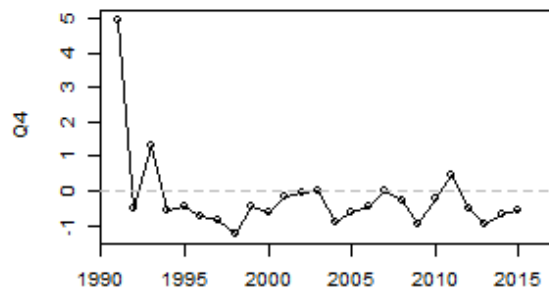
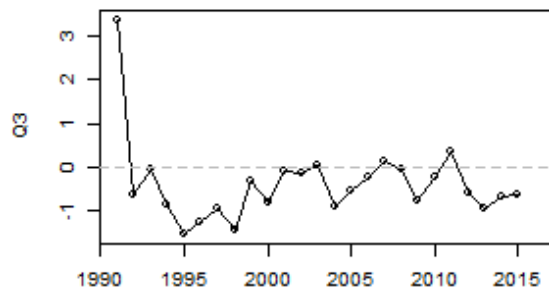
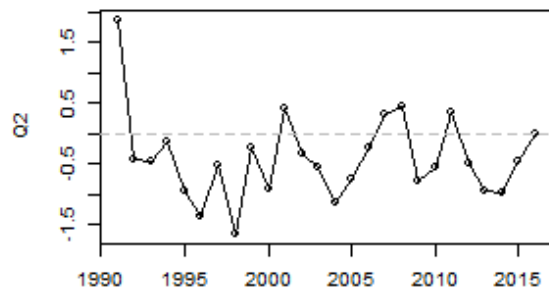

(m)

Quarter-specific forecasting errors Switzerland

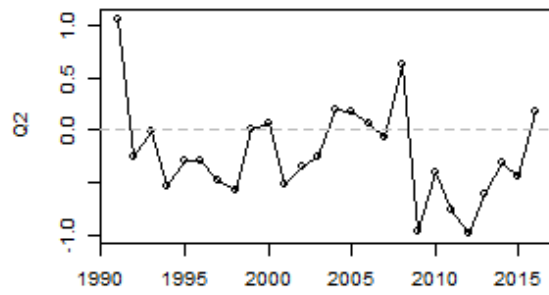
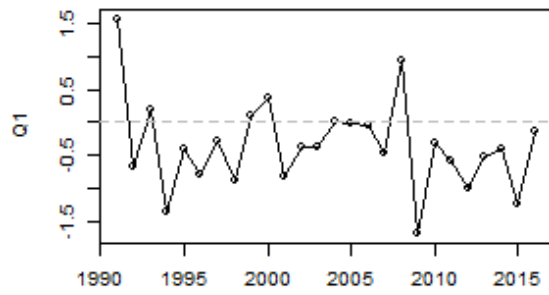

(n)

Quarter-specific forecasting errors Thailand

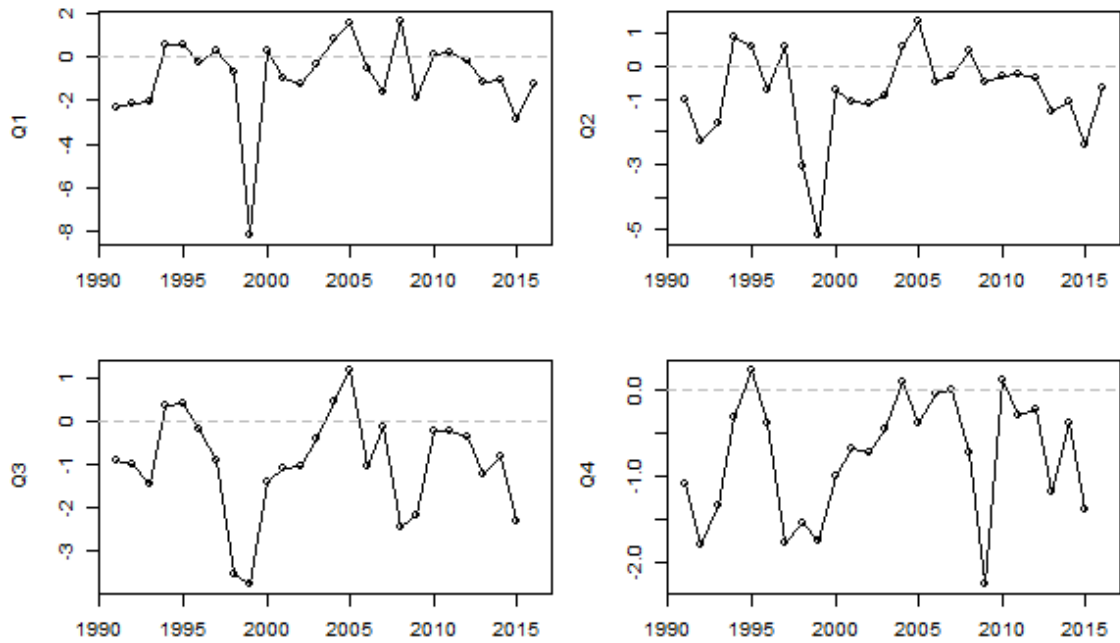

(o)

Quarter-specific forecasting errors United Kingdom

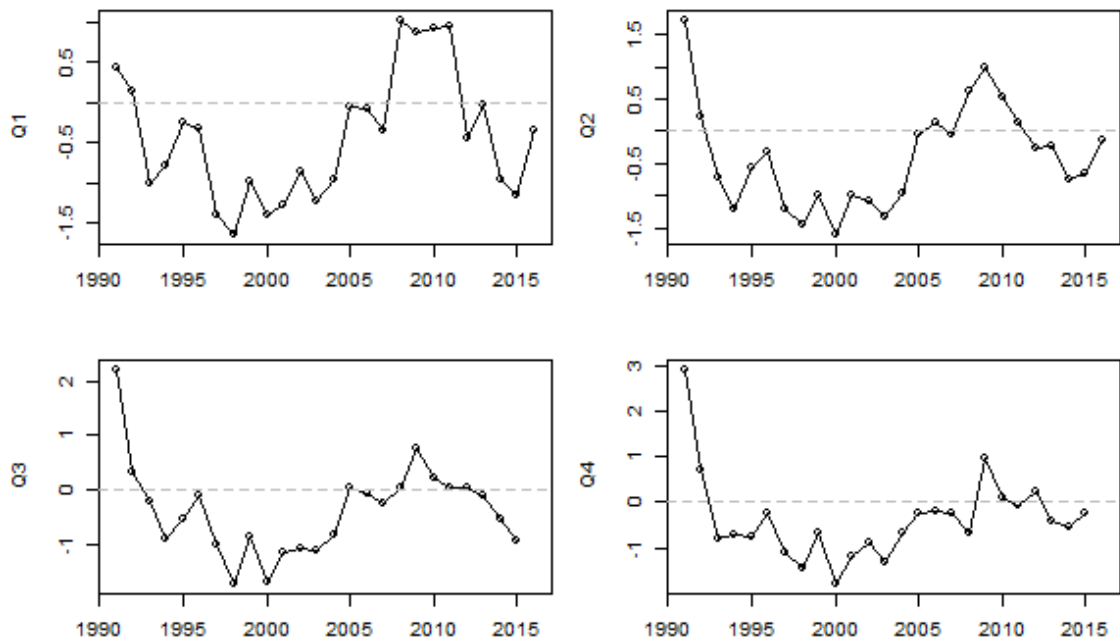

(p)

Appendix B. Self-Organizing Map Validation

B.1 Choice of Topology

In this section, we present the best topology according to available data. This includes presenting the dimensions of the map and the form of the neighborhood. In order to have more neighbors around the winning neuron, we choose the hexagonal topology that allocates six neurons around the center one. For the dimensions we found several empirical rules. The first rule is to have the number of neurons increase with the square root of the number of data points. This gives us a map of 40 neurons. The second rule is to have 10 samples per neuron, which gives a total of 192 neurons.

We tried different architectures to try to get enough granularity on the map with small topographic error. Unfortunately, there is not a set criterion by which to judge performance in SOM networks. Therefore, to complete our goal of finding the agent's clusters before the oil price shock, we divide our data into two sets, before and after the shock. Thus, the training data will be from the third quarter of 1991 to the second quarter of 2014.

Using the R software, we analyzed various architectures: the dimensions of the map (3x10 vs. 18x10), the storage of their topographic errors, and their granularity.¹⁹ Figure 19 shows us the choice of hexagonal topology of 10x10.

Figure 19. Best Matching Unit Error, Error Node Distance, Quantization Error and Sample per Neuron vs. Map Width Node Size

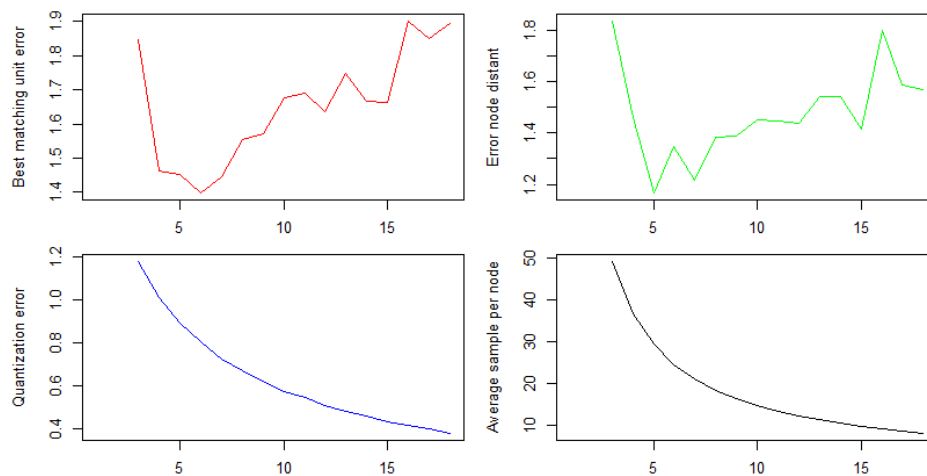

¹⁹ The quantization error is not comparable between maps because it is susceptible to map size. To see more about topographic errors, see the Post-training analysis section.

B.2 Post-Training Analysis

Following Wehrens (2007) and Lynn (2014) we analyze the results from the trained map to validate the previous results. The training progress shows the mean distance between neuron's weights to the samples represented through each iteration. When the training progress reaches a minimum, no more iterations are required. See Figure 21.

Figure 21.

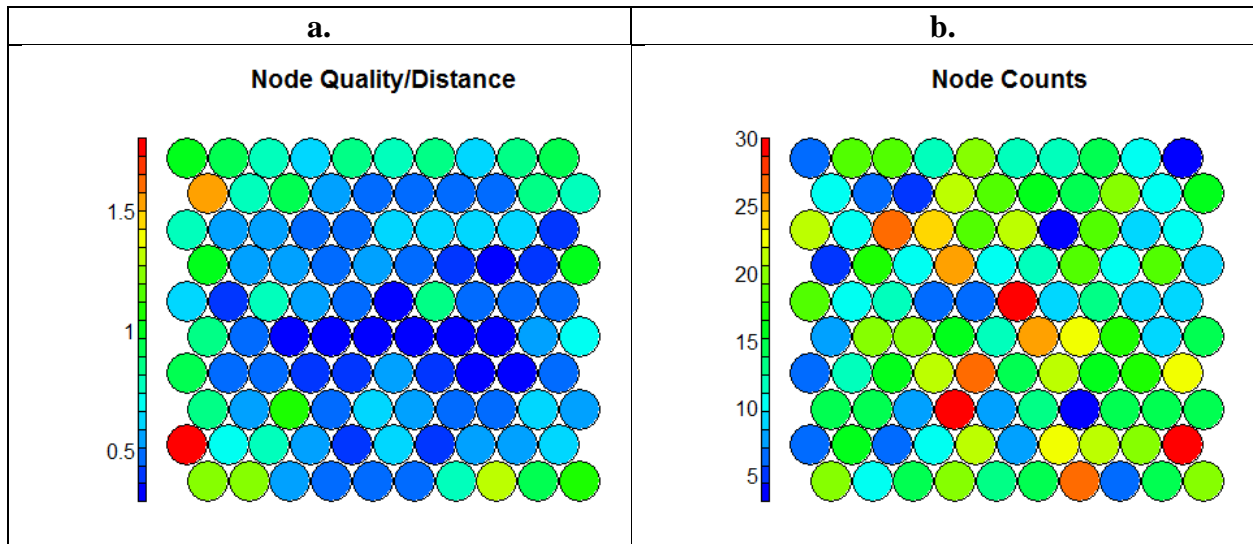

In Figure 21(a), the node or quality distance map is shown. This map displays an approximation of the distance per node to the sample that they are representing; this is known as the quantization error. According to the quantization error, the smaller the distance, the better the map. When it is large, some input vectors are not adequately represented on the map. However, the error is also subject to map sizes: if the map is large, it could be close to zero. This would represent overfitting because the number of neurons on the map should be significantly smaller than the sample size. The mean quantization error found is 0.5888693.

In Figure 21(b), one can analyze how many samples are mapped to each node on the map. Ideally, we want the sample distributions to be relatively uniform. Our map is relatively uniform, including between 10 to 15 samples per neuron, and there are non-empty neurons.

Figure 22.

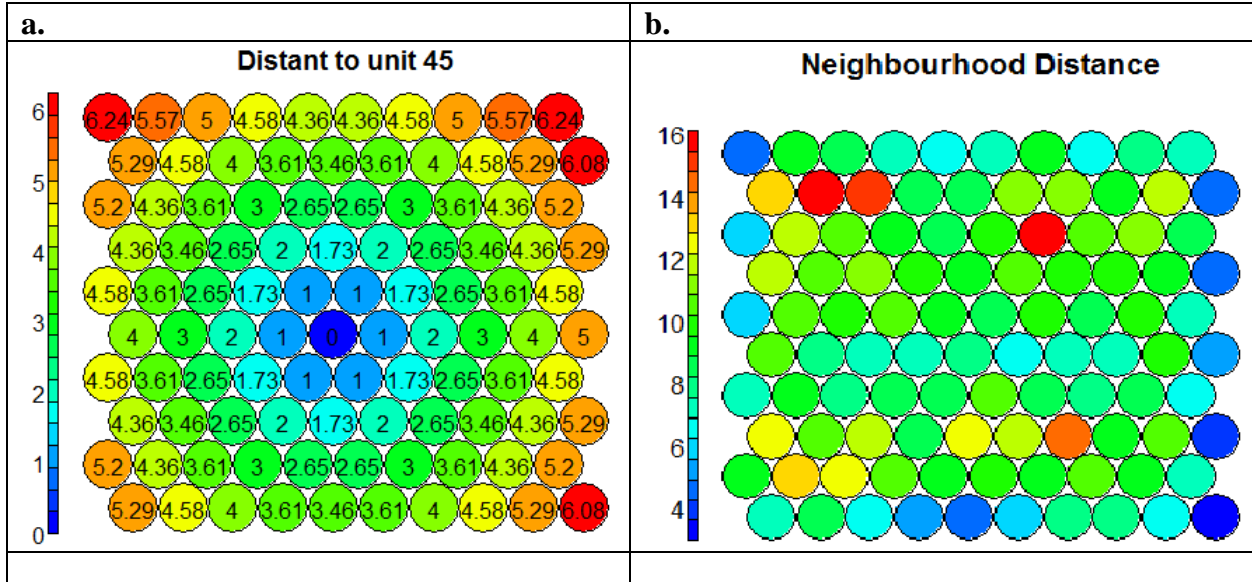
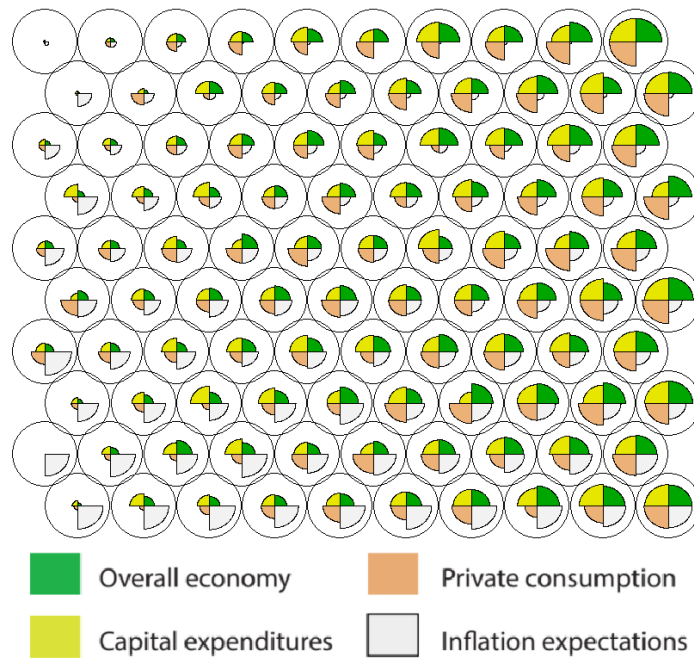

Figure 22(b) shows a map that is also named the U-matrix and which shows the distance between each neuron and its immediate neighbors. Because we choose a hexagonal neighbor, each neuron has six neurons in its neighborhood. This map also assists in identifying similar neurons.

Figure 23. Weight Vectors



The weight vectors plot, Figure 23, shows the weights associated with each neuron. Each weight vector is similar to the variable that it represents due to Kohonen’s learning rule. The weight distributions on the map represent: green for the overall economy, yellow for capital expenditures, orange for private consumption, and white for inflation expectations. This allows us to distinguish patterns of the variables.

Finally, we present three measures of topographic errors. We already looked at the first one, the quantization error, which is the average distance between each variable and the closest neuron. To reiterate our quantization error is 0.5888693. The best-matching error is the average distance between the best matching unit and the following, which is 1.568656. This error is in terms of coordinates in the map. Similarly, the node distance error is the average distance between all pairs of most similar codebook vectors, which is 1.387984.

B.3 Non-Linear Auto-Regressive Neural Networks Validation and Other Results

B.3.1 Lag Selection

Table 12. Lag Statistics on All Data, One Step-Ahead Forecasts, Sample of 30

Countries	Lags	1	2	3	4	5	6	7	8	9	10
Brazil	mean	2.01	1.99	1.88	1.90	1.93	1.86	1.87	1.88	1.89	1.88
	median	1.99	1.99	1.88	1.90	1.90	1.86	1.87	1.88	1.89	1.88
Canada	mean	1.17	1.38	1.30	1.29	1.30	1.30	1.31	1.32	1.29	1.30
	median	1.16	1.38	1.31	1.29	1.30	1.30	1.31	1.32	1.29	1.30
Switzerland	mean	1.03	1.08	1.04	1.04	1.03	1.03	0.83	0.33	0.50	0.65
	median	1.03	1.09	1.04	1.04	1.03	1.03	0.87	0.31	0.50	0.83
Chile	mean	2.22	2.09	2.08	2.19	2.10	2.04	2.07	2.10	2.04	2.09
	median	2.22	2.09	2.05	2.23	2.17	1.95	2.19	2.15	2.04	2.10
Colombia	mean	1.56	1.58	1.58	1.60	1.59	1.61	1.57	1.61	1.57	1.60
	median	1.56	1.58	1.58	1.59	1.57	1.59	1.55	1.58	1.54	1.57
Czech R.	mean	1.86	2.05	1.99	1.94	1.85	0.89	1.73	1.78	0.39	0.37
	median	1.87	2.05	1.99	1.94	1.85	0.89	1.73	1.78	0.32	0.29
United K.	mean	1.28	1.40	1.39	1.38	1.26	1.21	1.09	0.99	1.15	0.94
	median	1.27	1.41	1.39	1.38	1.26	1.21	1.10	1.00	1.16	0.85
Korea R.	mean	1.36	1.47	1.45	1.46	1.45	1.35	1.36	1.30	1.31	1.32

	median	1.36	1.47	1.45	1.46	1.45	1.35	1.36	1.30	1.29	1.31
Mexico	mean	1.27	1.37	1.33	1.14	1.12	0.91	1.24	1.31	1.02	0.28
	median	1.24	1.37	1.32	1.14	1.12	0.90	1.44	1.35	1.18	0.25
Norway	mean	1.86	2.08	1.97	1.98	1.92	1.91	1.83	1.81	1.76	1.75
	median	1.86	2.08	1.97	1.98	1.92	1.91	1.83	1.81	1.76	1.75
Hungary	mean	1.64	1.86	1.78	1.68	1.72	1.63	1.52	1.51	1.64	1.60
	median	1.64	1.86	1.78	1.68	1.73	1.63	1.52	1.51	1.64	1.59
Philippines	mean	2.66	2.50	2.39	2.41	2.43	2.45	2.26	2.17	1.51	1.71
	median	2.65	2.50	2.39	2.41	2.43	2.45	2.26	2.23	1.94	1.70
Poland	mean	1.74	1.82	1.25	0.95	1.35	1.30	0.89	0.87	0.32	0.63
	median	1.73	1.84	1.26	0.95	1.35	1.30	0.89	0.87	0.27	0.63
Sweden	mean	1.25	1.16	1.11	1.13	1.11	1.12	1.07	1.07	1.09	1.06
	median	1.24	1.16	1.11	1.13	1.11	1.12	1.07	1.07	1.09	1.06
Thailand	mean	1.67	1.87	1.46	1.68	1.35	1.35	1.27	1.29	1.32	1.35
	median	1.67	1.87	1.46	1.63	1.35	1.35	1.27	1.29	1.32	1.36
South A.	mean	2.25	2.41	2.25	2.25	2.18	2.19	2.19	2.16	1.74	1.92
	median	2.25	2.41	2.25	2.25	2.18	2.19	2.21	2.16	1.69	1.85

Table 13. Lag Statistics on Train Data, One Step-Ahead Forecast, Sample of 30

Countries	Lags	1	2	3	4	5	6	7	8	9	10
Brazil	mean	2.04	1.98	1.88	1.90	1.94	1.86	1.87	1.89	1.89	1.86
	median	2.03	1.98	1.88	1.90	1.90	1.86	1.87	1.89	1.89	1.86
Canada	mean	1.10	1.34	1.28	1.26	1.27	1.27	1.28	1.30	1.24	1.26
	median	1.07	1.34	1.28	1.26	1.27	1.27	1.28	1.30	1.24	1.26
Switzerland	mean	1.01	1.07	1.05	1.04	1.03	1.03	0.80	0.29	0.46	0.64
	median	1.01	1.07	1.05	1.04	1.03	1.03	0.85	0.27	0.46	0.83
Chile	mean	2.04	2.03	2.02	2.15	2.04	1.96	1.99	2.00	1.94	2.01
	median	2.03	2.03	1.98	2.18	2.11	1.87	2.11	2.07	1.94	2.02
Colombia	mean	1.27	1.46	1.46	1.48	1.48	1.49	1.45	1.45	1.41	1.44
	median	1.26	1.46	1.46	1.48	1.46	1.47	1.43	1.43	1.38	1.41
Czech R.	mean	1.96	2.17	2.11	2.05	1.94	0.91	1.78	1.83	0.22	0.26
	median	1.97	2.17	2.10	2.05	1.94	0.91	1.78	1.83	0.15	0.19
United K.	mean	1.31	1.45	1.43	1.42	1.29	1.25	1.12	0.98	1.18	0.95
	median	1.31	1.46	1.43	1.42	1.29	1.25	1.13	1.01	1.18	0.85
Korea R.	mean	1.28	1.44	1.40	1.41	1.39	1.27	1.26	1.23	1.23	1.24
	median	1.28	1.44	1.40	1.41	1.39	1.27	1.26	1.23	1.22	1.23
Mexico	mean	1.34	1.45	1.40	1.20	1.18	0.97	1.31	1.40	1.07	0.20
	median	1.32	1.45	1.39	1.20	1.18	0.95	1.53	1.44	1.27	0.22

Countries	Lags	1	2	3	4	5	6	7	8	9	10
Norway	mean	1.91	2.14	2.00	2.01	1.95	1.90	1.81	1.79	1.75	1.75
	median	1.90	2.14	2.00	2.01	1.95	1.90	1.81	1.79	1.75	1.75
Hungary	mean	1.48	1.76	1.67	1.52	1.53	1.45	1.31	1.33	1.52	1.48
	median	1.48	1.77	1.67	1.52	1.55	1.45	1.31	1.33	1.52	1.48
Philippines	mean	2.59	2.37	2.26	2.29	2.31	2.32	2.15	2.03	1.26	1.52
	median	2.58	2.37	2.26	2.29	2.31	2.32	2.15	2.10	1.74	1.53
Poland	mean	1.79	1.90	1.27	0.94	1.34	1.32	0.90	0.87	0.01	0.00
	median	1.78	1.91	1.29	0.94	1.34	1.32	0.90	0.87	0.01	0.00
Sweden	mean	1.27	1.12	1.08	1.09	1.05	1.06	1.00	1.01	1.03	1.00
	median	1.26	1.13	1.08	1.09	1.05	1.06	1.00	1.01	1.03	1.00
Thailand	mean	1.67	1.95	1.50	1.75	1.39	1.38	1.29	1.31	1.35	1.38
	median	1.67	1.95	1.50	1.69	1.39	1.38	1.29	1.31	1.35	1.40
South A.	mean	2.22	2.33	2.13	2.13	2.02	2.03	1.99	1.94	1.46	1.66
	median	2.21	2.33	2.13	2.13	2.02	2.03	2.03	1.94	1.41	1.54

B.3.2 Post-Training Analysis

Table 14. Neural Networks Results of Training Phase

Countries	Total number of	Effective number of parameters	Maximum sum squared of parameters	Sum squared of parameters	Total epoch
Brazil	31	2.88	2760	1.74	355
Canada	101	7.66	53	1.01	622
Chile	61	4.68	91.3	1.11	228
Colombia	71	5.02	72	0.72	1000
Czech Republic	81	31.17	61.6	20.96	314
Korea	41	2.99	280	1.10	1000
Mexico	81	20.71	61.7	9.91	114
Norway	31	2.96	2760	1.49	70
Switzerland	101	38.81	53.4	22.16	330
United Kingdom	81	10.20	64.7	3.39	245
Hungary	121	14.04	46	2.9722	889
Philippines	31	2.04	2760	1.30	108
Poland	91	19.48	58.2	7.43	156
Sweden	31	2.75	2760	1.53	484
Thailand	61	9.16	91.3	4.09	298
South A.	31	2.64	2760	1.54	502

Countries	Best epoch	Error Autocorrelation	Input-error Correlation	Correlation coefficient		
				Training R	Testing R	All R
Brazil	2	1	0	0.605	0.877	0.632
Canada	99	1	0	0.570	0.334	0.551
Chile	56	1	0	0.702	-0.049	0.678
Colombia	429	1	0	0.445	0.560	0.463
Czech Republic	253	1	0	0.885	0.607	0.884
Korea	1000	1	0	0.523	-0.464	0.554
Mexico	64	1	0	0.875	0.474	0.879
Norway	4	1	0	0.641	-0.041	0.640
Switzerland	240	1	0	0.935	0.759	0.921
United Kingdom	77	1	0	0.740	0.473	0.743
Hungary	103	1	0	0.820	-0.157	0.826
Philippines	12	0	0	0.678	0.077	0.652
Poland	129	1	0	0.887	0.605	0.895
Sweden	9	1	0	0.741	0.108	0.746
Thailand	151	1	0	0.674	0.181	0.664
South A.	8	0	0	0.744	0.545	0.739

B.3.3 MSE Evaluation

**Table 15. Neural Network Simulations Statistics by Datasets,
Sample of 1,000.**

	Brazil			Korea		
	All data	Training set	Testing set	All data	Training set	Testing set
mean	2.01	2.05	1.65	1.47	1.44	1.86
median	2.00	2.04	1.61	1.47	1.44	1.86
std	0.04	0.03	0.18	0.01	0.01	0.03
maximum	2.09	2.09	2.11	1.52	1.44	2.51
minimum	1.92	1.97	1.24	1.36	1.34	1.62

	Canada			Mexico		
	All data	Training set	Testing set	All data	Training set	Testing set
mean	1.33	1.31	1.52	0.97	1.03	0.34
median	1.32	1.30	1.52	0.90	0.95	0.30
std	0.06	0.06	0.01	0.24	0.24	0.17
maximum	2.09	2.09	2.11	3.91	4.00	2.94
minimum	1.92	1.97	1.24	0.90	0.95	0.30

	Chile			Norway		
	All data	Training set	Testing set	All data	Training set	Testing set
mean	2.21	2.17	2.69	1.87	1.91	1.41
median	2.23	2.18	2.68	1.86	1.90	1.42
std	0.06	0.07	0.03	0.04	0.04	0.03
maximum	1.33	1.36	1.01	2.06	2.12	1.51
minimum	0.55	0.54	0.67	1.82	1.86	1.25

	Colombia			Switzerland		
	All data	Training set	Testing set	All data	Training set	Testing set
mean	1.59	1.48	2.83	0.31	0.27	0.78
median	1.57	1.46	2.78	0.31	0.27	0.78
std	0.08	0.07	0.21	0.00	0.00	0.00
maximum	1.93	1.76	3.69	0.31	0.27	0.78
minimum	1.57	1.46	2.77	0.31	0.27	0.78

	Czech Republic			United Kingdom		
	All data	Training set	Testing set	All data	Training set	Testing set
mean	0.90	0.92	0.69	1.21	1.25	0.82
median	0.89	0.91	0.67	1.21	1.25	0.82
std	0.08	0.08	0.08	0.00	0.00	0.00
maximum	1.21	1.25	0.82	1.21	1.25	0.82
minimum	1.21	1.25	0.82	1.21	1.25	0.82

	Hungary			Philippines		
	All data	Training set	Testing set	All data	Training set	Testing set
mean	1.59	1.47	2.85	2.66	2.60	3.42
median	1.59	1.48	2.75	2.66	2.59	3.43
std	0.11	0.17	0.54	0.04	0.05	0.07
maximum	1.73	1.58	7.60	2.81	2.74	3.88
minimum	0.68	0.00	2.74	2.59	2.51	2.98

	Poland			Sweden		
	All data	Training set	Testing set	All data	Training set	Testing set
mean	0.89	0.90	0.72	1.25	1.26	1.14
median	0.89	0.90	0.72	1.24	1.25	1.15
std	0.01	0.01	0.01	0.03	0.04	0.09
maximum	1.02	1.04	0.80	1.35	1.37	1.31
minimum	0.88	0.90	0.66	1.21	1.21	0.86

	Thailand			South Africa		
	All data	Training set	Testing set	All data	Training set	Testing set
mean	1.69	1.76	0.90	2.27	2.23	2.64
median	1.63	1.69	0.91	2.25	2.22	2.63
std	0.09	0.10	0.02	0.07	0.07	0.10
maximum	1.82	1.91	0.91	2.64	2.58	3.35
minimum	1.63	1.69	0.86	2.22	2.18	2.43

B.3.4 Results, Other Countries

Figure 24. Countries' Inflation Rate Forecast for the Next Six Months by NAR-NN

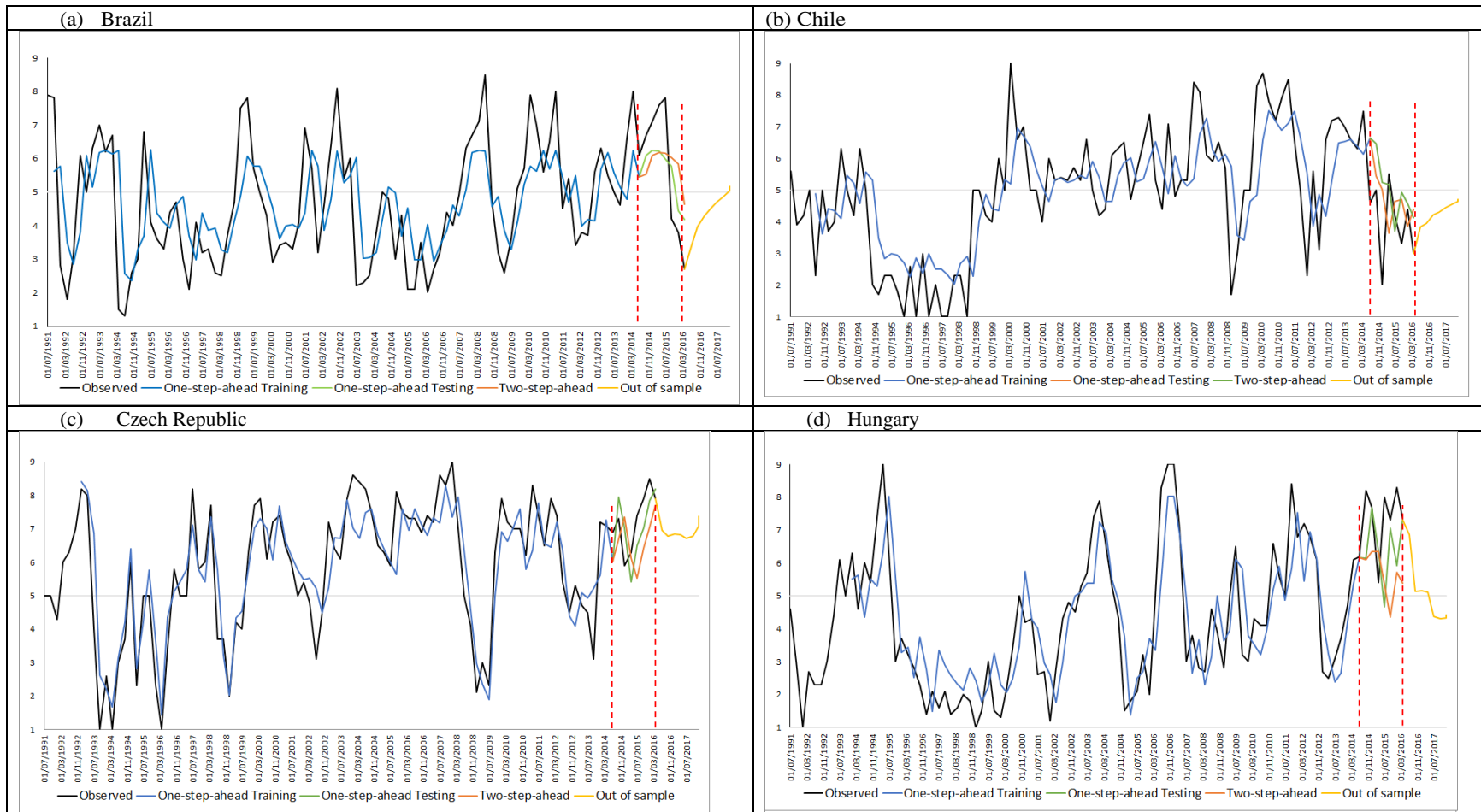

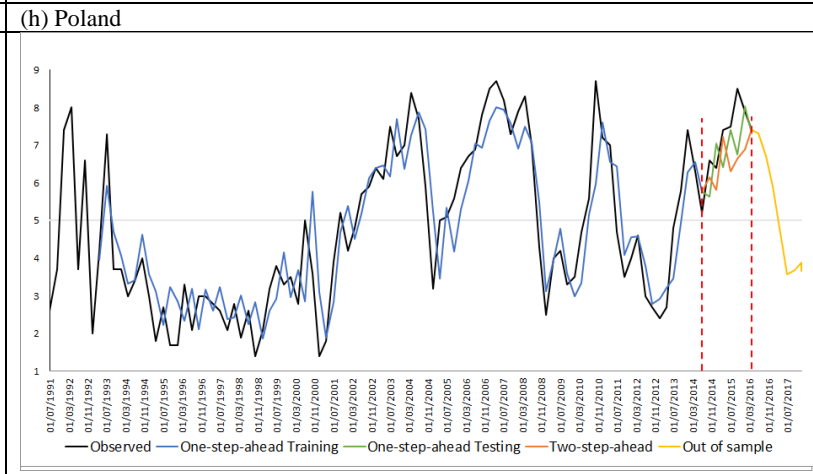
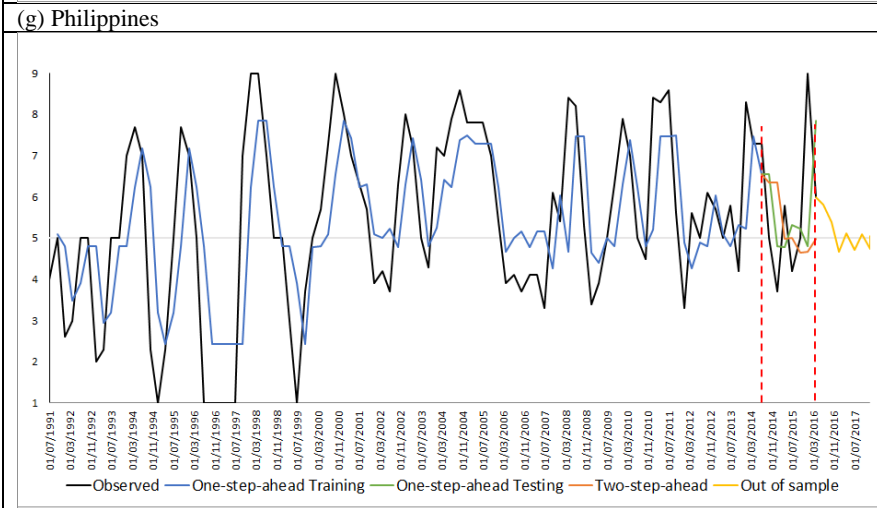
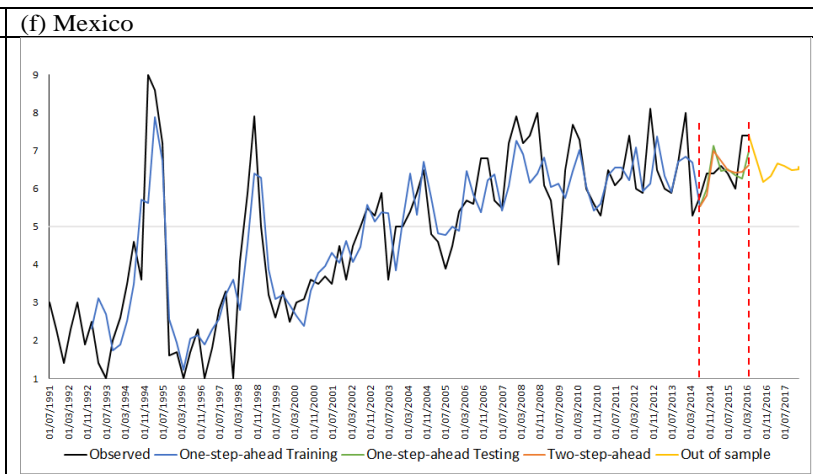
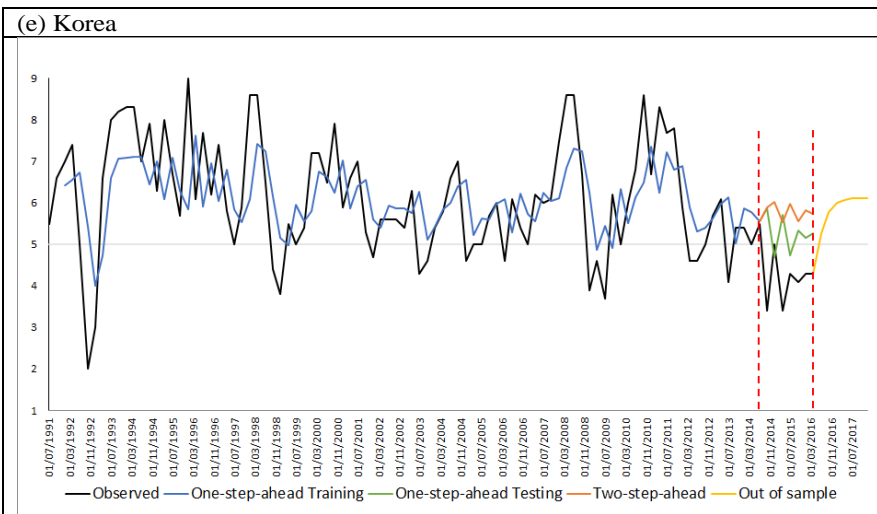

(i) South Africa

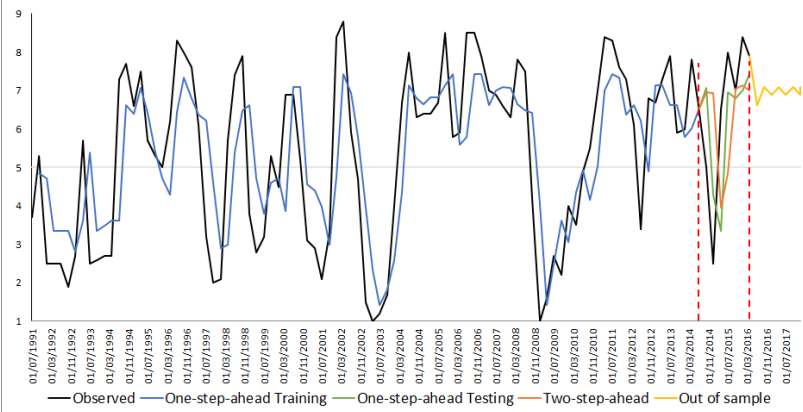

(j) Sweden

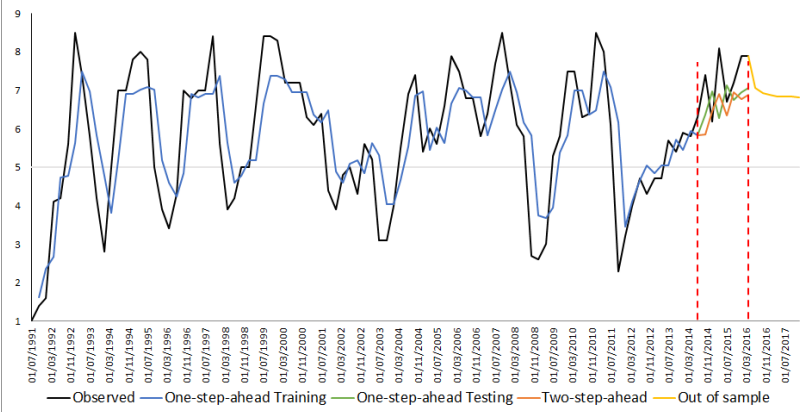

(k) Switzerland

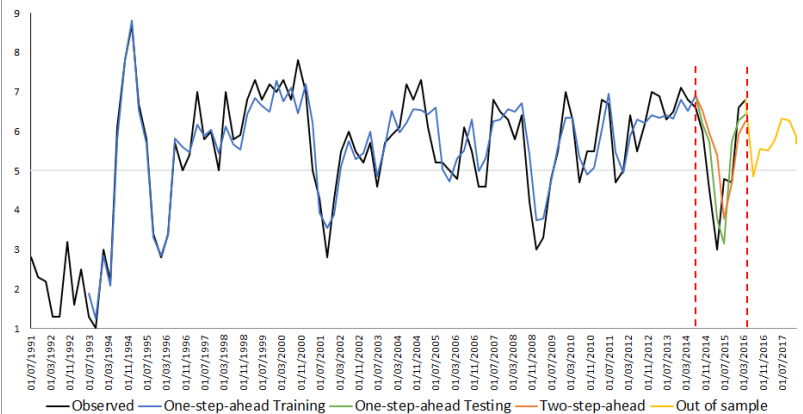

(l) Thailand

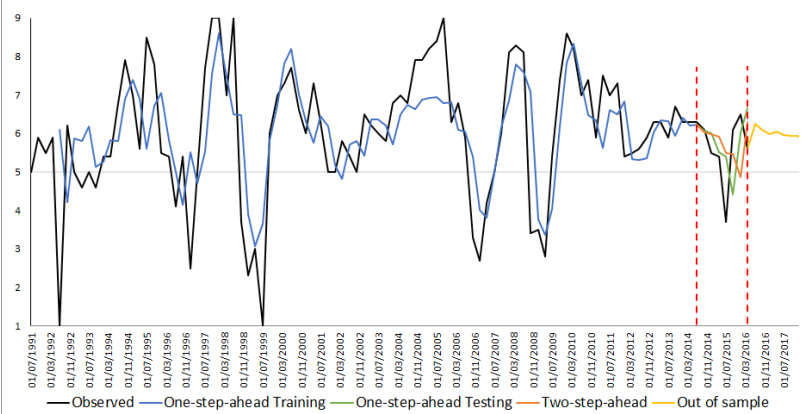

B.4. ARIMA

In the ARIMA modeling, various tests were performed before modeling the series in order to understand the generating data process and find the best $(p,d,q)(P,D,Q)$ order suit to the series. We began to perform the Augmented Dickey-Fuller (ADF) test (see Dickey and Fuller, 1981) and the Kwiatkowski, Phillips, Schmidt, and Shin (KPSS) test (see Kwiatkowski et al., 1992) to find the differentiation order (Table 16). In the Dickey-Fuller test, we started including the trend and constant over the regression for which all the series rejected the null hypothesis of the unit root. For the KPSS test, like the ADF test, we included the trend and constant terms and almost all the series did not reject the null hypothesis of stationary except for Switzerland and Norway, where the Switzerland series became stationary after the first 8 observations were excluded from the tests. To find the seasonal difference order, the Canova-Hansen test (see Canova and Hansen, 1995) was implemented, which has a null hypothesis of no unit roots at seasonal frequencies. This test complements the HEGGY test of seasonal unit roots.

Once the difference orders were determined and the respective transformations were applied, such as applying logarithms if necessary, we proceed to explore the autocorrelation function, partial autocorrelation, extended autocorrelation function, and information criterion AIC and BIC. We used these factors to find the autoregressive and moving average coefficients. A group of possible models were tested on each country, for which the most suitable model had to accomplish five conditions:

- Low BIC, AICc, and RMSE
- coefficients statistical different to zero.
- the residuals should be uncorrelated through time.
- the cross-correlation function between the predicted errors and the observed time series should be close to zero.
- The high order closest model should fail in comparison.

Then, after we found the best ARIMA model possible, we forecast one step ahead and two step ahead on the testing set and calculate the respective MSE to compare with the NAR-NN Model.

Table 16. Unit Root, Stationarity Tests and Model Identification

	ADF t-Stat	KPSS Stat	(p,d,q)(P,D,Q) order
Brazil	5.871	0.089	(1,0,0)
Canada	5.357	0.040	(1,0,0)
Switzerland	4.085	0.188	(2,0,1)
Chile	3.377	0.143	(1,1,1)
Colombia*	4.892	0.059	(1,0,0)
Czech Republic*	4.431	0.086	(1,1,1)
United Kingdom	5.294	0.069	(1,0,0)(1,0,0)
Korea	4.997	0.065	(1,0,1)
Mexico	5.179	0.056	(1,1,1)
Norway	4.846	0.150	(1,1,1)
Hungary*	4.022	0.089	(1,0,0)
Philippines*	6.370	0.077	(1,0,0)
Poland*	3.537	0.122	(0,1,2)
Sweden	5.545	0.065	(2,0,0)
Thailand*	4.928	0.045	(1,0,0)
South Africa	5.515	0.044	(1,0,0)(1,0,0)
Test critical values:			
1% level	-4.04	0.216	
5% level	-3.45	0.146	
10% level	-3.15	0.119	
*Log transformation			