

Safarian, Sahar; Aramoun, Fereshteh

Article

Energy and exergy assessments of modified Organic Rankine Cycles (ORCs)

Energy Reports

Provided in Cooperation with:

Elsevier

Suggested Citation: Safarian, Sahar; Aramoun, Fereshteh (2015) : Energy and exergy assessments of modified Organic Rankine Cycles (ORCs), Energy Reports, ISSN 2352-4847, Elsevier, Amsterdam, Vol. 1, pp. 1-7,
<https://doi.org/10.1016/j.egyr.2014.10.003>

This Version is available at:

<https://hdl.handle.net/10419/187809>

Standard-Nutzungsbedingungen:

Die Dokumente auf EconStor dürfen zu eigenen wissenschaftlichen Zwecken und zum Privatgebrauch gespeichert und kopiert werden.

Sie dürfen die Dokumente nicht für öffentliche oder kommerzielle Zwecke vervielfältigen, öffentlich ausstellen, öffentlich zugänglich machen, vertreiben oder anderweitig nutzen.

Sofern die Verfasser die Dokumente unter Open-Content-Lizenzen (insbesondere CC-Lizenzen) zur Verfügung gestellt haben sollten, gelten abweichend von diesen Nutzungsbedingungen die in der dort genannten Lizenz gewährten Nutzungsrechte.

Terms of use:

Documents in EconStor may be saved and copied for your personal and scholarly purposes.

You are not to copy documents for public or commercial purposes, to exhibit the documents publicly, to make them publicly available on the internet, or to distribute or otherwise use the documents in public.

If the documents have been made available under an Open Content Licence (especially Creative Commons Licences), you may exercise further usage rights as specified in the indicated licence.



<https://creativecommons.org/licenses/by-nc-nd/4.0/>

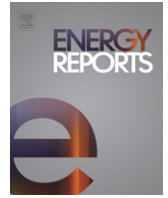

Energy and exergy assessments of modified Organic Rankine Cycles (ORCs)



Sahar Safarian*, Fereshteh Aramoun

Department of Energy Engineering, Sharif University of Technology, Tehran, P.O. Box 11365-11155, Iran

ARTICLE INFO

Article history:

Received 30 August 2014

Received in revised form

7 October 2014

Accepted 16 October 2014

Available online 9 January 2015

Keywords:

Exergy analysis

Organic Rankine Cycle

Regeneration

Turbine bleeding

ABSTRACT

This paper presents a theoretical framework for the energy and exergy evaluation of a basic as well as three modified Organic Rankine Cycles (ORCs). The modified ORCs considered incorporating turbine bleeding, regeneration and both of them. The results demonstrate that evaporator has major contribution in the exergy destruction which is improved by increase in its pressure. The results confirm that the integrated ORC with turbine bleeding and regeneration has the highest thermal and exergy efficiencies (22.8% and 35.5%) and the lowest exergy loss (42.2 kW) due to decrease in cold utility demand and high power generation.

© 2014 The Authors. Published by Elsevier Ltd.

This is an open access article under the CC BY-NC-ND license (<http://creativecommons.org/licenses/by-nc-nd/4.0/>).

Nomenclature

DTP	degree of thermodynamic perfection (α)
E	exergy (kJ)
e	specific exergy (kJ/kg)
H	enthalpy (kJ)
h	specific enthalpy (kJ/kg)
m	mass flow rate (kg/s)
P	Pressure (kPa)
Q	required heat
R	specific gas constant (kJ/kg K)
s	specific entropy (kJ/kg K)
T	temperature (K)
W	work (kJ)
X	mass flow into feed-water
β	influence coefficient
φ	exergy loss
η	Efficiency

1. Introduction

Energy consumption is increasing and the rapid industrialization leads to global warming and environmental deterioration. In

order to meet future energy demand while reducing greenhouse gas emissions and dependence on fossil fuels, development of energy systems is inescapable. Study shows that more than 50% of the total heat generated in industry is the low grade heat and is wasted as the thermal pollution.

Among many well-proven technologies, Organic Rankine Cycle (ORC) is considered to be an effective solution for low and medium temperature (300–450 °C) heat recovery for power production. The important advantage of ORC is that it can be successfully used in various fields of biomass combustion, geothermal systems, solar desalination systems, and it is extremely beneficial when the exhaust gases of the gas turbine are at low temperature. High reliability and flexibility also contribute at making the value proposition of ORC particularly attractive (Bombarda et al., 2010; Munoz de Escalona et al., 2012; Chacartegui et al., 2011; Karellas et al., 2012; Sun and Li, 2011; Wei et al., 2008; W. Li et al., 2011; J. Li et al., 2011).

Quoilin et al. (2011) focused both on the thermodynamic and economic optimization of a small-scale ORC in waste heat recovery application. Sun and Li (2011) optimized the performance of an ORC based on two objective functions. They demonstrated that the controlled variables and uncontrolled variables are linear function for maximizing the total net power generation and quadratic function for maximizing the system thermal efficiency.

In addition, there are some methods that can improve an ORC system performance, such as system operating optimization, combining feed-water heating, integrating with other system techniques and incorporating turbine bleeding and regeneration. In this way, Mago et al. (2008) and Desai and Bandyopadhyay (2009) have

* Corresponding author. Tel.: +98 21 22374487.

E-mail address: safarian@energy.sharif.edu (S. Safarian).

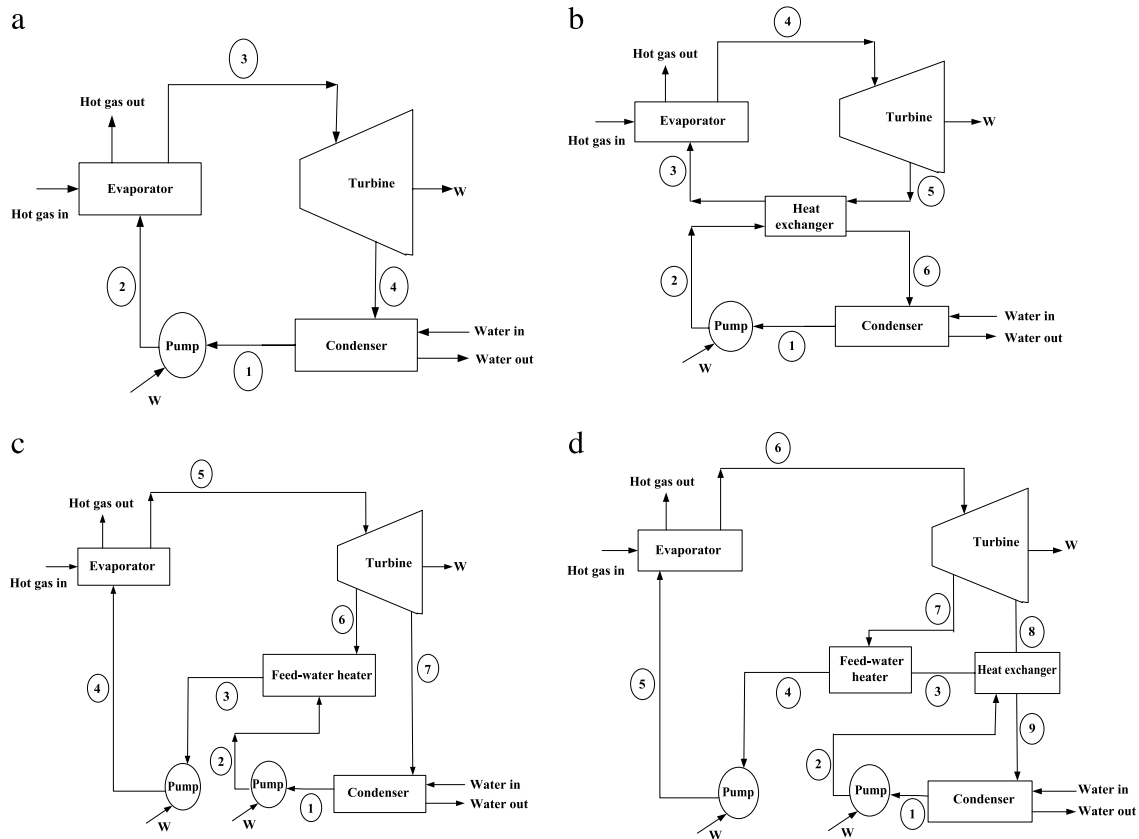

Fig. 1. Schematic diagram of (a) basic ORC, (b) modified ORC incorporating turbine bleeding, (c) regenerative ORC and (d) modified ORC incorporating both turbine bleeding and regeneration.

shown that the thermal efficiency of an ORC can be significantly improved by incorporating turbine bleeding and regeneration, as it investigate in this paper.

Despite various studies concerning ORC like system performance modeling, selection of an appropriate working fluid, optimization, and etc., detailed energy and exergy analysis of the basic and different modified ORC cycles were rarely found. Energy analysis is the most commonly-used method for evaluation of energy conversion processes. However, it has some inherent limitations like not characterizing the energy quality and irreversibility of processes through the system. In contrast, exergy analysis will characterize the work potential of the systems. It provides a more realistic view of various devices and processes for evaluation of efficiency and exergy losses in order to locate the largest margins for improvements (Xu et al., 2011; Dai et al., 2009; Regulgadda et al., 2010; Aljundi, 2009; Sagastume Gutiérrez et al., 2013).

In this regard, the objective of this paper is to construct a theoretical framework for the energy and exergy analysis of the ORC, which can be used to evaluate the energy and exergy efficiencies and exergy destruction in each component and in the overall system. In addition to the basic ORC, three modified ORCs with regeneration and turbine bleeding are investigated to improve the system performance. This paper will identify major sources of loss and exergy destruction in the power plant. Finally, a parametric study is performed to determine how the system performance varies with different operating parameters.

2. Thermodynamic approaches

Schematics of a basic and modified cycles of ORC systems are shown in Fig. 1. As observed in Fig. 1(a), there are four different processes: Process 1–2 (pumping process), Process 2–3 (constant pressure heat addition), Process 3–4 (expansion process), and

Process 4–1 (constant pressure heat removal). Fig. 1(b) shows a modified ORC incorporating turbine bleeding. Because the turbine outlet temperature is markedly higher than the condenser outlet temperature, implement of an internal heat exchanger (IHE) into the cycle is rewarded. For a modified ORC with regeneration (Fig. 1(c)), a feed-water heater is incorporated into the ORC. The vapor extracted from the turbine mixes with the feed-water exiting the pump. Ideally the mixture leaves the heater as a saturated liquid at the heater pressure. In addition, schematic of a modified ORC incorporating both regeneration and turbine bleeding is shown in Fig. 1(d).

The equations used to evaluate the basic and modified ORCs are presented in Table 1. The topological methodology of Mago et al. (2008), Arslan and Yetik (2011), Dai et al. (2009) and Desai and Bandyopadhyay (2009) will be utilized to perform an energy and exergy analysis of ORC.

3. Exergy analysis

Exergy is a measure of the maximum capacity of a system to perform useful work as it proceeds to a specified final state in equilibrium with its surroundings. Exergy is generally not conserved as energy but destroyed in the system. Exergy destruction is the measure of irreversibility that is the source of performance loss. Therefore, an exergy analysis assessing the magnitude of exergy destruction identifies the location, the magnitude and the source of thermodynamic inefficiencies in a thermal system (Aljundi, 2009). Exergy flow rate of a system is composed of kinetic, potential, physical and chemical one (Aljundi, 2009; Sagastume Gutiérrez et al., 2013):

$$E = \dot{E}_k + \dot{E}_p + \dot{E}_{ph} + \dot{E}_{ch} \quad (1)$$

Table 1
Thermodynamic equations to evaluate ORCs.

Component	Equation
Basic ORC	
Pump (1–2)	$\dot{W}_P = \frac{\dot{W}_{P,ideal}}{\eta_P} = \dot{m} \frac{(h_2 - h_1)}{\eta_P}$
Evaporator (2–3)	$\dot{Q}_e = \dot{m}(h_3 - h_2)$
Turbine (3–4)	$\dot{W}_T = \dot{W}_{T,ideal} \eta_T = \dot{m}(h_3 - h_4)\eta_T$
Condenser (4–1)	$\dot{Q}_c = \dot{m}(h_4 - h_1)$
Cycle efficiency	$\eta_{cycle} = \frac{\dot{W}_P + \dot{W}_T}{\dot{Q}_e}$
ORC incorporating turbine bleeding	
Internal heat exchanger (2–3 & 5–6)	$\dot{Q}_h = \dot{m}(h_5 - h_6)$
Pump (1–2)	$\dot{W}_P = \frac{\dot{W}_{P,ideal}}{\eta_P} = \dot{m} \frac{(h_2 - h_1)}{\eta_P}$
Evaporator (3–4)	$\dot{Q}_e = \dot{m}(h_4 - h_3)$
Turbine (4–5)	$\dot{W}_T = \dot{W}_{T,ideal} \eta_T = \dot{m}(h_4 - h_5)\eta_T$
Condenser (6–1)	$\dot{Q}_c = \dot{m}(h_6 - h_1)$
Cycle efficiency	$\eta_{cycle} = \frac{\dot{W}_P + \dot{W}_T}{\dot{Q}_e}$
ORC incorporating to regeneration	
Feed-water heater (6–3–2)	$X = \frac{h_3 - h_2}{h_6 - h_2}$
Pump (1–2 & 3–4)	$\dot{W}_P = \dot{m} \left[\frac{(1-X)(h_1 - h_2) + (h_3 - h_4)}{\eta_P} \right]$
Evaporator (4–5)	$\dot{Q}_e = \dot{m}(h_5 - h_4)$
Turbine (5–6 & 5–7)	$\dot{W}_T = \dot{W}_{T,ideal} \eta_T = \dot{m} \eta_T [(h_5 - h_7) + X(h_7 - h_6)]$
Condenser (7–1)	$\dot{Q}_c = \dot{m}(1-X)(h_1 - h_7)$
Cycle efficiency	$\eta_{cycle} = \frac{\dot{W}_P + \dot{W}_T}{\dot{Q}_e}$
ORC incorporating turbine bleeding and regeneration	
Internal heat exchanger (2–3 & 8–9)	$\dot{Q}_h = \dot{m}(1-X)(h_8 - h_9)$
Feed-water heater (7–4–3)	$X = \frac{h_4 - h_3}{h_7 - h_3}$
Pump (1–2 & 4–5)	$\dot{W}_P = \dot{m} \left[\frac{(1-X)(h_1 - h_2) + (h_4 - h_5)}{\eta_P} \right]$
Evaporator (5–6)	$\dot{Q}_e = \dot{m}(h_6 - h_5)$
Turbine (6–7 & 6–8)	$\dot{W}_T = \dot{W}_{T,ideal} \eta_T = \dot{m} \eta_T [(h_6 - h_8) + X(h_8 - h_7)]$
Condenser (9–1)	$\dot{Q}_c = \dot{m}(1-X)(h_1 - h_9)$
Cycle efficiency	$\eta_{cycle} = \frac{\dot{W}_P + \dot{W}_T}{\dot{Q}_e}$

And the specific exergy rate is:

$$e = e_k + e_p + e_{ph} + e_{ch} \quad (2)$$

$$e = \frac{\dot{E}}{\dot{m}} \quad (3)$$

In this study the kinetic (e_k) and potential (e_p) exergy are assumingly negligible. The value of physical exergy for steam and water at various points in the objective system can be calculated by the following equation:

$$e_{ph} = h - h_0 - T_0(s - s_0) \quad (4)$$

And for ideal gas,

$$e_{ph} = h - h_0 - T_0 \left[s - s_0 - R \ln \left(\frac{P}{P_0} \right) \right] \quad (5)$$

where h and s are specific enthalpy and entropy of the substance, respectively, and h_0 and s_0 are those at the state determined temperature and pressure (T_0 and P_0).

The chemical exergy of organic substance could be calculated from:

$$e_{ch} = \frac{e_{ch}^0}{M} \left[\frac{T_0}{298.15} \right] + \frac{\Delta H_0}{M} \left[\frac{T_0 - 298.15}{298.15} \right] \quad (6)$$

where ΔH_0 and e_{ch}^0 are standard enthalpy of devaluation and exergy of organic substance, respectively.

For the comprehensive exergy analysis, some important parameters are also calculated. The parameters are as follows (Mago et al., 2008) and (Nikulshin et al., 2006):

1-Degree of thermodynamic perfection (α):

α_i is the ratio of the outlet exergy of element i (E_i^{out}) to the exergy flow into the element i (E_i^{in}). It can be expressed as:

$$\alpha_i = \frac{E_i^{out}}{E_i^{in}} = 1 - \frac{\varphi_i}{E_i^{in}} \quad (7)$$

where φ_i is the exergy loss of element i :

$$\varphi_i = E_i^{in} - E_i^{out} \quad (8)$$

Ideally α of any element should be 1, which it will happen only when the exergy loss of the element is zero. Consequently, the higher degree of thermodynamic perfection of any element is the better performance of it.

The total exergy loss and degree of thermodynamic perfection of the system are as follows:

$$\varphi_{total} = \sum_{i=1}^n \varphi_i \quad (9)$$

$$\alpha_{total} = \frac{E_{total}^{out}}{E_{total}^{in}} \quad (10)$$

2-Exergy efficiency

The exergy efficiency of element i is defined as the ratio of used exergy of element i (E_i^u) to the available exergy of the same element (E_i^a):

$$\eta_{exergy}^i = \frac{E_i^u}{E_i^a} \quad (11)$$

The available and used exergy of different elements of ORC system are presented in Table 2. Obviously the higher exergy efficiency of any element is the better performance of that element.

The total exergy efficiency of system is the ratio of its total used exergy to total available exergy. It can be determined as:

$$\eta_{exergy,total} = \frac{E_{total}^u}{E_{total}^a} \quad (12)$$

3-Influence coefficient

The influence coefficient of element i is defined as the ratio of the available exergy for element i to the total available exergy of the system (E_{total}^a):

$$\beta_i = \frac{E_i^a}{E_{total}^a} \quad (13)$$

Actually β is the weight of any element in the total system performance. This parameter identifies the elements of the system which has the most impact on the system efficiencies.

4. Thermodynamic assumptions

The considered working fluid for ORC is R-113 which has been proved to be a good candidate for ORC applications (Mago et al., 2008) and (Badr and Ocallaghan et al., 1990; Gu et al., 2009). The evaporator pressure and condenser temperature are fixed at 2.5 MPa and 298 K, respectively. The isentropic efficiencies of the turbine and pump are 80 and 85%, respectively. The ORC receives heat from a heat source at a rate of 252 kW. The considered inlet hot gas to the evaporator is a steady stream of nitrogen at the temperature of 573 K and the pressure of 0.1 MPa. The determined temperature and pressure for the reference state are 298 K and 0.1 MPa. For the modified ORC with regeneration, the intermediate pressure of 1 MPa was assumed. Also, both pumps run at the same efficiency despite operating at different flow conditions. In addition, to perform thermodynamic analysis of the ORCs, steady state condition and no pressure drop and heat losses in any equipment are assumed.

Table 2
Used and available exergies of the different components of an ORC (Sagastume Gutiérrez et al., 2013).

Component	Pump	Turbine	Heat exchanger
Schematic			
Used exergy	$E_2 - E_1$	W	$E_2 - E_1$
Available exergy	W	$E_1 - E_2 - E_3$	$E_3 - E_4$

Table 3
Flow parameters for the basic ORC and ORC incorporating turbine bleeding.

Basic ORC					ORC to turbine bleeding			
Points	T (°C)	P (MPa)	e (kJ/kg)	E (kW)	T (°C)	P (MPa)	e (kJ/kg)	E (kW)
1	25	0.046	0	0	25	0.048	0	0
2	26.1	2.5	1.642	1.74	26.1	2.5	1.77	2.05
3	195	2.5	64.02	68.03	55	2.5	4.16	4.81
4	87	0.046	3.64	3.85	195	2.5	64.02	75.45
5	300	0.1	82	163.7	92	0.048	5.08	5.87
6	183	0.1	30.38	60.52	56	0.048	1.73	2.008
7	25	0.1	0	0	300	0.1	82	167.34
8	35	0.1	0.68	3.21	184	0.1	30.89	61.78
9					25	0.1	0	0
10					35	0.1	0.38	1.75

Table 4
Flow parameters for the ORC incorporating to regeneration and ORC incorporating both turbine bleeding and regeneration.

ORC incorporating to regeneration					ORC incorporating both turbine bleeding and regeneration			
Points	T (°C)	P (MPa)	e (kJ/kg)	E (kW)	T (°C)	P (MPa)	e (kJ/kg)	E (kW)
1	25	0.048	0	0	25	0.048	0	0
2	25.4	1	0.65	0.66	25.4	1	0.67	0.712
3	138.3	1	17.462	34.74	40	1	2.08	2.21
4	141.2	2.5	19.044	37.89	138.3	1	16.938	32.48
5	195	2.5	62.02	124.7	140.2	2.5	18.328	35.15
6	154.6	1	51.62	49.81	195	2.5	62.02	121.2
7	90	0.048	3.66	3.75	157.3	1	53.22	45.44
8	300	0.1	82	173.6	92	0.048	5.08	5.40
9	188	0.1	32.21	67.64	74	0.048	3.314	3.52
10	25	0.1	0	0	300	0.1	82	172.5
11	35	0.1	0.68	3.13	189	0.1	33.21	69.74
12					25	0.1	0	0
13					35	0.1	0.68	3.06

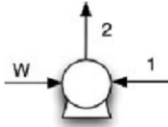
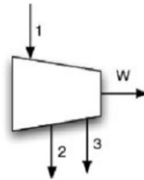
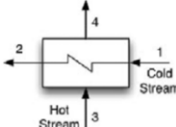
5. Results

5.1. Exergy evaluation

For calculation of exergy flow rates of the system, the operating conditions of the flows are needed. Tables 3–4 present the flow parameter data for basic ORC and the modified ORCs. The tables include pressure, temperature, specific exergy, and exergy rate associated with each of the components.

Using the information provided in Tables 3–4, the evaporator heat rate, the condenser heat removal rate, the organic fluid mass flow rate, the pump power and the turbine power can be determined. All these values are arranged in Table 5 for the basic and modified ORCs.

Tables 6–9 present the thermodynamic characteristics of the analyzed basic and modified ORCs, respectively. The tables include parameters such as inlet and outlet exergy, exergy loss, used and available exergy, exergy efficiency, degree of thermodynamic perfection, and coefficient of influence associated with

Table 5
Performance parameters of the basic and modified ORCs.

		ORC (a)	ORC (b)	ORC (c)	ORC (d)
Evaporator duty	kW	252	252	252	252
Condenser duty	kW	202	196	199	194.6
Turbine power	kW	51	56.5	59.45	61
Pump power	kW	1.96	2.2	3.92	3.46
Heat exchanger duty	kW	–	30.5	–	14
Net power	kW	49.04	54.3	55.53	57.54
Thermal efficiency	%	19.46	21.5	22	22.83
Mass flow (organic fluid)	kg/s	1.06	1.15	1.99	1.91
Mass flow into feed water	kg/s	–	–	0.96	0.85
Mass flow (water)	kg/s	4.68	4.51	4.61	4.51
Mass flow (gas)	kg/s	2	2	2.1	2.1

(a): basic ORC (b): ORC to turbine bleeding (c): ORC to regeneration (d): ORC to turbine bleeding and regeneration.

each component. In addition, the exergy loss, degree of thermodynamic perfection, and exergy efficiency for the total system are presented.

Table 6
Exergy evaluation of the basic ORC.

Element	E_i^{in} (kW)	E_i^{out} (kW)	ϕ_i (kW)	E_i^u (kW)	E_i^a (kW)	α_i (%)	β_i (%)	η_{exergy}^i (%)
Pump	1.96	1.74	0.219	1.74	1.96	88.8	1.198	88.80
Evaporator	165.41	128.55	37	66.29	103.17	77.7	63.10	
Turbine	68.03	54.85	13.2	51	64.17	80.63	39.25	79.47
Condenser	3.85	3.21	0.647	3.21	3.85	83.2	2.36	83.20
Total system	165.66	114.73	50.92	51	163.48	69.2	–	

Table 7
Exergy evaluation of the ORC incorporating turbine bleeding.

Element	E_i^{in} (kW)	E_i^{out} (kW)	Φ_i (kW)	E_i^u (kW)	E_i^a (kW)	α_i (%)	β_i (%)	η_{exergy}^i (%)
Pump	2.2	2.05	0.146	2.05	2.2	93.34	0.012	93.34
Evaporator	172.151	137.23	34.9	70.64	105.56	79.7	62.11	66.92
Turbine	75.454	62.37	13.08	56.5	69.58	82.66	40.94	81.19
Condenser	2.008	1.75	0.25	1.75	2.008	87.4	1.18	87.4411
Heat exchanger	7.93	6.82	1.109	2.75	3.86	86	2.27	71.32177
Total system	169.54	120.03	49.50	56.5	169.9	70.8	–	33.24

Table 8
Exergy evaluation of the ORC incorporating to regeneration.

Element	E_i^{in} (kW)	E_i^{out} (kW)	Φ_i (kW)	E_i^u (kW)	E_i^a (kW)	α_i (%)	β_i (%)	η_{exergy}^i (%)
Pump-1	37.93	37.89	0.041	3.148	3.19	99.88	0.018	98.68
Evaporator	211.5	192.41	19.09	86.87	105.96	90.9	61.29	
Turbine	124.77	113.01	11.75	59.45	71.20	90.5	41.19	83.48
Condenser	3.75	3.13	0.61	3.134	3.75	83.56	2.17	83.56
Pump-2	0.7	0.66	0.033	0.66	0.7	95.17	0.404	95.17
Feed water	50.47	34.74	15.73	34.74	50.47	68.8	29.20	68.83
Total system	177.52	130.22	47.30	59.45	172.86	73.35	–	

Table 9
Exergy evaluation of the ORC incorporating both turbine bleeding and regeneration.

Element	E_i^{in} (kW)	E_i^{out} (kW)	Φ_i (kW)	E_i^u (kW)	E_i^a (kW)	α_i (%)	β_i (%)	η_{exergy}^i (%)
Pump-1	35.18	35.15	0.033	2.66	2.7	99.9	0.015	98.74
Evaporator	207.7	190.9	16.7	86.10	102.81	92	59.85	83.74
Turbine	121.25	111.8	9.4	61	70.4	92.24	40.98	86.64
Condenser	3.52	3.06	0.45	3.06	3.52	86.97	2.052	86.97
Pump-2	0.76	0.71	0.047	0.712	0.76	93.8	0.442	93.8
Heat exchanger	6.11	5.73	0.37	1.50	1.879	93.8	3.942	79.84
Feed water	47.66	32.48	15.17	32.48	47.66	68.15	27.74	68.15
Total system	176.02	133.8	42.2	61	171.76	76.02	–	35.5

From the presented results (Tables 6–9), it can be inferred that the basic ORC has the lowest exergy efficiency (31.2%) and the highest total exergy loss (50.9 kW). And also, the biggest part of the system exergy loss is related to evaporator. On the other hand it is concluded that the evaporator is the critical element in the ORC cycle (W. Li et al., 2011), due to the fact that evaporator has the highest exergy loss and influence coefficient in comparison with other components of the cycle. The exergy loss in the evaporator is mainly due to the irreversibility associated with heat transfer over a finite temperature difference (Mago et al., 2008). In the basic ORC, exergy loss of evaporator is 37 kW and it is reduced by the modified ORCs incorporating turbine bleeding (ORC (b)), incorporating to regeneration (ORC (c)) and incorporating both turbine bleeding and regeneration (ORC (d)), 5.5%, 48.5% and 55%, respectively. This reduction in the exergy loss causes an improvement on the evaporator exergy efficiency from 64.2% (for the basic ORC) to 66.9%, 81.9% and 83.7% for the modified ORCs (b), (c) and (d), respectively. It is due to the used exergy in the evaporator increases for the modified cycles compared with the basic case. In addition, the decrease in the exergy loss entails an increase in the degree of thermodynamic perfection (DTP) from 77.7% (ORC (a)) to 79.7%, 90.9% and 92% for the ORCs (b), (c) and (d), respectively.

The most important result of energy and exergy analysis of the various ORCs is that the integrated ORCs with feed-water heater (ORCs (c) and (d)) show higher thermal and exergy efficiencies. Because the temperature of the evaporator feed is increased by bleeding of the working fluid from the turbine and mixing it with the evaporator feed in a direct contact heater. Moreover, an ORC with an internal heat exchanger (regenerator) and a direct contact heater presents the maximum thermal and exergy efficiencies (22.8% and 35.5%) among the evaluated cycles, in the same heat rate available for the evaporator from a hot gas stream (252 kW). On account of integration of an ORC with turbine bleeding and regeneration proposes additional benefits such as decrease in cold utility demand and generation of high power. However, it may be noted that the capital cost of the overall system and the complexity of the flow scheme are increased due to integration. In this way the high thermodynamic efficiency of ORC (d) makes decrease in the total system exergy loss (42.2 kW) and improvement on the degree of thermodynamic perfection (76%).

From the factor of coefficient of influence in Tables 6–9, it can be clearly seen, that turbine is the second component that has more impact on the ORC performance. It displays the second highest coefficient of influence. The exergy loss of turbine for the basic ORC

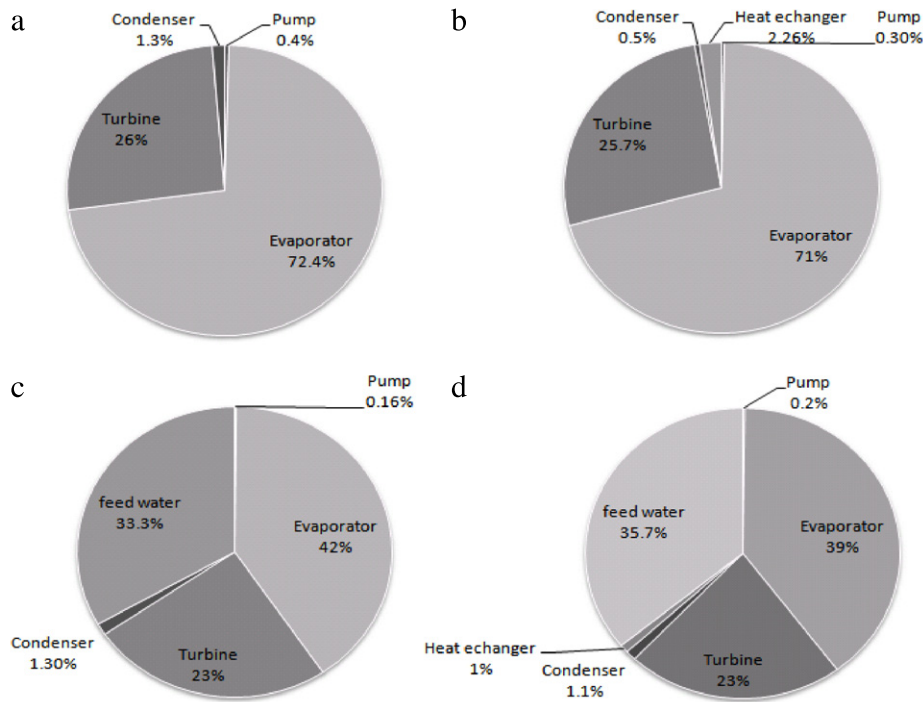

Fig. 2. Percentage of the exergy destroyed in each component.

is 13.2 kW and it is descended in the modified ORCs (b), (c) and (d) by 0.9%, 11% and 29%, respectively.

To reach a deep understanding of exergy losses for other elements of the mentioned ORC cases, the percentage of the exergy destroyed in each component with respect to the total system exergy loss for four configurations are depicted in Fig. 2. Fig. 2 proves that the evaporator and turbine are the components with the highest exergy losses contribution, respectively. In addition it can be seen that the ORCs (c) and (d) represent the lower exergy loss of evaporator. This exergy reduction is mainly due to the presence of the feed-water heater (33.5% and 35.7% of exergy losses for ORCs (c) and (d), respectively).

5.2. Effect of evaporator pressure on the ORCs performance

The variations of the thermal and exergy efficiencies against the evaporator pressure, for four ORC cases are shown in Fig. 3. The turbine inlet temperature at saturated conditions and other operating conditions are same as before section. From Fig. 3 it can be inferred that for all ORC configurations the thermal efficiency increases with the increase in evaporator pressure from 1.8 to 3 MPa. While the integrated ORC to internal heat exchanger and feed-water heater presents the maximum efficiency compared to other cycles, it shows an increase in the thermal efficiency of 21.6%–23.5% for the lowest and highest turbine inlet pressures, respectively.

In Fig. 3, the exergy efficiency also increases with evaporator pressure increasing, and the ORC (d) is still the highest, ORCs (c) and (b) are the second and third highest and the basic ORC has the lowest exergy efficiency. The exergy efficiency becomes larger because of reduction in the system total exergy loss with the increment in the evaporator pressure, which is shown in Fig. 4. Since the evaporator pressure is increased, the discrepancy between the evaporator temperature and the hot gas stream temperature entering the evaporator is reduced. This reduction in the temperature difference leads to increment in the used exergy and it causes an improvement in the exergy efficiency or a decrease in the system exergy loss.

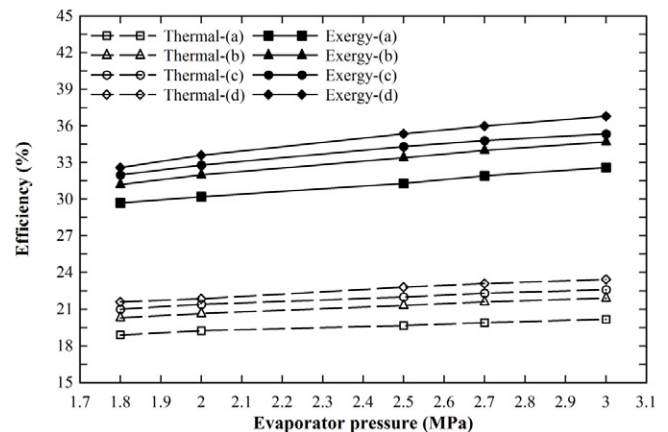

Fig. 3. Variations of the thermal and exergy efficiencies versus evaporator pressure.

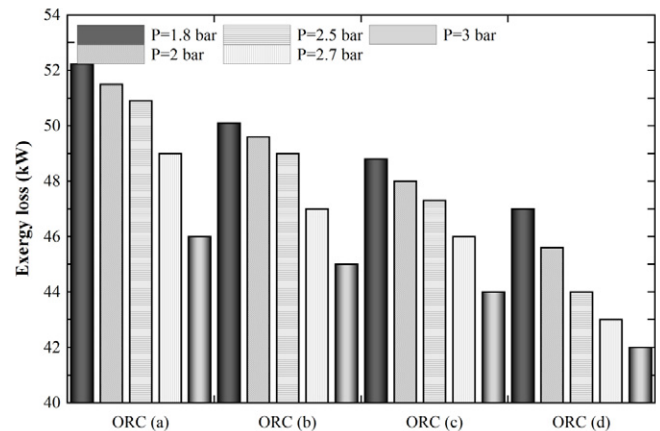

Fig. 4. Variations of the exergy loss versus evaporator pressure.

Moreover, the lessening in the exergy loss entails a growth in the degree of thermodynamic perfection (DTP) of the system. The

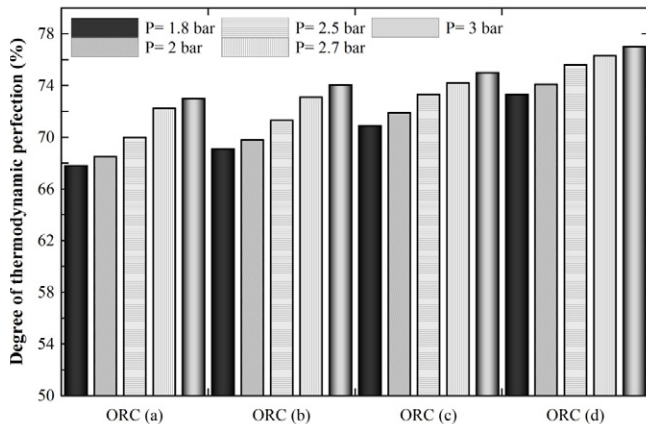

Fig. 5. Variations of DTP of total system versus evaporator pressure.

variations of overall system DTP against evaporator pressure are depicted in Fig. 5.

6. Conclusions

This paper presents a detailed energy and exergy analysis of a basic as well as three modified Organic Rankine Cycles (ORCs) using R-113 as working fluid. The modified ORCs considered incorporating turbine bleeding (ORC (b)), regeneration (ORC (c)) and both of them (ORC (d)). For a comprehensive thermodynamic analysis, some important parameters such as degree of thermodynamic perfection, exergy efficiency, and influence coefficient are also calculated.

The results show that the basic ORC has the lowest exergy efficiency (31.2%) and the highest total exergy loss (50.9 kW). And the biggest part of the system exergy loss is related to evaporator (37 kW). The modified ORCs (b), (c) and (d) improve the evaporator exergy losses by 5.5%, 48.5% and 55%, respectively. It is due to increase in evaporator feed temperature by bleeding with working fluid from the turbine in a direct contact heater. Reduction in the total exergy losses by modified ORCs lead to increment in the overall system exergy efficiency by 6.5%, 10% and 14%, respectively.

The integrated ORC to regenerator and a feed-water heater (ORC (d)) presents the maximum thermal and exergy efficiencies (22.8% and 35.5%) among the evaluated cycles, on account of additional benefits such as decrease in cold utility demand and generation of high power. Consequently the total system exergy loss is decreased in 42.2 kW and the degree of thermodynamic perfection is improved to 76%.

The results show that for four cycles the thermal and exergy efficiencies increase and the system exergy loss decreases with the evaporator pressure increasing. In this way the discrepancy between the evaporator temperature and the hot gas stream temperature entering the evaporator is reduced. So the used exergy and the exergy efficiency are improved.

References

- Aljundi, I.H., 2009. Energy and exergy analysis of a steam power plant in Jordan. *Appl. Therm. Eng.* 29, 324–328.
- Arslan, O., Yetik, O., 2011. ANN based optimization of supercritical ORC-Binary geothermal power plant: Simav case study. *Appl. Therm. Eng.* 31, 3922–3928.
- Badr, O., Ocallaghan, P.W., et al., 1990. Rankine-cycle systems for harnessing power from low-grade energy-Sources. *Appl. Eng.* 36, 263–292.
- Bombarda, P., Invernizzi, C.M., Pietra, C., 2010. Heat recovery from diesel engines: A thermodynamic comparison between Kalina and ORC cycles. *Appl. Therm. Eng.* 30, 212–219.
- Chacartegui, R., Muñoz de Escalona, J.M., Sánchez, D., Monje, B., Sánchez, T., 2011. Alternative cycles based on carbon dioxide for central receiver solar power plants. *Appl. Therm. Eng.* 31, 872–879.
- Dai, Y.P., Wang, J.F., Gao, L., 2009. Exergy analysis, parametric analysis and optimization for a novel combined power and ejector refrigeration cycle. *Appl. Therm. Eng.* 29, 1983–1990.
- Dai, Y., Wang, J., Gao, L., 2009. Parametric optimization and comparative study of organic Rankine cycle (ORC) for low grade waste heat recovery. *Eng. Convers. Manage.* 50, 576–582.
- Desai, N.B., Bandyopadhyay, S., 2009. Process integration of organic Rankine cycle. *Eng.* 34, 1674–1686.
- Gu, W., Wang, Y., Wang, Y., Zheng, B., 2009. Theoretical and experimental investigation of an Organic Rankine Cycle for a waste heat recovery system. *Part A: J. Power. Eng.* 223, 523–533. *Proc. IMechE.*
- Karellas, S., Schuster, A., Leontaritis, A.D., 2012. Influence of supercritical ORC parameters on plate heat exchanger design. *Appl. Therm. Eng.* 33–34, 70–76.
- Li, W., Feng, X., Yu, L.J., Xu, J., 2011. Effects of evaporating temperature and internal heat exchanger on organic Rankine cycle. *Appl. Therm. Eng.* 31, 4014–4023.
- Li, J., Pei, G., Li, Y., Ji, J., 2011. Evaluation of external heat loss from a small-scale expander used in Organic Rankine cycle. *Appl. Therm. Eng.* 31, 2694–2701.
- Mago, P.J., Chamra, L.M., Srinivasan, K., Somayaji, C., 2008. An examination of regenerative organic rankine cycle using dry fluids. *Appl. Therm. Eng.* 28, 998–1007.
- Mago, P.J., Srinivasan, K.K., Chamra, L.M., Somayaji, C., 2008. An examination of exergy destruction in organic Rankine cycles. *Int. J. Eng. Res.* 32, 926–938.
- Muñoz de Escalona, J.M., Sánchez, D., Chacartegui, R., Sánchez, T., 2012. Part-load analysis of gas turbine & ORC combined cycles. *Appl. Therm. Eng.* 36, 63–72.
- Nikulshin, V., Bailey, M., Nikulshina, V., 2006. Thermodynamic analysis of air refrigerator on exergy graph. *Therm. Sci.* 10, 99–110.
- Quoilin, S., Declaye, S., Tchanche, B.F., Lemort, V., 2011. Thermo-economic optimization of waste heat recovery Organic Rankine Cycles. *Appl. Therm. Eng.* 31, 2885–2893.
- Regulagadda, P., Dincer, I., Naterer, G.F., 2010. Exergy analysis of a thermal power plant with measured boiler and turbine losses. *Appl. Therm. Eng.* 30, 970–976.
- Sagastume Gutiérrez, A., Cogollos Martínez, J.B., Vandecasteele, C., 2013. Energy and exergy assessments of a lime shaft kiln. *Appl. Therm. Eng.* 51, 273–280.
- Sun, J., Li, W., 2011. Operation optimization of an organic rankine cycle (ORC) heat recovery power plant. *Appl. Therm. Eng.* 31, 2032–2041.
- Wei, D., Lu, X., Lu, Z., Gu, J., 2008. Dynamic modeling and simulation of an Organic Rankine Cycle (ORC) system for waste heat recovery. *Appl. Therm. Eng.* 28, 1216–1224.
- Xu, Ch., Wang, Zh., Li, X., Sun, F., 2011. Energy and exergy analysis of solar power tower plants. *Appl. Therm. Eng.* 31, 3904–3913.