

Pereira, R. et al.

Article

Consumer energy management system with integration of smart meters

Energy Reports

Provided in Cooperation with:

Elsevier

Suggested Citation: Pereira, R. et al. (2015) : Consumer energy management system with integration of smart meters, Energy Reports, ISSN 2352-4847, Elsevier, Amsterdam, Vol. 1, pp. 22-29,
<https://doi.org/10.1016/j.egyr.2014.10.001>

This Version is available at:

<https://hdl.handle.net/10419/187804>

Standard-Nutzungsbedingungen:

Die Dokumente auf EconStor dürfen zu eigenen wissenschaftlichen Zwecken und zum Privatgebrauch gespeichert und kopiert werden.

Sie dürfen die Dokumente nicht für öffentliche oder kommerzielle Zwecke vervielfältigen, öffentlich ausstellen, öffentlich zugänglich machen, vertreiben oder anderweitig nutzen.

Sofern die Verfasser die Dokumente unter Open-Content-Lizenzen (insbesondere CC-Lizenzen) zur Verfügung gestellt haben sollten, gelten abweichend von diesen Nutzungsbedingungen die in der dort genannten Lizenz gewährten Nutzungsrechte.

Terms of use:

Documents in EconStor may be saved and copied for your personal and scholarly purposes.

You are not to copy documents for public or commercial purposes, to exhibit the documents publicly, to make them publicly available on the internet, or to distribute or otherwise use the documents in public.

If the documents have been made available under an Open Content Licence (especially Creative Commons Licences), you may exercise further usage rights as specified in the indicated licence.



<https://creativecommons.org/licenses/by-nc-nd/4.0/>

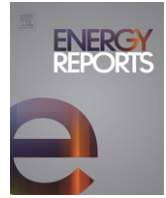

Consumer energy management system with integration of smart meters



R. Pereira^{a,d}, J. Figueiredo^{a,b,*}, R. Melicio^{a,b}, V.M.F. Mendes^{a,d}, J. Martins^c, J.C. Quadrado^d

^a CEM/IDMEC, Universidade Évora, R. Romão Ramalho, 59; 7000-671 Évora, Portugal

^b IDMEC, Instituto Superior Técnico, Technical University of Lisbon; 1049-001 Lisboa, Portugal

^c Centre of Technology and Systems/FCT, Universidade Nova Lisboa; 2829-516 Caparica, Portugal

^d ISEL, Instituto Superior de Engenharia de Lisboa, Department of Electrical Engineering and Automation, R. Conselheiro Emídio Navarro, 1959-007 Lisbon, Portugal

ARTICLE INFO

Article history:

Received 18 September 2014

Received in revised form

17 October 2014

Accepted 29 October 2014

Available online 14 January 2015

ABSTRACT

This paper develops an energy management system with integration of smart meters for electricity consumers in a smart grid context. The integration of two types of smart meters (SM) are developed: (i) consumer owned SM and (ii) distributor owned SM. The consumer owned SM runs over a wireless platform – ZigBee protocol and the distributor owned SM uses the wired environment – ModBus protocol. The SM are connected to a SCADA system (Supervisory Control And Data Acquisition) that supervises a network of Programmable Logic Controllers (PLC). The SCADA system/PLC network integrates different types of information coming from several technologies present in modern buildings.

The developed control strategy implements a hierarchical cascade controller where inner loops are performed by local PLCs, and the outer loop is managed by a centralized SCADA system, which interacts with the entire local PLC network.

In order to implement advanced controllers, a communication channel was developed to allow the communication between the SCADA system and the MATLAB software.

© 2014 The Authors. Published by Elsevier Ltd.

This is an open access article under the CC BY-NC-ND license (<http://creativecommons.org/licenses/by-nc-nd/4.0/>).

1. Introduction

The power grid is an aggregation of several networks and multiple generation companies which have different operators that use diverse levels of communication and coordination. The transition from traditional power grid towards smart grid is a movement from a static to a flexible infrastructure with improved observability, controllability and efficiency (Vijayapriya and Kothari, 2011). Smart grid implies a smart generation, smart transmission, smart storage and smart sensors.

Smart grid will promote a bidirectional flow of electric power and communication between consumers and suppliers, throughout the inclusion of information and communication technologies which contributes for the transformation of passive end-consumers into active players (Gangale et al., 2013).

It is considered essential to comprehend and engage consumers to assume their new role as active participants in the electricity system in a successful way. This consumer engagement also depends on the characteristics of the Information and Communication Technologies (ICT), which improvement is driven by consumers' needs, interests and benefits. ICT will play a vital role in smart grid. The smart grid objectives will not be achieved without a parallel developing of complex ICT systems (Melvin, 2014). The communication infrastructure should be simple, robust, secure and flexible in order to allow monitoring, management, control and dispatching operations from distribution to consumers (Vijayapriya and Kothari, 2011).

An intelligent smart home controller providing information about consumption patterns is useful to raise energy consumption awareness and to encourage consumers to real energy savings (Vijayapriya and Kothari, 2011). Among available products for residential end-user are smart appliances, smart meters and energy monitoring and control systems (Geelen et al., 2013).

Smart meters are digital electricity meters that accurately measures both electricity consumption and production and communicate this data to the energy supplier. These meters have the

* Corresponding author at: CEM/IDMEC, Universidade Évora, R. Romão Ramalho, 59; 7000-671 Évora, Portugal.

E-mail address: jfig@uevora.pt (J. Figueiredo).

<http://dx.doi.org/10.1016/j.egy.2014.10.001>

2352-4847/© 2014 The Authors. Published by Elsevier Ltd. This is an open access article under the CC BY-NC-ND license (<http://creativecommons.org/licenses/by-nc-nd/4.0/>).

ability to communicate the measured data, which provides them the “smart” aspect. Smart meters are predominantly used by energy suppliers as a contribution for more precise and automated billing. Smart meter also allows its integration in home energy management systems through communication protocols where the provided information is related to energy flow and price signals. Smart meters associated with their related infrastructures enable end-users to be included in the smart grid management context, as they provide information about electricity flow measurements and energy prices to end-consumers (Simões et al., 2012).

A smart meter system has several control devices, sensors to identify parameters and devices used to transfer data and command signals. Smart meters applied into distribution grids will play a relevant role in monitoring the load energy usage characteristics and performance on the grid. The energy consumption data collected on a regular basis allows utility companies to efficiently manage electricity demand and to advise consumers to efficiently use their appliances (Krishnamurti et al., 2012; Depuru et al., 2011).

The communication technologies employed in smart meters have to be cost efficient and must provide simultaneously a good transmission range, enhanced signal-security characteristics and improved bandwidth and power quality (Depuru et al., 2011).

There are basically two information infrastructure types needed for information flow in a smart grid system. The first flow is from electrical appliances and sensors to smart meters and the second is between smart meters and utilities’ data centers. It is considered that first data flow can be accomplished resorting to power line or wireless communications such as ZigBee, 6LowPAN, Z-wave, among others (Güngör et al., 2011). The second information data flow can be accomplished resorting to cellular technologies or Internet.

In this paper, emphasis is given to the smart technology which promotes the interface between the Portuguese power grid and Portuguese consumers of the InovGrid Project located in the city of Évora.

InovGrid is an innovator project which is based on a transformation process towards a new technical platform for power grid control and management. At a technical level this project relies on third generation technologies to merge both communication and power grid networks.

The InovGrid reference technical architecture is based on a hierarchical structure, which performs simultaneously and separately technical and commercial management. The referred hierarchical structure has three levels: prosumer level, Medium–Low voltage (MV/LV) transformation level and data control and management level (Dias, 2010).

In prosumer level, energy boxes (EB) are implemented. The EB are smart meters that provide real consumption values as well as perform in-home energy management. In MV/LV transformation level, distribution transformer controllers (DTC) are implemented. DTCs allow load monitoring and power quality analysis. They manage the EBs, control the transformation station and control the public street lights. Finally, the data control and management level assembles the commercial information and performs the grid management.

This paper focuses on the prosumer level, as it is found to contribute clear and directly to consumers’ economical savings, thus developing the consumers’ awareness of the efficient use of electricity. It develops the integration of two types of Smart Meters (SM): (i) consumer owned SM and (ii) distributor owned SM, in a SCADA system (Supervisory Control And Data Acquisition) that supervises a network of Programmable Logic Controllers (PLC) in order to optimize the electricity consumption. The SCADA system/PLC network integrates different types of information coming from the several technologies present in modern buildings—BAS (Building Automation Systems).

The developed supervisory model integrates a SCADA system (SIEMENS, 2008) connected to the MATLAB Software (The MathWorks, 2008) in order to implement advanced controllers. The communication channel selected for data transfer between SCADA and Matlab was the OPC protocol (Object Linking and Embedding – OLE – for Process Control) <http://www.opcfoundation.org>.

2. Developed strategy

SCADA systems fit very well with hierarchical control (Silva et al., 2007; Figueiredo and Martins, 2010; Figueiredo and Sá da Costa, 2008). The present work follows the advanced control structure composed by two inter-related levels: the *Operational level* (SCADA system) and the *Interactive level* that optimize the preferences of the building users in relation to control references (Figueiredo and Sá da Costa, 2012). Fig. 1 shows the information flux defined in this strategy.

At the *Operational level* the operations are performed by distributed PLCs. The communication flow between the SCADA system and the distributed PLCs is performed on an Ethernet bus. This main communication network allows also the use of other common networks widely used in lower operational levels of BAS (Neumann, 2007), namely: ModBus <http://www.modbus.org/>, BacNet <http://www.bacnet.org/> and LonWorks <http://www.echelon.com/lonworks>. The integration of these lower level communication structures in the developed strategy follows a vertical integrated approach with the use of routers, as it was previously illustrated in Fig. 1.

The two types of smart meters here studied characterize the 2 common standards in the smart consumer environment (consumer owned SM and distributor owned SM). The consumer owned SM runs over a wireless platform – ZigBee protocol and the distributor owned SM uses the wired environment – ModBus protocol.

The concept here developed for building automation allows multi-users to interact with the building control unit, which has an intelligent controller with time-varying references that accommodates advanced strategies of control.

2.1. Consumer owned smart meters

The consumer owned SM are simple devices that are mainly composed of a sensor unit and a mobile display, and run usually over a wireless network, thus suitable for domestic purposes. The main purpose of these devices is to supply simple data to support the consuming pattern of consumers.

In this paper a typical SM is developed with double interface for mobile displays and SCADA systems. It uses the ZigBee protocol which is suitable for small distances, typical for domestic environments. The used hardware is based on Arduino platform <http://www.arduino.cc/en/main/software>.

2.2. Distributor owned smart meters

The distributor owned SM are protected devices with closed communication protocols that are mainly composed by a sensor unit that counts the consumed electricity and informs remotely the local distributor. Its main purpose is to inform the electricity local distributor of the consumption of its clients providing a significant reduction on operational costs, mainly in the personal that performs the readings of the counters. In addition these data provide valuable information to the distributor concerning the consumer patterns, the optimization of the electricity selling prices, the management of the electric grid and the consuming trends.

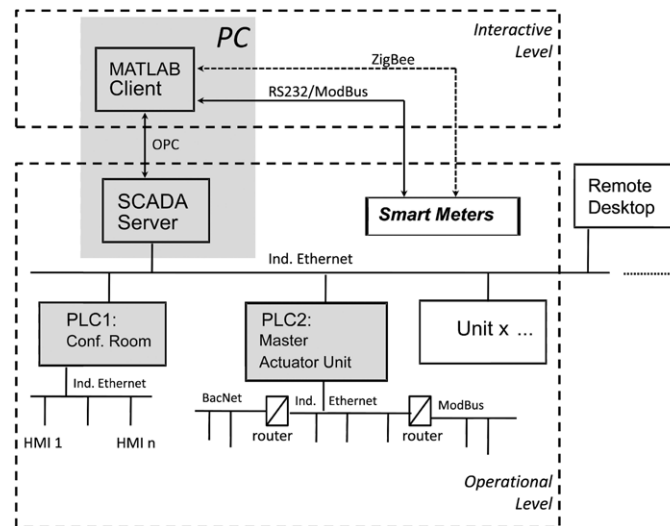

Fig. 1. Two-level supervisory control architecture.

This type of SM is now beginning to appear in specific environments selected by the electricity national distributors, in order to gain experience with the new hardware and software, allowing the correction of technical problems before its deployment in large scale consumer areas. In Portugal, the EDP distributor selected the city of Evora, with ca. 50,000 inhabitants to install these SM. This pilot, named Evora InovGrid, was completely implemented in 2010 (EDP Distribuicao, 2011). These installed SM can be connected to specific displays, also supplied by the distributor, under the payment of a monthly fee.

2.3. Supervisory control strategy

The presented strategy follows the advanced control structure composed by two inter-related levels: the *Operational level* (SCADA system) and the *Interactive level* that optimize the preferences of the building users in relation to control references (Figueiredo and Sá da Costa, 2012).

The *Operational-level* controller developed in this paper is commonly known as a hierarchical cascade controller which integrates a first control loop (inner loop) managed by local PLCs and a second control loop (outer loop) controlled by a SCADA system. Fig. 2 shows the developed *Operational Level*–SCADA supervisory control.

The input functions of the SCADA supervisory loop are mentioned as comfort laws ($F_1(t)$, ..., $F_j(t)$). These comfort laws must observe criteria of human health, system security and energy efficiency and are supplied by the 2nd level control structure—*Interactive level* (Fig. 1). Observing Fig. 1 it can be seen that the *Operational Level* (SCADA supervisory control) receives the main references (comfort laws) from the *Interactive Level*, which develops these comfort laws considering the inhabitants' preferences and the measured variables (e.g. temperature, luminosity, electricity consumption supplied by the smart meters) according to a developed optimization criterion, which defines the input references to the Master Actuator System (MAS). This criterion optimizes the inhabitants' preferences constrained by the available resources. On the other hand, the *Operational Level* supplies all the necessary data (inputs/outputs) to the *Interactive Level*, through the SCADA platform (Fig. 1).

In the developed *Operational Level* a network of distributed PLCs manages a set of distributed sensors and actuators (temperature, luminosity, HVAC, etc.) and all this distributed information is supplied to the SCADA system.

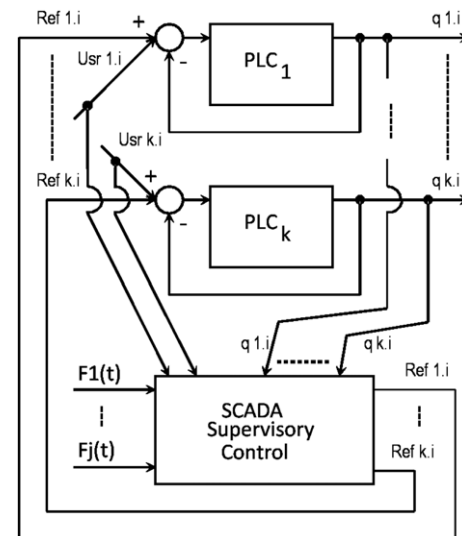

Fig. 2. Operational level controller.

3. System development

In this section the main focus is on the development of the interface for the smart meters to integrate the energy management system. A quick summary of the energy management system with a Model-based Predictive Controller (MPC) (Maciejowski, 2002) is here presented. A detailed explanation of the design of this high performance controller can be found in a previous work from the authors (Figueiredo and Sá da Costa, 2012).

3.1. Development of the interactive level controller

In this section it is summarized the development of a model for an huge area room, with distributed operator interfaces that receive the input preferences from the room users, related to the control variables. The huge-area room is here named as Conference Room. This Conference Room is connected to a Master Actuator System (MAS) that receives the commands from the SCADA platform, in order to control the room temperature, subjected to the overall restrictions of energy consumption minimization. The MAS commands the HVAC actuators. This controller, named as interactive level controller, has the possibility to receive different

set-points directly from the end-users and runs on the MATLAB platform, directly connected to the SCADA system, through the OPC communication, as it was previously referred.

The selected controller topology was the Model-based Predictive Controller (MPC) (Maciejowski, 2002). Applications of MPC to systems other than process control problems have begun to emerge over the last two decades. Predictive controllers applied to Building Automation can be found in recent literature (Chen, 2001; Yang et al., 2005; Siroky et al., 2011; Pouliezios et al., 2009).

Considering a general MIMO system (multiple input, multiple output), with n_u inputs and n_y outputs, it can be described in the state-space formulation, as:

$$x^{k+1} = A \cdot x^k + B_u \cdot u^k + B_v \cdot v^k + B_d \cdot d^k \quad (1)$$

$$y_m^k = C_m \cdot x^k + C_{vm} \cdot v^k + D_{dm} \cdot d^k \quad (2)$$

$$y_u^k = C_u \cdot x^k + D_{vu} \cdot v^k + D_{du} \cdot d^k + D_{uu} \cdot u^k \quad (3)$$

where:

u = controllable input;

v = measured perturbations vector;

d = non-measured perturbations vector;

y_m = measured output vector;

y_u = non-measured output vector;

k = sample time.

Referring now the specific problem of temperature controlling in buildings, one developed a mathematical model, adjusted to each building floor (each floor has its own linear model). This mathematical model was derived from the simple SISO model of a thermal system with a thermal source, a thermal capacitance and a thermal resistance:

$$\dot{T}(t) = \frac{1}{C} \left[qi(t) - \frac{1}{R} (T(t) - T_e(t)) \right] \quad (4)$$

where:

T = room temperature;

C = room thermal capacitance

(mainly dependent on room geometry and air pressure);

R = room thermal resistance

(mainly dependent on wall properties);

T_e = external temperature;

q_i = heat flow (dependent on Sun received radiation, presence of machinery and people, AC devices, etc.).

Expanding this model for a complete building floor, with several rooms, with specific characteristics ($T_i, C_i, R_i, q_i, T_{ei}$), one obtained the state-space model:

$$\begin{Bmatrix} \dot{T}_1 \\ \vdots \\ \dot{T}_i \\ \vdots \\ \dot{T}_n \end{Bmatrix} = \begin{bmatrix} -1/C_1 R_1 & 0 & \cdots & 0 & 0 \\ \vdots & \vdots & \vdots & \vdots & \vdots \\ 0 & \cdots & -1/C_i R_i & \cdots & 0 \\ \vdots & \vdots & \vdots & \vdots & \vdots \\ 0 & 0 & \cdots & 0 & -1/C_n R_n \end{bmatrix} \begin{Bmatrix} T_1 \\ \vdots \\ T_i \\ \vdots \\ T_n \end{Bmatrix}$$

$$+ \begin{bmatrix} -1/C_1 \\ \vdots \\ -1/C_i \\ \vdots \\ -1/C_n \end{bmatrix} \begin{Bmatrix} q_{AC1} \\ \vdots \\ q_{ACi} \\ \vdots \\ q_{ACn} \end{Bmatrix} + \begin{bmatrix} -1/C_1 R_1 \\ \vdots \\ -1/C_i R_i \\ \vdots \\ -1/C_n R_n \end{bmatrix} \begin{Bmatrix} T_{e1} \\ \vdots \\ T_{ei} \\ \vdots \\ T_{en} \end{Bmatrix}$$

$$+ \begin{bmatrix} -1/C_1 \\ \vdots \\ -1/C_i \\ \vdots \\ -1/C_n \end{bmatrix} \begin{Bmatrix} q_{d1} \\ \vdots \\ q_{di} \\ \vdots \\ q_{dn} \end{Bmatrix} \quad (5)$$

$$\begin{Bmatrix} y_1 \\ \vdots \\ y_i \\ \vdots \\ y_n \end{Bmatrix} = \begin{bmatrix} 1 & 0 & \cdots & 0 & 0 \\ \vdots & \vdots & \vdots & \vdots & \vdots \\ 0 & \cdots & 1 & \cdots & 0 \\ \vdots & \vdots & \vdots & \vdots & \vdots \\ 0 & 0 & \cdots & 0 & 1 \end{bmatrix} \begin{Bmatrix} T_1 \\ \vdots \\ T_i \\ \vdots \\ T_n \end{Bmatrix} \quad (6)$$

where:

q_{ACi} = controllable input—AC devices in room i (u_i);

T_{ei} = measured perturbations—Exterior Temperature room i (v_i);

q_{di} = non-measured perturbations—Heat flow from sunlight, machinery, people, open windows, etc. (d_i);

y_i = measured output vector—Temperature room i .

Implicit to any predictive control algorithm it is the optimization of a cost function. In this paper the selected cost function, J , has the following form:

$$J = \left(\begin{bmatrix} y(1) \\ \vdots \\ y(1) \end{bmatrix} - \begin{bmatrix} r(1) \\ \vdots \\ r(H_p) \end{bmatrix} \right)^T \cdot W_y^2 \cdot \left(\begin{bmatrix} y(1) \\ \vdots \\ y(1) \end{bmatrix} - \begin{bmatrix} r(1) \\ \vdots \\ r(H_p) \end{bmatrix} \right) + \begin{bmatrix} \Delta u(0) \\ \vdots \\ \Delta u(H_p - 1) \end{bmatrix}^T \cdot W_{\Delta u}^2 \cdot \begin{bmatrix} \Delta u(0) \\ \vdots \\ \Delta u(H_p - 1) \end{bmatrix} + \left(\begin{bmatrix} u(0) \\ \vdots \\ u(H_p - 1) \end{bmatrix} - \begin{bmatrix} u_{target}(0) \\ \vdots \\ u_{target}(H_p - 1) \end{bmatrix} \right)^T \cdot W_u^2 \cdot \left(\begin{bmatrix} u(0) \\ \vdots \\ u(H_p - 1) \end{bmatrix} - \begin{bmatrix} u_{target}(0) \\ \vdots \\ u_{target}(H_p - 1) \end{bmatrix} \right) + \rho_\varepsilon \cdot \varepsilon^2 \quad (7)$$

where the first term refers to the tracking error, the second term refers to the energetic cost of the control action and the last term charges the deviations of the control action related to the desired value, u_{target} . W_u, W_y and $W_{\Delta u}$ are factors to weigh the variables. Finally ε and its weight, ρ_ε , are relaxation factors.

Depending on the values selected for the weighting factors, W_u, W_y and $W_{\Delta u}$, different objectives can be obtained. In this case one selected similar weighting factors to all level outputs as these variables are equally important. In relation to the input variable weights, it was considered the same criteria.

The resolution of the optimization problem (7) used the Active Sets method from the MATLAB MPC-Toolbox (Bemporad et al., 2005).

The performance of this predictive controller is compared with a standard PI-controller (see Section 4.2) whose parameters were derived according to the following described method.

Considering the controllable input q_{ACi} responding as a PI-controller, it can be characterized as:

$$q_{ACi}(t) = \left(k_{1i} + \int k_{2i} dt \right) (T_i - T_{target}). \quad (8)$$

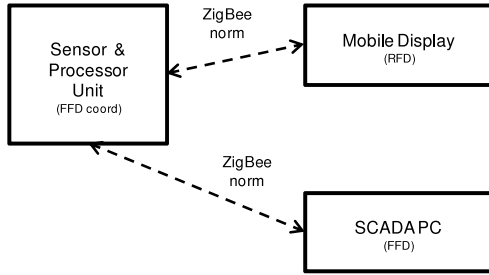

Fig. 3. Consumer owned SM: Developed topology.

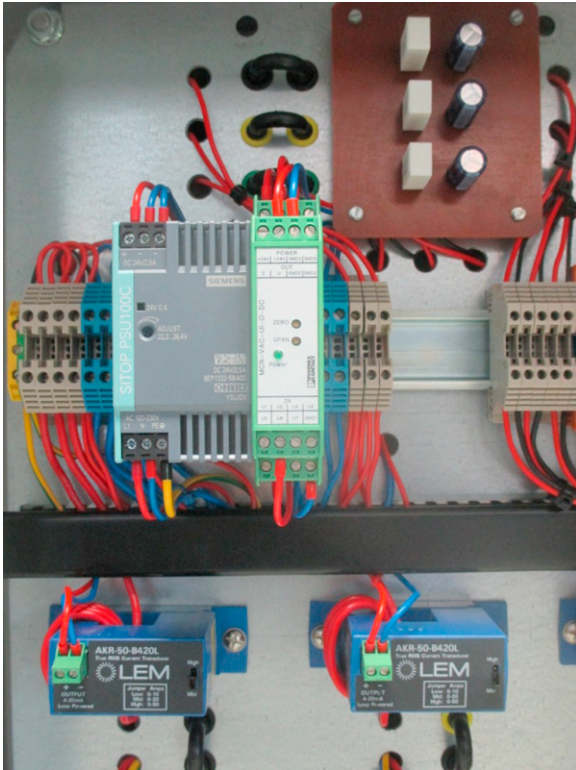

Fig. 4. Consumer owned SM: Sensor Unit connected to the house's main electrical board.

With this assumption, Eq. (4), particularized for each room, becomes:

$$\dot{T}_i(t) = \frac{1}{C_i} \left[q_{di}(t) + \left(k_{1i} + \int k_{2i} dt \right) (T_i - T_{T \text{ arg et}}) - \frac{1}{R_i} (T_i(t) - T_{ei}(t)) \right]. \quad (9)$$

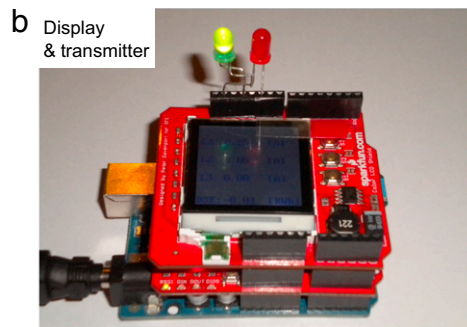
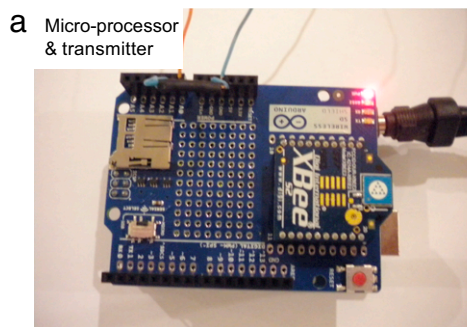

Fig. 5. Consumer owned SM: (a) Micro-processor of the Sensor Unit with the transmitter device; (b) Mobile Display mounted on an Arduino platform with ZigBee network.



Fig. 6. Consumer owned SM: Centralized Unit–SCADA system with wireless receptor.

Finally the PI parameters (k_{1i} , k_{2i}) were calculated through the minimization of the functional J_{PI} (Eq. (10)) which assures the system stability.

$$J_{PI} = \sum_{j=1}^n \begin{cases} 1/\text{Re}(\lambda_j)^2; & \text{Re}(\lambda_j) \leq -1 \\ \text{Re}(\lambda_j) + 2; & \text{Re}(\lambda_j) > -1 \end{cases} \quad (10)$$

where n is the system order and λ_j are the eigenvalues of the state space matrix.

3.2. Consumer owned smart meters (SM)

The consumer owned SM was completely newly developed and it consists of 3 main sub-systems: (i) Sensor and Processor Unit; (ii) Mobile Display; (iii) Centralized Unit (SCADA system). Fig. 3 shows the developed topology for this SM.

The sensor unit is actually composed of a set of sensors, a micro-processor and a wireless network. The used sensors are voltage and current sensors, both delivering analogue output signals between 0 and 10 V. The sensor unit is physically connected to the main electrical panel of the consumer's house (Fig. 4). This sensor unit is wired to the micro-processor of an Arduino board with a wireless transmitter (Fig. 5(a)). Finally, two wireless receivers are connected to the mobile display (Fig. 5(b)) and to the centralized SCADA PC server (Fig. 6). The mobile display needs also to be connected to an Arduino board in order to get autonomous signal processing capabilities. The used wireless network was the ZigBee norm, according to IEEE 802.15.4.

The Arduino is an open source platform developed in Italy in 2005. The used software to program the Arduino CPU is

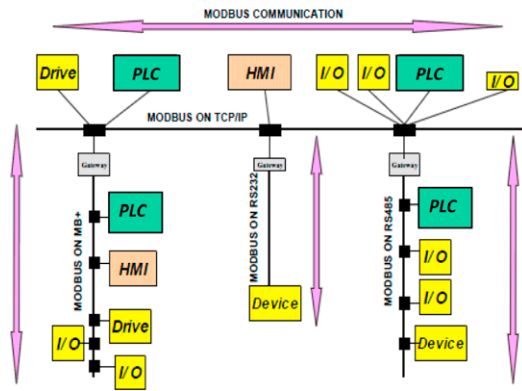

Fig. 7. ModBus communication.

freely available at <http://www.arduino.cc/en/main/software>. All the necessary software drivers are also freely available at <http://www.arduino.cc/en/main/software>.

The used wireless module was the XBee which was first developed by Digi International Inc., according to the ZigBee network protocol, following IEEE 802.15.4 peer to peer. The used software for network configuration was the X-CTU <http://www.digi.com/support>.

The norm IEEE 802.15.4 defines two types of participants in the network: FFD—Full Functioning Device and RFD—Reduced Functioning Device.

The developed ZigBee network followed the common standard, with 3 different components: (i) one Coordinator which establishes the network (FFD); (ii) 0 to n Routers that allow the enlargement of the spatial network coverage (FFD); (iii) 0 to n End Devices that can send and receive data, but are not able to enlarge the spatial network coverage (RFD).

The ZigBee norm allows two types of topologies: (i) Peer-to-Peer and (ii) star. The Peer-to-Peer topology can be subdivided into Mesh and Cluster Tree. In this work the selected topology was the Peer-to-Peer Mesh because it has the advantage of flexibility and dynamic regeneration whenever a network node loses functionality. However, this redundancy has a cost on transmission speed as the new automatic established path does not minimize the distance transmitter/receiver.

In the developed network, our three components were defined as: Sensor & Processor unit (Coordinator); centralized unit (Router) and mobile display (End Device), as it was previously illustrated in Fig. 3.

The used parameters were:

ID-PAN ID – 0000
Baud Rate – 9600.

3.3. Distributor owned smart meters (SM)

In this paper it is studied the smart meter named EB BTN (Energy Box—Normal Low Voltage) for domestic use, from the Portuguese electricity distributor EDP.

The EB BTN supplies the consumer the following information, sequentially, through its two-line alphanumeric display: date and time; contracted power; contracted tariff; consumed power in each contracted category; real time values (Active Power—Voltage—Current; power factor; network frequency).

The EB BTN communicates with the consumer by either display or ModBus protocol. In this paper the ModBus communication was used to establish the interface with the SCADA system through the MATLAB application. The ModBus communication has two main possibilities: (i) ModBus TCP and (ii) ModBus RTU/ASCII. The distributor's device EB BTN allowed only the RTU interface. This

ModBus interface runs on the RS485 configuration. This configuration enables the connection among distributed devices (ca. 1200 m). (Fig. 7.)

A converter RS232-RS485 was used to connect the PC to the EB BTN, with the Peer to Peer configuration.

The studied EB BTN follows the ModBus serial line and has three function codes available: (i) read registries; (ii) write registries; (iii) read inputs of the load diagram.

The ModBus format for the data transfer is assured by 256 bytes and it is composed of 4 fields: Address field; Function Code; Data; CRC (Cyclic Redundancy Check) <http://www.modbus.org/specs/>.

4. System implementation and experiments

A Supervisory Control and Data Acquisition (SCADA) System is used as an application development tool that enables system integrators to create sophisticated supervisory and control applications for a wide variety of technological domains, mainly in the industry field. The main feature of a SCADA system is its ability to communicate with control equipment in the field, through the PLC network. As the equipment is monitored and data is recorded, a SCADA application responds according to system logic requirements or operator requests.

4.1. Software and hardware requirements

The SCADA system was developed over the platform Siemens Simatic WinCC (SIEMENS, 2008). Siemens Simatic Manager STEP 7 (SIEMENS, 2001) was used to program the PLCs and to configure the communications: (i) SCADA system—PLC Master (Ethernet) and (ii) within the PLC network (Profibus). MATLAB (The MathWorks, 2008) was used to compute the predictive controller actions. The Siemens Simatic Net (SIEMENS, 2006) was the selected server for the OPC service. The Siemens Simatic OPC Scout (SIEMENS, 2008) was used to configure the OPC communication protocol between the MATLAB and the WinCC SCADA.

In the performed laboratory tests, the used hardware was mainly composed by two Siemens S7-300 PLCs with respective HMI panels (Human Machine Interface) as illustrated in Fig. 8. The additional inputs from the multi-users were directly introduced on the SCADA menu.

4.2. SCADA application

In the developed control strategy, the SCADA application performs the outer loop of the Operational level and communicates with the MPC controller (Interactive level). Due to the characteristics of the developed SCADA/MATLAB platform, high complex control structures can be used to manage the overall system.

As complex controllers need mathematical operations that are not present at available SCADA systems, this strategy couples the SCADA system (SIEMENS, 2008) with the MATLAB software (The MathWorks, 2008), where complex mathematical operations are solved. The used communication channel between the SCADA (SIEMENS, 2008) and the Matlab software (The MathWorks, 2008) is the OPC protocol (Object Linking and Embedding – OLE – for Process Control) <http://www.opcfoundation.org>. This protocol is based on standard specifications developed in 1996 by a task force from industrial automation (Santos et al., 2005). This standard specifies the communication of real-time data among several control devices from different manufacturers. This protocol provides the exchange of data between two independent software programs (Server and Client) running simultaneous at the implemented platform. In this paper the MATLAB software initiates the communication, as it is the Client and

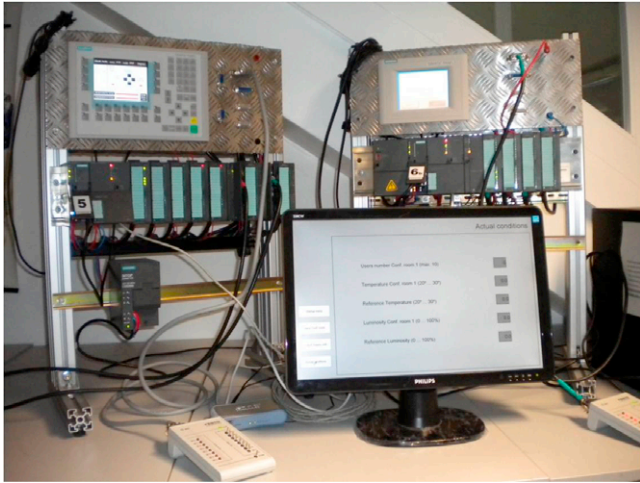

Fig. 8. Experimental PLC network.

the SCADA software responds to Client’s requests (Server attributions) (<http://www.opcfoundation.org> and Santos et al., 2005). Basically, once defined the OPC Server, one has to define the set of tags to be communicated between the two software partners (MATLAB and WinCC SCADA).

As an example of the MPC controller implementation, Fig. 9 shows the developed model to build up a consistent reference data to the MPC controller through the input of multiple-user set-points.

Both SM (user owned and distributor owned) integrates the SCADA–PLC system at the SCADA interface, as it was shown in 1. The MATLAB software is used to build up an application to receive the data from the SM. The OPC protocol supplies this data to the SCADA–PLC system. This strategy SCADA–PLC system allows the bi-directionality of the information flux: downwards to the actuators and upwards to the control algorithm where the future control actions are calculated.

Several SCADA menus were built for the developed Energy Management System. The main characteristic of a SCADA Menu is to be simple, explicit and quick on transmitting the information to the system operator. Two types of Menus were here developed: Interactive displays with summarized values and (ii) time dependent graphics for variable monitoring.

In Fig. 10 it is illustrated the interactive Menu built for the developed 3-Phase consumer owned SM.

Finally as a quantitative example of the performance of the system as a rooms’ temperature controller, with time-dependent references, Fig. 11 shows the comparative results between the MPC and the traditional PI controller (see Section 3.1).

5. Conclusions

This paper develops an energy management system with integration of smart meters for electricity consumers in a smart grid context. The integration of two types of smart meters (SM) are developed: (i) consumer owned SM and (ii) distributor owned SM. The SM are connected to a SCADA system (Supervisory Control And Data Acquisition) that supervises a network of Programmable Logic

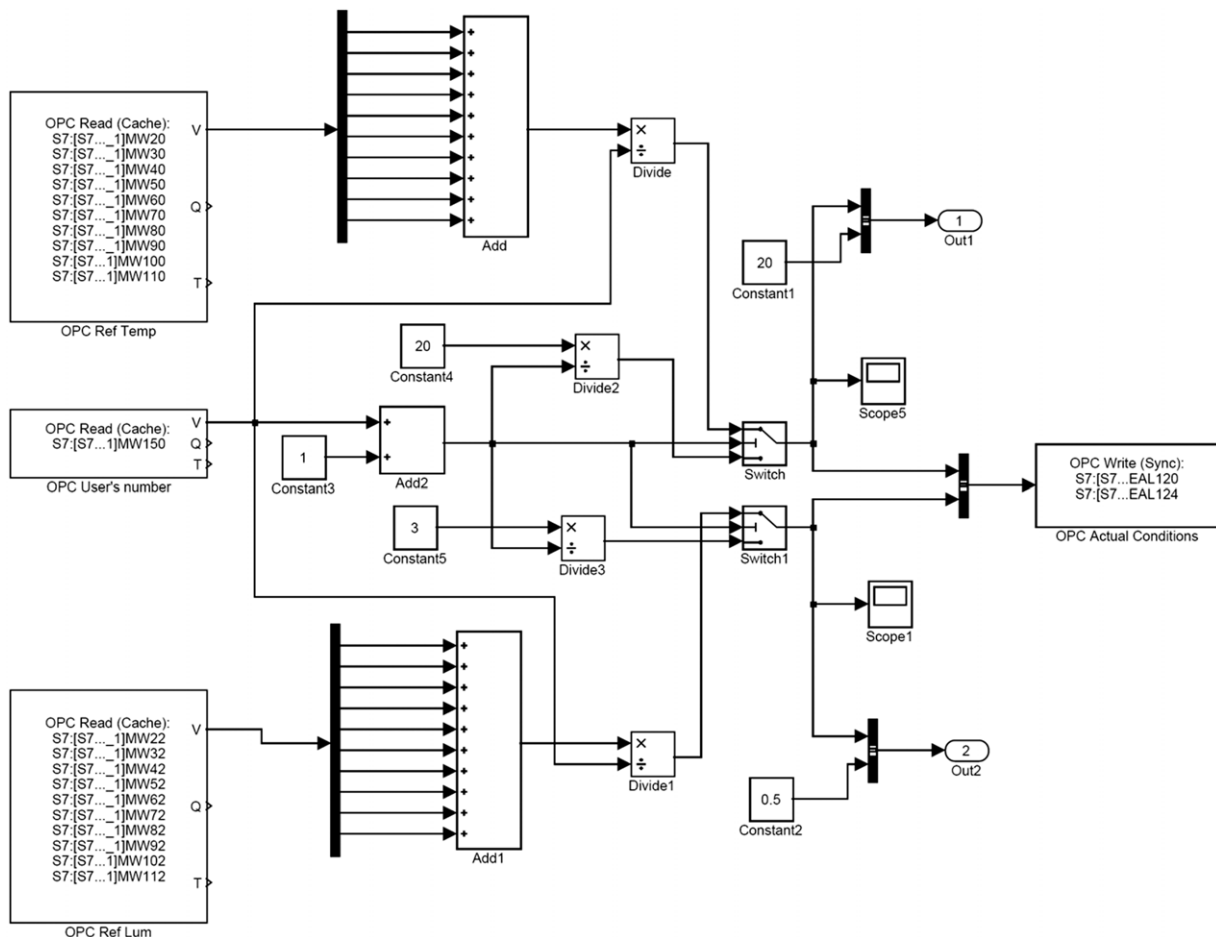

Fig. 9. MATLAB model for reference block.

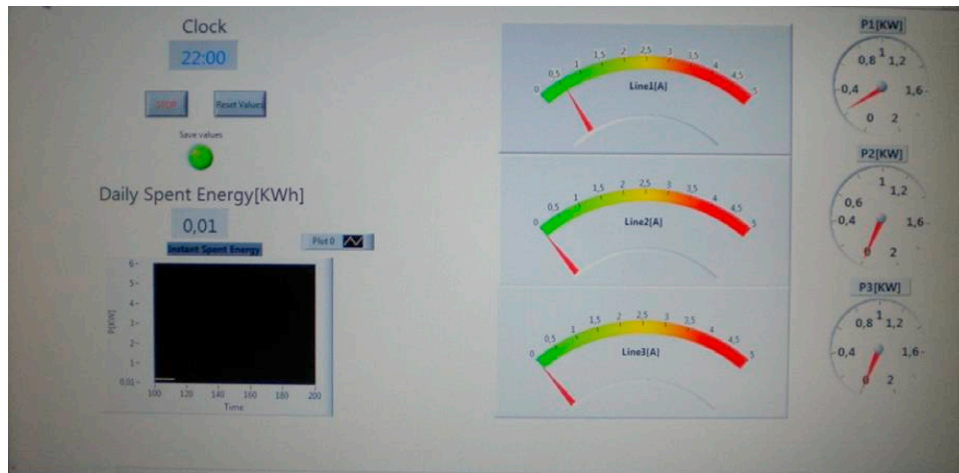

Fig. 10. SCADA interactive menu—data from the 3Phase developed consumer owned SM.

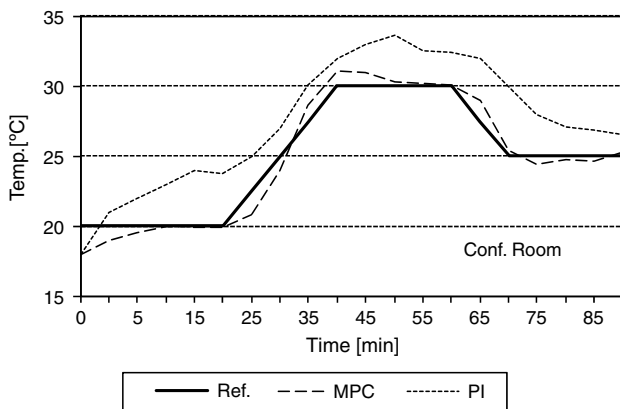

Fig. 11. Experimental data for temperature control—Conference room.

Controllers (PLC). The SCADA system/PLC network integrate different types of information coming from the several technologies present in BAS (Building Automation Systems).

The developed control strategy implements a hierarchical cascade controller where inner loops are performed by local PLCs, and the outer loop is managed by a centralized SCADA system, which interacts with the entire local PLC network.

In order to implement advanced controllers, a communication channel was developed to allow the communication between the SCADA system and the MATLAB software.

A major contribution of the present study is the development of a complete new platform connecting the SCADA supervisory system, the MATLAB software, and the two existing main topologies of electricity smart meters (distributor owned and customer owned), in order to provide the usual SCADA systems with the ability to handle complex control algorithms for consumer energy management systems. The developed Internet-based control platform allows also the use of other common networks widely used in lower operational levels of BAS.

Acknowledgments

This work was supported by Fundacao Ciencia e Tecnologia, through IDMEC, under LAETA. The studied EB BTN was gently donated by EDP Distribuicao and CONTAR.

References

Bemporad, A., Morari, M., Ricker, N., 2005. *Model Predictive Control Toolbox for Use with MATLAB*, second ed. The Mathworks.

- Chen, T., 2001. Real-time predictive supervisory operation of building thermal systems with thermal mass. *Energy Build.* 33 (2), 141–150.
- Depuru, S.S.R., Wang, R., Devabhaktuni, V., 2011. Smart meters for power grid: Challenges, issues, advantages and status. *Renew. Sustain. Energy Rev.* 15, 2736–2742.
- Dias, A.J.F., 2010. *Telecontagem e Gestão de Energia em Casa—Conceito FunEnergy, Tese de Mestrado Integrado em Engenharia Electrotécnica e de Computadores, Faculdade de Engenharia da Universidade do Porto.* (Master thesis in portuguese).
- EDP Distribuicao. 2011. Smart Grid Pilots—What Drives Success. In: 2nd Intl. Conf. Smart Grids & Smart Cities, Lisbon, September.
- Figueiredo, J., Martins, J., 2010. Energy production system management—renewable energy power supply integration with building automation system. *Energy Convers. Manag.* 45, 1120–1126.
- Figueiredo, J., Sá da Costa, J., 2008. Operative platform applied to building automation. *Comput.-Aided Civ. Infrastruct. Eng.* 24, 26–40.
- Figueiredo, J., Sá da Costa, J., 2012. A SCADA system for energy management in intelligent buildings. *Energy Build.* 49, 85–98.
- Gangale, F., Mengolini, A., Onyeji, I., 2013. Consumer engagement: An insight from smart grid projects in Europe. *Energy Policy* 60, 621–628.
- Geelen, D., Reinders, A., Keyson, D., 2013. Empowering the end-user in smart grids: Recommendations for the design of products and services. *Energy Policy* 61, 151–161.
- Güngör, V.C., Sahin, D., Kocak, T., Ergüt, S., Buccella, C., Cecati, C., Hancke, G.P., 2011. Smart grid technologies: Communication technologies and standards. *IEEE Trans. Ind. Inform.* 7 (4), 529–539.
- Kolokotsa, D., Pouliezos, A., Stavrakakis, G., Lazos, C., 2009. Predictive control techniques for energy and indoor environmental quality management in buildings. *Build. Environ.* 44, 1850–1863.
- Krishnamurti, T., Schwartz, D., Davis, A., Fischhoff, B., Bruin, W.B., Lave, L., Wang, J., 2012. Preparing for smart grid technologies: A behavioural decision research approach to understanding consumer expectations about smart meters. *Energy Policy* 41, 790–797.
- Maciejowski, J., 2002. *Predictive Control with Constraints*, second ed. Prentice-Hall.
- Melvin, H., 2014. The role of ICT in evolving smartgrids. In: 10th International Conference on Digital Technologies. IEEE, Slovakia, pp. 235–237.
- Neumann, P., 2007. Communication on industrial automation—What is going on? *Control Eng. Pract.* 15 (11), 1332–1347.
- Santos, R., Normey-Rico, J., Gomez, A., Arconada, L., Moraga, C., 2005. OPC based distributed real time simulation of complex continuous processes. *Simul. Model. Pract. Theory* 13, 525–549.
- SIEMENS. 2001. Simatic S7-300 – Ladder Logic (LAD) for S7-300.
- SIEMENS. 2006. Communication with SIMATIC, System Manual.
- SIEMENS. 2008. Simatic WinCC V7.0.
- SIEMENS. 2008. Simatic Net OPC Scout V10.
- Silva, P., Botto, M., Figueiredo, J., Rijo, M., 2007. Model predictive control of an experimental water canal. In: IFAC/IEEE European Control Conference, ECC'07, Greece, pp. 2977–2984.
- Simões, M.G., Roche, R., Kyriakides, E., Suryanarayanan, S., Blunier, B., McBee, K.D., Nguyen, P.H., Ribeiro, P.F., Miraoui, A., 2012. A comparison of smart grid technologies and progresses in Europe and the U.S. *IEEE Trans. Ind. Appl.* 48 (5), 1154–1162.
- Siroky, J., Oldewurtel, F., Cigler, J., Privara, S., 2011. Experimental analysis of model predictive control for an energy efficient building heating system. *Appl. Energy* 88, 3079–3087. <http://dx.doi.org/10.1016/j.apenergy.2011.03.009>.
- The MathWorks, 2008. MATLAB 7.6.0.324 (R2008a), The MathWorks Inc.
- Vijayapriya, T., Kothari, D.P., 2011. Smart Grid: An Overview. *Smart Grid Renew. Energy* 2, 305–311.
- Yang, J., Rivard, H., Zmeureanu, R., 2005. On-line building energy prediction using adaptive artificial neural networks. *Energy Build.* 37 (12), 1250–1259.