

Jarsulic, Marc

Working Paper

Profits, Cycles and Chaos

Working Paper, No. 20

Provided in Cooperation with:

Levy Economics Institute of Bard College

Suggested Citation: Jarsulic, Marc (1989) : Profits, Cycles and Chaos, Working Paper, No. 20, Levy Economics Institute of Bard College, Annandale-on-Hudson, NY

This Version is available at:

<https://hdl.handle.net/10419/186711>

Standard-Nutzungsbedingungen:

Die Dokumente auf EconStor dürfen zu eigenen wissenschaftlichen Zwecken und zum Privatgebrauch gespeichert und kopiert werden.

Sie dürfen die Dokumente nicht für öffentliche oder kommerzielle Zwecke vervielfältigen, öffentlich ausstellen, öffentlich zugänglich machen, vertreiben oder anderweitig nutzen.

Sofern die Verfasser die Dokumente unter Open-Content-Lizenzen (insbesondere CC-Lizenzen) zur Verfügung gestellt haben sollten, gelten abweichend von diesen Nutzungsbedingungen die in der dort genannten Lizenz gewährten Nutzungsrechte.

Terms of use:

Documents in EconStor may be saved and copied for your personal and scholarly purposes.

You are not to copy documents for public or commercial purposes, to exhibit the documents publicly, to make them publicly available on the internet, or to distribute or otherwise use the documents in public.

If the documents have been made available under an Open Content Licence (especially Creative Commons Licences), you may exercise further usage rights as specified in the indicated licence.

Profits, Cycles and Chaos

by

Marc Jarsulic*

Working Paper No. 20

April 1989

**Submitted to
The Jerome Levy Economics Institute
Bard College**

***Department of Economics, University of Notre Dame, Notre Dame, IN and The Jerome Levy Economics Institute, Bard College, Annandale-On-Hudson, NY.**

1. INTRODUCTION

Some time ago Goodwin (1967) offered an elegant and influential model to represent part of Marx's thinking on business cycles. In that model he was able to show how the interaction of the reserve army of labor and the process of capital accumulation could produce self-sustaining oscillatory behavior. Increases in the real wage cause decreases in the rate of growth of the capital stock, since all wages are consumed and all profits invested. The declining rate of accumulation in turn causes a decline in the employment rate, which eventually causes the wage rate to decline. The eventual expansion in the growth rate of the capital stock begins the process over again. This behavior was described by fitting a model of a one good economy into the Lotka-Volterra equations, the solution to which is well known. While it has proved extremely fruitful, this model also has some well known limitations. It is first of all a center, so that no limit cycle produced by the model is stable. Second, it takes a rather asocial approach to the creation of the labor force, assuming that it is governed exclusively by an exogenously given rate of population growth. Also, the model assumes that all technical change occurs at a constant, autonomously given rate, and allows for no induced components.

In what follows some minor alterations to the Goodwin model

are shown to introduce interesting new behavior. By making technical change depend on economic and social phenomena, and by assuming that the labor force grows at least in part in response to social phenomena, it is easy to show that the model will now generate stable limit cycles. When the model is changed still further, to allow for systematic periodic influences -- such as those an economy might experience as a result of seasonal changes in labor force participation or productivity -- somewhat more dramatic dynamic behavior follows. Under certain conditions, the model ceases to be periodic and instead becomes chaotic. The resulting behavior is more business-cycle-like because of it is irregular. But at the same time the existence chaos implies difficulties for empirical "deseasonalization" of data.

The possibility of chaos introduces some questions for the study of business cycles. One is whether it is possible to discriminate between economic phenomena which are induced by chaos-generating non-linearities, and those which are introduced by stochastic shocks to some underlying non-linear system. The model is used to illustrate this problem and show how an existing technique for testing for chaos -- the calculation of Lyapunov exponents -- is able to handle it.

2. A MODIFIED GOODWIN CYCLE MODEL

The Goodwin growth cycle model is easy to represent. Given the definitions

x = the employment rate

y = labor's share in net output

a = the output/capital ratio, assumed fixed

b = the rate of growth of the labor force

c = the rate of growth of output per unit of labor

e = a threshold value of the employment rate

the model is given by

$$\dot{x}/x = a - ay - b - c$$

$$\dot{y}/y = x - e \tag{1}$$

Let us begin to develop the model by first altering the representation of labor force growth. One of the outstanding characteristics of a capitalist economy, as Marx recognized, is its ability to change social reality if the need for labor becomes strong enough. It can do this by defining groups of workers in or out of the labor force as convenient (e.g. the recognition of the productive abilities of women during wartime, and the denial when war ends); increasing immigration or emigration by changing laws governing the treatment of aliens; and by destroying non-capitalist economic formations over time. This point of view is part of contemporary neo-marxian analysis as well. Marglin

(1984, pp. 108-9) notes that:

The labor force available to the capitalist sector expands (or contracts) according to demand. In the neo-Marxian view, a buoyant capitalism will meet its labor requirements much as the countries of northern and southern Europe did in the quarter century of expansion that followed World War II, first by drawing on the labor resources of family agriculture and other noncapitalist modes of production, then by drawing on the labor resources of an ever-widening geographical periphery that ultimately included the entire Mediterranean basin and beyond.

By the same token, a stagnant capitalism will simply fail to attract labor. In the extreme case of declining demand for labor, the labor force available to the capitalist sector will decline absolutely. In the place of the overt unemployment that characterizes stagnation in the neo-Keynesian view, neo-Marxian unemployment is characteristically "disguised unemployment"...

Now the implication of this point of view is that the dynamics of labor supply are complex and historically specific. Hence any attempt to model them must be a bit inadequate. However, we can go a little way toward including them in the Goodwin model by replacing the constant b with the term

$$b_0 + b_1x^2 \tag{2}$$

This slight alteration allows increasing employment rates to have a negative impact on their own growth. It can be taken to stand for the self-correcting behavior of capitalist economies in labor supply.

Next we want to say something about technical change. Since this is a subject about which knowledge is slim, it is hard to do

so with much confidence. However, the empirical work of Gordon et al. (1985) suggests that wage rates and employment rates have, respectively, positive and negative effects on productivity growth. This is a consequence of their effect on the cost of job loss. The higher the real wage, the more is lost when one is out of work. And the greater the employment rate, the higher the probability that a new job can be found. Hence we will replace the constant c with the term

$$c_0 + c_1Y - c_2x \quad (3)$$

The alterations suggested in (2) and (3) can be combined to alter the expression for \dot{x}/x . These changes, together with a specification for the wage determination equation which is slightly faster moving than the one in (1), allows us to rewrite the system (1) as

$$\dot{x}/x = a - by + cx - dx^2 \quad (4)$$

$$\dot{y}/y = (1. - e/x)m \quad m > 0$$

The values of the coefficients of this system can be interpreted in obvious ways.

The dynamics of system (4) can be determined by well known methods. The isoclines of the system are displayed in figure 1. There are three fixed points in the figure, and the one of interest to us is labeled A. The behavior of the system around point A can be determined in part by looking at the Jacobian

$$J = \begin{bmatrix} \partial \dot{x} / \partial x & \partial \dot{x} / \partial y \\ \partial \dot{y} / \partial x & \partial \dot{y} / \partial y \end{bmatrix} \quad (5)$$

The stability of A will depend on the value of $\text{Tr}(J)$ evaluated at A. Some calculation will show that given the parameters in (4), the value of $\text{Tr}(J)$ will pass from positive to negative as the vertical isocline is moved from the origin past the maximum value of the $\dot{x} = 0$ isocline. That is, the system changes from unstable to stable as the $\dot{y} = 0$ isocline is moved from left to right. Now by appealing to the Hopf bifurcation theorem (Guckenheimer and Holmes, 1983, pp. 151-2), we know that this change in stability implies the existence of a limit cycle about point A. The amplitude of this cycle will increase as the value of $\text{Tr}(J)$ increases. What we do not know from the evaluation of (5) is the nature of the limit cycle. It could be everywhere attractive (supercritical) or attractive from only one side (subcritical). However, by evaluating an index (Liu et al., 1986) of the form

$$\begin{aligned} I = & (v^2 C)^{-1} [(B(F_{xxx} + G_{xxy}) + 2D(F_{xxy} + G_{xyy}) + C(F_{xyy} + G_{yyy}))v^2 \\ & + (DF_{xx} + CF_{xy})(BF_{xx} + 2DF_{xy} + CF_{yy}) \\ & - (DG_{yy} + BG_{xy})(BG_{xx} + 2DG_{xy} + CG_{yy}) \\ & - B^2 F_{xx} G_{xx} - DB(F_{xy} G_{xx} + F_{xx} G_{xy}) \\ & + C^2 F_{yy} G_{yy} + DC(F_{xy} G_{yy} + F_{yy} G_{xy})], \end{aligned} \quad (6)$$

where $F(x, y) = \dot{x}$, $G(x, y) = \dot{y}$, $C = G_x$, $D = F_x$, $B = -F_y$, and $v^2 =$

$(BC-D)^2$, it is possible to tell what is going on. When $I > 0$ the limit cycle is subcritical, and when $I < 0$ it is supercritical. Some calculation will show that $I < 0$ when $\text{Tr}(J) > 0$, so the limit cycle is supercritical. The behavior of this system can of course be simulated. A time series produced by such a simulation is displayed in figure 2.

3. PERIODIC TERMS AND DYNAMIC BEHAVIOR

While it is instructive to know that the alterations in the Goodwin model generate limit cycle behavior, we can get somewhat more from it by acknowledging the existence of periodic forces which act on the state variables of the system. For example, there are undoubtedly many seasonalities in labor force participation rates -- students move in and out of the labor force with vacations; people seek temporary work over certain holidays -- and in productivity growth -- weather changes and regular vacation periods no doubt affect it. The interactions of these periodic forces can generate complex effects.¹ We will summarize their impact by including a term in $\cos(\omega t)$ among the existing constants in the first equation in (4). For purposes of exposition we do so by redefining the constant a as

$$a_0 - a_1 \cos(\omega t) \tag{7}$$

noting that this is not intended to represent a fluctuating capital output ratio. The effects of this change in (4) can be seen through simulation. The outcomes are dependent on the values of the three constants in (7). For the values $a_0=.35$, $a_1=.07$, $w=.4$, with all other coefficients the same as those which obtain for the simulation displayed in figure 2, the time series produced are still periodic, as can be seen from figure 3. The behavior is now more complex than it was, since the system is now three dimensional. The three dimensional plot of the system in figure 4 shows that it exhibits motion on a torus. This is not the end of the possible behavior for this system, however. It is well known (Thompson and Stewart, 1985, pp. 84-107) that the addition of forcing terms to dynamical systems can sometimes induce chaotic behavior. Indeed, Inoue and Kamifukumoto (1984) have shown that a differently modified version of the Lotka-Volterra equations can produce chaos with forcing if the frequency of the forcing term has particular values. In their model, the unforced system has an angular frequency of 2.3. By adding the forcing term and simulating while varying the angular frequency of forcing over the interval $[2.5, 4.0]$, they were able to locate subintervals where chaos appears. Although system (4) is different from that used by Inoue and Kamifukumoto, some of the dynamic properties appear similar. Notably, for some of the values of $r \in [2.5, 4.0]$ which generate chaos in their system, values of w satisfying $w/14 = r/2.3$ will generate apparently aperiodic behavior in (4). However, the intervals containing the parameter values in which chaos exists are narrower than in their system.²

When, for example, the value of w is increased to .594, behavior of the system appears to become aperiodic. A time series for this altered system is displayed in figure 5. The three dimensional portrait of the system is given in figure 6. It is significantly distorted from the nicely behaved torus, and appears folded and stretched as the Lorenz and Rössler attractors do. It certainly looks "chaotic."

Appearance can be deceiving, of course, and we need to do more to establish the chaotic nature of this attractor. Short of a proof, which does not offer itself at the moment, there are some techniques which can be used. One is to construct a Poincaré section for the attractor, and to look for the folding behavior in the section. A Poincaré section for system, constructed by holding the value of expression (7) constant at .4, and then recording the first intersection with that plane on each orbit of the attractor, is shown in figure 7. It has a folded structure, and as such is consistent with chaos. The Poincaré map can also be used to construct a circle map. The the angles each point on he map, relative to an appropriately selected center, are calculated. Each angle $z(t)$ is plotted against the previously calculated angle $z(t-1)$. This plot is the circle map. For a non-chaotic system, the plots suggest monotonicity and continuity. For chaotic systems, continuity and monotonicity break down. The circle map for the system with $w = .594$ is given in figure 8. The map has the broken appearance exhibited by maps of chaotic systems. This may be taken as another indication that we have chaos.

As another test of the nature of this attractor, we will

estimate the largest Lyapunov exponent using one of the time series generated by the simulation. Lyapunov exponents can be considered generalized eigenvalues. When looking at a difficult-to-solve system of ordinary differential equations at a fixed point, the local dynamics can be derived by linearizing the system and then calculating the eigenvalues of the Jacobian. (This is what was behind the consideration of (5).) This procedure is generalized over an entire attractor to produce time-varying quantities which describe the dynamic behavior of state variables. To illustrate, consider a three dimensional system of ordinary differential equations

$$\dot{X}(t) = (\dot{x}, \dot{y}, \dot{z}) \quad (8)$$

and denote its flow, i.e. the solution of $\dot{X}(t)$ from an initial vector (x_i, y_i, z_i) , as $f_i(t)$. Now the difference in flows for any two points can be written as

$$\delta f(t) = f_1(t) - f_2(t) \quad (9)$$

where δ is the first difference operator. To actually know the value of (9) requires solving (8), but by linearization we have

$$\dot{\delta f}(t) = [dX(t)/df(t)](\delta f(0)) \quad (10)$$

where $dX(t)/df(t)$ is evaluated with changing local coordinates. The Lyapunov exponents are calculated by manipulating $dX(t)/df(t)$

in ways analogous to those used to extract eigenvalues from a constant matrix. However, since the elements of $X(t)$ vary with time, it is necessary to look for an average value over the attractor.³ For a chaotic attractor, the largest exponent will be positive. This makes sense if nearby points are to diverge -- if there is to be sensitive dependence on initial conditions.

Now to obtain an estimate of the largest exponent for an attractor, one can use a technique developed by Wolf (1985). It requires taking a time series for one of the variables and performing a Takens reconstruction of the the attractor. The largest Lyapunov exponent is then calculated by following nearby trajectories around the attractor. For system (4) with forcing, the exponent, estimated from a time series of 20,000 observations on the wage share is .03. This is consistent with chaos. This value, it should be noted, is dependent on the way one chooses to follow the trajectories around the attractor.⁴

4. DISTINGUISHING CHAOTIC FROM STOCHASTIC SYSTEMS

Since any actual economic data may contain stochastic elements, it is useful to ask whether the techniques used to test for chaos can distinguish between a deterministic system subject to shocks and a chaotic one. To look at this issue in the the context of the present model, the system was simulated with no forcing term, but with all state variables subject to a random shock every ten iterations. The shocks were uniformly distributed, with a maximum absolute value of .07. A time series for this

system is displayed in figure 9. It looks appropriately disturbed. These data were also transformed and the Lyapunov exponent calculated. These data were analyzed in the same way as those for the chaotic attractor. The estimated Lyapunov exponent was .1672. This is not enormously encouraging. However, it has been suggested that the effects of noise can be reduced by changing the way in which trajectories are followed around the reconstructed attractor. By increasing the minimum distance between trajectories being followed from some initial point, overestimates of the exponent are less likely. The results of varying this distance are shown in figure 10. As the minimum distance (scalmin) is increased, the estimated exponent for the stochastic system falls, but not consistently. For the chaotic attractor, the exponent is sometimes reduced, but not always. Discerning something from these patterns as an empirical economist would clearly be a trying experience.

5. CONCLUSIONS

By making some relatively minor alterations to the Goodwin growth cycle model, it has been possible to extend its economic reach. The phenomenon of self-sustaining growth cycles was shown to be compatible with endogenously determined technical change and a self-correcting labor supply process. Both these modifications are part of the current neo-marxian economic analysis. After integrating these ideas into the model, its dynamic possibilities can be expanded still more by adding consideration of seasonalities. Along with stable limit cycles, such a system can

produce the irregularities of chaotic dynamics.

The time series from the chaotic version of the model look a bit more like the time series which we actually observe in a real economy. Since they are constructed by introducing interaction among periodicities, they have an interesting implication for the classic problem of "deseasonalizing" time series data. Deseasonalization is an attempt to clean up observations by identifying and removing the periodic blips that clutter them. However, even if the intuition of an underlying seasonality is correct, cleaning up the data may be an impossible task. This will be so if the interaction of the underlying regularities produces chaotic outcomes.

The simulations of the model are also useful in illustrating another problem for empirical economics. They show a difficulty in distinguishing between data produced by chaotic and stochastically perturbed non-linear systems. Lyapunov exponents from chaotic and stochastic versions of this model are close, even when appropriate adjustments are made in the estimating procedure. Sorting out one from the other will clearly require the use of other measurement techniques, such as the correlation integral.

REFERENCES

- Bergé, P., Pomeau, Y. and Vidal, C. 1984. Order within Chaos.
New York: J. Wiley and Sons.
- Goodwin, R. 1967. A Growth Cycle. In C. Feinstein (ed),
Socialism, Capitalism and Economic Growth. Cambridge:
Cambridge University Press.
- Gordon, D., Weisskopf, T., and Bowles, S. 1985. Hearts and
Minds. Brookings Papers, No. 1.
- Grassberger, P. and Procaccia, I. 1984. Dimensions and Entropies
of Strange Attractors from a Fluctuating Dynamics Approach.
Physica D, 13, pp. 34-54.
- Guckenheimer, J. and Holmes, P. 1983. Nonlinear Oscillations,
Dynamical Systems, and Bifurcations of Vector Fields. New
York: Springer Verlag.
- Inoue, M. and Kamifukumoto, H. 1984. Scenarios Leading To Chaos
In A Forced Lotka-Volterra Model. Progress Of Theoretical
Physics. 71: 930-37.
- Liu, W., Levin, S. and Yoh, I. 1986. Influence of Nonlinear
Incidence Rates Upon The Behavior of SIRS Epidemiological

- Models. Journal Of Mathematical Biology. 23: 187-204.
- Marglin, S. 1984. Growth, Distribution and Prices. Cambridge, MA: Harvard University Press.
- Thompson, J. and Stewart, H. 1986. Nonlinear Dynamics and Chaos. New York: J. Wiley and Sons.
- Wolf, A. 1986 Quantifying Chaos with Lyapunov Exponents. In: A.V. Holden (ed), Chaos. Manchester: Manchester University Press, pp. 273-90.

FOOTNOTES

1. If all periodic effects were seasonal, i.e. had periods less than or equal to a year, and their effects were additive, then the period of a composite forcing term would also be seasonal. However, non-linear interactions are possible among seasonalities - e.g. workers can take winter vacations, making firms hire replacements, and thus multiply the negative effects of winter weather on productivity. Hence we might have terms like $\sin(w_i t)\sin(w_k t) = 1/2[\cos(w_i - w_k)t - \cos(w_i + w_k)t]$ which can allow for non-annual periods. Also, not all periodic effects need be annual. There may be, for example, longer weather cycles.

2. The Inoue-Kamifukumoto model is

$$\dot{x} = (a - b \cos(wt))x - cy - dx^3$$

$$\dot{y} = y(cx - a)$$

Without forcing, $b=0$.

3. Lyapunov exponents are discussed in Grassberger and Procaccia (1984) and in Bergé et al (1984, pp.279-88). The discussion in the text follows Bergé et al. They use the following special case to illustrate the idea of Lyapunov exponents. Suppose that $dX(t)/df(t) = \begin{bmatrix} A & B & C \end{bmatrix}$, where $A = A(f(t))$. Then we have from $\dot{\delta f}(t) = dX(t)/df(t) \delta f(0)$ that $\dot{\delta x} = A \delta x(0)$. This can be integrated to obtain $\delta x(t) = \delta x(0) \exp \int_0^t A dt$. This in turn can be transformed to give $1/t (\ln(\delta x(t)/\delta x(0))) = 1/t \int_0^t A dt$. Since it can be shown

that \bar{A} , the average value of A is given by $\bar{A} = \lim_{t \rightarrow \infty} 1/t \int_0^t A dt$, then $\lim_{t \rightarrow \infty} \ln \delta x(t) / \delta x(0)$ is equal to \bar{A} . A general version of this result is the basis for estimates of the largest Lyapunov exponent.

4. To estimate the largest Lyapunov exponent, the Wolf algorithm proceeds as follows: From a single time series, make a Takens embedding of the form $z_i = (x(t_i), x(t_i+q), \dots, x(t_i+(d-1)q))$, where d is the embedding dimension, q is a time lag. Plot the z_i in d -space. Then pick a reference trajectory on the constructed attractor. Pick another trajectory within a specified distance of the reference, i.e. at a distance greater than $scalmin$, but less than $scalmax$. Follow this test trajectory and reference trajectory for a sufficient distance. Calculate $L_i = \log_2(D_r/D_t)$, where D_r is the distance between the initial and final point on the reference trajectory, and D_t is the similar distance on the test trajectory. Then proceed along the reference trajectory and calculate L_i again. Then use the sum $\sum_i L_i / N$, where N is the number of computations, as an estimate the largest Lyapunov exponent.

In this paper, $q=1$, $d=3$, and the attractors are followed for a period of 14, which is approximately the period of the unforced version of the system.

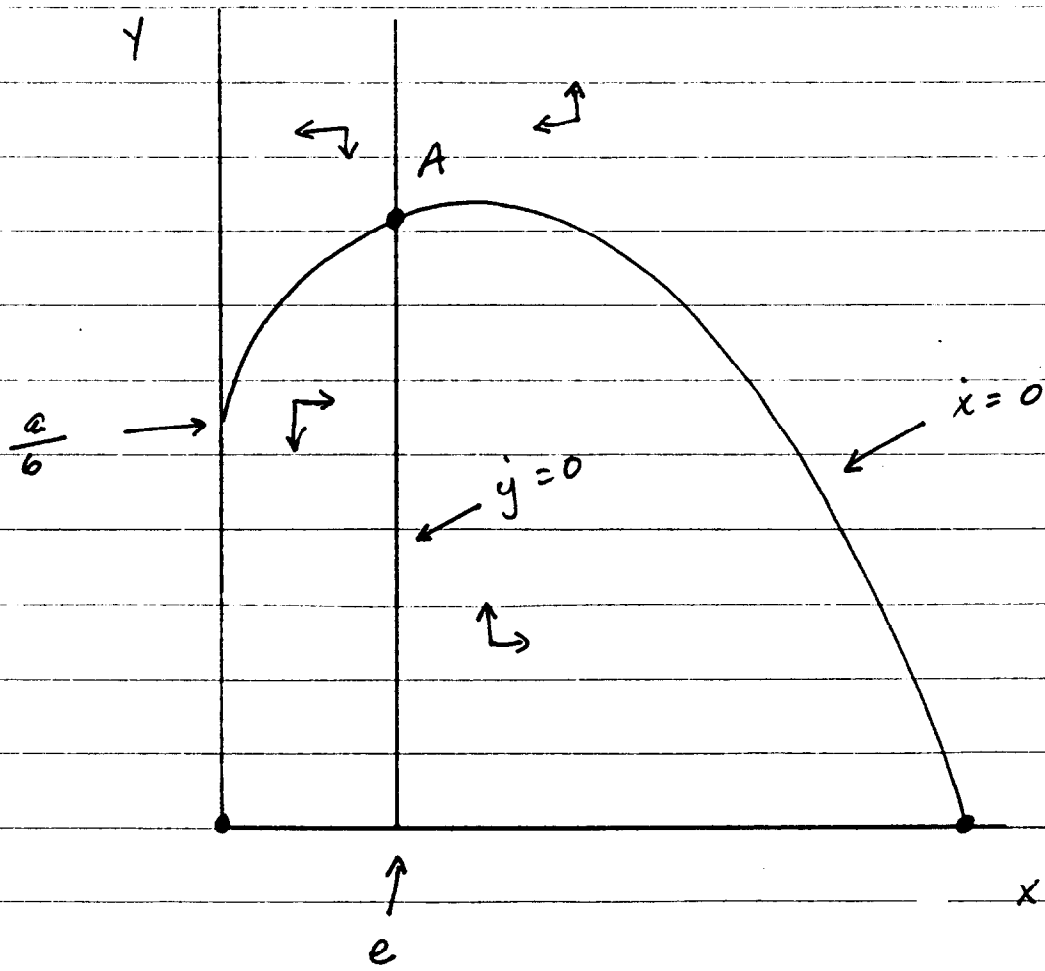
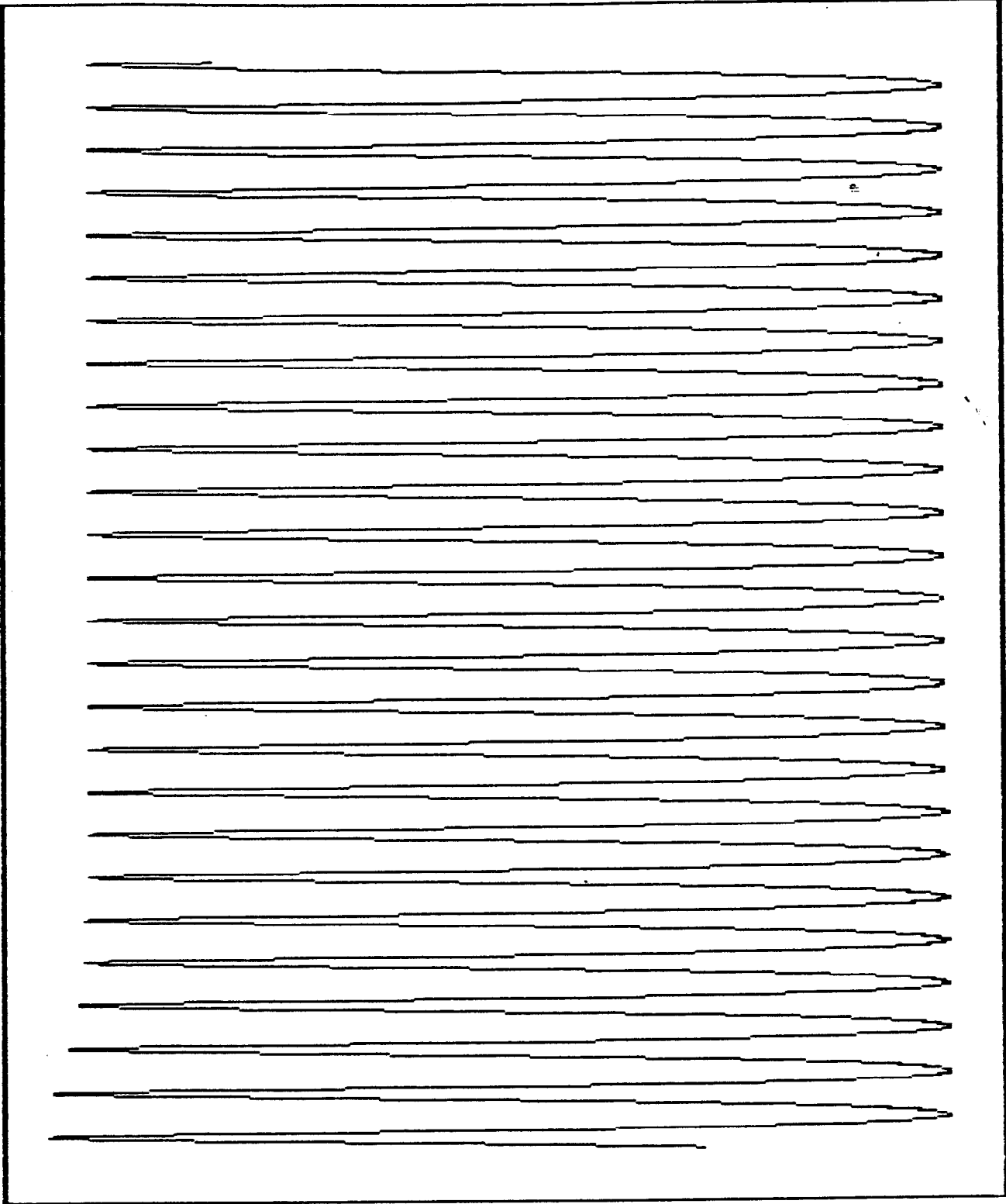

FIGURE 1

WAGE SHARE



COEFFICIENT VALUES: $a = .35$, $b = .65$,

$c = .75$, $d = 1.7$, $e = .2$, $m = .5$

TIME

FIGURE 2

WAGE SHARE

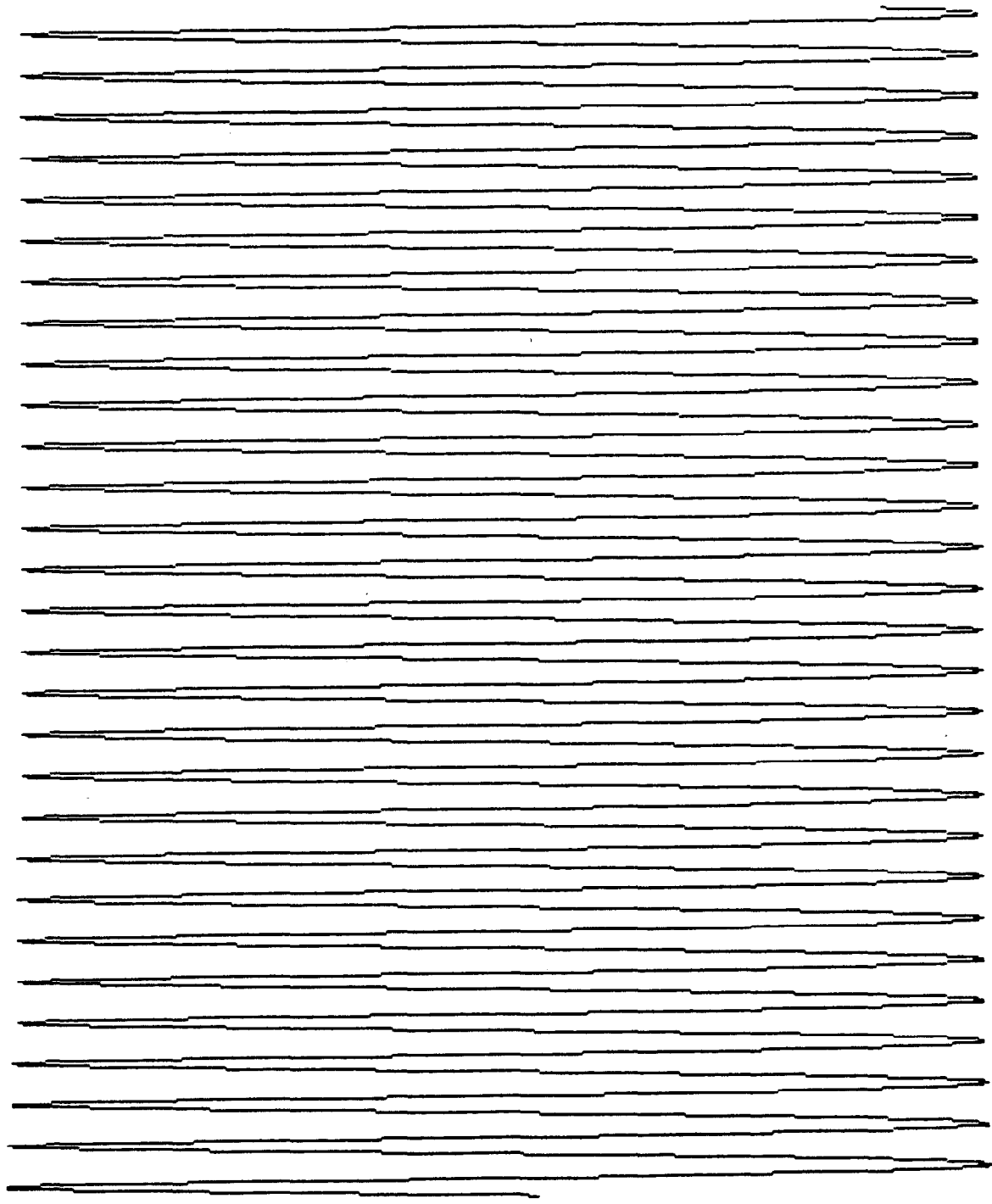

TIME

FIGURE 3

X=WAGE SHARE

Y=EMPLOYMENT RATE

$$Z = a_0 + a_1 \cos(\omega t)$$

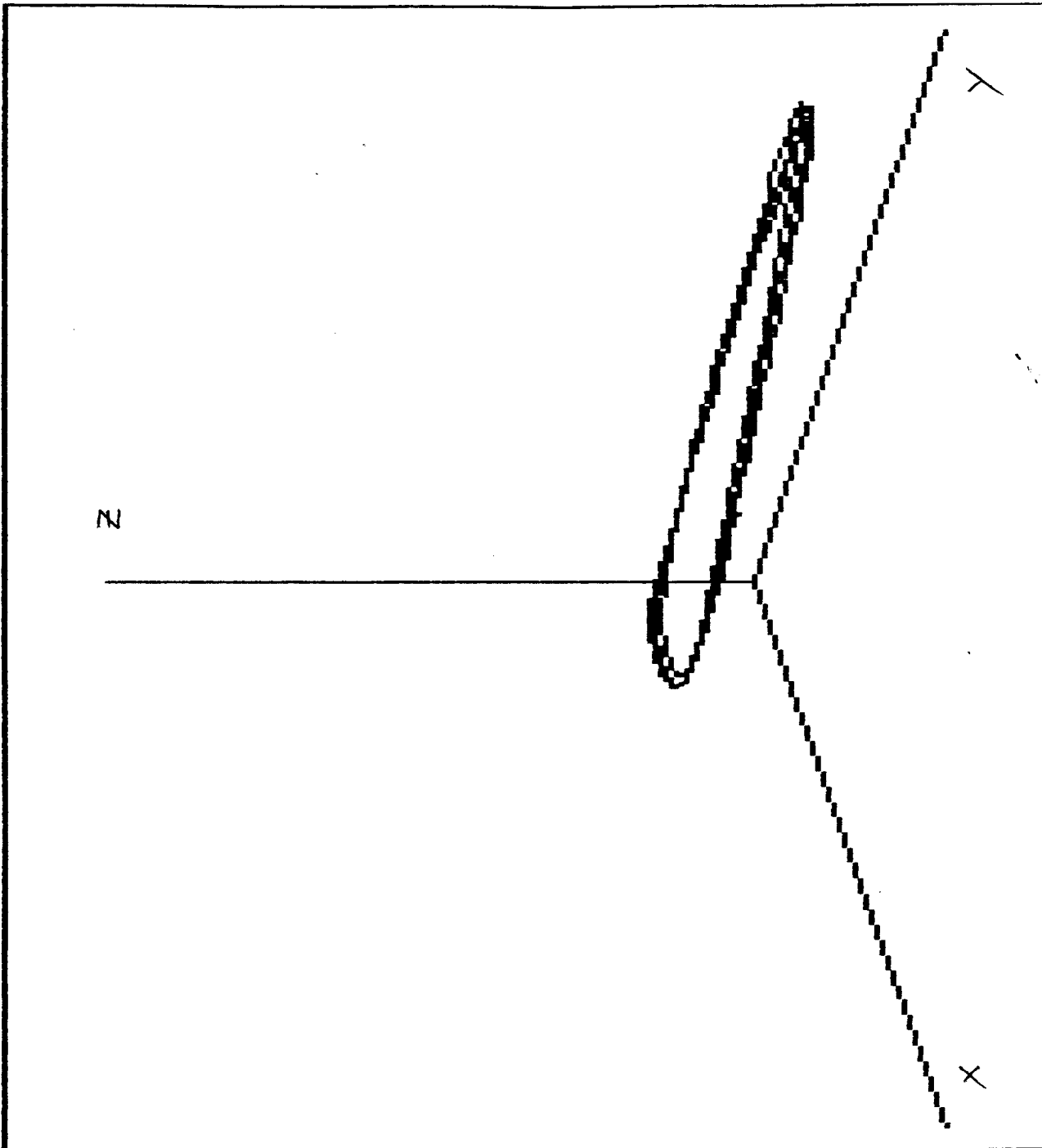
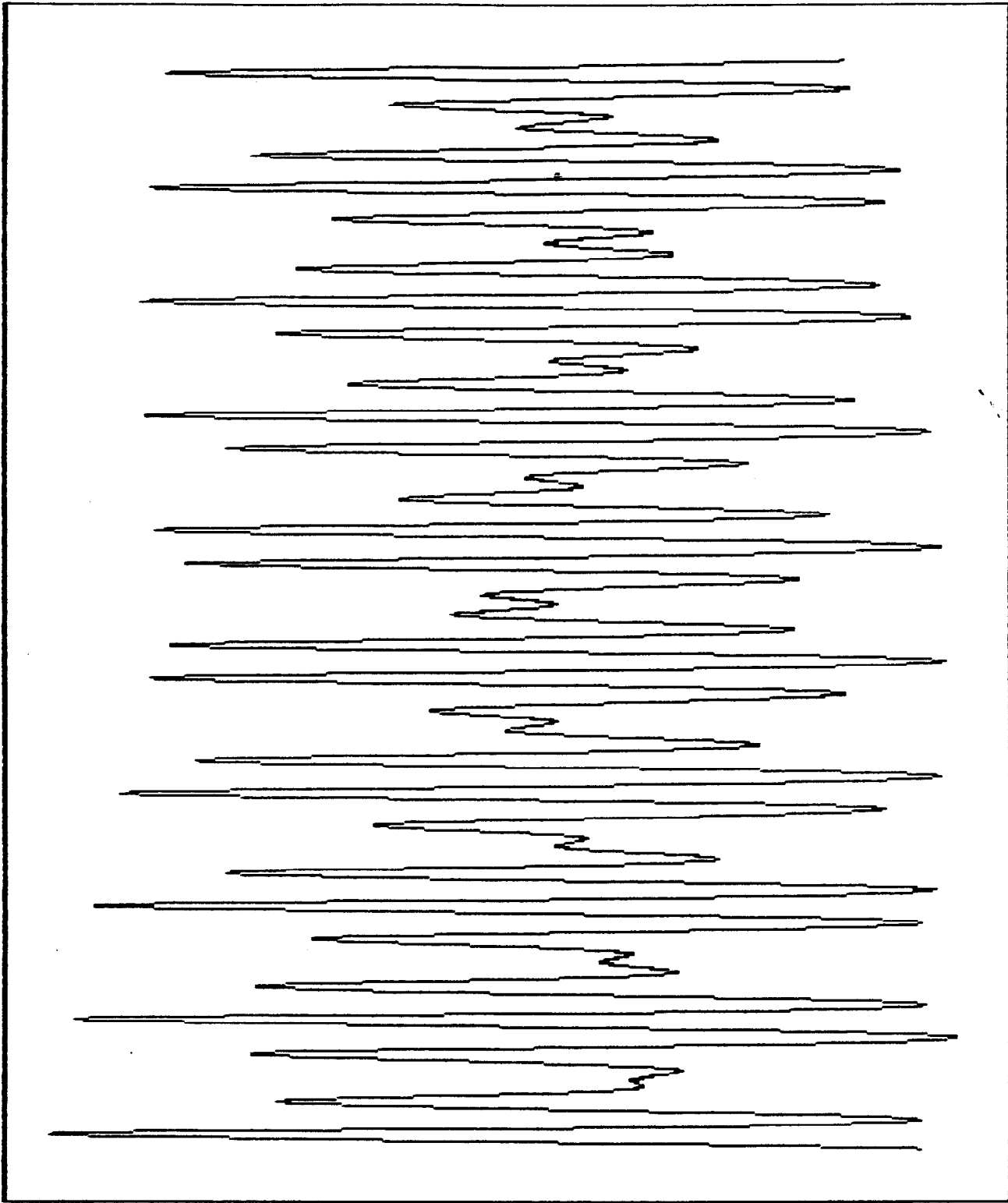

FIGURE 4

WAGE SHARE



TIME

FIGURE 5

X=WAGE SHARE

Y=EMPLOYMENT RATE

$$Z = a_0 + a_1 \cos(wt)$$

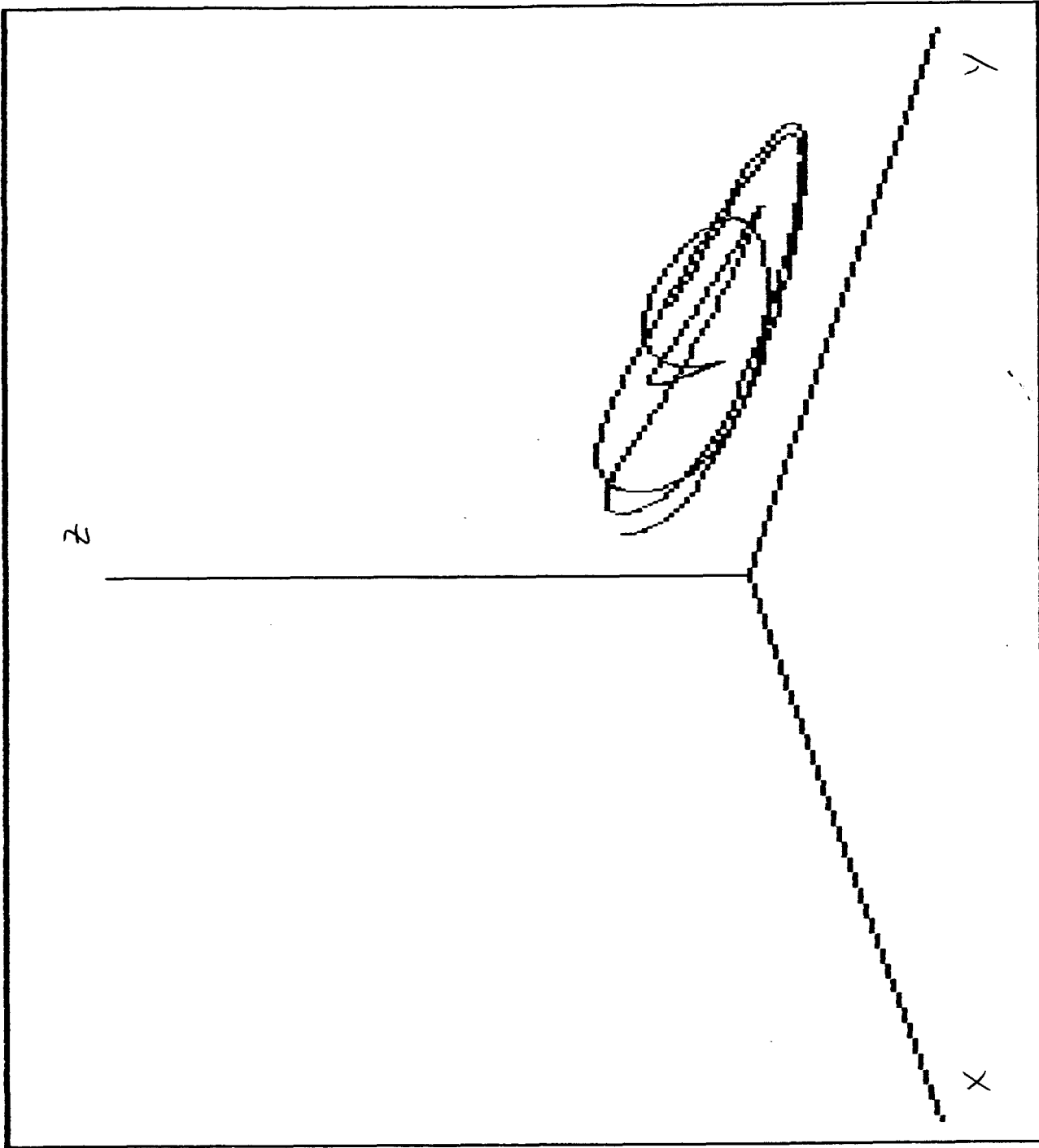
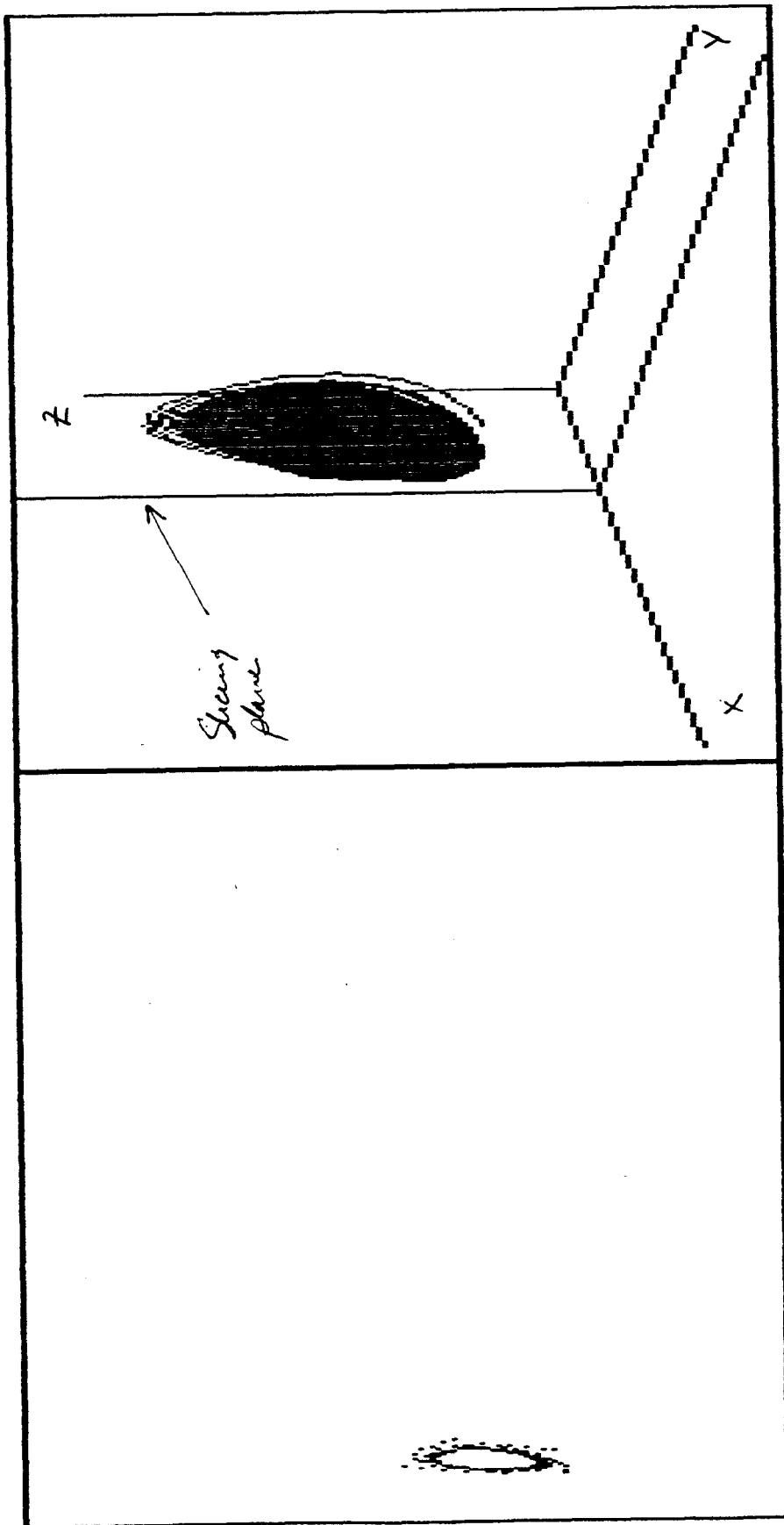

FIGURE 6



POINCARÉ SECTION

$$X = a_0 + a_1 \cos(\omega t)$$

Y = WAGE SHARE

Z = EMPLOYMENT RATE

FIGURE 7

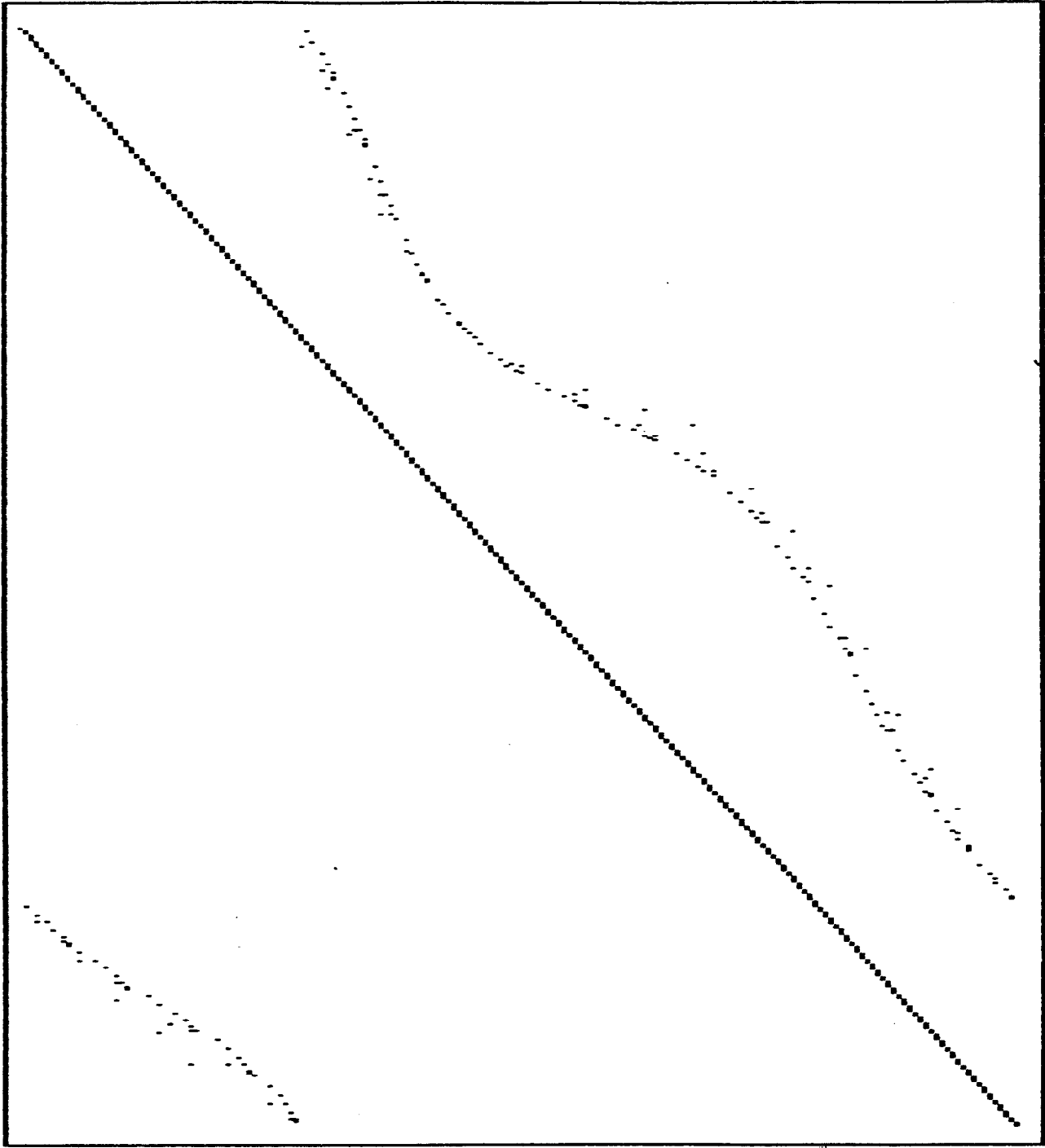

CIRCLE MAP

FIGURE 8

WAGE SHARE

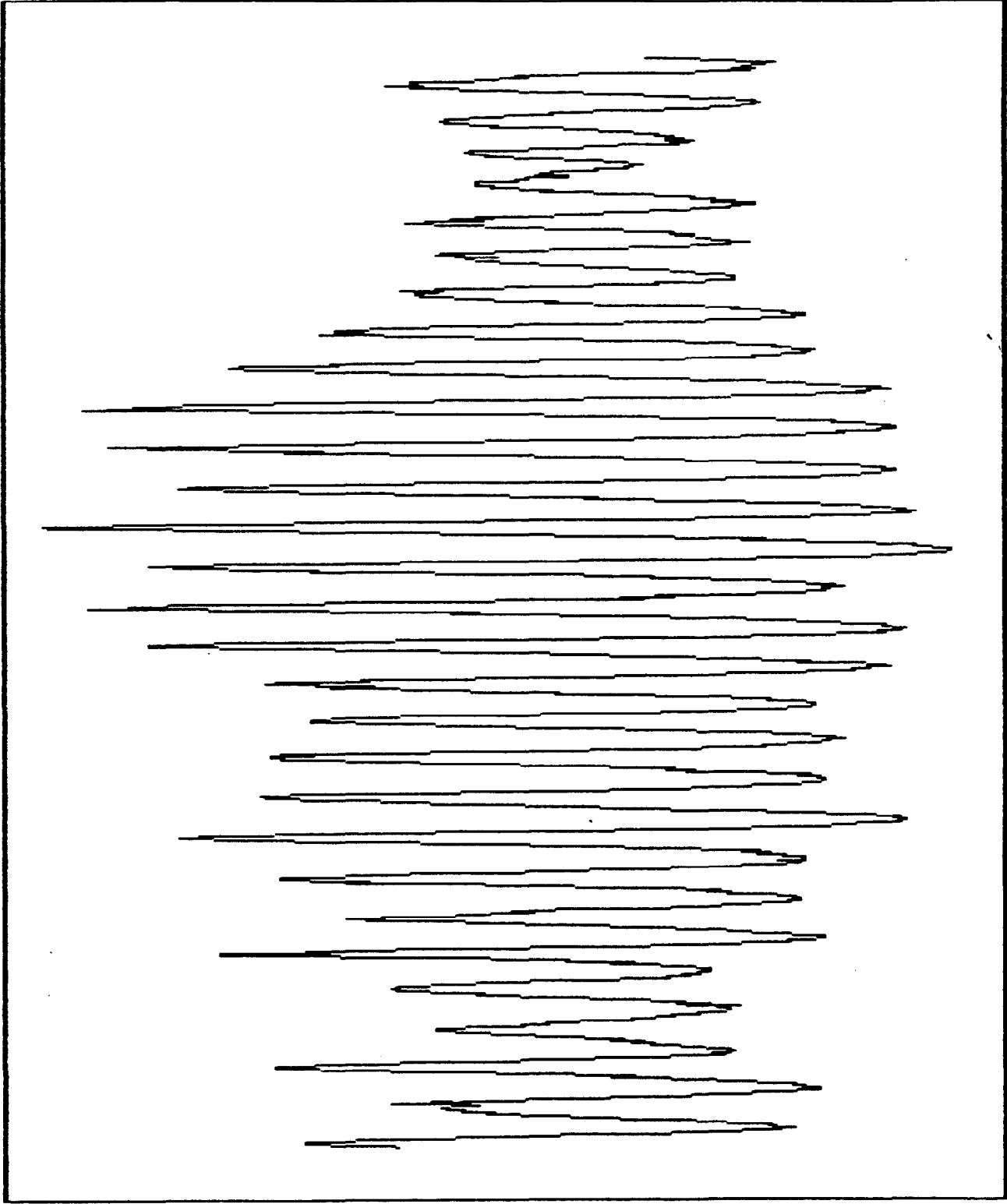

TIME

FIGURE 9

CHAOTIC SYSTEM

Scalmin, Scalmax, LE

.0001, .025, .03

.07, .095, .018

.08, .105, .03

.1, .125, .02

STOCHASTIC SYSTEM

Scalmin, Scalmax, LE

.0001, .025, .17

.07, .095, .08

.08, .105, .06

.1, .125, .07

FIGURE 10