

Ostrowska, Teresa; Krupa, Tadeusz

Article

Determinants of critical infrastructure resources

Foundations of Management

Provided in Cooperation with:

Faculty of Management, Warsaw University of Technology

Suggested Citation: Ostrowska, Teresa; Krupa, Tadeusz (2017) : Determinants of critical infrastructure resources, Foundations of Management, ISSN 2300-5661, De Gruyter, Warsaw, Vol. 9, Iss. 1, pp. 331-346,
<https://doi.org/10.1515/fman-2017-0025>

This Version is available at:

<https://hdl.handle.net/10419/184634>

Standard-Nutzungsbedingungen:

Die Dokumente auf EconStor dürfen zu eigenen wissenschaftlichen Zwecken und zum Privatgebrauch gespeichert und kopiert werden.

Sie dürfen die Dokumente nicht für öffentliche oder kommerzielle Zwecke vervielfältigen, öffentlich ausstellen, öffentlich zugänglich machen, vertreiben oder anderweitig nutzen.

Sofern die Verfasser die Dokumente unter Open-Content-Lizenzen (insbesondere CC-Lizenzen) zur Verfügung gestellt haben sollten, gelten abweichend von diesen Nutzungsbedingungen die in der dort genannten Lizenz gewährten Nutzungsrechte.

Terms of use:

Documents in EconStor may be saved and copied for your personal and scholarly purposes.

You are not to copy documents for public or commercial purposes, to exhibit the documents publicly, to make them publicly available on the internet, or to distribute or otherwise use the documents in public.

If the documents have been made available under an Open Content Licence (especially Creative Commons Licences), you may exercise further usage rights as specified in the indicated licence.



<https://creativecommons.org/licenses/by-nc-nd/4.0>

DETERMINANTS OF CRITICAL INFRASTRUCTURE RESOURCES

Teresa OSTROWSKA*, Tadeusz KRUPA**

Warsaw University of Technology, Faculty of Management, Warsaw, Poland

*e-mail: teresa.ostrowska@pw.edu.pl

**e-mail: tadeusz.krupa@pw.edu.pl

Abstract: This article is devoted to the issue of how resources are interpreted in the form of technology reactors that, as a result of unexpected circumstances, turn into pyramidal or avalanche threat dynamics. Counteracting such catastrophic, terrorist, or war situations cannot begin in the face of mass casualties or significant material losses that will require reconstruction and the work of many generations. The decisive factor is the correct long-term operation and management of the economy. The starting point of this article is the concept of resource and structural–functional relationships of resources and all their possible interpretations consistent with the functionalities they play in the human environment, human aggregates, and whole nations. The aim is to draw the reader's attention to the importance (semiotics) of qualitative specifications and dynamically changing determinants contained in the material and structural-functional properties of the resources and their channel (information) communication.

Keywords: technology reactor, resource, structural–functional properties of the resources, cluster resource model for threats, resource transformation process.

1 Introduction

The problem of structural and functional determinants of resource dynamics is being examined today in critical infrastructure (CI) research in many countries. This article¹ is devoted to a wide range of issues related to the interpretation of phenomena accompanying CI hazards in their normal operation and also in situations resulting from the various hazards of catastrophes, terrorism, or war. Hence, CI security issues are considered as determinants:

- in the theoretical reflections on the essence of the concept of the resource and its various forms of real and abstract occurrences in the disciplines of the sciences of management (Domański et al., 2014; Ficoń, 2007),
- in terms of material and structural–functional characteristics of resources (Krupa, 2014a; Krupa, 2014b),

- in a resource cluster model of threats (Krupa, Ostrowska, 2017),
- in the structure and transformation of resources in technology reactors (Ostrowska, Krupa, 2014).

The term resource is treated as a universal term, in place of which the name of the highlighted element (real or abstract) of the modeled reality is substituted. The resource can be "something" or "someone". Resources have their own structure. They can be described by a set of attributes; there are certain relationships between resources. Resource class is defined as a set that includes resources with the same sets of characteristics and their individual values for each resource belonging to the class (Krupa, 2006).

The concept of a resource in abstract interpretation is used as an invariant of any material or information realities that are subjected to transformations in other material or informational realities. Examples of abstract interpretations of resources are: model of the phenomenon, object model, and process model.

It should also be noted that the trend in resource theory has focused on the different strategic interpretation of the results for resource aspects of management (Kaleta, 2011).

¹ The material developed for the project was a highly specialized platform supporting civil emergency planning and rescue services in the public administration in Poland and in the organizational units of the national system of rescue and firefighting. Contract No DOB-BIO7/1100202015 dated 22 December 2015. The project was 100% financed by the NCBR budget. Consortium: School of Management – Warsaw University of Technology.

Within this stream, a number of detailed interpretations have been developed, which devoted, inter alia, to issues such as:

- the relationship between a resource and a positional approach to strategic management in today's businesses (Kaleta, 2011),
- resource constraints for strategic reorientation (Romanowska, 2011),
- utility and behavioral aspects of the resource-based view (RBV) model (Gospodarek, 2011),
- resource theory of the company – limitations in the study of interorganizational phenomena (Czakoń, 2011),
- systemic stimulants of strategic business renewal at the interface of resource and process language (Belz, Skalik, 2011),
- resource management approach to public organization – stakeholder perspective (Frączkiewicz-Wronka, 2011),
- assessment of the level of harmonization of the overall strategy and functional strategies in the enterprise and many other contemporary emerging concepts (Jelonek, 2011).

2 Resources and their material and structural–functional characteristics

Interpretation of CI in resource categories allows the use of a relatively simple conceptual apparatus to describe the complex issue of the specification

and identification of CI systems that are the basis for undertaking specific national security activities.

The purpose of the resource specification is to determine the means of their material and structural–functional classification. Structural–functional classification serves to describe resources oriented on homogeneous physical and structural material characteristics.

Features' material resources relate to the quantitative and qualitative characteristics of the homogeneous materials that make up the resource or resources in the community of CI. Material and qualitative characteristics of resources, such as flammability or vulnerability to radioactivity, may have important implications for the safety of the operating parameters of special equipment. The vulnerability of material resources to damage can be significantly reduced if the resources are isolated from potential hazards or the appropriate quantitative and logistical redundancy is ensured.

The structural and functional characteristics of resources refer to the (informative) resource links of objects that determine their cooperation. Among the structural features are those that determine the reliable functioning of the CI in question.

The limitation of structural features on information resource input channels requires an adequate repertoire of input channel states and acceptable mechanisms for changing these states so that trajectories of adverse changes in these states are impeded.

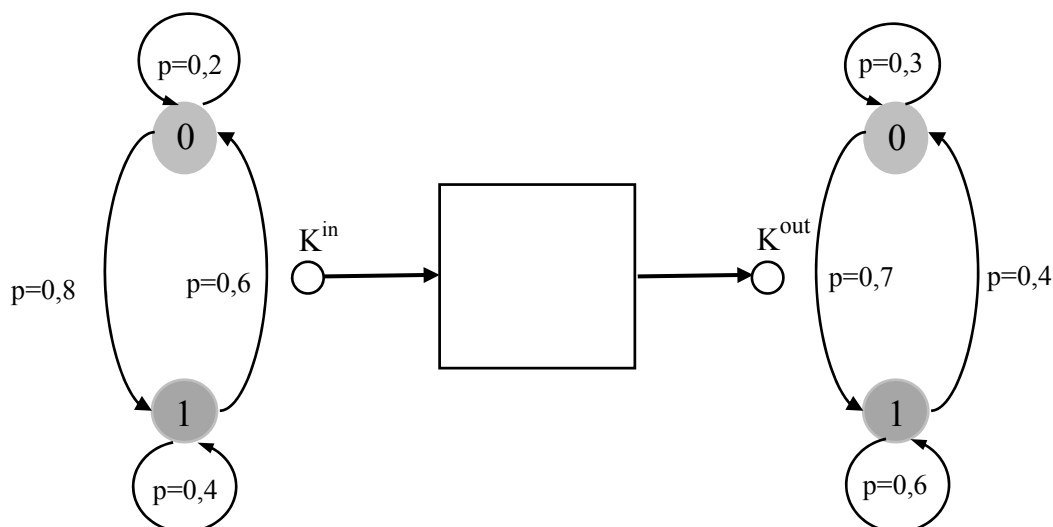

Figure 2a. Two-channel stochastic system object with two binary input and output channels and graphs of their states

Trimming is achieved by extending the time changes that lead to the loss of functionality associated with input channels.

An example of a two-channel object is shown in Fig. 2a, along with a matrix of stochastic transitions in Table 2a.

Table 2a. Stochastic state change matrix
(source: based on Ostrowska, Krupa, Wiśniewski, 2015)

0	1	2	3	4	5	6
1	state	00	01	10	11	-
2	00	0.06	0.14	0.24	0.56	1
3	01	0.08	0.12	0.32	0.48	1
4	10	0.18	0.42	0.12	0.28	1
5	11	0.24	0.36	0.16	0.24	1

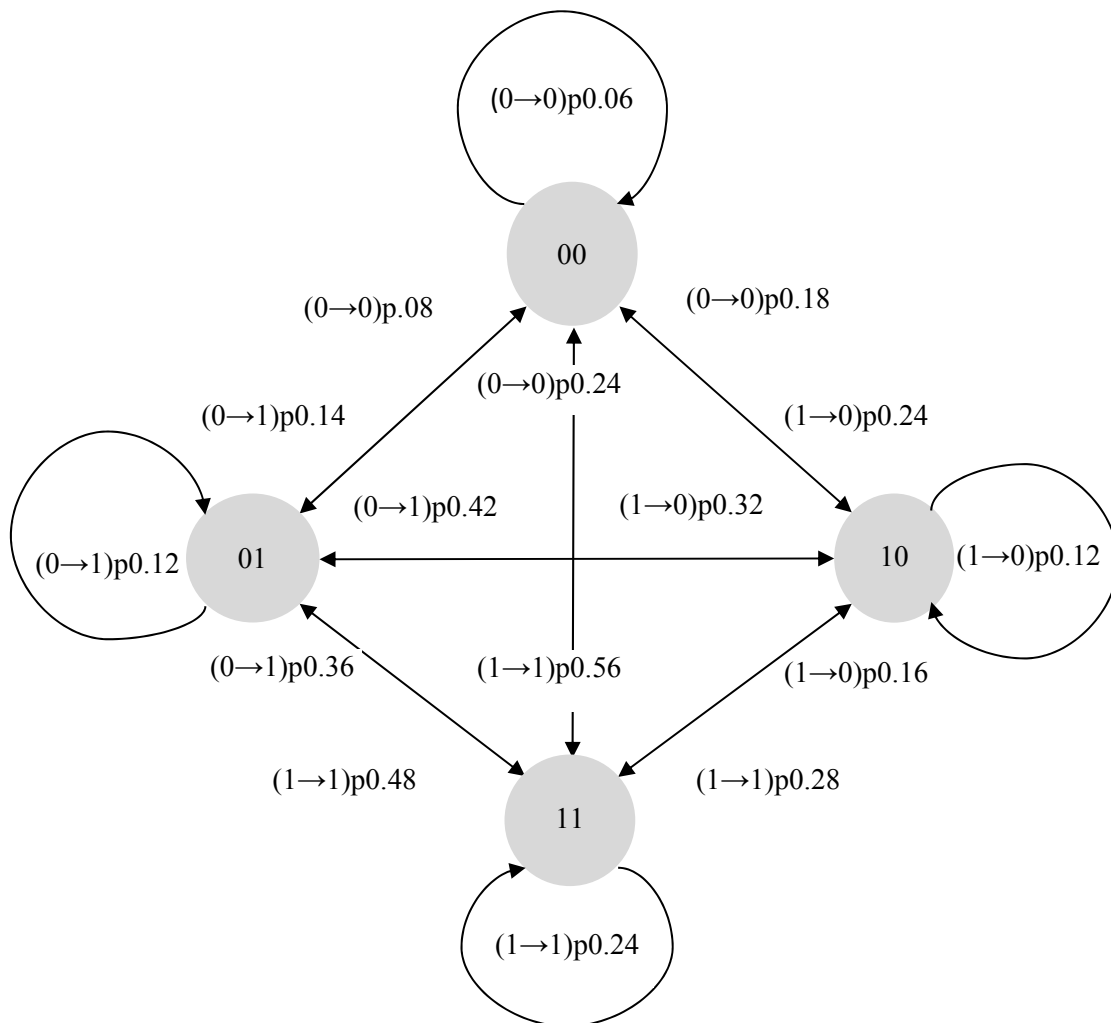

Figure. 2b. Stochastic state diagram with four pairs of events on the input and output channels of the object: 00, 01, 11, 10 (source: Ostrowska, Krupa, Wiśniewski, 2015)

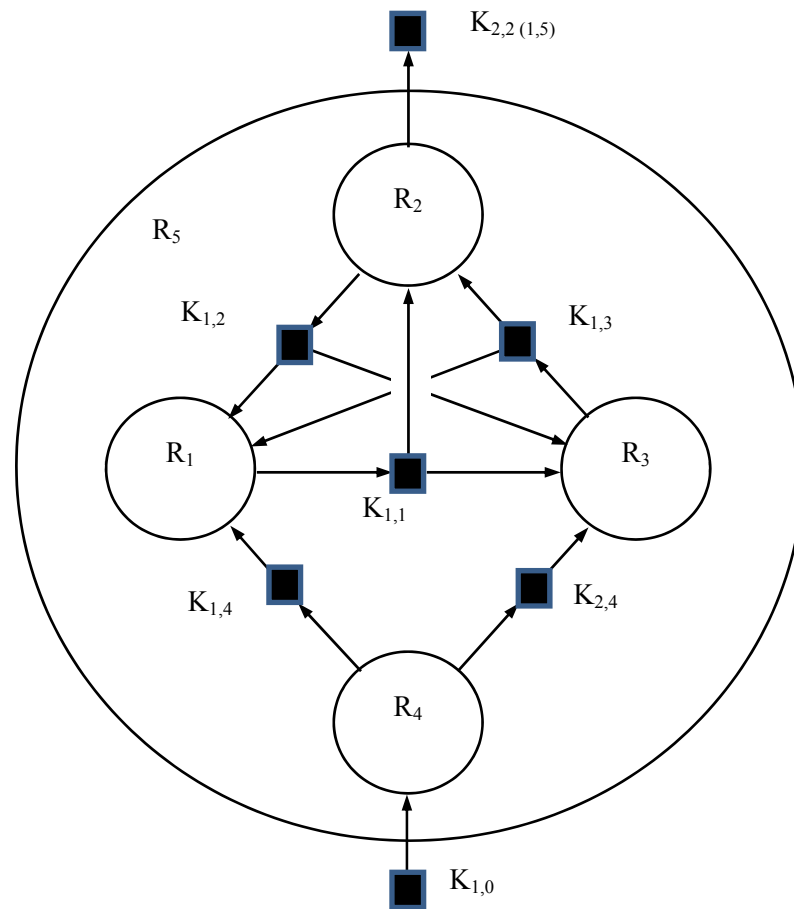

Figure. 3a. The resource and its associated components as threat model cluster
(source: Ostrowska, 2013)

The matrices show that, because of the appropriate strategy (trajectory) of the order of changes in the stochastic channel state, which is a model of the cluster of threats (Fig. 2b), the probability of loss of functionality can be significantly reduced. The importance of defending against catastrophic loss of functionality is to increase the number of output channels and their states in the structure of a cluster of threats.

The use of the resource-based approach allows CI to be defined as systems and their associated functionally related facilities, such as buildings, equipment, and installations, as key services for the security of the state and its citizens to ensure the efficient functioning of public administrations, institutions, and entrepreneurs.

As it is noted in the National Critical Infrastructure Protection Program (NCIPP, 2013): *"Identifying objects, equipment, installations or services whose*

destruction or disruption could cause a crisis is a key step in the process of IK protection."

An essential condition for effective coordination of resource transformation processes is the deep recognition of their morphological characteristics and, above all, the functioning, structures, and availability, as well as the ability to process resources through processes (technologies) that change these characteristics.

In the accepted concept, threats occur; they occur as a result of the adverse effects between resources (pairs or nodes of resources) also including the impact within resources in relation: resource component²–resource containing³.

This situation is illustrated in Fig. 3a.

² Resource component is a direct part of the resource.

³ Resource containing may comprise one or more resources of components, some of which may constitute resource containing.

3 A cluster resource model for threats

Fig. 3a shows the configuration of the cluster resources of the threat. According to the interpretation, each resource containing multiple resources is theoretically becoming, by its structural and functional complexity, a potential threat cluster for itself and for the resources of its environment.

Resource configuration creates a resource containing R_5 , whose input and output channels (channels: $K_{1,0}$, $K_{1,5}$) are channels of resource components (resources: R_2 , R_4) with the environment. The output channel of any resource can be an input channel for the interaction of one or more configuration resources or its output channel. The resource interaction output channel is capable of autonomously remembering the impact value until the next forced change in the state of the impact.

Resources are described and grouped by the concept of the resource class resulting from the application of a multidimensional comparative analysis apparatus to the resource universe being the subject of analysis and operational activities (Kieżun, 1997; Korzeniowski, 2012; Zawila-Niedźwiecki, 2009; Zawila-Niedźwiecki, 2010). Group analysis of resources should be conducted in a confraternity⁴ system that seeks to find technology synergies to make the threat cluster an effective tool against countless and unexpected external and internal threats.

In this interpretation, a cluster of threats is understood as a set of threats to the distinguished group of resources. Resources and threats included in the cluster can create layered threats (network) and hierarchical relationships, which can be interpreted as threat clusters of a pyramidal structure as a result; this approach allows the flexibility to administer the system of crisis management adequately to an evolving scenario of events. In this case, the crisis situation is understood as a situation that affects the level of security of people, property, or the environment, causing significant limitations on public service delivery by the state's CI systems as well as restrictions on public administration.

⁴ Confraternity – an organization that seeks to find and apply technological synergies to make it an effective tool to counter diverse and unexpected circumstances.

Formally, a crisis situation is a situation in which the expected effects of hazard(s) have reached the critical level determined by the hazard threshold H^5 , also called the discontinuity threshold. Exceeding threshold H may lead to a crisis understood as a significant or total loss of functionality because of the inadequacy of the forces and resources in relation to the scale of the threat and the resulting effects.

4 Resource classes

Each resource class should have a specific (optional) repertoire of features that should include:

- 1) characterizing the resources;
- 2) defining the geographical allocation of resources;
- 3) representing the parameters relating to the effects of the destruction or cessation of the operation of the resource corresponding to the cross-cutting criteria defined in the *National Critical Infrastructure Protection Program* (NCIPP, 2013, p.11), which include: (a) victims in terms of people, (b) financial consequences, (c) necessity of evacuation, (d) loss of service, (e) time of reconstruction, (f) international effect, (g) uniqueness;
- 4) specifying the status of the resource as acceptable at max.–min. limits in order to allow the introduction of hazard information;
- 5) an attribute informing about the significance of the resource(s) in the CI system;
- 6) features that determine its susceptibility to damage, disruption of functionality, reduced capacity or performance, or misuse;
- 7) features useful for analytical purposes for risk analysis and for the development of scenarios for the development of adverse events (e.g., to be identified in further stages of development work on CI fragment).

The repertoire of features should be unified for all CI to allow for the development and application of the

⁵ H hazard score or acceptable level of loss of functionality – such a situation on the indicated channel, resource, infrastructure, or combination of those that reached the breakpoint H risk expressed in terms of the product value $P \times U \times Z \geq 50\%$, where $H = 50\%$ is determined a priori, for example, assuming that: probability $P = 0.8$, probability (submission) $U = 0.8$ and hazard value $Z = 80\%$; the next level of $P = 0.9$, $U = 0.9$, and $Z = 90\%$ will result in an increase of nearly 50% in $H = 73.9\%$.

same tools for operational data collection, reporting, aggregation, analytics, and decision support.

The distinction of the characteristics of resources of a class occurs whenever we come to the description of a different class of resources, and in this case, when there are different repertoires of values within the same set of characteristics.

The dynamics of changes in the value of the characteristics of a resource should take into account only the most important characteristics in terms of ensuring the continuity of the correct functioning of a given resource class. Failure to comply with this rule (an excessive number of features with a significant number of allowable values) – because of exponential increase in complexity – will make it impossible to estimate the effects of resource interactions. For example, only for 15 attributes of resource A with 5 values for each attribute, we obtain about 30.5×10^9 states of this resource. If resource A interacts with the resource complexity B in an analogy, then the number of possible states of such a system will increase to 9.3×10^{19} . It is clear that simplification in the description of normal⁶ and critical⁷ interactions (and therefore threats) must be conducted and evaluated in a manner that guarantees their adequacy for the purpose function of maintaining CI's continuity.

The foregoing considerations show that CI's business continuity analysis can be effective (with the potential for effective risk mitigation) when conducted only with "highly simplified" tools for modeling logic and the potential for external influences (EI) and internal impacts (II) are identified in resource structures.

Logical modeling of the continuity mechanisms is also possible using spatial hypergraph structures. On the other hand, the modeling of the potential

⁶ Normal effects – such a situation on the indicated channel, resource, infrastructure, or combination of those that has reached the point of discontinuity H expressed in terms of the product value $P \times U \times Z < 50\%$, where the value of gambling $H = 50\%$.

⁷ Critical impact – this situation on the indicated channel, resource, infrastructure, or combination of those that has reached the point of discontinuity H expressed conventionally by the product of $P \times U \times Z \geq 50\%$, where the hazard value $H = 50\%$ is determined a priori.

impacts of weakening or enhancing of the functional aspects of CI resources can be modeled using additive operations on the potential risks calculated with the dynamics (speed and acceleration) of the changes. The development of flat methodological examples of the detailed positioning of threats in resource structures should not present significant difficulties (Ostrowska, 2013).

5 Logic of structures and resource transformations in technology reactors

An essential condition for achieving effective coordination of resource transformation processes is to recognize their morphological characteristics and, above all, their functioning, structures, and availability, as well as the ability to process resources through processes (technologies) that change these characteristics.

Among the above-mentioned morphological characteristics are dynamic phenomena and, in particular, the identification of dynamics of internal states of objects based on their mutual a priori and a posteriori influences (Krupa, 2017).

The purpose of research on the essence of resources is, among other reasons:

- optimal use of resources and, in particular, the increase in efficiency and reliability of resource transformation technology processes (cost reduction and reduction of resource transformation time),
- increased operational reliability of reactors and transforming networks (ensuring continuity, minimizing the risk of network operation, designing processes that coordinate the logistics processes of resources).

Because of the variety of relationships that exist between resources that can be formulated to define the links between the physical elements of a subject area, it is necessary to define the possible relationships between resources and their aggregates.

Relationships between resources are required to be independent (invariant) of any imaginary situation (scene) existing or potentially possible in the subject area in question. Identifying what the resource is and how it creates the structures (or less formally, collections and compositions) of resources enables one to create new, more perfect concepts, methods of mod-

eling and description tools, and simulations of their functioning.

It is imperative to build such a modeling apparatus by which it will be possible to overcome the barriers of the size and the complexity of the research and design systems. The size barrier can be overcome if we use a sufficiently fast computer; the barrier to complexity can be avoided by means of heuristic models and methods.

The transformational and informational transformations of altered and processed resources form a resource system (dynamic grouping) called a technology reactor, which aims to accomplish one of the two tasks:

- the task of synthesizing or decomposing resources,
- the task of analyzing or controlling the processing of resources.

In addition to the transformational resource in the implementation of the task, support resources and hypothetical resources may also occur. Supportive resources are used as "catalysts" accompanying transformation processes, while hypothetical resources describe the desired transformation (model).

In the case of synthesis or decomposition tasks, the transforming resource implements the procedure of synthesis or decomposition or transformation, respectively (the transformation procedure is a special case of the decomposition procedure when a resource of altered traits or attributes is created as a result of the transformation process). In the case of analysis or control tasks, the transforming resource implements an analysis or a control procedure, respectively.

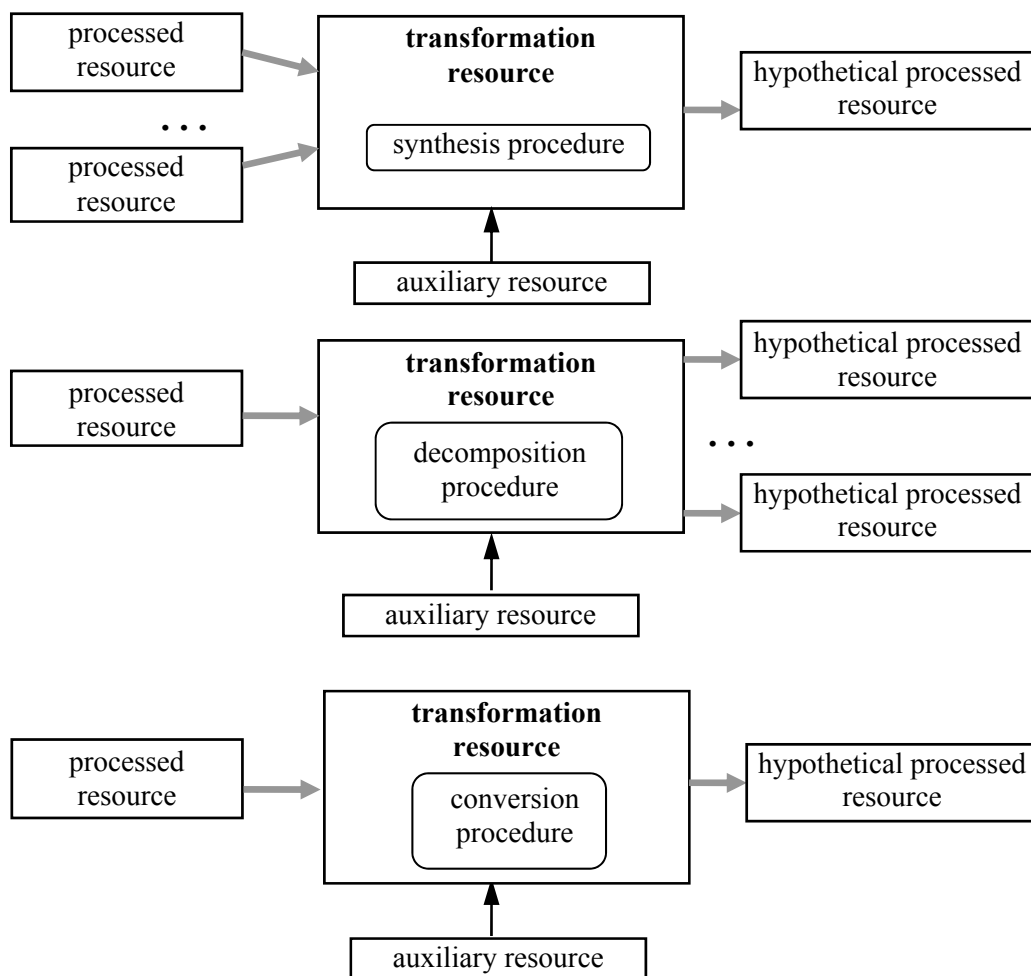

Figure 5a. Transformations of structural resources (source: Krupa, 2006; Ostrowska, Krupa, 2014)

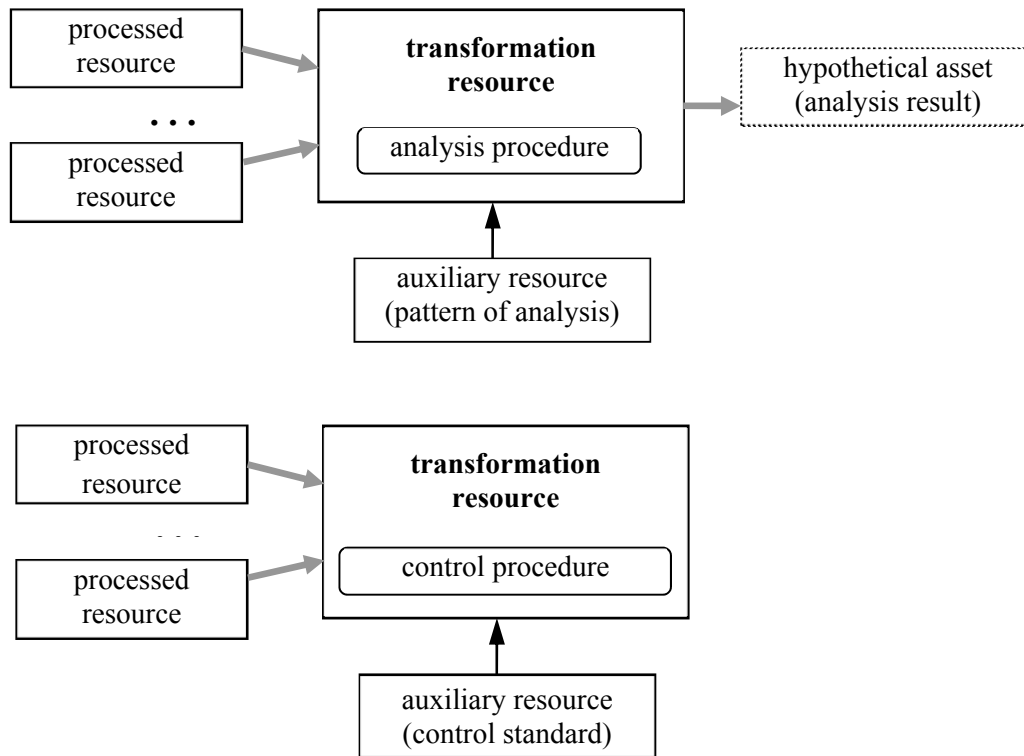

Figure 5b. Transformations of functional resources
(source: Krupa, 2006)

A transformed resource can interact with an input resource within the range of the desired structure or within the desired functionality of the output resources. Structural transformations of resources are presented in Fig. 5a (the next variants of transformation are synthesis, decomposition and transformation).

Functional transformations of resources are presented in Fig. 5b (possible variants of functional transformation are analysis and control). In both types of effects of a transforming resource on an input resource, the role played by the control norm (or plan of analysis) is that of a "hypothetical asset".

In the physical world, the impact of a transformational resource is related to technological operations that change physicochemical, mechanical, electrical, organizational, or other properties. Compounds of information resources are subjected to transformations, as are their structural and functional physical compounds.

As a result of information transformations, the processing (transfer, storage, and transformation) of re-

source information is improved. Improved processing of information is accompanied by modifications to the structural linkages of resources. The relationships r1–r5, shown in Fig. 5c, have been used to distinguish the structural relationships established between the resources of the technology reactor.

Information actions, in terms of functioning, consist of changing the value of input characteristics of input resources and observing the values of output characteristics. On the basis of the observation of changes in the value of the output characteristics, the transformation resource control procedure determines the desired values of the input characteristics.

The information impact on the structure of the resource consists of their nomenclature, recall, and compilation; the resulting functional relationships can guarantee the resolution of defined (hypothetical) tasks of synthesis or decomposition and analysis or control. These operations are implemented by the transforming resource.

The stock can be subjected to three types of structural operations:

- the operations that result in determining the resource class (set of resource attributes) and the resource type (because of the attribute values of the resource),
- operations that result in a change in the resource class (change of feature set) or change in resource type (change in at least one set of attribute values of this resource); for obvious reasons, not all variants of such changes must be acceptable,

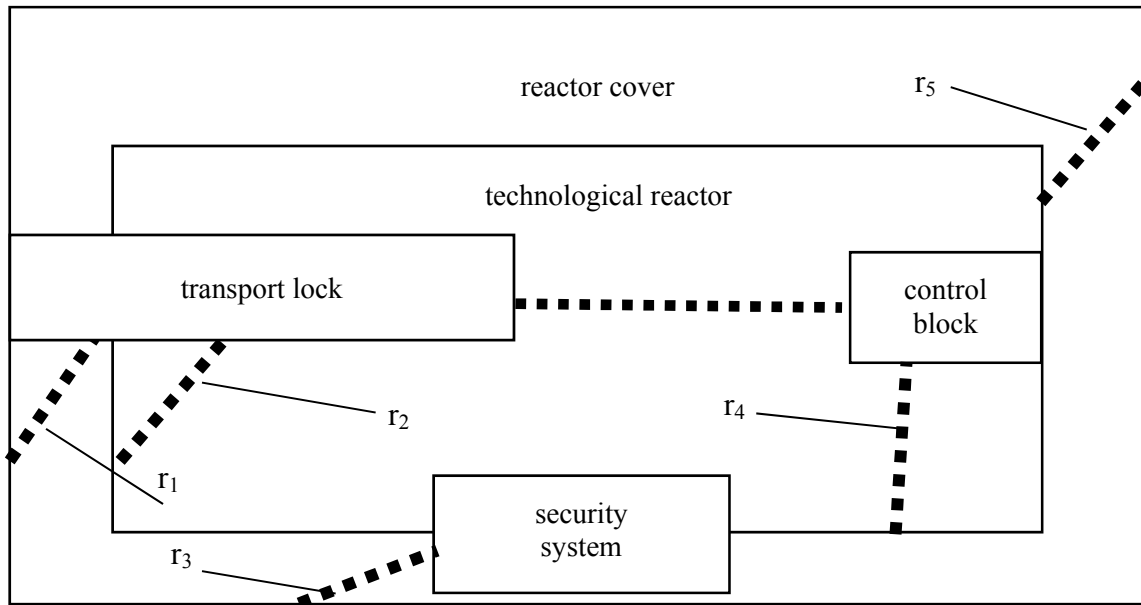

Figure 5c. An example of a resourceful interpretation of a technology reactor
(source: Ostrowska, Krupa, 2014)

- operations that result in one of the four actions in relation to the resource collection:
 - resources are added to the community,
 - the resource is removed from the community,
 - the resource in the community is exchanged for an external resource not belonging to the community in question,
 - checks regarding whether the given community contains a specific resource.

Investigation of the substance of the threat is due to the consequences of human interaction, material objects and physical phenomena, leading to an increase in the risk of adverse events, and in the event of a significant increase in the occurrence of a crisis situation, leading to the consequent need for risk assessment.

Estimation of the risk of technology reactors is the determination of the probability of its occurrence (as a relation between the aggregation of events that have occurred and which may be the cause of the

incidents, and the collective occurrence of the risk) and the amount of the determined loss (using new value, replacement value, or book value and intermediate loss). The risk should be expressed in the form of a risk assessment model and a risk management model (including risk transfer).

Risk is a function (consequence) of two phenomena: threat and vulnerability. Risk assessment in a specific area of activity that is subject to observation and assessment is the starting point for building a crisis management system (CMS), the essence of which is to make decisions under time constraints in the event of a threat to key functions in the technology reactor zone and its environment.

This statement implies the need to establish a working definition for a group of initial concepts, and then to expand (develop) these concepts in accordance with the needs of the crisis management plan.

A group of basic concepts are the following keywords: resource, event, process, scenario, decision, threat, risk, and crisis.

Each of the above concepts is the starting point for defining and developing a system of concepts that govern the methods of risk assessment and the

risk assessment and the management of crisis situations. A well-constructed ontology (system of concepts) of the area of activity in question can significantly influence the architecture (spatial structure) and the functioning (effectiveness) of the CMS.

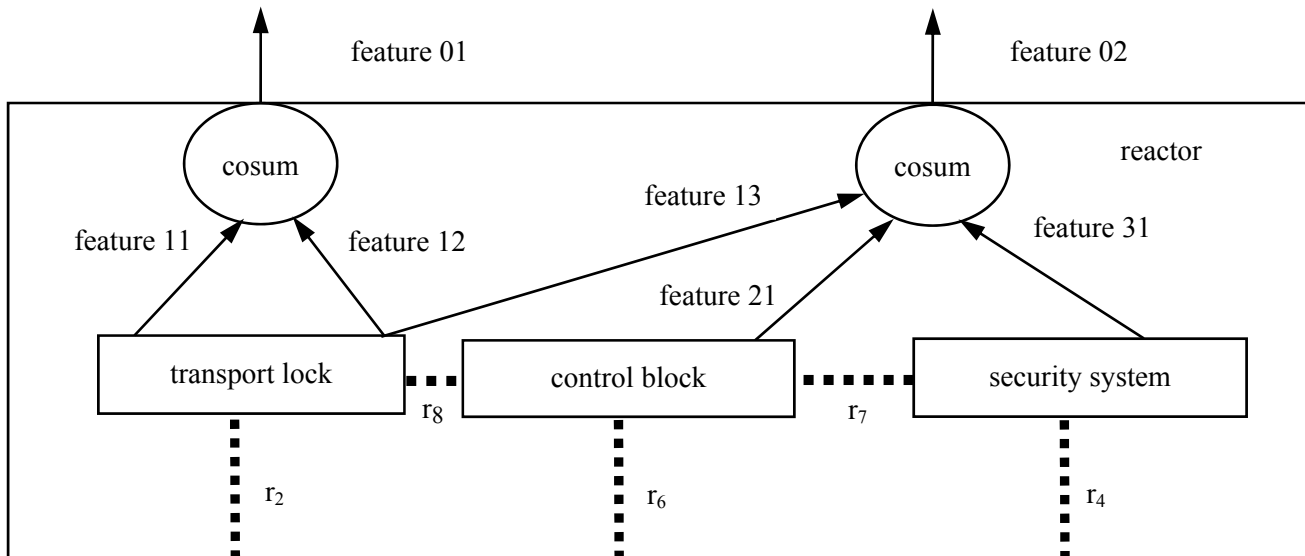

Figure 5d. Structural resources in the technology reactor
(source: Ostrowska, Krupa, 2014)

The simplicity of structure and efficiency are key to building a hierarchical (pyramid) CMS where pyramids are found to contain material objects or physical phenomena treated as resources, technology reactors, and associated operators⁸.

And in the intermediate layers, up to the highest level, there are operating managers responsible for preventing, coordinating, and leveling crisis situations through adequately managed processes.

The model of the technology reactor shown in Fig. 5d illustrates the phenomenon of system summation of the external resources of the internal technology reactor (transport lock, control block, security system) into the external characteristics of the external resource (the technology reactor) interacting by coincidental sums (cosums) and relations (r_2 , r_4 and r_6) on the reactor cover.

The structural and functional transformations described earlier should be included in the control procedures that affect the input and output channels of the objects, which also interact with one another based on the relationships occurring in the technology reactors.

6 Example of a technology reactor

Fig. 6a presents a simple example of a chemical reactor with a functionality characteristic of technology reactors, the task of which is to synthesize two factors Cz1, Cz2 fed by valves ZCz1, ZCz2 into a factor of Cz3.

Valves ZCz1, ZCz2 can be open OtZCz1, OtZCz2 or closed ZaZCz1, ZaZCz2, which is directly encoded in the event name.

The reactor is filled up to the required level first by factor Cz1, controlled by the sensor PCz1, and then to the required level factor Cz2, controlled by the sensor PCz2.

⁸ They are managing persons or organizational units.

Before starting these processes, the chemical reactor is fully emptied, the lower valve ZCz1 is closed, and the first high valve is opened until the first desired level PCz1 is reached.

Then, the second upper valve ZCz2 is opened until the second desired level PCz2 is reached. Immediately after, the valve ZCz2 is closed and the stirrer Mi is switched on (state MiOn).

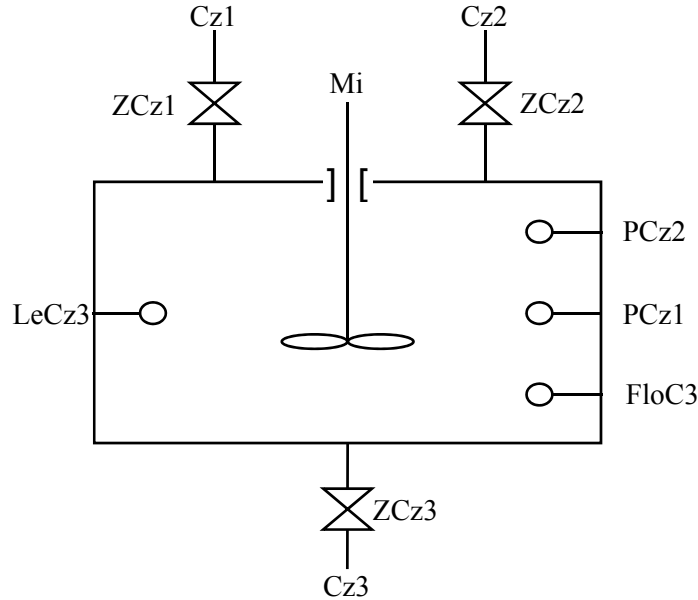

Figure 6a. An example of a chemical reactor

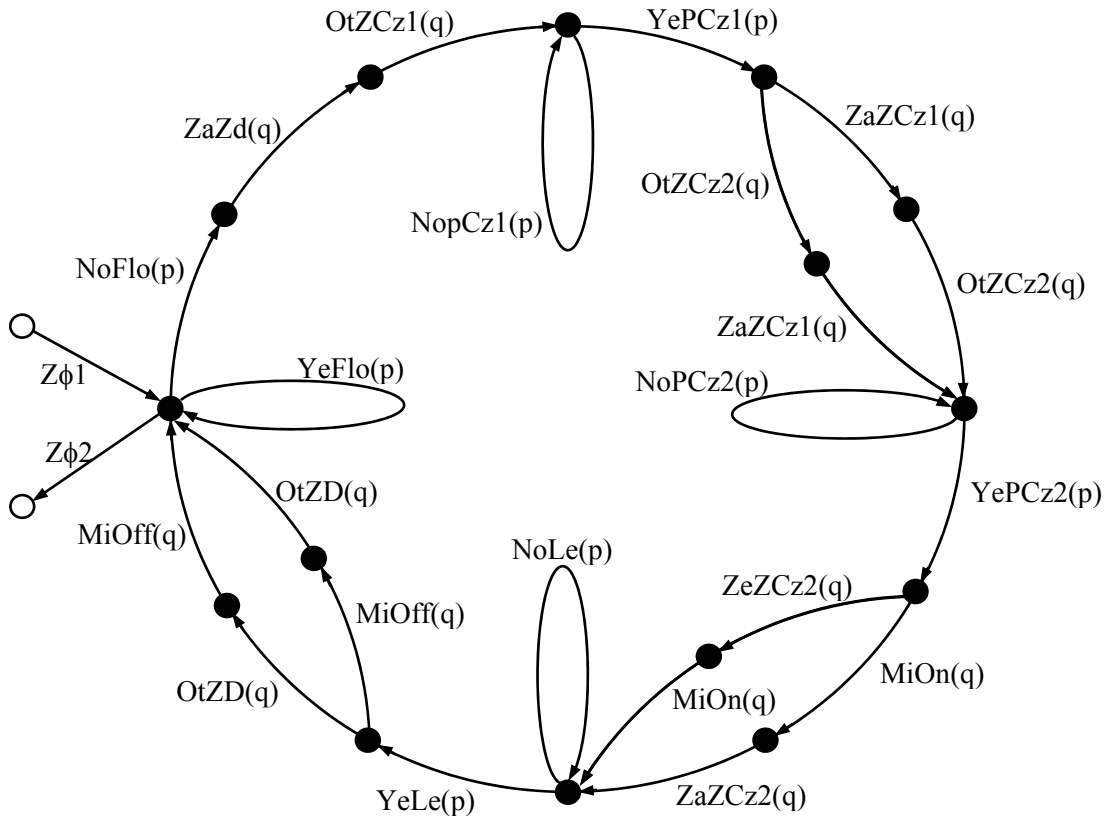

Figure 6b. Event network for the example of chemical reactor shown in Fig. 6a

After obtaining a suitable viscosity for the medium Cz3 controlled by the sensor LeCz3, the stirrer Mi is switched off (state MiOff) and the lower valve ZCz3 is opened. The output of the synthesis product is controlled by the sensors FloCz3. When the reactor is empty, the technological process begins with the closing of the lower valve ZCz3.

Sensors, valves, and reactor stirrer are interpreted as object channels. Forced status changes to these channels are treated as class events (q). Controlled state changes to these channels are treated as class (p) events. The forced (q) and controlled (p) event symbols are appended to the identifiers of the events shown.

Channels and states of the reactor channels:

- channel: ZCz1 – factor valve Cz1 ⇒ states: OtZCz1 open, ZaZCz1 closed
- channel: ZCz2 – factor valve Cz2 ⇒ states: OtZCz2 open, ZaZCz2 closed
- channel: PCz1 – sensor level factor Cz1 ⇒ states: YePCz1 / NoPCz1 there is level / no level
- channel: PCz2 – sensor level factor Cz2 ⇒ states: YePCz2 / NoPCz2 there is level / no level
- channel: ZCz3 – bottom valve ⇒ states: OtZCz3 open, ZaZCz3 closed
- channel: FloCz3 – flow sensor ⇒ states: YeFloCz3 / NoFloCz3 there is flow / no flow
- channel: Mi – stirrer ⇒ states: MiOn / MiOff stirrer on / stirrer off
- channel: LeCz3 – viscosity sensor ⇒ states: YeLeCz3 / NoLeCz3 there is viscosity / no viscosity

Force-induced events (q) in the chemical reactor:

- OtZCz1(q), ZaZCz1(q),
- OtZCz2(q), ZaZCz2(q),
- OtZCz3(q), ZaZCz3(q),
- MiOn(q), MiOff(q).

Class-controlled events (p) in the chemical reactor:

- YePCz1(p), NoPCz1(p),
- YePCz2(p), NoPCz2(p),
- YeLeCz3(p), NoLeCz3(p),
- YeFloCz3(p), NoFloCz3(p).

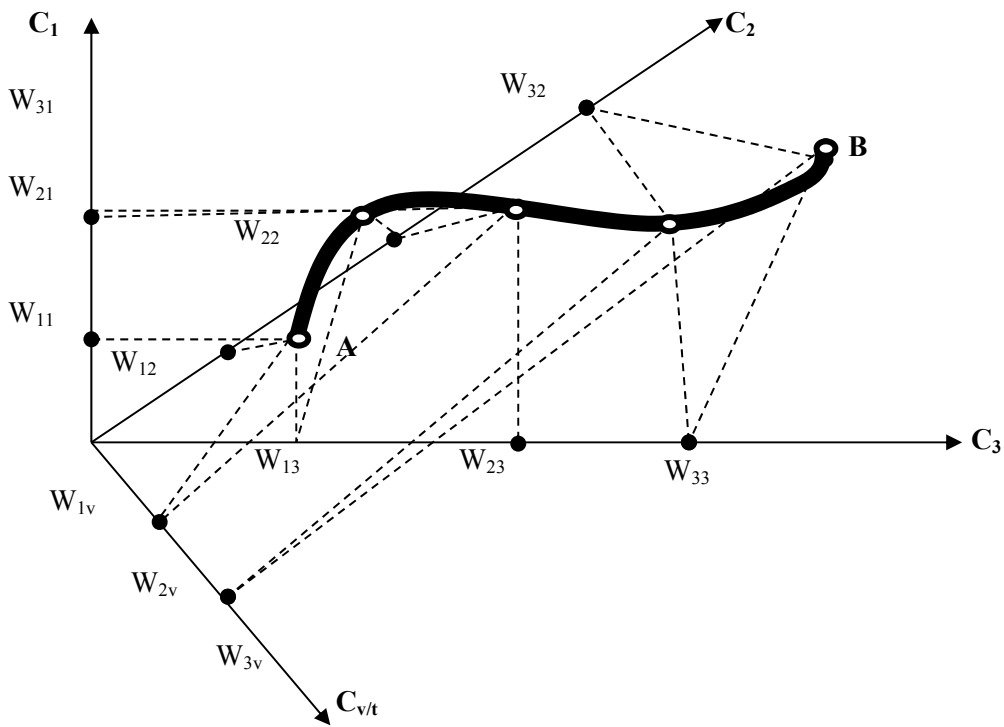

Figure 6c. Space and trajectory of resource values. The coordinate $C_{v/t}$ maps the value-change monitored point in time (source: Krupa, 2006; Ostrowska, Krupa, 2014)

Fig. 6b shows the network of events implemented in the chemical reactor channels shown in Fig. 6a.

Fig. 6c shows the trajectory of changes in the value of resource attributes (e.g., chemical reactors) between the points marked A and B without changing its class (i.e., without changing the repertoire of attributes for this resource).

Recognition and analysis of acceptable trajectory values of resource attributes (in the interpretation of channel states) can be used to find optimal solutions at the time of a threat of collision of unexpected changes in channel state values, which in this case may function as a threat cluster.

In theoretical considerations, one should assume the presence of both negative (threat) and positive (positive) effects. These impacts accumulate as a result of the synergistic effect of the simultaneous operation of many resources. Impact modeling can help to prevent, compensate and mitigate hazards in an emergency situation.

7 Conclusion

The theory of the interpretation of various phenomena identified in the literature points to the systematic "timeless" meaning of this concept, as well as to the timeless concept of "network" in all its possible forms of logistics, computers, communication, and so on.

In the article summary, we would like to draw the reader's attention to the three distinguishing determinants of resource theory in the areas of CI:

- structural and functional relationships between CI resources can be expressed in a manner appropriate to the characterization principle of V.A. Gorbatov (Krupa, 2013), which points to the necessity of observing the isomorphic function of structural–functional maps,
- from the structural and functional relationships of resources originates the hypothesis of the universality of the term "resource" in the world of material values and in the world of virtual invariants of structural and functional values,

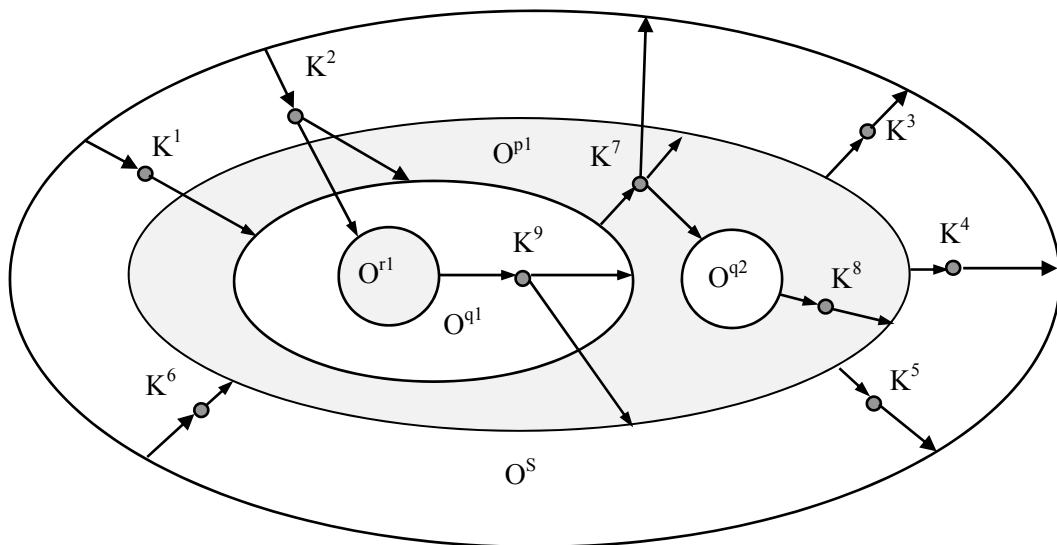

Figure 7a. Hypergraph structure of objects and connecting channels (source: Krupa, Maj, 2010; Krupa, Wiśniewski, 2015a; Krupa, Ostrowska, 2017)

- the internal and external security issues organized by the CI with the use of hypergraph structures of objects and their internal and external channels (Fig. 7a) are considered to be the basic value of the concept of the resource and related terms.

A single internal output channel of an object (e.g., channel K^2 of an O^S object) may be an external input channel for any number of objects located within that object. The O^S object in Fig. 7a represents the environment of the technological reactor.

Channels K^1 , K^2 , and K^6 are the internal output channels of the O^S object affecting the technology reactor objects. The K^3 , K^4 , and K^5 channels are external output channels of the O^{P1} technology reactor facility that interacts with the O^S environment in question.

8 References

- [1] Belz, G., Skalik, J., 2011. *Systemowe stymulanty strategicznej odnowy przedsiębiorstw. Na styku języka zasobów i procesu (Systemic Stimulants of Strategic Business Renewal. At the Interface of Resource and Process Language)*. In: (Krupski, 2011, pp.219-234).
- [2] Czakon, W., 2011. *Zasobowa teoria firmy – ograniczenia w badaniu zjawisk międzyorganizacyjnych (The Resource-Based Theory of the Firm - Limitations in the Study of Interorganizational Phenomena)*. In: (Krupski, 2011, pp.185-198).
- [3] Domański, J., Kotarba, W., Krupa, T., 2014. The Prisms of Management. *Foundations of Management*, Vol. 6, No. 2, Warsaw: Warsaw University of Technology, pp.43-50, DOI: 10.1515/fman-2015-0010.
- [4] Ficoń, K., 2007. *Inżynieria zarządzania kryzysowego. Podejście systemowe (Crisis Management Engineering. System approach)*. Warszawa: BEL Studio.
- [5] Frączkiewicz-Wronka, A., 2011. *Podejście zasobowe w zarządzaniu organizacją publiczną – perspektywa interesariuszy (Resource-based Approach in Public Organization Management - Stakeholder Perspective)*. In: (Krupski, 2011, pp.281-310).
- [6] Gospodarek, T., 2011. *Użyteczność oraz aspekty behawioralne w modelu RBV (Usability and Behavioral Aspects in the RBV Model)*. In: (Krupski, 2011, pp.59-84).
- [7] Jajuga, K. (ed.), 2007. *Zarządzanie ryzykiem (Risk Management)*. Warszawa: PWN.
- [8] Jelonek, D., 2011. *Ocena poziomu harmonizacji strategii ogólnej i strategii funkcjonalnych w przedsiębiorstwie (Assess the Level of Harmonization of the Overall Strategy and Functional Strategies within the Enterprise)*. In: (Krupski, 2011, pp.323-344).
- [9] Kaleta, A., 2011. *Relacje między zasobowym i pozycyjnym podejściem do zarządzania strategicznego we współczesnych przedsiębiorstwach (The Relationship between Resource and Positional Approach to Strategic Management in Modern Enterprises)*. In: (Krupski, 2011, pp.23-36).
- [10] Kieżun, W., 1997. *Sprawne zarządzanie organizacją. Zarys teorii i praktyki (Efficient Management of the Organization. An Outline of Theory and Practice)*. Warszawa: Wydawnictwo SGH.
- [11] Korzeniowski, L.F., 2012. *Podstawy nauk o bezpieczeństwie. Zarządzanie bezpieczeństwem (The Basis of Safety Science. Safety Management)*. Warszawa: Difin.
- [12] Kosieradzka, A., Zawila-Niedźwiecki, J., 2016. *Zaawansowana metodyka oceny ryzyka w publicznym zarządzaniu kryzysowym (Advanced risk Assessment Methodology in Public Crisis Management)*. Kraków: edu-Libri.
- [13] Krupa, T., 2006. *Elementy organizacji. Zasoby i zadania (Organizational Elements. Resources, and Tasks)*. Warszawa: WNT.
- [14] Krupa, T., 2009a. Events and Event Processes. *Foundations of Management*, Vol. 1, No. 2, Warsaw: Warsaw University of Technology, pp.143-158, DOI: 10.2478/v10238-012-0016-9.
- [15] Krupa, T., 2009b. Modelowanie procesów dyskretnych w aksjomatyce teorii charakteryzacji Gorbатов'a (Modeling Discrete Processes in the Axiomatic of Gorbатов's Characterization Theory). In: T., Krupa (ed.). *Wybrane zagadnienia informatyki gospodarczej (Selected Issues of Digital Economy)*. Warszawa: Oficyna PTZP, ISBN 978-83-923797-8-2.
- [16] Krupa, T., 2013. V.A. Gorbатов Theory of Characterization – Principles and Examples. *Foundations of Management*, Vol. 5, No. 3, Warsaw: Warsaw University of Technology, pp.89-102, DOI: 10.2478/fman-2014-0022.
- [17] Krupa, T., 2014a. Modelowanie procesów decyzyjnych w systemach zarządzania kryzysowego – podejście zasobowe (Modeling of Decision Processes in Crisis Management Systems – the Resource-Based Approach). Konferencja: *Inno-*

- wacyjność w Procesach Zarządzania i Dowodzenia Organizacjami Publicznymi (Conference: *Innovation in the Processes of Management and Command of Public Organizations*), Wydział Zarządzania i Dowodzenia Akademii Obrony Narodowej (Department of Management and Command of the National Defense Academy), Warszawa 15.05.2014.
- [18] Krupa, T., 2014b. Operacje na sieciach zdarzeń (Operations on Event Networks). *Logistyka (Logistics)*, No. 5, pp.851-861, CD1.
- [19] Krupa, T., 2015. Semiotyka kluczowych pojęć tezauryśa ciągłości działania w infrastrukturze krytycznej (Semiotics of Key Thesaurus Concepts of Business Continuity in Critical Infrastructure). *Logistyka (Logistics)*, No. 4, pp.7793-7802, CD.
- [20] Krupa, T., 2017. Elements of Theory of the Correct Operations of Logistics Transforming Networks. *Foundation of Management*, Vol. 9, Warsaw: Warsaw University of Technology, pp.347-360, DOI: 10.1515/fman-2017-0026.
- [21] Krupa, T., Maj, K., 2010. The Management Method Preventing a Crisis Situation. *Foundations of Management*, Vol. 2, No. 2, Warsaw: Warsaw University of Technology, pp.37-50, DOI: 10.2478/v10238-012-0027-6.
- [22] Krupa, T., Ostrowska, T., 2012. Decision-making in Flat and Hierarchical Decision Problems. *Foundations of Management*, Vol. 4, No. 2, Warsaw: Warsaw University of Technology, pp.23-36, DOI: 10.2478/fman-2013-0008.
- [23] Krupa, T., Ostrowska, T., 2017. Prakseologiczne aspekty teorii zdarzeń – symetria zagrożeń i podatności (Praxeological Aspects of Events Theory - Symmetry of Threats and Vulnerabilities). In: W., Kieżun, J., Wołjszo (eds.). *Prakseologia w zarządzaniu i dowodzeniu. Ekonomiczność w zarządzaniu (Praxeology in Management and Leadership. Economics in Management)*. Kalisz: Państwowa Wyższa Szkoła im. Prezydenta Stanisława Wojciechowskiego w Kaliszu, pp.67-82, ISBN 978-83-65872-09-8.
- [24] Krupa, T., Wiśniewski, M., 2015a. Situational Management of Critical Infrastructure Resources under Threat. *Foundations of Management*, Vol. 07, Warsaw: Warsaw University of Technology, pp.93-104, DOI: 10.1515/fman-2015-0028.
- [25] Krupa, T., Wiśniewski, M., 2015b. Wykorzystanie wiedzy w zarządzaniu sytuacyjnym bezpieczeństwem infrastruktury krytycznej Polski (Use of Knowledge in Situational Management of Critical Infrastructure Security in Poland). *Logistyka (Logistics)*, No. 5, pp.1027-1034, CD.
- [26] Krupski, R. (ed.), 2011. *Rozwój szkoły zasobowej zarządzania strategicznego (Development the Resource-Based School of Strategic Management)*. Wałbrzych: Wałbrzyska Wyższa Szkoła Zarządzania i Przedsiębiorczości, ISBN 978-83-60904-13-8.
- [27] *NCIPP (National Critical Infrastructure Protection Program)*, 2013, <http://rcb.gov.pl/wp-content/uploads/NPOIK-dokument-glowny.pdf>.
- [28] Ostrowska, T., 2013. The Resource Hazards Model for the Critical Infrastructure of the State Emergency Management Process. *Foundations of Management*, Vol. 5 No. 3, Warsaw: Warsaw University of Technology, pp.49-60, DOI: 10.2478/fman-2014-0019.
- [29] Ostrowska, T., Krupa, T., 2014. Przetwarzanie zasobów w sieciach technologicznych (Processing of Resources in Technological Networks). In: *Logistyka (Logistics)*, Warszawa, 5/2014, pp.1189-1198 (CD).
- [30] Ostrowska, T., Krupa, T., Wiśniewski, M., 2015. Dynamic Hazards in Critical Infrastructure of State. *Foundation of Management*, Vol. 7, Warsaw: Warsaw University of Technology, pp.143-158, DOI: 10.1515/fman-2015-0032.
- [31] Romanowska, M., 2011. Zasobowe ograniczenia reorientacji strategicznej (Resources Restriction of Strategic Reorientation). In: (Krupski, 2011, pp.37-44).
- [32] Skomra, W., 2010. *Zarządzanie kryzysowe – praktyczny przewodnik po nowelizacji ustawy (Crisis Management - a Practical Guide to the Amendment of the Act)*. Wrocław: Presscom.
- [33] Sobolewski, G., 2010. Zarządzanie kryzysowe wobec współczesnych wyzwań i zagrożeń (Crisis Management Considering to Contemporary Challenges and Threats). In: E., Sobczak (ed.). *Nowe wyzwania i wykorzystanie współczesnej nauki w zarządzaniu kryzysowym (New Challenges and the Use of Contemporary Science in Crisis Management)*. Warszawa: WAI NS PW, pp.45-58.

- [34] Zawila-Niedzwiecki, J., 2009. Operational Risk and the Security of an Organization. In: J., Monkiewicz, L., Gąsioriewicz, (eds.). *Risk Management. Concepts, Models, Issues*. Warszawa: Dom Wydawniczy Elipsa, pp.135-148.
- [35] Zawila-Niedzwiecki, J., 2010. Pojęcie ryzyka operacyjnego i klasyfikacja jego rodzajów (Definition of Operational Risk and Classification of its Types). *Przegląd Organizacji (Review of the Organization)*, No. 6, Warszawa: TNOiK, pp.19-22.
- [36] Zawila-Niedzwiecki, J., 2013. *Zarządzanie ryzykiem operacyjnym w zapewnianiu ciągłości działania organizacji (Operational Risk Management in Ensuring Business Continuity)*. Kraków: edu-Libri.
- [37] Zawila-Niedzwiecki, J., 2014. Analiza ryzyka operacyjnego z perspektywy teorii organizacji (Operational Risk Analysis from the Perspective of Organizational Theory). *Zeszyty Naukowe Wydziału Nauk Ekonomicznych i Zarządzania (Scientific Papers Department of Economic Sciences and Management)*, seria: Finanse, Rynki Finansowe, Ubezpieczenia (Series: Finance, Financial Markets, Insurance), No. 51, Szczecin: Uniwersytet Szczeciński, pp.179-189.
- [38] Zawila-Niedzwiecki, J., 2014. Metodyka analizy ryzyka w ochronie infrastruktury krytycznej państwa (Methodology of Risk Analysis in Protection of Critical Infrastructure of the State). *Zeszyty Naukowe Wydziału Nauk Ekonomicznych i Zarządzania (Scientific Papers of Department of Economic Sciences and Management)*, seria: Finanse, Rynki Finansowe, Ubezpieczenia (Series: Finance, Financial Markets, Insurance), No. 65, Szczecin: Uniwersytet Szczeciński, pp.791-797.
- [39] Zawila-Niedzwiecki, J., 2014. Operational Risk as a Problematic Triad: Risk – Resource Security – Business Continuity. Kraków: edu-Libri, ISBN: 978-83-63804-42-8.