

Kushnir, Alexey; Liu, Shuo

Working Paper

On linear transformations of intersections

Working Paper, No. 255

Provided in Cooperation with:

Department of Economics, University of Zurich

Suggested Citation: Kushnir, Alexey; Liu, Shuo (2017) : On linear transformations of intersections, Working Paper, No. 255, University of Zurich, Department of Economics, Zurich, <https://doi.org/10.5167/uzh-137636>

This Version is available at:

<https://hdl.handle.net/10419/173415>

Standard-Nutzungsbedingungen:

Die Dokumente auf EconStor dürfen zu eigenen wissenschaftlichen Zwecken und zum Privatgebrauch gespeichert und kopiert werden.

Sie dürfen die Dokumente nicht für öffentliche oder kommerzielle Zwecke vervielfältigen, öffentlich ausstellen, öffentlich zugänglich machen, vertreiben oder anderweitig nutzen.

Sofern die Verfasser die Dokumente unter Open-Content-Lizenzen (insbesondere CC-Lizenzen) zur Verfügung gestellt haben sollten, gelten abweichend von diesen Nutzungsbedingungen die in der dort genannten Lizenz gewährten Nutzungsrechte.

Terms of use:

Documents in EconStor may be saved and copied for your personal and scholarly purposes.

You are not to copy documents for public or commercial purposes, to exhibit the documents publicly, to make them publicly available on the internet, or to distribute or otherwise use the documents in public.

If the documents have been made available under an Open Content Licence (especially Creative Commons Licences), you may exercise further usage rights as specified in the indicated licence.



**University of
Zurich** ^{UZH}

University of Zurich
Department of Economics

Working Paper Series

ISSN 1664-7041 (print)
ISSN 1664-705X (online)

Working Paper No. 255

On Linear Transformations of Intersections

Alexey Kushnir and Shuo Liu

June 2017

ON LINEAR TRANSFORMATIONS OF INTERSECTIONS

Alexey Kushnir and Shuo Liu*

June 3, 2017

Abstract

For any linear transformation and two convex closed sets, we provide necessary and sufficient conditions for when the transformation of the intersection of the sets coincides with the intersection of their images. We also identify analogous conditions for non-convex sets, general transformations, and multiple sets. We demonstrate the usefulness of our results via an application to the economics literature of mechanism design.

Keywords: *linear transformation, convex closed set, intersection, directional convexity, mechanism design, dominant-strategy implementation, Bayesian implementation*

1 Introduction

Let $T : \mathbb{R}^n \rightarrow \mathbb{R}^m$ be a linear transformation for some $m, n \in \mathbb{N}$ and $A, B \subset \mathbb{R}^n$ be two convex closed sets with a non-empty intersection. Generally, the transformation of the intersection $T(A \cap B)$ is a subset of the intersection of their images $TA \cap TB$. In this paper, we provide necessary and sufficient conditions for these sets to *coincide*, i.e., $T(A \cap B) = TA \cap TB$. To the best of our knowledge, this question has not been addressed previously.

Specifically, in Section 2, we provide conditions that exploit the *directional convexity* and *path-connectedness* of the union $A \cup B$ and their relation to the kernel of the linear transformation. As shown in Section 3, these conditions can be extended to non-convex sets, non-linear transformations, and multiple sets. To further deepen our understanding of the problem, in Section 4, we

*Alexey Kushnir: Tepper School of Business, Carnegie Mellon University, Posner Hall 237, Pittsburgh, PA 15213, USA; Shuo Liu: Department of Economics, University of Zürich, Schönberggasse 1, CH-8001, Zürich, Switzerland. Email: alexey.kushnir@gmail.com and shuo.liu@econ.uzh.ch. We are very grateful to Itai Ashlagi, Egon Balas, Heinz Bauschke, Jérôme Bolte, Boris Bukh, Keenan Crane, Patrick Combettes, Gerard Cornuejols, Federico Echenique, Alfred Galichon, Ben Golub, Sergiu Hart, Fatma Kılınç-Karzan, Michael McCoy, Javier Pena, Marek Pycia, R Ravi, Stephen Spear, Rakesh Vohra, Josephine Yu, Weijie Zhong and seminar participants at Columbia University, Carnegie Mellon University, and the University of Pittsburgh for discussions and useful suggestions.

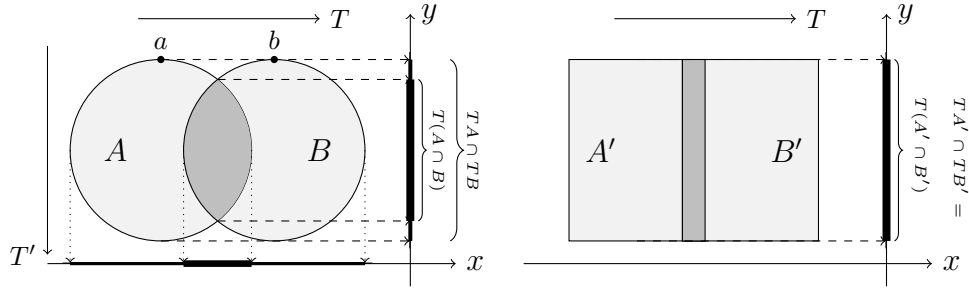

Figure 1. The orthogonal projection of discs A and B (left) along the x -axis (transformation T) and the y -axis (transformation T'). $TA \cap TB \neq T(A \cap B)$ and $T'A \cap T'B = T'(A \cap B)$ because $A \cup B$ is not convex in the direction of the x -axis, but is convex in the direction of the y -axis. For rectangles A' and B' (right), $TA' \cap TB' = T(A' \cap B')$ for *any* linear transformation T because union $A' \cup B'$ is convex.

consider a different set of conditions that rely on the properties of *support points* of the convex sets. Finally, in Section 5, we demonstrate how our results can be applied to study the design of robust mechanisms for selling goods—a problem that has recently attracted attention in the economics literature of mechanism design (see, e.g., Manelli and Vincent, 2010; Gershkov, Goeree, Kushnir, Moldovanu and Shi, 2013).

2 Convex Closed Sets

To motivate, let us first consider a simple example. The left panel of Figure 1 presents two discs of the same radius $A, B \subset \mathbb{R}^2$ with non-empty intersection. If we project the discs along the x -axis, we obtain $TA \cap TB \neq T(A \cap B)$, where T is the projection operator. The transformation of the intersection of the sets does not coincide with intersections of their images because there exist points $a \in A$ and $b \in B$ that have the same image, but the line connecting them contains no points of $A \cap B$. Note that such a situation is not possible when the union $A \cup B$ is convex, as the right panel of Figure 1 shows. This observation leads to our first result.

Theorem 1. *For any linear transformation T and convex closed sets A and B , if the union $A \cup B$ is convex, then $T(A \cap B) = TA \cap TB$.*

PROOF. Consider any $A, B \subset \mathbb{R}^n$, linear $T : \mathbb{R}^n \rightarrow \mathbb{R}^m$, and $t \in TA \cap TB$. By definition, there exist $a \in A$ and $b \in B$ such that $Ta = Tb = t$. As $A \cup B$ is convex, we have $[a, b] \subset A \cup B$. Moreover, $[a, b] \cap A = [a, c_1]$ for some $c_1 \in [a, b] \cap A$. Similarly, $[a, b] \cap B = [c_2, b]$ for some $c_2 \in [a, b] \cap B$. As $[a, c_1] \cup [c_2, b] = [a, b]$, we have $[a, c_1] \cap [c_2, b] \neq \emptyset$, and thus there must exist some $c \in [a, b] \cap A \cap B$. By the linearity of T , we also have $t = Tc \in T(A \cap B)$. Hence, $T(A \cap B) = TA \cap TB$. \square

Remark. The convexity of the union of sets $A \cup B$ is also a *necessary* condition for $T(A \cap B) = TA \cap TB$ for *all* linear transformations $T : \mathbb{R}^n \rightarrow \mathbb{R}^{n-1}$ (see Theorem A1 in the Appendix).

Theorem 1 provides a sufficient condition for $T(A \cap B) = TA \cap TB$ to be true for *any* linear transformation T . However, if only a specific transformation T is of interest, this condition might be too demanding. For example, even though the union of the two discs in the left panel of Figure 1 is not convex, for projection T' along the y -axis, we nevertheless have $T'(A \cap B) = T'A \cap T'B$. Intuitively, this is the case because there is no gap between sets A and B along the direction of the projection T' . This motivates us to introduce the following concept of *directional convexity*.¹

Definition 1. A set $C \subset \mathbb{R}^n$ is convex in direction $d \in \mathbb{R}^n$ if for all $a, b \in C$ with $a - b = \alpha d$ for some $\alpha \in \mathbb{R}$, we have $[a, b] \subset C$.

The left panel of Figure 1 shows that the union of discs A and B is convex in the direction parallel to the y -axis. Denoting the kernel of a linear transformation $T : \mathbb{R}^n \rightarrow \mathbb{R}^m$ as $\ker(T) = \{a \in \mathbb{R}^n : Ta = 0\}$, we establish the following result.

Theorem 2. For a linear transformation T and convex closed sets A and B , if the union $A \cup B$ is convex in every direction $d \in \ker(T)$, then $T(A \cap B) = TA \cap TB$.

PROOF. The proof follows the steps of the one of Theorem 1. We omit it to avoid repetition. \square

Nevertheless, the convexity of the union with respect to the directions in the kernel is not generally a necessary condition. To illustrate, consider the two right triangular prisms A and B in Figure 2 and suppose we project them orthogonally along the xy -plane onto the z -axis. The projection of the intersection coincides with the intersection of the prisms' images. However, the union of the prisms is not convex with respect to the direction of the x -axis, which belongs to $\ker(T)$. To state our necessary condition, we introduce the following definition.

Definition 2. A set $C \subset \mathbb{R}^n$ is path-connected with respect to $\ker(T)$ of linear transformation $T : \mathbb{R}^n \rightarrow \mathbb{R}^m$ if the inverse image

$$T_C^{-1}(t) = \{a \in C \mid a - b \in \ker(T) \text{ for some } b : Tb = t\}$$

is path-connected for all $t \in TC$, where TC refers to the image of C .

¹Aumann and Hart (1986) previously introduced a similar concept of bi-convex sets that are convex with respect to two orthogonal directions.

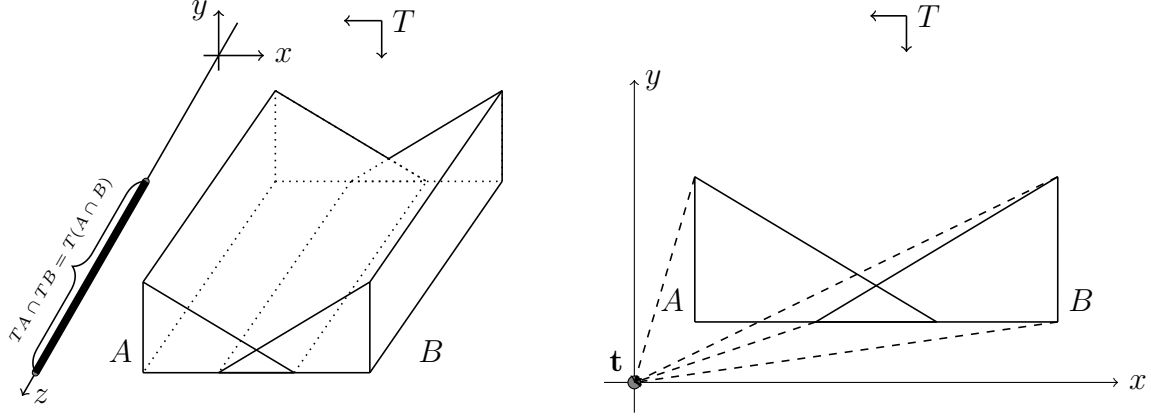

Figure 2. The left panel shows the orthogonal projection T of prisms A and B along the xy -plane on the z -axis. The right shows the inverse image of a given point $t \in TA \cap TB$.

The right panel of Figure 2 presents the inverse image $T_{A \cup B}^{-1}(t)$ for some $t \in TA \cap TB$. Obviously, this is not a convex set. Nevertheless, this set is path-connected. It turns out that this is not a coincidence: That sets $T_{A \cup B}^{-1}(t)$ are path-connected for all $t \in T(A \cup B)$ is both necessary and sufficient for $T(A \cap B) = TA \cap TB$. This result is formally stated and proved in the next theorem.

Theorem 3. *For a linear transformation T and convex closed sets A and B ,*

$$T(A \cap B) = TA \cap TB$$

if and only if $A \cup B$ is path-connected with respect to $\ker(T)$.

PROOF. (*If statement*) Consider any $t \in TA \cap TB$. By definition, there exist $a \in A$ and $b \in B$ such that $Ta = Tb = t$. As $T_{A \cup B}^{-1}(t)$ is path-connected there exists a path $P(a, b) \subset T_{A \cup B}^{-1}(t)$ connecting a and b . Moreover, $P(a, b) \cap A = P(a, c_1)$ is a path for some $c_1 \in P(a, b) \cap A$. Similarly, $P(a, b) \cap B = P(c_2, b)$ is a path for some $c_2 \in P(a, b) \cap B$. As $P(a, c_1) \cup P(c_2, b) = P(a, b)$, we must have $P(a, c_1) \cap P(c_2, b) \neq \emptyset$. This implies that there exists some $c \in P(a, b) \cap A \cap B$. Because $c \in T_{A \cup B}^{-1}(t)$, we also have $t = Tc \in T(A \cap B)$. Hence, $T(A \cap B) = TA \cap TB$.

(*Only-if statement*) Consider any $a \in A \cup B$. Suppose first that $t = Ta \notin TB$, and hence $T_{A \cup B}^{-1}(t) = T_A^{-1}(t)$. In this case, the inverse image $T_{A \cup B}^{-1}(t)$ is path-connected because set A is convex and T is linear. Similarly, if $Ta \notin TA$, we have $T_{A \cup B}^{-1}(t) = T_B^{-1}(t)$, which is again path-connected. Finally, suppose that $t = Ta \in TA \cap TB$ and, without loss of generality, $a \in A$. As

A is convex and T is linear, point a is path-connected to any point in $T_{A \cup B}^{-1}(t) \cap A$. Let us now consider some $b \in T_{A \cup B}^{-1}(t) \cap B$. As $T(A \cap B) = TA \cap TB$, there exists $c \in A \cap B$ such that $t = Tc$. As a result, $c \in A \cap B \cap T_{A \cup B}^{-1}(t)$. Therefore, point c is path-connected with both a and b within $T_{A \cup B}^{-1}(t)$, which further implies that a is also path-connected with b within $T_{A \cup B}^{-1}(t)$. \square

Note that if $A \cup B$ is convex with respect to every direction in $\ker(T)$, the union is also path-connected with respect to $\ker(T)$. In fact, in this case, any two points $a, b \in T_{A \cup B}^{-1}(t)$ are connected with a straight line. Theorem 3, thus, weakens the sufficient condition of Theorem 2 by allowing points of the union to be connected with some path that is not necessarily a straight line.

3 Extensions

In this section, we show that the conditions set out in Section 2 can be extended to non-convex sets, general non-linear transformations, and multiple sets. We start by noting that the sufficiency part of Theorem 3 does not require sets A and B to be convex. Moreover, as the following result shows, the convexity assumption in the necessity part can be replaced with a weaker requirement whereby sets A and B are both path-connected with respect to $\ker(T)$.

Theorem 4 (Non-Convex Sets). *Consider a linear transformation T and closed sets A and B that are path-connected with respect to $\ker(T)$. Then,*

$$T(A \cap B) = TA \cap TB$$

if and only if $A \cup B$ is path-connected with respect to $\ker(T)$.

PROOF. The proof of the if statement repeats the steps of the sufficiency proof of Theorem 3. For the necessity part, the path-connectedness of $T_{A \cup B}^{-1}(t)$ for points $t \in TA \cap TB$ follows from Theorem 5 presented below. In regard to points $t \notin TA \cap TB$, the path-connectedness of $T_{A \cup B}^{-1}(t)$ follows from the assumption that both A and B are path-connected with respect to $\ker(T)$. \square

The linearity assumption of the transformation can also be dropped. However, for non-linear transformations $a - b \in \ker(T)$ does not imply $Ta = Tb$. To address this problem, we reformulate the notion of the inverse image as $T_C^{-1}(t) = \{a \in C \mid Ta = t\}$. We can then modify the proof of Theorem 3 and obtain the following necessary and sufficient condition for general non-linear transformations.

Theorem 5 (Non-Linear Transformations). Consider any transformation T and closed sets A and B that have path-connected inverse images $T_A^{-1}(t)$ and $T_B^{-1}(t)$ for all $t \in TA \cap TB$. Then,

$$T(A \cap B) = TA \cap TB$$

if and only if the inverse image $T_{A \cup B}^{-1}(t)$ is path-connected for all $t \in TA \cap TB$.

PROOF. The proof of the “if-statement” repeats the steps of the sufficiency proof of Theorem 3. Let us prove the necessity statement. Consider any $t \in TA \cap TB$. By definition, there exist $a \in T_A^{-1}(t)$ and $b \in T_B^{-1}(t)$. As $T(A \cap B) = TA \cap TB$, there also exists $c \in A \cap B$ such that $Tc = t$. As $c \in T_A^{-1}(t)$ and $T_A^{-1}(t)$ is path-connected, there is a path in $T_A^{-1}(t)$ connecting c and a . Similarly, $c \in T_B^{-1}(t)$ implies that there is also a path in $T_B^{-1}(t)$ connecting c and b . But then, as $T_{A \cup B}^{-1}(t) = T_A^{-1}(t) \cup T_B^{-1}(t)$, there is a path in $T_{A \cup B}^{-1}(t)$ connecting a and b . \square

Similar to the convexity assumption in Theorem 1, the inverse images $T_A^{-1}(t)$ and $T_B^{-1}(t)$ being path-connected for all $t \in TA \cap TB$ is only needed for the only-if statement. The sufficiency part does not require this additional condition.

The analysis of two convex closed sets can be readily extended to multiple sets. Let A_1, \dots, A_J be $J \geq 2$ convex closed sets. First, we present a direct generalization of Theorem 2. In particular, the theorem below states that if the union of every pair of sets is convex in every direction in the kernel, then the transformation of the intersection of all sets coincides with the intersection of their images.

Theorem 6 (Multiple Sets - Sufficiency). For a linear transformation $T : \mathbb{R}^n \rightarrow \mathbb{R}^m$ and J convex closed sets A_1, \dots, A_J ,

$$T\left(\bigcap_{j=1}^J A_j\right) = \bigcap_{j=1}^J TA_j$$

if $A_j \cup A_{j'}$ is convex in every direction $d \in \ker(T)$ for all $j, j' \in \mathcal{J} \equiv \{1, \dots, J\}$.

PROOF. We prove the statement by induction. Consider some $t \in \bigcap_{j=1}^J TA_j$. By definition, there exists $x_1 \in A_1$ such that $Tx_1 = t$. In addition, as $A_1 \cup A_2$ is convex in every direction $d \in \ker(T)$, we know by Theorem 2 that there exists $x_2 \in A_1 \cap A_2$ such that $Tx_2 = t$.

Now suppose that there exists $x_j \in A_1 \cap \dots \cap A_j$ such that $Tx_j = t$. Consider some $y \in A_{j+1}$ such that $Ty = t$, which again exists by definition. As $A_i \cup A_{j+1}$ is convex in every direction $d \in \ker(T)$, we have $[x_j, y] \subset A_i \cup A_{j+1}$ for each $i = 1, \dots, j$. Hence, $[x_j, y] \subset (\cap_{i=1}^j A_i) \cup A_{j+1}$. As $\cap_{i=1}^j A_i$ and A_{j+1} are both convex and closed, we can conclude (similar to Theorem 1) that there must exist point $z \in (\cap_{i=1}^j A_i) \cap A_{j+1}$ such that $Tz = t$. \square

Similar to Theorem 2, the condition of Theorem 6 is not generally necessary. Our necessary and sufficient condition for multiple sets is obtained by mirroring the proofs of Theorems 3 and 5.

Theorem 7 (Multiple Sets - Characterization). *For a linear transformation T and J convex closed sets A_1, \dots, A_J ,*

$$T \left(\cap_{j=1}^J A_j \right) = \cap_{j=1}^J TA_j$$

if and only if $T_{(\cap_{i=1}^j A_i) \cup A_{j+1}}^{-1}(t)$ is path-connected for all $j = 1, \dots, J - 1$ and for all $t \in \cap_{j=1}^J T(A_j)$.

PROOF. (*If statement*) Without loss, let $J \geq 3$. Consider any $t \in \cap_{j=1}^J TA_j$. As $T_{A_1 \cup A_2}^{-1}(t)$ is path-connected and $t \in TA_1 \cap TA_2$, we have $t \in T(A_1 \cap A_2)$. Hence, $t \in T(A_1 \cap A_2) \cap TA_3$. Furthermore, as $T_{(A_1 \cap A_2) \cup A_3}^{-1}(t)$ is also path-connected, we have $t \in T(A_1 \cap A_2 \cap A_3)$. Repeating this argument, we will finally have $t \in T \left(\cap_{j=1}^J A_j \right)$. Therefore, $T \left(\cap_{j=1}^J A_j \right) = \cap_{j=1}^J TA_j$.

(*Only-if statement*) Consider any $t \in \cap_{j=1}^J TA_j$ and any $j \in \{1, \dots, J - 1\}$. By linearity and convexity, the sets $T_{\cap_{i=1}^j A_i}^{-1}(t)$ and $T_{A_{j+1}}^{-1}(t)$ are both path-connected. Now consider any point $a \in T_{\cap_{i=1}^j A_i}^{-1}(t)$ and any point $b \in T_{A_{j+1}}^{-1}(t)$. As $\cap_{j=1}^J TA_j = T \left(\cap_{j=1}^J A_j \right)$, there must exist point $c \in \cap_{j=1}^J A_j$ such that $Tc = t$. Because $c \in \cap_{i=1}^j A_i$ and $c \in A_{j+1}$, c is path-connected to both a and b within $T_{(\cap_{i=1}^j A_i) \cup A_{j+1}}^{-1}(t)$. Therefore, a and b are also path-connected within $T_{(\cap_{j=1}^k A_j) \cup A_{k+1}}^{-1}(t)$. \square

4 Dual Approach

In this section, we examine our research question from a dual perspective. In particular, by exploiting the properties of the support points of the closed convex sets, we provide a different set of conditions for when a linear transformation of intersection coincides with the intersection of their images.

First, we introduce some useful notations. For a set $C \subset \mathbb{R}^n$, we define its *support function* as

$$S^C(d) = \sup_{a \in C} a \cdot d$$

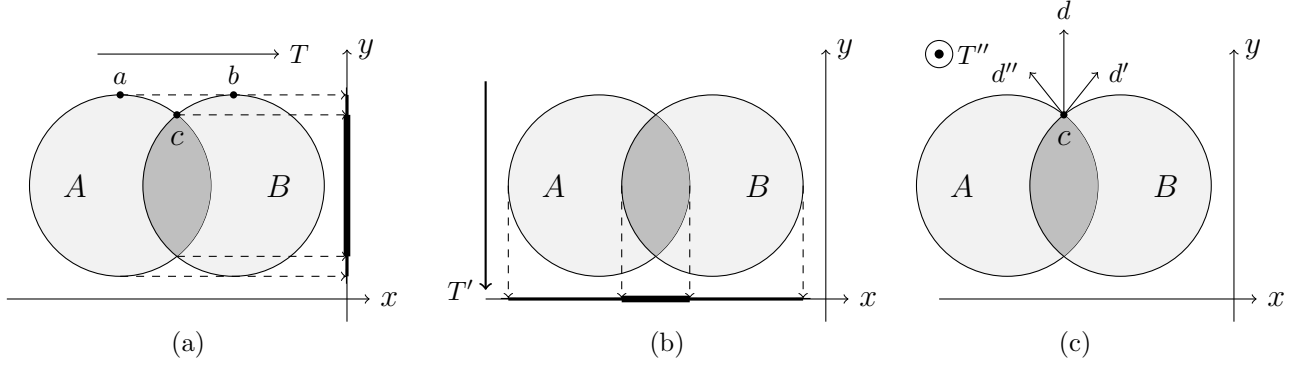

Figure 3. The orthogonal projections of discs A and B along the x -axis (a), the y -axis (b), and the axis orthogonal to the xy -plane (c).

for all $d \in \mathbb{R}^n$. We refer to $u \in \mathbb{R}^n$ as a *support point* of set C in direction $d \in \mathbb{R}^n$ if $u \in \arg \max_{a \in C} a \cdot d$. The set of all support points of set C in direction d is denoted as $E(C, d)$. Note that $E(C, 0) \equiv C$ and that $E(C, d)$ is guaranteed to be non-empty if C is compact. We also refer to the relative interior of set C as $\text{ri } C$.² In addition, for any linear transformation $T : \mathbb{R}^n \rightarrow \mathbb{R}^m$, we denote by $\ker(T)^\perp = \{a \in \mathbb{R}^n : a \cdot d = 0 \ \forall d \in \ker(T)\}$ the subspace orthogonal to $\ker(T)$. For simplicity, we assume that $n \geq m$ and $\dim(\text{image}(T)) = m$. This implies that $\ker(T)^\perp$ is a m -dimensional space.

To motivate the results in this section, consider a simple example as shown in Figure 3. We consider again two discs A and B with a non-empty intersection that belongs to the xy -plane and their three orthogonal projections along the x -axis, the y -axis, and the axis orthogonal to the xy -plane. The orthogonal projection of $A \cap B$ along the x -axis does not coincide with the intersection of the images (Figure 3a). Using the dual point of view, we can say that the problem arises because there exists a support point c of $A \cap B$ that is neither a support point of A nor a support point of B in the direction d orthogonal to the projection line, i.e., $d \in \ker(T)^\perp$. This implies that there must be distinct points a and b of sets A and B with a common image that lies above the image of point c .

However, this does not happen for projection T' along the y -axis (Figure 3b), where any support point of $A \cap B$ in the direction orthogonal to the projection line, i.e., $d \in \ker(T')^\perp$, is also a support point of one of the two sets in the same direction. This observation leads to our first sufficient condition in this section.

²Formally, the relative interior is defined by $\text{ri } C = \{a \in \text{aff } C \mid \exists \varepsilon > 0, B_\varepsilon(a) \cap \text{aff } C \subset C\}$, where $\text{aff } C$ is the affine hull of set C and $B_\varepsilon(a)$ is the Euclidean ball with radius ε and center a (see p. 44 in Rockafellar (1997)).

Theorem 8. For a linear transformation T and convex compact sets A and B ,

$$\forall d \in \ker(T)^\perp \quad E(A \cap B, d) \subseteq E(A, d) \cup E(B, d) \implies T(A \cap B) = TA \cap TB.$$

PROOF. See the Appendix. □

The condition of Theorem 8, however, is not generally necessary. This can be readily illustrated with projection T'' of the two discs along the axis orthogonal to the xy -plane (Figure 3c). Though $T''(A \cap B) = T''A \cap T''B$, point c is not a support point of either disc in the direction parallel to the y -axis, which belongs to $\ker(T'')^\perp$. Theorem 9 below shows that a necessary and sufficient condition requires any support point c of $A \cap B$ in direction $d \in \ker(T'')^\perp$ to be a support point of each set in some directions $d', d'' \in \ker(T'')^\perp$ with $d' + d'' = d$.

Theorem 9. For a linear transformation T and convex compact sets A and B with $\text{ri } A \cap \text{ri } B \neq \emptyset$,

$$T(A \cap B) = TA \cap TB$$

if and only if $\forall d \in \ker(T)^\perp$ and $\forall u \in E(A \cap B, d)$, $\exists d', d'' \in \ker(T)^\perp$ such that $d' + d'' = d$ and $u \in E(A, d') \cap E(B, d'')$.

PROOF. See the Appendix. □

While compact convex sets are fully characterized by their support points, for general closed convex sets, there might be directions without support points. Hence, to formulate a proper condition, we invoke the concept of the support function. As stated in the proof of Theorem 9, the support function for the intersection of sets $A \cap B$ with non-empty intersection of their relative interiors (i.e., $\text{ri } A \cap \text{ri } B \neq \emptyset$) can be conveniently characterized by³

$$S^{A \cap B}(d) = \inf_{\substack{d' + d'' = d \\ d', d'' \in \mathbb{R}^n}} (S^A(d') + S^B(d'')). \quad (1)$$

Our last necessary and sufficient condition states that for every direction $d \in \ker(T)^\perp$, we can limit ourselves in the above equation to a minimization among only directions $d', d'' \in \ker(T)^\perp$.

³The condition on relative interiors can be relaxed. In that case, for any $d \in \mathbb{R}^n$, we have

$$S^{A \cap B}(d) = cl \left(\inf_{\substack{d' + d'' = d \\ d', d'' \in \mathbb{R}^n}} (S^A(d') + S^B(d'')) \right),$$

where $cl f$ refers to the closure of f , i.e., $cl f(d) = \liminf_{d' \rightarrow d} f(d')$ (p. 78 in Hiriart-Urrut and Lemaréchal (2012)).

Theorem 10. For a given transformation T and convex closed sets A and B with $ri A \cap ri B \neq \emptyset$, $T(A \cap B) = TA \cap TB$ if and only if for any direction $d \in \ker(T)^\perp$

$$\inf_{\substack{d'+d''=d \\ d',d'' \in \mathbb{R}^n}} (S^A(d') + S^B(d'')) = \inf_{\substack{d'+d''=d \\ d',d'' \in \ker(T)^\perp}} (S^A(d') + S^B(d'')). \quad (2)$$

PROOF. See the Appendix. □

Though the above result seems to be rather technical, it proves to be very useful in the application considered in the following section.

5 Application

We now present an economic application of our main results to designing robust mechanisms for selling goods. To keep the exposition clear and transparent, we study only a simple example. Consider an auctioneer who wants to sell an object to two agents indexed by $i = 1, 2$. Agent i 's valuation of the object x^i can be one of two types, x_l or x_h , and it is independently distributed with equal probability. In addition, if agent i pays p^i to obtain the object his utility equals $x^i - p^i$.

Using the revelation principle (Myerson, 1979), we restrict our analysis to direct mechanisms, where agents are asked to report their types. Specifically, each mechanism specifies the probabilities that the object is allocated to agents and the payments requested from agents conditional on their reported types. To predict the outcome of a mechanism, economists typically consider two solution concepts. The first solution concept is Bayesian incentive compatibility (BIC), which requires that each agent reports his type truthfully given his belief about the distribution of the other agent types and that the other agents also report their types truthfully. The second solution concept is dominant-strategy incentive compatibility (DIC), which requires that each agent reports his type truthfully regardless of the other agents' reports and the realizations of their types.⁴ We apply the result of Theorem 10 to establish the following *BIC-DIC equivalence* result: For any BIC mechanism one could always construct an equivalent DIC mechanism that delivers the same interim allocation probabilities to all agents.⁵

⁴DIC is a rather demanding solution concept that guarantees good and robust behavior of agents in applications. In particular, it does not require that agents have a correct belief regarding the distribution of others' types, and it permits mistakes in agents' behavior. DIC mechanisms have been successfully adopted by many markets ranging from spectrum auctions (Milgrom, 2002) to labor markets for doctors, kidney exchange, and school choice in major US cities (Roth, 2008).

⁵Manelli and Vincent (2010) were the first to establish this result and Gershkov et al. (2013) extended it

To start with, note that any allocation of the object can be summarized by vectors $q^i = (q_{ll}^i, q_{lh}^i, q_{hl}^i, q_{hh}^i)$, $i = 1, 2$, where each element refers to the probability that agent i receives the object and the first (second) subscript refers to the first (second) agent's type. From agent 1's point of view, the expected probability of receiving an object equals $Q_l^1 = \frac{1}{2}q_{ll}^1 + \frac{1}{2}q_{lh}^1$ and $Q_h^1 = \frac{1}{2}q_{hl}^1 + \frac{1}{2}q_{hh}^1$, and similarly for agent 2. We refer to vectors $Q^i = (Q_l^i, Q_h^i)$, $i = 1, 2$ as interim allocation probabilities.

Two types of constraints shape the set of available allocation rules: feasibility constraints and incentive compatibility constraints. Feasibility constraints guarantee that the object is not allocated to two agents simultaneously.

$$\left\{ \begin{array}{l} q_{ll}^1 + q_{ll}^2 \leq 1 \\ q_{ll}^1, q_{ll}^2 \geq 0 \end{array} \right\}, \quad \left\{ \begin{array}{l} q_{lh}^1 + q_{lh}^2 \leq 1 \\ q_{lh}^1, q_{lh}^2 \geq 0 \end{array} \right\}, \quad \left\{ \begin{array}{l} q_{hl}^1 + q_{hl}^2 \leq 1 \\ q_{hl}^1, q_{hl}^2 \geq 0 \end{array} \right\}, \quad \left\{ \begin{array}{l} q_{hh}^1 + q_{hh}^2 \leq 1 \\ q_{hh}^1, q_{hh}^2 \geq 0 \end{array} \right\}. \quad (3)$$

Plainly, the feasibility set $C_F \subset \mathbb{R}^8$ defined by constraints (3) consists of a Cartesian product of four simplices. The support function for each simplex is easy to derive, e.g., $\max(0, d_{ll}^1, d_{ll}^2)$ is the support function of the first simplex. The support function of a Cartesian product of sets equals the sum of the support function. Hence, the support function of C_F for any $d \in \mathbb{R}^8$ equals

$$S^{C_F}(d) = \max(0, d_{ll}^1, d_{ll}^2) + \max(0, d_{lh}^1, d_{lh}^2) + \max(0, d_{hl}^1, d_{hl}^2) + \max(0, d_{hh}^1, d_{hh}^2). \quad (4)$$

Dominant strategy and Bayesian incentive compatibility constraints ensure that it is in the best interest of each agent to report his type truthfully. Laffont and Maskin (1980) showed that for any non-decreasing (ex post) allocation probabilities

$$\left\{ \begin{array}{l} q_{ll}^1 \leq q_{hl}^1 \\ q_{lh}^1 \leq q_{hh}^1 \end{array} \right\}, \quad \left\{ \begin{array}{l} q_{ll}^2 \leq q_{lh}^2 \\ q_{hl}^2 \leq q_{hh}^2 \end{array} \right\} \quad (5)$$

it is possible to find payments that jointly form a DIC mechanism. In addition, they showed that the above condition is also necessary for an allocation to be part of a DIC mechanism. We denote the above set of allocations as C_{DIC} and its support function as S^{DIC} . Similarly, BIC constraints reduce to the monotonicity of interim allocation probabilities

$$Q_l^1 \leq Q_h^1, \quad Q_l^2 \leq Q_h^2. \quad (6)$$

to social choice settings. Our treatment is, however, different from theirs, as it relies on the calculus of support functions. See Goeree and Kushnir (2017) for a fully developed approach to mechanism design that uses the calculus of support functions.

Let $T : \mathbb{R}^8 \rightarrow \mathbb{R}^4$ be the linear operator that transforms ex post allocations (q^1, q^2) into interim allocations (Q^1, Q^2) . Under transformation T , the DIC constraints (5) map onto the BIC constraints (6) and the feasibility constraints (3) onto the corresponding feasibility constraints at the interim level. The question of the BIC-DIC equivalence then reduces to the question of whether the transformation of the intersection $T(C_F \cap C_{DIC})$ coincides with $TC_F \cap TC_{DIC}$. We apply Theorem 10 to answer this question.

To this end, we first consider support function $S^{C_F \cap DIC^1}$ corresponding to the intersection of C_F with the DIC constraints of *only* agent 1. The support function for the DIC constraints of agent 1 equals

$$S^{DIC^1}(d) = \begin{cases} 0 & \text{if } d = \lambda_l^1(1, 0, -1, 0, 0, 0, 0, 0) + \lambda_h^1(0, 1, 0, -1, 0, 0, 0, 0), \\ +\infty & \text{otherwise} \end{cases}$$

for any $\lambda_l^1, \lambda_h^2 \geq 0$. Given the result of Theorem 10, we need to analyze the values of $S^{C_F \cap DIC^1}(d)$ only for directions $d \in \ker(T)^\perp$. Any such direction can be described by an 8-dimensional vector $d = (d_l^1, d_l^1, d_h^1, d_h^1, d_l^2, d_h^2, d_l^2, d_h^2)$. Taking into account that the support function of the intersection equals the convolution of the corresponding support functions (see equation (1)), we obtain

$$S^{C_F \cap DIC^1}(d) = \inf_{\lambda_l^1, \lambda_h^1 \geq 0} \max(0, d_l^1 - \lambda_l^1, d_l^2) + \max(0, d_l^1 - \lambda_h^1, d_h^2) + \max(0, d_h^1 + \lambda_l^1, d_l^2) + \max(0, d_h^1 + \lambda_h^1, d_h^2).$$

The above minimization problem has a solution at $\lambda^1 = \lambda_l^1 = \lambda_h^1 = \max(0, \frac{1}{2}(d_l^1 - d_h^1))$.⁶ Denote $\tilde{d}_l^1 = d_l^1 - \lambda^1$ and $\tilde{d}_h^1 = d_h^1 + \lambda^1$. Introducing the DIC constraints for agent 2, we similarly obtain

$$S^{C_F \cap DIC^1 \cap DIC^2}(d) = \inf_{\lambda_l^2, \lambda_h^2 \geq 0} \max(0, \tilde{d}_l^1, d_l^2 - \lambda_l^2) + \max(0, \tilde{d}_l^1, d_h^2 + \lambda_l^2) + \max(0, \tilde{d}_h^1, d_l^2 - \lambda_h^2) + \max(0, \tilde{d}_h^1, d_h^2 + \lambda_h^2).$$

The above minimization problem has again a solution at $\lambda^2 = \lambda_l^2 = \lambda_h^2 = \max(0, \frac{1}{2}(d_l^2 - d_h^2))$. Overall, for all $d \in \ker(T)^\perp$, there exists a vector $\lambda = (\lambda^1, \lambda^1, -\lambda^1, -\lambda^1, \lambda^2, -\lambda^2, \lambda^2, -\lambda^2) \in \ker(T)^\perp$ such that $S^{C_F \cap DIC}(d) = S^{C_F}(d - \lambda) + S^{DIC}(\lambda)$. Hence, the condition of Theorem 10 is satisfied and we have $T(C_F \cap C_{DIC}) = TC_F \cap TC_{DIC}$, which establishes the BIC-DIC equivalence result.

The purpose of the above example is to illustrate the use of our results rather than to derive

⁶The fact that the minimum is achieved at the same values of λ s has a deeper reason connecting the above minimization problem to majorization. See Goeree and Kushnir (2017) for a more detailed analysis.

novel insights in the economics literature. A detailed analysis of the BIC-DIC equivalence in linear social choice problems with independent one-dimensional types using techniques from convex analysis has been provided by Goeree and Kushnir (2017). The results of the present study, however, apply beyond linear settings and models with one-dimensional types. As such our result offer a new and productive way to study the BIC-DIC equivalence in much more general environments, which, however, is a topic for future research.

6 Conclusion

In this paper, we studied when a transformation of the intersection of two closed sets coincides with the intersection of their images. Using both primal and dual approaches, we provided necessary and sufficient conditions for any linear transformation and any two convex closed sets. We also identified analogous conditions for non-convex sets, general transformations, and multiple sets.

As an application, we showed how our results can be applied to designing robust mechanisms for selling goods. In fact, our results can be used to compare not only incentive compatibility constraints but also any interim and ex post constraints, including individual rationality, budget balance. We consider this to be an exciting direction for future research. We also believe our results will be of great use by research in the fields of operations research, convex analysis, and computer science.

Appendix

Theorem A1. *Consider two convex closed sets $A, B \subset \mathbb{R}^n$. If for all linear transformations $T : \mathbb{R}^n \rightarrow \mathbb{R}^{n-1}$ we have $T(A \cap B) = TA \cap TB$, then $A \cup B$ is convex.*

PROOF. Take some $a \in A$ and $b \in B$ such that $a \neq b$, and consider a surjective linear transformation $T : \mathbb{R}^n \rightarrow \mathbb{V}$, where $\mathbb{V} = \{v \in \mathbb{R}^n : v \cdot (x - y) = 0\}$ is $(n - 1)$ -dimensional. By construction, we have $a - b \in \ker(T)$ and $Ta = Tb = t$ for some $t \in \mathbb{R}^{n-1}$. As $t \in TA \cap TB = T(A \cap B)$, there exists $c \in A \cap B$ such that $Tc = t$. As $\dim(\ker(T)) = n - \dim(\mathbb{V}) = 1$, points a, b, c must lie on one straight line. As A and B are convex and $c \in A \cap B$, we have $[a, c] \subset A$ and $[b, c] \subset B$, which implies that $[a, b] \subset A \cup B$. Hence, $A \cup B$ is convex. \square

Proof of Theorem 8. As $T(A \cap B) \subset TA \cap TB$ and both $T(A \cap B)$ and $TA \cap TB$ are convex compact sets, it suffices to show that $E(T(A \cap B), d_m) \subset E(TA \cap TB, d_m)$ for all directions $d_m \in \mathbb{R}^m$, that is, every support point of $T(A \cap B)$ is also a support point of $TA \cap TB$ in the same direction. For this purpose, consider any direction $d_m \in \mathbb{R}^m$. Let $T^* : \mathbb{R}^m \rightarrow \mathbb{R}^n$ be the adjoint operator (or the transpose) of T . As $\text{image}(T^*) = \ker(T)^\perp$ (see p. 120 in Axler (1997)) we have $T^*(d_m) \in \ker(T)^\perp$. The condition of the theorem then ensures that $E(A \cap B, T^*(d_m)) \subseteq E(A, T^*(d_m)) \cup E(B, T^*(d_m))$. By the definition of adjoint operators, we further have $E(T(A \cap B), d_m) \subseteq E(TA, d_m) \cup E(TB, d_m)$.

Now consider any $t \in E(T(A \cap B), d_m) \subseteq E(TA, d_m) \cup E(TB, d_m)$. Without loss, we suppose that $t \in E(TA, d_m)$. On the one hand, $T(A \cap B) \subset TA \cap TB$ implies that $t \cdot d_m \leq t' \cdot d_m$ for all $t' \in E(TA \cap TB, d_m)$. On the other hand, as $TA \cap TB \subset TA$, it must be the case that $t \cdot d_m \geq t' \cdot d_m$ for all $t' \in E(TA \cap TB, d_m)$. Hence, overall we have $t \cdot d_m = t' \cdot d_m$ for all $t' \in E(TA \cap TB, d_m)$. As $t \in TA \cap TB$, we can conclude that $t \in E(TA \cap TB, d_m)$. \square

Proof of Theorem 9. For arbitrary direction $d_m \in \mathbb{R}^m$ the support function of the image of the intersection equals

$$S^{T(A \cap B)}(d_m) = \sup_{t \in T(A \cap B)} t \cdot d_m = \sup_{x \in A \cap B} x \cdot T^*(d_m) = S^{A \cap B}(T^*(d_m)),$$

where T^* is the adjoint operator. As $\text{image}(T^*) = \ker(T)^\perp$ we have $T^*(d_m) \in \ker(T)^\perp$. The support function for the intersection of sets having non-empty intersection of their relative interiors $\text{ri } A \cap \text{ri } B \neq \emptyset$ can be conveniently characterized by (see p. 145 in Rockafellar (1997))

$$S^{A \cap B}(T^*(d_m)) = \inf_{\substack{d' + d'' = T^*(d_m) \\ d', d'' \in \mathbb{R}^n}} (S^A(d') + S^B(d'')). \quad (\text{A.1})$$

Taking into account the condition of the theorem and that the set of support points is non-empty in any direction for compact sets we obtain

$$S^{A \cap B}(T^*(d_m)) = \inf_{\substack{d' + d'' = T^*(d_m) \\ d', d'' \in \mathbb{R}^n}} (S^A(d') + S^B(d'')) = \inf_{\substack{d' + d'' = T^*(d_m) \\ d', d'' \in \ker(T)^\perp}} (S^A(d') + S^B(d'')). \quad (\text{A.2})$$

As $d', d'' \in \ker(T)^\perp = \text{image}(T^*)$ there must exist $d'_m, d''_m \in \mathbb{R}^m$ such that $d' = T^*(d'_m)$, and $d'' = T^*(d''_m)$. Moreover, we must have $d'_m + d''_m = d_m$.⁷ Hence,

$$\begin{aligned} S^{A \cap B}(T^*(d_m)) &= \inf_{\substack{d'_m + d''_m = d_m \\ d'_m, d''_m \in \mathbb{R}^m}} (S^A(T^*(d'_m)) + S^B(T^*(d''_m))) \\ &= \inf_{\substack{d'_m + d''_m = d_m \\ d'_m, d''_m \in \mathbb{R}^m}} (S^{TA}(d'_m) + S^{TB}(d''_m)) = S^{TA \cap TB}(d_m). \end{aligned}$$

Overall, $S^{T(A \cap B)}(d_m) = S^{TA \cap TB}(d_m)$ for all directions $d_m \in \mathbb{R}^m$. Hence, $T(A \cap B) = TA \cap TB$.

(Only-if statement) To establish the necessity part, we assume that $T(A \cap B) = TA \cap TB$ and consider any direction $d \in \ker(T)^\perp$ and support point $u \in E(A \cap B, d)$. As $\ker(T)^\perp = \text{image}(T^*)$ there must exist $d_m \in \mathbb{R}^m$ such that $d = T^*(d_m)$. For this direction, we have

$$S^{TA \cap TB}(d_m) = \inf_{\substack{d'_m + d''_m = d_m \\ d'_m, d''_m \in \mathbb{R}^m}} (S^{TA}(d'_m) + S^{TB}(d''_m)) = \inf_{\substack{d'_m + d''_m = d_m \\ d'_m, d''_m \in \mathbb{R}^m}} (S^A(T^*(d'_m)) + S^B(T^*(d''_m))). \quad (\text{A.3})$$

For any d'_m, d''_m such that $d'_m + d''_m = d_m$, let $d', d'' \in \ker(T)^\perp$ and $d' = T^*(d'_m)$, $d'' = T^*(d''_m)$, $d' + d'' = T^*(d_m) = d$. As $T(A \cap B) = TA \cap TB$ there must exist d' and d'' such that

$$u \cdot d = S^{A \cap B}(T^*(d_m)) = S^{T(A \cap B)}(d_m) = S^{TA \cap TB}(d_m) = S^A(d') + S^B(d''),$$

where the last equality follows from Theorem 16.4 in Rockafellar (1997), which asserts that the infimum of (A.3) is achieved when the relative interiors of the two sets have a point in common. Also, as $u \in A \cap B$, we have $u \cdot d' \leq S^A(d')$ and $u \cdot d'' \leq S^B(d'')$. As a result, we must have $u \cdot d' = S^A(d')$, and $u \cdot d'' = S^B(d'')$. In other words, $u \in E(A, d') \cap E(B, d'')$, where $d', d'' \in \ker(T)^\perp$ and $d' + d'' = T^*(d_m)$. As the choice of d_m is arbitrary and $\text{image}(T^*) = \ker(T)^\perp$ the only-if statement follows. \square

⁷To see that $d'_m + d''_m \neq d_m$ is not possible, denote $a_m = d'_m + d''_m - d_m \in \text{image}(T)$. By construction, $T^*(a_m) = 0$, and thus $a_m \in \ker(T^*) = \text{image}(T)^\perp$. Hence, we have $a_m \in \text{image}(T) \cap \text{image}(T)^\perp$, which implies $a_m = 0$.

Proof of Theorem 10. The proof of the sufficient part follows from the proof of the sufficient part of Theorem 9. Let us now establish the necessary part. Assume that $T(A \cap B) = TA \cap TB$. This implies that for any $d_m \in \mathbb{R}^m$ we have $S^{T(A \cap B)}(d_m) = S^{TA \cap TB}(d_m)$. We know that

$$\begin{aligned} S^{TA \cap TB}(d_m) &= \inf_{\substack{d'_m + d''_m = d_m \\ d'_m, d''_m \in \mathbb{R}^m}} (S^{TA}(d'_m) + S^TB(d''_m)) \\ &= \inf_{\substack{d'_m + d''_m = d_m \\ d'_m, d''_m \in \mathbb{R}^m}} (S^A(T^*d'_m) + S^B(T^*d''_m)). \end{aligned}$$

As $\text{image}(T^*) = \ker(T)^\perp$, there must exist $d', d'' \in \ker(T)^\perp$ such that $d' = T^*d'_m$, $d'' = T^*d''_m$. Similar to the proof of Theorem 9 (see footnote 3) we establish that sets $\{d', d'' \in \ker(T)^\perp \mid d' + d'' = T^*d_m\}$ and $\{d', d'' \in \ker(T)^\perp \mid d' = T^*d'_m, d'' = T^*d''_m, d'_m + d''_m = d_m\}$ coincide. Therefore,

$$S^{TA \cap TB}(d_m) = \inf_{\substack{d' + d'' = T^*d_m \\ d', d'' \in \ker(T)^\perp}} (S^A(d') + S^B(d')).$$

At the same time, we have

$$S^{T(A \cap B)}(d_m) = S^{A \cap B}(T^*d_m) = \inf_{\substack{d' + d'' = T^*d_m \\ d', d'' \in \mathbb{R}^n}} (S^A(d') + S^B(d')).$$

Finally, as $\text{image}(T^*) = \ker(T)^\perp$, we can conclude that for any $d \in \ker(T)^\perp$

$$\inf_{\substack{d' + d'' = d \\ d', d'' \in \mathbb{R}^n}} (S^A(d') + S^B(d'')) = \inf_{\substack{d' + d'' = d \\ d', d'' \in \ker(T)^\perp}} (S^A(d') + S^B(d'')). \quad \square$$

References

- Aumann, R. J., and Hart, S. (1986). Bi-convexity and bi-martingales. *Israel Journal of Mathematics*, 54(2), 159-180.
- Axler, S. J. (1997). *Linear Algebra Done Right*. New York: Springer.
- Gershkov, A., Goeree, J. K., Kushnir, A., Moldovanu, B., and Shi, X. (2013). On the Equivalence of Bayesian and Dominant Strategy Implementation. *Econometrica*, 81, 197-220.
- Goeree, J. K. and Kushnir, A. (2017). A Geometric Approach to Mechanism Design. Working Paper, University of New South Wales and Tepper School of Business, Carnegie Mellon University.
- Hiriart-Urruty, J. B. and Lemaréchal, C. (2012). *Fundamentals of Convex Analysis*. Springer Science & Business Media.
- Laffont, J-J. and Maskin, E. (1980). A Differential Approach to Dominant Strategy Mechanisms. *Econometrica*, 48, 1507-1520.
- Manelli, A. M. and Vincent, D. R. (2010). Bayesian and Dominant-Strategy Implementation in the Independent Private Values Model. *Econometrica*, 78, 1905–1938.
- Milgrom, P. R. (2004). *Putting Auction Theory to Work*. Cambridge University Press.
- Myerson, R. (1979). Incentive Compatibility and the Bargaining Problem. *Econometrica* 47, 61-73.
- Rockafellar, R. T. (1997). *Convex Analysis*. Princeton University Press.
- Roth, A. E. (2008). What Have We Learned From Market Design?. *The Economic Journal*, 118(527), 285–310.