

Popescu, Dan; Ciocârlan-Chitucea, Alina; Steriu, Alexandra; State, Cristina

Article

Change Management – Condition of Organizational Sustainability in IT&C Small and Medium-Sized Enterprises

Amfiteatru Economic Journal

Provided in Cooperation with:

The Bucharest University of Economic Studies

Suggested Citation: Popescu, Dan; Ciocârlan-Chitucea, Alina; Steriu, Alexandra; State, Cristina (2012) : Change Management – Condition of Organizational Sustainability in IT&C Small and Medium-Sized Enterprises, Amfiteatru Economic Journal, ISSN 2247-9104, The Bucharest University of Economic Studies, Bucharest, Vol. 14, Iss. 32, pp. 333-348

This Version is available at:

<https://hdl.handle.net/10419/168758>

Standard-Nutzungsbedingungen:

Die Dokumente auf EconStor dürfen zu eigenen wissenschaftlichen Zwecken und zum Privatgebrauch gespeichert und kopiert werden.

Sie dürfen die Dokumente nicht für öffentliche oder kommerzielle Zwecke vervielfältigen, öffentlich ausstellen, öffentlich zugänglich machen, vertreiben oder anderweitig nutzen.

Sofern die Verfasser die Dokumente unter Open-Content-Lizenzen (insbesondere CC-Lizenzen) zur Verfügung gestellt haben sollten, gelten abweichend von diesen Nutzungsbedingungen die in der dort genannten Lizenz gewährten Nutzungsrechte.

Terms of use:

Documents in EconStor may be saved and copied for your personal and scholarly purposes.

You are not to copy documents for public or commercial purposes, to exhibit the documents publicly, to make them publicly available on the internet, or to distribute or otherwise use the documents in public.

If the documents have been made available under an Open Content Licence (especially Creative Commons Licences), you may exercise further usage rights as specified in the indicated licence.



<http://creativecommons.org/licenses/by/4.0/>

CHANGE MANAGEMENT – CONDITION OF ORGANIZATIONAL SUSTAINABILITY IN IT&C SMALL AND MEDIUM-SIZED ENTERPRISES

Dan Popescu^{1*}, Alina Ciocârlan-Chituca², Alexandra Steriu³ and Cristina State⁴

^{1) 2)3)4)} Academy of Economic Studies, Bucharest, Romania

Abstract

The present research aims to establish and outline strategies for promoting change in the context of organizational learning, in order to maintain deeply active and creative human resources, while capable of achieving economic sustainability. This is becoming more obvious now as the changes take place in a dynamic world where human resources are the only key factors able to provide the design and implementation of routine changes and procedures, in the present and not in the future.

Furthermore, to highlight strengths and weaknesses of approaches regarding the sustainability and organizational change, our topic of research was conducted as an empirical study on the IT&C Small and Medium-sized Enterprises (SMEs), especially in the context of sustainability tending to become even more a value of modern, dynamic and powerful organizations.

The main objective of the article is to outline some potential ways to implement the change management in the IT&C Romanian SMEs environment and their perception manner concerning the rationality and operationality of change, to ensure the viability and the organizational sustainability.

Keywords: sustainability, change management, organizational change, organizational performances, Small and Medium-Sized Enterprises (SMEs) in the Field of The Information Technology and Communications (IT&C)

JEL Classification: M3, M31, L81

Introduction

The contemporary society is marked by confrontation, identification, evaluation and action process (Paton, 2004, p. 39), a process called change. In these conditions, the necessity for permanent improvements in performances and continued creating of new opportunities is likely to cause and/or produce the change.

For the organization to survive, it is essential to implement successful change processes (Paton, 2004, p. 40; Senior, 2001, p. 47; Deutschman, 2007, p. 35). Basically, change is a natural and universal process of the world we live in and is never gone (Cohen and Kotter,

* Corresponding author, **Dan Popescu** – dan.popescu@man.ase.ro

2005, p. 87). Therefore, the change becomes necessary, inevitable and furthermore is a process of adaptation and evolutionary potential for each person, organization and / or society.

In an era of information and communication technology, organizational changes are imminent for the organizations survival playing an important role in their own adaptation to extremely rapid technological development (Turban and McLean, 2009, pp.38-39).

The experience shows that organizational change is associated with sustainability at macro level and durable development at micro level. In essence, the process of change targets society as a whole, organizations and people as functional units (Leca, 1999, p. 39) or, according to another approach, the person and only after, the group / organization (Nica, 2006, p. 2).

At the organizational level, change can be perceived not only as an opportunity, but also as a threat. Seen as an opportunity, the change is a chance for an organization to eliminate an unsatisfactory situation. When the current situation is generally satisfactory, the change can become a threat because it can endanger the privileged position which is intended to be maintained.

Change is related to modification occurred in goals, plans and structure, motivation and control systems (Kotter, 2006, pp. 89-90) and it has three vectors of action: competitive environment control, strengthening of human potential, continuous improvement processes.

The potential factors of the organizational change are internal, external, political, economic, technological and socio-cultural in their paramount concern with the environment. Here is the context in which organizational change is inconceivable without enterprise's sustainability. (Dinu, 2010, pp. 5-7; Dinu, 2011, pp. 6-7).

As a concept, sustainability has different meanings. Thus, some authors (Cândeia, 2011, p.2) believe that an organization is sustainable if it operates as so to protect the environment, often being called "green". In the view of other authors (Lubin and Esty, 2010, pp.9-10), the sustainability is proven by the social responsibility of the company, which must be manifested and sustained by socially responsible investment, that organization seeks to respond to complex performance criteria, including extra financial nature, criteria that relate to the environmental management and resolution of problems in the social sphere.

1. Objectives, hypotheses and research methodology

1.1 Objectives

The main objective of our applied research was to outline the implementation of change management in the IT&C Romanian SMEs environment and their perception manner concerning the changes rationality and operationality, to ensure the viability and the organizational sustainability.

We chose the approach of applied research to be performed by initiating organizational change at the managerial level, given the fact that the improvement opportunity in this direction has recently won, an increasing important role in SMEs (Barbu and Nedelea, 2005, p. 25) both as an academic subject and as an issue for empirical area. (Popescu, Chivu, Scarlat et al., 2010, pp. 49-50).

1.2 Research hypotheses

Main hypothesis: The perception manner of entrepreneurs / managers concerning the rationality and implementation of change management in IT& C SMEs influences direct and positive the organizational performance.

The three secondary hypotheses, relevant for the role played by the organizational change in obtaining sustainable economic performances are:

- Entrepreneurs / managers of SMEs do not adopt a consistent approach of change management based on the rationality, designing and implementation of some strategies in order to achieve change at the organizational level;
- Organizational change processes are initiated usually ad hoc, depending on current issues, without being based on coherent plans of action, which jeopardize the sustainability of IT&C SMEs;
- The approach of change management in IT&C SMEs is punctual and reactive, being determined, in most cases, by the specific character of certain projects in progress.

We decided that after testing the three hypotheses to build a specific model to include a constructive approach of change management in IT&C SMEs, the applicable approaches taken in the context of the economy based on knowledge and also economic and social sustainability.

In terms of design, the research was a combination of a random stratified survey with unequal probabilities (Isaic-Maniu, Mitruț and Voineagu, 2004, pp. 226-238) and a conducted half random survey (Filip, Spătaru and Mircea, 2002, pp. 178-184), which was imposed by organizational reasons regarding the restrictions and limitations of such research made by one person.

1.3 Research methodology

The methodology used was a logical consequence of the questions used in the research as a first step in choosing the quantitative / qualitative approach. For our study, the key question used was: To what extent, the way and the implementation degree of change management in SMEs operating in the IT&C sector, causes increased organizational, economic and financial performance?

We conducted the data collection phase with the organization phase and ongoing of interviews. To obtain the necessary research, we have chosen two modes of action, namely:

- activity on the field (personal administration of questionnaires to managers and / or entrepreneurs of organizations);
- sending questionnaires online or by mail, using the contact details of SME (we used the database of the National Council of Small and Medium Enterprises in Romania - CNIPMMR).

Regarding the statistical survey, we have chosen SMEs which have been the sample's survey respecting the principle of rational choice, communities being structured in typical groups, according to a predetermined criteria.

In order to obtain recoil border between quality and quantity and also improvement of the link between these areas, a considerable potential was provided by turning to lexical analysis technique, through which we could accomplish quantification of qualitative, trend aimed to improve decisions in the areas defined through quality standards, by obtaining objective analysis. With this purpose, we have included in the questionnaire, *open questions* whose answers have been processed along with other existing texts, mainly those concerning organizational change and its management and leadership.

Sample representativeness was ensured mainly not so much by its size, as the following characteristics non-alternative on which was determined: the main activity and number of employees. Furthermore, to compensate for possible errors, we applied the methods to improve further stratification by successive recalibration.

The interviews had well defined goals as a starting point, which were both theoretical and pragmatic.

Some of the theoretical objectives were: conducting interviews on change-performance approach that would complement the main research tool: the questionnaire, highlighting managers' opinion on the changing attitudes of the organization employees, identifying aspects of human motivation for work.

As pragmatic objectives, we pursued: identifying the awareness of respondents, the concept of change management, identifying the forces which causes greater resistance to change from managers (who initiates the change) and employees (those who are subject of change), making recommendations for managers in using elements that determine the change in the organization.

At the base of the interview's design was the hypothesis under which the employees capacity to notice, to resist or to facilitate the changes in the work processes, is vital for the organizational performance.

The questionnaire included closed questions, with general character, allowing immediate response formulation. The second part of the questionnaire was limited to issues related to SME profitability of IT&C area and their economic performance, and the third, the change-performance relationship. Research hypotheses, such as the conclusions, are also in close interdependence with the responses of second and third parts of the survey.

First of all, we obtained the validation of questionnaire based on core values of the survey results. We sent the original version of the questionnaire, the pilot study by SMEs in Bucharest, to receive feedback on the accuracy of questions. After completing the questionnaire, we asked respondents feedback. A revised version of research instruments was sent to all pre-established SMEs in the sample.

When we made the survey statistics, we have established the general collectivity researched as being the ensemble of active SMEs in the IT & C area based in Romania, which compiled and submitted the balance in 2010 in evidence and national statistics for Romania.

We conducted the survey on a sample of 198 IT & C SMEs from Romania. Details of the territorial distribution of SMEs investigated sample can be found in table no. 1:

Table no. 1: Territorial structure of the sample

Crt. No.	County	Number of organizations (ni)	Percentage of total
1.	Alba	2	1%
2.	Bihor	1	0,5%
3.	Braşov	14	7%
4.	Bucureşti	160	81%
5.	Cluj	2	1%
6.	Dolj	1	0,5%
7.	Constanţa	11	5,5%
8.	Hunedoara	1	0,5%
9.	Iaşi	1	0,5%
10.	Prahova	2	1%
11.	Timiş	2	1%
12.	Tulcea	1	0,5%
	TOTAL	198	100 %

Details regarding the sample structure by size classes are given in table no. 2:

Table no. 2: Sample distribution by size classes

Crt. No.	Size classes	Number of organizations (ni)	Percentage (%)
1.	1 - 9 employees	78	39,4%
2.	10 - 49 employees	102	51,5%
3.	50 - 249 employees	18	9,1%
	TOTAL	198	100 %

Sample distribution according to main activity is as presented in table no. 3:

Table no. 3: Sample distribution by main activity

Crt. No.	Main activity	Number of organizations (ni)	Percentage (%)
1.	IT products (hardware, software, services)	121	61,1%
2.	telecommunication products	66	33,3%
3.	electronical products	11	5,6%
	TOTAL	198	100 %

Despite the prevalence of IT & C products that are core business for most of the SMEs surveyed (61.1%), we find an adequate representation of other branches of the IT & C, intended to provide heterogeneity to the areas of activity studied in the sample.

Statistical instruments

Data obtained were analyzed using Statistical Packages for Social Scientists (SPSS) 16.0. Given the large amount of information, the results are summarized.

Since the main indicators of central tendency are arithmetic mean, standard deviation and coefficient of variation, plus auxiliary statistical indicators, we determined the weighted average (\bar{x}), respecting the imposed frequency distribution by variants of the questionnaire response.

$$\bar{x} = \frac{n_1v_1 + n_2v_2 + \dots + n_nv_n}{n} = \frac{1}{n} \sum_{i=1}^n n_i v_i \tag{1}$$

Since data obtained from interviews differ significantly, depending on the criteria for classification of SMEs, we calculated partial averages for each type of collectivity. Partial averages (also called moving averages) were used in the situation of large fluctuations in the string values, for which the trend is hard to estimate. The calculation is mediating a number m of attached values:

$$\overline{x_{glis,m}} = \frac{x_{i-2} + x_{i-1} + x_i + x_{i+1} + x_{i+2}}{m} \tag{2}$$

Standard deviation (σ) is calculated as the mean square of elements at their main value:

$$\sigma = \sqrt{\frac{\sum(x_i - \bar{x})^2}{n}} \tag{3}$$

This indicator is relevant by raising the square deviation. We gave more importance to the absolute deviation affecting in large extent, the degree of variation in the analyzed variables.

Coefficient of variation (v) is calculated as the ratio between standard deviation and arithmetic mean, values of this indicator being subunit:

$$v = \frac{\sigma}{x} \cdot 100 \tag{4}$$

The closer value of v is to zero, the lower the variation is getting. Thus, the collectivity is homogeneous, and the arithmetic mean has a high degree of representativeness. The greater the value of v is, the more intense the variation is getting. Consequently, the collectivity is heterogeneous, and the arithmetic mean has a lower significance level.

2. Research results

We will present, further, the most important research results, focusing on basic characteristics and detailed secondary correlations (table no. 4).

Table no. 4: Statistical indicators correspondent to central tendency

<i>Standard error</i>	247
<i>Median</i>	45
<i>Modal value</i>	4
<i>Dispersion</i>	374,278
<i>Standard deviation</i>	4082
<i>Asymmetry (Pearson)</i>	11
<i>Arching (Beta)</i>	46338

<i>Amplitude</i>	110
<i>Minimum</i>	3
<i>Maximum</i>	150000
<i>Coefficient of variation</i>	34

Source: authors processing

The high amplitude (110) is correlated with high levels of dispersion (374,278) and standard deviation. To reflect the SMEs in the level of turnover, we made a series of unequal intervals of small values initially reduced length intervals and subsequently increased, the upper axis values. In the interpretation of primary data obtained by the questionnaire, bivariate analysis assumed considering the variables involved, in pairs. Given the research hypotheses, and the objectives of the study, we considered the following pairs of variables (table no.5):

- change management forms used by managers within the organization, in correspondence with the frequency of application;
- change management forms used by managers within the organization, in correspondence with the intensity of application.

Table no. 5: Distribution of change management forms, by the frequency of application

Crt. no.	Change management forms according to frequency of application	Frequency of application			Ascending cumulative frequency of application		
		Minimum	Medium	Maximum	Minimum	Medium	Maximum
1.	<i>Level of the received remuneration by the employees</i>	3.17	4.14	4.29	4.00	4.00	4.00
2.	<i>Payment of extra hours</i>	4.00	3.71	3.29	3.67	3.63	4.00
3.	<i>Awards, bonuses and other financial benefits</i>	3.83	3.57	3.29	4.50	3.38	3.71
4.	<i>Ensuring the correspondence between skills, qualities and skills of employees and job requirements</i>	3.33	4.29	3.86	4.17	4.00	2.71
5.	<i>Creating and ensuring good working conditions (job adapting to humans)</i>	4.17	3.86	4.14	4.33	3.00	3.86
6.	<i>The existence of a pleasant working environment</i>	4.00	3.57	3.14	4.83	3.63	3.29
7.	<i>The existence of cooperation and collaboration at work</i>	3.67	3.86	4.57	3.83	2.50	3.29
8.	<i>Opportunity to advance, to be promoted</i>	3.83	3.57	3.43	3.67	3.00	3.43
9.	<i>Opportunity to express their opinions and creativity at work</i>	4.17	3.86	2.86	5.00	4.25	4.71
10.	<i>Obtaining feedback by employees, from the beneficiaries of their work (superiors, clients)</i>	3.00	3.43	3.14	3.50	3.63	3.29
11.	<i>A normal work-rest ratio (working less than 40 hours per week)</i>	3.17	3.86	3.71	3.83	3.63	4.00
12.	<i>Management effort to reduce as much the stress from work</i>	3.67	3.86	4.14	4.17	4.00	4.43

Source: authors processing

Testing Hypothesis 1 from statistical processing of data:

Hypothesis 1: Entrepreneurs / managers of SMEs do not adopt a consistent approach to change management based on the design, development and implementation of strategies in order to achieve organizational change.

In figure no. 1 we presented the absolute frequencies, highlighting the high dispersion and low frequencies, to the extreme right of values.

Absolute frequency histogram for implementing change management shows a strong scattering for the values of change forms frequencies, demonstrating their heterogeneity.

Histogram chart type shows a high level of:

- economic forms of change (the maximum is reached between 5-6);
- level of changing shape intensity, which decreases as the number of constantly type approaches increases.

We concluded that between forms of change and organizational performance is a direct, positive relationship.

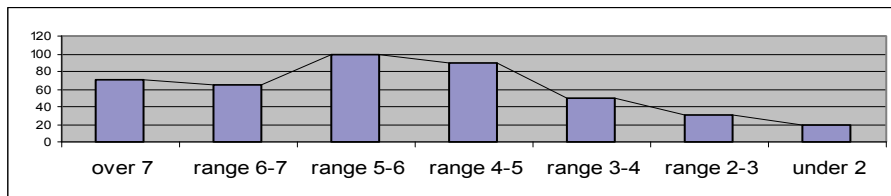

Figure no. 1: Absolute frequency histogram for implementing change management

Source: results obtained by authors from statistical data processing

Testing Hypothesis 2 after statistical processing of data:

Hypothesis 2: Organizational change processes are initiated ad-hoc, depending on current issues, without coherent plans of action based on.

In figure no. 2 we have presented the absolute frequencies, highlighting the high dispersion and low frequencies, to the extreme right of values. Absolute frequency histogram was capable of demonstrating strong scattering processes of organizational change frequency values, which demonstrates their heterogeneity.

Histogram chart type shows a high level of:

- organizational change processes (the maximum is reached in the range 4-5);
- intensity level of the process that increases while applying change management.

Hypothesis testing revealed that between the processes of organizational change and performance organization is a direct, positive relationship.

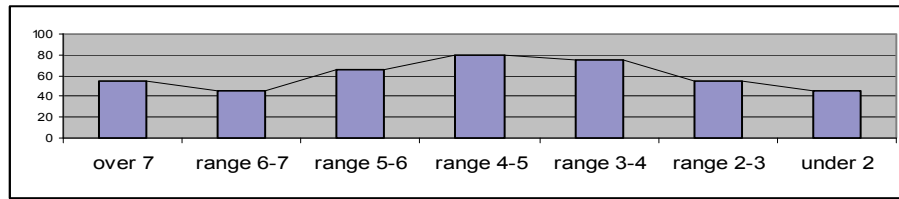

Figure no. 2: Absolute frequency histogram for implementing organizational change processes

Source: results obtained by authors from statistical data processing

Testing Hypothesis 3 from statistical processing of data:

Hypothesis 3: Addressing change management in SMEs is both punctual and reactive, being determined, often, by the specific of certain projects in progress

In figure no. 3 we present absolute frequencies, highlighting the high dispersion and low frequencies to the far right of the values, as when testing the first two hypotheses.

Absolute frequency histogram shows again strong scattering for the values of change management frequencies, demonstrating its heterogeneity.

Histogram chart type shows a high level of:

- application of change management (maximum value is reached within 5-6);
- intensity level of constant change management application, which decreases as the number of forms of change increases.

We found that between the existence of a pleasant working environment, cooperation and collaboration in work and organization performance is a direct, positive relationship.

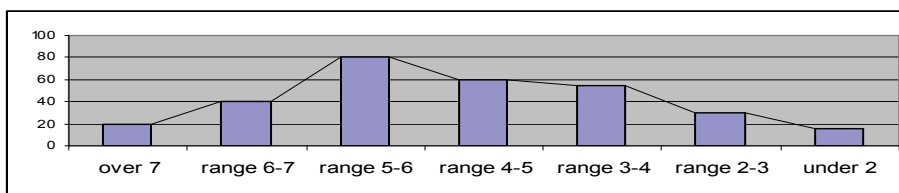

Figure no. 3: Absolute frequency histogram for implementing change management

Source: results obtained by authors from statistical data processing

Testing the main hypothesis: statistical regression and the method of least squares:

The main hypothesis: The perception of entrepreneurs / managers on the rationality and implementation of change management in SMEs in the IT & C area influence, direct and positive organizational performance.

In order to apply *regression*, the data series were noted as follows:

Y = economic and financial performance achieved by the organization

X = properly, consistently and at an appropriate intensity application of change management

Following the introduction of data series in the E-Views, by importing from Excel, we defined Aplicatia1.wf file that contains variables Y, X, c (coefficients vector) and resid (residues vector).

Simple regression model that we propose in this application is:

$$Y = \alpha + \beta * X + \varepsilon$$

Next, we determined the nature of the two variables (X and Y), variables that compose the regression equation and are necessary for estimation of regression models. Data from series are expressed in real terms. We analyzed descriptive data series and, following a parameter estimation of the first regression model using a number of 35 iterations, we obtained the following values of coefficients α and β :

$$Y = 438.1614 + 1.375421 * X$$

(91.56818) (0.010994)

Positive sign of regression coefficient (1.375421) shows a direct link between the application of change management and organizational performance by managers and entrepreneurs. Its value must be interpreted as follows: increasing with a unit the intensity of change management application, the attached financial and economic performance of the organization increases, on average, with 1.375421 units. Constant term has a value of 438.1614 and expresses the value of gross domestic product, where private consumption would be zero (table no. 6):

**Table no. 6: The results obtained from running E-Views program:
Simple regression model**

Dependent Variable: Y				
Method: Least Squares				
Sample: 2000:1 2008:3				
Included observations: 35				
Variable	Coefficient	Std. Error	t-Statistic	Prob.
C	438.1614	91.56818	4.785084	0.0000
X	1.375421	0.010994	125.1112	0.0000
R-squared	0.997896	Mean dependent var		11792.40
Adjusted R-squared	0.997832	S.D. dependent var		1548.956
S.E. of regression	72.11493	Akaike info criterion		11.44984
Sum squared resid	171618.6	Schwarz criterion		11.53872
Log likelihood	-198.3723	F-statistic		15652.80
Durbin-Watson stat	0.542041	Prob(F-statistic)		0.000000

Source: results obtained by the authors from data processing in E-Views

In order to study the property of heteroskedasticity we used White statistics, and for errors autocorrelation we used Durbin-Watson statistics (table no. 7):

Table no. 7: The results obtained from running E-Views program: Durbin-Watson test

White Heteroskedasticity Test:			
F-statistic	3.972685	Probability	0.028770
Obs*R-squared	6.961706	Probability	0.030781

Source: results obtained by the authors from data processing in E-Views

Because Fischer statistics calculated value does not have the marginal null level, hypothesis can not be accepted, namely that series residues is heteroskedastic. Durbin-Watson statistics has the value 0.542041, which leads to the conclusion that the error series is autocorrelated, which confirms the main hypothesis.

We performed a second main hypothesis testing using the methods of least squares (OLS) results are presented in table no. 8:

**Table no. 8: The results obtained from running E-Views program:
The method of least squares**

Dependent Variable: Y				
Method: Least Squares				
Sample: 2000:1 2008:3				
Included observations: 35				
Variable	Coefficient	Std. Error	t-Statistic	Prob.
X	1.375421	0.010994	125.1112	0.0000
C	438.1614	91.56818	4.785084	0.0000
R-squared	0.997896	Mean dependent var		11792.40
Adjusted R-squared	0.997832	S.D. dependent var		1548.956
S.E. of regression	72.11493	Akaike info criterion		11.44984
Sum squared resid	171618.6	Schwarz criterion		11.53872
Log likelihood	-198.3723	F-statistic		15652.80
Durbin-Watson stat	0.542041	Prob(F-statistic)		0.000000

Source: results obtained by the authors from data processing in E-Views

The results were interpreted econometric, as follows:

Results testing

To check the significance of estimators obtained by applying *simple linear regression* model, we applied the t Test:

- For the free term α we have:

$$H_0 : \alpha = 0$$

$$H_1 : \alpha \neq 0$$

From Table no. 8 result estimations, in OLS sense, namely: the estimated value of the parameter α is 438.1614, the standard deviation of 91.56818, and the test statistic value is 4.785084. Since the marginal level of significance (p-value) is less than 0.05 (in our case, is 0.0000), we will reject the null hypothesis, under which free term is zero. In conclusion, the free term is significantly different from zero.

- For the β term we have :

$$H_0 : \beta = 0$$

$$H_1 : \beta \neq 0$$

From the summary table we concluded that the estimated value for β parameter is 1.375421, with standard deviation of 0.010994 in OLS sense, and test statistics value is 125.1112. As marginal significance level is very close to zero, we accept the alternative hypothesis, which ensure us that the parameter β is significantly different from zero. By checking the significance of estimators obtained by OLS, results that they are significantly different from zero.

Analysis of variance for simple regression model

In simple linear regression model we expressed linearly dependent variable Y and consequently, we assessed whether variations in the variable X affects +s values change. For values of independent variable X, we can determine the deviation from the average range. Or, otherwise stated, we can determine the total variation corresponding to variable Y. Using total variance decomposition rule, we get:

Total variance = variance explained by the X values + variance unexplained by the model

Taking into account the appropriate degrees of freedom, we applied the F statistic (Fisher-Snedecor). For the regression model considered, it appears that value of F statistics is 15652.80 and marginal significance level is very low (0.000000), which leads to the conclusion that $\beta \neq 0$.

A qualitative indicator of the regression model is the coefficient of determination (R-squared). Its values close to 1 means that the variable Y variations are explained by variations in the variable X. As the value of the determination coefficient is 0.997896, results that the model does not adjust well the sample data.

As a result of estimation parameters, the mathematical model describing the relationship between the two indicators analyzed can be represented as:

$$Y = 438.1614 + 1.375421 * X$$

(91.56818) (0.010994)

Based on the results we found that between the variables Y and X there is a significant positive linear dependence, and also that the regression slope is positive and significantly different from zero.

Correlation between the two indicators is justified by defining the simple regression model, while econometric analyzes performed on these models shows that indicator values fall within the ranges for which is confirmed the link between the two variables.

In our opinion, calling for the implementation of change management strategies is, in most cases, punctual and retroactive, not proactive and systemic.

Finally, we propose a potential model for achieving organizational change in SMEs from IT&C area, as those given in figure no. 4.

Figure no. 4: Model for achieving organizational change in SMEs from the IT & C area

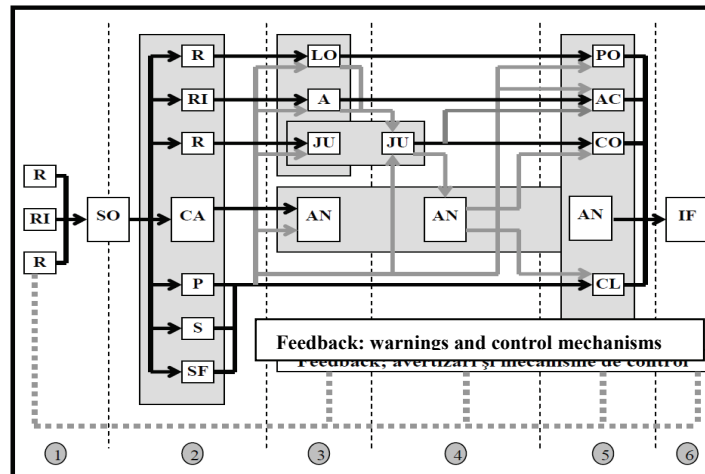

where:

RG - relationships with the government;
RI - relationships with investors;
RM - relationships with mass-media;
SO - strategy of the organization;
CA - communications with employees;
P - publicity;
S - sponsorships;
SF - structure of the company;
LO - people engaged in lobbying;

A - analysts;
JU - journalists;
AN - employees;
PO - politicians;
AC - shareholders;
CO - competitors;
CL - clients;
IF - image of the company.

Phase 1 shows that change is an essential condition for the sustainability of the organization, change management being an integral part of strategic management and, thus, causing strategy and viability of the company.

The following steps will demonstrate the added value that this integration it provides, as follows:

Phase 2 illustrates how organizational strategy must include and be adapted to change strategy. In this phase it is also demonstrated the importance of human resources and leadership in this process.

Phase 3 opens a series of three verifications (checkings) and signals of difficult situations. In case of direct contact, change management specialists can check: if employees and / or intermediate communities understand organizational strategy or understood strategy is implemented. In both cases, change management may enter into strategic management feedback process containing this information.

Phase 4 analyzes the key positions in the communities of employees and journalists. In convergent communities, in particular, these positions are occupied by opinion leaders. While in Phase 3, the feedback was direct and personal at this stage it becomes more general and empirical. The selection process and the one of monitoring the news / comments in the press can be very useful leadership. In this context, in-house research studies can be used for employees, etc.

Phase 5 aims to target all communities and provide a new feedback system. Finally, their points of view and behaviours determine their company's image, through culture, identity, perception of the market and / or needs and / or requests of customers.

Finally, in phase 6 possibility of verifying the results, while the organizational strategy and is reflected in and of the company's image. It is clear that convergence of channels can cause a high speed process.

Conclusions

Organizational change and its effective and efficient management are prerequisites to the viability and organizational sustainability.

Here is the context in which at organizational level, management is faced with new challenges where their resolution shapes the very future of each company.

Our study has shown that entrepreneurs / managers of Romanian SMEs IT & C area has not adopted a consistent approach to change management based on the rationality, developing and implementation of strategies to achieve organizational change.

At the same time, we found that organizational change processes are initiated, usually ad hoc, depending on current issues, without being based on coherent plans of action, which endanger the sustainability of IT & C SMEs.

The study results also revealed that although the mode of perception on the rationality and implementation of change management in SMEs from the IT & C area influence, direct and positive performance of the organization and, hence, organizational sustainability, calling strategies for implementing change management is in most cases, punctual and retroactive, not proactive and systemic.

Our science approach has been completed by proposing a model of organizational change in SMEs from IT&C area, research being continued, in order to check the usefulness of its applicability, so that, based on knowledge, implementing change can ensure the viability and organizational sustainability as values of any modern, dynamic and powerful organization.

References

- Andrei, T. and Bourbonnais, R., 2008. *Econometrie*. Bucharest: Economică Publishing.
- Andrei, T., Stancu, S., Iacob, A.I. and Tuşa E., 2008. *Introducere în econometrie utilizând Eviews*. Bucharest: Economică Publishing.
- Barbu, P.G. and Nedelea, A., 2005. Holiday Attachment: the Construct and its Measurement. *Amfiteatru Economic*, VII(18), pp. 24-33.
- Bălan, C. and Ioniță, D., 2011. Exploratory Research on the Organizational Learning in Small Enterprises and Implications for the Economic Higher Education. *Amfiteatru Economic*, XIII(30), pp. 366-383.
- Chiot, D., 2002. *How Societies Change*. 3rd ed. New York: Pine Forge Press.
- Chivu, I. et al., 2010. Human resources development within Romanian small and medium sized enterprises - in a knowledge-based economy. *Metalurgia Internațional*, XV(7), pp. 48-52.
- Deutschman, A., 2007. *Change or Die: The Three Keys to Change at Work and in Life*. New York: Harper Business.
- Dinu, V., 2010. Commercial activity and the sustainable development. *Amfiteatru Economic*, XI(27), pp. 5-7.
- Dinu, V., 2011. Corporate Social Responsibility – Opportunity for Reconciliation between Economical Interests and Social and Environmental Interests. *Amfiteatru Economic*, XIII(29), pp. 6-7.
- Filip, A. (coord.), Spătaru, S. and Mircea, I., 2002. *Teoria probabilităților. Statistică matematică. Matematici financiare*. Bucharest: A.S.E. Publishing.
- Green, M., 2007. *Change Management Masterclass: A Step by Step Guide to Successful Change Management*. London: Kogan Pages.
- Holban (Oncioiu), I., 2010. Business, Ethics and The Environment: Imagining A Sustainable Future. *Amfiteatru Economic*, XI(27), pp. 254-256.
- Isaic-Maniu, A., Mitruț, C. and Voineagu, V., 2004. *Statistică*. Bucharest: Universitară Publishing.
- Kotter, J., 1996. *Leading Changes*. New York: Harvard Business Press.
- Kotter, J., 2005. *The Heart of Change Field Guide: Tools and Tactics for Leading Change in our Organization*. New York: Harvard Business Press.
- Kotter, J., 2006. *Our Iceberg Is Melting: Changing and Succeeding Under Any Conditions*. New York: St. Martin's Press.
- Leca, A., 1997. *Principii de management energetic*. Bucharest: Tehnică Publishing.
- Lubin, A.-D. and Esty, D.C., 2010. The Sustainability Imperative. *Harvard Business Review*, 38/May, pp. 39-43.
- Nica, P., 2006, Schimbarea organizațională continuă și organizația care învață. *Revista de Marketing și Comunicare în Afaceri*, [online] Available at: <www.markmedia.ro/2006> [Accessed 6 May 2011].

Olaru, M., Dinu, V. et al., 2010. Responsible Commercial Activity of SMEs and Specific Values of Sustainable Development in Terms of the European Excellence Model. *Amfiteatru Economic*, XI(27), pp. 10-26.

Paton, A., 2004. *Save The Beloved Country*. 3rd American ed. New York: Pocket Books.

Popescu, D. and Chivu, I., 2008. *Dezvoltarea abilităților de comunicare și negociere*. Bucharest: Ed. Luceafărul.

Rățiu-Suciu, C. (coord.), Luban, F., Hîncu, D. and Ene, N. 2002. *Modelarea economică aplicată*. Bucharest: Economică Publishing.

Senior, B., 2001. *Organizational Change*. New York: Prentice Hall.

Turban, E. and McLean, E., 1999. *Information technology for management: making connections for strategic advantage*. New York: John Wiley & Sons.

Turban, E. and Yan, W., 2009. *Work, Happiness and Unhappiness: Journal of Positive Psychology*, New York: Book Review of P. Warr.

Vărzaru, M. and Jolivet, E., 2011. Towards a Model of Designing an Organizational Structure in a Knowledge Based Society. *Amfiteatru Economic*, XIII(30), pp. 620-631.