

Krivonozhko, Vladimir W.; Førsvund, Finn R.; Lychev, Andrey V.

Working Paper

Smoothing the frontier in the DEA models

Memorandum, No. 11/2016

Provided in Cooperation with:

Department of Economics, University of Oslo

Suggested Citation: Krivonozhko, Vladimir W.; Førsvund, Finn R.; Lychev, Andrey V. (2016) : Smoothing the frontier in the DEA models, Memorandum, No. 11/2016, University of Oslo, Department of Economics, Oslo

This Version is available at:

<https://hdl.handle.net/10419/165954>

Standard-Nutzungsbedingungen:

Die Dokumente auf EconStor dürfen zu eigenen wissenschaftlichen Zwecken und zum Privatgebrauch gespeichert und kopiert werden.

Sie dürfen die Dokumente nicht für öffentliche oder kommerzielle Zwecke vervielfältigen, öffentlich ausstellen, öffentlich zugänglich machen, vertreiben oder anderweitig nutzen.

Sofern die Verfasser die Dokumente unter Open-Content-Lizenzen (insbesondere CC-Lizenzen) zur Verfügung gestellt haben sollten, gelten abweichend von diesen Nutzungsbedingungen die in der dort genannten Lizenz gewährten Nutzungsrechte.

Terms of use:

Documents in EconStor may be saved and copied for your personal and scholarly purposes.

You are not to copy documents for public or commercial purposes, to exhibit the documents publicly, to make them publicly available on the internet, or to distribute or otherwise use the documents in public.

If the documents have been made available under an Open Content Licence (especially Creative Commons Licences), you may exercise further usage rights as specified in the indicated licence.

MEMORANDUM

No 11/2016

Smoothing the frontier in the DEA Models

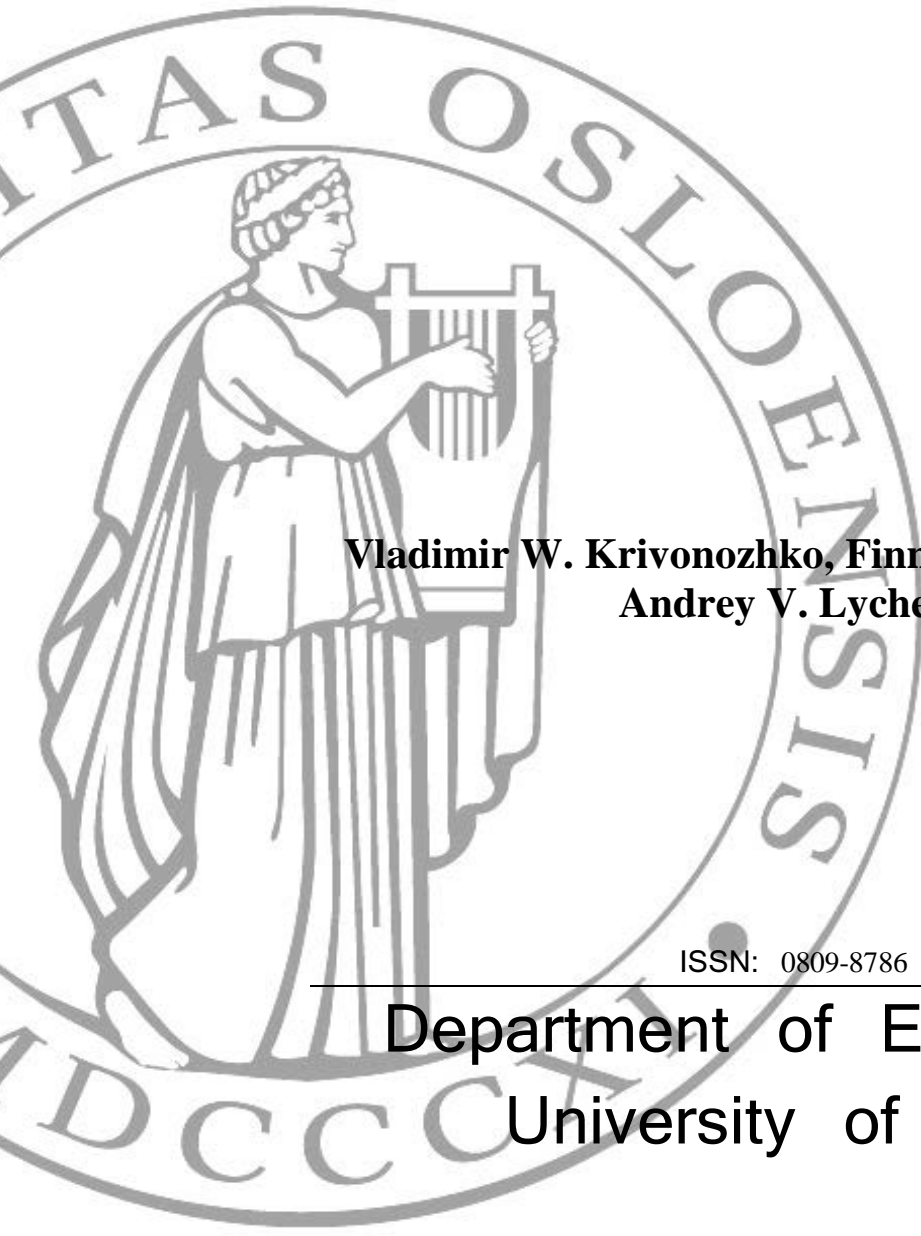
The seal of the University of Oslo is a circular emblem. It features a central figure of a woman in classical attire, holding a lyre. The text 'UNIVERSITAS OSLOENSIS' is inscribed around the top inner edge of the circle, and 'MDCCCXXXII' is at the bottom. The seal is rendered in a light gray tone.

**Vladimir W. Krivonozhko, Finn R. Førsund and
Andrey V. Lychev**

ISSN: 0809-8786

Department of Economics
University of Oslo

This series is published by the
University of Oslo
Department of Economics

P. O.Box 1095 Blindern
N-0317 OSLO Norway
Telephone: + 47 22855127
Fax: + 47 22855035
Internet: <http://www.sv.uio.no/econ>
e-mail: econdep@econ.uio.no

In co-operation with
**The Frisch Centre for Economic
Research**

Gaustadalleén 21
N-0371 OSLO Norway
Telephone: +47 22 95 88 20
Fax: +47 22 95 88 25
Internet: <http://www.frisch.uio.no>
e-mail: frisch@frisch.uio.no

Last 10 Memoranda

No 10/16	Finn R. Førsund <i>Pollution Modelling and Multiple-Output Production Theory*</i>
No 09/16	Frikk Nesje and Geir B. Asheim <i>Intergenerational altruism: A solution to the climate problem?*</i>
No 08/16	Michael Hoel <i>Optimal control theory with applications to resource and environmental economics</i>
No 07/16	Geir B. Asheim <i>Sustainable growth</i>
No 06/16	Arnaldur Sölvi Kristjánsson <i>Optimal Taxation with Endogenous Return to Capital</i>
No 05/16	Øystein Kravdal <i>Expected and unexpected consequences of childbearing – a methodologically and politically important distinction that is overlooked</i>
No 04/16	Dag Fjeld Edvardsen, Finn R. Førsund and Sverre A. C. Kittelsen <i>Productivity Development of Norwegian Institutions of Higher Education 2004 – 2013</i>
No 03/16	Finn R. Førsund <i>Multi-equation modelling of Desirable and Undesirable Outputs Satisfying the Material Balance</i>
No 02/16	Ingrid Hjort <i>Potential Climate Risks in Financial Markets: Report from a workshop, January 20, 2016</i>
No 01/16	Ingrid Hjort <i>Potential Climate Risks in Financial Markets: A Literature Overview</i>

Previous issues of the memo-series are available in a PDF® format at:
<http://www.sv.uio.no/econ/english/research/unpublished-works/working-papers/>

SMOOTHING THE FRONTIER IN THE DEA MODELS

by

Vladimir E. Krivonozhko,

National University of Science and Technology «MISiS», Moscow, Russia

e-mail: Krivonozhko@gmail.com

Finn R. Førsund,

Department of Economics, University of Oslo, Oslo, Norway

Address: Department of Economics, Box 1095 University of Oslo

0317 Blindern Norway, Telephone +47 22855132, Fax: +4722855035

e-mail: f.r.forsund@econ.uio.no

and

Andrey V. Lychev

National University of Science and Technology «MISiS», Moscow, Russia

e-mail: lychev@misis.ru

Abstract: Some inadequate results may appear in the DEA models as in any other mathematical model. In the DEA scientific literature several methods were proposed to deal with these difficulties. In our previous paper, we introduced the notion of terminal units. It was also substantiated that only terminal units form necessary and sufficient sets of units for smoothing the frontier. Moreover, some relationships were established between terminal units and other sets of units that were proposed for improving the frontier. In this paper we develop a general algorithm for smoothing the frontier. The construction of algorithm is based on the notion of terminal units. Our theoretical results are verified by computational results using real-life data sets and also confirmed by graphical examples.

JEL classification: C44, C61, D24

Keywords: Data Envelopment Analysis (DEA); Terminal units; Anchor units; Exterior units

Introduction

The DEA models like any other mathematical model may produce inadequate results when they apply to the real-life problems. In the DEA scientific literature several methods were proposed to deal with such difficulties. Already Farrell (1957) introduced artificial observations in the primal space of inputs and outputs in order to secure convex isoquants.

Another way to improve the frontier is to insert restrictions on the dual variables. An elegant and subtle approach was developed in the DEA models, which was based on incorporating domination cones in the dual formulations of DEA models. A number of outstanding papers developed applications of domination cones to the DEA models (Charnes et al. 1989, 1990; Thompson et al. 1990, 1997; Yu et al. 1996; Brockett et al. 1997; Wei et al. 2008). Cones are usually inserted in the dual space of multipliers. However, it may be difficult for a decision-maker to determine cones in the space of inputs and outputs where a production possibility set is constructed (Cooper et al. 2007). This is a reason why only two particular DEA models with cones are widely used in practice: the assurance region model and the cone-ratio model (Cooper et al. 2007). Various types of restrictions of the dual variables have been introduced in the DEA literature to improve the frontier, see Førsund (2013) for a critical review.

Podinovski (2007, 2015) developed an approach based on production trade-offs and weight restrictions in order to improve the frontier in the DEA models.

Thanassoulis and Allen (1998) and Allen and Thanassoulis (2004) took the idea of Farrell (without a reference) of dealing with the inadequate results in the DEA solution in the case of constant returns to scale and a single input by introducing artificial units. In their papers, the term anchor unit was defined for the observations that would be the basis for the artificial units.

Bougnol and Dulá (2009) introduced their definition of anchor units for the case of variable returns to scale and multiple inputs and outputs. They also elaborated algorithm for finding anchor units. However, their algorithm may generate units that are just efficient units in DEA models.

Thanassoulis et al. (2012) developed further the super-efficiency method for discovering anchor units in the BCC model; see Banker et al. (1984). At the same time, their method does not reveal all efficient units that may be the point of departure for improving the frontier in BCC models. Furthermore, their definition and their model produce different sets of anchor units. Moreover, their method of frontier improvement may turn initially efficient units into inefficient ones.

Edvardsen et al. (2008) developed an empirical method for determining "suspicious" units that are units that may generate inadequate results in the DEA models, they called them exterior units. At the same time, their methods cannot find all suspicious units.

Krivonozhko et al. (2009) showed that incorporation of domination cones in the dual space of multipliers in DEA models for smoothing the frontier is equivalent to incorporation of artificial units and rays in the primal space of inputs and outputs which makes the process of frontier improving more visible and understandable.

Krivonozhko et al. (2015a,b) defined the notion terminal units; it was substantiated that only terminal units give a necessary and sufficient set of units as a basis for smoothing the frontier in the DEA models. Moreover, some relationships between different sets of units (different sets of anchor units, exterior units and terminal units) that may cause inadequacies in the DEA models were established.

In this paper we developed a general algorithm for smoothing the frontier in the DEA models. We take the notion of terminal units as a point of departure for construction of algorithm. Our theoretical results are verified by computational experiments using real-life data sets and also illustrated by graphical examples.

Background

Consider a set of n observations of actual production units $(X_j, Y_j), j=1, \dots, n$, where the vector of outputs $Y_j = (y_{1j}, \dots, y_{rj}) \geq 0, j=1, \dots, n$, is produced from the vector of inputs $X_j = (x_{1j}, \dots, x_{mj}) \geq 0$. The production possibility set T is the set $\{(X, Y) \mid \text{the outputs } Y \geq 0 \text{ can be produced from the inputs } X \geq 0\}$. The primal input-oriented BCC model can be written in the form

$$\begin{aligned}
 & \min \theta \\
 & \text{subject to} \\
 & \sum_{j=1}^n X_j \lambda_j + S^- = \theta X_o, \\
 & \sum_{j=1}^n Y_j \lambda_j - S^+ = Y_o, \\
 & \sum_{j=1}^n \lambda_j = 1, \\
 & \lambda_j \geq 0, \quad j=1, \dots, n, \\
 & s_k^- \geq 0, \quad k=1, \dots, m, \\
 & s_i^+ \geq 0, \quad i=1, \dots, r,
 \end{aligned} \tag{1a}$$

where $X_j = (x_{1j}, \dots, x_{mj})$ and $Y_j = (y_{1j}, \dots, y_{rj})$ represent the observed inputs and outputs of production units $j = 1, \dots, n$, $S^- = (s_1^-, \dots, s_m^-)$ and $S^+ = (s_1^+, \dots, s_r^+)$ are vectors of slack variables. In this primal model the efficiency score θ of production unit (X_o, Y_o) is found; (X_o, Y_o) is any unit from the set of production units (X_j, Y_j) , $j = 1, \dots, n$.

Notice that we do not use an infinitesimal constant ε (a non-Archimedean quantity) explicitly in the DEA models, since we suppose that each model is solved in two stages in order to separate efficient and weakly efficient units.

The BCC primal output-oriented model can be written in the following form

$$\begin{aligned}
 & \max \eta \\
 & \text{subject to} \\
 & \sum_{j=1}^n X_j \lambda_j + S^- = X_o, \\
 & \sum_{j=1}^n Y_j \lambda_j - S^+ = \eta Y_o, \\
 & \sum_{j=1}^n \lambda_j = 1, \\
 & \lambda_j \geq 0, \quad j = 1, \dots, n, \\
 & s_k^- \geq 0, \quad k = 1, \dots, m, \\
 & s_i^+ \geq 0, \quad i = 1, \dots, r.
 \end{aligned} \tag{1b}$$

Definition 1. (Cooper et al., 2007). Unit $(X_o, Y_o) \in T$ is called efficient with respect to the input-oriented BCC model if any optimal solution of (1a) satisfies: a) $\theta^* = 1$, b) all slacks s_k^- , s_i^+ , $k = 1, \dots, m$, $i = 1, \dots, r$ are zero.

If the first condition (a) in Definition 1 is satisfied, then unit (X_o, Y_o) is called input weakly efficient with respect to the BCC input-oriented model. We denote the set of these weakly efficient points by $WEff_I T$. In the DEA literature (Banker and Thrall, 1992; Seiford and Thrall, 1990) this set is also called the input boundary.

Definition 2. (Cooper et al., 2007). Unit $(X_o, Y_o) \in T$ is called efficient with respect to the output-oriented BCC model if any optimal solution of (1b) satisfies: a) $\eta^* = 1$, b) all slacks s_k^- , s_i^+ , $k = 1, \dots, m$, $i = 1, \dots, r$ are zero.

If the first condition in Definition 2 is satisfied, then unit (X_o, Y_o) is called output weakly efficient with respect to the BCC model. We denote the set of these weakly efficient points by

$WEff_o T$. In the DEA literature (Banker and Thrall 1992; Seiford and Thrall 1990), this set is also called the output boundary.

Definition 3. (Cooper et al., 2007). Activity $(X', Y') \in T$ is weakly Pareto efficient if and only if there is no $(X, Y) \in T$ such that $X < X'$ and $Y > Y'$. We denote the set of weakly Pareto efficient activities by $WEff_p T$.

We denote the set of efficient points of T with respect to the BCC model (1) by $Eff T$. Krivonozhko et al. (2005) have proved that the following relations hold:

$$Eff T \subseteq WEff_i T \cap WEff_o T, WEff_i T \cup WEff_o T \subseteq WEff_p T = Bound T,$$

where the boundary of T is designated as $Bound T$.

The production possibility set T_B for the BCC model can be written in the form (Banker et al., 1984)

$$T_B = \left\{ (X, Y) \left| \sum_{j=1}^n X_j \lambda_j \leq X, \sum_{j=1}^n Y_j \lambda_j \geq Y, \sum_{j=1}^n \lambda_j = 1, \lambda_j \geq 0, j = 1, \dots, n \right. \right\}. \quad (2)$$

Definition 4. (Krivonozhko et al., 2015a) We call an efficient (vertex) unit terminal unit if an infinite edge is going out from this unit.

According to Krivonozhko et al. (2015a) only vectors of the following forms $\bar{d}_k = (d_k, 0) \in E^{m+r}$, $k = 1, \dots, m$, $\bar{g}_i = -(0, g_i) \in E^{m+r}$, $i = 1, \dots, r$ can be the direction vectors of infinite edges of set T_B . A set of such direction vectors for given terminal unit we call *terminal directions* associated with this unit.

We denote the set of terminal units with respect to the production possibility set (2) by T_{term} . The models for determination all terminal units of set T_B are given in the paper (Krivonozhko et al., 2015a). The relationship between T_{term} and other sets of units proposed for improving the frontier is established in (Krivonozhko et al., 2015b), where the following assertion was formulated:

$$T_{ext} \subseteq T_{anc}^3 \subseteq T_{term} \subseteq T_{anc}^1,$$

$$T_{anc}^2 \subseteq T_{anc}^3 \subseteq T_{term} \subseteq T_{anc}^1.$$

In these relations T_{anc}^1 denote the set of anchor units with respect to the definition of Bognol and Dulá (2009), T_{ext} denote the set of exterior units (Edvardsen et al., 2008), T_{anc}^2 and T_{anc}^3 are the sets of anchor units according to the definition of Thanassoulis et al. (2012, p.178) and generating by their model, respectively.

In the paper (Krivonozhko et al., 2015a) it was proved that only terminal units give a necessary and sufficient set of units as a basis for creating artificial units in order to improve the frontier. Thus, terminal units are the first “suspicious” units which may cause inadequate results in the DEA models.

Main results

Under the elaboration of the algorithm for smoothing the frontier we stick to the following principles:

- a) all efficient units have to stay efficient after the frontier transformation;
- b) every inefficient unit will be projected on the efficient part of the frontier.

First of all, all terminal units are determined. Models for discovering of such units are described in (Krivonozhko et al., 2015a). Then two-dimensional sections are constructed for every terminal unit. For our purposes we need three types of sections.

Let us define a section of the frontier with a two-dimensional plane (see Krivonozhko et al., 2004)

$$Sec(X_o, Y_o, d_1, d_2) = \{ (X, Y) \mid (X, Y) \in Pl(X_o, Y_o, d_1, d_2) \cap WEff_p T \},$$

where $Pl(X_o, Y_o, d_1, d_2)$ is a two-dimensional plane going through point (X_o, Y_o) and it spanned by vectors $d_1, d_2 \in E^{m+r}$.

In our exposition we will use the following three types of sections.

1. Input isoquant, section S_1 . In this case we take the following directions $d_1 = (e_p, 0) \in E^{m+r}$, $d_2 = (0, e_s) \in E^{m+r}$, where e_p and e_s are m -identity vectors with a one in position p and s , respectively.
2. Output isoquant, section S_2 . In this case vectors for cutting the frontier are determined as follows $d_1 = (0, e_p) \in E^{m+r}$, $d_2 = (0, e_s) \in E^{m+r}$, e_p and e_s are r -identity vectors with a one in position p and s , respectively.
3. Section S_3 reflects the dependence between variables y_p and x_s . For construction of such dependence we took directions: $d_1 = (0, e_p) \in E^{m+r}$, where e_p is r -identity vector with a one in position p , $d_2 = (e_s, 0) \in E^{m+r}$, e_s is m -identity vector with a one in position s .

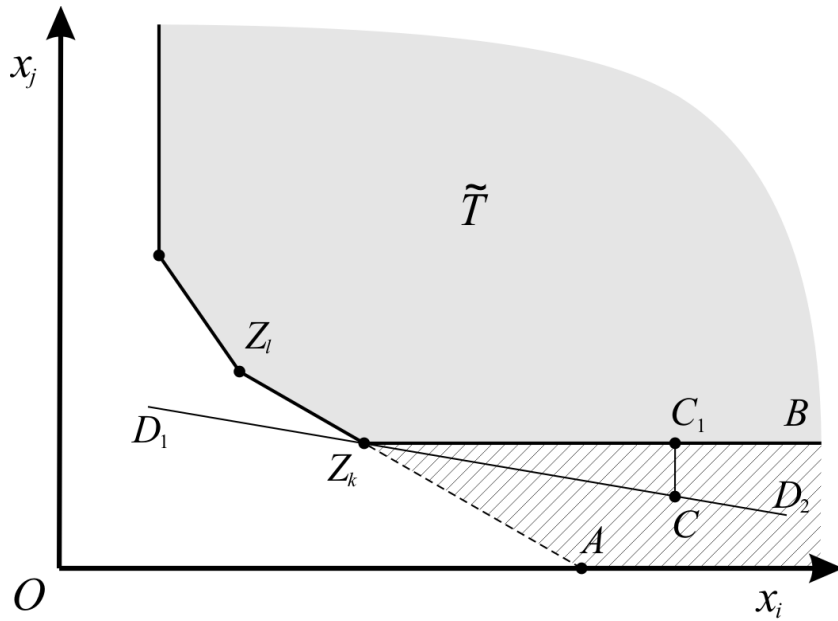

Figure 1. Terminal unit Z_k turns into just an efficient unit

Figure 1 represents an input isoquant for some terminal unit Z_k . If artificial unit C is inserted somewhere in the region limited by rays $Z_k B$, $Z_k A$ and axis Ox_i , then unit Z_k becomes just an efficient unit. Such operations can be accomplished for every terminal unit and for every type of sections going through this unit and that were described above. Observe that components of artificial unit C coincide with corresponding components of unit Z_k except coordinates that correspond to variables x_i and x_j . In other words, unit C belongs to the section that is going through point Z_k and is determined by variables x_i and x_j .

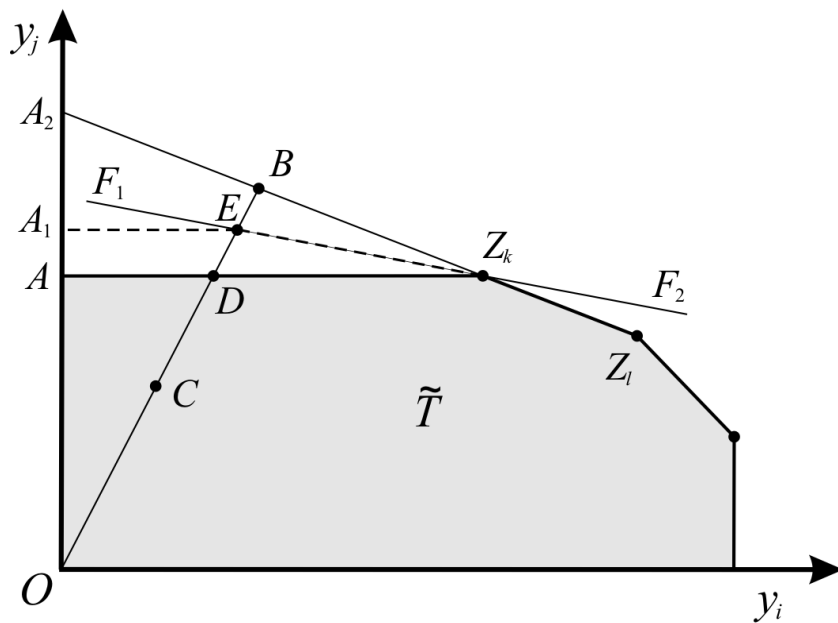

Figure 2. Removing the weakly efficient face AZ_k

Figure 2 depicts an output isoquant. The two-dimensional section, that is used for construction of this isoquant, is going through inefficient unit C and spanned by axes Oy_i and Oy_j . Unit C is projected on the weakly efficient part AZ_k of the frontier. If we insert artificial unit E somewhere on the ray CD , where point D is a projection of unit C on the frontier, and inside the region limited by rays AZ_k and Z_kB , where point B is a projection of point C on the ray Z_lZ_k , then unit C will be projected on the efficient point E belonging to the modified frontier. Notice that components of artificial unit E coincide with corresponding components of unit C except coordinates that correspond to variables y_i and y_j . In other words, unit E belongs to the section that is going through inefficient unit C and is determined by variables y_i and y_j .

Figure 3 shows a section of the frontier with two-dimensional plane that is going through terminal unit Z_k and is spanned by axes Ox_s and Oy_p . An artificial unit C is inserted somewhere in the region limited by rays Z_kB and Z_lZ_k . If we inserted an artificial unit C somewhere in the region limited by rays Z_lZ_k and Z_kB , then unit Z_k is transformed into just a usual efficient unit. Again, components of artificial unit C coincide with corresponding components of terminal unit Z_k except coordinates that correspond to variables x_i and x_j . In other words, unit C belongs to the section that is going through point Z_k and is determined by variables x_s and y_p .

For our purpose, it is sufficient to consider only these three types of sections described above.

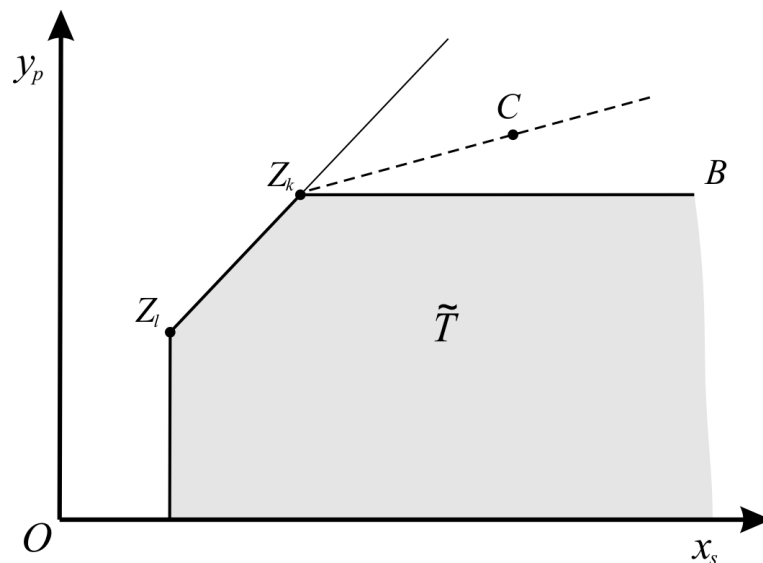

Figure 3. Section that reflects the dependence between variables y_p and x_s

Now, we describe a general scheme of the Algorithm for smoothing the frontier in DEA models.

Algorithm

Part 1. Smoothing terminal units

1. Compute efficiency scores for all production units $j = 1, \dots, n$.
 2. Find terminal units, i.e. determine set of terminal units T_{term} .
 3. For every terminal unit $j \in T_{term}$ do:
 - a) For every terminal direction do:
 - b) For every two-dimensional section, that contains this direction do:
 - c) Insert an artificial unit on the two-dimensional section outside the PPS in the current iteration.
 - d) Compute efficiency scores for all units.
If the number of an efficient unit is less than the original number, then move the artificial unit closer to the frontier, go to the beginning of step (d). Store the new artificial unit.
End (d)
 - End (c)
 - End (b)
 - End (a)
4. Include all artificial units in the set of production units of the PPS.

Part 2. Correction of the first part

1. Compute efficiency scores for all production units including artificial ones.
2. Find units that were efficient and become inefficient.
3. Find artificial units that caused the situations in the previous item.
4. While there exist artificial units that have to be corrected do:
 - a) Move all artificial units closer to the frontier.
 - b) Compute efficiency scores.
5. Delete inefficient artificial units.
6. Compute efficiency scores for all units including also artificial production units.

Part 3. Removing the weakly efficient faces of the frontier

1. While there exist units that are projected on the weakly efficient faces do:
 - a) Move projection on the weakly efficient faces along the radial direction outside the PPS, create artificial unit from such projection, and insert this artificial unit in the current iteration in the PPS.
 - b) Compute efficiency scores.
 - c) If the number of efficient units decreases, then decrease the distance of the new artificial unit from the frontier, go to (b).
 - d) Store the new artificial unit.
2. Include all artificial units in the set of production possibility units.

Part 4. Correction of the third part

1. Compute efficiency scores for all production units including artificial ones.
2. Find original units that were efficient and become inefficient.
3. Find artificial units that were inserted in the model for correction in the previous Part 3.
4. While there exist artificial units that should be corrected do:
 - a) Move all such artificial units simultaneously closer to the frontier along the radial direction.
 - b) Recompute efficiency scores.
5. Remove all inefficient artificial units in the model.
6. Finally, compute efficiency scores for all units in the model.

Observe that during the run of the Part 1 and Part 3 of the Algorithm some artificial units are inserted in the model. For this reason some efficient units may turn into inefficient ones since the configuration of the production possibility set (set of vertices, set of faces and their mutual disposition) may be changed. For this reason two additional stages (Part 2 and Part 4) are introduced in the Algorithm in order to correct such cases. This can be accomplished by moving artificial units closer to the corresponding faces.

Theorem. *After the run of the Algorithm the following results will be obtained:*

- 1) *all efficient units will be efficient;*
- 2) *all terminal units are transformed into just usual efficient ones;*
- 3) *all inefficient units are projected onto the efficient faces of the frontier.*

Proof. Consider the Part 1 of the Algorithm.

In the Algorithm, artificial units are generated in such a way that all efficient units (vertices) stay efficient and all terminal units turn into just efficient units. Indeed, the Algorithm

takes a two-dimensional section of the frontier for every terminal direction. Next, an artificial unit is inserted. Without any loss of generality, consider the two-dimensional section S_1 of the frontier, see Figure 1. As direction vectors of the section we took $d_1 = (e_i, 0) \in E^{m+r}$ and $d_2 = (e_j, 0) \in E^{m+r}$. Unit Z_k is a vertex and ray $Z_k B$ is an edge of the polyhedral set T . Hence a supporting hyper-plane can be constructed in such a way that it goes through point Z_k and has no other common points with set T . For this reason the hyper-plane cannot contain the two-dimensional section S_1 entirely, since in this case it would not be a supporting hyper-plane. So, this hyper-plane intersects section S_1 along some line $D_1 D_2$, see Figure 1. Line $D_1 D_2$ may take any position between rays $Z_k A$ and $Z_k B$. Insert an artificial unit C somewhere on the ray $Z_k D_2$ between rays $Z_k A$ and $Z_k B$, no new terminal units appear.

According to the construction, artificial unit C belongs to the two-dimensional section S_1 shown in the Figure 1. However some efficient units (vertices) may become inefficient. These units may be situated in the multidimensional space E^{m+r} . Assume that some efficient unit F become inefficient after inserting artificial point C in the production possibility set. Now unit C is a vertex of the modified set \tilde{T} . Move unit C closer to the set T along line CC_1 .

Any polyhedral set has a finite number of possible configurations (set of vertices, set of faces and their mutual disposition) if we move one vertex along a line. Hence there exists such position of vertex C on the line CC_1 that unit F become again efficient. This implies that the Algorithm can find such position on the segment CC_1 for a finite number of steps that all efficient units stay efficient and terminal units of the type Z_k are transformed into just efficient units.

The Algorithm processes successively all terminal units and terminal directions. Hence all terminal units are transformed into just efficient units and efficient units stay efficient.

So after the run of the first part of the Algorithm all terminal units of set T will turn into just efficient units (vertices) of the production possibility set, since Algorithm takes all sections going through every terminal units and based on their terminal directions.

Next, consider the Part 3 of the Algorithm. Let us take section S_2 as an example, see Figure 2, without any loss of generality.

In this case, the directional vectors of the two-dimensional section are $d_1 = (0, e_i) \in E^{m+r}$ and $d_2 = (0, e_j) \in E^{m+r}$. Let inefficient unit C be projected on the weakly efficient face, and let point D be a projection of point C .

Take some point E somewhere on the ray CD between segments Z_kA and Z_kA_2 . Point E is situated outside the current production possibility set \tilde{T} since it lies on the ray CD , point C is an interior point and point D is a boundary point of the production possibility set (Nikaido, 1968). A supporting hyper-plane can be built in such a way that it goes through point E and Z_k . Again, this hyper-plane intersects section S_2 along line F_1F_2 . This line may take any position between segments Z_kA and Z_kA_2 . Observe that in this case point Z_k may be an intersection of several faces in the multidimensional space E^{m+r} , see (Krivonozhko et al., 2014).

As in the previous case, there exists such position of artificial unit E on the open segment (D,B) that all efficient units stay efficient. This position can be found by Algorithm for a finite number of steps by moving unit E closer to the point D .

Observe that we do not need to construct some sections for this case. We use section S_2 , Figure 2, only for explanation. In reality, artificial point E can be inserted several times on segment DB , each time closer to point D , until all efficient units will stay efficient.

Such operations are repeated for every inefficient unit that is projected on the weakly efficient part of the frontier.

The case for section S_3 can be considered in a similar way.

Terminal unit is characterized by the fact that an infinite edge is going out from this unit.

Only vectors of the following forms $\bar{d}_k = (d_k, 0) \in E^{m+r}$, $k = 1, \dots, m$, $\bar{g}_i = -(0, g_i) \in E^{m+r}$, $i = 1, \dots, r$ can be the direction vectors of infinite edges of set T_B , see Krivonozhko et al. (2015). All types of sections that are used in Algorithm include all such direction vectors. Hence, all types of terminal units are used in the Algorithm for smoothing the frontier, and all types of weakly efficient faces belonging to $WEff_I T$ and/or $WEff_O T$ sets are smoothed by Algorithm using only three types of sections. In other words, all inefficient units will be projected on the efficient parts of the frontier.

Furthermore, some efficient units may become inefficient during the solution process as a result of changing of the production possibility set configuration when some artificial units are added to the current production possibility set. For this reason Part 2 and Part 4 were included in the Algorithm in order to correct such cases. New artificial units are moved closer to the frontier during the execution of Part 2 and Part 4, so all efficient units stay efficient at these stages.

This completes the proof.

Computational experiments

In our computational experiments we used the software FrontierVision, a specifically elaborated program by our team for the DEA models; see Krivonozhko et al. (2014). This program allows us to visualize the multidimensional production possibility set by means of constructing two- and three-dimensional sections of the frontier.

At first, we took data from 174 Russia bank's financial accounts for January 2009. We used the following variables as inputs: working assets, time liabilities, and demand liabilities. As output variables we took: equity capital, liquid assets, fixed assets.

Max, min and mean statistics are presented in Table 1.

Table 1. Data for Russian banks, January 2009

Variables	Mean	St. deviation	Min	Max
<i>Outputs</i>				
Y_1 – Liquid assets, bln roubles	6,62	9,36	0,18	63,93
Y_2 – Equity capital, bln roubles	3,52	4,82	0,52	26,86
Y_3 – Fixed assets, bln roubles	1,02	1,32	0,01	6,92
<i>Inputs</i>				
X_1 – Demand liabilities, bln roubles	15,16	18,16	0,55	105
X_2 – Time liabilities, bln roubles	27,06	37,86	0,34	191,6
X_3 – Working assets, bln roubles	36,49	47,34	1,83	249,2

Fig. 4 represents two input isoquants for unit 149 that are intersections of the six-dimensional production possibility set with two-dimensional planes for unit 149. This unit in the figure is shown by white circle. Other small color circles represent orthogonal projections of actual and artificial units onto the section. The red color means that the corresponding unit is efficient. The green and yellow colors denote units with low and intermediate values of efficiency score, respectively. The curve 1 shows input isoquant for the original set T . The curve 2 is built for the transformed set \tilde{T} . Directions of the two-dimensional plane are determined by the following inputs: demand liabilities and time liabilities.

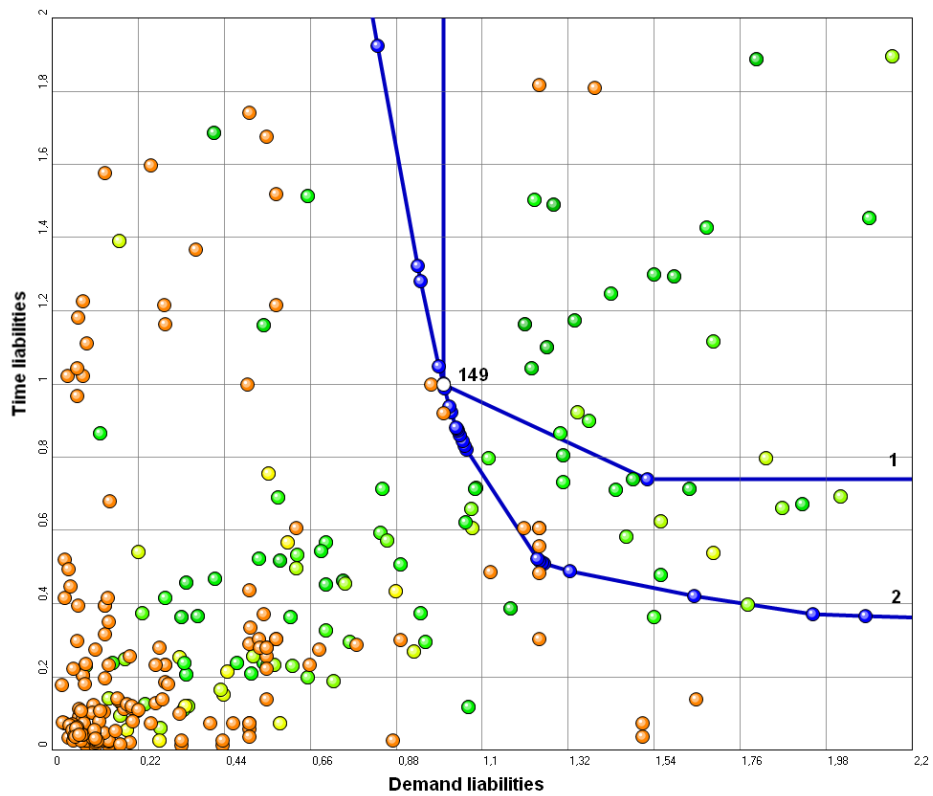

Figure 4. Input isoquant for unit 149

Fig. 5 depicts two output isoquants for unit 53, these curves are intersections of the six-dimensional production possibility set with two-dimensional plane for unit 53. Directions of the plane are taken as follows: fixed assets and liquid assets. The curve 1 shows input isoquant for set T and curve 2 is input isoquant for the transformed set \tilde{T} . The number of originally efficient units among banks is 26. The number of inefficient units is 148. Almost all inefficient units are projected onto the weakly efficient parts of the frontier, set $WEff_{,T}$ and/or $WEff_{oT}$, this number is equal to 146.

The Algorithm inserted 412 artificial units in the original set of units in order to smooth the frontier.

Input isoquants, see Fig. 4, are constructed for efficient unit 149. However, they have only one common point, unit 149, this means that curve 1 consists mainly of weakly efficient point of the frontier except unit 149.

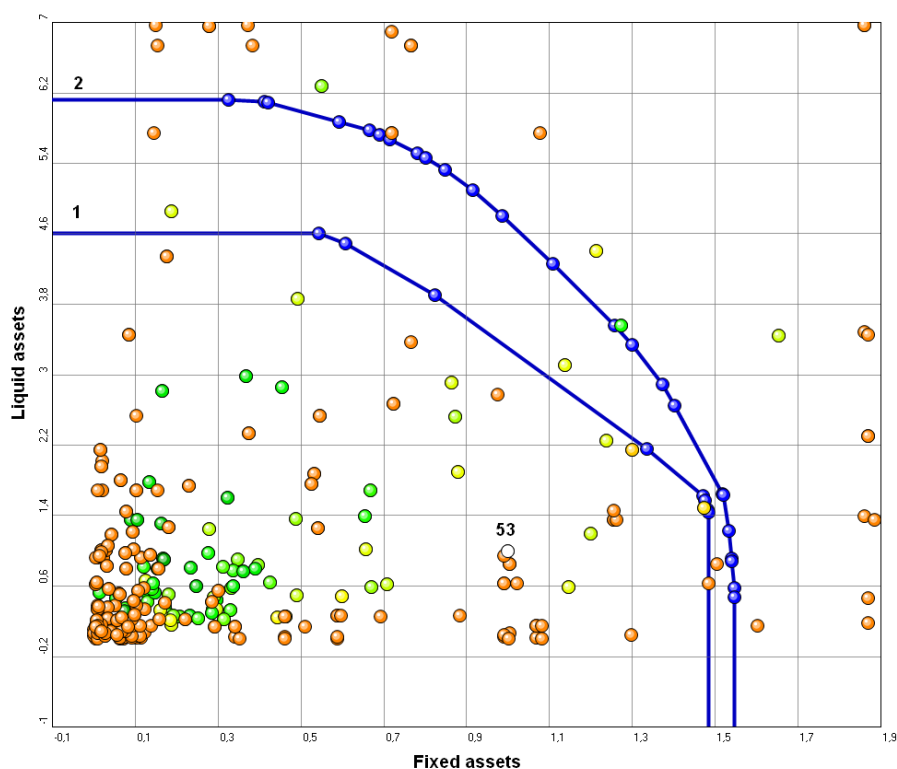

Figure 5. Output isoquant for unit 53

Output isoquants, see Fig. 5, are built for efficient unit 53. Curves 1 and 2 have no common points. This implies that this curve consists only from weakly efficient points of the original frontier. So, curve 2 embraces curve 1 completely.

After running the Algorithm, all inefficient units are projected onto efficient parts of the frontier. Bognol and Dulá (2009) observed that almost all extreme efficient units are anchor units. So, it would be interesting to check: how many inefficient units are projected onto the weakly efficient faces of the frontier in other real-life models.

To achieve this purpose, we expanded our computational experiments and included in it two additional datasets. We took the data for electricity utilities on Sweden 1987, see Førsund et al. (2007). The number of production units in this model is 163, among these units there are 110 inefficient units. And 109 inefficient units are projected on the weakly efficient parts of the frontier.

As the second additional dataset, we took data of the nursing and home care sector of Norwegian municipalities. There are three inputs and ten outputs in this model, see details in Erlandsen and Førsund (2002). This model has 469 original units. Computations on the BCC model show that there are 129 efficient units among them and 340 inefficient ones. All these inefficient units are projected onto the weakly efficient faces of the frontier.

Hence the frontier in the DEA models is really needed for improving.

Conclusions

In this paper, we proposed a general algorithm for improving the frontier in the DEA models. Strictly speaking, only a general scheme of the Algorithm was described in detail since Algorithm can be realized in many different forms that depend on original program modules used for Algorithm constructions, sizes of the datasets that has to be analyzed, socio-economic areas where DEA models are used and so on.

Computational experiments using real-life datasets confirmed that the Algorithm works reliably and improves the frontier significantly. Our software FrontierVision, specifically elaborated for visualization of the frontier, demonstrates that our two-dimensional sections of the improved frontier looks almost like economic functions in text-books on economics. The improved frontier may significantly increase the accuracy of the DEA models.

References

- Allen R., Thanassoulis E. (2004). Improving envelopment in data envelopment analysis. *European Journal of Operational Research* 154(2): 363–379.
- Banker R.D., Charnes, A., Cooper, W.W. (1984). Some models for estimating technical and scale efficiency in data envelopment analysis. *Management Science* 30: 1078–1092.
- Banker R.D., Thrall R.M. (1992). Estimation of returns to scale using data envelopment analysis. *European Journal of Operational Research* 62(1): 74–84.
- Bougnol M.-L., Dulá J.H. (2009). Anchor points in DEA. *European Journal of Operational Research* 192(2): 668–676.
- Brockett P. L., Charnes A., Cooper W. W., Huang Z. M., Sun D. B. (1997). Data transformations in DEA cone ratio envelopment approaches for monitoring bank performance. *European Journal of Operational Research* 98: 250–268.
- Charnes A., Cooper W.W., Huang Z.M., Sun D.B. (1990). Polyhedral cone-ratio DEA Models with an Illustrative Application to Large Commercial Banks. *Journal of Econometrics* 46: 73–91.
- Charnes A., Cooper W. W., Wei Q. L., Huang Z. M. (1989). Cone ratio data envelopment analysis and multi-objective programming. *International Journal of Systems Science* 20: 1099–1118.
- Cooper W.W., Seiford L.M., Tone K. (2007). *Data Envelopment Analysis. A Comprehensive Text with Models, Applications, References and DEA-Solver Software*. (Second edition) New-York: Springer Science and Business Media.
- Edvardsen D.J., Førsund F.R., Kittelsen S.A.C. (2008). Far out or alone in the crowd: a taxonomy of peers in DEA. *Journal of Productivity Analysis* 29: 201–210.
- Erlandsen E., Førsund F.R. (2002). Efficiency in the provision of municipal nursing-and home care services: the Norwegian experience. In: Fox K.J. (eds.) *Efficiency in the public sector*, chapter 10. Kluwer, Boston/Dordrecht/London, pp 273–300.

- Farrell, M.J. (1957). The measurement of productive efficiency. *Journal of the Royal Statistical Society, Series A (General)* 120(III): 253–281(290).
- Førsund F.R., Hjalmarsson L., Krivonozhko V.E., Utkin O.B. (2007). Calculation of scale elasticities in DEA models: direct and indirect approaches. *Journal of Productivity Analysis* 28: 45-56.
- Krivonozhko V.E., Førsund F.R., Lychev A.V. (2014). Measurement of returns to scale using non-radial DEA models. *European Journal of Operational Research* 232(3): 664–670.
- Krivonozhko V. E., Førsund F. R., Lychev A. V. (2015b). On comparison of different sets of units used for improving the frontier in DEA models. *Annals of Operation Research*. DOI: 10.1007/s10479-015-1875-8.
- Krivonozhko V. E., Førsund F. R., Lychev A. V. (2015a). Terminal units in DEA: definition and determination. *Journal of Productivity Analysis* 42(2): 151-164.
- Krivonozhko V. E., Utkin O. B., Safin M. M., Lychev A. V. (2009). On some generalization of the DEA models. *Journal of the Operational Research Society* 60: 1518–1527.
- Krivonozhko V. E., Utkin, O. B., Volodin A. V., Sablin I. A. (2005). About the structure of boundary points in DEA. *Journal of the Operational Research Society* 56: 1373–1378.
- Krivonozhko V. E., Utkin O. B., Volodin A. V., Sablin I. A., Patrino M. V. (2004). Constructions of economic functions and calculations of marginal rates in DEA using parametric optimisation methods. *Journal of the Operational Research Society* 55(10): 1049–1058.
- Nikaido, H. (1968). *Convex structures and economic theory*. New York: Academic Press.
- Podinovski V.V. (2007). Improving data envelopment analysis by the use of production trade-offs. *Journal of the Operational Research Society* 58(10): 1261-1270.
- Podinovski V.V. (2015). DEA models with production trade-offs and weight restrictions. In J. Zhu (Ed.), *Data envelopment analysis: A handbook of models and methods* (pp. 105–144). New York: Springer Science + Business Media.
- Seiford L.M., Thrall R.M. (1990). Recent developments in DEA: the mathematical programming approach to frontier analysis. *Journal of Econometrics* 46(1–2): 7–38.
- Thanassoulis E., Allen R. (1998). Simulating weight restrictions in data envelopment analysis by means of unobserved DMUs. *Management Science* 44(4): 586–594.
- Thanassoulis E., Kortelainen M., Allen R. (2012). Improving envelopment in Data Envelopment Analysis under variable returns to scale. *European Journal of Operational Research* 218(1): 175–185.
- Thompson R. G., Brinkman E. S., Dharmapala P. S., Gonzalez-Lima M. D., Thrall R. M. (1997). DEA/AR profit ratios and sensitivity of 100 large U.S. banks. *European Journal of Operational Research* 98: 213–229.
- Thompson R. G., Langemeier L. N., Lee C.-H., Lee E., Thrall R. M. (1990). The role of multiplier bounds in efficiency analysis with application to Kansas farming. *Journal of Econometrics* 46: 93-108.
- Wei Q., Yan H., Xiong L. (2008). A bi-objective generalized data envelopment analysis model and point-to-set mapping projection. *European Journal of Operational Research* 190: 855–876.
- Yu G., Wei Q., Brockett P. (1996). A generalized data envelopment analysis model: a unification and extension of existing methods for efficiency analysis of decision making units. *Annals of Operations Research* 66: 47–89.