

Radanliev, Petar

Article — Published Version

Engineering Design Methodology for Green-Field Supply Chain Architectures - Taxonomic Scheme

Journal of Operations and Supply Chain Management

Suggested Citation: Radanliev, Petar (2015) : Engineering Design Methodology for Green-Field Supply Chain Architectures - Taxonomic Scheme, Journal of Operations and Supply Chain Management, ISSN 1984-3046, Escola de Administração de Empresas de São Paulo of the Fundação Getulio Vargas, São Paulo, Vol. 8, Iss. 2, pp. 52-66, <http://dx.doi.org/10.12660/joscmv8n2p52-66> , <http://bibliotecadigital.fgv.br/ojs/index.php/joscm/article/view/58041/56509>

This Version is available at:

<http://hdl.handle.net/10419/162765>

Standard-Nutzungsbedingungen:

Die Dokumente auf EconStor dürfen zu eigenen wissenschaftlichen Zwecken und zum Privatgebrauch gespeichert und kopiert werden.

Sie dürfen die Dokumente nicht für öffentliche oder kommerzielle Zwecke vervielfältigen, öffentlich ausstellen, öffentlich zugänglich machen, vertreiben oder anderweitig nutzen.

Sofern die Verfasser die Dokumente unter Open-Content-Lizenzen (insbesondere CC-Lizenzen) zur Verfügung gestellt haben sollten, gelten abweichend von diesen Nutzungsbedingungen die in der dort genannten Lizenz gewährten Nutzungsrechte.

Terms of use:

Documents in EconStor may be saved and copied for your personal and scholarly purposes.

You are not to copy documents for public or commercial purposes, to exhibit the documents publicly, to make them publicly available on the internet, or to distribute or otherwise use the documents in public.

If the documents have been made available under an Open Content Licence (especially Creative Commons Licences), you may exercise further usage rights as specified in the indicated licence.



<http://creativecommons.org/licenses/by/4.0/>

Engineering Design Methodology for Green-Field Supply Chain Architectures Taxonomic Scheme

Petar Radanliev

Anglia Ruskin University, Lord Ashcroft International Business School
petar.radanliev@anglia.ac.uk

ABSTRACT: Supply chain engineering requires a design that possesses the flexibility of a complex adaptive system, consisting of interlinking architecture, with external dimensions and system germane internal elements. The aim of this paper is to critically analyse the key supply chain concepts and approaches, to assess the fit between the research literature and the practical issues of supply chain architecture, design and engineering. The objective is to develop a methodology for strategy engineering, which could be used by practitioners when integrating supply chain architecture and design. Taxonomic scheme is applied to consider criteria for strategy architecture, hierarchical strategy integration design, strategy engineering, and integration of supply chain as a conceptual system. The results from this paper derived with the findings that the relationship between supply chain architecture, design and engineering is weak, and challenges remain in the process of adapting and aligning operations. This paper derived with a novel approach for addressing these obstacles, through a conceptual framework diagram and a new methodology, based on the taxonomic scheme. The novelty that derives from this paper is an engineering design methodology for integrating supply chain architecture and design, with criteria that enable decomposing and building a green-field (new and non-existent) supply chain as a system. The taxonomic scheme revealed a number of tools and mechanism, which enabled the development of a new methodology for engineering integrated architecture and design. The review derived with improvements to current and existing theories for analysing interdependencies within and between their individual contexts. This issue is addressed with a hierarchical method for network design, applied for building and combining the integration criteria. The resulting methodology is field tested through a case study with the slate mining industry in North Wales.

Keywords: *Supply chain architecture, supply chain design, green-field supply chain conceptual engineering.*

1. INTRODUCTION

The progress of integrating supply chain principles is weak, specifically towards 'adapting' (Saad et al., 2002) and 'aligning' (Sakka et al., 2011). Supply chain decisions are commonly based on individual company profitability goals (Leng and Chen, 2012), undermining that supply chain is a single entity system (Mintzberg et al., 1998, Schnetzler et al., 2007, Narasimhan et al., 2008, Ivanov, 2009, Perez-Franco et al., 2010). In addition, the supply chain strategy in practice is frequently not related to the competitive strategy (Mckone et al. 2009). This findings create the rationale for further investigation on how supply chain strategies are engineered, and the overarching architectures that enable integration of operations.

Supply chain engineering has been defined as a complex adaptive system (Bozarth et al., 2009, Pathak et al., 2007), consisting of interlinking architecture and design, with external dimensions and system germane internal elements (Melnyk et al., 2013). Supply chain strategic engineering represents an effective method for implementing strategic integration (He and Lai, 2012). However, further research is required to include the relationship of change in culture and structure to integration (Nikulin, et al. 2013).

Supply chain strategy engineering as a green-field concept of non-existent until formulated supply chain, should embrace collaborative commerce and synchronisation of information flow (Frohlich and Westbrook, 2001, Vickery et al., 2003, Al-Mudimigh et al., 2004, Manthou et al., 2004, Kim, 2006).

The area of research for this paper is the field of supply chain engineering that include the external architecture and internal design, in a green-field engineering (new and non-existent supply chain). To evaluate the present approaches in supply chain practice, the paper begins with a review of existing supply chain models, which cover the relevant aspects of green-field supply chain integration. The research areas reviewed are: supply chain engineering, supply chain architecture, supply chain design, and supply chain integration.

There is a vast number of developed or proposed supply chain models focused on one or more supply chain areas. The objective of this paper is to group the factors in recognisable taxonomic scheme, and to derive with a new set of principles for green-field supply chain strategy engineering of the supply chain architecture and design.

1.1 Research Objectives

The research problems investigated are related to engineering the integration of supply chain architecture and design. The research objectives are:

1. To derive with a set of principles for a green-field supply chain architecture with multiple supply chain participants.
2. To derive with set of principles for green-field supply chain integration design.
3. To systematically integrate the supply chain engineering principles, based on the architecture and design criteria, for individual activities towards pre-defined green-field integration areas.

To relate the criteria to the methodology, the taxonomic scheme is presented in a hierarchical concept map and concept diagram methods are applied. The objectives of the paper are oriented around external and salient dimensions, which directly affect the supply chain architecture, and design, and the supply chain engineering consist of external and internal elements, forces and factors.

1.2 Structure of the paper

This paper is structured in the following order: **firstly** the research aim and objectives are defined, along with the rationale for the study; **secondly**, the literature review outlines the most prominent models and methods in this field; **thirdly**: the reasoning behind key tenants of the methodology are discussed in detail, with specific observations from existing literature on this topic; **fourthly**, the methodology that derived from this study is presented, followed by the principles key, containing the key tenets and abbreviations. The fourth step also relates the key tenets to existing literature and elaborates on the benefits from the methodology to practitioners and academics; and **finally**, the emerging principles are analysed to clarify how the key tenets are applied to the new methodology for engineering green-field supply chain architecture and design. To clarify how the methodology can be interpreted and applied, the methodology is field-tested through case study on the Slate Mining Industry in North Wales.

2. LITERATURE REVIEW

The literature review reveals the most prominent literature and outlines the tools and mechanisms that

enabled this paper to derive with the principles for engineering green-field supply chain integration. The objective of the literature review is to analyse the key tenets that enable the architecture for inter-relating the design of supply chain operations.

Recent literature addressed the aspect of reformulating existing supply chains when problems emerge (Nikulin, et al. 2013, Melnyk et al., 2013, Perez-Franco 2010). However, those studies ignored the vast list of measurements in existing literature (Van der Vaart and van Donk, 2008) and the diverse external dimensions and the elements, factors and forces that are present in different environments (Radanliev, 2015a).

Nikulin, et al. (2013), Melnyk et al., (2013), and Perez-Franco (2010) addressed the aspect of re-engineering, while Van der Vaart and van Donk, (2008) defined the re-engineering strategic patterns. Nevertheless, the topic of formulating a supply chain strategy as a green-field concept, remains elusive and most of the closely related frameworks (Radanliev, 2015b, Schnetzler et al., 2007, Hafeez, et al. 1996, and Pettigrew, 1977) have never advanced into full working methodologies, defining the engineering in a step by step supply chain engineering design.

There is much confusion in existing supply chain literature on terminologies defining re-engineering and engineering (Radanliev, 2015c). Terms such as supply chain engineering, design or architecture are commonly used in supply chain re-engineering studies, effectively referring to re-designing. The research in this paper distances from the aspect of re-engineering and is focused on the engineering of non-existent supply chains in a green-field context. Therefore, the term green-field is a clarification concept referring to non-existent supply chains, in other words, the field is green, and there is nothing there.

3. RESEARCH METHODOLOGY

The research methodology applied in this paper was taxonomy of approaches from literature review. The selected papers have been related to supply chain strategy, distancing from supply chain management. Recent literature clearly separated between the topics of supply chain management and supply chain strategy (Perez-Franco et al., 2010, Schnetzler et al., 2007, Martínez-Olvera and Shunk, 2006). Supply chain management has been defined as the process of transforming materials into a finished product, presenting a long term objective where validation should expand over a long period

of time (Saad et al., 2002, Mentzer et al., 2001). The supply chain strategy was considered as an investigation into how the supply chain should operate efficiently to compete, by evaluating costs, benefits and trade-offs in the supply chain operational components (Perez-Franco et al., 2010, Schnetzler et al., 2007, Martínez-Olvera and Shunk, 2006).

In exception of a few cases, the papers have been selected with a research time horizon over the last 10 years (2005-2015), covering literature published on the topic of supply chain strategy engineering. A limited number of most prominent papers from earlier literature have also been reviewed, because of their specific contribution to the topic of green-field supply chain strategy engineering.

By distancing from the area of supply chain management, the number of relevant papers was reduced dramatically. This focused the review of literature specific to the engineering aspect of a supply chain strategy, and building a methodology for green-field supply chain strategy engineering.

Over seventy papers have been reviewed, covering empirical techniques (case/field study, survey, archival research, action research, conceptual models) or modelling techniques (optimisation, simulation, algorithms, systems). What united all the papers reviewed is their singular focus on supply chain strategy, was identified as a topic far less covered in existing literature than supply chain management.

Multiple methods have been used to search for appropriate literature, to provide transparency, and to reduce risk of missing out on important literature. The databases used include the Web of Science and the Business Source Complete. In addition, Google Scholar was used to ensure the literature selected provides a wide coverage of the topic. The initial results produced more results than a single study can handle. The process of selecting the most pertinent literature involved applying selection criteria. The selection criteria are based on deriving with keywords and scanning first the titles for those word. Secondly, the selected literature was further reduced by scanning the abstract to ensure direct relevance to the topic.

The complexity of the subject, the multiple environments, dimensions, elements and concepts, required a research that does not set any limits to categorising the conceptual, analytical or empirical nature of the existing approaches. Many of the approaches identi-

fied in literature are focused on resolving singular supply chain problems, and are not relating to other aspects of supply chain engineering. This presented the rationale for applying a taxonomic scheme to investigate, interrelate and group the attitudes, practices and patterns, present in existing literature on the topics of supply chain: engineering, integration, architecture and design. The taxonomic scheme enabled categorising concepts into different clusters. The categorisation enabled the process of recognising, differentiating and understanding different attitudes, practices and patterns for engineering supply chain strategy, and interrelating them in accordance to positive relationships between different concepts.

But in general, many of the studies have hardly built on previous work. The taxonomic scheme enabled combining and pairing factors and elements from different papers, because they were based on the same aspect of research, and discussed the same constructs and items in terms of supply chain strategy engineering. As a result of the taxonomic scheme, the analysis derived with the most prominent attitudes, patterns, and practices for supply chain engineering, and the interactions, or interrelationships between these factors.

The synthesised knowledge is then applied for building a methodology integrating the approaches in existing literature on supply chain strategy engineering.

The papers have been analysed around a taxonomy of characteristics, to map and evaluate green-field supply chain strategy engineering. The different approaches have been categorised in hierarchical methodology.

The case study method was applied to field-test the resulting methodology on formulating a green-field supply chain strategy for the Slate Mining Industry in North Wales.

4. TAXONOMIC SCHEME

4.1 Green-field strategic integration

The process of merging distinct green-field operational areas into the supply chain area, creates an urgency to integrate the information and physical flow into relationships that link these areas and fosters 'trust and commitment' (TC) with supply chain partners (Bozarth et al., 2009). Pathak et al. (2007) designed a set of principles based on TC, however,

the principles would benefit from being tested with case study, in a similar way that other frameworks are field-tested (Perez-Franco et al., 2010, Narasimhan et al., 2008, Martínez-Olvera, 2008, Martínez-Olvera and Shunk, 2006). In addition, these frameworks would benefit from criteria to evaluate and measure performance of integrating supply chain participants into a 'networked organisation' (NO) (Sukati et al., 2012). Where performance depends on 'identification of best candidates' (IBC) (Lee and Billington, 1992), and requires measurement system for 'interdependence and organisational compatibility' (IOC) in supply chain design (Beamon, 1998).

4.2 Characterising green-field integration

'Supply chain strategy integration' (SCI) is described as a 'single entity system' or a 'confederation' (Mentzer, 2001) and a 'networked organisation' (Ivanov, 2009). The 'single entity system' should be focused on 'capturing the essence and forecasting the effect' of supply chain integration and performance (CEFE) (Mentzer, 2001), through combining resources and capabilities (Narasimhan et al., 2008). In addition, to 'characterise greenfield supply chain strategy and integration' (CGSI) the functional activities should be investigated to identify actual instead of desired strategy outcomes (Cigolini et al., 2004).

Strategic integration represents an effective method for implementing strategic choices and further research is required to include the 'architecture implementation' (FI) in integration (He and Lai, 2012). To address this, an algorithm has been described for selecting best supply chain integration strategy through separation in 'space, time, parts and conditions' (STPC) for scenarios when problems occur (Nikulin et al. 2013). The soundness and the logic behind Nikulin et al. (2013) approach could be applied as a tool to build upon a framework for supply chain strategy architecture. Such framework should embrace collaborative commerce and synchronisation of supply chain information flow, promoting flexibility and effectiveness (Frohlich and Westbrook, 2001, Vickery et al., 2003, Al-Mudimigh et al., 2004, Manthou et al., 2004, Kim, 2006).

4.3 Categorising green-field integration activities

Supply chain competences lead to diverse performance advantages in various business environments (Closs and Mollenkopf, 2004), but the same practices and patterns cannot be applicable in every industry

context to achieve superior performance (Nikulin et al., 2013, Van der Vaart and van Donk, 2008, Vickery et al., 2003). Factors that improve supply chain integration and performance have been categorised into attitudes, practices and patterns (Van der Vaart and van Donk, 2008). The relationship between these clusters remains elusive and the number of 'architecture elements' (FE) and 'architecture concepts' (FCo), should be validated through further research. Formulating supply chain strategies in the context of 'green-field architecture' (GF) with a singular focus on integration and performance (Frohlich and Westbrook, 2001), presents limitations (Childerhouse and Towill, 2011, Perez-Franco et al., 2010, Rosenzweig et al., 2003), because various supply chain aspects should be considered in the design and architecture stage, and supply chain integration activities have a unique set of benefits (Swink et al., 2007).

A holistic framework for supply chain design (Melnyk et al. 2013) concluded that supply chain design must consider the 'external dimension' (ExD). The study recommended a process for uncovering the various pieces that orchestrate the overall supply chain architecture and design, through investigating the 'underlying factors' (UF) and 'salient dimensions' (SaD), such as 'external elements' (EE), 'factors' (EFa), and 'forces' (EFo) (Melnyk et al. 2013).

4.4 Green-field supply chain decomposition design

Supply chain design is a dynamic process and interdependencies should be analysed 'within' and 'between' in individual context (Dubois et al., 2004). One approach for building and combining the criteria is a hierarchical method for network design (Dotoli et al., 2005). This approach can be strengthened by building upon the principles from 'Analytical Target Cascading' in context of decomposing a complete supply chain hierarchical tree (Qu et al., 2010), similarly to 'decomposing supply chain into hierarchical tree' (DSCHT) (Schnetzler et al. 2007). The DSCHT combined with the techniques from the customer-product-process-resource (CPPR) (Martínez-Olvera and Shunk, 2006) and 'analytical target cascading' (ATC), provide the background for designing a new engineering method that would include the process of getting from the 'present to (the) required' stage (PR).

The design process could apply a 'conceptual approach for supply chain inter-organisational integration' (CSCIOI) (Perez-Franco et al., 2010). Alter-

natively, conceptual system can be verified with system dynamics and mathematical modelling (Ivanov, 2009), however, mathematical modelling could hardly calculate with precision the perceptions of the individual decision maker perceptions.

Engineering systems literature integrated a system dynamics principles to decompose supply chain and tested the approach through dynamic analysis (Hafeez et al., 1996). The engineering system approach could be applied as a visualisation tool for presenting and interlinking multiple supply chain areas with external business dimensions (Lertpattarapong, 2002), but such approach could hardly comprehend the supply chain complexities and multiple variables in 'integration as a method for integrating strategic choices' (IMSC), leading to the conclusion that conceptual architectures and supply chain decomposition design are stronger visualisation tools.

Nevertheless, engineering design techniques such as the Pugh Controlled Convergence (Pugh, 1990), the Enhanced Quality Function Deployment (Clausen, 1992), the Design Structure Matrix (Eppinger et al., 1994) the Engineering System Matrix (Bartolomei et al., 2007), and the 'techniques tool matrix' (Cigolini et al., 2004), can be applied in combination with 'cascading strategy' (Narasimhan et al., 2008), to case study, to build the supply chain strategy engineering architecture and design as a conceptual system (Perez-Franco et al., 2010). Such an approach can be combined with supply chain decomposition (Schnetzler et al., 2007) to address the 'architecture criteria' (FCr) problem.

4.5 Green-field conceptual engineering

'Conceptual model' approach (CM) has been applied for strategy architecture to evaluate decision makers strategic goals (Perez-Franco et al., 2010, Narasimhan et al., 2008, Cigolini et al., 2004). Therefore, 'a conceptual system for supply chain decomposition' (CSSCD), could integrate operational level employees to identify relationship between the vision and goals and for explaining the relationship between concepts (Platts et al., 1996, Menda and Dilts, 1997).

4.6 Ontological semantic alignment for green-field design

Alternatively, an 'ontological approach can be applied for semantic alignment' (OASA) where knowledge elicitation, containing, mapping and merging should represent the foundations for adapting or aligning

supply chain principles (Sakka et al., 2011). The process should conceptualise strategy as a system of choices, patterns or decisions to address the phenomenon of 'strategy absence' (SA) in strategy architecture (Inkpen and Choudhury, 1995). The process should start by reaching a consensus on the 'preliminary salient dimensions' (PSaD) and strategic objectives (Platts et al., 1996, Menda and Dilts, 1997). The process can be further clarified by applying 'architecture criteria' (FC), such as: procedure, process and participation, which require communication mechanisms to enable concept understanding (Inkpen and Choudhury, 1995). The concept understanding should apply design 'integration criteria' (EC) through systematic innovation (Sheu and Lee, 2011), as a method for distilling innovation to strategy. However, strategy absence must be addressed through the architecture criteria prior to applying the integration criteria, because systematic innovation brings strategy dynamics through the 'process chain and virtual eChain' (PC-VC) feedback mechanisms, whereas strategy absence effectively disables the feedback mechanisms and reduces the 'supply chain agility' (SCA).

The feedback mechanisms enable the process of: (1) anticipating the demand for a product, market standards and influencers, product variety and life cycle (Fisher, 1997); (2) investigating the internal and external factors (Narasimhan et al., 2008); (3) determine the supplier or customer focus and level of integration (Frohlich and Westbrook, 2001); and (4) enable building trust and commitment, or interdependence and organisational compatibility (Mentzer, 2001). These feedback mechanisms enable building upon the supply chain architecture criteria and until present, the architecture criteria has not been combined with the 'integration criteria' (EC): visibility (Inkpen and Choudhury, 1995, Fisher, 1997), acceptance (Saad et al., 2002), participation (Menda and Dilts, 1997, Zhou and Chen, 2001, Qureshi et al., 2009), communication (Tracey et al., 1999), formality (Andrews et al., 2009), adaptability (Sakka et al., 2011, Saad et al., 2002), integration (Bozarth et al., 2009), effectiveness (Fisher, 1997) flexibility (Kim, 2006) and responsiveness (Fisher, 1997). Building upon and combining the criteria would represent a novel contribution from synthesising existing knowledge for deriving new findings.

4.7 Green-field supply chain engineering in uncertain environments

Recent literature are the indications that supply chain engineering and competitive strategy are com-

monly not linked to the 'corporate strategy' (CS) (Mckone et al., 2009). Adding to these concerns are the findings that challenges still remain in the processes for 'adapting and aligning' (AA) supply chain engineering (Saad et al., 2002) and operations (Sakka et al., 2011). The strategy architecture represents a process of 'capabilities integration' (CE) and accepting the reality and acting upon that reality in a given business environment (Miller and Friesen, 1978). The supply chain engineering topic remains inconclusive and there are remaining 'barriers to change and approaches to overcome' (BCAO) (Mckone et al., 2009, Saad et al., 2002, Sakka et al., 2011).

In a similar context, various algorithms have been applied to several supply chain problems, however, in some environments the 'participants aims and objectives' (PAO) problem is larger than the test data and optimal solutions cannot be found in reasonable time frame (Lee et al., 2010) leading to 'strategy absence' (SA). Metaheuristic algorithms could in the future provide a solution for identifying optimal logistic solution for supply chain strategy design (Griffis et al., 2012). Such a method would be useful for addressing the logistics as a specific problem in strategy architecture. However, metaheuristics would hardly anticipate aspects such as the individual decisions of decision makers in the vast numbered dimensions in multiple business environments. In this context, the conceptual system approach has been proven effective for 'supply chain strategy articulation' (SCSA) and optimal solution detection (Perez-Franco et al., 2010).

4.8 Supply chain efficiency of green-field architectures

The process of determining the underlying factors of salient dimensions in supply chain engineering, should be focused on preserving core-activities and outsource non-core activities (Gilley and Rasheed, 2000). For example, in the 'transport and logistics strategy' (TLS) third party logistic partnerships enable cost reduction combined with improvement in service and operational efficiency (Sheffi, 1990), bringing into focus the 'transportation and logistics integration strategic elements' (TLISE). In this context, further investigation of a potential 'fit' between companies outsourcing intensities and vertical strategic integration could strengthen existing understanding of the 'outsourcing through abstention' (OTA) problem (Gilley and Rasheed, 2000). Since greater collective operational activities need to be advanced through supply chain alliances, then the

strategic problem of 'integration as a method for integrating strategic choices' (IMSC) grows into one of a degree (Frohlich and Westbrook, 2001), however, the right level of 'fit, intensity and integration' (FOI) should be identified to optimise performance (Jayaram and Tan, 2010).

4.9 Engineering the performance of green-field architectures

Existing frameworks such as Kaplan and Norton (1996), which was expanded by Brewer and Speh (2000), are applicable to specific supply chain categories 'supply chain performance measures and integration' (SCPME). These frameworks are not applied to evaluate strategy architecture that can be defined as 'green-field performance measures' (GPM), where measuring performance in effect refers to forecasting performance. The most advanced performance measurement system identified is the SCOR model (SCC, 2001) because the model is applied to industry and has evolved through feedback from industry. However, in an uncertain market demand and continuous new product development, flexibility and feasibility should also be included in the performance measures (Perez-Franco et al., 2010).

4.10 Engineering the environmental dimensions for green-field architectures

Supply chain engineering must anticipate 'product and product family' (PF) in the design process, while supply chain architecture must be designed in accordance to the 'best product operating cost' (BPOC) (Liu and Hipel, 2012, Lo and Power, 2010, Lamothe et al., 2006). The supply chain design must anticipate 'design for environment', and 'design for disassembly' (DE-DD) (Clendenin, 1997). Supply chain strategy architecture should be focused on: (1) optimising the company strategy and service elements through 'postponement strategy and market demand' (PS-MD) (Korpela et al., 2001b); (2) the relationship between buyer and supplier in the 'strategy dimensions' (StD) (Van der Vaart and van Donk, 2008, Closs and Mollenkopf, 2004); (3) the supply chain functions must be based on the 'business environment' (BE); (5) the supply chain integration strategy must be based on the 'market and distribution planning' (MDP) strategies (Narasimhan and Kim, 2002).

5. FORMULATING THE METHODOLOGY

The taxonomic scheme applied, is aimed at addressing various problems emerging in formulating a

green-field supply chain strategy. These are critically appraised above, with specific observations against each approach, to identify limitations and areas applicable to designing a methodology for green-field supply chain strategy engineering. The taxonomy of literature resulted in identifying, categorising and cataloguing the main themes (Table 1) necessary for generating a new methodology.

The methodology is transcribed into a concept diagram (Figure 1), before the findings from the taxonomy of literature are summarised into building blocks, and drawn into diagram of problems related to practical aspects of supply chain engineering (Figure 2). The concept diagram and the building blocks are related to the identified gaps in existing literature.

The process of categorising, cataloguing and relating the key tenets from existing literature enabled the development of a new methodology (Figure 2 and Figure 3). The approach is compliant with Eisenhardt (1989), Glaser and Strauss (1967) and Yin (2009) guidance on theory building. The methodology contains different aspects, which interrelate to define and interpret the process of engineering a green-field supply chain integration strategy. Different aspects of the taxonomy are interrelated to define the methodology. Interrelated aspects are interpreted in the following building blocks.

In the supply chain engineering methodology, the architecture of a green-field project integration strategy is interpreted as: articulation of the external dimensions, elements, forces and factors out of the control of the business and supply chain strategy. The critical analysis of the factors and problems derived with emerging categories of external dimensions, elements, forces and factors.

The methodology interrelates the architecture, through evaluating salient dimensions in relation to the external elements, forces and factors. In the process of interrelating these aspects, different problems emerge from the salient dimensions in relation to the external elements, forces and factors. The taxonomy of approaches determined the importance of dimensions, elements, forces and factors in relation to key tenets for green-field strategy integration (Table 1).

The priority of the supply chain engineering methodology is placed on designing a method for systematic prioritising of activities towards green-field inte-

gration areas. The design aspect is defined through applying the key tenets (Table 1), to designing hierarchical concept map (Figure 1), for identifying and organising individual operational activities towards integrated supply chain strategy engineering.

The second aspect of the methodology is the designing of evaluation criteria for the integrated supply chain strategy. The priority of this aspect of the design was, to investigate how conflict of interests can be identified and eliminated. This was addressed through designing a diagram interrelating the con-

cepts that emerged from the taxonomy of approaches (Figure 2). The objective of the diagram was to enable supply chain participants to visualise individual business objectives and gaps in interrelating the supply chain strategy. The diagram should be interpreted in individual context of the supply chain scenario in accordance to the concepts defined in the taxonomy (Table 1). The design of conceptual diagram related to the specific supply chain scenarios, enables visualising individual activities and gaps in integration of supply chain operations, specific to individual supply chain activities.

Table 1: Taxonomy of key tenets for engineering a green-field supply chain integration strategy

Taxonomic Scheme			
<p>StD: Strategy Dimensions BE: Business environment ExD: External dimension SaD: Salient dimension GF: Greenfield supply chain Architecture SA: Strategy absence CS: Corporate strategy SCSA: Supply chain strategy articulation PAO: Participants aims and objectives</p>	<p>FE: Architecture Elements FCr: Architecture criteria NO: Networked organisation TC: Trust and commitment IOC: Interdependence and organisational compatibility IBC: Identification of best candidates CSCIOI: Conceptual supply chain inter-organisational integration</p>	<p>FCo: Architecture Concepts CE: Capabilities integration EE: External element EFa: External factor EFo: External force UF: Underlying factor FI: Architecture Implementation AA: Adapting and aligning OASA: ontological approach for semantic alignment</p>	<p>DSCHT: Decomposing supply chain into hierarchical three PR: process of getting from the present to the required stage CSSCD: Conceptual system for supply chain decomposition CF: Framework approach</p>
<p>PSaD: Preliminary salient dimensions PF: product and product family BPOC: best product operating cost DE-DD: design for environment and design for disassembly PS-MD: postponement strategy and market demand MDP: market and distribution planning</p>	<p>TLS: Transport and logistics strategy TLISE: transportation and logistics integration strategic elements SCA: supply chain agility SCPME: Supply chain performance measures and integration GPM: Greenfield supply chain performance measures</p>	<p>SCI: Supply chain integration OTA: Outsourcing through abstention FOI: fit, intensity and integration CEFE: Capture the essence and forecast the effect of supply chain integration and performance CGSI: Characterise Greenfield supply chain supply chain strategy and integration</p>	<p>BCAO: Barriers to change and approaches to overcome IMSC: integration as a method for integrating strategic choices STPC: Separation in space, time, parts and conditions PC-VC: Process chain and virtual eChain</p>

Principles emerging from the Taxonomic Scheme

The process of building methodology (Figure 2) is relying on a number of key tenets (Table 1) presented as supply chain engineering principles:

- » First principle: in supply chain architecture, to understand the companies’ real strategies the architecture must be interacting with the design (activities) (Sukati et al., 2012, Perez-Franco et al., 2010, Bozarth et al., 2009, Cigolini et al., 2004, Porter, 1996, Andrews, 1982).
- » Second principle: to understand how supply chains are designed, ‘tacit knowledge’ should be

considered as instrumental in distinguishing between the engineering the strategy and the design of the activities (Sukati et al., 2012, Perez-Franco et al., 2010).

- » Third principle: supply chain can be engineered as a conceptual system, where the architecture is based on a conceptual design (Melnyk et al. 2013, Perez-Franco et al., 2010, Bozarth et al., 2009).
- » Fourth principle: the supply chain activities are sufficient for conceptualising the architecture, design and engineering (Melnyk et al. 2013, Perez-

Franco et al., 2010, Bozarth et al., 2009, Cigolini et al., 2004).

- » Fifth principle: supply chain engineering contains architecture and design, where the engineering is the central idea of the external architecture and internal design (Perez-Franco et al., 2010), but the design is representative of the integrated objectives and the design determines the architecture (Melnyk et al. 2013, Narasimhan et al., 2008, Mentzer, 2001).
- » Sixth principle: the supply chain engineering relies on the integrated design and the design is based on the external architecture, but while the architecture is influenced, it is not determined by the integrated design (Nikulin et al. 2013, Sukati et al., 2012, Inkpen and Choudhury, 1995). The design represent a set of ideas incorporated in the engineering that; supplement, assist and enable the architecture (Melnyk et al. 2013, Perez-Franco et al., 2010, Martínez-Olvera, 2008, Schnetzler et al., 2007, Martínez-Olvera and Shunk, 2006).

The next step in interpreting and applying the taxonomic scheme (Table 1), was to design a conceptual framework diagram identifying the gaps in literature on engineering a green-field integration strategy (Figure 1). The conceptual framework

Defining the conceptual framework diagram and the methodology

The conceptual framework diagram (Figure 1) represents the supply chain architecture and integration design, and is based on supply chain activities identified in existing literature and presented in a taxonomic scheme (Table 1). The architecture and design relates the activities to the predetermined supply chain integration areas from the taxonomic scheme (Table 1). These are evaluated with combining the evaluation criteria from existing literature (Table 1) and interrelated to the conceptual framework (Figure 2).

Figure 1 represents the architecture and design, and the gaps that are identified in literature. Those gaps represent problems that could create negative effects on green-field supply chain engineering. Thus, they need to be addressed in a systematic process when engineering the green-field supply chain strategy. Figure 2 represents that systematic process for supply chain engineering, and should be interpreted as the process for interrelating the attitudes, practices and patterns present in existing literature. The full list of attitudes, patters, and practices is outlined in the taxonomic scheme (Table 1).

An important conclusion based on the taxonomic scheme (Table 1) is that there is little consensus on how to engineer green-field supply chain strategy integration, or on how to measure the effects of supply chain architecture on integration and performance. In Figure 1, we take this concern as a starting point to create a conceptual framework diagram from existing research studies on the topic of supply chain architecture and design. In the Figure 2, the findings derived from the taxonomic scheme (Table 1) are applied as a discussion focused on the interrelationships between the various supply chain strategic factors, on the relationship between supply chain architecture and design, and on the attitudes, practices and patterns that have an impact on supply chain engineering.

Examining the relationship between supply chain architecture and design, without concrete set of evaluation criteria of the interrelationships between the different supply chain engineering factors, seems inconclusive. Given the complex interactions between attitudes, patterns and practices, outlined in Table 1, it seems necessary to take into account these interactions when investigating the process of engineering supply chain architecture and design.

For example, one would anticipate an interaction between architecture (e.g. external elements, factors and forces) and practices (e.g. corporate strategy). Similarly, we would expect there to be a relationship between corporate strategy and the integrated business strategy.

Figure 1: Conceptual framework for engineering a green-field supply chain integration

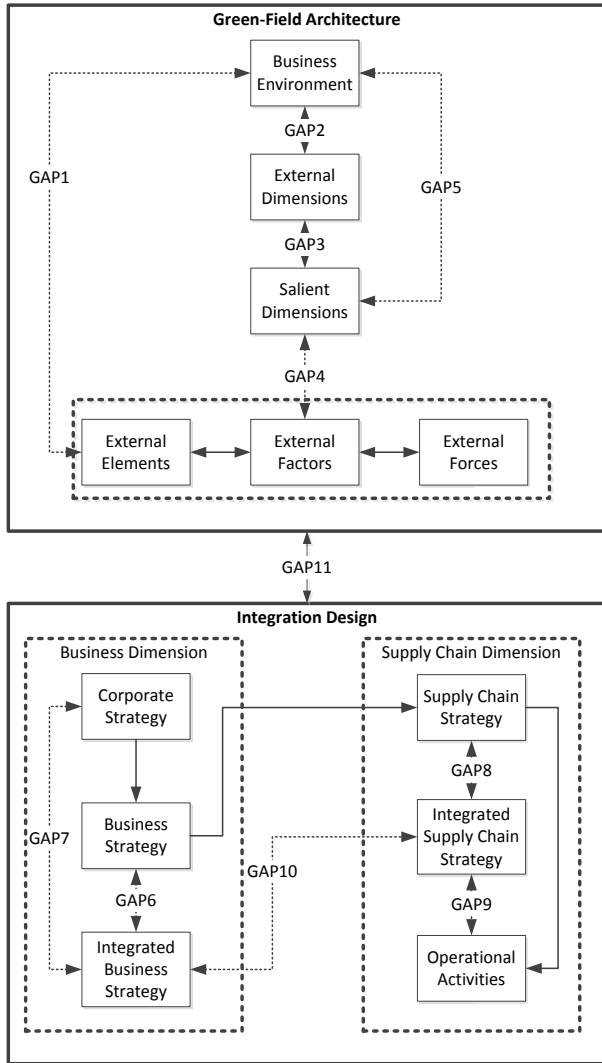
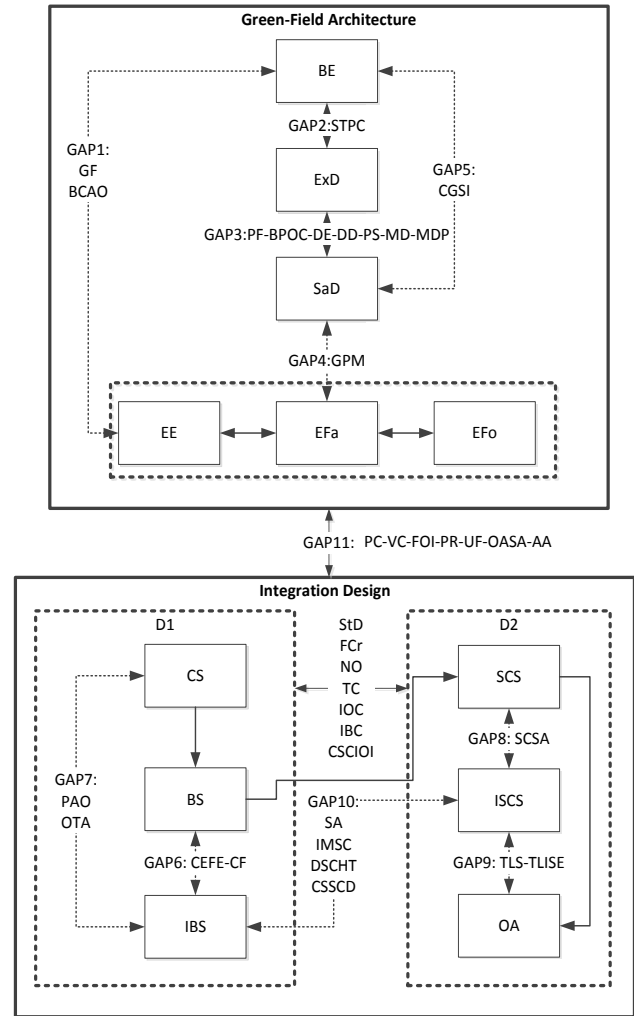

Figure 2: Methodology for engineering a green-field supply chain integration strategy



In line with the finding from the taxonomic scheme (Table 1), it seems logical, especially from a conceptual point of view, to focus on systematically engineering the holistic supply chain, by focusing on the interrelationship between supply chain architecture and integration design in individual context. Many authors instead focus on individual problems in individual context. It is not sufficient to have a solution to one problem and to ignore other supply chain problems. The objective of methodology (Figure 2) is to systematically address multiple problems in the same time.

The methodology (Figure 2) measures the interrelationships within a single relationship and then to relate the supply chain engineering of the architecture and design. The advantage of relating individual interrelationships is that it is relatively easy to acquire reliable, evaluation criteria for single interrelationship. By doing that, it becomes clearer about what is exactly being engineered (Figure 2) and interrelated to the multiple relationships (Table 1).

To ensure validity of these findings, the methodology is field tested with a case study of the Mining Industry. Before field testing the methodology, a set

of six principles are defined. The set of principles enable academics and practitioners to interrelate different aspects of the methodology and to help them in interpreting Table 1, Figure 1 and Figure 2.

Field testing the new methodology with a case study

The case study was performed on the Slate Mining Industry in North Wales (Figure 3), to formulate a green-field supply chain strategy, integrating the complete supply chain. The case study included a Slate Mining Quarry, Civil Engineering Company, Logistics Company, Rail Terminal Company, Wholesalers (Virtual Quarries) and Retailers (Gardening and Building Materials Shops). The final

result of the engineering is expressed in Figure 3, detailing how different aspect are interrelated in practice and interpreting the practical contributions from the methodology.

The supply chain engineering in the case study was performed by applying the methodology and assembling the Pugh controlled convergence (PuCC) conceptual design (Pugh, 1990), in combination with the mechanisms for capturing, evaluating and reformulating a supply chain strategy (Perez-Franco et al. 2010). These methods are applied in combination with: the supply chain design decomposition pyramidal arrangements (Schnetzler et al., 2007) and the engineering system dynamics for supply chain design (Hafeez et al., 1996).

Figure 3: Application of the methodology on the Slate Mining Industry in North Wales.

Practical Application of the Methodology for Engineering a Green-Field Supply Chain Architecture

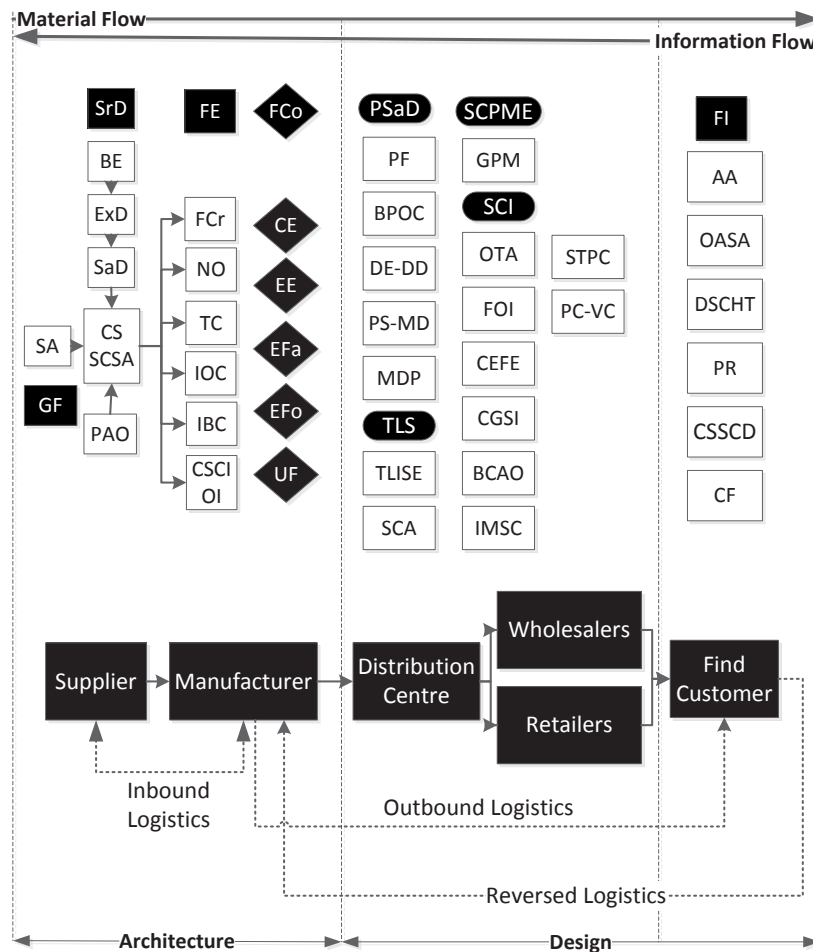

6. DISCUSSION AND IMPLICATIONS

The attention of many researchers outlined in this paper, has often focused on a single area of supply chain strategy. They have generally neglected research on the whole performance of the supply chain strategy engineering, which includes the architecture and design aspects. Considering these gaps, this paper established a methodology, which used the concept of strategic decision making levels and supply chain integration processes, as the approach to the study of the holistic supply chain strategy engineering. In the theory generation stages, the methodology was designed towards green-field strategy engineering for integrating multiple participants. The concept of green-field integration sets this apart from existing methods, which are designed to re-formulate existing strategies of individual companies.

The implications of this study are focused on the strategic operational activities, and on avoiding prescriptive and descriptive approaches, and addressed the operationalisation aspects of supply chain engineering. While validating the methodology with a case study, the methodology guided the development of integrated strategy, and addressed multiple supply chain complexities, which represented testing the theory in a real life phenomenon with multiple variables.

7. CONCLUSION

The paper revealed a new methodology for engineering, architecting, and designing integrated green-field supply chain. The methodology derived with the conclusion that green-field supply chain architecture, design and engineering represents a dynamic process, and should be analysed in individual contexts. The critical summary of literature reviewed resulted in identifying the main themes in a summary map (Table 1), necessary for generating a new methodology (Figure 1). The main themes are categorised in key tenants (Table 1). The key tenants are catalogued for addressing several problems present in engineering the architecture and design of green-field supply chains. These are critically appraised, with specific observations, to identify and catalogue the key tenants that function as principles for building the methodology.

The hierarchical method for network design was applied for building and combining the architecture, design and engineering criteria. This approach was supported with principles from DSCHT, and combined

with the techniques from ATC. The new principles contribute to knowledge with: (1) architecting the supply chain elements from multiple supply chain participants; (2) designing the participants' main aims and objectives, and (3) engineering the process of getting from the present to the required stage. The supply chain principles are also aimed at anticipating operational capabilities through internal competencies and by considering inter-organisational integration in combination with operations re-engineering.

The concept verification applied architecture and integration criteria as a method for strategy engineering. The new methodology enables building upon the supply chain engineering criteria that until present, has not been built upon and combined with the process engineering design criteria: visibility, acceptance, participation, communication, adaptability, integration, effectiveness, flexibility, and responsiveness. Combining the criteria represents a holistic approach for supply chain architecture and result in deriving new understandings of green-field supply chain engineering that can be applied by supply chain practitioners.

7.1 Limitations and future research

The methodology contributes to and enriches the existing literature and provides background for further academic research in this subject. However, this methodology was verified with a single case study on the mining industry, and while it is anticipated that the proposed methodology is suitable for other sectors, the findings would need to be delimited through further testing and research.

Further research is required into the topic of addressing strategy absence. In scenarios of high strategy absence the engineering and evaluation criteria of this methodology would be difficult to implement. In that respect, the main challenge for future research is in extracting supply chain strategy tacit knowledge and converting it into explicit. There is a strong preference in practice towards desired over feasible objectives. This issue becomes one of a degree in an integration, because of avoidance of criticism, conflict, disagreement, and controversy. Future research studies should be aware that these challenges.

8. References

- Abdur Razzaque, M., and Chen Sheng, C. (1998). Outsourcing of logistics functions: a literature survey. *International Journal of Physical Distribution and Logistics Management*, 28(2), pp.89–107.

- Al-Mudimigh, A. S., Zairi, M., and Ahmed, A. M. M. (2004). *Extending the concept of supply chain: The effective management of value chains*. *International Journal of Production Economics*, 87(3), pp.309–320.
- Andrews, K. R. 1982. *The Concept of Corporate Strategy*. In C.R. Christensen, K. R. Andrews, J. L. Bower, R. G. Hamermesh And M. E. Porter (Eds.), *Business Policy: Text And Cases*, Irwin, Homewood, IL.
- Andrews, R. B., George A. Law, J. W., Richard, M., (2009). *Strategy Formulation, Strategy Content and Performance: An Empirical Analysis*. *Public Management Review*, 11, pp.1-22.
- Beamon, B.M., 1998. *Supply Chain Design and Analysis: Models and Methods*. *International Journal of Production Economics*, 55(3), pp. 281–294
- Bogataj, M., and Bogataj, L. (2001). *Supply chain coordination in spatial games*. *International Journal of Production Economics*, 71(1-3), pp.277–285.
- Bozarth, C.C., Warsinga, D.P., Flynn, B.B., Flynn, E.J., 2009. *The impact of supply chain complexity on manufacturing plant performance*. *Journal of Operations Management*, 27(1), pp.78–93.
- Brewer, P. C., and Speh, T. W. (2000). *Using the balanced scorecard to measure supply chain performance*. *Journal of Business Logistics*, 21(1), 75–94.
- Childerhouse, P., and Towill, D. R. (2011). *Arcs of supply chain integration*. *International Journal of Production Research*, 49(24), pp.7441–7468.
- Cigolini, R., Cozzi, M., and Perona, M. (2004). *A new framework for supply chain management*. *International Journal of Operations and Production Management*, 24(1), pp.7–41.
- Clausing, D. (1992). *Enhanced quality function deployment (EQFD)*. [Cambridge, Mass.] : Massachusetts Institute of Technology, MIT Center for Advanced Engineering Study, MIT Press.
- Cledenin, J. A. (1997). *Closing the Supply Chain Loop: Reengineering the Returns Channel Process*. *The International Journal of Logistics Management*, 8(1), pp. 75–86.
- Closs, D. J., and Mollenkopf, D. A. (2004). *A global supply chain framework*. *Industrial Marketing Management*, 33(1), pp.37–44.
- Dotoli, M. Fanti, M. P., Melonia., and Zhou, M.C., 2007. *A multi-level approach for network design of integrated supply chains*. *International Journal of Production Research*. 43 (20), pp 4267-4287
- Dubois, A., Hulthén, K., and Pedersen, A.C. (2004). *Supply chains and interdependence: a theoretical analysis*. *Journal of Purchasing and Supply Management*, 10(1), pp.3–9.
- Eisenhardt, K. M. (1989). *Building Theories From Case Study Research*. *Academy Of Management Review*, 14(4), pp. 532-550.
- Eppinger, S. D., Whitney, D. E., Smith, R. P., and Gebala, D. A. (1994). *A model-based method for organizing tasks in product development*. *Research in Engineering Design*, 6(1), pp.1–13.
- Frohlich, M. and Westbrook, R., 2001. *Arcs of Integration: An International Study of Supply Chain Strategies*. *Journal of Operations Management*. 19 (2001), pp. 185–200.
- Gilley, K. M., and Rasheed, A. (2000). *Making More by Doing Less: An Analysis of Outsourcing and its Effects on Firm Performance*. *Journal of Management*, 26(4), pp.763–790.
- Glaser, B. S., and Stauss, A.L. (1967). *The Discovery of Grounded Theory*, London, Weidenfeld & Nicolson.
- Griffis, S. E., Bell, J. E., and Closs, D. J. (2012). *Metaheuristics in Logistics and Supply Chain Management*. *Journal of Business Logistics*, 33(2), pp.90–106.
- Hafeez, K., Griffiths, M., Griffiths, J., and Naim, M. M. (1996). *Systems design of a two-echelon steel industry supply chain*. *International Journal of Production Economics*, 45(1-3), pp.121–130.
- He, Y., and Lai, K. K. (2012). *Supply chain integration and service oriented transformation: Evidence from Chinese equipment manufacturers*. *International Journal of Production Economics*, 135(2), pp.791–799.
- Hipel, K. W. (2012). *A Hierarchical Decision Model to Select Quality Control Strategies for a Complex Product*. *IEEE Transactions on Systems, Man, and Cybernetics - Part A: Systems and Humans*, 42(4), pp.814–826.
- Inkpen, A., and Choudhury, N. (1995). *The seeking of strategy where it is not: Towards a theory of strategy absence*. *Strategic Management Journal*, 16(4), pp.313–323.
- Ivanov, D. (2010). *An adaptive framework for aligning (re)planning decisions on supply chain strategy, design, tactics, and operations*. *International Journal of Production Research*, 48(13), pp.3999–4017.
- Jayaram, J. and Tan, K.C., 2010. *Supply Chain Integration with Third-Party Logistics Providers*. *International Journal of Production Economics*, 125 (2), pp. 262–271.
- Kaplan, R. and Norton, D., 1996. *Using the balanced scorecard as a strategic management system*. *Harvard Business Review*, 74 (1), pp. 75-85
- Kim, D. (2006). *Process chain: A new paradigm of collaborative commerce and synchronized supply chain*. *Business Horizons*, 49(5), pp.359–367.
- Korpela, J., Lehmusvaara, A., and Tuominen, M. (2001). *An analytic approach to supply chain development*. *International Journal of Production Economics*, 71(1-3), pp.145–155.
- Korpela, J., Lehmusvaara, A., Tuominen, M., Lamothe, J., Hadj-Hamou, K., Aldanondo, M., Siferd, S. P. (2001). *Customer service based design of the supply chain*. *International Journal of Production Economics*, 69(2), pp.193–204.
- Lamothe, J., Hadj-Hamou, K., and Aldanondo, M. (2006). *An optimization model for selecting a product family and designing its supply chain*. *European Journal of Operational Research*, 169(3), pp.1030–1047.
- Lee, H. and Billington, C., (1992). *Managing supply chain inventory: pitfalls and opportunities*. *Sloan management review*, 33(3), pp.64–73.
- Lertpattarapong, C. (2002). *Applying System Dynamics Approach to the supply chain management problem*, MSc Thesis, Massachusetts Institute of Technology, MIT Press.

- Lee, H., Padmanabhan, V. and Whang, S., (1997). The bullwhip effect in supply chains1. *Sloan management review*, 38(3), pp.93–102.
- Lo, S. M., and Power, D. (2010). An empirical investigation of the relationship between product nature and supply chain strategy. *Supply Chain Management: An International Journal*, 15(2), pp.139–153.
- Manthou, V., Vlachopoulou, M., and Folinas, D. (2004). Virtual e-Chain (VeC) model for supply chain collaboration. *International Journal of Production Economics*, 87(3), pp. 241–250.
- Martínez-Olvera, C. (2008). Methodology for realignment of supply-chain structural elements. *International Journal of Production Economics*, 114(2), pp.714–722.
- Martínez-Olvera, C., and Shunk, D. (2006). Comprehensive framework for the development of a supply chain strategy. *International Journal of Production Research*, 44(21), pp.4511–4528.
- Mckone-Sweet, K., and Lee, Y.T. (2009). Development and Analysis of a Supply Chain Strategy Taxonomy. *Journal of Supply Chain Management*, 45(3), pp.3–24.
- Melnyk, S. A., Narasimhan, R., and DeCampos, H. A. (2013). Supply chain design: issues, challenges, frameworks and solutions. *International Journal of Production Research*, 52(7), pp.1887–1896.
- Menda, R. and Dilts, D., (1997). The manufacturing strategy formulation process: linking multifunctional viewpoints. *Journal of Operations Management*, 15(4), pp.223–241.
- Mentzer, J.T., DeWitt, W., Keebler, J.S., Min, S., Nix, N.W., Smith, C.D., Zacharia, Z.G. (2001). *Defining Supply Chain Management*. *Journal of Business Logistics*, 22(2), pp.1–25.
- Miller, D. and Friesen, P.H., 1978. Archetypes of Strategy Formulation. *Management Science*, 24(9), pp.921–933.
- Narasimhan, R., Kim, S.-W. and Tan, K.-C., 2008. An Empirical Investigation of Supply Chain Strategy Typologies and Relationships to Performance. *International Journal of Production Research*, 46(18), pp.5231 – 5259.
- Nikulin, C., Graziosi, S., Cascini, G., Araneda, A., and Minutolo, M. (2013). An Algorithm for Supply Chain Integration based on OTSM-TRIZ. *Procedia - Social and Behavioral Sciences*, 75, pp.383–396.
- Pathak, S. D., Day, J. M., Nair, A., Sawaya, W. J., and Kristal, M. M. (2007). Complexity and adaptivity in supply networks: building supply network theory using a complex adaptive systems perspective. *Decision Sciences*, 38(4), pp.547–580.
- Perez – Franco, R. J, Sheffi, Y. Silbey, S., Frey, D., Singh, M., Leveson, N. 2010. A methodology to capture, evaluate and reformulate a firm's supply chain strategy as a conceptual system. PhD Thesis, MIT Press
- Platts, K., Mills, J. and Neely, A., (1996). Evaluating manufacturing strategy formulation processes. *International Journal of Production Economics: Proceedings of the 8th International Working Seminar on Production Economics*, 46-47, pp. 233–240
- Porter, M. (1996). What is Strategy? *Harvard Business Review*, 61-78.
- Pugh, S. (1990). Total Design: Integrated Methods for Successful Product Engineering, Addison-Wesley Wokingham, UK.
- Radanliev, P., (2015a) 'Green-field Architecture for Sustainable Supply Chain Strategy Formulation', *International Journal of Supply Chain Management*, 4(2), pp.62-67.
- Radanliev, P., (2015b) 'Supply Chain Systems Architecture and Engineering Design: Green-field Supply Chain Integration' *Operations and Supply Chain Management: An International Journal*, 9(1), pp. 22-30.
- Radanliev, P., (2015c) 'Architectures for Green-Field Supply Chain Integration: Supply Chain Integration Design', *Journal of Supply Chain and Operations Management*, 13(2), pp.56-78.
- Qu, T., Huang, G. Q., Cung, V.-D., and Mangione, F. (2010). Optimal configuration of assembly supply chains using analytical target cascading. *International Journal of Production Research*, 48(23), pp.6883–6907.
- Qureshi, M. N., Kumar, P., and Kumar, D., 2009. Selection of Transportation Company: An Analytic Network Process Approach. *Icfai Journal of Supply Chain Management*, 6(2), pp.26-38.
- Rao, P., and Holt, D. (2005). Do green supply chains lead to competitiveness and economic performance? *International Journal of Operations and Production Management*, 25(9), pp.898–916.
- Rosenzweig, E. D., Roth, A. V, and Dean, J. W. (2003). The influence of an integration strategy on competitive capabilities and business performance: An exploratory study of consumer products manufacturers. *Journal of Operations Management*, 21(4), pp.437–456.
- Saad, M., Jones, M., and James, P. (2002). A review of the progress towards the adoption of supply chain management (SCM) relationships in construction. *European Journal of Purchasing and Supply Management*, 8(3), pp.173–183.
- Sakka, O., Millet, P.-A., and Botta-Genoulaz, V. (2011). An ontological approach for strategic alignment: a supply chain operations reference case study. *International Journal of Computer Integrated Manufacturing*, 24(11), pp.1022–1037.
- Sc. (2001). Supply-Chain Operations Reference-Model. Pittsburgh: Supply Chain Council, Inc., Retrieved From The World Wide Web: [Http://www.Supply-Chain.Org](http://www.supply-chain.org).
- Schnetzler, M. J., Sennheiser, A., and Schönsleben, P. (2007). A decomposition-based approach for the development of a supply chain strategy. *International Journal of Production Economics*, 105(1), pp. 21–42.
- Shah, J., and Singh, N. (2001). Benchmarking Internal Supply Chain Performance: Development of a Framework. *The Journal of Supply Chain Management*, 37(1), pp.37–47.
- Sheffi, Y., (1990). Third party logistics: present and future prospects. *Journal of Business Logistics*, 11(2), pp.27–39.
- Sheu, D. D., and Lee, H.-K. (2011). A proposed process for systematic innovation. *International Journal of Production Research*, 49(3), pp.847–868.
- Soni, G., and Kodali, R. (2010). Internal benchmarking for assessment of supply chain performance. *Benchmarking: An International Journal*, 17(1), pp.44–76.

- Sukati, I., Hamid, A. B., Baharun, R., and Yusoff, R. M. (2012). The Study of Supply Chain Management Strategy and Practices on Supply Chain Performance. *Procedia - Social and Behavioral Sciences*, 40, pp.225–233.
- Swink, M., Narasimhan, R., and Wang, C. (2007). Managing beyond the factory walls: Effects of four types of strategic integration on manufacturing plant performance. *Journal of Operations Management*, 25(1), pp.148–164.
- Tracey, M., Vonderembse, M. A., and Lim, J.S. (1999). Manufacturing technology and strategy formulation: keys to enhancing competitiveness and improving performance. *Journal of Operations Management*, 17(4), pp.411–428.
- Van der Vaart, T., and van Donk, D. P. (2008). A critical review of survey-based research in supply chain integration. *International Journal of Production Economics*, 111(1), pp.42–55.
- Van Donk, D. P., and van der Vaart, T. (2005). A case of shared resources, uncertainty and supply chain integration in the process industry. *International Journal of Production Economics*, 96(1), pp.97–108.
- Vickery, S. K., Jayaram, J., Droge, C., and Calantone, R. (2003). The effects of an integrative supply chain strategy on customer service and financial performance: an analysis of direct versus indirect relationships. *Journal of Operations Management*, 21(5), pp.523–539.
- Yin, R. K. 2009. *Case study research: Design and methods*, Sage Publications, Inc.
- Zhou, S., and Chen, R. (2001). A decision model for selecting participants in supply chain. *Journal of Shanghai University (English Edition)*, 5(4), pp.341–344.
- Zsidisin, G. A., and Siferd, S. P. (2001). Environmental purchasing: a framework for theory development. *European Journal of Purchasing and Supply Management*, 7(1), pp.61–73.

Author's Biography:

Petar Radanliev is a Postdoctoral Research Fellow at Anglia Ruskin University in Cambridge. Dr Radanliev holds a Ph.D. in Technology from the University of South Wales, MSc (Econ) and BA (Hons) from University of Wales, Aberystwyth.