

Tagat, Anirudh; Kapoor, Hansika

**Working Paper**

## The trust broker game: A three-player trust game with probabilistic returns and information asymmetry

Economics Discussion Papers, No. 2017-33

**Provided in Cooperation with:**

Kiel Institute for the World Economy – Leibniz Center for Research on Global Economic Challenges

*Suggested Citation:* Tagat, Anirudh; Kapoor, Hansika (2017) : The trust broker game: A three-player trust game with probabilistic returns and information asymmetry, Economics Discussion Papers, No. 2017-33, Kiel Institute for the World Economy (IfW), Kiel

This Version is available at:

<https://hdl.handle.net/10419/162574>

**Standard-Nutzungsbedingungen:**

Die Dokumente auf EconStor dürfen zu eigenen wissenschaftlichen Zwecken und zum Privatgebrauch gespeichert und kopiert werden.

Sie dürfen die Dokumente nicht für öffentliche oder kommerzielle Zwecke vervielfältigen, öffentlich ausstellen, öffentlich zugänglich machen, vertreiben oder anderweitig nutzen.

Sofern die Verfasser die Dokumente unter Open-Content-Lizenzen (insbesondere CC-Lizenzen) zur Verfügung gestellt haben sollten, gelten abweichend von diesen Nutzungsbedingungen die in der dort genannten Lizenz gewährten Nutzungsrechte.

**Terms of use:**

*Documents in EconStor may be saved and copied for your personal and scholarly purposes.*

*You are not to copy documents for public or commercial purposes, to exhibit the documents publicly, to make them publicly available on the internet, or to distribute or otherwise use the documents in public.*

*If the documents have been made available under an Open Content Licence (especially Creative Commons Licences), you may exercise further usage rights as specified in the indicated licence.*



<http://creativecommons.org/licenses/by/4.0/>

## The trust broker game: a three-player trust game with probabilistic returns and information asymmetry

*Anirudh Tagat and Hansika Kapoor*

### Abstract

This paper experimentally investigates trust and trustworthiness in a repeated and sequential three-player trust game with probabilistic returns and information asymmetry. It adds to the existing literature by combining experimental features from recent work in the trust game. The authors use random variations in the multiplier value, a third player without an initial endowment, undisclosed termination rules, and variations in information availability related to transactions. The framework is novel in that the game continues even if the first player transfers no amount to the second player. Using participants from India, the results are broadly consistent with past evidence on the trust game. All players are more trusting when information of their transfers and earnings are made available to other players. The third player (termed the "trust broker") transfers a larger amount when information on transfers is disclosed to other players. The authors find that information availability leads to a significant increase in the trust broker's reciprocity, as defined by the amount that is returned to Player 2. Social desirability, cultural contexts, and learning effects are discussed in terms of scope for future research.

**JEL** C91 C92 D64 D70

**Keywords** Trust game; multi-level games; uncertainty; trustworthiness; selfishness; reciprocity

### Authors

*Anirudh Tagat*, ✉ Monk Prayogshala, Mumbai, India, [at@monkprayogshala.in](mailto:at@monkprayogshala.in)

*Hansika Kapoor*, Department of Psychology, Monk Prayogshala, Mumbai, India

*We thank two anonymous referees for comments on earlier drafts of the paper and Jonathan Schulz for valuable suggestions. We also thank Ritu Dewan for allowing us to run experiments at the Department of Economics, Mumbai University, Khushboo Balani and Avantika Sharma for assistance in data collection, and Sharanya V. for assistance with data analysis.*

**Citation** Anirudh Tagat and Hansika Kapoor (2017). The trust broker game: a three-player trust game with probabilistic returns and information asymmetry. Economics Discussion Papers, No 2017-33, Kiel Institute for the World Economy. <http://www.economics-ejournal.org/economics/discussionpapers/2017-33>

## **The Trust Broker Game: A Three-player Trust Game with Probabilistic Returns and Information Asymmetry**

Trust and trustworthiness are at the core of understanding social preferences among economic agents. In recent years, there has been extensive focus on extending the nature and dynamics of the trust game originally proposed by Berg, Dickhaut, and McCabe (1995). Trust in this framework is measured by the amount of transfer as a proportion of their initial endowment, while trustworthiness is defined by the amount of transfer returned as a proportion of the amount available to return. An extensive review of the literature suggests several generalizable findings from the experiment (Johnson and Mislin 2011). First, players sent, on average, half of their initial endowment, and were returned a little more than one-thirds of the other players' available funds. This is a consistent indication of rejection of the standard assumption of rationality and self-interest, even though the actual amounts that were sent and received are known to vary widely. Second, the value of the multiplier that determines returns to trust varies significantly with the amounts sent, suggesting that this factor is crucial to understanding behaviour. Last, there is strong evidence that geography and culture has a significant role to play in outcomes of the trust game. For example, trust and trustworthiness in studies conducted in Africa and South America were at much lower levels than their counterparts in North America and Europe. These findings suggest that even minor changes in experimental design or protocol can affect trust behaviour.

In the present framework of the trust game, there is no option that allows for reciprocal behaviour, without trust being initiated by the first-mover. For instance, without the first-mover transferring a positive amount to the trustee, there is no scope for the second-mover to create an impression that he/she is trustworthy. Thus, one is unable to infer conditional or unconditional kindness (McCabe, Rigdon, and Smith 2003) on the part of the second-mover, *without* first assessing conditional or unconditional kindness on the part of the

first-mover.<sup>1</sup> In a sequential trust game with multiple players, this can be relaxed by allowing for the continuation of the game, even if the first-mover transfers nothing. Here, the (endowed) second-mover can display trust to a third player, who can reciprocate it by displaying trustworthiness to the second player. Then, the second-mover can choose to display trustworthiness (motivated by conditional or unconditional kindness) to the first-mover. To further dispute the implicit assumption of no trustworthiness without trust, it is essential to provide a choice to the second-mover to initiate trust and trustworthiness (without being trusted first). This is because conditional or unconditional kindness by the second-mover may precede conditional or unconditional kindness from the first-mover, as a signal of reciprocity being motivated by other-regarding or self-regarding preferences.<sup>2</sup>

One scenario in which such a game might be important is that of financial market transactions. Consider the case where an investor seeking to invest funds in a financial market instrument must do so via an intermediary, typically a broker. An investor relies on the broker to invest in a portfolio of instruments that provide high returns, for which the broker extracts a commission. Our laboratory experiment set up corresponds to a case where a potential investor's decision to invest in a financial market (e.g. a stock market) is mediated by a broker. The investment decision (similar to that of a trust game) is extended here to understand how trust and trustworthiness may vary when there are uncertain returns, information asymmetry, and a mediating player (i.e. the broker).

This paper aimed to contribute a novel experimental approach to understanding trust, trustworthiness, and reciprocity, when the initiation of trust was distributed between the first and second player. Our study is an extension of the original investment game that introduces variables that allow for asymmetric information and uncertain returns (similar to financial

---

<sup>1</sup> Brülhart and Usunier (2012) argued that trustors making a transfer to trustees may be motivated by selfishness, to gain more from the trustee's returned amount. This could be considered as second-order selfishness, as the trustor must first *trust* to be self-interested.

<sup>2</sup> The Faith game (Kiyonari et al. 2006) provided a similar set-up where the second-mover assumed the role of a dictator, therefore altering the trustor-trustee framework of the trust game.

investment scenarios) and other players to initiate trust. Hence, we call this game the Trust Broker Game (TBG, henceforth), where the third player acts as an intermediary with no initial endowment who can facilitate or blunt trusting and trustworthiness in the game. Three conditions were extended: (a) instead of a constant multiplier factor of 3, a variable multiplier (randomly taking values of 1 to 3) was used (similar to Güth et al. 2014); (b) a third player multiplied the amounts exchanged in the course of the game (similar to Rietz et al. 2013); and (c) information availability in transfers made by all three players, to incorporate information asymmetries (similar to Anderhub, Engelmann, and Güth 2002).

A constant multiplier of 3 (or another number) in the trust game makes the returns deterministic in nature, as opposed to uncertain returns that often characterize financial markets. This is because the experimenter guarantees that the amount transferred from A to B in the trust game is tripled before B receives the money. Hence, to mimic uncertain market conditions, the experimenter's deterministic stance must be replaced by uncertainty. Güth, Muegera, Musau, and Ploner (2014) found that uncertain environments (such as when payoffs are randomly determined) reduced reciprocity in trust games. Similarly, Vranceanu, Sutan, and Dubart (2012) modelled the consequences of "Nature" interfering with the investment game. Here, if trustors decided to send money to trustees, Nature mediated randomly by allowing the transaction to continue or not. This allowed the trustee to defect by violating trust and hiding behind the possibility that Nature ended the transaction. Nature represents a third player, whose decisions were unknown to the trustor, allowing the trustee to defect. Although such a game sampled selfishness accurately and introduced randomness in whether the game continued, Nature was only nominally a third entity, and the game did not represent multi-level trust. However, the game showed whether and when trust could break down in such relationships, owing to self-interested behaviours from the trustee, especially in financial trades with brokers.

It is also important to consider recent multi-level variations of the trust game. Sheremeta and Zhang (2013) introduce a sequential three-player trust game, where A may invest in B, who in turn, may invest in C. In each transfer, the amounts are tripled; C then makes transfers to A and B. Thus, A displays direct trust in B and indirect trust in C. On the other hand, C may display trustworthiness to both A and B. This variation endowed the three players equally, but the standard termination rule implied that the initiation of trust was unique to the first-mover—a feature of the design we extend in this study to the second-mover. Another multi-level trust game by Rietz et al. (2013) followed the sequential setup of having A (investor) trust B (intermediary), who then trusts C (borrower). Consistent with most experimental variations of the trust game, all amounts are tripled before they reach the trustee. The sequence of return moved from C to B to A, unlike Sheremeta and Zhang (2013). Thus, C might display direct trustworthiness to B, while B might display trustworthiness to A. Again the sequential set-up implies that only the first-mover could produce trust at the start of the game. While the trust game inflated the amount that was available for return due to a constant multiplier, both these experiments multiply transfer amounts *twice*, potentially inflating trust and trustworthiness.

Given the existence of deterministic returns and termination of the game, trust and trustworthiness therefore appear to be generated in an environment of high certainty. Similar multi-player trust games (e.g. Bigoni et al. 2013; Bauernschuster, Falck, and Große 2013) attempt to split the trustworthiness or trusting decision among two players, but retain a fixed multiplier value and sequential play between the three players. Recent research has investigated the implications of playing the trust game, either on behalf of others (“clients”; Kvaløy and Luzuriaga 2014) or with other people’s money (Jones 2013). When studied in the context of a multi-level trust game, such ‘brokering’ could enable an understanding of the decisions individuals made when not handling their own resources. In addition to introducing

a third player (Player C), randomizing multiplier values at one transaction point (B to C) serves to mimic uncertain market conditions where investor A trusts intermediary B to gain returns from broker C. As the multiplier is random, trusting and trustworthy behaviour can be elicited in the absence of guaranteed returns, for the trustors and trustees.

Finally, information asymmetry often influences strategies in games in conjunction with existing reputation effects arising out of repeated play. Lunawat (2013) describes two types of information treatments where reputation effects are reversed when disclosure was voluntary under specific experimental protocols. Since trustees have an incentive to mimic a trustworthy player, the trustor faces the problem of identifying a *consistently* trustworthy trustee. This was assessed by updating the probability beliefs in trustors and trustees. However in this set-up, disclosure was voluntary, while the TBG did not leave the option of disclosure to players. Other studies focussing on information asymmetry, such as Charness, Du, and Yang (2011) showed an incidence of indirect reciprocity, which implied that information on past transfers significantly influenced contemporaneous transfers in the game. They find that providing a history of returns and trusting behaviour greatly induced trust among players; a finding that will be tested in the presence of probabilistic returns and multiple players. Our paper is novel in that it jointly incorporates three important extensions in the trust game framework to improve the study of trustworthiness in a probabilistic-return setting with information asymmetry and multiple players. This is an important context to study trust and trustworthiness since it adds uncertainty to the decision-making framework, similar to financial markets where transactions often involve intermediaries. To the best of our knowledge, there has been little study of how these three independent features may interact with each other in a repeated-play setting.

The current work introduced the TBG and evaluated the transactions between the three players under varying information conditions. We are specifically interested in: (a)

What is the role of information availability on trust and trustworthiness between three players when returns were probabilistic? (b) What would be the effect of the random multiplier on amounts transacted between the three players? (c) Further, would information asymmetries and reputational concerns jointly interact with the multiplier value to influence decisions? (Johnson & Mislin, 2011)

Our key finding is that information availability significantly influences levels of trust and trustworthiness in the set-up of the Trust Broker Game. This is particularly the case for player C, who does not have any initial endowment. When the value of the multiplier is randomly determined, a higher multiplier was associated with player C retaining a larger proportion of the available endowment. Regression analyses show that for a given level of return, information availability is more likely to result in a higher level of reciprocal behaviour for player C than in the case where no information was available. This suggests that C returned a higher amount of available endowment when all transfers or earnings were observable. Our results show that in an environment of uncertain returns, a third player is less likely to reciprocate trust, unless all actions were observable by other players.

The rest of the paper is organized as follows. Section 2 describes the set-up of the Trust-Broker Game and contrasts it with the original trust game of Berg et al. (1995). Section 3 outlines the experimental design to implement the set-up. We then describe the key results from manipulating information availability and introducing uncertain environments. Section 4 concludes and outlines areas for future research.

### **The Trust Broker Game Setup**

Consider a three-player repeated investment game, which proceeds as follows (Figure 2): In the first stage, Player A decides what portion of her initial endowment ( $M_a$ ) to send to Player B (who has an endowment of  $M_b$ ). We denote the amount sent by player  $i$  to



player  $j$  is denoted by  $M_j^i$ , where  $M_j^i \in \{0, 1, 2, \dots, 10\}$ . At the end of stage one, the payoffs are  $P_a^1 = M_a - M_b^a$  and  $P_b^1 = M_b + M_b^a$  for Players A and B, respectively. In the second stage, Player B decides to transfer a portion from  $P_b^1 \in \{0, 1, \dots, P_b^1\}$  to Player C, who is designated as the broker.<sup>3</sup> The broker label follows from the conditions that (i) C has no initial endowment ( $M_c = 0$ ), and (ii) the transferred amount is *multiplied* at the time of transfer to Player C. These conditions are imposed to provide an incentive for C to be trustworthy in a repeated-game setting and maintain a reputation of being trustworthy. All the earnings of C are therefore contingent on the trust-trustworthiness dynamic with B. The multiplier is a random number  $k \in \{1, 2, 3\}$ <sup>4</sup> and thus results in a transfer  $M_c^b \cdot k$  for Player C. At the end of the second stage, the payoffs for Players B and C are  $P_b^2 = P_b^1 - M_c^b$  and  $P_c^2 = M_c^b \cdot k$ , respectively. The multiplied transfers are henceforth referred to as dividends.

### Figure 1 here

At the start of stage three, Player C decides to transfer a portion of  $P_c^2$  such that  $M_b^c \geq M_c^b$ . Any  $M_b^c$  selected by C must be at least the amount that he<sup>5</sup> received from B. This restriction is put in place to ensure continuity of the game.<sup>6</sup> However, C has the choice of either keeping the remaining amount from the dividend for himself or reciprocating B's trust (if any). Thus, there are two distinct strategies for C; for convenience, the two cases are  $M_b^c = M_c^b$  (returns exactly the amount sent to him by B), and  $M_b^c > M_c^b$ . Thus, the payoff for Player C at the end of stage three is  $P_c^3 = M_c^b \cdot k - M_b^c$  and for Player B at the end of stage three is  $P_b^3 = P_b^2 + M_b^c$ . Finally, in stage four, Player B decides whether to return part of her

<sup>3</sup> In the experimental setting, Player C was not identified as the 'broker' to prevent framing effects.

<sup>4</sup> The multiplier was the prevailing market condition. For example, no significant return is when  $k_c = 1$ , and highest possible return is when  $k_c = 3$ . Zero was not added as a random value, since it would represent an unforeseen loss, and is not incentive-compatible (Berg et al., 1995). 1 represented the baseline, wherein no additional money was generated.

<sup>5</sup> To distinguish between the broker and the players, 'he' was used for Player C only.

<sup>6</sup> Consider the case where C can return less than the amount he receives from B, such that  $M_b^c < M_c^b$ . Taken together with the fact that C is the only player without an initial endowment, we stipulate an exogenous level of trustworthiness (say, a 'market' level of trustworthiness) that must be adhered to, without which any additional trustworthiness cannot be generated.

payoff to Player A. Thus,  $M_a^b \in \{0, 1, \dots, P_b^3\}$  is the amount transferred at the end of the first round of the trust-broker game. At the end of the first iteration of the game, the payoffs for each player are defined as below:

$$P_a^4 = M_a - M_b^a + M_a^b \quad (1)$$

$$P_b^4 = P_b^3 - M_a^b \quad (2)$$

$$P_c^4 = P_c^3 \quad (3)$$

This differs from the trust game by introducing a broker as Player C, who is required to function as the multiplier according to given rules. Player C's role is to multiply the amount given by B based on random market conditions, hopefully receive a return on the principal, perhaps return a higher amount to B, and most likely gain a commission. This allows the study of player C's reciprocity (amount returned over the principal) and selfishness (amount retained over the principal), in addition to trust and trustworthiness. As with the original trust game, it is rational for players A and B to make zero transfers to their respective recipients. Despite all players being better off from any nonzero transfers (and particularly so in the case of CB), the risk of trust going unreciprocated is considered relative to the benefit from trusting.

Similar to the trust game, the AB and BC dyads represent trust<sup>7</sup>, while the CB and BA dyads represent trustworthiness. However, in the original trust game, Player A is the unique producer of trust at the start of the game, by deciding the quantum of money that is transferred to Player B, even though the money is multiplied without any effort expended by Player A. Therefore, there is a direct assessment of the trust that Player A displays in B and the trustworthiness that B displays in A. However, in the TBG, Player A (as a first-mover) is no longer the origin of trust at the start of the game; Player B (owing to her initial

---

<sup>7</sup> At the very minimum, C must return the principal, and this may be mediated by concerns of equity, since C gains at least as much as what was transferred to him, except in the case where the multiplier is 1, where he gains nothing.

endowment) can also choose to trust C, produce wealth, and then return some  $M_a^b > 0$  in the first round as a signal of her trustworthiness. See the lower nodes in Figure 1 for a representation of how the game proceeds when B initiates trust in the game without A's trust in B.

Since Player A is aware of the broker, the AB dynamic changes, and the BC dyad begins to function like the AB dyad in the trust game. That is, B displays trust in C, to multiply the money, and C displays trustworthiness in B, by returning B's principal, presumably with a surplus to show reciprocity. Player C can also give the entire multiplied amount to B, to display trustworthiness, in order to receive a larger transfer from B in the next round. By introducing the broker, B's trustworthy behaviour toward A may change, as compared to the original trust game. This can be attributed to the extended decision space of B, where she must choose not only a level of 'trustworthiness' (toward A) but also a level of 'trust' (toward C). Therefore, by introducing an element of selfishness external to both primary players, by means of the broker in the trust game, the game provides more opportunities for selfish behaviour in an uncertain environment.

### **Experimental Procedures and Results**

We manipulate information availability in three ways. In the *full information* condition, all participants had information on all transaction amounts (and hence could infer the value of the multiplier) at the end of each round. Participants in this condition called out their transaction values in the presence of the experimenter, the multiplier value, and their total earnings at the end of each round. In the *partial information* condition, participants were only informed about each other's earnings at the end of each round; no information about individual transactions or the multiplier was made available by the participants. In the *no information* condition, participants were not given any information about other players.

Regardless of the treatment, participants were not permitted to speak to each other during the course of the experiment.<sup>8</sup> The experiments were conducted over the course of six months between April and November, 2014 at the Department of Economics Lab at the University of Mumbai. The TBG was programmed and administered using z-Tree (Fischbacher 2007). In each session, a single group of three participants sat at different computer terminals during the experiment, which was administered to each group individually.<sup>9</sup> Written instructions for the TBG were provided to each participant, with a numerical example; the number of rounds in the game was not disclosed to participants.<sup>10</sup> The experiment began with two practice rounds. At the end of the practice, participants' doubts were clarified.<sup>11</sup> Then, five rounds of the TBG were completed within the same group without any change in roles. Participants were paid a Rs. 40 show-up fee, and .50 of their total earnings in the game.

Participants were randomly assigned to either condition, and were randomly assigned to the positions of Player A, B, or C. The average age of participants across conditions was 22.15 years ( $SD = 1.86$ ). 44.16 percent of participants were female. The corresponding characteristics for each group were 27 women,  $M_{age} = 22.59$  years,  $SD = 2.30$  for *no information*; 12 women,  $M_{age} = 22.10$  years,  $SD = 1.99$  for *partial information*; and 14 women,  $M_{age} = 21.77$  years,  $SD = 1.30$  for *full information*. Data from four groups were discarded due to poor comprehension of instructions, and data from two groups was

---

<sup>8</sup> Appendix A contains a copy of the experimental instructions.

<sup>9</sup> Between-subjects anonymity may have been compromised. However, it was ensured that the three participants were not familiar with each other before the experiment, and were asked not to disclose any part of the protocol once they had completed the experiment.

<sup>10</sup> There has been some evidence to suggest that a random termination rule influences trusting behaviour in the trust game (Engle-Warnick and Slonim 2004; Engle-Warnick and Slonim 2006). Literature suggested that both players continued to play equilibrium strategies, similar to results from other experimental games like the prisoner's dilemma (Bó and Fréchette 2011). However, Normann and Wallace (2012) found that termination rules did not influence overall rates of cooperation, even though there may be end-game effects depending on the expected length of a game.

<sup>11</sup> Subjects were not paid for the practice rounds, since they were only implemented to test for participant comprehension of instructions. Given that Indian participants were inexperienced in taking part in experiments, these were necessary. Participants were not regrouped after the practice rounds.

discarded due to technical difficulties. For our analyses, we use  $N = 120$  participants, with 40 groups taking part (20 in *no information* and 10 each in *full and partial information*).

We used the Shapiro-Wilk's test for normality and found that the outcome variables of interest do not follow normal distribution. Thus, instead of independent groups t-tests, we use Mann-Whitney U tests and report medians by treatment and control group to explore the impact of the manipulation of the information condition. The variables of interest were the mean amount of transfers for each dyad (AB-BC-CB-BA), the amount transferred by C over the principal (reciprocity), the amount retained by C over the principal (selfishness), and the average earnings for the players at the end of each round. Additionally, proportions of these transfers were also computed; proportions were better indicators of transfer decisions in this iterated game being relative indices of transfer, as compared to absolute ones. Table 1 displays these results.<sup>12</sup>

### **Table 1 here**

We first checked for differences between partial and full information, finding no statistically significant differences between the two conditions, except for slightly higher levels of reciprocity by the trust broker under full information. This implied that the level of information available did not significantly influence behaviour in the multi-level trust game under uncertain conditions. For all further analyses, we therefore analyse differences between *no information* and *any information* (either *partial* or *full*), and any difference between conditions is taken to indicate a difference between *any information* and *no information*. In line with past literature on information-sharing in the trust game (e.g., Charness, Du, & Yang

---

<sup>12</sup> All variable definitions can be found in Appendix B.

2011), there were statistically significant differences for all transfers between players, with each transfer being higher if information was available. Similar significant results were found for proportion of amount transferred, with the highest difference for B's trustworthiness. Player A gained the most from such information availability, through sending signals of being trusting and trustworthy. Thus, C showed a greater tendency to be trustworthy when information about transfers was available to all other players, signaling his trustworthiness to other players. The largest absolute differences were in the amount transferred from Players C to B (4.46) and B to A (4.47), an indicator of C's greater trustworthiness to B and subsequently B's greater trustworthiness to A, when information about transfers or earnings in each round was made available. This was potentially due to the broker being aware of reputational benefits from building trust, and signaling to B that he is trustworthy. This also shows that when transfer information is made transparent, the levels of transfers are higher under conditions of uncertain returns. However, higher levels of transfers are not necessarily indicative of higher trust or trustworthiness, and hence we need to account for player endowments.

With respect to proportion of transfer, the differences were significant between conditions in the case of each players' trust and trustworthiness. Player A transferred 4% more when information was available; players in the role of B transferred 10% of their available endowment to player C; and in each dyad, trust was reciprocated by each player. C had 9% higher proportion of transfers when information was available and B's trustworthiness behavior was also higher (Player B returned 12% more when transfers or earnings were observable). Notably, only player A's earnings were higher when information was made available, indicating that the (open) initiation of trust by A comes with high returns. In contrast, C comes off with the lowest earnings given that (unlike players A and B), he had no initial endowment to trust with. When information on transfers or earnings was

made available at the end of each round, C retained 70%, compared to only 67% in the case of no information; and C gave only 30% above the required minimum principal under *information*, compared to 33% in the case of *no information*. Given that these differences are not statistically significant, C's selfishness and reciprocity is not significantly influenced by the availability of information.<sup>13</sup>

### Table 2 here

Table 2 shows correlations that explore whether Player C's decision to be reciprocal or selfish was associated with the varying information conditions, other players' transfers, and the random multiplier.<sup>14</sup>

First, when *any* information was available, C's reciprocity was positively correlated with transfers between the three players, except the initial transfer. In fact, C retained more when the initial transfer (AB) was high and (intuitively) less when he reciprocated trust to B. When no information was disclosed, C's reciprocity was associated with his proportion of transfer to B positively, and was statistically significant. In comparison with the case where information was available, we find lower correlations between proportions transferred between the three players. An exception to this was in the transfer from B to A, which is significantly correlated with the initial transfers (AB and BC) in both conditions. Intuitively, this was in line with the assumption that hidden information created incentives for greater selfish behavior, reducing transfers among all players. The exception to this is the final transfer of each round, where player B has the opportunity to reciprocate player A's trust in her – in both groups, we find that B's transfer to A is positively related to A's initial transfer to B as well as B's transfer to C. This implies that a higher (initial) amount of trust is likely to

---

<sup>13</sup> This is not entirely counterintuitive, since Lunawat (2013) found lower investment in a variation of the trust game under conditions of voluntary disclosure of information.

<sup>14</sup> To test whether the value of the multiplier varied randomly between the information conditions and the studies, we conducted a test of differences. No significant differences were found across studies, or across information conditions.

be associated with higher transfers throughout the game. In terms of C's selfishness, we find a higher (positive) correlation with proportion of initial transfer (A's trust in B) when information is available. This is in contrast to C retaining more of his available amount being associated with B's trust in C when no information on earnings or transfers was disclosed. We therefore infer that information has a strong role to play in determining behaviour of trustees and trustors, particularly under conditions of uncertain returns and a third player.

The influence of information availability on decisions was also seen in the context of the multiplier. Of interest are the lower correlations between proportions and the multiplier in the case of *no information* and higher (and in some cases even statistically significant) correlations when information was available. While correlations between proportion of transfers and the multiplier in the *no information* condition were not statistically significant (and close to zero), we find negative correlations between the multiplier and the initial transfers (AB and BC) when information on the multiplier was available. Thus, under uncertain conditions, information availability is strongly associated with transfer decisions between players B and C in the context of a random multiplier. The correlations between C's selfishness and the multiplier suggested that at higher values of the multiplier, C retained more of his available endowment while choosing the amount to transfer to B. The correlation was stronger when transfer amounts or earnings were observable,  $r = .562$ . These suggest that disclosure of information on transfers/earnings was associated with higher selfishness for player C, rather than reciprocity. It is also possible that this was on account of knowledge of a higher multiplier, a finding we explore later in this section. This was counterintuitive since information availability serves as a deterrent for selfishness and an incentive to be socially desirable.<sup>15</sup>

---

<sup>15</sup> Baran et al. (2010) however, found that social desirability is not associated with reciprocity in the trust game. In comparing the strong correlation of alumni donations to business schools, they argued for stronger (unbiased) reciprocal behaviour in a laboratory setting relative to field data.



Given the clear implications of information availability for behaviour of the third player, we test for causal effects in the presence of a random multiplier using a simple linear regression approach as outlined below. Measures of selfishness and reciprocity were regressed on previous transfers (A to B and B to C), the dividend, as well as a binary categorical variable of information disclosure (0 = no information, 1 = information). To allow for a non-linear effect of the information condition, an interaction term was used along with the dividend produced. We also report a separate model accounting for round fixed-effects (to control for learning effects). The results are presented in Table 3.

**Table 3 here**

The results (when round fixed-effects are accounted for) show that a higher multiplied value under *no information* increased the amount retained by C over the available endowment by 0.55, less than reciprocity (0.45). This disparity was much larger when information about transfers or earnings was made public but in the opposite direction: a higher multiplied value under no information increased selfishness by 0.31, but had a large positive effect on reciprocity (0.68). This implied that greater information availability, on average, had a stronger influence on C's decision to be reciprocal, relative to the strategy to retain more of his available endowment. This is in strong contrast to the correlation coefficients discussed earlier, where C's selfishness was more positively associated with the multiplier in the information group, relative to the control group. Although a higher transfer from A to B had no statistically significant effect on C's trust and trustworthiness, a higher B-C transfer sharply reduced C's reciprocity ( $B = -0.70$ ) more than his selfishness ( $-0.29$ ). Thus, when B made a higher transfer to C, he reduces the reciprocal transfer to B by 0.7 but also reduces the amount retained by nearly 0.3. For player B, trusting C therefore almost always results in a lower return on investment, as was indicated by correlations reported under *no information* in Table 2 ( $r = .582$ ). In line with Güth et al. (2014), we find low incidence reciprocity (less

than a unit change) in the case of uncertain returns. Although reciprocity levels are improved under information availability, they continue to remain low.

Despite not being aware of the exact number of rounds, players had incentives to signal their 'type' as trusting or trustworthy due to repeated play and information availability. Round fixed-effects show that relative to the base period (round 1), C was most likely to be reciprocal of trust only in the last round. This is surprising given that no player had knowledge beforehand of the number of rounds that they would be required to play.

### **Figure 2 here**

Figure 2 displays trust and trustworthiness behavior between information conditions and across values of the multiplier. We first note that there was no transfer from player C to B over and above what was invested in C when the multiplier was 1. A multiplier value of 1 is taken to represent no additional returns from trusting behavior, and therefore might indicate the lack of transfers here. Note that while C's selfishness increased with multiplier values when no information was available about transfer or earnings, it reduces (with a concomitant increase in reciprocity) with a higher multiplier value when information was made available. This shows that under conditions of information disclosure in uncertain environments, a higher multiplier is likely to be associated with a higher level of reciprocity, rather than selfishness.

### **Discussion and Conclusion**

The primary motivation of this paper was to extend the existing paradigm of trust, trustworthiness, and reciprocity by introducing a variable multiplier, a third player, and information asymmetry in the context of a repeated trust game setup. We sought to examine

reciprocal and selfish behaviours among players within the proposed TBG by manipulating the amount of information available to players.

There were significant differences in trust and trustworthiness under such uncertain conditions (of a probabilistic multiplier), which also varied by information availability. This indicates that players' beliefs about reputation play a vital role in choosing the level of transfers, and ultimately the initiation and reciprocation of trust in the given framework. For example, where information on earnings or transfers was available, all transfers between players were higher, indicating the positive influence of information availability. This was evident even in the proportion of available (or initial) endowment transferred, which showed greater individual trust and trustworthiness for each player under information availability. Correlations suggested that the trust broker's selfishness was positively associated with the transfer he receives from player B, but when all transfer information is disclosed, this association is no longer statistically significant or positive. Although we do not have a deterministic multiplier group to compare the results of having a random multiplier, correlations suggest that a higher multiplier was associated with more selfishness for the trust broker, regardless of whether information is available. Knowledge of the value of the random multiplier thus, had varied consequences for trust, trustworthiness, and reciprocal behaviours in the game. This was in line with Güth et al. (2014), who suggested that players altered their behaviour when choices were probabilistic rather than deterministic.

We probed further into these associations using linear regressions that interact the multiplied values with information availability. These results show that the initial trusting decision (transfer from A to B) did not determine the trust broker's decisions. Even when learning effects (over rounds) are controlled for, we find strong evidence that information availability leads to a statistically significant increase in the trust broker's reciprocity. In contrast, when no players have no information about transfers and earnings of other players,

the trust broker is more likely to be selfish than reciprocating the trust from player B. We interpret these results as implications of incentivizing players to think about their (and other players') reputations. Similar to the theory in Lunawat (2013), heterogeneous prior beliefs about the 'type' of trustor or trustee drove such behaviour.

Overall, summary statistics suggest that Player A was more likely to maximize earnings when all other transfers were high when information was available. This was similar to the 'transparency effects' found in Rietz et al. (2013); welfare gains (as determined by player earnings) accrued significantly to Player A, and less so to the other players. More evidence of signalling trustworthiness was observed through correlations between B's and C's trustworthiness.

Under a repeated game setting with information asymmetry and uncertainty in the multiplier, players chose to be more trusting and trustworthy since they had the opportunity to build a reputation to be a trustworthy and gain higher earnings during the course of the game. In transfers where all amounts were doubled and such information was known, the trust broker retained a greater proportion of his available endowment, relative to the case where other players did not know the multiplier value. However, when transfers where the multiplier was three, information availability deterred the trust broker from retaining more, while raising the levels of trust among all players.

We highlight the limitations of current work, so that future research in this area can narrow the gap on understanding of trust and trustworthiness in a multi-player framework. First, both samples consisted of novice student participants with administrative constraints preventing efficient implementation of the double-blind procedure, which compromised the execution of the experiment; future work with diverse samples will ensure greater generalizability and external validity of results. Second, since the game required engaging in trusting and trustworthy behaviour in an experimental setting, participants' desire to portray

themselves in a favourable light may have confounded the results. We acknowledge that this may have been particularly an issue in the full information treatment, where participants were required to call out their values. Social desirability effects may have also precluded the display of selfish behaviour; hence, experimenters replicating the paradigm can measure and control social desirability in the future. Likewise, personality correlates of selfishness, Machiavellianism, and subclinical psychopathy may be useful metrics to pre-screen participants to manipulate their role allocation (A, B, or C) in the trust game framework (Eamonn et al. 2011). Altering the source of the money in the game (earnings versus endowments), and revealing ambiguous market conditions through verbal statements (“The market has recorded an all-time high”) are other adaptations of the TBG worthy of investigation.

To conclude, our extension permits the exploration of trust and trustworthiness in a multi-level, uncertain environment, and information asymmetric trust game. We attempted to introduce realistic ambiguity in the vein of financial markets via a random multiplier and random termination rule. The third player allowed for the bifurcation between reciprocal and selfish behaviour when the first-mover and the second-mover can produce trust. The presence of information asymmetries and repeated play allowed us to probe how reputation concerns interacted with transparency (or lack thereof). Thus, the TBG meets its goals of examining multiple transactions, in uncertain market conditions, under varying levels of information.

## References

- Anderhub, Vital, Dirk Engelmann, and Werner Güth. 2002. “An Experimental Study of the Repeated Trust Game with Incomplete Information.” *Journal of Economic Behavior & Organization* 48: 197–216. doi:10.1016/S0167-2681(01)00216-5.
- Baran, Nicole M, Paola Sapienza, and Luigi Zingales. 2010. “Can We Infer Social Preferences from the Lab? Evidence from the Trust Game.” 15654. NBER Working Papers. <http://www.nber.org/papers/w15654>.

- Bauernschuster, Stefan, Oliver Falck, and Niels Große. 2013. "When Trustors Compete for the Favour of a Trustee - A Laboratory Experiment." *Journal of Economic Psychology* 34: 133–47. doi:10.1016/j.joep.2012.09.004.
- Berg, Joyce, John; Dickhaut, and Kevin McCabe. 1995. "Trust, Reciprocity, and Social History." *Games and Economic Behavior* 10 (1): 122–42. doi:0.1006/game.1995.1027.
- Bigoni, Maria, Stefania Bortolotti, Marco Casari, and Diego Gambetta. 2013. "It Takes Two to Cheat: An Experiment on Derived Trust." *European Economic Review* 64: 129–46. doi:10.1016/j.euroecorev.2013.08.009.
- Bó, Pedro Dal, and Guillaume R. Fréchette. 2011. "The Evolution of Cooperation in Infinitely Repeated Games: Experimental Evidence." *American Economic Review* 101: 411–29. doi:10.1257/aer.101.1.411.
- Brühlhart, Marius, and Jean-Claude Usunier. 2012. "Does the Trust Game Measure Trust?" *Economics Letters* 115 (1): 20–23. doi:10.1016/j.econlet.2011.11.039.
- Charness, Gary, Ninghua Du, and Chun Lei Yang. 2011. "Trust and Trustworthiness Reputations in an Investment Game." *Games and Economic Behavior* 72: 361–75. doi:10.1016/j.geb.2010.09.002.
- Eamonn, Ferguson, James J., Heckman, and Philip. Corr. 2011. "Personality and Economics: Overview and Proposed Framework." *Personality and Individual Differences* 51 (3): 201–9.
- Engle-Warnick, J., and Robert L. Slonim. 2004. "The Evolution of Strategies in a Repeated Trust Game." *Journal of Economic Behavior & Organization* 55 (4): 553–73. doi:10.1016/j.jebo.2003.11.008.
- . 2006. "Inferring Repeated-Game Strategies from Actions: Evidence from Trust Game Experiments." *Economic Theory* 28 (3): 603–32. doi:10.1007/s00199-005-0633-6.
- Fischbacher, Urs. 2007. "Z-Tree: Zurich Toolbox for Ready-Made Economic Experiments." *Experimental Economics* 10: 171–78. doi:10.1007/s10683-006-9159-4.
- Güth, Werner, Harriet Muegera, Andrew Musau, and Matteo Ploner. 2014. "Deterministic

- versus Probabilistic Consequences of Trust and Trustworthiness: An Experimental Investigation.” *Journal of Economic Psychology* 42: 28–40.  
doi:10.1016/j.joep.2013.11.003.
- Johnson, Noel D., and Alexandra A. Mislin. 2011. “Trust Games: A Meta-Analysis.” *Journal of Economic Psychology* 32 (5). Elsevier B.V.: 865–89. doi:10.1016/j.joep.2011.05.007.
- Jones, Daniel. N. 2013. “What’s Mine Is Mine and What’s Yours Is Mine: The Dark Triad and Gambling with Your Neighbor’s Money.” *Journal of Research in Personality* 47 (5): 563–71. doi:10.1016/j.jrp.2013.04.005.
- Kiyonari, T., T. Yamagishi, K. S. Cook, and C. Cheshire. 2006. “Does Trust Beget Trustworthiness? Trust and Trustworthiness in Two Games and Two Cultures: A Research Note.” *Social Psychology Quarterly* 69 (3): 270–83.  
doi:10.1177/019027250606900304.
- Kvaløy, Ola, and Miguel Luzuriaga. 2014. “Playing the Trust Game with Other People’s Money.” *Experimental Economics* 17 (4): 615–30. doi:10.1007/s10683-013-9386-4.
- Lunawat, Radhika. 2013. “An Experimental Investigation of Reputation Effects of Disclosure in an Investment/trust Game.” *Journal of Economic Behavior and Organization* 94: 130–44. doi:10.1016/j.jebo.2013.07.018.
- McCabe, Kevin A., Mary L. Rigdon, and Vernon L. Smith. 2003. “Positive Reciprocity and Intentions in Trust Games.” *Journal of Economic Behavior and Organization* 52: 267–75. doi:10.1016/S0167-2681(03)00003-9.
- Normann, HT, and B Wallace. 2012. “The Impact of the Termination Rule on Cooperation in a Prisoner’s Dilemma Experiment.” *International Journal of Game Theory* 41 (3): 707–18. doi:10.1007/s00182-012-0341-y.
- Rietz, Thomas A., Roman M. Sheremeta, Timothy W. Shields, and Vernon L. Smith. 2013. “Transparency, Efficiency and the Distribution of Economic Welfare in Pass-through Investment Trust Games.” *Journal of Economic Behavior and Organization* 94: 257–67. doi:10.1016/j.jebo.2012.09.019.
- Sheremeta, Roman M., and Jingjing Zhang. 2013. “Three-Player Trust Game with Insider

Communication.” *Economic Inquiry* 52 (2): 576–91. doi:10.1111/ecin.12018.

Vranceanu, Radu, Angela Sutan, and Delphine Dubart. 2012. “Trust and Financial Trades: Lessons from an Investment Game Where Reciprocators Can Hide behind Probabilities.” *Journal of Socio-Economics* 41: 72–78. doi:10.1016/j.socec.2011.10.011.



Table 1

*Descriptive Statistics for Average and Proportionate Transactions between Players A, B, and C (information treatments)*

VARIABLES	No Information (Median)	Information (Median)	Mann-Whitney U test	Robust Rank Order Test
Average transfer A to B	2	4	-3.102***	-3.154***
Average transfer B to C	2	4	-3.010***	-3.068***
Average transfer C to B	3	4.500	-3.192***	-3.256***
Average transfer B to A	2	3	-4.351***	-4.647***
Amount C gives over the principal	0	1	-3.348***	-3.119***
Amount C retains over the principal	1	2	-0.958	-0.921
Earnings of Player A	9	10	-3.901***	-4.137***
Earnings of Player B	13	13	0.147	0.145
Earnings of Player C	6	6	0.107	0.106
Proportion transferred from A to B	0.268	0.333	1.515	-1.514
Proportion transferred from B to C	0.160	0.214	-2.891***	-2.986***
Proportion transferred from C to B	0.333	0.429	-2.431**	-2.458**
Proportion transferred from B to A	0.111	0.200	-3.741***	-3.971***
Proportion retained by C	0.854	0.775	0.211	0.199
Proportion given by C	0.146	0.225	-0.211	-0.199

*Note.* \*\*\*  $p < .01$ ; \*\*  $p < .05$ ; \*  $p < 0.1$ .

Table 2

*Correlations between Amounts Earned and Proportions Transacted between Players A, B, and C (Information and No Information groups)*

No Information							
	1	2	3	4	5	6	7
1. Proportion (AB)	1	-	-	-	-	-	-
2. Proportion (BC)	.006	1	-	-	-	-	-
3. Proportion (CB)	.076	.079	1	-	-	-	-
4. Proportion (BA)	.209**	.542***	.002	1	-	-	-
5. Reciprocity	.129	.130	.246**	-.110	1	-	-
6. Selfishness	-.044	.582***	-.135	.184*	-.188*	1	-
7. Multiplier	-0.002	0.072	-0.095	-0.075	0.27***	0.426***	1
Information							
	1	2	3	4	5	6	7
1. Proportion (AB)	1	-	-	-	-	-	-
2. Proportion (BC)	.189*	1	-	-	-	-	-
3. Proportion (CB)	.136	.456***	1	-	-	-	-
4. Proportion (BA)	.299***	.873***	.362***	1	-	-	-
5. Reciprocity	.152	.467***	.395***	.434***	1	-	-
6. Selfishness	.301***	-.019	-.238**	-.010	-.086	1	-
7. Multiplier	0.067	-0.207**	-0.295***	-0.134	0.166*	0.562***	1

*Note.* \*\*\*  $p < .01$ ; \*\*  $p < .05$ ; \*  $p < 0.1$ .

Table 3

*Simple Regression Analyses of Reciprocity and Selfishness as Dependent Variables*

VARIABLES	(1)	(2)	(3)	(4)
	Selfishness	Reciprocity	Selfishness	Reciprocity
No Information * Dividend	0.565*** (0.0897)	0.435*** (0.0897)	0.550*** (0.0927)	0.450*** (0.0927)
Information * Dividend	0.328*** (0.109)	0.672*** (0.109)	0.317*** (0.109)	0.683*** (0.109)
Transfer Amount from Player A to B	-0.152 (0.124)	0.152 (0.124)	-0.159 (0.125)	0.159 (0.125)
Transfer Amount from Player B to C	-0.317** (0.142)	-0.683*** (0.142)	-0.295** (0.143)	-0.705*** (0.143)
<i>Round fixed-effects</i>				
Round 2			-0.973 (0.693)	0.973 (0.693)
Round 3			-1.256 (0.943)	1.256 (0.943)
Round 4			-0.839 (0.637)	0.839 (0.637)
Round 5			-1.516** (0.766)	1.516** (0.766)
Constant	0.717** (0.360)	-0.717** (0.360)	1.672** (0.696)	-1.672** (0.696)
Observations	200	200	200	200
R-squared	0.484	0.637	0.496	0.645

Note. \*\*\*  $p < .01$ ; \*\*  $p < .05$ ; \*  $p < 0.1$ . Robust standard errors reported in parentheses.

*Selfishness* refers to the amount retained by player C over the minimum amount that was transferred to him by player B. *Reciprocity* refers to the amount returned to B by C over the minimum amount. *Dividend* refers to a continuous variable representing the multiplied value of the transfer, where the multiplier varies from 1 to 3. *Information* takes a value of 1 if there was information available on the transfers, the multiplier, and the earnings of all players, and zero if there was no such information available to all players. Round fixed-effects are dummy variables that take the value of one for transfers in that particular round, and zero otherwise.

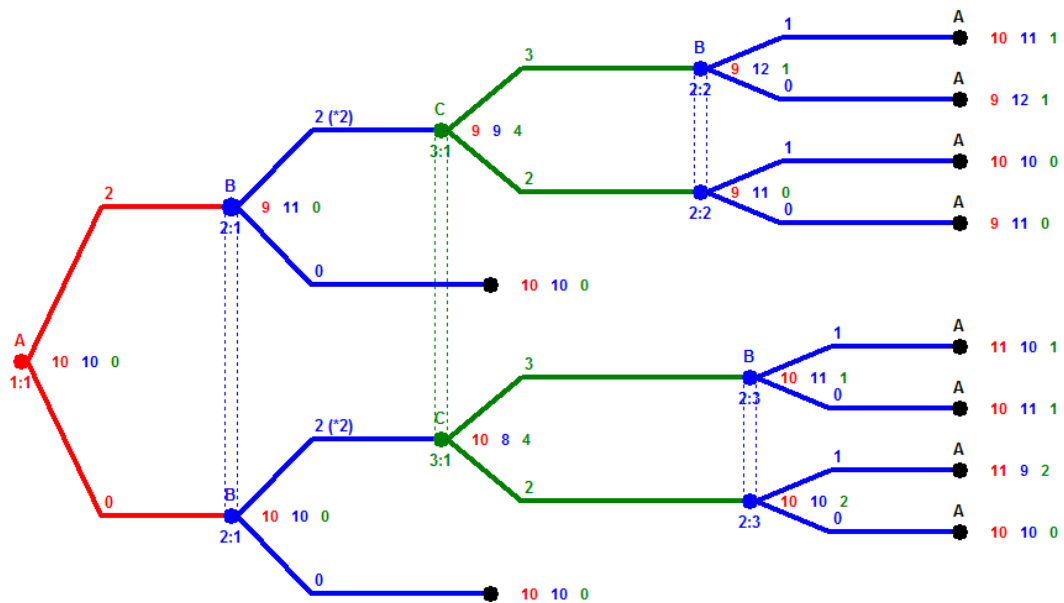

*Figure 1.* One-shot trust broker game with fixed endowments, illustrative case where A transfers 2 to B, and the random multiplier takes the value of 2; C transfers a unit more than the minimum required transfer in this illustration back to B; B transfers either 1 or 0 back to A.

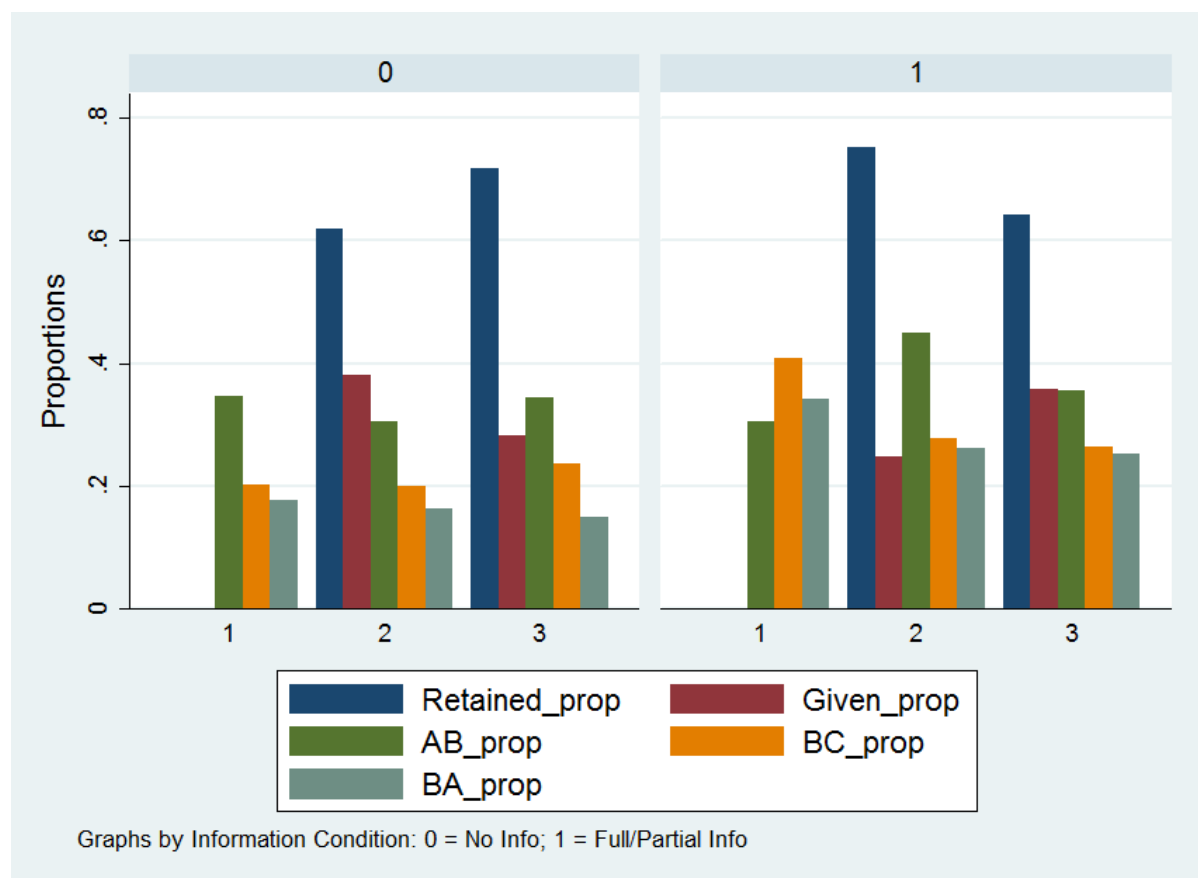

Figure 2: Comparison of Trust and Trustworthiness by Multiplier values and information conditions

*Note:* Retained\_prop refers to Proportion retained by player C over available endowment; Given\_prop refers to Proportion given by player C (to B) over available endowment; AB\_prop refers to proportion of transfer by player A (to B) over available endowment; BC\_prop refers to proportion of transfer by player B (to C) over available endowment; BA\_prop refers to proportion of transfer by player B (to A) over available endowment. No values of Retained\_prop and Given\_prop were recorded when multiplier was 1 since C did not transfer over and above what was invested in him and could not retain any value since the minimum amount required to be returned was the investment.

## Appendix A: Instructions

This is an experiment attempting to study multi-player decision making, to understand group dynamics. The instructions are simple. Please read them carefully.

- This experiment consists of three players 1, 2 and 3 with several rounds.
- Participants will be randomly assigned into various roles as 1, 2 or 3. You will continue to play the assigned player role throughout the experiment.
- During each round, you and the other two participants in your group will make choices which will determine your payoffs.
- The game begins with both player 1 and player 2 having 10 units each. Player 3 has 0 units.
- We assume that players aim at maximizing their gain.

Any questions?      Yes – Ask the experimenter.      No – Read on.

- Each round is comprised of the following stages:
  - At Stage 1, Player 1 can send to Player 2 any amount  $X$ , between 0 and 10 units. This amount gets added to the 10 units in the Player 2's account.
  - At Stage 2, Player 2 then can decide to send any amount between 0 and  $10 + X$  units, he/she wishes, to Player 3.
  - Then, Player 3 receives these  $X$  units which get randomly multiplied by any number ranging from 1 to 4 (i.e., 1, 2, 3 and 4 only).
  - At Stage 3, Player 3 decides the amount he/she wishes to give to Player 2. However, he/she has to return at least the amount received from Player 2.
  - At Stage 4, Player 2 then decides the amount he/she wishes to give to Player 1, if any.
- This was completion of a single round in the game.
- At the beginning of each round, your total earnings made at previous round will be displayed on the screen.
- The same procedure is followed in successive rounds.
- The points earned in one round are carried forward to the next round.

If you have any questions, or need assistance of any kind, please ask the experimenter.

We expect and appreciate your cooperation. We ensure you that the results of this experiment will not be disclosed to anyone and are strictly for the purposes of research.

Following is the numerical illustration of how a single round of this game is played:

Player 1 = 10

Player 2 = 10

Player 3 = 0

Stage 1: Player 1 decides to give 3 units to Player 2; Player 1 now has 7 units ( $10 - 3 = 7$ ).

Stage 2: Player 2 has  $10 + 3 = 13$  now and decides to give 5 units to Player 3; Player 2 now has  $13 - 5 = 8$  units.

Now, Player 3 has got 5 units from Player 2. This is randomly multiplied by a number from 1 to 4; in this case it is 3. So Player 3 now has  $5 \times 3 = 15$  units.

Stage 3: Player 3 has to give Player 2 at least the PRINCIPAL AMOUNT, here 5 units. But Player 3 decides to give back 8 units. Now Player 3 has  $15 - 8 = 7$  units.

Stage 4: Player 2 had 8 units, and now got 7 units from Player 3. Player 2 now has 15 units in total. Player 2 has to decide how much to give to Player 1. Player 2 gives Player 1 4 units.

At end of Round one:

Player 1 now has  $7 + 4 = 11$

Player 2 now has  $15 - 4 = 11$

Player 3 now has  $15 - 8 = 7$

In this game, there will be two practice periods at the start, before the main game begins.

The amount earned in the practice periods will not be carried forward to the main game.

Any questions?      Yes – Ask the experimenter.      No – Let's begin.

### **Partial Information Condition**

Participants were asked to call out their final earnings in each round after the completion of Stage 4 only in each round.

### **Full Information Condition**

Participants were asked to call out each transaction value, including the multiplier value for the third player, after the completion of each stage in each round.

## Appendix B: Variable Definitions

Variable	Definition
Average transfer A to B	The amount of money transferred from the first player to the second player over all rounds, both of whom have initial endowments of Rs. 10
Average transfer B to C	The amount of money transferred from the second player to the third player (the trust-broker) over all rounds, where only the second player has an initial endowment of Rs. 10
Average transfer C to B	The amount of money transferred from the third player to the second player over all rounds
Average transfer B to A	The amount of money transferred from the second player to the first player over all rounds; this is the last transfer in an iteration of the game
Amount C gives over the principal ( $M_b^c - M_c^b$ )	The amount returned to the second player by the third player, less the amount that he received from the second player. This cannot be less than zero (Reciprocity)
Amount C retains over the principal	The amount retained by the third player, over the amount that he received from the second player (Selfishness)
Earnings of Player A ( $P_a^4$ )	The cumulative payoff for the first player at the end of an iteration of the game.
Earnings of Player B ( $P_b^4$ )	The cumulative payoff for the second player at the end of an iteration of the game.
Earnings of Player C ( $P_c^4$ )	The payoff for the third player at the end of an iteration of the game.
Proportion transferred from A to B ( $M_b^a/M_a$ )	The fraction of amount transferred out of the endowment at the start of the $i^{\text{th}}$ round from the first player to the second player.
Proportion transferred from B to C ( $M_c^b/M_b$ )	The fraction of amount transferred out of the endowment at the second stage of the $i^{\text{th}}$ round from the second player to the third player.
Proportion transferred from C to B ( $M_b^c/k \cdot M_c^b$ )	The fraction of amount transferred out of the endowment at the third stage of the $i^{\text{th}}$ round from the third player to the second player.
Proportion transferred from B to A ( $M_a^b/P_b^3$ )	The fraction of amount transferred out of the endowment at the fourth stage of the $i^{\text{th}}$ round from the second player to the first player
Proportion given by C	Amount C gives over the principal as a fraction of the multiplied amount (Reciprocity)
Proportion retained by C	Amount C Retains over the principal as a fraction of the multiplied amount (Selfishness)



Please note:

You are most sincerely encouraged to participate in the open assessment of this discussion paper. You can do so by either recommending the paper or by posting your comments.

Please go to:

<http://www.economics-ejournal.org/economics/discussionpapers/2017-33>

The Editor