

Pauliuk, Stefan; Neuhoff, Karsten; Owen, Anne; Wood, Richard

Working Paper

Quantifying impacts of consumption based charge for carbon intensive materials on products

DIW Discussion Papers, No. 1570

Provided in Cooperation with:

German Institute for Economic Research (DIW Berlin)

Suggested Citation: Pauliuk, Stefan; Neuhoff, Karsten; Owen, Anne; Wood, Richard (2016) : Quantifying impacts of consumption based charge for carbon intensive materials on products, DIW Discussion Papers, No. 1570, Deutsches Institut für Wirtschaftsforschung (DIW), Berlin

This Version is available at:

<https://hdl.handle.net/10419/137586>

Standard-Nutzungsbedingungen:

Die Dokumente auf EconStor dürfen zu eigenen wissenschaftlichen Zwecken und zum Privatgebrauch gespeichert und kopiert werden.

Sie dürfen die Dokumente nicht für öffentliche oder kommerzielle Zwecke vervielfältigen, öffentlich ausstellen, öffentlich zugänglich machen, vertreiben oder anderweitig nutzen.

Sofern die Verfasser die Dokumente unter Open-Content-Lizenzen (insbesondere CC-Lizenzen) zur Verfügung gestellt haben sollten, gelten abweichend von diesen Nutzungsbedingungen die in der dort genannten Lizenz gewährten Nutzungsrechte.

Terms of use:

Documents in EconStor may be saved and copied for your personal and scholarly purposes.

You are not to copy documents for public or commercial purposes, to exhibit the documents publicly, to make them publicly available on the internet, or to distribute or otherwise use the documents in public.

If the documents have been made available under an Open Content Licence (especially Creative Commons Licences), you may exercise further usage rights as specified in the indicated licence.

1570

Discussion
Papers

Quantifying Impacts of Consumption Based Charge for Carbon Intensive Materials on Products

Stefan Pauliuk, Karsten Neuhoff, Anne Owen and Richard Wood

Opinions expressed in this paper are those of the author(s) and do not necessarily reflect views of the institute.

IMPRESSUM

© DIW Berlin, 2016

DIW Berlin
German Institute for Economic Research
Mohrenstr. 58
10117 Berlin

Tel. +49 (30) 897 89-0
Fax +49 (30) 897 89-200
<http://www.diw.de>

ISSN electronic edition 1619-4535

Papers can be downloaded free of charge from the DIW Berlin website:
<http://www.diw.de/discussionpapers>

Discussion Papers of DIW Berlin are indexed in RePEc and SSRN:
<http://ideas.repec.org/s/diw/diwwpp.html>
<http://www.ssrn.com/link/DIW-Berlin-German-Inst-Econ-Res.html>

Inclusion of consumption of carbon intensive materials in emissions trading - quantifying the impact across commodity groups

Stefan Pauliuk,¹ Karsten Neuhoff,² Anne Owen,³ and Richard Wood⁴

April 21st, 2016

After the Paris Climate Agreement, it is anticipated that carbon prices will differ across regions for some time. If countries use free allowance allocation as carbon leakage protection, only a fraction of carbon prices are passed through to consumers particularly by carbon intensive materials producers. Adding a consumption charge based on benchmarks applied to the material content can reinstate the carbon price signal. The paper investigates the implications of such a consumption charge for industry and consumers based on material flow analysis and material flow cost accounting. The material-related carbon liabilities for production, import, export, and consumption are estimated for 4000 commodity groups that contain one or more of the five bulk materials steel, aluminium, plastics, paper, and cement. Assuming an underlying carbon price of 30 Euros per ton of CO₂, the total charge to European final consumers is estimated to be about 17 billion EUR. The total charges levied on imports and those waived for exports are each of similar size and roughly amount to half of the total charge to European final consumers. To reduce administrative efforts, the charge is not levied on imported products for which the value of the consumption charge compared to product price falls below a threshold. Thus administrative efforts for 77 to 83% of imports could be avoided while still 85% to 90% of import-related carbon liabilities are included.

Keywords: Material flow analysis, Material flow cost accounting, Carbon Pricing, Inclusion of Consumption, EU Emissions Trading System,

JEL classifications: F18 - Trade and Environment, H23 - Externalities; Redistributive Effects; Environmental Taxes and Subsidies, Q56 - Environment and Development; Environment and Trade; Sustainability; Environmental Accounting

1) Faculty for Environment and Natural Resources, University of Freiburg, D-79106 Freiburg, Germany, stefan.pauliuk@indecop.uni-freiburg.de

2) DIW Berlin, D-10117 Berlin, kneuhoff@diw.de

3) School of Earth and Environment, University of Leeds, Leeds. LS2 9JT, United Kingdom, a.owen@leeds.ac.uk

4) Industrial Ecology Programme, Norwegian University of Science and Technology (NTNU), N-7491 Trondheim, Norway, richard.wood@ntnu.no

1. Introduction

In Emission Trading Systems allowances are allocated for free to producers of carbon intensive materials like steel, aluminium, paper, plastics, and cement. This free allocation addresses concerns that additional costs for carbon emissions could result in relocation of production or investment decisions towards regions with lower carbon prices, so called *carbon leakage* (European Commission, 2016). The allocation of the allowances is based on benchmarks so as to preserve incentives for efficiency improvements of primary production. To ensure leakage protection and limit surplus allocation, the allocation is linked to activity level requirements and production volumes. Together with the convergence of prices through international trade this reduces the share of the carbon cost that is passed through to material prices and reduces the economic incentives for more efficient usage of these materials and material substitution. As final consumers do not pay for incremental costs, also the business case for the development of technologies for material production at incremental costs but with lower carbon emissions is reduced.

A consumption-based charge for emissions intensive materials can re-establish price signals for more climate-efficient material use in the manufacturing sectors and for end users (Neuhoff et al., 2016). The administrative burden of its implementation can, if designed in the right way, be moderate and does not provide disincentives for using recycled material or material with lower carbon footprint.

The administration cost is limited by focusing on carbon intensive materials with the biggest emission share. Complexity of tracing and monitoring is further reduced by using only one emissions benchmark for each material, irrespective of the production process. This also ensures compatibility with the rules of consumption charges. The benchmark for each material should thus reflect the carbon intensity of the marginal unit of production to serve final demand. With such a uniform approach, an appropriate incentive is provided encouraging the use of higher value materials, materials substitution, or efficient material use; any one potentially saving the emissions linked to this marginal unit. Incentives for efficient production of materials by installations covered by the ETS continue to be provided by the coverage of installations for material production and their electricity providers. Installations incur costs for emissions above benchmark level and can benefit from outperforming the benchmark.

We provide a quantitative analysis of the economic and administrative implications of adding such a consumption charge to an ETS system (*'Inclusion of consumption', IoC*). Our analysis gives an estimate of the total volume of liabilities created, the significance of imports and exports, and the distribution of liabilities across commodity groups. We motivate our analysis with three research questions, listed below. The analysis focuses on the carbon intensive materials steel, aluminium, plastics, paper, and cement.

First, we investigate how big the liabilities are that are generated in the material production industries and during import, and how big are the liabilities acquitted by final consumers or exporters.

Second, we estimate the size of the liabilities relative to the product prices to get an idea of how large price signals could be and to understand the impacts on product prices. This estimate is the basis for the design of a *de-minimis* rule for product categories on which at the time of import no liability for the consumption charge needs to be created. The objective of the de-minimis rule is a limitation of administrative costs without creating undue advantages along the value chain. We ask what price changes are to be expected if a uniform system-wide carbon liability for materials was implemented and how the price changes are distributed across commodity groups.

Third, to keep the administrative burden low and the scheme effective, we assess how the liabilities are distributed across the commodity groups. This includes identifying which commodity groups are entirely made of steel, aluminium, plastics, paper, or cement: Their associated liabilities can be determined from their weight alone.

2. Methodology

We applied a combination of material flow analysis (MFA) and material flow cost accounting (MFCA) to estimate absolute and relative liabilities (Guenther, Jasch, Schmidt, Wagner, & Huisingh, 2012; Kytzia, Faist, & Baccini, 2004; Pauliuk, Majeau-Bettez, & Müller, 2015; A. Schmidt, Götze, & Sygulla, 2014; M. Schmidt, 2014).

As basis for our estimates we used the Europe-wide statistics on production, import, and export of manufactured goods (ProdCom), which is published by EuroStat annually for 4047 commodity groups in a refined NACEv2 classification (Eurostat, 2013). ProdCom statistics are reported in value units (EUR, layer 1) and volume units (kg for bulk materials, pieces for most manufactured goods, m² for textiles..., layer 2). The geographical scope is the EU28, the reference year we chose is 2012, the most recent year for which complete data were available.

Figure 1 shows the system definition. For each investigated commodity, we determined the apparent consumption with the market balance (equation 1):

$$\text{Consumption} = \text{Production} + \text{Import} - \text{Export} \quad (1)$$

The system in Figure 1 was quantified for the flows of the different commodities for the reference year 2012 and with the EU28 as regional scope. Quantification was done for the monetary, physical, mass, and the five material layers for steel, aluminium, plastics, paper, and cement.

System boundary: EU28, 2012, one global market for each ProdCom group (X)

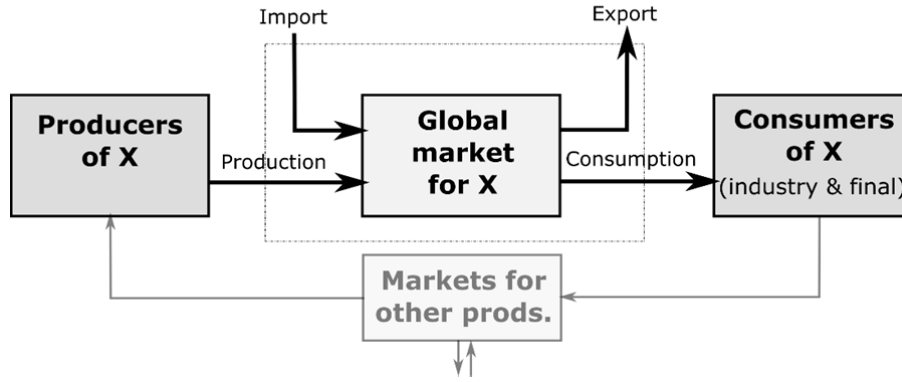

Figure 1. System definition. The drawing shows the global market for a selected commodity X. In total, 4047 such markets were considered.

We briefly describe the calculation scheme applied to the commodity markets and introduce the central parameters for the MFCA, which are explained in detail below. Figure 2 shows the scheme of calculations that was applied to the flows shown in Figure 1.

In a first step, we *filled data gaps* for the physical ProdCom account. Then, we converted all physical units to kg by multiplying the physical units with a conversion factor *kg/unit*. Then, we multiplied the mass flows of the 4047 categories with a group-by-group estimate of the *material content for the six materials* studied. We multiplied the so-obtained flows of embedded materials with the respective *carbon emissions benchmarks* for the six materials, and obtained the carbon charge embedded in the product flows by multiplying the embodied carbon emissions by the *carbon price*.

The five main results of the calculations are shown as grey boxes in Figure 2. We present the equations for each of them:

$$\begin{aligned} \text{Rel. embodied carbon} &= 1 \text{ unit} \times \text{kg/unit} \times \text{Material content} \times \text{Carbon intensity} \\ [kg_{CO_2} / kg] &= 1 \text{ unit} \cdot [kg / \text{unit}] \cdot [kg / kg] \cdot [kg_{CO_2} / kg] \end{aligned} \quad (1)$$

$$\begin{aligned} \text{Embodied carbon} &= \text{Volume} \times \text{kg/unit} \times \text{Material content} \times \text{Carbon intensity} \\ [kg_{CO_2}] &= [\text{unit}] \cdot [kg / \text{unit}] \cdot [kg / kg] \cdot [kg_{CO_2} / kg] \end{aligned} \quad (2)$$

$$\begin{aligned} \text{Rel. embodied liability} &= 1 \text{ unit} \times \text{kg/unit} \times \text{Material content} \times \text{Carbon intensity} \times \text{Carbon price} \\ [€/kg] &= 1 \text{ unit} \cdot [kg / \text{unit}] \cdot [kg / kg] \cdot [kg_{CO_2} / kg] \cdot [€/kg_{CO_2}] \end{aligned} \quad (3)$$

$$\begin{aligned} \text{Embodied liability} &= \text{Volume} \times \text{kg/unit} \times \text{Material content} \times \text{Carbon intensity} \times \text{Carbon price} \\ [€] &= [\text{unit}] \cdot [kg / \text{unit}] \cdot [kg / kg] \cdot [kg_{CO_2} / kg] \cdot [€/kg_{CO_2}] \end{aligned} \quad (4)$$

Finally, by dividing the total embedded liability by the monetary value of the flow, we obtained the ratio of liability to value, or – if the liability is paid – the relative price change

$$\begin{aligned} \text{Rel. price change} &= 100 \times \text{Total liability} / \text{Value} \\ [%] &= 100 \cdot [€] / [€] \end{aligned} \quad (5)$$

For each of the five quantities, a sensitivity analysis was performed, and low, medium, and high estimates were calculated, depending on possible variations in material content. A ranking of the material content by group, the total liabilities by group, and the price changes by group helped us to identify which commodities are the most and the least affected by the emissions inclusion scheme, and our findings inform the discussion on threshold levels and economy-wide impacts. The quantitative results were obtained with a Python script.

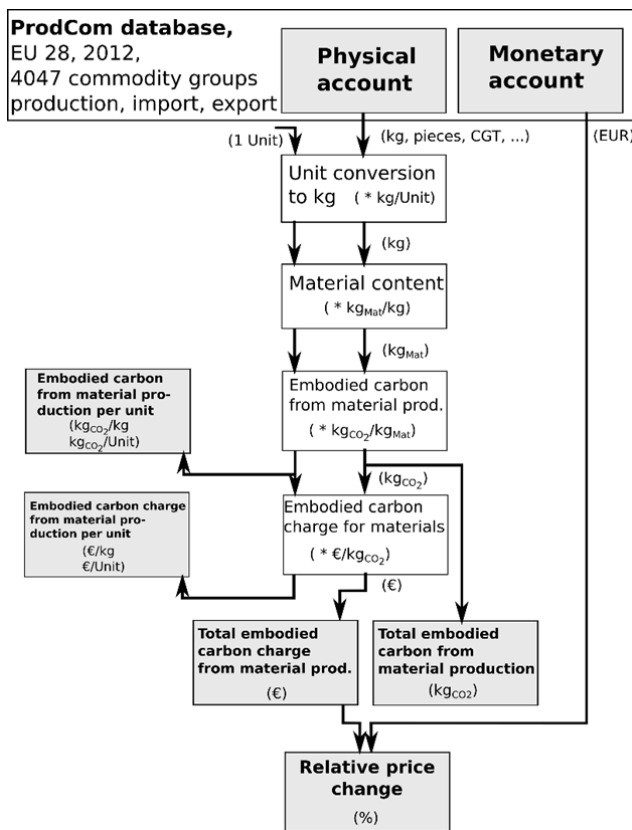

Figure 2: Calculation scheme for the estimation of liabilities and price changes for the 4047 ProdCom commodity groups.

3. Data collection and refinement

To estimate total liabilities we needed physical production and trade volumes at high commodity resolution. These data were obtained from the ProdCom database (Eurostat, 2013). To be compatible with the ProdCom categorization we also estimated the relative liabilities in the same classification. The ProdCom database is neither complete nor fully reliable, and we had to estimate missing physical data and correct the price estimates. Our treatment of the ProdCom raw data is documented here.

Physical and monetary production accounts

Monetary production and trade accounts are usually the ones with the best coverage, and we used these data as our reference. These data were not corrected and no check for completeness was performed. Physical data were often incomplete, however, and we estimated some of the missing data. First, we aggregated both monetary and physical flows to the 4-digit NACEv2 classification, which includes 240 commodity groups at the 4 digit level. For commodity groups with nonzero monetary flows but where no physical production account was present, we used the monetary production figure multiplied with the kg/EUR intensity of the corresponding 4-digit aggregation of the ProdCom database to estimate a proxy production mass flow. For some groups, no export and import-related physical data are present, and we then use the 4-digit aggregation of the trade data to determine a proxy in the same way as described above. In cases where there were no physical trade data in the 4-digit aggregation, we take the 4-digit production account as proxy to estimate the kg/EUR ratio for this aggregated group. With this method a mass flow account could be estimated for about 25% of the 4047 groups. For some groups, however, no physical data were present at all, and these groups (Table 1) were excluded from our analysis.

Table 1. List of 4-digit ProdCom groups where no physical data were available and that were therefore excluded from our analysis.

NACE v2 Code	Name	Potentially relevant for IoC
1330	Dying and printing services	No (Service)
1420	Articles of fur skins	No
1812	Printed newspapers, books, maps, etc.	Yes
1814-1820	Printing and reproduction services	No (Service)
2120	Medicaments and Vaccines	No
2550	Die-forged, drop-forged, and extruded metal parts	Yes
2561	Metallic coating and painting services	No (Service)
2562	Turned metal parts	Yes
2999	Flashlights, image and cinematic projectors etc.	Yes
3212	Goldsmiths' wares, other articles of precious metals	No
3311-3320	Maintenance, repair, and installation services	No (Service)

With the monetary account remaining unrefined due to a lack of reference data, some groups for manufactured products showed unrealistically high relative liabilities for production flows, which were in some cases much higher than the relative liabilities for the pure bulk materials. For example, 'Weirs, sluices, lock-gates, landing stages, fixed docks and other maritime and waterway structures, of iron or steel, Structures and parts of structures of iron or steel, n.e.s.' (26601230) showed a relative liability of about 22%, whereas for finished steel, it is only about 8%. Another example is 'Artificial monofilament of <= 67 decitex [...]' (25112355), for which a relative price change for production of about 18% was reported, whereas for plastics/polymers, it was only about 1.6 %. These reason for these large relative liabilities stems from unrealistically low original average prices per kg in the ProdCom Database and from uncertainties regarding the conversion from the physical units to kg.

The large relative liabilities did not result from all ProdCom accounts, which is a further indication for incomplete or erroneous data. For example, the calculated relative liabilities for the import and export accounts, (not the production account) of 'Artificial monofilament of ≤ 67 decitex [...]' (20602400) was below 0.2%, which is more realistic since the relative liability of plastics is about 1.6% and the degree of fabrication of artificial monofilaments is higher than the one of plastics.

We considered those cases where the calculated relative liabilities are significantly higher than the values for the pure bulk materials as outliers, and assume that in reality, products from these groups would not experience such a large price increase under an implementation of the consumption based charge. Therefore in the Python script we performed the following refinement: For production, import, and export accounts, we checked whether the relative liability was larger than the sum of the relative liabilities of the constituting materials, weighted by their respective material content. If this was the case, we checked whether the group is a pure bulk material. If yes, we replaced the calculated value by the reference value for this bulk material, which are presented below. If not, we took the relative liability of the 4-digit aggregation as proxy.

Conversion of physical units into kg (kg/unit)

The production and trade volumes of most manufactured goods and all vehicles are not reported in kg, as required for the material content estimation, but in other physical units including pieces (for manufactured goods, electronic components, or vehicles), square metres (m^2 , for textiles or glass), or compensated gross tonnage (CGT, for ships). All these units had to be converted into kg in order to determine the material embedded in the mass flows. There are no official or established data sets for the weight per unit for different commodity groups. Although the classification is very detailed, the physical inhomogeneity within a single group can be significant. Consider, for example, the group 'Bodies for lorries, vans, buses, coaches, tractors, dumpers and special purpose motor vehicles including completely equipped and incomplete bodies, vehicles for the transport of ≤ 10 persons' (29201050). It is not possible to say what the exact mass of an item in this group is, not only because it contains the bodies of different types of vehicles (lorries, coaches, tractors), but mainly, because it not only contains completely equipped bodies, but also incomplete bodies. Moreover, the composition of this group will change depending on where and when it is measured. The import of this group to France in 2012 is likely to have a very different composition from the production flow for this group in Sweden in the same year. The kg/unit conversion factors that we compiled and estimated are therefore to be seen as guidance values only that shall give a rough indication of the mass flows produced and traded. This rough estimate is sufficient to give an overview of the magnitude of liabilities embedded in manufactured goods and the relative price changes that are to be expected. It cannot replace, however, the determination of the liability and the price change for a specific good at a specific point in the economy.

Material content for steel, Al, copper, plastics, paper, and cement, group by group

There are no official or established data sets for the material content of different commodity groups. Although the classification is very detailed, the physical inhomogeneity within a single group can be significant. Consider, for example, the group ‘Motor vehicles with a petrol engine > 1500 cm³’ (29102230). Neither is it not possible to say what the exact mass of an item in this group is, nor can we specify the material content with high accuracy. The reason behind the first item is that the engine volume can take any reasonable value larger than 1500 cm³ or the specific technology or degree of equipment of the vehicle is not specified. The reason behind the second item is that there is considerable freedom in the choice of materials. Next to steel, the vehicles could contain considerable amounts of aluminium, carbon fibre or other fibre-reinforced composites (Allwood et al., 2012; Modaresi, Pauliuk, Løvik, & Müller, 2014). We applied a so-called ‘bottom-up’ approach when determining the content of steel, aluminium, copper, plastics, paper, and cement of the 4047 commodity groups, and assessed the uncertainty of our estimates.

Many groups, including agricultural products or minerals, clearly do not contain any of the six materials within the scope. The material content of those groups was set to zero. Others, for example, steel or plastic bulk commodities, have a definite material content of close to 100%. The material content of those groups was set to values between 96% and 100% to take into account the content of possible alloy elements or other additives. For all other groups, including all manufactured products, our estimation of material content group by group relies on expert knowledge and previous experience in tracing steel, aluminium, and cement through the world economy using the SITC1 classification (Liu & Müller, 2013; Müller et al., 2013; Pauliuk, Wang, & Müller, 2013). Moreover, we could use the peer-reviewed published results of the STAF project for estimating the steel and aluminium content of manufactured goods (Graedel et al., 2004; Johnson, Schewel, & Graedel, 2006). The results of the previous studies were matched to the NACEv2 classification and then checked group-by-group and refined where necessary. Uncertainties were estimated and in the dataset. In general, uncertainty is lowest for product groups with very high content of a specific material (down to +/- 5 percentage points), and highest for manufactured products with only minute amounts of materials.

Carbon emissions benchmarks for steel, aluminium, plastics, paper, and cement

To estimate the embodied GHG emissions in the five materials, we constructed process chains for the production of each material, in which the material or its precursors accumulate embodied GHG emissions (Figure A1). To quantify the emissions in the process chain of the products we combined process inventory data from the Ecoinvent life cycle database (Ecoinvent Centre, 2014) with current process-specific EU-ETS benchmarks for direct emissions (European Commission, 2011) and electricity use (European Commission, 2012a, 2012b). The existence or non-existence of EU-ETS benchmarks defined the scope of the process chain. This combination of EU-ETS process benchmarks with a simple product system model gave us product-specific benchmarks for the carbon emissions embodied in the five materials. For each material a specific system for its primary production was drawn and all relevant EU-ETS benchmarks were included (Figure A1). The resulting product-

specific benchmarks are listed and explained below (in tons of CO₂-eq. per ton of material). For all electricity use a benchmark of 0.76 t CO₂ per MWh was used, which is the EU-ETS benchmark of electricity generation in West Central Europe, and which lies roughly in the middle of the spectrum of the carbon intensity of European power production (European Commission, 2012a, 2012b).

- **Steel: 1.78:** The process chain for steel contains the production of coke and iron ore sinter with their respective EU-ETS benchmarks, the blast furnace, which is also included (EU Directive, L130/19), and the basic oxygen furnace with subsequent casting and rolling, for which the EU-ETS specifies a benchmark for electricity use (2012/C 387/06, and EU Communication, C158/22). We assumed that all iron is supplied by pig iron from the blast furnace.
- **Aluminium: 12.82:** The process chain for aluminium production contains the production of refined aluminium oxide and the associated electricity generation, the production of the anodes for the alumina reduction process, and the electrolysis with process emissions (EU Directive, L130/20) and associated electricity generation (2012/C 387/06). Electricity-related emissions for the electrolysis contribute with about 10.8 tons to the total product benchmark.
- **Cement: 0.69:** For grey cement klinker a benchmark for the rotary kiln of 0.766 is given (EU Directive, L130/20). The klinker content of cement varies and the exact benchmark for cement is therefore subject to debate. We assumed a system-wide klinker content of cement of 90% according toecoinvent, which gives a benchmark for cement of 0.69. Electricity-related emissions, for example in the klinker mill, are not included in the EU-ETS.
- **Paper: 0.40:** For paper production we included both the paper and the pulp mill. According to Ecoinvent about one ton of pulp is required per ton of paper. For pulp we took the average of the EU-ETS benchmarks for long and short fibre pulp (0.06 and 0.12) and for paper we took the average of the EU-ETS benchmarks for newsprint and fine paper (0.298 and 0.318, EU Directive, L130/24 + 25).
- **Plastics: 1.5.** Polyvinyl chloride (PVC) is the only plastic for which the EU-ETS covers the polymerization process. A process chain for PVC was constructed using stoichiometric data on the vinyl chloride monomer content of PVC (100%) and the chlorine content of vinyl chloride (57%). Electricity-related emissions for chlorine production as well as direct emissions from the monomer production and the polymerization steps were included as well (EU Directive, L130/28). The product-related benchmark was found to be 1.50, and the main contributor is the chlorine production step with ca. 70%. No analogue calculation for the other major plastics, including polyethylene (PE), polypropylene (PP), and polystyrene (PS) could be performed since the polymerization of these plastics is apparently not directly reflected in EU-ETS benchmarks. A comparison of the cradle-to-gate CO₂ emissions of the four plastics from Ecoinvent data showed that PVC (with 2.3 kg CO₂ per kg PVC) is in the middle of the spectrum of CO₂ intensities (1.5 kg CO₂ per kg PE, 1.7 kg CO₂ per kg PP, and 2.7 kg CO₂ per kg PS). We therefore used the PVC product benchmark as proxy for plastics, acknowledging that

this assumption needs to be refined in the future and that actual plastics-related embodied emissions that are within the scope of the EU-ETS might be lower than the benchmark used in this work.

The resulting product-related benchmarks comprising the relevant production steps are listed in Table 2.

Table 2. Emissions benchmarks used for determining the volume of liabilities incurred and acquitted.

Material	Emissions benchmark for primary production (kg CO ₂ /kg)	Reference	Liability for 100% material content (EUR/ton)
Steel	1.78	EU-ETS, ecoinvent	53
Aluminium	12.82	EU-ETS, ecoinvent	385
Plastics	1.50	EU-ETS, ecoinvent	45
Paper	0.40	EU-ETS, ecoinvent	12
Cement	0.69	EU-ETS, ecoinvent	21
Carbon price (Euro/kg of CO ₂)	0.03	Assumption	

The carbon price was assumed to be at 30 €/ton CO₂, or 3 Cent/kg CO₂, which is a hypothetical but possible price for the next decades, when deep decarbonisation may take place.

With a given carbon benchmark for a material, one can calculate the maximum absolute price change due to the carbon liabilities for materials for a ton of product, which would occur if the product consisted to 100% of the given material (equ. 7).

$$\text{Max. price change / kg} = \text{Carbon footprint / kg} * \text{carbonprice / kg} \quad (6)$$

Results for the maximum absolute price change (or the liabilities for pure materials) are shown in the rightmost column of Table 2. With the given emissions benchmarks and carbon price, they range from 12 Euro/ton for paper to 385 Euro/ton for aluminium.

Commodity prices

To convert the carbon footprints per monetary unit of output into emissions benchmarks per mass (t/t), we divided the monetary benchmarks by the average price of supplying one ton of material. We used average commodity prices for the reference year 2007, which were obtained from a number of price index databases (Table 3). The reference year 2007 was chosen for compatibility reasons, as we also used the multi-regional input output model EXIOBASE for the analysis of the consumption based charge, and these data have 2007 as their reference year.

Table 3. Average commodity prices and references.

Material	Average price, 2007, MEUR/ton	Reference
Steel	0.000475	http://www.indexmundi.com/commodities/?commodity=cold-rolled-steel&months=300&currency=eur
Aluminium	0.001900	http://www.indexmundi.com/commodities/?commodity=aluminum&months=300&currency=eur
Plastics	0.000825	http://www.plastemart.com/lme_prices.asp?pricedate=2/10/2007
Paper	0.000800	Metsä Board's 1Q 2014 interim report presentation
Cement	0.000075	http://minerals.usgs.gov/minerals/pubs/commodity/cement/myb1-2007-cemen.pdf

Total production volumes

Table 4 shows the total production volumes for the six materials studied. These values were used to estimate the total liabilities generated during production.

Table 4. Production volumes of the six materials studied, EU28, 2012, in Mt.

Material	Total production, EU28, 2012, Mt	Reference
Steel	160	WorldSteel: Steel Statistical Yearbook, 2015
Aluminium	3.6	http://www.world-aluminium.org/statistics/
Plastics	57	http://www.plasticseurope.org/documents/document/20150227150049-final_plastics_the_facts_2014_2015_260215.pdf
Paper	100	http://www.cepi.org/system/files/public/documents/publications/statistics/2015/Key%20Statistics%202014%20FINAL.pdf
Cement	170	http://www.cembureau.be/sites/default/files/Cement%20production%20in%20in%20CB%20and%20EU28.pdf

4. Results and discussion

A systems perspective on commodity flows under Inclusion of consumption

A consumption charge is applied to all goods sold to domestic consumers, irrespective of location of production or type of production process. Thus it also applies to imported goods so that final consumers see the same price signal for both imported and domestically produced goods. On the other hand, there should be no charge imposed on exported goods. These requirements lead to a scheme of liability creation and acquitting associated with material-intensive commodity flows (Figure 3). At the point of production, a liability is created for each material that falls under the scheme (case (1) in Figure 3). The liability is also created if the relevant materials are imported (case 6, 7, 8). The material-related liability is calculated as the product of the weight of material produced, the material-specific carbon benchmark, and the current carbon price. Companies can register for duty suspension agreement (DSA). In this case companies can acquire and handle materials with the charge without payments for the liability. They pass the liability along the value chain with the products sold.

Firms within the DSA can choose to pay the liabilities (case 4, 5) or pass it on to registered parties (case 2, 3). Firms will likely chose to directly pay the liability to avoid administrative

efforts if price changes are minute or products are not intended for exports. Hence domestic consumers will bear the consumption charge, irrespective of location or process of the production. This creates incentives for final consumers, but probably more relevant, intermediate consumers – namely manufacturers – to use materials more efficiently or substitute with less carbon intensive options.

To avoid charges on foreign consumers, the liability is acquitted if materials or products are exported (case (6)). However, if domestic firms that chose not to participate in DSA export products, then the liability can no longer be acquitted. To avoid incentives for fraud, financial compensation of previously incurred consumption charges is not envisaged (case (10)).

The central policy design choice that will determine the administrative efforts and incentives that result from the consumption charge is the definition of the de-minimis rule. For which product categories do importers not incur a liability and are consumers of imported products therefore exempt from the consumption charge?

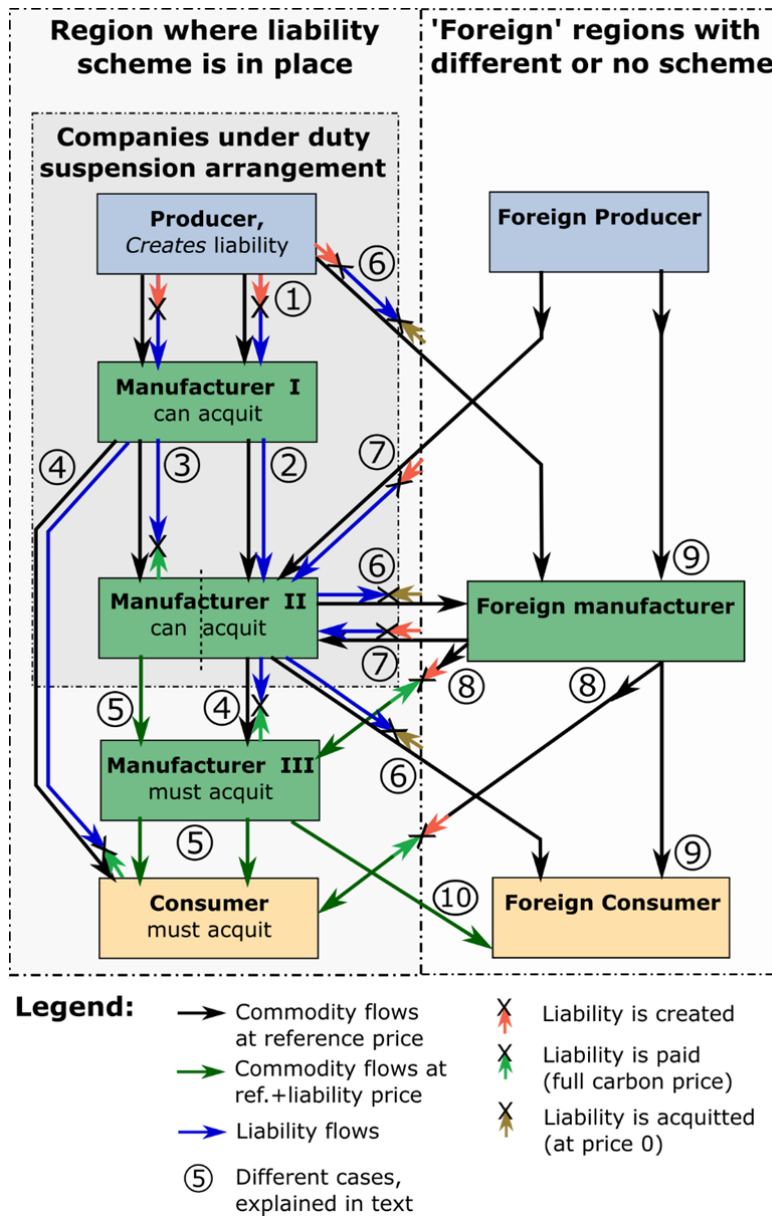

Figure 3: Scheme of commodity and liability flows under the inclusion of consumption. The different cases (1)-(10) are explained in the text above

Total liability linked to domestic production, consumption, imports and exports

In 2012, industry within the EU28 countries produced about 160 Mt of steel, 3.6 Mt of aluminium, 57 Mt of plastics, 100 Mt of paper, and 170 Mt of cement (Table 5). With the given EU-ETS emissions benchmarks and an assumed carbon price of 30 €/ton of CO₂, these production volumes correspond to liabilities of about 8500 MEUR for steel, 1400 MEUR for aluminium, 2500 MEUR for plastics, 1200 MEUR for paper, and 3600 MEUR for cement. The liabilities per ton of material differ substantially across materials, which is a result of differences in carbon intensity. For paper and cement the charge is 12 and 21 €/ton respectively, for plastics and steel 45 and 53 €/ton, and for aluminium about 385 €/ton.

Table 5: Material production, EU-ETS benchmarks, and total liabilities created, EU28, 2012. Data sources are listed in the methods section.

Material	Total production, EU28, 2012, Mt	EU-ETS benchmark t CO ₂ -eq/t	Liability per ton (EUR)	Total liability created within EU28 (MEUR)
Steel	160	1.780	53	8500
Aluminium	3.6	12.82	385	1400
Plastics	57	1.5	45	2500
Paper	100	0.4	12	1200
Cement	170	0.69	21	3600
Carbon price: EUR/t of CO₂	30		Sum	17200

The total volume of liabilities for the five materials in 2012 was about 17.000 MEUR. In addition to the liabilities for production, Table 6 shows our estimates of the liabilities created during import and acquitted during export. In import flows, aluminium- and steel-related liabilities each account for more than one third of the total. For export steel-related liabilities dominate with a share of more than 50%. The total trade-related liabilities roughly balance. Total liabilities (right column) were calculated as liabilities created plus import-related minus export-related liabilities. The first estimate of the magnitude of the total liabilities acquitted shows that total revenues of about 17.5 billion Euros would be generated with a carbon price of 30 €/ton and 2012 production levels. Of this amount, about 43% would stem from steel-related liabilities, followed by 20% for cement. Aluminium- and plastics-related liabilities would contribute with about 16% each, and paper about 6%.

Table 6: Total liabilities created and acquitted, EU28, 2012.

Material	Liability created within EU28 (MEUR)	Liability created during import (MEUR)	Liability acquitted during export (MEUR)	Liability paid by EU28 consumers (MEUR)
Steel	8500	3500	4450	7550
Aluminium	1400	3500	2200	2700
Plastics	2500	1700	1400	2800
Paper	1200	60	190	1050
Cement	3600	56	260	3400
Sum	17200	8800	8500	17500

With the given benchmarks and a carbon price of 30 €/t of CO₂, the material-related financial burden for final consumers within the EU would be in the range of 15-20 billion Euros.

The values presented in Tables 5 and 6 are only rough estimates, which depend on the actual material content of the traded commodities. Table 7 gives an impression of the possible variation of the trade-related liabilities as a result of variations in the material content of commodity groups. The sensitivity analysis showed that relative uncertainties of

±15% to ±25% are associated with variations in the content of steel, aluminium, and plastics of traded goods. This variation is a result of our ignorance of the exact material content of aggregated commodity groups such as motor vehicles, textile machines, or agricultural equipment. Paper and cement, which are mostly traded in pure form, exhibit no such variation.

In order to handle the variation of the material content in practice, one can imagine that a default material content is defined for each commodity group, which is then used to determine the default liability. If an importer can document a lower or different material composition, only then would the liabilities created be adjusted.

Table 7: Total liabilities incurred at point of import and acquitted at point of export, for low, medium, and high estimates of material content, respectively. Scope: EU28, production levels of 2012, carbon price 30 €/ton. All values in MEUR.

All values in MEUR	Import (incurred liabilities)			Export (acquitted liabilities)		
	low	medium	high	Low	medium	high
Steel	3041	3539	3734	3910	4459	4624
Aluminium	2669	3470	3958	1147	2196	2833
Plastics	1309	1684	2010	1126	1368	1529
Paper	59	59	59	186	187	187
Cement	56	57	57	257	261	265
Total	7136	8808	9818	6625	8470	9439

With the total amounts of liabilities known, we now turn our focus on how the liabilities per unit of product compare to commodity prices.

Prices changes for different commodity groups

With the average commodity prices, the EU-ETS benchmarks, and the carbon benchmark the relative liabilities for the five materials were calculated as the ratio between liability per ton and the material price per ton.

Table 8 summarizes our findings for commodity prices, the emissions benchmarks, the liabilities per ton, and the relative price changes that would result. Relative liabilities are lowest for paper (about 1.5%) and plastics (about 6%). Higher relative liabilities result for steel (11%), aluminium (20%), and cement (28%).

If the price of a commodity per kg is known, the emissions-related liability can be expressed in % of that price. If delivered to a final consumer or a company outside the duty suspension agreement (DSA), the liability would be paid and the price of the commodity would change accordingly.

Table 8. Relative liabilities for pure bulk commodities.

Material	Average price, 2007, MEUR/ton	EU-ETS benchmark t CO ₂ -eq/t	Liability per ton (EUR)	Relative liability / price change (%)
Steel	0.000475	1.780	53.4	11.2
Aluminium	0.001900	12.82	384.6	20.2
Plastics	0.0008250	1.5	45.0	5.5
Paper	0.000800	0.4	12.0	1.5
Cement	0.000075	0.69	20.7	27.6
Carbon price: EUR/t of CO₂	30			

Figure 4 shows typical relative liabilities (price changes) for selected commodities that contain only one material (Figure 4a) and manufactured goods that contain significant amounts of steel, aluminium, and plastics (Figure 4b). Relative price changes reach from about 28% for cement clinker¹ to about 8% for flat-rolled non-alloy steel, 17% for aluminium alloy plates, about 3% for ethylene polymers and approximately 1% for uncoated paper.

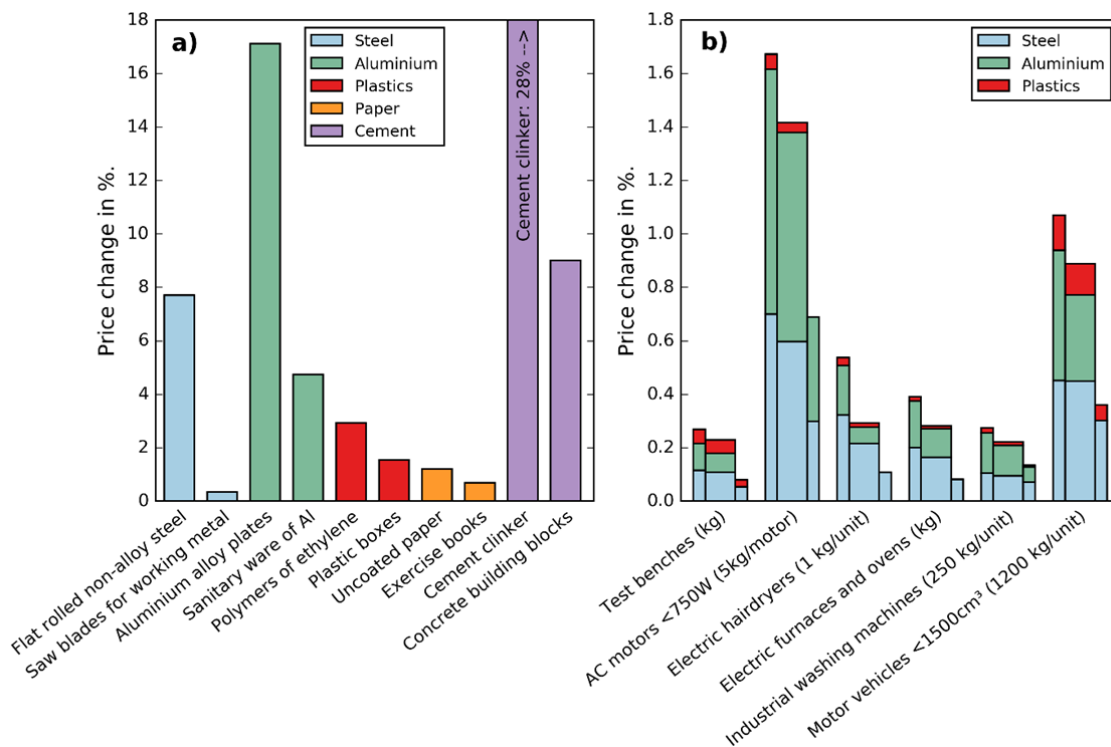

Figure 4. Typical relative liabilities (price changes) for selected commodities, production in the EU28 in 2012. In plot b) price changes are depicted for high (narrow column, left), medium (wide column, centre), and low (narrow column, right) values of material content.

¹ ProdCom reports a price of about 150 €/t, which is about twice the world market price of 75 €/t reported by the USGS and confirmed by experts. We disregarded the ProdCom data and took the USGS value as the reference.

Figure 4a also shows the relative liabilities (price changes) for manufactured goods that consist solely of one of the six materials being evaluated. These products show price changes between 9% for concrete building blocks (cement content estimated to be 20%), about 5% for sanitary ware of aluminium, about 0.3% of saw blades for working metal (steel content 95%), and roughly 1% for plastic boxes. The relative price changes of the manufactured products are consistently lower than those of the bulk materials, which is a consequence of the higher shares of value added in these products compared to the bulk materials.

Figure 4b shows the typical ranges of relative liabilities (price changes) for manufactured consumer products and industrial equipment. The price change for these types of goods typically lies between 0.1% and 1.5%. For most manufactured goods with significant liabilities, aluminium and steel are the largest contributors, followed by plastics. The sensitivity analysis shows that because of large possible variations in the material content of product groups, a direct consequence of their diversity, the resulting price changes form a range of possible values rather than specific fixed values.

To further illustrate the progression of liabilities along the value chain, we study the example of a typical European passenger vehicle of a weight of 1300 kg, a basic price of 10000 €, a steel content of 800 kg, an aluminium content of 100 kg, and a plastic content of 200 kg (Modaresi et al., 2014). We consider three stages of the value chain: raw material production where liabilities are created, component manufacture represented by gearbox and seat manufacturing, and the car manufacturing plant (Figure 5).

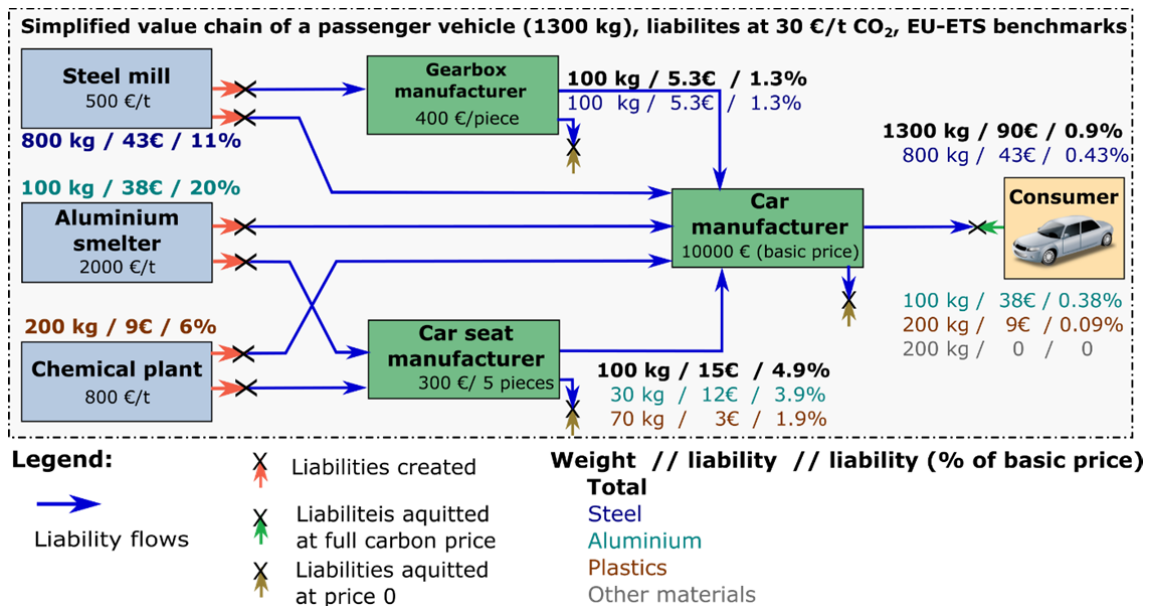

Figure 5. Simplified value chain of a passenger vehicle. Three materials (steel, aluminium, and plastics) and two components (gearbox and seats) are considered. The figure shows the material contained (in kg), the total liability (in €), and the liability as fraction of the basic price (in %) for the sum total (bold face), and for steel (dark blue), aluminium (light blue), and plastics (brown), respectively.

The relative liability decreases at every step in the value chain, as the share of cumulative valued added of the products' prices becomes larger. While finished steel has a relative liability of about 11%, the gearbox has one of about 1.3%, and in the car, steel-related liabilities account for only for 0.43% of the basic price. With current benchmarks and a carbon price of 30 €/t, each buyer of a car would have to pay for material-related liabilities of about 90 €, of which 43 € are associated with steel, 38 € with aluminium, and about 9 € with plastics. Because of the possible variations of the material composition of cars, these values are rough indicators only that show the order of magnitude of liabilities. The largest price signal is sent to the first users of finished materials, and these users often are also the ones who make the design choices; for example, the car seat manufacturer shown in Figure 5.

We now present the overview of expected commodity price changes for the entire EU28. Figure 6 shows a histogram plot of the number of ProdCom categories that experience a certain price change if sold to a consumer within the EU28. The EU ProdCom database contains data on production volumes, imports, and exports for 4047 commodity groups, both in in monetary units (EUR) and in physical units (kg or pieces) (Eurostat, 2013). ProdCom data can be used to estimate relative liabilities for only those groups where both physical and economic production data are reported.

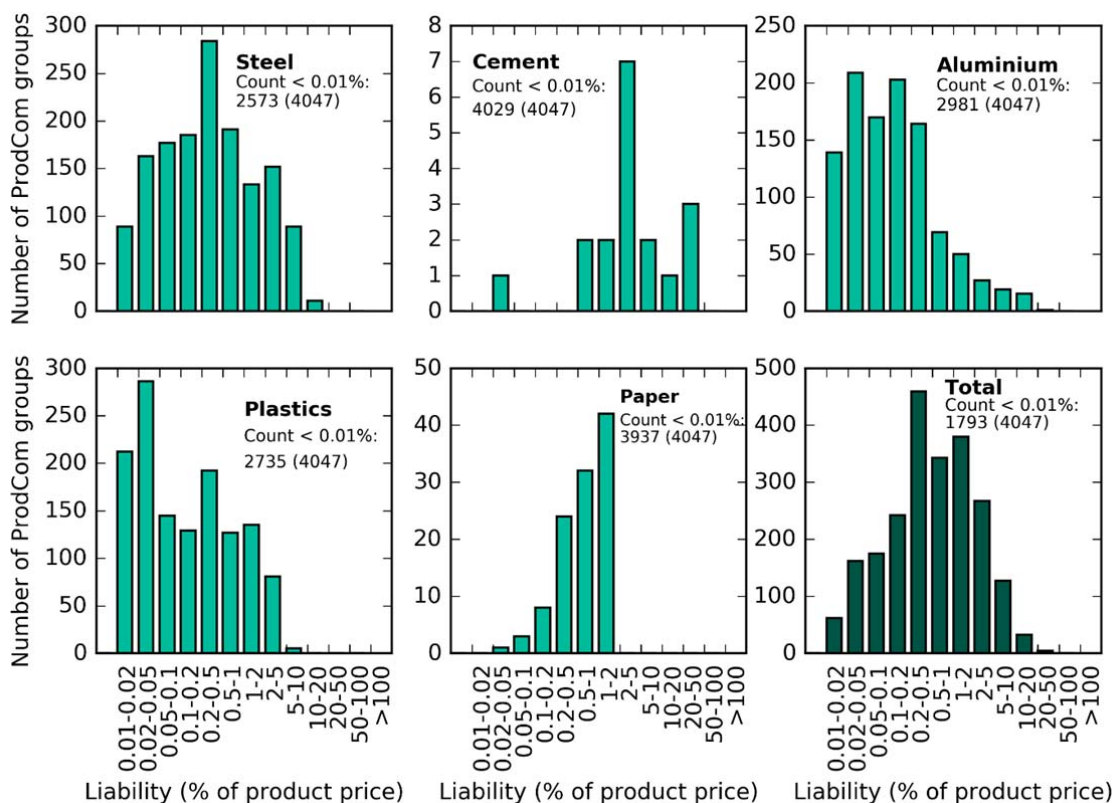

Figure 6. Histogram of the number of ProdCom groups with a certain relative liability (in %). Results are shown for the 2012 production flows within the EU28, five materials, and the sum total of the relative liabilities of the five materials.

This includes 3294 of 4047 groups for the production account. Out of the 4047 groups in the ProdCom database, 2573 groups for steel and 4029 groups for cement show a price change of 0 to 0.01%. The vast majority of the remaining groups for steel, aluminium, and plastics show price changes between 0.01 and 5%; these are groups where the materials were used in the manufacturing of products (metals and plastics). Cement and paper, which are often sold in pure form to final consumers (or concrete for cement), tend to carry higher relative liabilities.

The largest relative liabilities and associated price signals would occur for cement, with relative liabilities of up to 28%, followed by aluminium with up to 20%, steel with up to 11%, plastics with up to 6%, and paper with up to 2%. One can also say that cement is cheap compared to its embedded carbon liabilities, whereas plastics is already relatively expensive compared to its carbon intensity.

Table 9 shows the same information as displayed in Figure 6, in a histogram where the 4047 ProdCom groups are allocated into bins according to their relative liability (liability per kg in % of product price per kg). Results include total production, primary material production, import, and export flows and the relative liabilities associated with the five materials and the sum total, broken down in intervals from < 0.01% to 50%.

Table 9: The 4047 ProdCom groups sorted by liability per unit relative to price for the production flows of the EU28 in 2012.

Production	Steel, low	Steel, medium	Steel, high	Al, low	Al, medium	Al, high	Cement, low	Cement, medium	Cement, high	Total, low	Total, medium	Total, high
< 0.01%	2703	2573	2544	3818	2981	2906	4030	4029	4029	1897	1793	1780
0.01%-0.02%	82	89	75	25	139	91	0	0	0	108	62	39
0.02%-0.05%	187	163	153	45	209	190	1	1	0	196	162	132
0.05%-0.1%	154	177	174	34	170	173	0	0	1	233	175	156
0.1%-0.2%	193	185	192	28	203	188	0	0	0	275	242	223
0.2%-0.5%	250	284	310	30	164	233	0	0	0	420	459	441
0.5%-1%	144	191	191	15	69	120	2	2	1	293	343	377
1%-2%	104	133	150	8	50	59	3	2	1	270	380	422
2%-5%	131	152	154	13	27	44	6	7	7	210	267	290
5%-10%	87	89	93	15	19	26	2	2	3	113	127	145
10%-20%	12	11	11	15	15	16	0	1	2	28	33	38
20%-50%	0	0	0	1	1	1	3	3	3	4	4	4

The distribution in Table 9 gives a clear hint on that relatively few commodity groups include the bulk of the total liabilities, and Table 9 and Figure 6 show that relative liabilities are below 1% for more than 85% of all commodity groups.

Commodity groups with only one material – and with minute shares of materials

Table 10 shows the number of commodity groups whose material content lies above the four thresholds of 0, 0.1, 0.5, and 0.95, respectively. Results are given for the low, medium, and high estimate of material content, respectively.

The vast majority of the commodity groups with material content larger than 0.95 are the pure bulk material groups like ‘Tubes and pipes, of non-circular cross-section, seamless, and hollow profiles, seamless, of steel’ (24201400) or ‘Polyvinyl chloride, not mixed with any other substances, in primary forms’ (20163010). For aluminium, plastics, paper, and cement, the number of categories with pure materials (>0.95) is rather insensitive to the possible variations in material content. Steel represents an exception, as for the high material content estimate, 334 groups are included, which is 60 groups more than for the average estimate. The reason is that there are several groups of manufactured products, mostly machines, containing a very high average share of steel (around 0.8) and that can sometimes be made almost entirely out of steel. Examples include ‘Machines for working wire (excluding draw-benches, thread rolling machines)’ (28413450) or ‘Centrifugal pumps with a discharge outlet diameter > 15 mm, multi-stage (including self-priming)’ (28131460).

Table 10. Number of commodity groups in ProdCom in NACEv2 classification, whose material content exceeds 0, 0.1, 0.5, and 0.95 kg/kg, respectively. The total number of groups in the ProdCom NACEv2 classification is 4047. The table shows the counts for the lower (left), medium (middle, bold), and higher (right) estimates for material content.

	Total	Entries not 0	Entries > 0.1	Entries > 0.5	Entries > 0.95
Iron/steel		1699- 1832 -1832	1544- 1733 -1761	966- 1403 -1512	274- 274 -334
Al		297- 1387 -1387	71- 88 -360	35- 50 -50	26- 26 -32
Plastics	4047	1091- 1941 -1941	902- 1012 -1161	348- 400 -612	278- 278 -300
Paper		136- 136 -136	135- 136 -136	133- 133 -134	116- 116 -116
Cement		19- 20 -20	19- 19 -19	4- 4 -4	4- 4 -4

Table 10 also shows that less than half of the commodity groups have noteworthy concentrations of the five materials. If one would use a content of 10% as threshold for inclusion in the scheme, still, 1544-1761 commodity groups would have to be considered for steel, 902-1161 for plastics, 71-360 for aluminium, 135-136 for paper, and 19 for cement. Quite a large number of groups consists of more than 50% of a certain material, this affects 966-1512 groups for iron/steel, 35-50 for aluminium, 348-612 for plastics, about 134 for paper, and only 4 for cement.

Commodities with insignificant amount of the five materials covered by the consumption based charge mostly belong to one of the following groups: agricultural products (other than paper/pulp), chemicals (other than plastics), ceramics, nonferrous metals (other than aluminium), and services.

Commodity groups according to their contribution to total liability

Cement and aluminium lead the list of production-related liabilities, ranked by liabilities embedded for the EU28 in 2012. (See Table A1 in the Annex). Aluminium (unwrought, alloy bars, and rods) and steel (flat rolled) lead the list of import-related liabilities (Table A2 in the Annex). About 13 of the top fifty groups in the production table are finished steel commodities and about 10 groups are finished aluminium metal groups. About 15 out of 50 groups are manufactured products or parts thereof, led by 'weirs and lock-gates' (place 6, probably due to a mistake in the physical flow account), 'gear boxes and parts thereof' (place 8), and 'motor vehicles with petrol engines' (place 11).

More than 50% of the 4047 ProdCom commodity groups contribute with less than 100,000 EUR to the total production-related liabilities (Table 11). In contrast, the number of groups with production liabilities of 10 MEUR or more is limited to 252-298 for steel, 53-132 for aluminium, 131-175 for plastics, 30 for paper, and 12-13 for cement. Table 11 shows that there is at least one commodity group for each of the five materials that contains liabilities of 100 MEUR or more.

Table 11: The 4047 ProdCom groups sorted by amount of liability for the production flows inside the EU28 in 2012.

Production	Steel			Al			Cement			Total		
	low	medium	high	low	medium	high	low	medium	high	low	medium	high
< 0.1 MEUR	2926	2798	2761	3851	3210	3128	4031	4030	4030	2215	2056	2008
0.1-0.5 MEUR	304	330	329	63	351	303	1	0	0	478	426	390
0.5-1 MEUR	138	153	162	25	110	149	1	1	1	207	237	236
1-5 MEUR	324	350	353	41	228	265	2	2	2	486	532	559
5-10 MEUR	103	133	144	14	39	70	0	2	1	191	241	235
10-50 MEUR	162	183	196	26	64	79	3	2	2	306	360	410
50-100 MEUR	35	45	44	9	17	21	1	2	2	68	88	93
100-500 MEUR	48	48	51	11	21	24	5	5	6	79	86	92
500-1000 MEUR	6	6	6	5	5	6	1	1	1	12	16	18
> 1000 MEUR	1	1	1	2	2	2	2	2	2	5	5	6

We further explore the distribution of liabilities across commodity groups in Table 12, where we show the minimum number of ProdCom categories that need to be included in the scheme to cover the indicated percentage of total liability. These results were obtained by ranking all commodity groups by contained total liability for the five materials. Table 12 also shows the value of imports or exports that relates to the trade in these product categories.

Table 12. Result of a ranking of all 4047 commodity groups by the amount of liabilities contained. The table shows the minimum number of categories that cover a certain percentage of all liabilities contained in imported and exported commodities, and the value of trade in these product categories.

Percentage of liability	Import		Export	
	Number of ProdCom categories included	Value of imports included, billion EUR	Number of ProdCom categories included	Value of exports included, billion EUR
5	1	4	2	77
10	2	8	4	81
15	2	8	6	83
20	3	11	10	88
25	5	14	15	107
30	9	17	22	128
35	15	32	29	137
40	23	51	38	150
45	32	68	48	165
50	45	84	61	197
55	62	98	78	227
60	83	125	100	249
65	110	141	129	275
70	148	170	165	305
75	198	200	214	336
80	266	286	280	377
85	364	337	371	424
90	517	401	515	524
95	798	517	771	654
100	2251	750	2251	999

If the commodity groups with the largest associated liabilities were monitored first, 90% coverage of trade-related liabilities could be achieved by including between 500 and 550 groups. Since trade volumes can change quickly and other groups contain higher relative liabilities, the scheme should potentially not only include those groups with historically high total liabilities but also those groups with high relative liabilities, which we identify in the last step of our analysis.

Combined analysis

Finally, we summarize our findings on the distribution of liabilities across commodity groups and the possible relative price changes by showing how liabilities are distributed across imported (Figure 7) and exported (Figure 8) commodities.

All import and export flows are ranked according to their relative liability (in %) and then this relative liability was plotted over the cumulative imports and exports. This means that the area of each bar represents the total liabilities embedded in the trade of this particular group, broken down into the five materials studied.

In contrast to table 12, in Figures 7 and 8 also product groups are identified with a low overall size, but a significant liability measured as share of the product price.

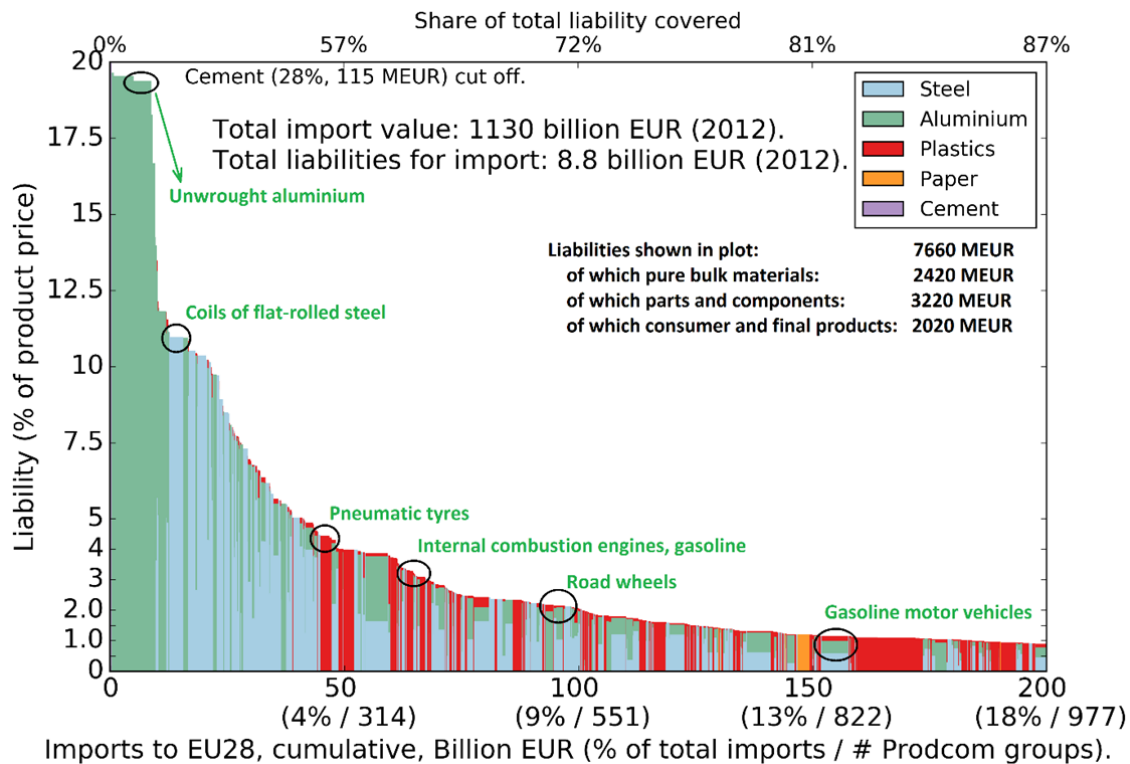

Figure 7. Imports into the EU28 in 2012, cumulative, sorted by relative liability or price change (%).

Steel (blue) and aluminium (green), as well as products consisting mostly thereof dominate the liabilities created during import and waived during export. Trade of plastics (red), and paper (orange) also plays a role as there are some commodity groups that consist entirely of these two materials.

Pure bulk material groups of cement, steel, and aluminium, with relative liabilities of more than 5%, are mostly found on the left side of the curves; parts and components, such as road wheels or pneumatic tyres, are found in the middle with relative liabilities between 1 and 2 %; and manufactured goods with a relative liabilities of below 1% can be found on the right side.

The liability as share of product price exceeds 1% in about 950 commodity groups that account together for 17% of imports. These 17% of imports comprise 86% of all import-related liabilities. To increase the coverage to 90% of all trade-related liabilities in imports, product categories with a liability share of product price exceeding 0,73% need to be included, accounting for about 1100 Prodcum commodity groups and 21% of total imports by value.

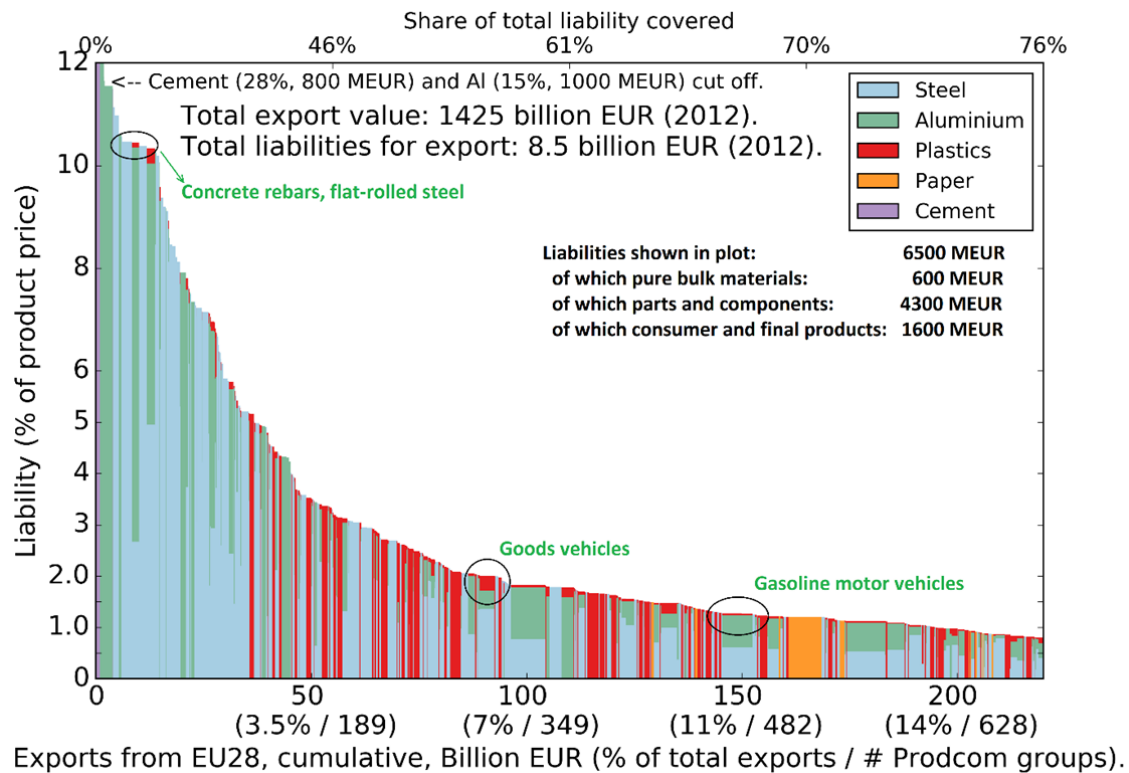

Figure 8. Exports from the EU28 in 2012, cumulative, sorted by relative liability (price change) (%).

For practical implementation it might be warranted to consider all import categories exceeding a product price increase threshold of, for example, 1%, and then to then add additional product categories exceeding the 0,73% threshold where this would be necessary to avoid incentives for shifting final assembly of products to foreign territory. Thus the total number of considered product categories may be between 900 and 1100 comprising 17% to 21% of total imports. If initially coverage is limited to a sub-set of the materials that comprise the bulk of emissions and thus also mitigation potential, for example steel, aluminium and cement, then the number and share of product categories considered could be reduced.

5. Conclusion

We studied how liabilities from including the consumption of five materials (steel, aluminium, plastics, paper, and cement) in the EU-ETS are distributed across the 4047 commodity groups, and how commodity prices would change if liabilities were to be paid by final consumers.

With current EU-ETS benchmarks and a carbon price of 30 €/ton of CO₂, the total liability attributed to European consumers would be in the order of 17 billion € per year. Import- and export-related liabilities roughly balance, they account each for about 8.5 billion € per

year or roughly 50% of the total amount of liabilities acquitted by consumers within the EU28.

For the manufactured goods, liabilities and price changes were computed using physical ProdCom data, which are often incomplete and which had to be converted from per unit to per kg. If price changes were higher than prices changes for pure bulk material commodities, these results were considered outliers and they were replaced by the average price change for the aggregated commodity group on the 4-digit NACE level.

We found that liabilities are unequally distributed across commodity groups. Expressed in terms of commodity prices, liabilities for finished steel, finished aluminium, and cement product groups are between 11% and 28%. Relative liabilities for most manufactured goods are below 2%.

For domestically manufactured products, the liability is traced from the inputs of the basic materials and will thus be accurately reflected. For imported products, a default material content could be set for each group, and liabilities would be determined using that content. Lower liabilities would only be created if the material content is reported.

A de-minimis rule reduces administrative requirements by defining product categories for which at the time of import no liability for the consumption charge is incurred. This should both retain effective incentives and avoid undue discrimination between domestic and foreign produced materials. For the five materials considered we find that coverage of 85%-90% of the liability for the consumption charge relating to imports can be ensured if 900-1100 ProdCom product categories are covered comprising 17%-21% of imports by value. If, during an initial stage of the scheme, coverage was limited to a sub-set of the materials that comprise the bulk of emissions and thus also mitigation potential, for example steel, aluminium and cement, then the number and share of product categories considered could be reduced.

Roughly 50% of the groups in the monitored fraction are pure bulk material groups, which contain 95% or more of one material and whose liabilities can be determined directly from the commodity weight. For the remaining groups material content exhibits significant variations, especially within the groups for manufactured products. The uncertainty of material content for manufactured goods is a result of the inhomogeneity within the already highly disaggregated product categories.

Overall we find that availability and quality of data is well suited to support a policy design that allocates responsibility for carbon to consumers based on benchmarks. Anticipation of this charge allocated to carbon intensive material choices also creates incentives along the value chain. Responsibility for emissions from materials production exceeding the benchmark needs to remain with producers that therefore need to remain covered in the emission trading systems.

Annex

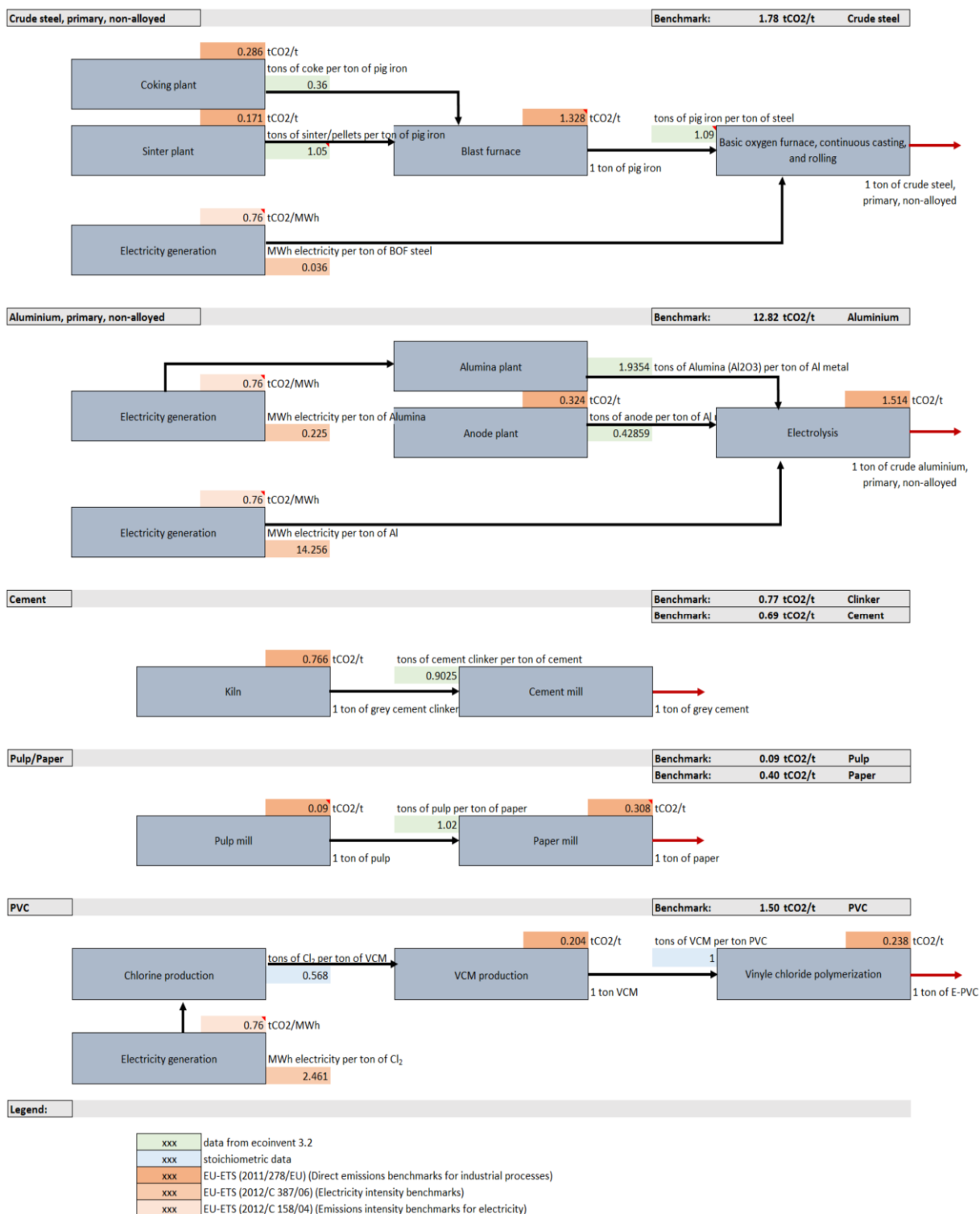

Figure A1. System definition for the derivation of product-specific emissions benchmarks for the five materials studied. The process chains were built using data from ecoinvent (Ecoinvent Centre, 2014) and stoichiometric information. The EU-ETS emissions benchmarks for processes define the scope of the process chains and the emissions multipliers.

Table A1. Top 50 commodity groups, ranked by liabilities created at the **moment of production**, for the five materials. Unit: MEUR. Scope: EU28, 2012. Column 2 shows the ProdCom code. **Note:** This table comprises consecutive steps of the value chain and therefore contains double-counted liabilities.

Liability, production, MEUR, EU28, 2012	Steel	Al	Plast.	Paper	Cement	TOTAL
Portland cement	23511210	0	0	0	2986	2986
Ready-mixed concrete	23631000	0	0	0	2119	2119
Aluminium alloy plates	24422450	0	1295	0	0	1295
Flat-rolled products of iron	24103110	1268	0	0	0	1268
Unwrought aluminium alloys	24421155	0	1038	0	0	1038
Maritime and waterway structs.	25112355	915	0	0	0	915
Aluminium alloy bars, rods	24422250	0	910	0	0	910
Gear boxes and their parts	29323033	430	442	26	0	898
Hot dipped metal coated sheet	24105130	821	0	0	0	821
Hot rolled concrete reinforcing	24106210	814	0	0	0	814
Motor vehicles with a petrol eng.	29102230	367	264	95	0	726
Ingots, other primary forms	24102120	711	0	0	0	711
Aluminium plates, sheets	24422430	0	668	0	0	668
Motor vehicles with a diesel	29102330	328	236	85	0	649
Aluminium structure and parts	25112370	0	647	0	0	647
Unwrought aluminium alloys	24421153	0	639	0	0	639
Other hydraulic cements	23511290	0	0	0	629	629
Aluminium doors	25121050	0	597	0	0	597
Other parts and accessories	29323090	281	289	17	0	586
Uncoated cold rolled sheet	24104120	547	0	0	0	547
Uncoated cold rolled sheet	24104110	541	0	0	0	541
"Instruments and appliances	32501370	254	110	128	0	492
Other wire rod	24106190	478	0	0	0	478
"Casks, drums, cans, boxes	25921240	82	373	0	0	455
Connections and contacts	27331370	180	235	11	0	426
Parts and of vehicle bodies	29322090	198	204	12	0	414
Flat-rolled products, of iron	24103150	404	0	0	0	404
Aluminium foil of a thickness	24422500	0	395	0	0	395
Polypropylene, in primary forms	20165130	0	0	388	0	388
Flat semi-finished products	24102110	368	0	0	0	368
Other ingots, primary forms	24102122	357	0	0	0	357
Flat-rolled products	24103510	335	0	0	0	335
Base metal closures, stoppers	25921370	60	275	0	0	335
Light metal castings for vehicles	24531010	0	335	0	0	335
Prefabricated structural comp.	23611200	0	0	0	332	332
Plastic carboys, bottles, flasks	22221450	0	0	330	0	330
Goods vehicles with a diesel	29104110	214	58	45	0	316
Vehicles with spark-ignition eng.	29102100	158	114	41	0	313
Iron or steel doors, thresholds	25121030	308	0	0	0	308
Ingots, other primary forms	24102121	307	0	0	0	307
Hot rolled flat products in coils	24103320	306	0	0	0	306
Prefabricated buildings, of iron	25111030	286	0	0	0	286
Articles for the conveyance	22221950	0	0	277	0	277
Other electric conductors	27321380	0	240	28	0	269
Suspension systems and parts	29323050	127	130	8	0	265
Polyethylene	20161050	0	0	263	0	263
Sacks and bags of polymers	22221100	0	0	262	0	262
Ingots, other primary forms	24102320	259	0	0	0	259
Unwrought non-alloy aluminium	24421130	0	259	0	0	259
Other structures of steel	25112350	257	0	0	0	257

Table A2. Top 50 commodity groups, ranked by liabilities created at the moment of import, for six materials. Unit: MEUR. Scope: EU28, 2012. Column 2 shows the ProdCom code.

Liability, import, MEUR, EU28, 2012	Steel	Al	Plast.	Paper	Cement	TOTAL
Unwrought aluminium alloys 24421153	0	824	0	0	0	824
Unwrought non-alloy aluminium 24421130	0	748	0	0	0	748
Flat semi-finished products 24102110	315	0	0	0	0	315
Flat-rolled products of iron 24103110	187	0	0	0	0	187
Aluminium alloy plates, sheets 24422450	0	181	0	0	0	181
Aluminium alloy bars, rods 24422250	0	110	0	0	0	110
Pig iron and spiegeleisen 24101100	98	0	0	0	0	98
Aluminium plates, sheets 24422430	0	95	0	0	0	95
Non-alloy aluminium wire 24422330	0	92	0	0	0	92
T-shirts, singlets and vests 14143000	0	0	85	0	0	85
Flat-rolled products, of iron 24103150	80	0	0	0	0	80
Goods vehicles with diesel eng. 29104110	54	14	11	0	0	79
Aluminium foil 24422500	0	75	0	0	0	75
Ferro-chromium 24101260	74	0	0	0	0	74
Hot dipped metal coated sheet 24105130	71	0	0	0	0	71
Vehicles with spark-ignition eng. 29102100	33	24	9	0	0	66
Uncoated cold rolled sheet 241041Z0	60	0	0	0	0	60
Articles of aluminium, n.e.c. 25992955	0	59	0	0	0	59
Motor vehicles with diesel eng. 29102330	29	21	8	0	0	58
Ferrous products 24101300	57	0	0	0	0	57
Ingots, other primary forms 241021Z0	52	0	0	0	0	52
Static converters 27115070	22	28	1	0	0	51
Parts for machines 27116100	20	27	1	0	0	48
Polyethylene 20161050	0	0	47	0	0	47
Other transformers, n.e.c. 27114240	19	25	1	0	0	46
Organic coated sheet 24105140	44	0	0	0	0	44
Motor vehicles with petrol eng. 29102230	22	16	6	0	0	44
Unwrought aluminium alloys 24421155	0	44	0	0	0	44
Linear polyethylene 20161035	0	0	44	0	0	44
Parts suitable for machines 28114200	21	22	1	0	0	44
Agrarian tyres; other 22111400	0	0	44	0	0	44
New pneumatic rubber tyres 22111100	0	0	43	0	0	43
Synthetic rubber 20171090	0	0	39	0	0	39
Parts of machinery of HS 84.25 28221930	31	6	1	0	0	38
Brakes and servo-brakes 29323020	18	18	1	0	0	38
Polypropylene, in primary forms 20165130	0	0	37	0	0	37
Metal furniture 31091100	24	12	0	0	0	36
Other electric conductors 27321380	0	31	4	0	0	35
Parts and accessories 28414030	23	10	1	0	0	34
Women's or girls' briefs 14141420	0	0	33	0	0	33
Hot rolled concrete rebar 24106210	33	0	0	0	0	33
Other wire rod (non-alloy steel) 24106190	32	0	0	0	0	32
Portland cement 23511210	0	0	0	0	32	32
Parts of air and vacuum pumps 28133200	23	6	1	0	0	31
Women's or girls' jerseys 14391072	0	0	29	0	0	29
Aluminium structure and parts 25112370	0	29	0	0	0	29
Electric motors 27111010	12	16	1	0	0	29
Road wheels and parts 29323040	13	14	1	0	0	28
Parts for earthmoving equipmt. 28926150	18	8	1	0	0	27
Sum total	1513	2557	450	0	32	4552

Table A3. Top 50 commodity groups, ranked by liabilities created at the moment of export, for six materials. Unit: MEUR. Scope: EU28, 2012. Column 2 shows the ProdCom code.

Liability, export, MEUR, EU28, 2012	Steel	Al	Plast.	Paper	Cement	TOTAL
Motor vehicles with petrol eng. 29102230	188	135	49	0	0	372
Hot rolled concrete rebar 24106210	240	0	0	0	0	240
Aluminium alloy plates, sheets 24422450	0	224	0	0	0	224
Flat-rolled products of iron 24103110	185	0	0	0	0	185
Portland cement 23511210	0	0	0	0	151	151
Industrial use engines 28111375	36	103	1	0	0	140
Other trailers and semi-trailers 29202300	65	67	4	0	0	135
Flat-rolled products, of iron 24103150	107	0	0	0	0	107
Flat semi-finished products 24102110	105	0	0	0	0	105
Aluminium foil 24422500	0	101	0	0	0	101
Hot dipped metal coated sheet 24105130	91	0	0	0	0	91
Cement clinker 23511100	0	0	0	0	83	83
Motor vehicles with diesel eng. 29102330	40	29	10	0	0	80
Line pipe 24202110	79	0	0	0	0	79
Goods vehicles 29104140	46	13	10	0	0	69
Parts 28114200	33	34	2	0	0	69
Ingots, other primary forms 24102120	66	0	0	0	0	66
Aluminium alloy bars, rods 24422250	0	61	0	0	0	61
Uncoated cold rolled sheet 24104120	60	0	0	0	0	60
Alternators 27112670	25	33	2	0	0	59
Spark-ignition engines 39990022	28	29	2	0	0	58
Vehicles 29102100	29	21	8	0	0	58
Tinplate, other tinned sheet 24105110	58	0	0	0	0	58
Other wire rod 24106190	57	0	0	0	0	57
Aluminium plates, sheets 24422430	0	57	0	0	0	57
H-sections 24107130	56	0	0	0	0	56
Polyvinyl chloride 20163010	0	0	54	0	0	54
Goods vehicles with diesel eng. 29104110	36	10	8	0	0	53
Articles of aluminium, n.e.c. 25992955	0	52	0	0	0	52
Parts suitable for machines 27116100	22	29	1	0	0	52
Casing, tubing and drill pipe 24201250	52	0	0	0	0	52
Unwrought aluminium alloys 24421155	0	52	0	0	0	52
Maritime structures 25112355	50	0	0	0	0	50
Other electric conductors 27321380	0	44	5	0	0	49
Railway material (of steel) 24107500	48	0	0	0	0	48
Flat-rolled products 24103510	48	0	0	0	0	48
I-sections 24107120	45	0	0	0	0	45
Multi-phase AC motors 27112590	19	25	1	0	0	45
Polyethylene 20161050	0	0	45	0	0	45
Flat-rolled products 24103530	44	0	0	0	0	44
Vehicle compression-ign. engs. 29101300	21	21	1	0	0	43
Polymers of propylene 20165150	0	0	42	0	0	42
Bodies for lorries, vans, buses 29201050	20	20	1	0	0	41
Parts for trailers, semi-trailers 29203090	19	20	1	0	0	40
Tubes and pipes 24201370	39	0	0	0	0	39
Liquid dielectric transformers 27114180	16	21	1	0	0	38
Acrylic polymers 20165390	0	0	38	0	0	38
Aluminium structure and parts 25112370	0	38	0	0	0	38
Synthetic rubber 20171090	0	0	38	0	0	38
Sum total	2070	1237	360	0	234	3901

References

- Allwood, J. M., Cullen, J. M., Carruth, M. A., Cooper, D. R., McBrien, M., Milford, R. L., ... Patel, A. C. H. (2012). *Sustainable Materials: with both eyes open*. Cambridge, UK: UIT Cambridge, UK.
- Ecoinvent Centre. (2014). ecoinvent Version 3. Dübendorf, Switzerland. Retrieved May 10, 2014, from <http://www.ecoinvent.org/database/ecoinvent-version-3/>
- European Commission. (2011). *Commission decision, of 27 April 2011, determining transitional Union-wide rules for harmonised free allocation of emission allowances pursuant to Article 10a of Directive 2003/87/EC of the European Parliament and of the Council, Official Journal of the E*. Brussels.
- European Commission. (2012a). *Communication C387 from the Commission amending the Communication from the Commission Guidelines on certain State aid measures in the context of the greenhouse gas emission allowance trading scheme post-2012*. Brussels.
- European Commission. (2012b). *Guidelines on certain State aid measures in the context of the greenhouse gas emission allowance trading scheme post 2012*.
- European Commission. (2016). Carbon Leakage. Retrieved February 2, 2016, from http://ec.europa.eu/clima/policies/ets/cap/leakage/index_en.htm
- Eurostat. (2013). Prodcom - Statistics by Product. Retrieved August 30, 2013, from <http://epp.eurostat.ec.europa.eu/portal/page/portal/prodcom/introduction>
- Graedel, T. E., Van Beers, D., Bertram, M., Fuse, K., Gordon, R. B., Gritsinin, A., ... Vexler, D. (2004). Multilevel cycle of anthropogenic copper. *Environmental Science & Technology*, 38(4), 1242–1252.
- Guenther, E., Jasch, C., Schmidt, M., Wagner, B., & Huisingsh, D. (2012). Material Flow Cost Accounting. *Journal of Cleaner Production*, 29-30(2012), 291–292. doi:10.1016/j.jclepro.2012.01.025
- Johnson, J., Schewel, L., & Graedel, T. E. (2006). The Contemporary Anthropogenic Chromium Cycle. *Environmental Science and Technology*, 40(22), 7060–7069.
- Kytzia, S., Faist, M., & Baccini, P. (2004). Economically extended—MFA: a material flow approach for a better understanding of food production chain. *Journal of Cleaner Production*, 12(8-10), 877–889. doi:10.1016/j.jclepro.2004.02.004
- Liu, G., & Müller, D. B. (2013). Centennial evolution of aluminum in-use stocks on our aluminized planet. *Environmental Science & Technology*, 47(9), 4882–8. doi:10.1021/es305108p
- Modaresi, R., Pauliuk, S., Løvik, A. N., & Müller, D. B. (2014). Global carbon benefits of material substitution in passenger cars until 2050 and the impact on the steel and aluminum industries. *Environmental Science & Technology*, 48(18), 10776–10784. doi:10.1021/es502930w
- Müller, D. B., Liu, G., Løvik, A. N., Modaresi, R., Pauliuk, S., Steinhoff, F. S., & Brattebø, H. (2013). Carbon emissions of infrastructure development. *Environmental Science & Technology*, 47(20), 11739–46. doi:10.1021/es402618m
- Neuhoff, K., Ismer, R., Acworth, W., Ancygier, A., Haußner, M., Fischer, C., ... Zipperer, V. (2016). *Inclusion of Consumption of carbon intensive materials in emissions trading – An option for carbon pricing post-2020*. Climate Strategies Report (forthcoming), London, UK.
- Pauliuk, S., Majeau-Bettez, G., & Müller, D. B. (2015). A General System Structure and Accounting Framework for Socioeconomic Metabolism. *Journal of Industrial Ecology*, 19(5), 728–741. doi:DOI: 10.1111/jiec.12306
- Pauliuk, S., Wang, T., & Müller, D. B. (2013). Steel all over the world: Estimating in-use stocks of iron for 200 countries. *Resources, Conservation and Recycling*, 71, 22–30. doi:10.1016/j.resconrec.2012.11.008
- Schmidt, A., Götze, U., & Sygulla, R. (2014). Extending the scope of Material Flow Cost Accounting – methodical refinements and use case. *Journal of Cleaner Production*, 1–13. doi:10.1016/j.jclepro.2014.10.039
- Schmidt, M. (2014). The interpretation and extension of Material Flow Cost Accounting (MFCA) in the context of environmental material flow analysis. *Journal of Cleaner Production*, 1–10. doi:10.1016/j.jclepro.2014.11.038