

Yuguchi, Kiyotaka

## Conference Paper

# What is the role of the mobile operators in the 5G mobile communications?

26th European Regional Conference of the International Telecommunications Society (ITS):  
"What Next for European Telecommunications?", Madrid, Spain, 24th-27th June, 2015

### Provided in Cooperation with:

International Telecommunications Society (ITS)

*Suggested Citation:* Yuguchi, Kiyotaka (2015) : What is the role of the mobile operators in the 5G mobile communications?, 26th European Regional Conference of the International Telecommunications Society (ITS): "What Next for European Telecommunications?", Madrid, Spain, 24th-27th June, 2015, International Telecommunications Society (ITS), Calgary

This Version is available at:

<https://hdl.handle.net/10419/127200>

### Standard-Nutzungsbedingungen:

Die Dokumente auf EconStor dürfen zu eigenen wissenschaftlichen Zwecken und zum Privatgebrauch gespeichert und kopiert werden.

Sie dürfen die Dokumente nicht für öffentliche oder kommerzielle Zwecke vervielfältigen, öffentlich ausstellen, öffentlich zugänglich machen, vertreiben oder anderweitig nutzen.

Sofern die Verfasser die Dokumente unter Open-Content-Lizenzen (insbesondere CC-Lizenzen) zur Verfügung gestellt haben sollten, gelten abweichend von diesen Nutzungsbedingungen die in der dort genannten Lizenz gewährten Nutzungsrechte.

### Terms of use:

*Documents in EconStor may be saved and copied for your personal and scholarly purposes.*

*You are not to copy documents for public or commercial purposes, to exhibit the documents publicly, to make them publicly available on the internet, or to distribute or otherwise use the documents in public.*

*If the documents have been made available under an Open Content Licence (especially Creative Commons Licences), you may exercise further usage rights as specified in the indicated licence.*

# “What is the role of the mobile operators in the 5G mobile communications?”

Kiyotaka YUGUCHI (Dr. /Mr.)

Professor, Sagami Women's University

Bunkyo 2-1-1, Minami-ku, Sagami-hara City, Kanagawa, 252-0383, JAPAN

k-yuguchi@star.sagami-wu.ac.jp

Keywords: Spectrum Policy, 5G, Mobile Network Operators, Licensed Shared Access

## 1. Introduction

Up to the 4<sup>th</sup> generation mobile communications, the mobile operators have constructed their private networks by themselves even though they have partially used the WiFi networks to release heavy traffic from their own networks. However, in the 5<sup>th</sup> generation mobile communications (5G), the operators will be demanded to manage huge data transmission and then will be compelled to combine their own constructed networks with many other different networks under the third party's construction and control. In an extreme case, the operators may own their network no more and rent third parties' networks. The 5G mobile operators will cease to be mobile network operators (MNO) and become mobile virtual (MVNO) as a result.

In this situation, who will invest in the networks? It is necessary to obtain a wide bandwidth such as several hundred MHz or several GHz of bandwidth to transmit huge data. Such a broadband can be assured only in a very high frequency band like the 60 GHz band. Nature of the radio wave to be considered, the signals attain a few hundred meters. The operators should set up base stations very densely and pay for not only the base stations but also construction and operation of their backbone.

In the central cities, coffee shops and railway stations will provide data communication services for their own customers and be willing to join in the several operators' networks at the same time. However, in the suburban areas and the rural areas such a voluntary provider may not appear. The operators may construct their networks on their own account and/or by receiving the public subvention, as long as such an investment attracts their customers. The efficiency and effectiveness of the investment to be considered, each operator may share the others' infrastructures. Therefore technological differences will disappear among the 5G operators. The SIM cards have already been released from the mobile handsets provided by the mobile operators and then consumers can choose their favorite handsets. Price, coverage and facility of transmission (i.e. speed) may be determinants for choice of the operators.

Under this business environment, the regulators should revise their spectrum assignment policy. Up to now, the regulators have assigned dedicated radio frequency band to mobile operators on the auction basis or on the economic value basis. However, in the 5G system, a vast band will be exclusively assigned to many small and very local providers in the city centers and be shared by plural operators in the suburban and rural areas. New schemes such as the Licensed Shared Access (LSA) and Authorized Shared Access (ASA) are proposed. G. Pogorel and E. Bohlin (2014) summarized the policy trend, debate and benefit. They appreciated spectrum pricing systems such as the Administrative Incentive Pricing (AIP) in the U.K., and suggested to create a spectrum pricing adaptable to the LSA and the ASA. Unfortunately, they did not show clear methods for the pricing and only implied that the appropriate price should exist between bids in the actual auctions and the AIP.

In my presentation, I focus on the mobile operators' trade-off between the technological investment and the spectrum acquisition, which was theoretically shown in K. Yuguchi (2013). In addition, I also focus on the option value of the specific spectrum usages under the future uncertainty in spectrum provision and operators' uses. The idea of the option value was historically constructed in the environmental economy and almost completed in the 1980s. This idea was a little different of the argument of the real option. I have already suggested using the idea of the option value for spectrum pricing in my presentation at the 6<sup>th</sup> ITS Africa, Australasia and Asia Regional Conference in Perth in 2013. Here I mixed these two ideas and will show an appropriate calculation model for the LSA and the ASA. My model will show the level of spectrum prices more accurately than the G. Pogorel and E. Bohlin [2014]. Probably this theoretical model may contribute the recent debates on the LSA and the ASA from the pricing approach.

## **2. Paradigm Shift**

Up to the 3<sup>rd</sup> generation mobile communications, we have recognized the narrowed bandwidth as a typical technological method of the efficient use of spectrum. However, since the 4<sup>th</sup> generation mobile communications, we understand that transmission with a very broadband for a very short time makes an efficient spectrum usage. There are a great number of spectrum users with a wide variety of purposes in the most useful bands of spectrum, i.e. below 6GHz, and thus it is very difficult for every user to occupy a very huge bandwidth by itself. To ensure this new type of efficient transmission method, the operators may choose either of two technologies;

- Ultra Wide Band (UWB)

- Career aggregation

### (1) UWB

If the UWB technology and its kind are introduced as one of the 5G systems, spectrum will be used in a multi-layered way and will be separated at the level of the power and the interference tolerance. The mobile operators will construct and manage a single network of the UWB technology. They will negotiate with other multi-layered users concerned. In this case, the mobile operators will act as MNOs and will invite some MVNOs in their network as their traditional business model. They can control the quality of their services by themselves, and thus they may find easily the value of their spectrum. Necessity of negotiations with other spectrum users considered, the value may vary on the basis of the transaction costs, i.e. the number of spectrum sharing users. As the number increases, the value will decrease due to the time and the real costs of arrangements.

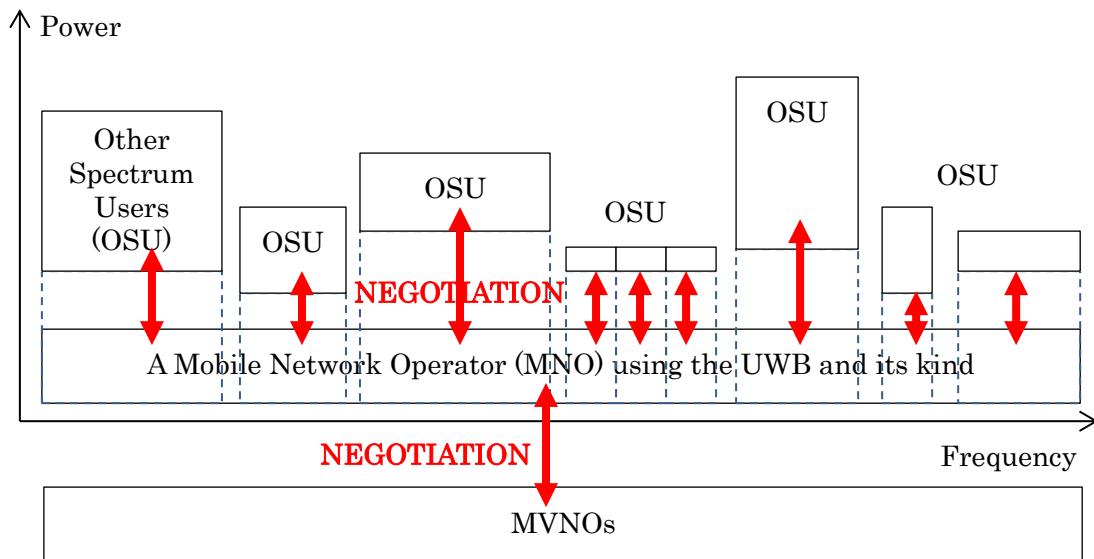

[Figure 1] Spectrum usage model adopting the UWB technology and its kind

### (2) Career aggregation

Actually, many different spectrum users coexist in the most useful bands of spectrum, i.e. below 6GHz, and thus it is impossible for the national spectrum management authorities to prepare a large continuous bandwidth. As a result, operators must use and aggregate several fragmented bands to ensure a necessary bandwidth for high data rate transmission. For example, [table 1] shows spectrum assignment by group of mobile operators in Japan.

[Table 1] Spectrum assignment by group of mobile operators in Japan

Bands of Frequency	700 MHz	800 MHz	900 MHz	1.5 GHz	1.7 GHz	2GHz	2.5 GHz	3.5 GHz	Total	Number of Subscribers Sep.2013
System bandwidth	FDD 30MHz×2	FDD 30MHz×2	FDD 15MHz×2	FDD 35MHz×2	FDD 35MHz×2	FDD 60MHz×2 TDD 31.2MHz	TDD 100MHz	TDD 120MHz		
NTT DoCoMo	LTE 20MHz	3G/LTE 30MHz		LTE 30MHz	3G 40MHz	3G/LTE 40MHz		LTE-A 40MHz	200 MHz	61.77M
<b>KDDI GROUP</b>										
au	LTE 20MHz	3G/LTE 30MHz		LTE 20MHz		3G/LTE 40MHz		LTE-A 40MHz	150 MHz	39.05M
UQ Communications							WiMAX 2 50MHz		50 MHz	4.28M
<b>SOFTBANK GROUP</b>										
Softbank			3G/LTE 30MHz	3G 20MHz		3G/LTE 40MHz		LTE-A 40MHz	130 MHz	34.07M
EMobile	LTE 20MHz				3G/LTE 30MHz				50 MHz	4.41M
Wireless City Planning							AXGP 30MHz		30 MHz	2.08M
Willcom						PHS 31.2 MHz			31.2 MHz	5.31M

Data: Ministry of Internal affairs and Communications (2014).

The author adds the result of the spectrum assignment for the 4G (3.5GHz band)

'M' means million.

If mobile operators construct their networks composed of many fragmented exclusive bands on several bands of spectrum, they will aggregate these bands by themselves to provide their services. Actually, the MVNOs generally use a single MSO's network. However every MNO adopt the same technology for the 5G, the MVNOs will not choose a single MNO's network anymore. The MVNOs may combine several MNO's networks to produce their required services; i.e. the highest speed service, the cheapest service and/or the best mix service between the speed and the price according to clients' location and/or needs. The MVNOs will become like freight forwarders and travel agents. The MSOs may really fall into a status of the dump pipe providers and face fierce competition. One of the key technologies to realize this type of market is the software radio. This technology has already been introduced in some devices. However, in the 5G devices, the software radio should be adaptable to very

wide bandwidth.

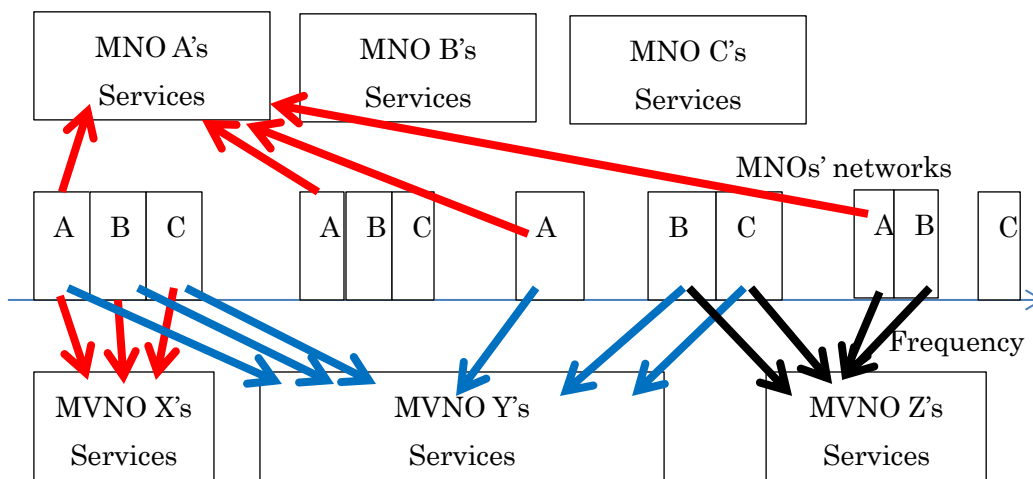

[Figure 2] Spectrum usage model adopting the Carrier aggregation Systems

### 3. Value of Shared Spectrum

If national spectrum management authorities introduce the shared spectrum access scheme, a next problem will be on the license fee. In my model, this problem may come from the spectrum usage model adopting the UWB technology and its kind. Traditionally licensees can use the spectrum exclusively, especially when the spectrum is assigned by auction. Once the shared spectrum access scheme is introduced, the existent licensees may face some restrictions on their future use of assigned spectrum. There exists uncertainty.

How to introduce the uncertainty into the pricing/valuing model of the band of frequency? Recent outputs in info-communications economics have shown usefulness of the real option theory. The theory shows when the investment should be done, and how much the value of the project increases by deferring the investment in order to decrease risk of the future under an uncertain environment in revenue. Ironically, this theory ensures the reverse trade-off, i.e. higher auction bids invite delay in the introduction of new services. It was said that higher auction bids lead early beginning of the new services in order to rapidly return the huge payment of the bid. In addition, each existent spectrum user faces uncertainty not only in its demand for the spectrum due to volatility of its revenue, but also in supply of the spectrum resources.

The traditional option value theory in environmental economics shows the additional value to mitigate the risk of loss of supply in certain goods under uncertainty

in demand for the goods. B.A. Weisbrod (1964) introduced firstly the idea of the option value in the context of preservation of a local railway. Its clear definition and its economic effects were given by some economists in 1960s and 1970s, and finally the theory was completed by A.M Freeman III (1984) (1986).

According to A.M Freeman III (1984) (1986), the option value is defined as the incremental value obtained by purchase of an option through amelioration of possibility of the future supply under demand uncertainty of the specific good or service in the future, and mathematically defined in the following model.

Suppose that a good or service like a national park or a local transport service, which a consumer does not use actually but has intention to use in the long future. Possibility of future supply of the good is 'p' ( $0 < p < 1$ ) before purchase of an option, and will be ameliorated to 'p'+s' ( $0 < s < 1$ ,  $0 < p+s < 1$ ) after purchase of the option. These possibilities are subjective. Suppose two situations with and without the good or service.

**[Table 2] Definition of the Option Value of the environmental/social goods and services**

The good or service will	Possibility <u>Before</u> purchase of the option	Possibility <u>After</u> purchase of the option	Income	Price system	The good or service	Indirect utility function
Be supplied	p	p+s	Y <sub>1</sub>	P <sub>1</sub>	G	U <sub>1</sub> (Y <sub>1</sub> , P <sub>1</sub> , G)
Not be supplied	1-p	1-p-s	Y <sub>2</sub>	P <sub>2</sub>	0	U <sub>2</sub> (Y <sub>2</sub> , P <sub>2</sub> , 0)

The price of the option is written as 'OP' and defined as

$$E_{\text{before}} = (p+s) \times U_1(Y_1-OP, P_1, G) + (1-p-s) \times U_2(Y_2-OP, P_2, 0)$$

$$E_{\text{after}} = p \times U_1(Y_1, P_1, G) + (1-p) \times U_2(Y_2, P_2, 0)$$

$$E_{\text{before}} = E_{\text{after}}$$

$$(p+s) \times U_1(Y_1-OP, P_1, G) + (1-p-s) \times U_2(Y_2-OP, P_2, 0)$$

$$= p \times U_1(Y_1, P_1, G) + (1-p) \times U_2(Y_2, P_2, 0)$$

The consumer's surplus (CS) of the good or service is measured in a compensated form such as following

$$U_2(Y_2, P_2, 0) = U_1(Y_1-CS, P_1, G)$$

Thus, the option value ('OV') is defined as

$$OV = OP - s \times CS$$

It is widely known that the sign of the option value become both positive and negative according to the marginal utility of income.

In the above option value model, the option price and the option value are given by a consumer's utility function. If we modify this model into using the cost functions instead of the utility function, we will give a definition of the option value of the band of frequency that comes from the future restriction of the spectrum usage.

**[Table 3] Definition of the Option Value of the Shared Spectrum**

The shared spectrum will be used	Possibility <u>Before</u> purchase of the option	Possibility <u>After</u> purchase of the option	Profit	Unit price	Quantity of output	Cost function
WITHOUT restriction	$p$	$p+s$	$\pi_1$	$r_1$	$y_1$	$C_1(y_1)$
UNDER fierce restriction	$1-p$	$1-p-s$	$\pi_2$	$r_2$	$y_2$	$C_2(y_2)$

In my presentation in the ITS Europe 2015, I will show the clear definition and the sign of option value of the shared spectrum, and also give some implication in the value of shared spectrum in comparison with the exclusively assigned spectrum.

**Reference**

A.M. Freeman III (1984): "The Sign and Size of Option," *Land Economics* 60; pp.1-13.  
A.M. Freeman III (1986): "Uncertainty and Option Value in Environmental Policy," in E. Ministry of Internal affairs and Communications (2014): document for a public hearing on the 23<sup>rd</sup> January 2014. [http://www.soumu.go.jp/main\\_content/000270523.pdf](http://www.soumu.go.jp/main_content/000270523.pdf)  
G. Pogorel and E. Bohlin (2014) 'Valuation and Pricing of Licensed Shared Access: Next Generation Pricing for Next Generation Spectrum Access'  
B.A. Weisbrod (1964), "Collective-Consumption Services of Individual-Consumption Goods," *Quarterly Journal of Economics* 78; pp.471-477.  
K. Yuguchi (2013) "Theoretical Analysis of Mobile Operators' Spectrum Strategies," *Communications & Strategies*, Volume 1, Issue 90, pp.63-76.