

Hübler, Michael

Working Paper

A trade network theory

Hannover Economic Papers (HEP), No. 553

Provided in Cooperation with:

School of Economics and Management, University of Hannover

Suggested Citation: Hübler, Michael (2015) : A trade network theory, Hannover Economic Papers (HEP), No. 553, Leibniz Universität Hannover, Wirtschaftswissenschaftliche Fakultät, Hannover

This Version is available at:

<https://hdl.handle.net/10419/117715>

Standard-Nutzungsbedingungen:

Die Dokumente auf EconStor dürfen zu eigenen wissenschaftlichen Zwecken und zum Privatgebrauch gespeichert und kopiert werden.

Sie dürfen die Dokumente nicht für öffentliche oder kommerzielle Zwecke vervielfältigen, öffentlich ausstellen, öffentlich zugänglich machen, vertreiben oder anderweitig nutzen.

Sofern die Verfasser die Dokumente unter Open-Content-Lizenzen (insbesondere CC-Lizenzen) zur Verfügung gestellt haben sollten, gelten abweichend von diesen Nutzungsbedingungen die in der dort genannten Lizenz gewährten Nutzungsrechte.

Terms of use:

Documents in EconStor may be saved and copied for your personal and scholarly purposes.

You are not to copy documents for public or commercial purposes, to exhibit the documents publicly, to make them publicly available on the internet, or to distribute or otherwise use the documents in public.

If the documents have been made available under an Open Content Licence (especially Creative Commons Licences), you may exercise further usage rights as specified in the indicated licence.

A Trade Network Theory

Michael Hübler[†]

Hannover Economic Papers (HEP) No. 553

ISSN 0949-9962

February 2015

Abstract

This paper introduces a new trade model type. It combines the gravity model, well-known in international economics, with network theory. With this approach, complicated trade networks can be algebraically solved in form of systems of linear (differential) equations. Business cycles and productivity shocks can be represented via complex numbers or the Laplace transformation. With the help of this model, new mechanisms of international trade are identified. Four theoretical examples with numerical applications are presented. First, it is demonstrated how an increase in trade from Asia to North America affects the world economy. Second, an intuitive rule for finding the welfare-optimal tariff is derived. Third, three possibilities for vanishing trade effects (fluctuations) are explained: trade diversion, the “river-island effect”, and overlapping business cycles. Fourth, it is shown how adjustment costs delay the propagation of shocks or business cycles.

JEL Classifications: F11; F42; F44

Keywords: international trade; gravity model; network theory; business cycles; propagation of shocks

*The responsibility for the contents of this discussion paper rests with the author. Since discussion papers are preliminary, it may be useful to contact the author about results or caveats. – I thank Simon Koesler at the Centre for European Economic Research (ZEW), Mannheim, Germany, for aggregating and providing the data. I thank Gabriele Michalke and Robin Kaiser for very helpful comments.

[†]Corresponding author, email: huebler@iuw.uni-hannover.de, tel: +49-511-762-19569, fax: +49-511-762-2667, Leibniz Universität Hannover, faculty of economics, Königsworther Platz 1, 30167 Hannover, Germany.

1 Introduction

This paper introduces a new way of thinking about international trade. It focuses on the real-economic connections between trading partners in a global trade network. Surprisingly, a trade network theory does not exist. To develop such a theory, it draws upon the well-known and empirically valid gravity model which states that trade flows increase in the GDPs¹ of trading partners and decrease in the distance between them. The difference to the existing gravity model is that trade is not only modeled between two trading partners but between a number of trading partners within a trade network. Another difference is that dynamic changes in trade can be modeled. Although the solution of such a network might look complicated at first glance, it can be obtained with the help of techniques that are well-known in electrical engineering.

A better understanding of economic connectivity within a trade network is crucial in the context of two recent phenomena. First, more research is necessary to better understand how an economic shock (e.g. an economic-crisis-related GDP drop² or a business-cycle-driven periodical GDP change) propagates through the global economic network and affects other economies. Second, more research is necessary to better understand how regional trade policy (e.g. a free-trade agreement such as a trans-Pacific or trans-Atlantic treaty) affects the global economic network and hence other economies.³

Against this background, Section 3 introduces the first model of this kind that explains how the static or dynamic performance of a large open economy propagates within a global trade network. Whereas most algebraic trade models are restricted to two trading economies (cf. Markusen et al. 1995), the following model can be algebraically solved for multiple economies without imposing a symmetry-assumption on the economies (unlike Melitz 2003). Notably, there is no necessity to make a restrictive assumption on the substitutability of traded goods (such as Armington 1969), either. The model follows the literature on macroeconomic multi-region trade modeling (Metzler 1950; Eaton and Kor-

¹Gross domestic products.

²This paper solely deals with real-economic effects. In terms of real-economic effects, the economic crisis from 2007 onwards showed that international financial and real-economic connectivity go hand in hand and that trade reacts sensitively to GDP shocks.

³This paper represents any barriers to trade, including non-tariff barriers, in form of a trade resistance. A reduction of the static trade resistance can, for example, mimic a free trade agreement. Besides this static trade resistance, it introduces a dynamic trade resistance, which takes the adjustment of the trade infrastructure and other adjustment costs into account.

tum 2002; Markusen and Venables 2007; Costinot 2009). This literature usually assumes n economies without spatial anchorage. The following paper extends on this literature by allowing for any explicit spatial collocation of the network.

From a dynamic perspective it is also the first model that implements business cycles in form of periodical sine-shaped developments of GDPs and trade flows in a trade network. In this respect, it follows the view that stronger trade relations between economies result in stronger business cycle co-movements (cf. Backus et al. 1994; Frankel and Rose 1998; Kose and Yi 2006) and that fluctuations of international prices affect business cycles of (developing) economies (Kose 2002). As a novelty in the literature, the paper analyzes the propagation of temporary and periodical shocks, affecting international prices and trade through the network, in an algebraic way. At this juncture the paper follows the observation that terms-of-trade shocks can create real-economic effects in other economies (Broda and Tille 2003). In this context, the paper introduces adjustment costs which create sluggish adjustments of international trade to GDP shocks or fluctuations. Feenstra and Lewis (1994) state that adjustment costs and their consequences for welfare effects have for a long time been neglected. Meanwhile, the literature has shown how adjustment costs dampen the adjustment of production and trade patterns and how adjustment assistance can be granted in a beneficial way (cf. Gagnon 1989; Feenstra 1994; Furusawa and Lai 1999). In this literature, adjustment costs are usually created by production factors, in particular labor, that are imperfectly mobile between sectors. It is the contribution of the following paper to study adjustment costs within a dynamic global trade network. Section 2 explains further how the paper is embedded in the literature.

A fourfold model application illustrates the usefulness of the approach. To this end, Section 4 calibrates the model to novel data on global trade flows in the year 2011. Different to standard trade models, the model calibration takes any trade barriers, including non-tariff barriers, into account. Nowadays tariffs are in many cases low, while non-tariff barriers persist. This is, for example, reflected in the debate about a trans-Atlantic free trade agreement.

As a first application, Section 5 illustrates how an increase in trans-Pacific trade affects global trade flows from a comparative static perspective.

Second, it is a standard exercise in trade theory to derive the strategic tariff which is

welfare-optimal from the viewpoint of a large open economy with the ability to influence prices on international markets. Section 6 carries out this exercise and derives an intuitive rule for the choice of the optimal tariff: The trade resistance (total trade costs determined by the travel time between trading partners, taking into account policy measures and any trade barriers) created by the home economy must equal the trade resistance of the remaining trade network from the viewpoint of the home economy.

Third, Section 7 addresses a question that has only rudimentarily been answered by trade theory so far: For what reasons can trade (fluctuations) ebb away or even cease? So far trade theory provides trade diversion as a straightforward answer. If there are two trade channels and the trade resistance strongly decreases in one channel, the bulk of the trade flow will go through this channel. Trade in the other channel will decrease because it creates avoidable costs. The following paper replicates this trade diversion effect in an illustrative way in a trade network. It then extends the current scope of knowledge by introducing two further possible explanations for vanishing trade. One explanation can be illustrated with the help of an island located in a river. The water flows on both sides of the island, while the water is calm behind the island as long as the strength of the water flows on both sides is balanced (following a specific condition). As a further explanation, one can imagine two sine-shaped business cycles that are exactly countercyclical, i.e. the maximum output of one economy coincides with the minimum output of another economy.⁴ If the business cycles additionally match regarding their magnitudes⁵, the trade fluctuations driven by business cycles will cancel out when they overlap in the network.⁶

Fourth, Section 8 introduces a novel approach to the dynamic analysis of temporary or periodical real-economic shocks that propagate in the global network. For this purpose, it adds delay elements to the network that take into account that economic effects do not propagate immediately (i.e. with infinite speed) but in a sluggish way. This sluggishness

⁴In a complicated network, the business cycles of the economies under consideration are not required to be exactly countercyclical, but the phase of their co-movement must accord with the phase shift, i.e. the angular adjustment or the time delay, generated by the network.

⁵In a complicated network, the magnitudes are not required to be exactly equal but to accord with a specific ratio which is determined by the network.

⁶In the case of trade fluctuations around zero, i.e. exports alternating with imports, trade will completely cease. In the case of trade fluctuations around a constant positive value (the expected case), the fluctuations will cancel out, while the trade flow will be positive and constant at the sum of the time-invariant components of the business cycles.

is created by capacity restrictions and related adjustment costs. This section then applies common mathematical transformation techniques in order to analyze the propagation behavior. Section 9 concludes.

2 Foundation in the literature

The new model type introduced in this paper builds upon standard trade theory. First and foremost, it integrates the well-known and empirically robust gravity model (cf. Krugman et al. 2014, chapter 2) into a trade network. This implies that the GDPs of trading partners augment the trade flow between them, whereas a larger distance between them reduces it. GDP measures the size or the weight of an economy and hence its power to influence prices and quantities on international markets. Following the Ricardian view, the potential gains from trade are determined by comparative advantages of the trading partners (not explicitly modeled). Putting both mechanisms together, we end up with a formulation in which larger economies with more pronounced comparative advantages have higher potentials to generate gains from trade.⁷ The gains from trade enter the model in form of a marginal benefit which can be expressed as a price differential. The price differential is measured between the situations without and with trade and reflects the strength of economic incentives for trade. This price differential is similar to but not equal to the terms-of-trade. The trade volume unambiguously increases in this price differential in the model (cf. Laursen and Metzler 1950, Harberger 1950 and Obstfeld 1982 for the controversy about the direction in which a currency appreciation or a terms-of-trade improvement affect the current account).

In summary, the model builds upon standard trade theory (cf. Markusen et al. 1995; Krugman et al. 2014) and combines it with standard tools from the network theory tool box which is utilized in electrical engineering (e.g. Clausert and Wiesemann 1993a). The tool box includes various methods for the algebraic and numerical analysis of static and dynamic networks. It is the main contribution of this paper to transfer these methods from the domain of network theory to the domain of economics.

⁷Asymmetric trading partners can exploit their different comparative advantages, whereas quasi symmetric partners have little scope for that.

3 The principals

This section outlines the nine principals that govern the model framework. The framework is based on the first three principals and equations that are derived from standard trade theory.

(1) Following neoclassical (Ricardian) theory, international trade⁸ is in this model driven by comparative advantages. The exploitation of comparative advantages creates a *price differential* of traded goods between the situations without trade and with trade: If economic agents recognize the potential for price reductions via trade, they will start trading in order to exploit this potential – until the marginal price reduction (or the per unit benefit) equals the marginal cost of trading (or the per unit cost). A price differential can be interpreted as an economic force that creates tension or pressure in the sense of an incentive to engage in trade. While this paper does not look deeper into the fundamental determinants of price differentials, it follows the Ricardian view that comparative advantages are reflected by opportunity costs of producing traded goods (cf. Costinot 2009 for a recent generalization of the Ricardian view). Although not explicitly modeled, technical progress in the export sector or an increased endowment of a production factor intensively used in the export sector (referring to the Heckscher-Ohlin theory) unambiguously improve the comparative advantage of an economy and raise the price differential that trade generates.

This model generalizes the *gravity model* and transfers it to trade networks. Trade increases in the GDPs of trade partners but decreases in the distance between them. The view of the gravity model is generalized by taking not only distance into account, but any trade barriers. These barriers may include natural impediments like landlockedness or remoteness as well as political impediments like tariffs or quotas and non-tariff barriers like safety requirements of goods.

Based on these considerations, we formulate the price differential P between a counterfactual situation, indicated by t , compared to a benchmark situation, indicated by 0, related to the GDPs of two trading partners f and g . In the subsequent steps, we will see that the trade volume is proportional to this price differential. Hence, the following equa-

⁸Trade is not restricted in this context; it may contain trade in goods and services as well.

tions together represent the well-known gravity model. The gravity model is formulated in a slightly more complex way than usual so that interdependencies within a network can be represented.

$$P_{fg} = P_{fg,t} - P_{fg,0} = \mu \cdot Y_f \cdot Y_g \quad (1)$$

μ is a factor that converts units and captures determinants of the price differential which the model does not formulate explicitly (for further details about the choice of units see the Section 4). P_{fg} , $P_{fg,t}$ and $P_{fg,0}$ are (directional) scalars. Before the analysis we must fix, between which points and in which direction they are measured, e.g. P_{fg} from f to g . Y signifies GDP. f and g are large open economies, this means, their exports and imports have a significant impact on prices and quantities on international goods markets. As a consequence of the above formulation, the impact of a price differential on international trade flows is the stronger the larger the economies expressed by their GDPs are. In other words, the larger an economy is the more it trades. The role of GDP can also be interpreted with respect to market power. A larger open economy has more power on international markets and can therefore induce a larger change in international prices than a small economy. These aspects are well-known in the theory of international trade.

Let us elaborate these aspects in more detail. A price differential as defined above can be viewed as a driver of international trade in this model. But why does a price differential P initially occur? In other words, what is the underlying driver of trade? The equation above answers this question. The equation follows the gravity model and focuses on GDP, denoted by Y , as a determinant of trade flows. Thus, a relative change in GDP between the counterfactual and the benchmark situation, denoted by $\Delta Y = (Y_t - Y_0)/Y_0$, will induce trade. Using this notation, let us write the factor $\mu(t, 0) = \mu(\Delta Y_f, \Delta Y_g, \varepsilon) > 0$, $\partial\mu/\partial(\Delta Y_f) > 0$, $\partial\mu/\partial(\Delta Y_g) > 0$ as a positive increasing function of the change in the GDPs of economies f and g as well as of other determinants, ε (not further specified in the model, for example, fluctuations in exchange rates). As a consequence, economic growth that expands the GDP of at least one trading partner will also expand the trade flow between them.⁹ Economic growth of 5 percent in both

⁹At this stage, our view is comparative static. The dynamic perspective is left for later sections.

economies, for example, would translate into $\mu = 1.05 \cdot 1.05 = 1.1025$. This is consistent with the empirical observation that international trade changes more strongly than the GDP of a single country. The reason is that the change in international trade is determined by the combination and interaction of GDP changes of various economies engaged in international trade, as suggested by the gravity model.¹⁰

(2) We define the *trade resistance* R , a scalar, that exists between the economies f and g as:

$$R_{fg} = \eta \cdot (D_{fg} + B_{fg}) \quad (2)$$

η is a factor that converts units and captures determinants of the trade resistance which the model does not formulate explicitly. D_{fg} denotes the distance between f and g which can be expressed as the travel distance or more accurately as the travel time. The travel time has the advantage of taking natural impediments into account. B_{fg} represents any tariff or non-tariff trade barriers. In order to add up D_{fg} and B_{fg} and their subcomponents, all trade impediments must be expressed in normalized value terms referring to the costs that they create (based on the same currency unit).¹¹

η can be written as a function $\eta(t, 0)$ that captures changes in the trade resistance between the counterfactual and the benchmark situation. A ten percent reduction in the trade resistance, for example, translates into $\mu = 0.9$.

(3) Based on the gravity model relations described above, the resulting *trade flow* from f to g can be expressed as the (directional) scalar:

$$T_{fg} = \frac{P_{fg}}{R_{fg}} \quad (3)$$

Directional means we must clarify between which points and in which direction the trade flow occurs, in this case from f to g , as a reference direction. On the one hand, this

¹⁰We assume that an expansion of the economies by five percent translates into a new GDP of $1.05 \cdot Y_0$ for each economy. Following the multiplicative definition of the gravity model, we thus obtain $1.05 \cdot Y_{f,0} \cdot 1.05 \cdot Y_{g,0}$ for the overall impact. Moving the term $1.05 \cdot 1.05$ into μ yields the factor 1.1025. In reality, trade often reacts more than proportionately to changes in GDP. This will be taken into account in the following by introducing the trade resistance as an additional factor.

¹¹Policy measures like import tariffs may vary depending on the importing economy. Nevertheless, against the backdrop of ongoing trade liberalisation and free trade agreements, it appears possible and convenient, yet not necessary, to assume that $R_{fg} = R_{gf}$ holds.

equation replicates the gravity model in the sense that the trade flow increases in the product of the trading partners' GDPs (included in P) and decreases in the distance between the trading partners (included in R). On the other hand, the equation replicates Ohm's Law, which is fundamental in physics (electrical engineering).¹² The definition of P relative to a benchmark situation indicated by 0 in Equation 1 has the following important implication. $P_{ef,0}$ signifies the price in the benchmark situation. $P_{ef,0}$ corresponds to a certain benchmark trade flow $T_{fg,0}$. If now $P_{fg,t} = P_{fg,0}$, i.e. there is no deviation of the price, there will be no resulting *additional* trade flow T_{fg} . Notwithstanding, the benchmark trade flow $T_{fg,0}$ persists. Thus, our analysis focuses on changes in trade compared to a benchmark situation, leaving the benchmark situation untouched. This appears to be reasonable and useful with respect to the counterfactual analysis of policies and shocks that cause deviations from a benchmark situation.

Rewriting 3 as $P_{gf} = T_{gf} \cdot R_{gf}$ yields another interpretation of the equation. It is also possible to determine the trade flow exogenously, e.g. $T_{gf} = \underline{T}$, while the price differential reacts endogenously according to $P_{gf} = T_{gf} \cdot R_{gf}$. Then the price change or cost induced by trade increases in the trade volume and in the trade resistance. Intuitively, trading larger volumes results in larger costs, and trading across larger distances and overcoming larger trade barriers raises costs as well. Since $P_{fg} = \mu \cdot Y_f \cdot Y_g$ according to 1, the economies' GDPs then react endogenously to changes in trade flows.¹³

Figure 1

Three intuitive definitions with three Equations 1 to 3 have clamped the model framework. Figure 1 depicts a network governed by these equations which is kept as simple as possible. In order to close the model and to solve complicated networks algebraically, we additionally require six straightforward rules.

(4) Each of the two knots, f and g , in Figure 1 represents an economy. In each knot it must hold that the sum of trade inflows equals the sum of trade outflows. Phrased

¹²The trade flow refers to electric current, the price differential refers to a differential in electrical potential, or in other words voltage, and the trade resistance refers to electric resistance in an electric network.

¹³Following the empirically robust gravity model, the product of GDPs enters the model. To what extent e 's and f 's GDP reacts is left open.

differently, the sum of all trade inflows or alternatively the sum of all outflows must equal zero. This rule implies that there is no loss or augmentation of trade volumes within the network (unless a trade flow is subtracted or added explicitly). Importantly, this rule does not imply that the *same* goods in a physical sense are traded through different connections in the network. On the contrary, each economy exports different goods depending on its comparative advantage. Iceberg costs in the sense that part of the traded volume melts away during transportation are not modeled. This view follows the concept of a closed system in general equilibrium, in which nothing can be added or subtracted in terms of normalized values.¹⁴ Furthermore this rule implies that the *balanced trade budget condition holds* for each economy. This rules out the possibility to create international debts or surpluses. Formally it must hold in each knot f in the network:

$$\sum_j T_{jf} = 0 \quad (4)$$

This means, all inflows from other knots j into knot f sum up to zero. This formulation requires a clear directional definition of each trade flow in the network. The modeler is free to choose either direction of the trade flow a priori. Once it has been chosen, it must be kept throughout the analysis. The direction of trade then determines the sign (positive or negative) of the resulting trade flow. In the basic network in Figure 1, it simply follows in terms of normalized values $T_{fg} = T_{gf}$.¹⁵ The specialization patterns of the trading economies are not visible in the figure because the scope of the network is restricted to one aggregate trade flow in each connection. Nonetheless, the physical composition of T_{fg} in general differs from that of T_{gf} as discussed before.

The ideal rule in Equation 4 does, however, not in general hold in reality. Each year, many economies run substantial trade surpluses or deficits. Therefore, in order to calibrate the model to data, one can assume that all outflows add up to a constant value C :

$$\sum_j T_{fj} = C. \quad (5)$$

¹⁴Traded goods are measured in normalized values referring to a specific currency unit so that different goods can be added up.

¹⁵If the direction of the arrow for T_{gf} is reversed in Figure 1, this will result in $T_{fg} = -T_{gf}$.

This constant value can then be calibrated to the benchmark (year) current account surplus or deficit. Notwithstanding, we normally study deviations of trade flows between a counterfactual and a benchmark situation. Thus, independent of the current account in the benchmark situation, it is reasonable to assume that Equation 4 holds with respect to these deviations.

(5) In the network in Figure 1 the trade flow $T_{fg} = T_{gf}$ is affected by the trade resistance $R_{fg} = R_{gf}$ twice, on the way from f to g and on its way back. Thus, it is intuitive and helpful to *add up the trade resistances located in series* in the connection under consideration, in this case $R = R_{fg} + R_{gf}$. For a given \underline{P} , we find $T_{fg} = \underline{P}/(R_{fg} + R_{gf})$. If the *trade resistances are located in parallel*, according to network theory (e.g. Clausert and Wiesemann 1993a) we need to add up their reciprocals (technically speaking the trade conductances) in order to simplify the network, e.g. $1/R = 1/R_{fg} + 1/R_{gf}$. The relations for the total resistance derived from serial, *ser*, or parallel, *par*, settings of trade resistances j generalize to:

$$R_{ser} = \sum_j R_{serj} \quad (6)$$

$$\frac{1}{R_{par}} = \sum_j \frac{1}{R_{parj}} \quad (7)$$

Parallel trade flows are relevant for modeling each direction of bilateral trade separately, e.g. trade from China to America and vice versa. We abstain from a more detailed treatment of the parallel setting at this stage and point to the main consequences of the two relations. On the one hand, the total trade resistance increases when a trade channel is extended in a serial way. Intuitively, trade costs increase when the trade distance is extended. On the other hand, the total trade resistance decreases when another trade channel (subject to trade costs) is added. Intuitively, the additional channel spreads a given trade volume to more vessels with the result that the initial vessels are less occupied or demanded. This reduces trade costs.

(6) In equilibrium marginal benefits of trade must equal marginal costs within all possible closed circuits in the network.¹⁶ If the marginal benefits were higher than the

¹⁶Loops with intersections are not allowed.

costs, the total gains of trade could be increased by trading a larger volume. If the marginal benefits were lower than the costs, the total gains of trade could be increased by trading a smaller volume. In equilibrium, there is no further incentive to trade more or less. This condition can also be interpreted from another perspective. A unique model solution requires that a *no arbitrage condition* holds within all possible closed circuits in the network. The condition guarantees that economic agents involved in trade do not become richer or poorer by simply transporting goods in circuits. (Note that this condition goes beyond the principal of no loss in trade volumes introduced above.) The no arbitrage condition guarantees that there is neither a gain nor a loss when trading goods in a circuit. Thus, in equilibrium agents are indifferent between trading and not trading in a circuit. Formally, it must hold for the price differentials k in each closed circuit within the network that:

$$\sum_k P_k = 0 \tag{8}$$

This means, the sum of all price differentials in a closed circuit, counted in one specific direction on the way through the circuit, equals zero. One can also interpret the above equation as the *Law of One Price* (for a specific traded good) or the *Purchasing Power Parity* condition (for various traded goods) in the presence of trade costs. Like in the case of trade flows, the above equation requires a fixed definition of the direction of each price differential. When moving clock-wise through the single circuit that exists in Figure 1, we obtain $\underline{P} - P_{gf} - P_{fg} = 0$. The latter two terms have negative signs because their arrows point against the clock-wise direction of the movement.¹⁷ This expression is equivalent to $\underline{P} = P_{fg} + P_{gf}$. This formulation illustrates that the exogenous driver or source, \underline{P} , creates an exogenous price differential on international markets which represents marginal gains from trade, whereas the total trade resistance $R_{fg} + R_{gf}$ creates an endogenous price differential which represents marginal costs of trade. Marginal gains and costs are balanced in equilibrium, i.e. the sum of the induced effects exactly matches the magnitude of the driver.

(7) The following rules are well-known in physics, particularly in electric network

¹⁷If their arrows are drawn in the opposite direction, they will enter the equation with opposite signs.

analysis (cf. Clausert and Wiesemann 1993a, pp. 36–38). They build upon the rules for adding up trade resistances in serial or parallel settings expressed by Equations 6 and 7:

$$P_{ser1} = \frac{R_{ser1}}{R_{ser1} + R_{ser2}} \cdot P \quad (9)$$

$$T_{par1} = \frac{R_{par2}}{R_{par1} + R_{par2}} \cdot T \quad (10)$$

In a serial setting, higher trade resistances create higher trade costs, expressed as larger induced price differentials P_{ser1} . Hence, the total price differential P disperses in proportion to the trade resistance R .¹⁸ Intuitively, in a parallel setting, international trade T_{par1} is incentivised by lower trade costs. Hence, the total trade flow T furcates in proportion to the inverse trade resistance $1/R$ (the trade conductance) or, phrased differently, in proportion to the *opposite* trade resistance, i.e. the trade resistance of the other connection.¹⁹

(8) The basic network illustrated by Figure 1 contains only one driver, \underline{P} . Complicated networks can contain a number of drivers. Following the *superposition* principle, well-known in network theory, different drivers and their impacts in the network act independently. Hence they can be treated and calculated separately in the first step and added up to obtain the overall effect in the second step. In a trade network, this principle applies to price differentials as well as to trade flows. It implies that each driver of price differentials or trade flows is independent from the other drivers. The assumption of independent drivers and superposition of their effects will allow us to solve the model in form of a linear equation system. Dependencies across drivers would result in a highly non-linear and hardly solvable system. But is independence a reasonable assumption from an economic perspective? It appears to be reasonable as long as we can distinguish between a few drivers of trade effects, usually one or two large open economies, and the remaining economies in which the trade effects occur. In the remaining economies all economic interdependencies are endogenously reflected by the model. The introduction of an increasing number of exogenous drivers in a network reduces the endogeneity of economic effects step by step and makes the model less flexible and responsive. Furthermore, it appears to be unrealistic to treat small open economies such as the Cayman Islands, as exogenous

¹⁸Known as the voltage divider rule in physics.

¹⁹Known as the current divider rule in physics.

drivers of a global trade network. In conclusion, the modeler needs a good economic sense for what can be deemed exogenous. In general, the number of exogenous drivers should be kept as small as possible. This implies that the model is especially useful for analyzing the trade-related global effects of a shock created by one or two large open economies.²⁰

(9) Finally, for policy assessments we need to calculate welfare effects. To this end, we define a welfare improvement for an economy in the network as a joint positive effect of a price differential multiplied by a change in the economy’s trade volume:

$$W_e = \sum_l P_{el} \cdot T_{el} \quad (11)$$

While P denotes the marginal or per unit benefit of trading, T denotes the number of units that are traded in normalized value form. Thus, P times T yields the total benefit of trading. Since P and T are related via R according to Equation 3, the welfare change W is measured with regard to each trade resistance l adjacent to the economy (represented by a knot). This closes the introduction of the model principals.

4 A calibrated global network

Figure 2 depicts a global trade network as an example. It consists of the economies (knots) European Union 27, symbolized by e (EUR) in the center, North America, n (NAM), Asia, a (ASI), and the rest of the world, denoted by w (ROW) and positioned as Africa.

The data for trade and GDP are taken from WIOD (World Input-Output Data, Timmer 2012; Dietzenbacher et al. 2013) for the year 2011. Bidirectional trade flows are aggregated in form of net trade flows, T , between the economies.²¹ GDPs, Y , and current account surpluses, C , are reported as well. Y , T and C are measured in trillion 2011-US-\$. The directions of trade flows and price differentials (indicated by arrows) are chosen such that all numerical values are positive, measured in the direction of the arrows. μ and η in Equations 1 and 2 are set to one. μ has the dimension $1/(\text{2011-US-}\$)$, while P is measured in 2011-US-\$ as well. η is chosen dimensionless. The trade resistances R are dimensionless, too. Their values are computed as residuals by inserting Equations 1 and 2 into 3.

²⁰This is usually the case in policy analysis.

²¹This will be relaxed in further analyses.

The gravity model is not appropriate for net trade flows though.²² Instead, Equation 3 is applied to each directional trade flow, e.g. from North America to the European Union. The trade resistance is determined for each trade flow. The combined trade resistance (in this case NAM to EUR combined with EUR to NAM) is then obtained via Equation 7.

Figure 2

It turns out that the trade resistances between North-America, the European Union and Asia have similar magnitudes, whereas the trade resistances leading to the rest of the world have less than half this magnitude. This outcome is due to the aggregation of numerous globally distributed countries to the residual economy labeled rest of the world (ROW). As a result, distances to trading partners are relatively small and trade flows are relatively large compared to the other economies.

This global network serves as the basis for the model applications in the following sections. In each section the global network will be adjusted in order to fit to the application purpose.

5 Global effects of trans-Pacific trade

Based on the global network introduced in the previous section, this section demonstrates how a more complicated network can be solved. As an example, this section studies how increased trans-Pacific trade from Asia (ASI) to North America (NAM) affects the trade flows in the global network. Trade might increase as a consequence of technical progress and sectoral shifts in emerging Asian economies like China and India as well as in countries like Cambodia or Bangladesh that are currently still at an early stage of economic development.²³

The analysis is comparative static. The analysis is carried out at a general algebraic level as well as at the calibrated level. The analysis draws upon Figure 2.²⁴ We modify

²²Suppose two economies trade intensively with each other but run a zero trade deficit with each other. Based on the resulting net trade flow of zero, we would make the false conclusion that an infinite trade resistance exists between them.

²³These underlying aspects are not modeled explicitly.

²⁴It does in general suffice to deal with net trade flows as long as the economies endogenously react to

the network by splitting the net trade flow between Asia and North America into the two directional trade flows between these economies (see Appendix, Figure 4).²⁵ Let us now assume that the trade flow from ASI to NAM increases. \underline{T}_{an} is exogenously given and reflects this increase. The opposite trade flow from NAM to ASI will increase as well following the basic model and the argumentation outlined in section 3. Now the expansion of ASI-NAM trade, however, also affects the remaining global network, and the reaction of the global network may have repercussions on NAM-ASI trade as well. All these endogenous effects are captured by the model.

Although the model consists of only four economies, the algebraic solution is demanding because of the “bridge” structure of the network (with the EUR-ROW connection). We pursue the following solution strategy (following Clausert and Wiesemann 1993a, p. 102-105). For each trade connection including a trade resistance we apply Equation 3 that relates trade flows to price differentials via trade resistances. This yields six equations. For each economy not located in the center, i.e. NAM, ASI and ROW, we formulate Equation 4. Notably, current account surpluses C are part of the benchmark situation but do not affect deviations from it, which we study here. We obtain three equations for trade flows. Furthermore, the network encompasses three circuits, $na - ae - en$, $ne - ew - wn$ and $ea - aw - we$. To each circuit we apply Equation 8. This yields three more equations, now written in terms of price differentials. In total, we gain 12 equations as well as 12 unknowns: six trade flows T and six price differentials P in each trade connection with a trade resistance. Trade resistances R are exogenously given (see Figure 2). After substituting unknowns and rearranging terms we obtain three equations in three unknowns defined for each non-center economy:

$$\begin{aligned}
ASI : & \quad \left(\frac{1}{R_{ae}} + \frac{1}{R_{wa}} + \frac{1}{R_{na}} \right) \cdot P_{ae} - \frac{1}{R_{wa}} \cdot P_{we} - \frac{1}{R_{na}} \cdot P_{ne} = -\underline{T}_{an} \\
ROW : & \quad -\frac{1}{R_{wa}} \cdot P_{ae} + \left(\frac{1}{R_{ew}} + \frac{1}{R_{wa}} + \frac{1}{R_{wn}} \right) \cdot P_{we} - \frac{1}{R_{wn}} \cdot P_{ne} = 0 \\
NAM : & \quad -\frac{1}{R_{na}} \cdot P_{ae} - \frac{1}{R_{wn}} \cdot P_{we} + \left(\frac{1}{R_{en}} + \frac{1}{R_{wn}} + \frac{1}{R_{na}} \right) \cdot P_{ne} = \underline{T}_{an}
\end{aligned}$$

changes in trade elsewhere. The bilateral trade between two economies is not relevant with respect to its interaction with the remaining network as long as the two economies run a zero current account surplus with each other. What matters with respect to interactions are changes in the current account reflected by changes in net trade flows.

²⁵We change the direction of some arrows so that the specification of the network eases the following analysis in accordance with common network methodology (cf. Clausert and Wiesemann 1993a, p. 102).

With the help of the network methodology it is also possible to write out these three equations immediately (cf. Clausert and Wiesemann 1993a, p. 103). By solving this linear equation system and re-substituting terms we find a unique algebraic solution for each of the 12 unknowns. We abstain from spelling out these terms, and turn back to the numerical calibration depicted by Figure 2. Let us assume that the benchmark year (2011) trade flow from ASI to NAM labeled as \underline{T}_{an} with a volume of 810.0 billion 2011-US-\$ goes up by ten percent, i.e. by 81.0 billion 2011-US-\$. Inserting this number together with the given values of trade resistances into the algebraic solution yields the new equilibrium values.

Accordingly, the NAM-ASI trade flow, T_{na} , opposite to the exogenously added trade flow \underline{T}_{an} , increases by only 17.4 (the unit is here and in the following billion 2011-US-\$). This means that the bulk of the trade expansion goes through the global economy. This result fits to the empirical fact that the United States import more from China than China imports from the United States. Although, NAM cannot run an additional overall trade deficit in our counterfactual experiment, it can compensate its additional imports from ASI by exports to other regions. ASI in turn imports more from the other regions so that no additional trade deficit or surplus occur in any model region.

Increased ASI-NAM trade induces the following changes in trade flows among the other regions. T_{ne} increases by about 27.9, and T_{ea} increases by 21.3. T_{nw} increases by 34.7, and T_{wa} increases by 41.3. T_{ew} increases by 6.6. Thus, a large part of the exogenously added ASI-NAM trade flow does not directly go back via the NAM-ASI connection, but goes through the NAM-EUR-ASI connection and to a somewhat larger extent through the NAM-ROW-ASI connection. Though, the EUR-ROW connection is hardly affected – a phenomenon that will be studied in more detail in Section 7.2. Such subtle trade effects are hardly visible in conventional (computable) general equilibrium models.

The exercise shows that, given the model assumptions, a relatively small intervention in trade from one economy to another one can generate significant repercussions on trade throughout the world economy. The directions and the magnitudes of the resulting changes in the network can hardly be predicted ex ante. For this purpose, the new model intends to provide a helpful new analytical tool. The current aggregation is, however, aggregate and can easily be extended, for example, to the country-level. Given today’s computational

capability, the resulting linear equation system can be numerically solved. Section 7.1 will resume this analysis by assuming that a trans-Pacific free trade agreement drastically reduces trade costs.

6 Optimal tariffs

The derivation of the welfare-optimal tariff chosen by a large open economy is a standard policy analysis in trade theory. Hence, a new trade theory should be able to replicate this standard analysis. This section fulfills this requirement and goes one step further. It derives an optimality condition for the tariff set by a large open economy which differs from existing optimality conditions in terms of simplicity, clarity and generality.

Proposition 1. *The optimal tariff with regard to welfare maximization of a large open economy adjusts the trade resistance of the economy to the trade resistance that the remaining network creates from the viewpoint of the economy.*

We build on the network shown in Figure 2 with the split-up of trade between Asia and North America (ASI-NAM) in Figure 4. We simplify the network by assuming that $T_{ew} = 0$ ($R_{ew} \rightarrow \infty$). This means, the connection between EUR and ROW is removed in the figure. We look once again at the ASI-NAM trade connection and ask the question: How large is the trade resistance of the entire remaining network when looking into it from points n and a ? From this viewpoint we can see two parallel connections, $n - a$ via e and $n - a$ via w . We use equation 7 to determine the substitute for this parallel setting. Within each connection, there are two serial trade resistances. We use equation 6 to determine the substitute for each serial setting. We end up with the overall substitute resistance:

$$R_s = 1 / \left(\frac{1}{R_{en} + R_{ae}} + \frac{1}{R_{wn} + R_{wa}} \right) \quad (12)$$

For the calibration shown in Figure 2 we find $R_s = 188.7$. The change in trade is again driven by \underline{T}_{an} , while we search for the optimal resistance R_{na} that maximizes the welfare gain from trade for the trading partners ASI and NAM. (The distribution of the welfare gain to the trading partners is not explicit. One can assume that it occurs in proportion

to their GDP.) To achieve this, we maximize welfare defined by Equation 11. In a parallel setting, the magnitude of trade flows increases in proportion to the opposite trade resistance as stated by Equation 10. In this case it can be expressed as:

$$T_{na} = \frac{R_s}{R_s + R_{na}} \cdot \underline{T}_{an} \quad (13)$$

Inserting this equation together with 3 into 11 yields the required welfare effect of trade:

$$W_{na} = P_{na} \cdot T_{na} = R_{na} \cdot (T_{na})^2 = R_{na} \cdot \left(\frac{R_s}{R_s + R_{na}} \cdot \underline{T}_{an} \right)^2 \quad (14)$$

$\frac{\partial W_{na}}{\partial R_{na}} = 0$ leads to $R_s^2 - R_{na}^2 = 0 \Leftrightarrow (R_s + R_{na}) \cdot (R_s - R_{na}) = 0$ and thus for the optimal tariff:

$$R_{na,opt} = R_s \quad (15)$$

with $R_s > 0$ and $R_{na} > 0$. Details of this calculation can be found in the Appendix. \square

With our model calibration we find $R_{na,opt} = 188.7$, which is less than one third of the current trade resistance, $R_{na} = 667.6$. This result suggests that there are currently impediments to trade from North America, say the United States, to Asia, say China, which are welfare inferior for both trading partners. For example, exchange rates might play a role; yet this model does not deal with the particular determinants of trade resistances.

The algebraic result has general relevance and is not specific for our network and the specific trading partners. As in standard trade theory, the optimal tariff rule reflects a trade-off between raising international prices in favor of the home economy (i.e. improving the terms-of-trade, here reflected by P_{na}) and reducing trade volumes (here T_{na}), which is harmful for the home economy. The optimal tariff $R_{na,opt}$ balances these counteracting forces.

7 Vanishing trade

This section deals with three possible reasons for vanishing trade flows. Note that we study counterfactual effects of price differentials and changes in trade flows, whereas the benchmark composition of trade in the network is unaffected without any necessity that

benchmark trade flows vanish. The trade diversion effect in the sense that lower trade resistances induce (inefficiently) higher imports from the corresponding trading partner is well known in trade theory.²⁶ The first subsection recaps this effect within the new theory in a straight-forward way. It shows that the trade diversion effect can be so strong that trade concentrates on one trade channel and ebbs away in the other trade channel. The “river-island effect”, introduced by the second subsection, is new in economics. It refers to a situation where trade flows pass by an island on both sides without affected the space behind the island if a certain condition for the relation of the flows is fulfilled. The third subsection explains how business cycles add up based on the superposition principle. If they generate countercyclical movements of trade and their magnitudes match a specific ratio, the fluctuations will cancel out at each point of time.

7.1 Trade diversion

Proposition 2. *The reduction of the trade resistance between two economies can redirect trade flows from the remaining network to these economies so that trade ebbs away in the remaining network (trade diversion).*

As in the optimal tariff analysis, we use the simplified network based on Figure 4 with $T_{ew} = T_{we} = 0$ ($R_{ew} \rightarrow \infty$). Also like in the optimal tariff analysis, we look at the trade resistance R_{na} between North America and Asia in comparison with the given trade resistance of the remaining network R_s . Instead of searching for the optimal R_{na} let us now assume that a trans-Pacific free trade agreement allows North America (NAM) and Asia (ASI) to substantially reduce trade costs. In the theoretical boarder case we assume $R_{na} \rightarrow 0$. According to Equation 10, we obtain for the trade flow from NAM to ASI: $T_{na} = \frac{R_s}{R_s + R_{na}} \cdot \underline{T}_{an}$ and hence: $\lim_{R_{na} \rightarrow 0} T_{na} = \underline{T}_{an}$. This means, the full trade flow driven by \underline{T}_{an} flows back as T_{na} and there is no additional trade created in the remaining global network compared to the benchmark situation. \square

In reality, a free-trade agreement will not drive down trade costs to zero. Hence, the effect will be less drastic. For the numerical importance of increased trans-Pacific trade, the reader may refer to Section 5, which assumes a more realistic 10 percent increase in

²⁶Trade diversion usually refers to increased imports from an exporter who is relatively inefficient in the production of his export good. This aspect is not relevant for this analysis.

trans-Pacific trade. This exercise replicates an effect which is well-known in international economics. The following subsections will introduce new effects and provide new insights.

7.2 River-island effect

Proposition 3. *Proportionately balanced trade flows surrounding the trade connection between two economies can result in vanishing trade within this connection (river-island effect).*

We apply the full global network depicted by 4 with two modifications: We collapse the two bilateral trade connections to one net trade connection as in Figure 2, and we set the price differential between ASI and NAM exogenously to \underline{P}_{an} . Consequently, trade flow T_{an} emerges endogenously. (R_{an} is left out.) Drawing upon Equation 9, we obtain $P_{ae} = \frac{R_{ae}}{R_{ae}+R_{en}} \cdot \underline{P}_{an}$ for the upper trade connection and $P_{aw} = \frac{R_{wa}}{R_{wa}+R_{wn}} \cdot \underline{P}_{an}$ for the lower trade connection. If now $\frac{R_{ae}}{R_{ae}+R_{en}} = \frac{R_{wa}}{R_{wa}+R_{wn}}$ or equivalently $\frac{R_{ae}}{R_{en}} = \frac{R_{wa}}{R_{wn}}$ then $P_{ae} = P_{aw}$ and hence $P_{we} = P_{ae} - P_{aw} = 0$ (cf. Clausert and Wiesemann 1993a, p. 40). This means, trade between the rest of the world and Europe, T_{we} , ceases because of Equation 3. \square

One might argue that Europe would still demand goods from the rest of the world, say Africa, and vice versa. This is true and taken into account by the benchmark trade volume $T_{we,0}$ which is strictly unaffected by $T_{we} = 0$.²⁷ In this sense, the result $T_{we} = 0$ creates a protective shield against changes in trade flows rather than a rigorous latch against trade in general.

Based on the trade resistance values reported in Figure 2, we can exemplarily calculate the trade resistance between Asia and Europe, R_{ae} , which ceteris paribus fulfills the condition derived above. We obtain $R_{ae} \approx 110.5$ which is almost half the current value of 216.6.²⁸ Hence, substantial reductions of trade barriers between Europe and Asia or substantial progress of transportation technologies could create a situation, in which the rest of the world, in particular Africa, would be shielded from shocks affecting international goods markets.

²⁷The value of the trade resistance R_{ew} between Europe and Africa is in this case irrelevant because there is no trade (in addition to benchmark trade).

²⁸This is not a unique solution in terms of absolute numbers. There is an arbitrary number of solutions that satisfy the derived condition.

7.3 Business cycles

Proposition 4. *Business cycles (GDP movements) of two economies can generate vanishing trade flows.*

We build on the network shown in Figure 4 with $T_{ew} = 0$ ($R_{ew} \rightarrow \infty$). In order to further simplify the network we assume $T_{an} = T_{na} = 0$ ($R_{an} \rightarrow \infty$, $R_{na} \rightarrow \infty$), too. We split trade between North America and Europe (NAM-EUR) as well as between Asia and the rest of the world (ASI-ROW) into its bidirectional components. Figure 5 illustrates the resulting trade network. The values of the additional trade resistances are for each pair of economies and each direction ($R_{en}, R_{ne}, R_{aw}, R_{wa}$) computed with the help of Equations 1 and 3.²⁹ We assume that in the trade connection NAM-EUR an exogenous price differential \underline{P}_1 exists and that in the trade connection ASI-ROW an exogenous price differential \underline{P}_2 exists. Each price differential is an exogenous driver of international trade. We want to know how large the resulting (induced) trade flow from Europe to Asia (EUR-ASI), T_{ea} , is.

In order to solve the network, we apply the superposition principle (see Section 3, principal 8), which is a standard method for dealing with overlapping fluctuations or oscillations. In the first step, we set $\underline{P}_2 = 0$. This means, in Figure 5 the circular symbol for \underline{P}_2 can be replaced by a normal connection line. Then the network contains only one driver of additional trade flows, \underline{P}_1 , and can be analyzed as before by using Equations 3 to 10. The Appendix details the linear equations that describe the network and their solution. As a result, we obtain the price differential between Asia and Europe as a linear function of the driver \underline{P}_1 :

$$\begin{aligned} P_{ea1} &= V_1 \cdot \underline{P}_1, \quad V_1 > 0 \\ T_{ea1} &= \frac{V_1 \cdot \underline{P}_1}{R_{ae}} \end{aligned} \tag{16}$$

V_1 is a constant, dimensionless trade resistance factor that is determined by the network solution. T_{ea1} is the first component of the unknown trade flow. The second component, T_{ea2} , can be found by re-introducing the exogenous price differential \underline{P}_2 and setting $\underline{P}_1 = 0$

²⁹It follows from Equation 7 that each of the two parallel bilateral trade resistances in Figure 5 has a higher value than the trade resistance that replaces them in Figure 4.

instead. The solution strategy mirrors that for T_{ea1} . Now we obtain:

$$\begin{aligned} P_{ea2} &= V_2 \cdot \underline{P}_2, \quad V_2 > 0 \\ T_{ea2} &= \frac{V_2 \cdot \underline{P}_2}{R_{ae}} \end{aligned} \quad (17)$$

V_2 is also a constant trade resistance factor. Applying the superposition principle, we add up the two components and obtain:

$$T_{ea} = T_{ea1} + T_{ea2} = \frac{V_1 \cdot \underline{P}_1 + V_2 \cdot \underline{P}_2}{R_{ae}} \quad (18)$$

Vanishing trade effects require $T_{ea} = 0$ and hence $V_1 \cdot \underline{P}_1 + V_2 \cdot \underline{P}_2 = 0$ or

$$\frac{\underline{P}_1}{\underline{P}_2} = -\frac{V_2}{V_1} \quad (19)$$

This equation expresses that from a static point of view the two price differentials that drive trade must have opposite directions and that the ratio of their magnitudes must equal the inverse ratio of the trade resistance factors.

From a dynamic point of view cyclical movements of GDP and trade flows can be described by *(co-)sine functions*³⁰, and more elegantly by *complex amplitudes* (cf. Clausert and Wiesemann 1993b, chapter 7.2).³¹ The advantage of using complex amplitudes is that all rules and methods used so far can be applied (cf. Clausert and Wiesemann 1993b, pp. 49–59). The difference is that the real numbers, which represented static, constant magnitudes, are replaced by complex numbers, which represent, sine-shaped, dynamic magnitudes. This allows us to represent the impact of sine-shaped business cycles (GDP

³⁰We write sine for simplicity, noting that sine and cosine functions can be converted into each other via 90° ($\Pi/2$) phase shifts, i.e. via angular adjustments or time delays.

³¹A complex number, \tilde{N} , consists of a real part, $\Re(\tilde{N}) = a$, and a complex part, $\Im(\tilde{N}) = b$, together $\tilde{N} = a + i b$, where $i = \sqrt{-1}$. Complex numbers can be plotted in a complex plane (Gauss plane), in which the abscissa depicts the real part, and the ordinate depicts the complex part. In this sense, the real and the complex part represent two Cartesian coordinates. A complex number can also be characterized by its (real) magnitude, \hat{N} , measured from the origin of the complex plain to the position of the number, and the angle, α , between the abscissa and the line that depicts the magnitude. This yields a representation in polar coordinates. Euler's formula allows us to rewrite a complex number as a *complex amplitude* in the form $\tilde{N} = \hat{N}e^{i\alpha} = \hat{N}(\cos \alpha + i \sin \alpha)$, where the basis e is Euler's number (whereas the index e denotes Europe elsewhere in the paper).

fluctuations) on international price differentials based on Equation 1:

$$\tilde{P}_{fg} \cdot e^{i\omega_f t} = \hat{P}_{fg} \cdot e^{i\alpha_f} \cdot e^{i\omega_f t} = \mu \cdot \tilde{Y}_f \cdot e^{i\omega_f t} \cdot Y_g = \mu \cdot \hat{Y}_f \cdot e^{i\alpha_f} \cdot e^{i\omega_f t} \cdot Y_g \quad (20)$$

The oscillations of economy f 's GDP, Y_f translate into oscillations of the international price differential, P_{fg} . \tilde{P}_{fg} represents a complex amplitude, while $e^{i\omega_f t}$ describes the sine-shape movement over time, t , with the frequency, ω_f , expressed as a radian measure. The complex amplitude is rewritten as the product of its magnitude and its phase (i.e. the starting point of the sine wave compared to the reference point $t = 0$). \hat{P}_{fg} is a real number that represents the magnitude of the business cycle (i.e. the difference between its maximum value and zero which is one for the standard sine function). The phase, α_f , of the cycle is expressed as a radian measure, too. The complex amplitude \tilde{Y}_f is constructed in the same manner as \tilde{P}_{fg} . We obtain the behavior of the price differential in the time dimension (expressed in form of real numbers) from the real part of the complex expression:

$$P_{fg}(t) = \Re(\tilde{P}_{fg} \cdot e^{i\omega_f t}) \quad (21)$$

We are now able to rephrase Equations 16 to 19 by using complex amplitudes for every price differential, P , and trade flow, T . The two price differentials that drive trade are rewritten as \tilde{P}_1 and \tilde{P}_2 . Now they describe exogenous time-variant sine shapes. Under the assumption that time-variant shocks can propagate through the network without any delay, V_1 and V_2 are computed in form of real numbers as before. – They will become complex numbers, once we model adjustment costs and delay in the next section. The next section will also relax the sine-shape assumption. – Equation 19 now reads:

$$\frac{\tilde{P}_1}{\tilde{P}_2} = -\frac{V_2}{V_1} \quad (22)$$

This condition implies for the corresponding behavior in time that $\frac{\Re(\tilde{P}_1 \cdot e^{i\omega_1 t})}{\Re(\tilde{P}_2 \cdot e^{i\omega_2 t})} = -\frac{V_2}{V_1}$ and hence $\frac{\hat{P}_1 \cdot \cos(\omega_1 t + \alpha_1)}{\hat{P}_2 \cdot \cos(\omega_2 t + \alpha_2)} = -\frac{V_2}{V_1}$. It follows for the magnitudes of the two business cycles that $\frac{\hat{P}_1}{\hat{P}_2} = \frac{V_2}{V_1}$ must hold so that the two drivers cancel out. It follows for the phases of the cycles that $\cos(\omega_1 t + \alpha_1) = \cos(\omega_2 t + \alpha_2) = 0$ so that the drivers cancel out. The solution

encompasses all situations, in which either both cycles are zero or have opposite signs and equal magnitudes. If both business cycles have the same frequencies, i.e. $\omega_1 = \omega_2$, it must hold that $\alpha_1 + \alpha_2 = \pi$ (half a business cycle).³² Hence, the two business cycles must be exactly *countercyclical*. In this case, the impact of the two business cycles on the international price differential and trade flow under scrutiny cancels out at any point of time. Notwithstanding, at specific points in time the two cycles can cancel out, too, for other differences in magnitudes (\hat{P}_1 and \hat{P}_2), frequencies (ω_1 and ω_2), and phases (α_1 and α_2) that fulfill condition 22. \square

The second part of the next section will resume this analysis.

8 Adjustment costs

The relevance of adjustment costs created by capital investments is well understood (cf. Goulder and Summers 1989). In the domain of international trade, modeling adjustment costs is less common (cf. the literature cited in the Introduction). Adjustment costs are relevant in this domain, because transportation infrastructure, such as harbors and shipping, are subject to capacity restrictions. Over- and under-capacities create costs, and the adjustment of available capacities creates costs as well. Furthermore, the literature has studied adjustment costs created by imperfectly mobile production factors (e.g. Feenstra 1994; Furusawa and Lai 1999). Once we take these costs implicitly into account, any adjustment of trade volumes will not occur immediately (with infinite speed and without any costs), but sluggishly with a delay. As we will see, the resulting adjustment process is similar to the *J-curve*³³, yet it is solely driven by real-economic effects. The duration of a typical *J-curve* adjustment process associated with a currency depreciation is between six and twelve months (cf. Krugman et al. 2014, chapter 17). Since this adjustment process is empirically often measured as the time delay between a change in relative prices and the impact on trade flows, we can suppose that time delays of about six to twelve months also apply to the following model.

³²A full business cycle of 2π may, for example, correspond to a time span of three years. When inspecting the sine functions, it is obvious that a phase difference of π , i.e. half a business cycle, results in countercyclical functions with opposite signs at any point of time (or both being zero).

³³An economy's trade balance can describe a *J-curve* after a depreciation of its currency because trade volumes are rigid in the short-term while their value adjusts immediately.

Sluggish behavior occurs in mechanical and electrical systems as well. Therefore, we can draw upon the methodological tool box used in Physics. This will enable us to model the propagation of shocks or business cycles within a trade network subject to sluggishness and time delay. This aspect is novel in trade theory.

In order to account for the propagation of shocks with finite speed, we add delay elements to the basic network introduced by Figure 1. This modification is shown by Figure 3. The delay elements represent adjustment costs based on Equation 3:

$$T_{fg} = A_{fg} \cdot \frac{dP_{fg}}{dt} \quad (23)$$

This formulation takes into account that any (exogenous) change in the price differential, P^{34} , over time, t , induces an adjustment trade flow, T^{35} , which is dampened by the dynamic trade resistance A . A describes the strength of adjustment costs. The higher A , the more sluggish is the reaction of the system.

Figure 3

The static (R) and dynamic (A) trade resistances can be added up according to Equation 6: $R := R_{fg} + R_{gf}$, $A := A_{fg} + A_{gf}$. We add up $P_A := P_{Afg} + P_{Agf}$, too. Using Equations 8 (the price differentials add up to zero in a closed loop) and 23, we can spell out the following linear first-order differential equation:

$$\underline{P} = R \cdot A \cdot \frac{dP_A}{dt} + P_A \quad (24)$$

Let us assume that a positive, temporary productivity shock occurs in $t = 0$ such that economy f 's GDP rises (directly without time delay), and as a result \underline{P} jumps from zero (no price differential compared to the benchmark situation) to \hat{P} .³⁶ We want to know how

³⁴ P itself is defined as a price differential between a counterfactual and a benchmark situation according to Equation 1. Now we let this previously constant price differential vary in time.

³⁵ T is implicitly measured as the value (e.g. US-\$) of a trade flow per time span (e.g. year). Let Δt denote this time span. Hence, a change in the price differential, ΔP will induce a stronger T when the time span of the change, Δt , becomes smaller. For infinitesimal changes ΔP per Δt , we end up with Equation 23. The equation implies that T depends on the first derivative of P with respect to t , i.e., it depends on the slope of the P function.

³⁶Note that the system stays at its terminal level forever after the adjustment process, i.e. the temporary

the trade flow T_{gf} emerges over time. The resulting differential equation can be solved for P_A with a standard approach or with the help of the Laplace transformation as detailed in the Appendix (cf. Clausert and Wiesemann 1993b, pp. 280–286). Let us assume that P_A is zero in $t = 0$. Then the adjustment of the trade flow is described by Figure 6 (a) (*positive shock*) in the Appendix and the following function:

$$T_{gf} = R \cdot \hat{P} \cdot \left(1 - e^{-\frac{t}{AR}}\right) \quad (25)$$

Due to the positive adjustment costs, the trade flow cannot immediately jump to a new value, because a jump would create infinite adjustment costs. Hence, trade adjusts to its terminal value $R \cdot \hat{P}$ in a sluggish way with time delay. In physics, the product $A \cdot R$ is called the *time constant*. The larger the time constant, i.e. the higher constant trade costs and the adjustment costs are, the more time the adjustment process will take. The existence of a causal, time-dependent relation between GDP and trade and vice versa is rather undisputed (cf. Zestos and Tao 2002). The empirical duration of the time lag between GDP and trade and vice versa is controversial, though (cf. Gagnon 1989). Observations during the economic crisis from 2007 onwards as well as recent data suggest that a fast and strong interrelation between GDP and trade exists (see for example quarterly data from OECD.StatExtracts 2014). Historical observations of the development of the American trade deficit in the 1980s, on the contrary, indicate that the interrelation might be subject to a long time horizon (cf. Gagnon 1989). Yet our analysis does not hinge upon a specific assumption on the duration of the time lag.

We have studied the dynamic behavior of trade with adjustment costs based on the simplest possible network with two trading partners. Dynamic trade resistances can, however, be added to each branch of any complex network. The resulting network can then be analyzed with the help of the Laplace transformation (as exemplarily demonstrated in the Appendix) and Equations 1 to 11.

We have assumed a positive productivity shock as a starting point. The same model and solution can be used to describe a negative shock, e.g. due to an economic crisis, that triggers a transition of the price differential P_A from a given initial value $P_{A0} = \hat{P}$

shock has a persistent effect.

to a terminal value $P_{A1} = \widehat{P}_2$ with $\widehat{P} > \widehat{P}_2 \geq 0$. The behavior described by the resulting function is also illustrated by Figure 6 (a) (*negative shock*) in the Appendix:

$$T_{gf} = R \cdot \left[\widehat{P}_2 \cdot \left(1 - e^{-\frac{t}{AR}} \right) + \widehat{P} \cdot e^{-\frac{t}{AR}} \right] \quad (26)$$

Let us now resume the analysis of business cycles of the last section. Once we allow for time delay within the network, it is not necessary that the original business cycles of two economies are exactly countercyclical so that trade can vanish. Instead, the phase difference between the two business cycles must match the time delay that the network creates so that overall a phase difference of half a period emerges.

We assume that $\underline{P} = \widehat{P}_s \cdot \sin \omega t$ describes a periodical price fluctuation driven by a business cycle (a periodical GDP fluctuation). One can insert \underline{P} in Equation 24 and solve the differential equation with conventional methods or with the help of complex numbers as introduced in the previous section and shown in the Appendix. With the latter approach the dynamic trade resistance takes the form (cf. Clausert and Wiesemann 1993b, p. 56):³⁷

$$A_{fg} = \frac{1}{i\omega A} = -\frac{i}{\omega A} \quad (27)$$

This formulation takes into account that for higher frequencies, ω , the system can hardly follow the fluctuations due to the sluggishness of the system. Hence, $\lim_{\omega \rightarrow \infty} \frac{1}{i\omega A} = 0$.³⁸ The formulation accords to Equation 23 in the sense that the first derivative of a sine-function is a cosine-function. When the sine-function is zero, its slope has its maximum of one or its minimum of minus one. This implies a phase shift, i.e. an angular adjustment or a time delay, of a quarter period or $\Pi/2$ (90°). This phase shift is represented by the multiplication of A with i in the Gauss plane.

Based on the complex-number formulation, we can rewrite Equation 24 with the com-

³⁷For rewriting the equation below, note that $i \cdot i = -1$.

³⁸Equation 27 is not well-defined for $\omega = 0$, since in this case no periodical (sine-) function exists. Hence, for static networks we must use Equations 2 and 3.

plex amplitude $\underline{\tilde{P}} = \hat{P}_s \cdot e^{i\omega t}$ as:

$$\underline{\tilde{P}} = \frac{1}{i\omega A} \cdot \tilde{T}_{gf} + R \cdot \tilde{T}_{gf} = \left(R - \frac{i}{\omega A} \right) \cdot \tilde{T}_{gf} \quad (28)$$

The Appendix details the calculation of the magnitude and phase of $\tilde{T}_{gf} = R \cdot \tilde{P}_A$ compared with $\underline{\tilde{P}}$ as a function of A , R and ω . If the network is solely determined by the static trade resistance R , while $A = 0$, there will be no phase difference between \tilde{T}_{gf} and $\underline{\tilde{P}}$ as assumed in Sections 3 to 7. If the network is solely determined by the dynamic trade resistance A (adjustment costs only), while $R = 0$, there will be a phase difference between \tilde{T}_{gf} and $\underline{\tilde{P}}$ of a quarter period, i.e. $\Pi/2$ (90°). If both, A and R , determine the network, the phase difference will be in between, as depicted by Figure 6 (b) in the Appendix.

9 Conclusion

This paper has introduced a new direction of modeling and thinking about international trade. It has focused on the real-economic connections between economies in a global network via international trade. The paper provides insights into the propagation of policy effects. It has demonstrated how trade policy, business cycles and productivity shocks affect the global network. It has confirmed that a reduction in trans-Pacific trade barriers is welfare-improving for North America and Asia. This result corroborates plans for trans-Pacific free trade agreements. The paper has shown that a moderate increase in trans-Pacific trade has significant repercussions on the world economy. Without the methodology presented in this paper, these effects are ex ante hardly predictable. Moreover, the paper has shown that halving the trade barrier between Europe and Asia could create a situation in which the rest of the world, in particular Africa, is to some extent protected from shocks affecting international goods markets.

The paper provides helpful tools of electric network theory to economists who model and analyze international trade. Since most of these tools are new in the domain of economic theory, the application examples focused on the illustration of the key mechanisms. Future policy analyses may set up more complicated trade networks with a large number of economies and possibly several sectors. Given today's computational power, complicated static (based on linear equation systems) as well as dynamic (based on linear

first-order differential equation systems) can be solved within reasonable time. Against this background, this paper opens a fruitful avenue for analyzing economic shocks and policies in trade networks.

10 References

- ARMINGTON, P. (1969). A theory of demand for products distinguished by place of production. *IMF Staff Papers*, Washington, DC, USA, 16, 159–178.
- BACKUS, D.K., P.J. KEHOE AND F.E. KYDLAND (1994). Dynamics of the trade balance and the terms of trade: The J-Curve? *The American Economic Review* 84(1), 84–103.
- BRODA, C. AND C. TILLE (2003). Coping with terms-of-trade shocks in developing countries. *Current Issues in Economics and Finance* 9, 1–7.
- CLAUSERT, H. AND G. WIESEMANN (1993a). *Grundgebiete der Elektrotechnik 1*. 6th edition, Oldenbourg Verlag, Munich, Germany.
- CLAUSERT, H. AND G. WIESEMANN (1993b). *Grundgebiete der Elektrotechnik 2*. 6th edition, Oldenbourg Verlag, Munich, Germany.
- COSTINOT, A. (2009). An elementary theory of comparative advantage. *Econometrica* 77(4), 1165–1192.
- DIETZENBACHER, E., B. LOS, R. STEHRER, M. TIMMER AND G. DE VRIES (2013). The construction of world input-output tables in the WIOD project. *Economic Systems Research* 25(1), 71–98.
- EATON, J. AND S. KORTUM (2002). Technology, geography, and trade. *Econometrica* 70(5), 1741–1779.
- FEENSTRA, R.C. AND LEWIS, T.R. (1994). Trade adjustment assistance and Pareto gains from trade. *Journal of International Economics* 36, 201–222.
- FRANKEL, J.A. AND A.K. ROSE (1998). The endogeneity of the optimal currency area criteria. *The Economic Journal* 108, 1009–1025.
- FURUSAWA, T. AND LAI, E.L.-C. (1999). Adjustment costs and gradual trade liberalization. *Journal of International Economics* 49, 333–361.
- GAGNON, J.E. (1989). Adjustment costs and international trade dynamics. *Journal of International Economics* 26, 327–344.
- GOULDER, L.H. AND L.H. SUMMERS (1989). Tax policy, asset prices, and growth – a general equilibrium analysis. *Journal of Public Economics* 38, 265–296.

- HARBERGER, A.C. (1950). Currency depreciation, income, and the balance of trade. *Journal of Political Economy* 58(1), 47–60.
- KRUGMAN, P.R., M. OBSTFELD AND M.J. MELITZ (2014). *International economics: theory and policy*. 10th edition, Pearson, Prentice Hall, Global Edition, New York, USA.
- KOSE, M.A. (2002). Explaining business cycles in small open economies: 'how much do world prices matter?' *Journal of International Economics* 56, 299–327.
- KOSE, M.A. AND K.-M. YI (2006). Can the standard international business cycle model explain the relation between trade and comovement? *Journal of International Economics* 68, 267–295.
- LAURSEN, S. AND L.A. METZLER (1950). Flexible exchange rates and the theory of employment. *The Review of Economics and Statistics* 32(4), 281–299.
- MARKUSEN, J.R., J.R. MELVIN, W.H. KAEMPFER AND K. MASKUS (1995). *International trade: theory and evidence*. McGraw-Hill, New York, USA.
- MARKUSEN, J.R. AND A.J. VENABLES (2007). Interacting factor endowments and trade costs: a multi-country, multi-good approach to trade theory. *Journal of International Economics* 73, 333–354.
- MELITZ, M.J. (2003). The impact of trade on intra-industry reallocations and aggregate industry productivity. *Econometrica* 71(6), 1695–1725.
- METZLER, L.A. (1950). A multiple-region theory of income and trade. *Econometrica* 18(4), 329–354.
- OECD.STATEXTRACTS (2014). Key Short-Term Economic Indicators. <http://data.oecd.org/> (accessed Dec. 2014).
- OBSTFELD, M. (1982). Aggregate spending and the terms of trade: Is there a Laursen-Metzler effect? *Quarterly Journal of Economics* 97(2), 251–270.
- TIMMER, M.P., ED. (2012). The World Input-Output Database (WIOD): contents, sources and methods. <http://www.wiod.org/database/> (accessed Dec. 2014).
- ZESTOS, G.K. AND X. TAO (2002). Trade and GDP Growth: Causal Relations in the United States and Canada. *Southern Economic Journal*, 68(4), 859–874.

11 Figures

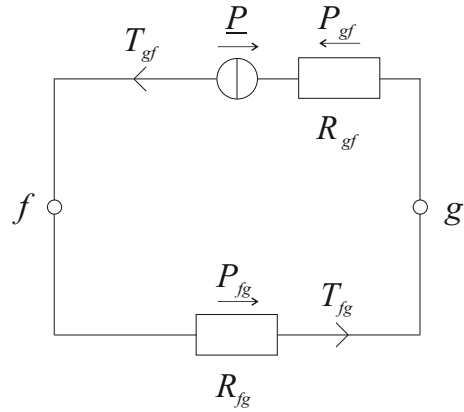

Figure 1: The figure shows the simplest possible trade network. f and g are the names of two economies, T denotes a directed trade flow that follows the straight lines through the network, \underline{P} together with the circular symbol depict an exogenous, directed price differential, P denotes a directed, induced price differential, and R together with the rectangular symbol depict a trade resistance.

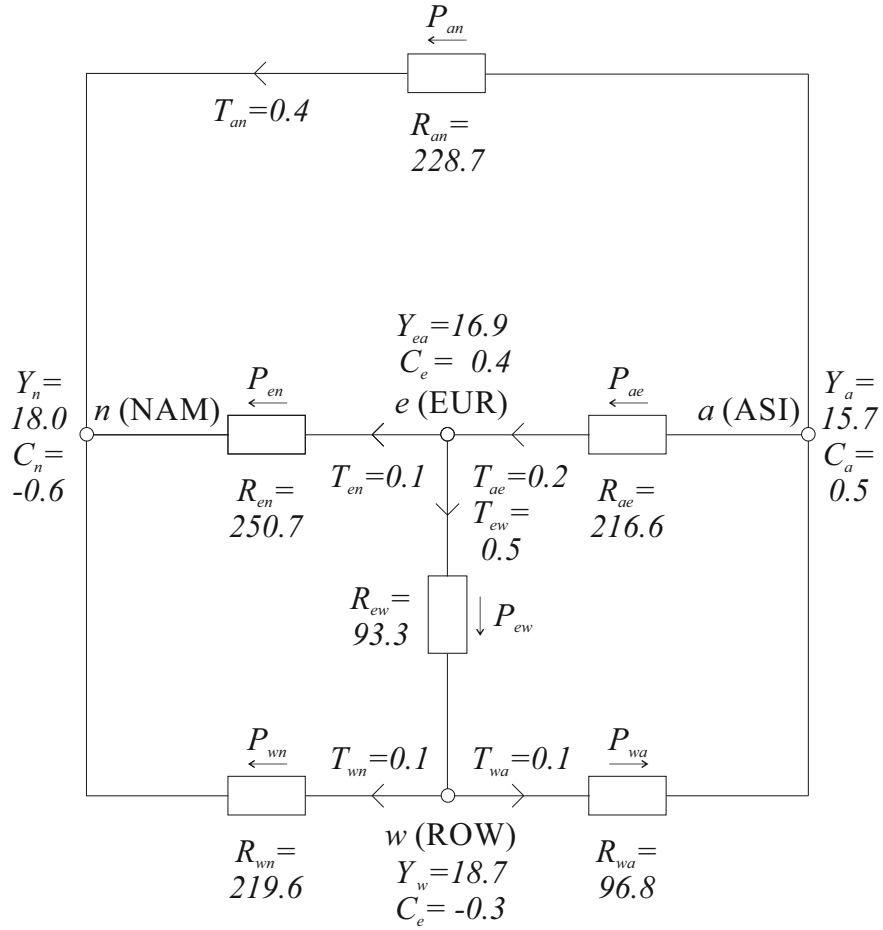

Figure 2: The figure shows an agminate global trade network. The data are taken from WIOD for the year 2011. In the center e (EUR) symbolizes the European Union 27, n (NAM) denotes North America, a (ASI) Asia, and w (ROW) the rest of the world (positioned as Africa). T denotes a trade flow, P a price differential, R a trade resistance, Y GDP and C a current account surplus.

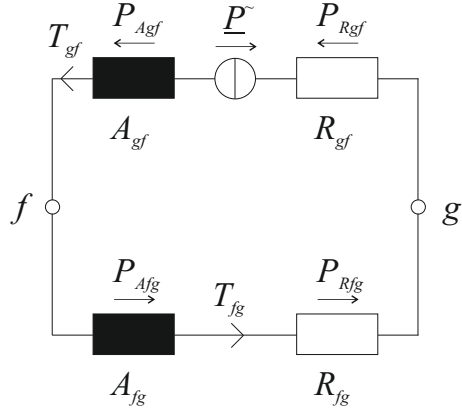

Figure 3: The figure shows a simple dynamic trade network. f and g are the names of two economies, T denotes a trade flow, \tilde{P} an exogenous time-variant price differential, P an induced price differential, R a constant trade resistance, A a dynamic trade resistance associated with adjustment costs.

12 Appendix

Solution of the welfare maximization problem in Section 6, Optimal tariffs:

We start with Equation 14:

$$W_{na} = P_{na} \cdot T_{na} = R_{na} \cdot (T_{na})^2 = R_{na} \cdot \left(\frac{R_s}{R_s + R_{na}} \cdot \underline{T}_{an} \right)^2$$

Let us assume that $R_s > 0$, $R_{na} > 0$ and $\underline{T}_{an} > 0$. The first derivative with respect to the trade resistance under examination leads to:

$$\begin{aligned} & \frac{\partial W_{na}}{\partial R_{na}} && = 0 \\ \Rightarrow & (\underline{T}_{an})^2 \cdot \frac{R_s^2 \cdot (R_s + R_{na})^2 - R_{na} \cdot R_s^2 \cdot 2 \cdot (R_s + R_{na})}{(R_s + R_{na})^4} && = 0 \\ \Rightarrow & R_s^2 \cdot (R_s^2 + 2 \cdot R_{na} \cdot R_s + R_{na}^2) - 2 \cdot R_{na} \cdot R_s^3 - 2 \cdot R_{na}^2 \cdot R_s^2 && = 0 \\ \Leftrightarrow & R_s^2 \cdot (R_s^2 + 2 \cdot R_{na} \cdot R_s + R_{na}^2 - 2 \cdot R_{na} \cdot R_s - 2 \cdot R_{na}^2) && = 0 \\ \Rightarrow & R_s^2 - R_{na}^2 && = 0 \\ \Leftrightarrow & (R_s + R_{na}) \cdot (R_s - R_{na}) && = 0 \end{aligned}$$

It follows Equation 15 describing the optimal tariff condition. \square

Setup and solution of the linear equation system of Section 7.3, Business cycles, based on the superposition principle:

In Figure 5 we first set $\underline{P}_2 = 0$ and seek a solution for the price differentials and trade flows in the network with a given \underline{P}_1 . We select two closed loops, in which the price differentials add up to zero according to Equation 8:

$$P_{ne} = \underline{P}_1 - P_{en} \quad (29)$$

$$P_{ae} = P_{an} - P_{en} \quad (30)$$

We apply Equation 4, stating that the trade flows add up to zero, to knot e (EUR). We then use Equation 3 to replace trade flows by price differentials divided by trade resistances:

$$\begin{aligned} T_{en} &= T_{ne} + T_{ae} \\ \Leftrightarrow \frac{P_{en}}{R_{en}} &= \frac{P_{ne}}{R_{ne}} + \frac{P_{ae}}{R_{ae}} \end{aligned} \quad (31)$$

In the first two equations below we rewrite P_{an} (leading from a to n via w) and T_{ae} with the help of Equation 3. In the third equation we derive the substitute resistance R_2 , which encompasses all resistances between a (ASI), w (ROW) and n (NAM), with the help of Equations 6 and 7 (\parallel symbolizes a parallel setting)):

$$\begin{aligned} P_{an} &= -T_{ae} \cdot R_2 \\ \Leftrightarrow P_{an} &= -\frac{P_{ae}}{R_{ae}} \cdot R_2 \\ R_2 &= R_{wn} + (R_{wa} \parallel R_{aw}) = R_{wn} + \frac{R_{wa} \cdot R_{aw}}{R_{wa} + R_{aw}} \end{aligned} \quad (32)$$

Thus, we have four linear enumerated equations, 29 to 32, with four unknowns, P_{ne} , P_{en} , P_{ae} and P_{an} . We insert 32 into 30 to eliminate P_{an} . We insert the resulting expression

into 29 to eliminate P_{en} . We then eliminate P_{en} and P_{ne} in 31 and obtain:

$$\begin{aligned}
P_{ea1} &= -P_{ae} = \underline{P}_1 \cdot V_1 \\
\frac{1}{V_1} &= R_{ne} \cdot \left[\left(1 + \frac{R_2}{R_{ae}} \right) \cdot \left(\frac{1}{R_{en}} + \frac{1}{R_{ne}} \right) + \frac{1}{R_{ae}} \right] > 0 \\
T_{ea1} &= \frac{\underline{P}_1 \cdot V_1}{R_{ae}}
\end{aligned} \tag{33}$$

The solution for \underline{P}_2 follows exactly the same strategy. \underline{P}_1 is replaced by \underline{P}_2 , P_{ne} by P_{aw} , P_{en} by P_{wa} and P_{an} by P_{ew} . R_2 is renamed R_1 and encompasses the trade resistances between e (EUR), n (NAM) and w (ROW). The solution yields P_{ea2} and T_{ea2} . \square

Solution of the linear first-order differential equation of Section 8, Adjustment costs, for a given temporary and a given periodical stimulus:

When applying the Laplace transformation to Equation 24, we obtain (cf. Clausert and Wiesemann 1993b, p. 282):

$$\underline{\tilde{P}} = AR \cdot \left(p \cdot \tilde{P}_A - P_{A0} \right) + \tilde{P}_A \tag{34}$$

$\underline{\tilde{P}}$ and \tilde{P}_A are functions of the Laplace variable p . A first derivative in the time dimension corresponds to a multiplication with p in the Laplace dimension. P_{A0} is the initial value of \tilde{P}_A in $t = 0$. We solve for \tilde{P}_A :

$$\tilde{P}_A = \frac{\frac{1}{AR} \cdot \underline{\tilde{P}} + P_{A0}}{p + \frac{1}{AR}} \tag{35}$$

Let us assume that in the time dimension $\underline{P} = 0$ for $t < 0$ and $\underline{P} = \hat{P}$ for $t \geq 0$. This temporary shock is represented by a unit jump function σ multiplied by the magnitude \hat{P} in the time dimension. The Laplace transformation of σ is $\frac{1}{p}$. We thus obtain in the Laplace dimension:

$$\tilde{P}_A = \frac{\frac{1}{AR} \cdot \hat{P}}{p \cdot \left(p + \frac{1}{AR} \right)} + \frac{P_{A0}}{p + \frac{1}{AR}} \tag{36}$$

We can re-transform this equation from the Laplace to the time dimension with the help of common transformation tables. Figure 6 (a) illustrates the adjustment of T_{gf} over time for the cases of a *positive shock* and a *negative shock*. In case of a positive shock, we may assume $P_{A0} = 0$ when in the initial situation the driver is $\underline{P} = 0$ so that no price differential is induced elsewhere in the network. The multiplication of the solution for \tilde{P}_A with R yields Equation 25. \square

Having analyzed the propagation of a temporary shock, we now turn to the analysis of a periodical sine-shaped stimulus with time delay caused by adjustment costs. We want to analyze Equation 28 and rewrite it in form of polar coordinates as complex amplitudes:

$$\begin{aligned}
\tilde{P} &= \tilde{X} \cdot \tilde{T}_{gf}, \quad \tilde{X} = R - \frac{i}{\omega A} \\
\Leftrightarrow \hat{P}_s \cdot e^{i\omega t} &= |\tilde{X}| \cdot e^{i\angle(\tilde{X})} \cdot \tilde{T}_{gf} \\
\Leftrightarrow \tilde{T}_{gf} &= \frac{\hat{P}_s \cdot e^{i\omega t}}{|\tilde{X}| \cdot e^{i\angle(\tilde{X})}} \tag{37}
\end{aligned}$$

We need to calculate the magnitude (measured between zero and the maximum), $|\tilde{X}|$, and the phase shift (the change in the angle that it induces between the price differential and the trade flow), $\angle(\tilde{X})$, of the complex trade resistance, \tilde{X} . They are calculated as follows (cf. Clausert and Wiesemann 1993b, p. 20):

$$\begin{aligned}
\Re(\tilde{X}) &= R, \quad \Im(\tilde{X}) = -\frac{1}{\omega A} \\
|\tilde{X}| &= \sqrt{[\Re(\tilde{X})]^2 + [\Im(\tilde{X})]^2} \\
\angle(\tilde{X}) &= \arctan \left[\frac{\Im(\tilde{X})}{\Re(\tilde{X})} \right]
\end{aligned}$$

If $\Im(\tilde{X}) = 0$, we find $|\tilde{X}| = R$ and $\angle(\tilde{X}) = 0$ which replicates the case without adjustment costs as assumed in Sections 3 to 7. In this case, there is no phase difference between $\underline{P} = \hat{P}_s \cdot \sin \omega t$ and the induced trade flow T_{gf} in the time dimension (see Figure 6 (b), *static R*). If $\Re(\tilde{X}) = 0$, the resulting phase difference will be $\angle(\tilde{X}) = -\frac{\Pi}{2}$. In this case, the trade flow is described by a cosine-function which emerges a quarter of a period ($\frac{\Pi}{2}$ or 90°) before the sine-function of the price differential in time (see Figure 6 (b), *dynamic A*). In $t = 0$ the price differential is zero, while its slope has its maximum of one. In general,

it is $\Re(\tilde{X}) > 0$ and $\Im(\tilde{X}) < 0$. Then the resulting function of T_{gf} emerges between these two cases in time (see Figure 6 (b), R and A). \square

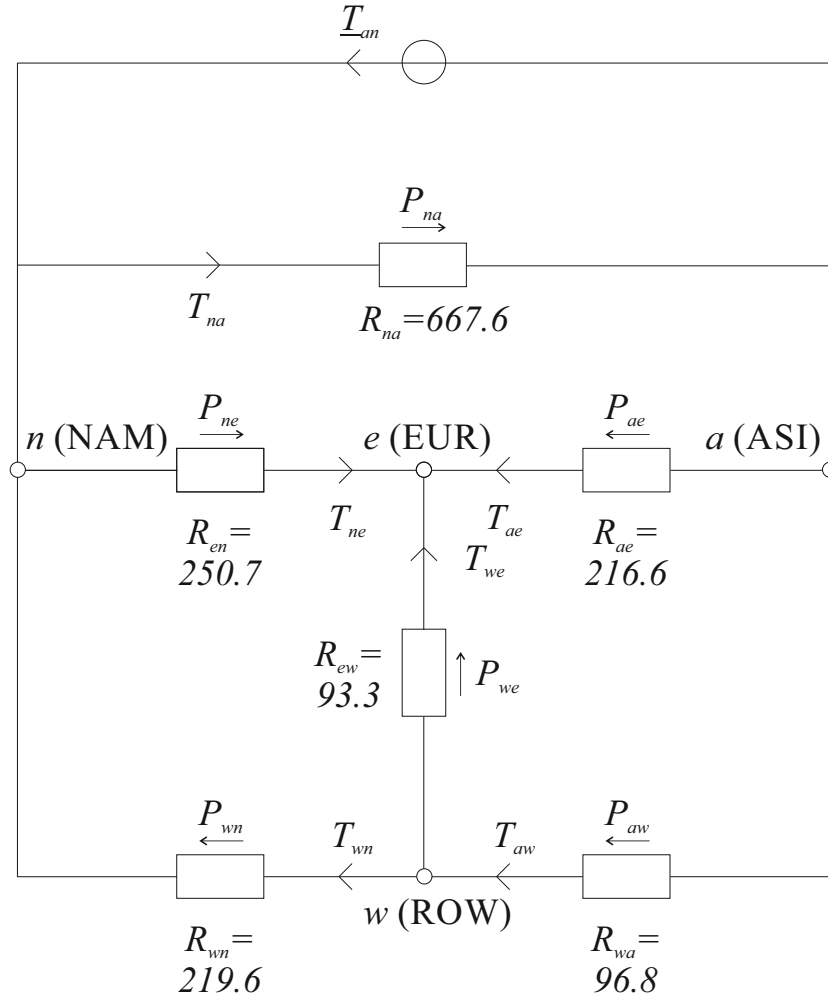

Figure 4: The figure shows the modified global network for the analysis of increased trans-Pacific trade in Section 5.

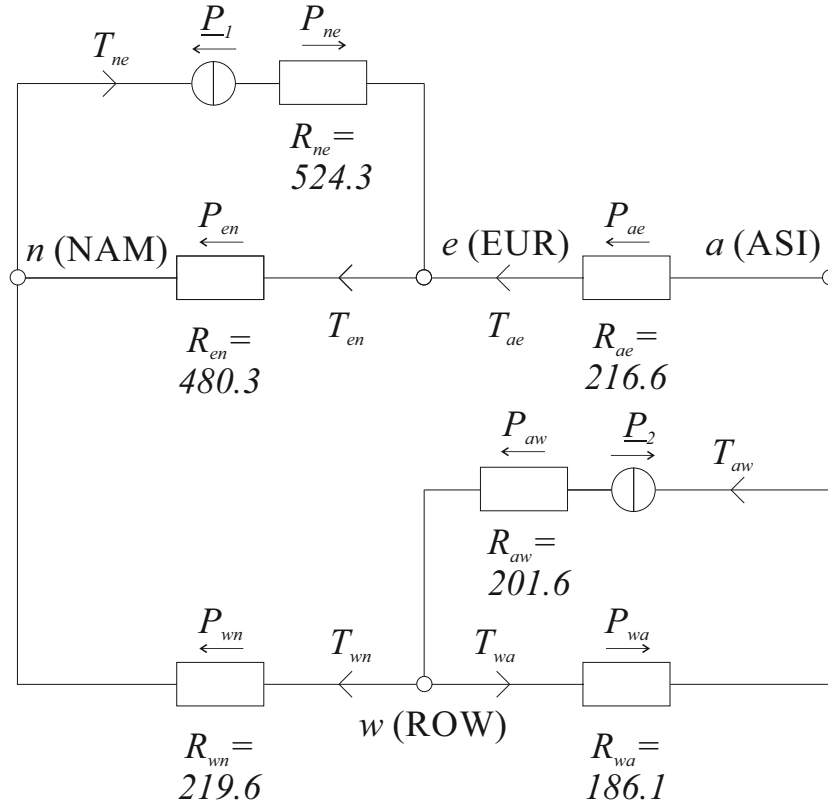
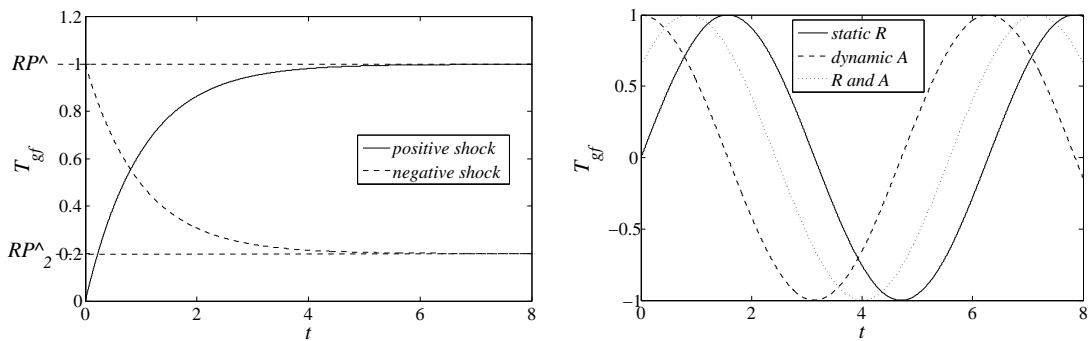

Figure 5: The figure shows the modified global network for the analysis of business cycles in Section 7.3.



(a)

(b)

Figure 6: The figure shows the solutions of the differential equation of Section 8 for T_{gf} given a jump of \underline{P} in $t = 0$ in (a) and a sine-function in (b) ($A \cdot R = 1$, $\hat{P}_s = 1$).