

Capek, Jan

**Conference Paper**

## Regional E-Government - some problems from Czech regions point of view

44th Congress of the European Regional Science Association: "Regions and Fiscal Federalism",  
25th - 29th August 2004, Porto, Portugal

**Provided in Cooperation with:**

European Regional Science Association (ERSA)

*Suggested Citation:* Capek, Jan (2004) : Regional E-Government - some problems from Czech regions point of view, 44th Congress of the European Regional Science Association: "Regions and Fiscal Federalism", 25th - 29th August 2004, Porto, Portugal, European Regional Science Association (ERSA), Louvain-la-Neuve

This Version is available at:

<https://hdl.handle.net/10419/117252>

**Standard-Nutzungsbedingungen:**

Die Dokumente auf EconStor dürfen zu eigenen wissenschaftlichen Zwecken und zum Privatgebrauch gespeichert und kopiert werden.

Sie dürfen die Dokumente nicht für öffentliche oder kommerzielle Zwecke vervielfältigen, öffentlich ausstellen, öffentlich zugänglich machen, vertreiben oder anderweitig nutzen.

Sofern die Verfasser die Dokumente unter Open-Content-Lizenzen (insbesondere CC-Lizenzen) zur Verfügung gestellt haben sollten, gelten abweichend von diesen Nutzungsbedingungen die in der dort genannten Lizenz gewährten Nutzungsrechte.

**Terms of use:**

*Documents in EconStor may be saved and copied for your personal and scholarly purposes.*

*You are not to copy documents for public or commercial purposes, to exhibit the documents publicly, to make them publicly available on the internet, or to distribute or otherwise use the documents in public.*

*If the documents have been made available under an Open Content Licence (especially Creative Commons Licences), you may exercise further usage rights as specified in the indicated licence.*

## **Regional E-Government – some problems from Czech regions point of view**

Jan Čapek

Institute of System Engineering and Informatics, University of Pardubice  
Pardubice, 53210, Czech Republic

### **ABSTRACT**

The e-government should start with electronic collaboration of governmental departments. Several services, like email, video conference, discussion forums, use of shared documents, etc. should be supported for assisting the efficient and productive collaboration of remote governmental departments. Since the functionality of the provided services is well known, no detailed description of each service phase is provided. The services for citizens are offered through so called governmental portals. The typical use of a governmental portal is to provide information to the citizens and to support several types of citizen–government transactions (e.g. issuing birth certificates, submitting tax forms, conducting electronic payments, etc.). These services open security requirements for an e-Government platform. Their compilation has been based on the security requirements derived for each independent service suite, for the Authentication processes

### **1. INTRODUCTION**

The government functioning and systems has been undergoing a rapid transformation in the past ten years within the Czech Republic. This is due to not only political changes (which have been most important) but also the impact of the technological changes that enabled delivery of services over the Internet. The private sector has taken great strides in utilizing these technologies to the development of their functioning. New service industries, better delivery of services and faster, cheaper communication are some of the by-products of the technological revolution. These transformations have created an expectation among citizens for a better delivery of services from government. Czech Parliament accepted during the year 2000 e-signatures act. Ministers of EU Member States, EFTA and countries in accession negotiations with the EU recalled the Resolution of European Ministers of Public Service and Administration and agreed that higher priority should be given to e-Government issues in further development of the Lisbon Strategy. The Lisbon strategy consists of four main tasks: firstly, the development of Internet-based services to improve access to public information and services; secondly, the improvement of transparency of public administration by using the Internet; thirdly, full exploitation of information technology within public administration; fourthly, establishing e-procurement.

This strategy is clear from the top or better speaking state governmental point of view; however, most local governments have been very slow or even unprepared for these transformations and/or strategy. Despite the increasing efforts of adopting web technology in recent years, most local government efforts have concentrated on putting up a web page. The content of these web pages concern mostly information about towns from tourism point of view and less information focus to citizen of these towns needs. For example is easy to book accommodation within plenty of hotels on-line via the Internet, and make some transactions on-line via the Internet like buying books and/or some goods from virtual shops, but it is still far from the e-Government.

The e-government should start with electronic collaboration of governmental departments. Several services, like email, video conference, discussion forums, use of shared documents, etc. should be supported for assisting the efficient and productive collaboration of remote governmental departments. Since the functionality of the provided services is well known, no detailed description of each service phase is provided. The services for citizens are offered through so called governmental portals. The typical use of a governmental portal is to provide information to the citizens and to support several types of citizen–government transactions (e.g. issuing birth certificates, submitting tax forms, conducting

electronic payments, etc.). These services open security requirements for an e-Government platform. Their compilation has been based on the security requirements derived for each independent service suite, for the Authentication processes.

## **2. DEFINITIONS**

According [2] the term “*e-government*” focuses on the use of new information and communication technologies (ICTs) by governments as applied to the full range of government functions. In particular, the networking potential offered by the Internet and related technologies has the potential to transform the structures and operation of government.

## **3. OBJECTIVES**

The objective of the introduction of the e-government to the everyday life is long term process. The objective will cover the full range of government/administration activity, covering functions such as the delivery of services, policy making and regulation and internal factors such as administrative structures, administrative processes and managerial capacity. The impact of e-government will be assessed on both governments and stakeholders, for example, the impact on both service delivery agencies and service users. However, the project will not analyse the impact of ICT use in society on specific policy decisions in areas such as health and education. The objective will concentrate on the impact of e-government at the local level, although it will also explicitly look at relations between national and local levels of government insofar as they are partners in meeting national policy objectives. The organisational and financial costing-ness generate following sub-goals.

### ***3.1 Administration***

The European Union itself is a good example in providing digital access to documents of her institutions, to "frequently asked questions" information, and to statistical data. Similar programmes have been launched in other countries, also outside the European Union, for instance in the United States [5].

A second yet more difficult issue is to put citizens into the position to fully communicate with public authorities, including that they can file applications, make payments, and more [2]. However, a number of problems are still to be solved, for instance electronic signatures and other security concerns. What seems feasible in the near future is that citizens and enterprises may keep track of their applications digitally [3]. Some states have implemented services like electronic land register and electronic commerce register. Within the Czech Republic regions, some region has electronic land register and most of them will finalise electronic access to these registers. The rising pressure on administrative costs both inside and outside the public sector is one of the main drivers and a major obstacle at the same time. On the one hand, the public requires administration to become more cost efficient; on the other hand, the transition to digitally run processes involves investments that in turn require additional capital [4]. In this matter, learning from a more developed yet much simpler field may prove fruitful: At the same time, there is often (too) rapid action on the political level, for instance, generating ideas, but politicians often hesitate when it comes to supply appropriate funding. Therefore, the vision of the European Council concerning "e-government," "Information Society," or whatever slogan is used, may be quite far ahead of being put into practice. This is mirrored by the current action plans, where often little is said about concrete steps to implement strategies.[1]

### **3.2 Infrastructure**

Infrastructure is another high-priority subject, although for different reasons: For the most countries in the European Union, infrastructure generally means to bring electronic communication closer to the citizens, for instance, to promote home computers with Internet access or to provide public connections to electronic services. For the Czech Republic the improvement of infrastructure implies supply with communication network, privatisation in the field of telecommunication, make the Internet more accessible through access costs. In the Czech Republic the level of equipping citizens by the home computers within regions very varies, as well.

### **3.3 Education**

Education is important area for the ability to make operation with computer for the e-government. This issue involves training of IT professionals on the one hand as well as computer-based education in schools and at universities on the other. Governments also strive to reduce regional disparities concerning education. To be successful in their new role within a more effective and more transparent administration, former government officials, now "public managers," also need to develop new skills [6] [15].

### **3.4 Economy**

Electronic business, as a broad term for a variety of commercial uses of telecommunication, is became more frequently used. Many peoples hope that this relatively new area brings new jobs within the telecommunication and/or computer sector.

## **4. THE LOCAL E-GOVERNMENT PLATFORM**

As suggested in Ref. [7], the architecture of an integrated on-line e-Government service platform was modify for local e-government purpose and is depicted in Fig. 1. Users (who can either be citizens or employees of public authorities) can utilise the supported e-government services through a global entrance point: the governmental portal. The portal can be either accessed through the local network or remotely through the Internet or even through other type of wireless devices like mobile phones. Normally, the 'e-government services' are supported through several collaborating (in terms of information exchange) client-server information systems [12]. This conventional client-server architecture assumes to know where computing and storage power is located. However, the continuously increasing user requirements, in conjunction with the huge number of potential users, impose the need for evolved computational models that can transparently access distributed computational and storage resources.

### **4.1 Access to information**

Citizens can access to the information offered by e-government by their home computer through Internet or by mobile device or through the information kiosks.

The information kiosks, or public access kiosks, are located in public thoroughfares, shopping malls, airports, railways stations and other locations as a substitute for, or to complement, customer service through a human service agent. In contrast to the other public access information arena, the Web accessed in the home or office, kiosks have received little media, professional or academic attention. Early kiosks, such as those reviewed by Rowley [8] were typically uninteresting boxes with relatively simple interfaces, designed specially to allow customers to conduct a simple transaction, such as placing an order, or locating a specific item of information, such as a recipe or a repayment rate for a mortgage (Rowley & Slack, 2000). The kiosks that are now making an appearance represent a significant change of perspective on the role and nature of kiosks. These 21st century kiosks, support multiple functions

including most or all of: information provision, interaction between user and consumer to support the customisation of information, transactions (such as ticket purchase), and relationship building through loyalty schemes or other communication

### 4.1.1 Portals

The interface between clients and the government is usually made through portal. It will be accessed through Internet-based technologies, use websites to bring information together and a gateway to provide a common interface to the back-office systems operated by government departments and agencies. The local government portal will also present publicly available information.

In Czech Republic exist many portals of local authorities (eg, from towns to municipalities, from regions and districts to small land users, from business private sector portal to travel agency) [13] [14]. In the last days the local government are try merge some of this portal together.

A portal may offer the client facilities to personalise the way they view the site [10]. This will allow the site designers to bring to the attention of the client new and changing content that the client has labelled interesting to them. This type of personalisation can be based around 'life events', such as I'm Having a Baby or I'm Moving House so that content (including advertising) and transactions relevant to these events could be displayed to the client. Such transactions may require processing by more than one government department.

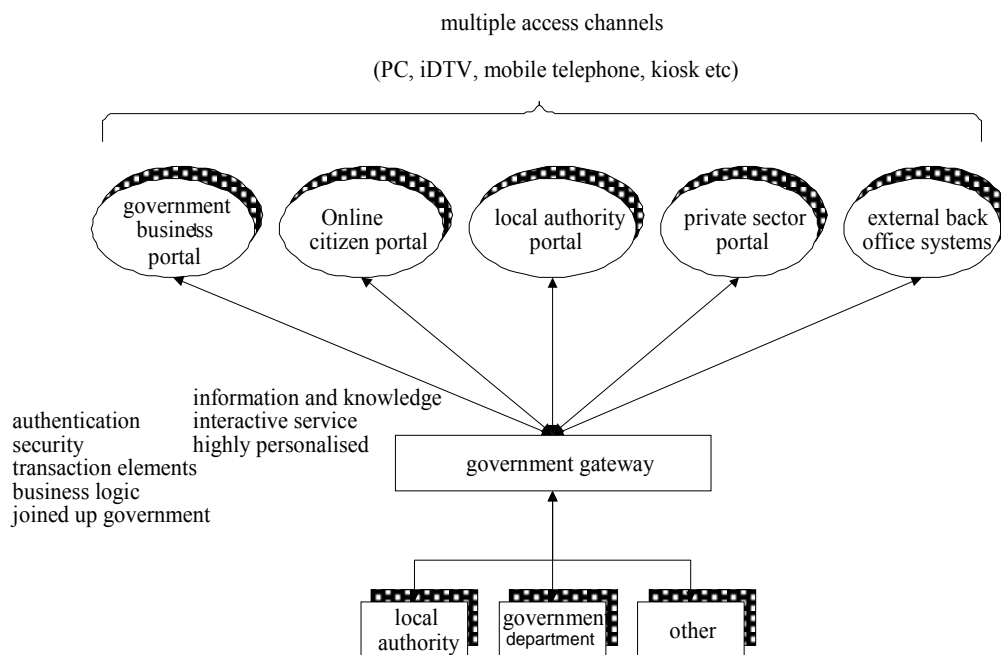

Figure 1: Portal and government gateway architecture

### Example

An example of the detail information is car recycling system within region. The problem of the old and used cars becomes crucial problem from regional point of view. As regards the expected number of cars subject to recycling, there are the following three principal sizes of enterprises: SDS - small dismantling station, DS - dismantling station, DP -dismantling plant. [11]

An DP should have a shredder for motor car scrap. The distance of SDS and DS from DP should not be longer in the final than 100 km. All the enterprises are interconnected by a computer network. There is close co-operation between particular SDS, DS and DP as regards information and preparation for transport of parts, materials and organisation of the transport, in particular. There is also necessary very

close co-operation with many enterprises reprocessing different materials, liquids, renovating parts and elements of end of live vehicles as well as utilizing the wastes. In that case organization management, information technology and logistics are going to be closely connected with technical problems. All has to be considering altogether and determine the system.

Structure of National Organised Car Recycling System presents **Error! Reference source not found.**

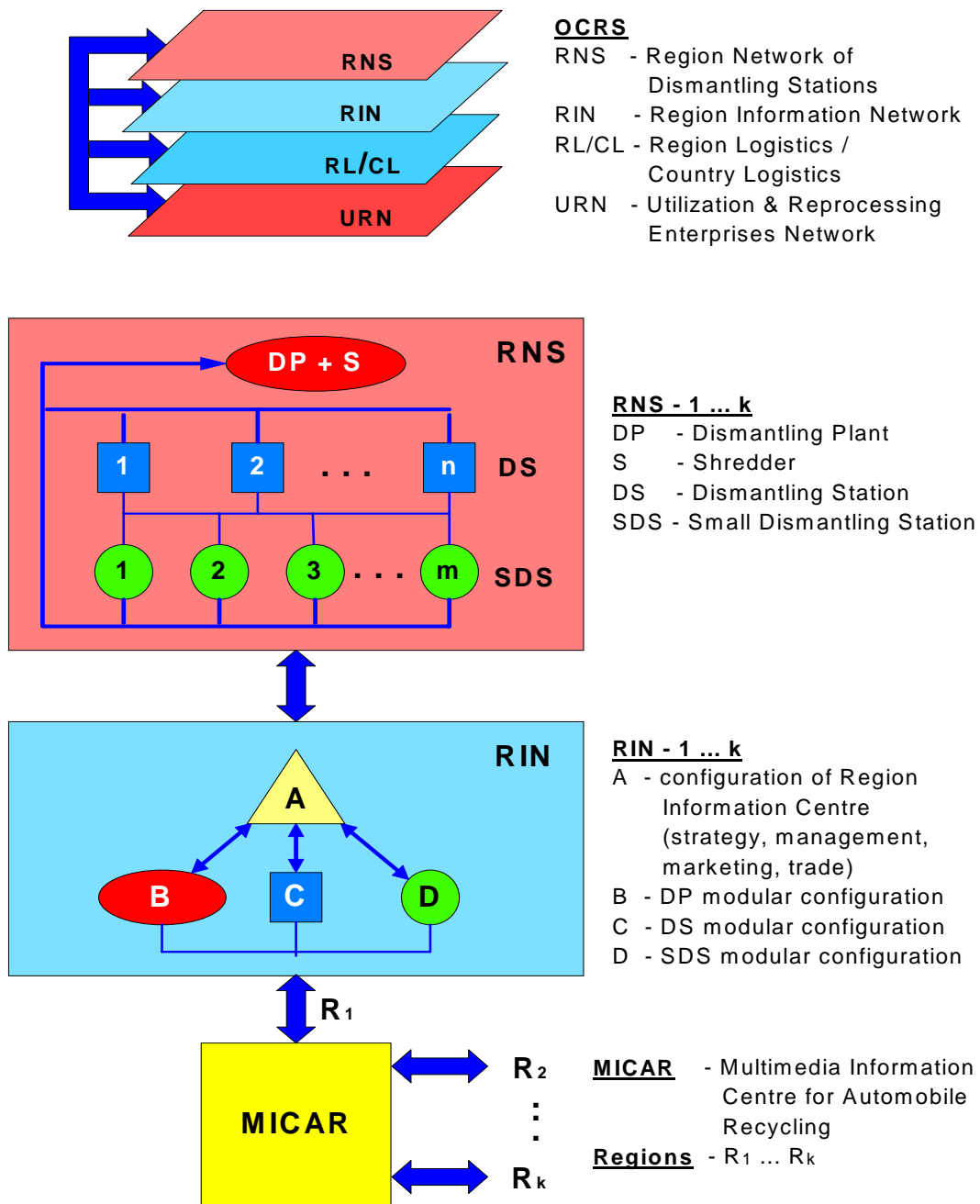

Fig.2 Structure of National Organised Car Recycling System

## 5 SECURITY

All jurisdictions offering e-government need to implement security measures to protect against external and internal threats, and higher risk sites will require greater security than others. Local governments should assess risks to their Web sites and related equipment and databases. Based on that assessment, they should develop security policies to protect their investments. Local governments should

install "firewalls," use up-to-date antivirus programs and be prepared for security incidents. They should manage employee access to the Web site and related data. Local governments should test security measures and provide for outside parties to assess whether security is sound.

### **5.1 The Public Key Infrastructure (PKI)**

The user requirements, for several distinct application domains, that a PKI should fulfil have been widely recorded in the literature. However, most current attempts to specify the desirable set of PKI services have not been based on the user-security requirements it has been reported that the 'minimal set' of user requirements includes authentication of users, integrity of messages, privacy and confidentiality of messages, no repudiation of message origin and destination, availability of services and ease of use. Furthermore, issues like anonymity, time-stamping, uniqueness of documents, interoperability between different elements, protection from abuse of any participant by another and several legal constraints have been identified as important. It can be noticed that the majority of e-government security requirements can be fulfilled through the available PKI services. Still, there are requirements like availability, performance, un-traceability, anonymity, etc. that cannot be fulfilled.

Another problem connected with local e-government is building and maintenance the data warehouses for using within the local governmental portals. The details of the problems mentioned above will be fully discussed in the presentation.

## **6. CONCLUSIONS**

The contribution shows that the introduction of the e-government into the every day life is still far from the users. The problems connected with making the e-government into the praxis is solved step by step according the needs of countries. It is supposed the at the first will be fully work e-government within the high developed counties which means not only high developed from material point of view, but also from spiritual point of view or better speaking educational point of view.

## **7 ACKNOWLEDGMENT**

This contribution was created with a kind support of Grant Agency of the Czech Republic, grant Nr. GACR 402/02/1460

## **8. REFERENCES**

- [1] G. Strejcek , M. Theil, „Technology push, legislation pull? E-government in the European Union“, **Decision Support Systems**, Volume 34, Issue 3 , February 2003, Pages 305-313
- [2] \_Council of the European Union, Commission of the European Communities, E-Europe 2002. „An Information Society for All. Action Plan prepared by the Council and the European Commission for the Feira European Council Brussels (2001)“  
[[http://europa.eu.int/information\\_society/eeurope/action\\_plan/pdf/actionplan\\_en.pdf](http://europa.eu.int/information_society/eeurope/action_plan/pdf/actionplan_en.pdf)].
- [3] M. Falch , A. Henten , „Digital Denmark: from information society to network society“. **Telecommun. Policy** **24** (2000), pp. 377–394.
- [4]H. Klages , E. Löffler , „Obstacles to the administrative modernization process in Germany“. **Int. Public Manag. J.** **1** 2 (1998), pp. 165–176.
- [5]L. Mon , „Digital reference service“. **Gov. Inf. Q.** **17** 3 (2000), pp. 309–318
- [6]\_C. Reichard , „Education and training for new public management“. **Int. Public Manag. J.** **1** 2 (1998), pp. 177–194.
- [7]\_M. Van As , J. Tillema , „Dutch telecoms law report.“ **Comput. Law Secur. Rep.** **14** 4 (1998), pp. 254–258.
- [8] Rowley, J. „Multimedia kiosks in retailing.“ **International Journal of Retail & Distribution Management**,1995 23(5), pp.32–40.

- [8] Smith, A.. **Human-computer factors**. New York: McGraw-Hill. 1997
- [9] F. Slacka, J. Rowley, „Kiosks 21: a new role for information kiosks?“ **International Journal of Information Management 22 (2002) 67–83**
- [10] [www.ukonline.gov.uk](http://www.ukonline.gov.uk)
- [11] Stokic, D., Kolbeckel, H. (eds.) Q-REC Implement Final Report , **ATB Bremen Report No: PR5-ATB-01.00/1**, Bremen 2000.
- [12] Fabian P. “Design and Developmnet of Educational Multimedia Application for Telelearning” **Workshop proceedings TEMPUS INSYPA Huddersfield 1999, pp 88-100. ISBN 80-7194-203-0**
- [13] [www.naseeva.cz](http://www.naseeva.cz)
- [14] [www.epusa.cz](http://www.epusa.cz)
- [15] Fabian P. “Proposal of the System for Education Quality Improvement” **Workshop proceedings TEMPUS INSYPA Huddersfield 1999, pp 56-60 ISBN 80-7194-203-0**