

Mariotti, Ilaria

**Conference Paper**

## Firm migration patterns in in the Netherlands and in the United Kingdom. An end of twenty calm years of geographical interest

41st Congress of the European Regional Science Association: "European Regional Development Issues in the New Millennium and their Impact on Economic Policy", 29 August - 1 September 2001, Zagreb, Croatia

**Provided in Cooperation with:**

European Regional Science Association (ERSA)

*Suggested Citation:* Mariotti, Ilaria (2001) : Firm migration patterns in in the Netherlands and in the United Kingdom. An end of twenty calm years of geographical interest, 41st Congress of the European Regional Science Association: "European Regional Development Issues in the New Millennium and their Impact on Economic Policy", 29 August - 1 September 2001, Zagreb, Croatia, European Regional Science Association (ERSA), Louvain-la-Neuve

This Version is available at:

<https://hdl.handle.net/10419/115183>

**Standard-Nutzungsbedingungen:**

Die Dokumente auf EconStor dürfen zu eigenen wissenschaftlichen Zwecken und zum Privatgebrauch gespeichert und kopiert werden.

Sie dürfen die Dokumente nicht für öffentliche oder kommerzielle Zwecke vervielfältigen, öffentlich ausstellen, öffentlich zugänglich machen, vertreiben oder anderweitig nutzen.

Sofern die Verfasser die Dokumente unter Open-Content-Lizenzen (insbesondere CC-Lizenzen) zur Verfügung gestellt haben sollten, gelten abweichend von diesen Nutzungsbedingungen die in der dort genannten Lizenz gewährten Nutzungsrechte.

**Terms of use:**

*Documents in EconStor may be saved and copied for your personal and scholarly purposes.*

*You are not to copy documents for public or commercial purposes, to exhibit the documents publicly, to make them publicly available on the internet, or to distribute or otherwise use the documents in public.*

*If the documents have been made available under an Open Content Licence (especially Creative Commons Licences), you may exercise further usage rights as specified in the indicated licence.*

## **41st Congress of the European Regional Science**

*" European Regional Development Issues in the New Millennium  
and Their Impact on Economic Policy "*

29<sup>th</sup> August – 1<sup>th</sup> September, 2001 – Zagreb

### **Firm migration patterns in the Netherlands and in the United Kingdom. An end of twenty calm years of geographical interest**

Ilaria Mariotti\* and Cees-Jan Pen\*

[I.Mariotti@frw.rug.nl](mailto:I.Mariotti@frw.rug.nl), [C.J.Pen@frw.rug.nl](mailto:C.J.Pen@frw.rug.nl)

**Faculty of Spatial Sciences**  
*University of Groningen*

\* PhD students

#### **Abstract**

In the 1970s firm migration was an important research topic in West European economic geography. Especially in the United Kingdom, but also in the Netherlands, Germany and France many migration studies are published. After the seventies, however, the interest in firm migration almost disappeared. This paper presents a comparison of firm migration process in the United Kingdom and in the Netherlands in two periods: 1945-1970s and 1980-1990s. It aims to emphasises the importance of this topic as well as the importance of comparative knowledge on firm migration process. The Netherlands and the United Kingdom have been chosen because they produced most migration studies in Europe and developed a database on firm migration. The analysis of the first period is grounded on a literary review. Firm migration databases provide information on business relocation in the two countries. The English CREDO-database presents head office migration in 1988–1999. The Mutation Balance focuses on firm migration process in 1986-1995.

## 1. INTRODUCTION

After twenty calm years of publications on the topic of firm migration, this paper presents practical evidence that besides studying topics such as clusters, trust, learning, tacit and codified knowledge, linkages, and Krugman models, economic geographers should also focus on classic themes such as firm migration. Around 1980 a period ends when many firm migration studies are published in international journals like *Regional Studies*, *Urban Studies*, *Environment & Planning*, and *Progress in Human Geography*. Authors such as Townroe, Keeble, Wood and Cooper present extensive descriptions about the amount, direction and pattern of migrating firms in the United Kingdom. Similar studies are published throughout Europe: Pellenbarg (Netherlands), Bade (West-Germany), Söderman (Zweden), and the collection about firm migration in Europe edited by Klaassen en Molle (1983) with contributions from Ireland, France, and Italy. After the seventies, scientific interest in firm migration has almost disappeared and now and then practical governmental or consultancy studies are found. Firm migration became a 'tropical' topic.

This paper presents a comparison of firm migration process in the Netherlands and in the United Kingdom. The analysis faced two main kind of problems. The first concerns the different dimensions of the two countries (i.e. the Dutch national scale is to be compared to the Southeast region in the UK). The second regards the qualitative and quantitative differences of the firm migration databases adopted. The purpose of the paper is to show that the motives of interest in firm migration research together with the importance of a comparative knowledge are more important than the difficulties associated with this study. It also suggests that the outcome of this comparison should initiate a new round of existing research.

Starting from the assumption that the migration of industries cannot be considered apart from their location, section two deals with the main theories about the location of enterprises: neo-classical, behavioural and institutional. It shows what theories have to be adopted to explain similarities and differences in firm migration process between the United Kingdom and the Netherlands. Section three defines 'firm migration' and underlines its importance in regional economic development. Section four describes firm migration databases: the CREDO database in the United Kingdom and the Mutation Balance in the Netherlands. The amount, direction and patterns of firm migration in the both the countries is described in section five. This is organised in three

subsections. The first presents a literary overview of the process in 1945-1970s. The second concerns firm migration in the last two decades (1988-1999 for the UK and 1986-1995 for the NL). These national figures are compared in the third subsection.

## 2. LOCATION THEORIES

This section focuses on the headlines of the usual location theories, because as Townroe (1972) states: *'the body of location theory is not more useful in interpreting the growing volume of empirical results on industrial movement'*. Location theories explain from different perspectives the location of economic activities and why they appear on that location. Discussions about these explanations generally describe the similarities and differences between the three general streams of location theories (Hayter, 1997): (neo)-classical, behavioural, and institutional (based on the geography of enterprise). According to Hayter (1997), each of these theories is based on different concepts of the firm in terms of abilities and motivations, different concepts of the wider economy or 'environment' in which individual firms function, and different emphases of how firms relate to this wider economy or environment.

Table 1 presents the well-known features of the three streams. A more detailed discussion about the underlying meaning of the elements presented in table 1 can be found in for example Smith (1971), Lloyd & Dicken (1992), Hayter (1997), and Pen (2000).

**Table 1: Three streams of location theories**

Features	(Neo)-classical	Behavioural	Institutional
Founder and famous authors	Alfred Weber (1909), Von Thünen, Lösch, Hotelling, Palander	Allan Pred (1979; 1969), Townroe, Keeble, Stafford, North, Dicken	Robert McNee (1968), Krumme, Galbraith, Rees, Steed, Taylor, Storper
Key concepts	Homo economicus/ optimizer/economic man, instrumental rational, fully informed	Satisficer, bounded and procedural rational, limited information, subjectivity	Technostructure, strategy, structure and power, rational choice marxism, monopoly/oligopoly
Scientific area	Micro and general economics, econometrics	Sociology, psychology (social geography)	Management & Organisation, business economics
Building stones	Minimal costs, maximum benefits, fully competition	Information, action space and aspiration level	Growth, stability and profit
Analysis	Macro, statistics, explaining spatial pattern and dynamics → modelling	Micro, fieldwork, explaining spatial behaviour → describing and interpreting	Meso, firm data, explaining spatial interaction → structuring
Method	Construct models	Interviews and surveys	Case studies
Criticism	Unrealistic assumption, focus on calculation, and neglect richness of geography	Too much opposing against (neo-)classical theory, process and firm is a black box, repetition of much of the same	Hardly applicable in practice, despite interest in firm strategy comparable criticism as the behavioural approach
Current topic	New economic geography by Krugman	Revival?	Clusters/industrial districts and the cultural turn
Interest	Increasing	Minor, but slight increase	Peak and in fashion

*Source: Elaboration on Hayter (1997), and Pen (2000).*

The limited applicability of the (neo-)classical location theory for this paper is obviously expressed by Smith (1971, p. 276): '*classical theories have been more concerned with the construction of elegant theories of location equilibrium, or with the fusion of location and production theory, than with providing a guide for empirical enquiry*'. The same appears for the so-called new economic geography: '*it is not new, and it is most certainly not geography...new economic geography contains too little region and too much mathematics*' (Martin, 1999, p. 67). Most well known migration studies such as Townroe (1971, 1976), Hamilton et. al. (1974), Keeble (1976, 1978), Pellenbarg (1985) and also Louw (1996) and Ebels (1997) are primarily based on behavioural principles. The institutional approach focuses on the interaction between firms instead of the behaviour of individual firms. The Behavioural and the Institutional location theories are adopted in the paper to explain similarities and differences in firm migration process in the Netherlands and in the UK.

### **3. DEFINING FIRM MIGRATION**

A firm can be defined as a self-governing economic organisation with a given labour force, premises and capital resources, engaged in the production of one or more goods or services (Keeble, 1974). Defining 'mobility' of industries and 'migration', however, is more complicated. According to Klaassen and Molle (1983), mobility is the degree to which entrepreneurs are declined to follow an impulse to move, and migration is the result of the propensity to move and the intensity of the impulse. Most studies about firm migration accept that movement exists of at least two forms: (1) complete relocation, which can be defined as the movement of an establishment from one location to another; (2) branch movement, whereby a new local unit, linked with a pre-existing unit, which is not eliminated, is set up (Ortona and Santagata, 1983). This paper uses these two definitions, which are presented in figure 1.

**Figure 1: Difference between relocation and branch movement**

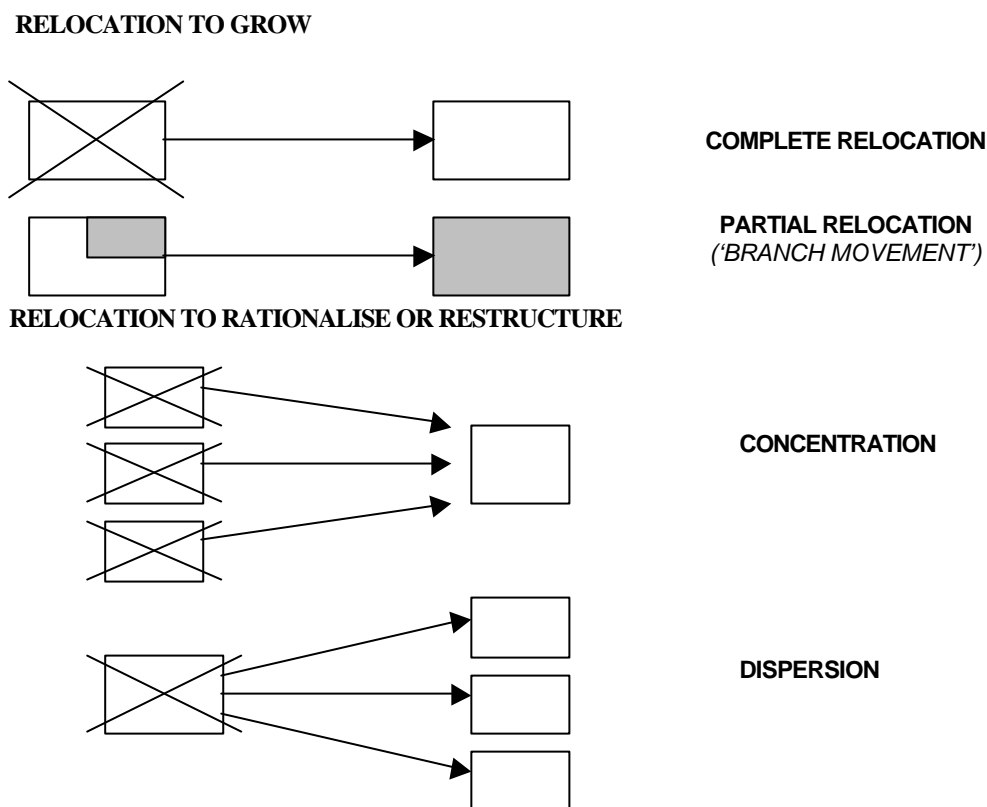

*Source: Fielding and Prism Research (1992, p.16)*

As concerns the geographical scale of firm migration, the moves by firms and plants can be ordered into at least three categories: international, interregional and intra-regional. Interregional migration has attracted a lot of attention in empirical research by professionals as well as by researchers. This attention corresponds with the object of regional development policy in the 1970s, which focuses on stimulating firms to move to assisted regions. This paper focuses on interregional migration.

Firm migration processes are normally studied on a macro or a micro level. The former uses regionally aggregated data and focuses on the development of firm migration over time and space by sector. The latter aims at understanding the factors causing firm migration. It assesses push, pull and keep factors on the basis of written questionnaires or personal interviews with managers/decision makers. Both approaches are useful, but in order to be able to record the dynamics in trade and industry accurately, it is essential to have a nation wide database first. These data can subsequently be used to identify certain patterns, which can be tested by a more micro approach.

Most European countries have set up nation wide databases of firms. Some of them went further and developed a database which registers firm migration. For instance, in the Netherlands the Chambers of Commerce set up the 'Mutation Balance'. In the United Kingdom a private consultant company developed the so-called 'Credo database' that counts company movements in the country. In other countries, no database on firm migration has been set up yet. However, in some countries such as Italy, the business register possesses the necessary qualifications for developing firm migration data. This paper focuses on firm migration in the United Kingdom and the Netherlands using primarily a macro approach.

#### 4. FIRM MIGRATION DATABASES IN THE UNITED KINGDOM AND IN THE NETHERLANDS

**Table 2: The Mutation Balance and the CREDO databases**

Database	MUTATION BALANCE (NL)	CREDO (UK)
Source	The Dutch Trade Register	Dun and Bradstreet
Years period	1986-2001*	August 1988- December 2000 (trimester)
Type of business	<ul style="list-style-type: none"> <li>▪ Head Offices</li> <li>▪ Branch plants</li> </ul>	<ul style="list-style-type: none"> <li>▪ Single Location Companies</li> <li>▪ Head Offices</li> <li>▪ Holding companies</li> </ul>
Company size	<ul style="list-style-type: none"> <li>▪ All sizes<sup>i</sup></li> </ul>	<ul style="list-style-type: none"> <li>▪ 1-250 employees</li> <li>▪ more than 250</li> </ul>
Sector	<ul style="list-style-type: none"> <li>▪ ISIC 92 (Standard Industrial Classification)</li> </ul>	<ul style="list-style-type: none"> <li>▪ ISIC 92 (Standard Industrial Classification)</li> </ul>
Spatial level	<ul style="list-style-type: none"> <li>▪ Provincial level **</li> <li>▪ National level</li> </ul>	<ul style="list-style-type: none"> <li>▪ County level</li> <li>▪ Regional level</li> <li>▪ National level</li> </ul>
Analysis undertaken	<ul style="list-style-type: none"> <li>▪ Total firm moves<sup>ii</sup> and NET firm migration (IN-OUT)</li> <li>▪ Total job moves and NET job migration</li> <li>▪ Origins and Destinations (provincial level)</li> <li>▪ List of companies into area</li> <li>▪ List of companies out of area</li> <li>▪ List of companies within area</li> <li>▪ List of all moving companies</li> </ul>	<ul style="list-style-type: none"> <li>▪ Total firm moves</li> <li>▪ Total job moves</li> <li>▪ Turnover</li> <li>▪ Origins and Destinations (regional level and county level)</li> <li>▪ List of companies into area</li> <li>▪ List of companies out of area</li> <li>▪ List of companies within area</li> <li>▪ List of all moving companies</li> </ul>

\* The last publication of data traces back to 1995.

\*\* In the classifications, the Dutch provinces can be compared to the British regions.

*Source: Prism Research (2001) and the Dutch Chambers of Commerce (2000)*

##### The Mutation Balance –Netherlands

In the Netherlands each new business (companies and their branch establishments) must be registered with the Trade Register of the Chamber of Commerce of the district in which the new business entity is located. The Netherlands has 21 Chambers of Commerce. Every one of the 21 Chambers of Commerce maintains a Trade Register for its own district. The Trade Register (or CoC register) contains information on all firms that legally, are required to register. It also covers non-profit organisations, which carry

out commercial activities, such as some associations and foundations. According to Kemper, in the 1994 the central database comprised about 800,000 business establishments, 100,000 foundations and 100,000 associations. In the year 2000 the number of establishments raised to 1.000.000 (Kemper, 2000)<sup>iii</sup>. In the mid-nineteen eighties, the Dutch Chambers of Commerce started the so-called Mutation Balance project, which produces on an annual basis national data about firm formation, firm migration and firm closure. The Regional Registrations (21 regional databases) have been assembled in the so-called National Registration of Migration in order to build a registration of firm migration. It takes into account both head offices and branch-plants. The Mutation balance is a longitudinal register. Every business has a unique code, assigned by the Chamber of Commerce, that does not change if the company relocates. It follows that through a longitudinal study it is possible to follow firm migration process (Table 2). On the basis of these data a series of publications has been written to document and analyse the firm migration process in the past ten years<sup>iv</sup>.

#### The CREDO database – United Kingdom

In the United Kingdom, Companies House is the Government agency responsible for company registration. It also has a key role in providing information about British companies<sup>v</sup>. Companies House has the public records of over 1.3 million companies and it also keeps the information on 2.6 million dissolved companies as well. Companies House holds businesses that are limited companies and so miss charities, partnerships etc. and branch plants. Every company is identified by has a unique number that will stay the same through the company's history. The firm migration database CREDO has been developed by a private consultant company: Prism Research operating from Telford in the West Midlands. Its source of information is the dataset provided by Dun and Bradstreet that concerns companies registered with the Companies House in the UK. The CREDO database records the firm relocation process since August 1988. A unique number identifies each business. By consequence, through a longitudinal study it is possible to analyse the migration processes at national, regional and county level. CREDO refers to single location companies, head quarters and holding companies (not branches). It is important to underline that CREDO database does not present a 'real job migration' because the jobs total for each business is that associated legally with that company (head office or holding company), including any branches and subsidiaries belonging to it (Table 2).



## **5. FIRM MIGRATION IN THE UNITED KINGDOM AND IN THE NETHERLANDS**

This section presents similarities and discrepancies in firm migration trends in the Netherlands and in the UK in 1945-1970s as well as in the last decade (in particular, 1989-99 for the UK and 1986-95 for the Netherlands). Before proceeding with this section, some comments are however appropriate. First, the comparison of these two countries presents a problem of dimension: the UK is much bigger than the Netherlands. Second, because of the lack of data the analysis refers to two different years periods: 1986-95 for the Netherlands and 1988-1999 for the United Kingdom. Third, two different data sources are adopted to describe firm relocation in the most recent period: the Mutation Balance for the Netherlands and the CREDO database for the UK. As chapter 4 showed the Dutch register counts both head offices and branch plants, while the Credo database only deals with corporate relocation (single location companies, head offices and holding companies). This feature leads to different results in particular as concerns the “labour migration”. Although many features may not be comparable because of data limitations, this section aims to try to gain comparative knowledge.

### **5.1 Firm migration in 1945-1970s**

Business movement and in particular manufacturing migration has been a source of considerable interest in the United Kingdom as well as in the Netherlands– both to government and to the academic community - since the end of the Second World War until the 1970s.

#### The United Kingdom

As concerns the UK, in this first period, regional policy encouraged the movement of manufacturing industry to assisted areas using the instruments of location controls, capital subsidies and labour subsidies<sup>vi</sup>. British firm migration studies are part of the numerous studies in this period, which attempt to estimate the effect of such policy instruments on the economy of the assisted areas (Armstrong and Taylor, 2000)<sup>vii</sup>. The post-war government policies focuses on (Keeble, 1971): (1) regional economic development; (2) metropolitan decentralisation and (3) the economic decline of parts of the inner areas of major British cities in 1970 to 1980. Regional economic development stimulates firms to move from the more prosperous and fast-growing parts of the country to those regions (mainly the North and West) which suffer from industrial

depression (new Development Areas or assisted areas). The second policy encourages decentralisation of both people and industry to locations beyond the existing urban fringe by the middle of the 1950s. The third approach to attract manufacturing industry back in, failed.

Forthergill and Guy (1990) estimate that in the 1945-1975 period there are 5,100 inter-regional moves in the United Kingdom involving over 800,000 jobs. The South East and in particular London, provides the major source of inter-regional industrial moves (fig.2), followed by the West Midlands (Sant, 1975). The most mobile sector in the 1960s and 1970s is the manufacturing industry sector. The driving force behind the migration process in this period is: lack of space, transport related issues and labour market problems. The first two are main causes for short distance moves in and around the core areas (industrial suburbanisation), while labour shortage is the dominant motive for long distance movements from the economic core areas to peripheral and/or development areas (industrial decentralisation) (Van Dijk, Pellenbarg and Van Wissen, 2001).

**Figure 2: Manufacturing movement to the peripheral area from the Southeast**

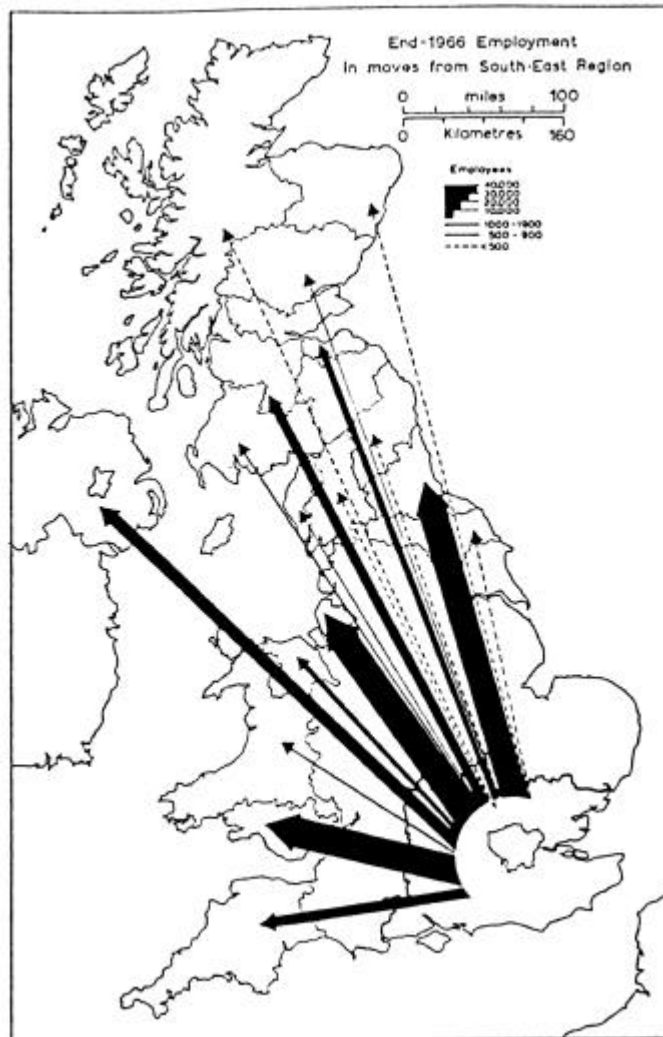

*Source: Keeble, 1972a.*

### The Netherlands

As regards the Netherlands, information on firm relocations in the Netherlands in the period 1945-1970s is rather fragmentary. Pellenbarg (1985) identifies until 1980 well over a hundred of studies on this subject. Noteworthy is the SISWO report published in 1967, which describes the migration of manufacturing firms with more than ten employees in the period 1950-1962. A few investigations focus on interregional migration of manufacturing industry, while other studies describe industrial 'overspill' around some of the large urban agglomerations (Molle, 1983; Pellenbarg, 1985). Figure 3 shows the main findings on firm migration processes in this period. According to Pellenbarg (1985), since the Second World War, two main processes characterise the geographical distribution of Dutch industry: (1) a diffusion from the Western part of the Netherlands to other parts of the country ('industrial decentralisation'); (2) a

decentralisation process in the large urban agglomerations ('industrial suburbanisation').

**Figure 3: Area coverage of studies on the volume and type of movement, 1950-1980**



Source: Molle, 1983, p. 267.

Government policy has tended to promote decentralisation with the help of regional policy and suburbanisation for reasons of physical planning (Molle, 1983). This policy more or less forced firms to move out of the city (Ebels, 1997). Regional policy failed in the 1970s, while the city renewal policy persisted during the 1970s. First, industry moved from the West to new industrial sites and outskirts of the cities mainly because of labour market problems. According to the SISWO study (1967), the interregional movements of manufacturing establishments in the 1960s accounted for some 40 per cent of the total number of moves. The West experienced a net outflow of 400 plants. The number of moves decreased if the distance increased. Second, firms migrate from urban centres to municipalities in the rings of the agglomerations or to

rural places; a suburbanisation process. The major cities involved are Amsterdam, The Hague and Utrecht. The forces governing relocation are mainly: lack of space for expansion, traffic problems and organisational reasons (mergers, acquisitions, etc.) (Molle, 1983). Industry is the most mobile sector in the 1950s and 1960s. In the 1970s mobility decreases in manufacturing industrial sectors and at the same time increases in the service sector, especially wholesale.

## **5.2 Firm Migration in the United Kingdom (1988-1999) and in the Netherlands (1986-1995)**

### United Kingdom (1988-1999)

In 1988-1999, the United Kingdom registers 251,289 firm movements, which involves 31,767,466 jobs. Figure 4 shows that the number of business movements rises during the late 1980s and the early 1990s before falling sharply in the mid- 1990s. Volumes recover slightly towards the end of 1995 and have since followed an upward tendency. The early 1990s recession is the cause of the trough between 1993 and the early 1995. Relocation is strongly associated with business growth and expansion and thus tends to fall when business confidence subsides (Prism Research, 2001).

The greater part of the moves is short distance movements within the regions (82%). Long distance moves are mostly from the Southeast to the Northern regions (Scotland, Northern Ireland, North, Yorkshire and Humberside and North West). The majority of migrant firms are single location companies and generally small. Small firms are more numerous and the logistical problems of moving are smaller than for a large and complex organisation. According to Prism Research (2001), firms with 1-4 employees account for the largest share of total movements (29%).

**Figure 4: Total volume of company relocations in the UK, 1988-1999**

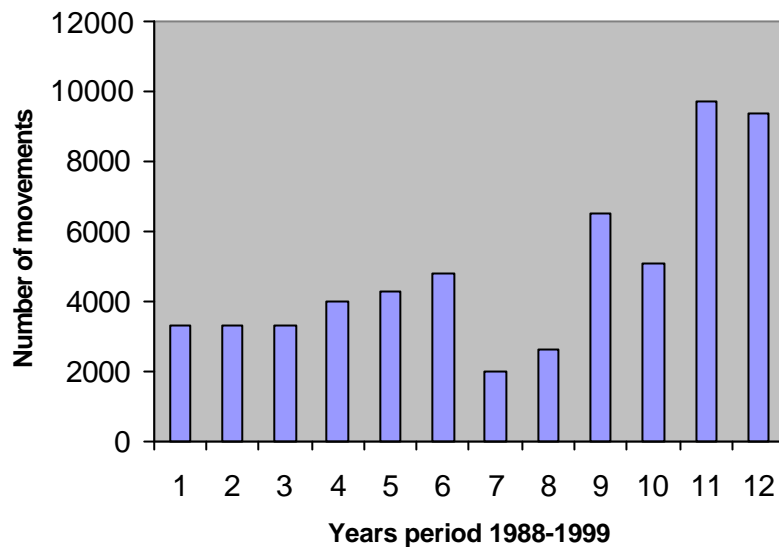

*Source: Adaptation CREDO-database*

#### *Geographical pattern*

The region that generates most migrations (in, out and within) in the period 1988-1999 is the Southeast. Movements within this region include 50% of the total movements in the UK; outward movements cover 40% and inward movements are about 26%. The Southeast experiences (1) net shift of firms from the Southeast mainly to other regions adjacent to the Southeast; (2) general shift of companies from London to north western and south western quadrants of the Southeast.

Figures 5 and 6 show respectively, net firm migration in the UK's regions and the destinations of companies leaving the Southeast region in 1988-1999. This is the only region to experience a migration deficit and the adjacent regions are more and more involved. Companies from the Southeast are mostly moving to adjacent regions. The East-Midlands experiences the highest migration surplus, followed by the Southwest, West-Midlands and East Anglia. These regions attract 'back office' administrative and data handling operations of companies. The companies are attracted by the lower costs of countries contiguous to London, but not too far from the facilities provided by the Southeast. Flows out of the Southeast in particular favour locations in a territorial segment between the M4 and the A1. This 'dominant segment' for business relocation out of the Southeast has a significant weight of public stimulus to economic development. On the other hand, Yorkshire and Wales represent a further frontier, while

distant regions gain relatively little from the process. Usually, low-added value type industries experience long distance movements for labour cost reasons and cheap premises. The assisted areas represent a preferred location for these companies.

As figure 5 shows, there is also a lower amount of firm movements towards the region itself<sup>viii</sup>. The areas where firms move to also lose firms to the Southeast. These figures are described in table 3 and figure 6. In both cases the high ranked areas are major focuses of economic activity outside the Southeast and these areas primarily contribute to inward movements (Prism Research, 1992). Moreover, figure 8 shows contradictory figures from an employment point of view. Regions such as the East-Midlands, East Anglia and the North with a firm migration surplus lose jobs, while the Southeast loses companies, but gains jobs. The possible explanation to this figures is associated to the “not real labour migration” resulting from CREDO data. A second explanation could be that the ‘relocating companies’ are smaller than companies leaving the region and *vice versa*. The Southeast on one hand attracts the administrative centres of major corporate, multi-site enterprises and on the other hand loses single location companies, due to congestion and the high cost of premises.

**Table 3: Southeast out and in migration at the regional level, 1988-1999**

Destination of outward		%		Origin of inward		%	
1	South West	1,990	21	South West	1,426	23	
2	West Midlands	1,567	17	West Midlands	946	15	
3	East Midlands	1,325	14	East Midlands	848	14	
4	North West	1,247	13	North West	768	12	
5	East Anglia	1,106	12	East Anglia	670	11	
6	Yorkshire & Humberside	871	9	Yorkshire & Humberside	616	9	
7	Scotland	459	5	Scotland	319	5	
8	Wales	425	5	Wales	303	4	
9	North	324	3	North	212	3	
10	Channel Islands	37	0.4	Channel Islands	37	0.5	
11	Northern Ireland	39	0.4	Northern Ireland	31	0.4	
12	Isle of Man	12	0.2	Isle of Man	9	0.1	
Total		9,402	100%	Total	6,185	100%	

Source: Adaptation CREDO database, 2001

**Figure 5: firm migration in the United Kingdom, 1988-1999**

**Net firm migration in the United Kingdom in 1988-1999**

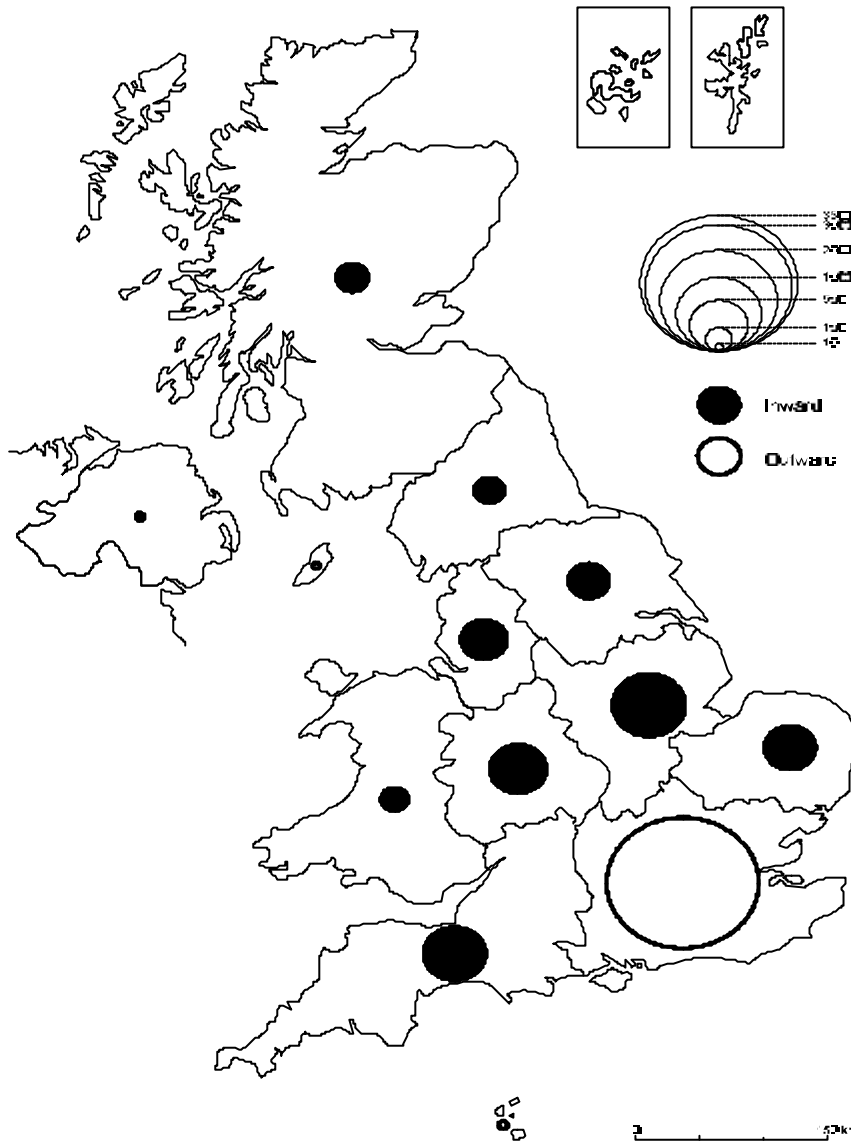

Source: Adaptation CREDO database, 2001.

On the other hand, regions such as Midlands, Southwest and East Anglia attract ‘back office’ administrative and data handling operations of companies, which often retain some kind relationship with the Southeast.

According to CREDO, in 1999, more regions experience a migration deficit compared to the years 1988-1999. The Southeast and the Northwest lose firms and jobs. Northern Ireland lose companies while, the West Midlands and Wales lose jobs. On the other hand, the job migration deficit decreases in West Midlands in comparison with the other regions. Besides, the Southwest presents a marked growth of migration surplus. This probably confirms its position of main receptor of companies leaving the Southeast.



**Figure 6: Destination of outward movement in the southeast, 1988-1999**

South East: Destination of outward firm movements (1988-1999)

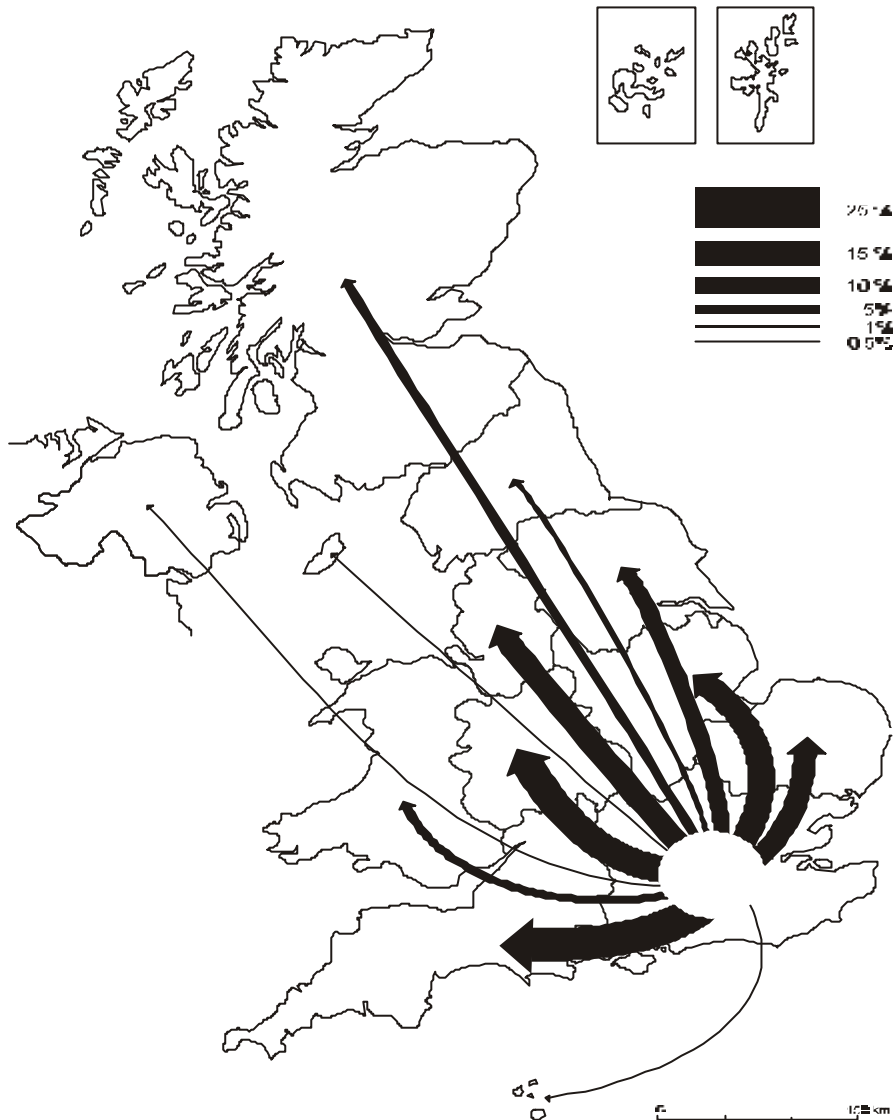

Source: Adaptation Credo database, 2001.

As concerns movements within the Southeast, most companies tend to move outside London due to congestion, high house prices, high costs of labour, high staff turnover and the inadequacy of old(er) buildings for modern operations. These factors explain that the city capital is more and more an unattractive living environment. The companies that actually move out of the region often retain some kind of operation and only locate the low value added operations in other parts of the United Kingdom.

Within the Southeast, we identify the same interaction between infrastructure and business movement: the pull of Heathrow and Gatwick in attracting businesses with international orientations; the motorways (M3 and M23) as an attractive location for companies and a sufficient link to the conurbation. Moreover, agglomeration economies are an important location factor in the Southeast. The printing industry, the financial

service sector and the publishing industry tend to stay in London, while IT companies locate in the so-called 'Heathrow Hedge' area (including the areas of Gatwick and all the major airports).

**Figure 7: Origin of inward firm movements to the Southeast, 1988-1999**

South East: Origin of inward firm movements (1988-1999)

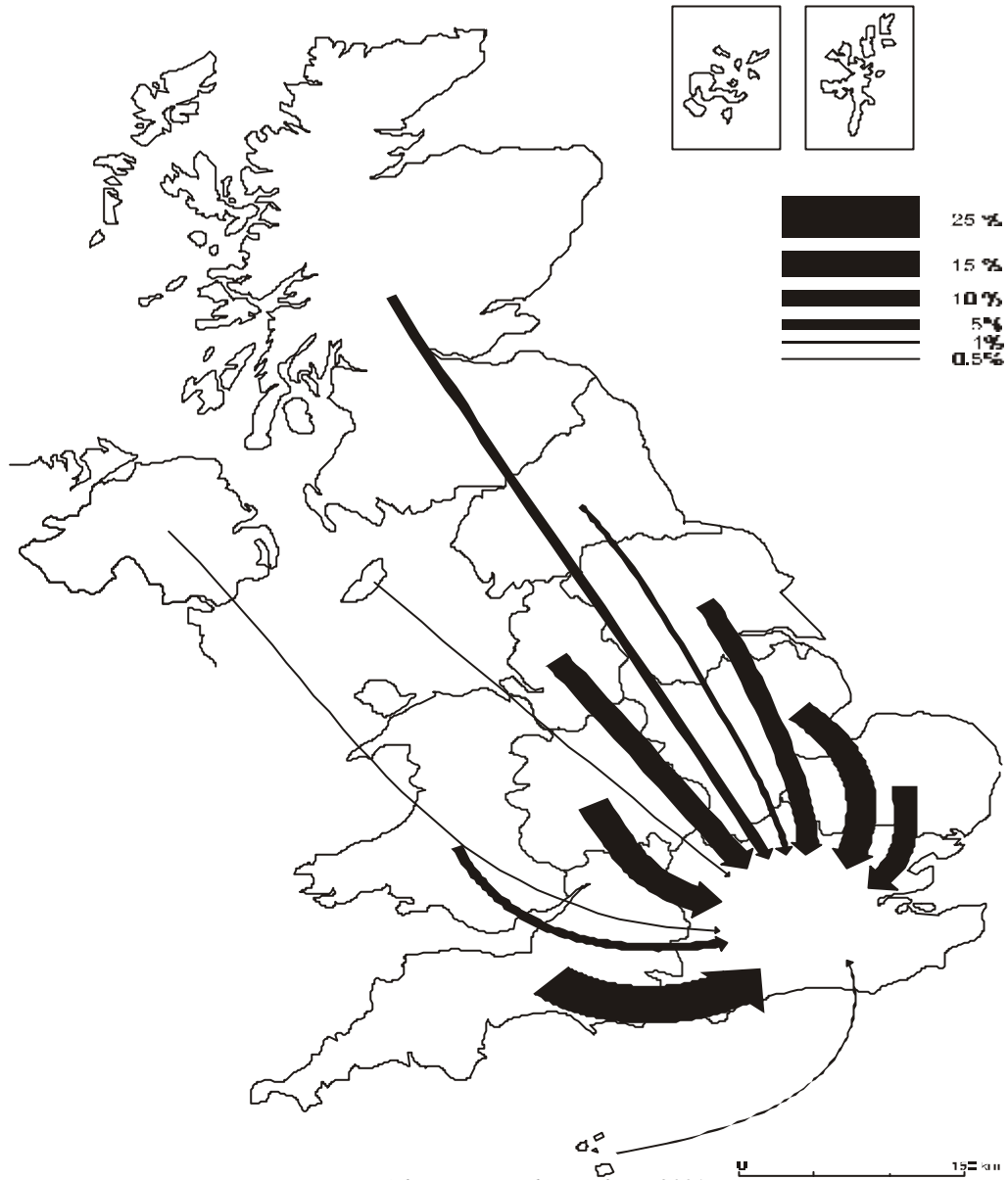

**Figure 8: Net job migration in the United Kingdom, 1988-1999**

Net job migration in the United Kingdom in 1988-1999

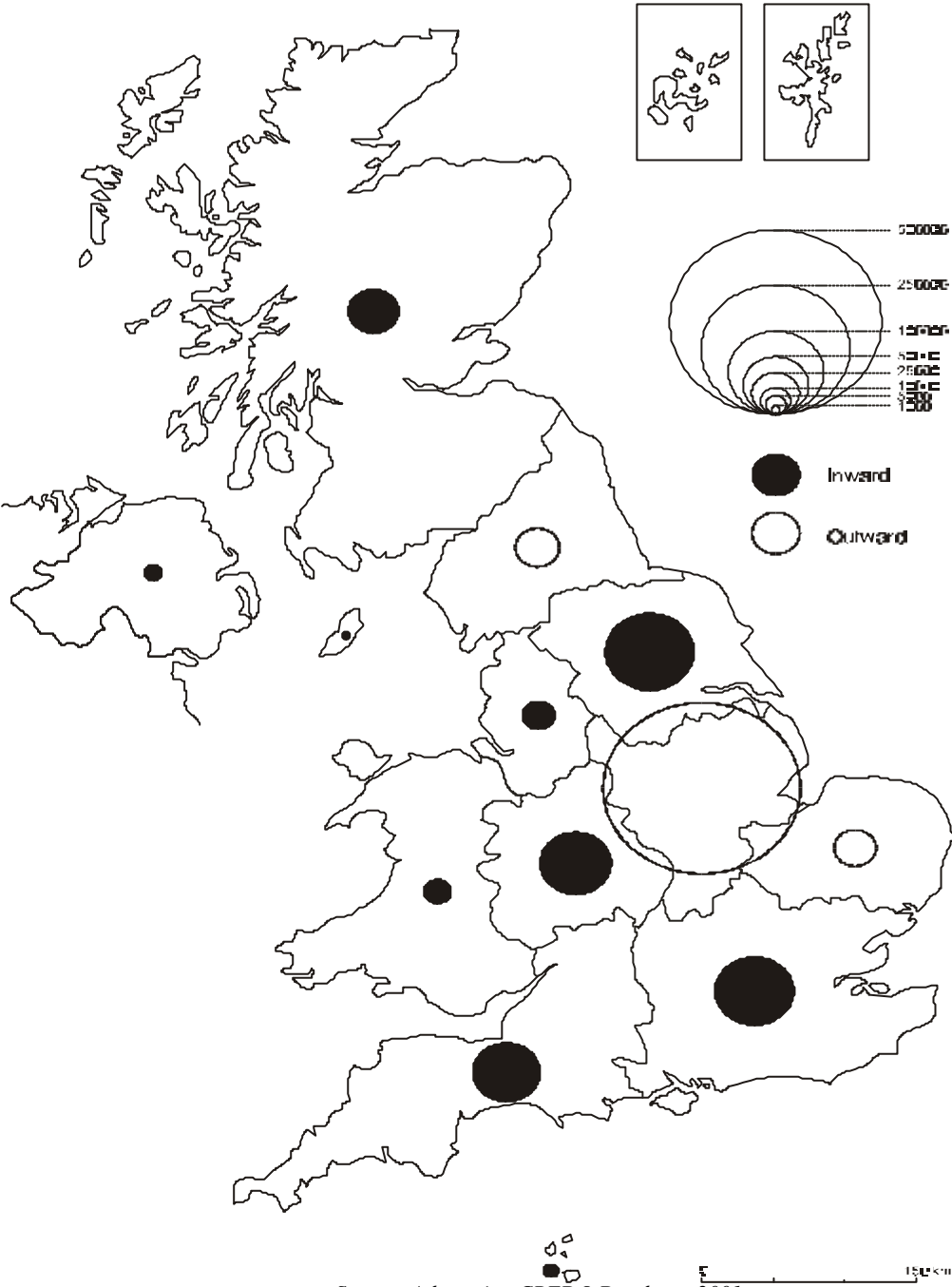

Finally, table 4 shows that moves within the region typically involve fewer jobs than moves out and moves into the Southeast on average are significantly larger than the other two types.

**Table 4: Firms, jobs and average jobs per move in the Southeast, 1988-1999**

	Firms	%	Jobs	%	Average jobs per move
Moves within	103,497	87	14,365,624	77	139
Moves out	9,403	8	2,110,747	11	224
Moves into	6,185	5	2,181,053	12	352
Total	119,085	100	18,657,424	100	

Source: Adaptation CREDO database, 2001.

### Sector pattern

Table 5 shows that financial and business service firms are the most mobile service sector businesses. However, while distribution and business service sector companies clearly account for the largest share of corporate relocations (28% and 22% respectively), these businesses have a relatively low propensity to move. In contrast, manufacturers tend to be more likely to relocate than service sectors companies.

**Table 5: Business movements by sector, 1988 to 1999**

	Business population*	Total movements**	% of total	Volatility***
Utilities	347	184	0.008	53.
Chemical and plastics	8,511	4,161	2	49
Financial services	28,080	10,388	5	37
Clothing and textiles	10,425	3,790	7	36
Engineering	51,065	18,222	8	36
Food and drink	5,174	1,664	0.07	32
Other manufacturing	38,744	11,767	5	30
Business services	202,226	56,903	22	28
Transport & communication	48,439	12,494	6	26
Construction	132,958	25,844	11	19
Distribution	342,416	63,964	28	19
Other services	188,255	10,453	5	6
Primary	73,849	2,541	1	3
Hotels and catering	102,660	2,657	1	3
Total	1,233,149	225,032	100	18

\* Dun and Bradstreet, December 1999.

\*\* Business moves between 1988 and 1999;

\*\*\* Total moves as a percentage of business population – measure of propensity to move.

Source: CREDO, Prism Research, 2000.

## 6.2 Firm migration in the Netherlands in 1986-1995

In this period the amount of firm migration in the Netherlands totals 493,000. Figure 9 and table 6 show that since the 1980s the mobility rate has been growing steadily: from 36,000 firms in 1987 to 68,000 firms in 1995. Proportionally, the growth of mobility in the periods 1990/'91, 1992/'93 and 1994/'95 is 11%, 7%, and 16.7% (Kemper and Pellenbarg). Moves as a percentage of all firms are up from 5% in 1986 to 8% in 1995.

The majority of moves are short distance; around 85 to 90%. Long distance migrations encompass around 10 to 15% of the total, but especially these types of migrations generate public attention and attention from the press. Migrant firms are mostly (very) small firms, which is demonstrated by the amount of jobs involved.

**Figure 9: Firm migration in the Netherlands, 1986-1995**

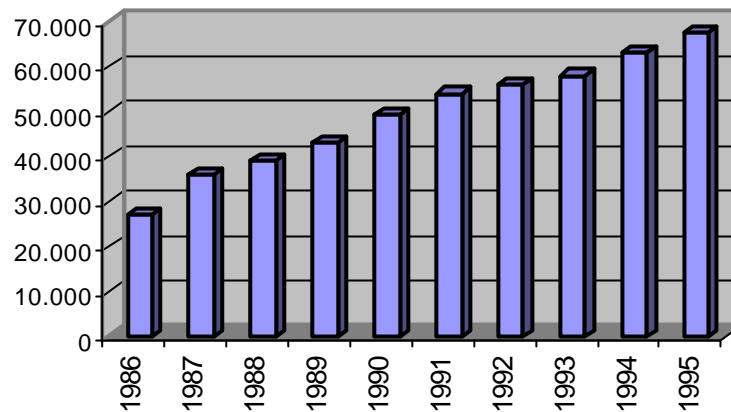

Source: Kemper and Pellenbarg (1986, 1988, 1991, 1993, 1995, 1997)

1994/1995 experiences a yearly total of around 180,000 jobs, indicating an average size of migrant firms of 2.8 employees. The 10 to 15% interprovincial migrations involve 17,000 transferred jobs, which connects with the size of short distance migrations. Table 6 presents an overview of the economic importance of migration in the Netherlands. We add the migration rate of the firm panel of our faculty, because it puts the results of the mutation balance in perspective. The firm panel is a representative sample of Dutch firms, which periodically receive a questionnaire related to firm demographic topics. In the panel, migration rates are only half of the rates recorded by the Mutation Balance, because the panel holds relatively few of the smallest, most mobile category of firms.

#### *Geographical pattern*

The publications of Kemper and Pellenbarg describe that the so-called intermediate provinces (adjacent provinces of the Randstad) of Noord-Brabant, Gelderland, and recently Flevoland are more and more involved in the Dutch spatial economic dynamics<sup>ix</sup>. The migration deficit of the Randstad has grown from a yearly average of 433 in 1992/93 to 517 in 1994/1995. The province of North Holland (with Amsterdam) experiences a growth in the migration deficit, while in the South Holland (with Rotterdam and The Hague) the deficit decreases.

The province of Utrecht, which presented a migration surplus in 1991, in 1995 became an expulsion region. Recently the most peripheral provinces of Groningen, Friesland, and Zeeland profit from the 'landing' of firms from especially the Randstad. In May 2001, it is the first time that Groningen receives more firms from the Randstad than it loses firms to other regions. Due to the scarcity of space and congestion in the economic core of the Netherlands and the more strict spatial (the green and red contours) and environmental planning (outplace 'hazardous' firm

and difficulties of mixing working and living), we predict that the peripheral regions will be more and more involved.

**Table 6: Firm migration in the period 1986-1995\***

Year	Mutation balance		Firm panel faculty	
	Amount of migrated firms	Migration rate	Amount of firms	Migration rate
1986	27,085	5.0	1,244	2.3
1987	36,036	6.1	1,266	2.6
1988	39,138	6.4	1,286	3.4
1989	43,008	6.7	1,309	3.4
1991	48,000	6.5	1,362	3.7
1991	54,000	7.5	1,362	3.7
1992	56,000	7.6	1,368	3.9
1993	58,000	7.4	1,380	3.3
1995	67,700	7.9	1,336	3.7

\* Because of a change in the registrations of the Mutation Balance of the Chambers of Commerce in 1993, the data in 1992 and 1993 are not directly comparable. A linkage can be made, using two notes for the year 1991; one measured note of 48,000 migrations with regard to the years before and a corrected note of 54,000 to realise a comparison with the years 1992 and 1993.

Source: Elaboration Ebels (1997, p. 37), Kemper en Pellenbarg (1997, p. 508) and Van Steen (1998, p. 27)

**Figure 10: Interprovincial firm migration '90-'91 and '94-'95**

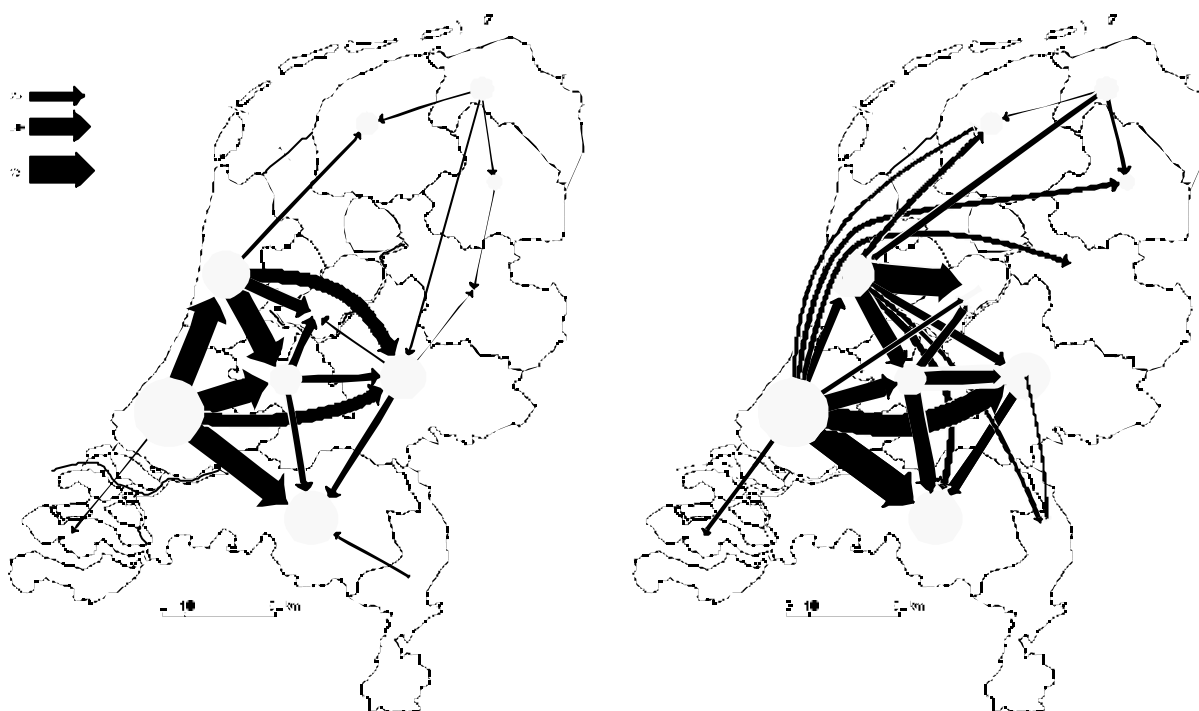

Source: Kemper and Pellenbarg, 1997, p. 19.

The figures 10 shows the interprovincial migration flows for industry, wholesale and commercial service for the periods 1990/1991 and 1994/1995. In the first period firms mostly move between the Randstad provinces. In 1994/1995, the migration flows between the Randstad and the adjacent provinces in the east and south of the country are clearly growing. Despite the recent growth in Groningen, the migration deficit increased from 120 in 1992/1993 to 180 in 1994/1995, which is caused by the emigration of commercial services. The recent improved position of Groningen may be caused by the attractiveness of the north for IT firms, which need

relatively low skilled labour (i.e. call centres). By contrast, the southern province of North Brabant experiences a growth in the migration surplus from 130 in 1992/1993 to 200 in 1994/1995. North Brabant is losing the image of the Dutch number one manufacturing province, because it mostly attracts wholesale and commercial service sectors. In addition, until recently North Brabant is regarded as an overflow region for South Holland, in 1994/1995 it registers more moves from the more central parts of the Netherlands. In terms of employment, North Brabant registers the biggest employment gains. In the province of Utrecht there still is a surplus, but it is decreasing. Gelderland shows a positive balance in 1994/1995.

### *Mobile sectors*

Table 7 shows that the most mobile sectors in 1994-1995 are the financial service sector (which belongs to the category 'others') with 16,000 moves, the wholesale and the commercial service sector. A comparison in time (1993-1995) shows that for all sectors together, industrial mobility rose from 7.4 per cent to 7.9 per cent. In particular, the wholesale and commercial service sector presents an annual percentage of mobile firms of around 10 percent. This indicates that in a recession period such as in 1992/1993, the basic economic sectors are less mobile with respect to non-basic sectors. On the other hand, in an economic growth period (1994/1995) the basic sectors are more mobile, while the non-basic sectors show fewer moves.

**Table 7: Firm mobility in the Netherlands in 1995**

Moving firms	Migration factor					
	Number 1994	Number 1995	growth % 1994-1995	Short distance	Long distance	total
Manufacturing	3,700	3,950	6.8	5.8	1.6	7.4
Building	3,620	4,250	17.4	6.6	1.1	7.7
Wholesale	9,300	9,800	5.4	7.4	2.7	10.1
Retail	6,280	6,550	4.3	3.6	0.6	4.2
Commercial services*	16,800	18,400	9.5	7.6	2.4	10.0
Personal services**	5,300	5,750	8.5	4.2	0.9	5.1
Other***	18,000	19,000	5.6	6.3	3.0	9.3
Total	63,000	67,700	7.5	5.9	1.9	7.9
Total 1993		58,000	pm	5.7	1.8	7.4
Total 1991		54,000	pm	5.5	1.8	7.3
Total 1989		43,000	pm	5.3	1.4	6.7
Total 1987		36,000	pm	4.9	1.2	6.1

\* Transportation, storage, communication, banking and insurance, business services.

\*\* Hotels/restaurants/bars, sports, recreation, house agents, laundry, hairdressing, beauty-centres

\*\*\* Mainly financial holdings

*Source: Kemper and Pellenburg, 1997*

There is a migration of manufacturing, wholesale and commercial service firms from the province of Utrecht to Gelderland and Flevoland. North Brabant only attracts wholesale and commercial service firms. Furthermore, Utrecht still receives firms from the North and South Holland. Manufacturing firms that leave the province of North Holland move to all other

provinces. Flevoland and Utrecht, and to a lesser degree also Gelderland and North Brabant attract wholesale and commercial service firms from North Holland. While in 1992/1993 manufacturing firms move to Flevoland, in 1994/1995 they are more inclined to move to Gelderland. North Brabant, Gelderland and Utrecht experience the largest amount of manufacturing firm immigration from South Holland. The attractiveness of the living climate plays an important role in the location of the service sectors that move from South Holland to the north eastern provinces of Overijssel and Drenthe.

### 5.3 Firm migration process: a comparison of two countries

This section presents a comparison of the phenomenon between the two countries and shows the problems associated with it. The literary overview on firm migration patterns in 1945-1970s, underlined that the policy controls, incentives and leading infrastructures have been a fundamental influence on industrial mobility in the United Kingdom (Townroe, 1983) as well as in the Netherlands. Moreover, manufacturing firm migration has slightly reduced interregional inequalities in incomes and employment opportunities. The most mobile sector was the manufacturing industry and the forces driving the relocation were mainly associated to lack of space, labour costs and transport related issues.

**Table 8: Firm migration process in the Netherlands and in the UK**

	United Kingdom ('99)	UK ('88-'99)	Netherlands ('95)	Netherlands ('86-'95)
Population	1,233,149**	pm	856,962***	pm
Firm migrations	39,897 (3,2%)	251,289	67,700 (7,9%)	493,000
Jobs	2,165,819	31,767,466	180,000	1,380,400*

\* This number is the result of multiplying the number of migrations with the average size of firms of 2.8.

\*\* Dun and Bradstreet, 1999.

\*\*\* Chamber of Commerce, 1997.

*Sources: Prism Research (2000) and Kemper and Pellenbarg (1997).*

The analysis of the most recent period shows the following results. The amount of firm migration in the UK in 1999 is about 39,897, which comprises 3,2% of the business population. In total 2,165,819 jobs are involved. In comparison, in 1995 the Netherlands registers a higher number of moves (67,700), equal to 8% of the business population, but fewer jobs are involved in the Netherlands (180,000) than in the United Kingdom. The largest number of firm movements in the Netherlands could be due to the fact that data of the Netherlands concern branch plants as well as head offices, while data on the UK only counts single location companies, head quarters and holding companies. In addition, the 'job migration' in the UK is not 'real'. Small firms are



under represented in the CREDO database because branches are not counted. This is one of the main difficulties to overcome in the comparison approach and one of the main goal of the future research.

In both countries (and in both periods) small companies comprise the highest percentage of moves that are mainly short distance movements. This aspect confirms the ‘dual-population hypothesis’ (Keeble, 1974): ‘smaller’ firms are characterised by short-distance migration out of the major conurbations and ‘larger’ firms by long-distance movements. However, the ‘long distance movements’ from the Northern Randstad to North Brabant and Limburg cannot be compared with the long distance migration of firms in the United Kingdom from the South East to Northern Ireland, Scotland or the North. Long distance migration in the Netherlands corresponds to ‘overspill’ in larger countries; in fact the Dutch national scale is to be compared to the south east in the UK. In the Netherlands and in the United Kingdom, the number of firm migrations is related to the economic conjuncture. Figure 4 shows that in a recession period, firms in the UK have a lower movement rate. On the other hand, the Netherlands (see fig.9) does not show a trough in that period, although the basic sector register less movements than the non-basic sector. The change in the registration of the Mutation Balance in 1993 could explain this discrepancy.

Finally, the most mobile sectors in both countries are the financial and business service sectors while in the 1970s the most mobile sector is the manufacturing industry. Figures 2 and 3 show the phenomenon of decentralisation from the core regions: the Randstad and the Southeast. Like most of the agglomerations in Western Europe, the Randstad’s largest centres and Greater London in the Southeast enters a process of urban decline during the 1970s and early 1980s. However, during the 1990s the downward trend has been checked and in some cases even been reversed (Bramezza and Van den Berg, 1992; Bramezza *et. al.* 1994; Atzema and Lambooy, 1999).

**Table 9: Industrial mobility in the UK (1988-99) and in the Netherlands (1986-95)**

SIC Group*	United Kingdom total moves '88-'99	Netherlands total moves '86-'95
Manufacturing	39,604	33,929
Building	25,844	28,930
Wholesale - Retail	63,964	125,450
Commercial services	79,785	171,105
Personal services	2,657	44,549
Other	10,453	81,720
Total	222,307	493,000

\* Standard Industrial Classification 92 adapted from the Dutch classification.

Source: Credo database and Kemper and Pellenbarg (1988, 1991, 1993, 1995, 1997)

One explanation of the reverse picture that the core region attracts firms instead of losing, may be explained by the focus on the office sector. We argue that in future the migration balance of the core areas will be more in balance because of the increased importance of office activities. An example of a practical explanation of deviating figures is the discussion between Kemper and Pellenburg and Atzema and Lambooy: *"Kemper and Pellenburg (1997) use the metaphor of the 'pressure cooker' to describe the migration of firms out of the Randstad. However, Atzema and Lambooy (1999) argue that the Randstad shows losses but also gains. They state that the Randstad improves its attraction of firms. The Union of Chambers of Commerce provides the data used in both analyses, but Atzema and Lambooy focus on firms with more than 5 employees, while Kemper and Pellenburg also entails smaller firms. The analysis led to different figures"*.

All the studies on firm migration in the Netherlands and in the United Kingdom (and also in international journals), which have been published in the past decades show that the main forces driving firm relocation are: lack of space, accessibility and labour market problems. The primary reason why firms relocate is the growth of their business. Unless forced to, firms move to change their premises. Relocation decisions are executed locally. Companies prefer to find a new location that is near their existing site, because they want to keep the existing workforce, though this appears to be less frequently achieved in practice. In fact, when choosing a location it is important to take into account the accommodation requirements of the employees, especially those who are highly qualified. Industry moves from locations near the town centres to sites on the boundaries of urban areas. Lack of space together with noise nuisance and environmental pollution stimulates industry relocation from the Randstad (see Utrecht as expulsion region) as well as from the South East (in particular the Greater London).

Infrastructure and accessibility are important location factors. The companies tend to locate in sites where they can easily get in contact with the existing customers. The British 'dominant segment' between the M4 and A1 provides the main example for business relocation out of the Southeast and underlines which location factors are perceived as important. In the Netherlands, the commercial services and logistics tend to locate near or in the urban area, or outside the urban area in a location along the highways, or near the main ports Schiphol and Rotterdam.

Non-material location factors such as the attractions of the city centre, better image of the building, and the commuting distance determine the relocation of offices.

While businesses leave the Greater London and/or the South East because of high costs of premises and labour, the city capital remains attractive for the financial and the commercial service sector and for its important public function. According to a study on the location preference of Dutch managers (Meester and Pellenburg, 1984, and Meester, 1999), in 1983, the core of the Randstad is considered as an optimal location. However, in the course of the years it lost its position as a consequence of the congestion problems, lack of space for expansion, and image problems. Enterprises in the service sector prefer a representative location in the city centre or along highways. Non-material factors provide added value to the service businesses. The more the office serves the general public the more likely the choice for a central location. In addition, offices rarely move very far mostly because their highly qualified employees are reluctant to leave their present accommodation, surroundings and social contacts (Van Noort and Reijmen, 1999). Finally, in the UK many companies did not decentralise head or regional offices from Central London but only 'back office' activities. Cheap labour market attracts low-value added type industries and the assisted areas represent a good alternative location.

As concerns government policy, in the Netherlands the government set up two policy measures to solve the main location problems: lack of space and road congestion. The first concerns the space for economic activity subsidies (REA) for improving and enlarging settlement opportunities on business areas, especially in the crowded Randstad and booming North Brabant. The second is the central government's policy to reinforce investment in infrastructure axes (i.e. ICES). However, the solution of space and accessibility problems becomes more and more expensive. Therefore, it is argued whether or not it is wise to continue the present concentration of economic activity in the Randstad at any price (Kemper and Pellenburg, 1997).

In the UK, the 1990s are for the most part dominated by less interventionist government policies. UK location policy must be seen within the context of EU policy, which supports the less favoured regions of Europe. EU structural funds are directed to Objective 1 areas – parts of Wales, Northern Ireland, Merseyside (Liverpool city area), Cornwall, and South Yorkshire- and to Objective 2 areas. These provide infrastructure, regeneration, education and training funds. In addition, throughout the 1980s and 1990s, there has been considerable devolution of the Government's central functions to the regions, mainly to the large cities of the provinces such as Cardiff, Sheffield, Leeds, Manchester, Glasgow, Newcastle, Liverpool but also to smaller towns, such as Telford,

Runcorn and Exeter. This flow has reduced in recent years as many of the departments have now been moved, leaving only core functions in London<sup>x</sup>.

## 8 Conclusion and future research questions

This paper shows that the change in the type of relocated firms relates to the reasons why they moved. In the 1970s (in both countries) the manufacturing industry is most mobile, while the last decades the service industry becomes the most 'mobile' sector. This is caused by the transformation of Western economies into information processing service and knowledge economies. Nowadays, business service firms are more inclined to relocate due to lower investments in their location and the information processing economy.

On one hand, more suitable premises and business expansion remain the main forces driving the relocation, but on the other hand, office related 'softer' factors such as the attractiveness of the building and the surroundings become more and more important. In addition, human capital nowadays has a primary role in the location decision of an enterprise. The cheaper labour cost, which was a pull factor for manufacturing industry loses its importance and cost reduction associated with regional policy financial incentives in for example the assisted areas appears to be a poor attraction on its own.

As the paper shows, the government policy should take into account current location factors and living conditions. This may be a chance for the more sparsely populated areas. For example, in the Netherlands people move to housing areas in the more peripheral regions of Drenthe and Overijssel and in the United Kingdom to Berkshire and Oxfordshire and in future maybe to Devon and Cornwall. Analysing firm migration is useful to develop effective spatial economic policy. One of the main goal of the future research of the authors of the paper is to get inside the government policies in both countries and test its results in firm relocation process.

Finally, Pen (2000) argues that the well-known lists of location factors are too superficial and more research has to be executed about the underlying motives and the decision-making process. As Prism Research (2001) points out, *"we need local, up to date research to tell us though, whether it is inadequate size, unsuitable image, lease terms, inefficient layout, lack of under floor cabling, air-conditioning etc. which is driving demand at a particular time and in a particular location"*. This quote neglects the underlying strategy of the firm and the organisational structure of the firm.

If these aspects are taken into consideration firm migration research will lead to more grounded motives instead of the current practice of repeating the same lists of location factors. This together with a comparative knowledge of firm migration process may mean that the twenty calm years will also end in a more theoretical sense.

---

<sup>i</sup> The employees are divided into categories (for example: 0,1,2-4, 5-9, 10-20, 20-50).

<sup>ii</sup> In, out and within moves.

<sup>iii</sup> Almost all companies and their branch establishments are required to register under the Trade Registration Act, which came into effect at the same time as the Chambers of Commerce Act (1921).

<sup>iv</sup> After the 1985 there were a registration each year and a table plus article every two years (Kemper and Pellenberg 1988, 1991, 1993, 1995, and 1997). The last report is dated 1997 and analyses firm migration for the years 1994/1995. Before 1985 the entry and exit list of each chamber had to be compared to trace relocating companies.

<sup>v</sup> The Chief Executive is Registrar of Companies in England and Wales. There is a separate registrar of Companies in Scotland. Companies House does not cover Northern Ireland.

<sup>vi</sup> Scotland, Northern Ireland, Wales, Northern and North Western England and parts of the South West and the Yorkshire and Humberside regions (Townroe, 1979).

<sup>vii</sup> The British industrial movement studies focused on the manufacturing sectors of industry, usually ignoring the smallest units and the short distance moves. These studies were set upon two databases: the 'Record of Movement' (ROM) and the 'Record of Opening and Closures' (ROC) (Townroe, 1983). Two forms of movement are objects of study: transfer and branch.

<sup>viii</sup> Thus, while 9,403 companies are observed to move out in the period 1988-99, 6,185 firms move in. In addition, around 2,110,747 jobs are 'transferred' out and 2,181,053 are transferred in (table 4).

<sup>ix</sup> The Randstad comprises the urbanised part of the three provinces of North-Holland, South-Holland and Utrecht that in turn include the four largest urban agglomerations: Amsterdam, Rotterdam, the Hague and Utrecht.

<sup>ix</sup> Interview to Mr. Hamby, Prism Research, 2001.

---

## Acknowledgements

We would like to thank: Prof. Gillepsie, Mr. Hamby, Prof. Hayther, Mr. Kemper, Prof. Lloyd, Prof. Pellenbarg and Prof. Van Wissen for their precious suggestions.

## References

Atzema O.A.L.C. and Lambooy J.G. (1999), Agglomeration economies and migration of firms, in: Van Dijk J. and Pellenbarg P.H. (eds), *Demography of firms*. Groningen:Netherlands Geographical Studies, p.123-140.

Bade F.J. (1983), Locational behaviour and mobility of firms in West Germany, *Urban Studies* 20, p.279-297.

Bramezza I. and van den Berg L. (1992), Randstad Holland: sviluppo e pianificazione di una metropoli complessivamente concorrenziale, in *La Padiania, una regione italiana in Europa*, ed. Giovanni Agnelli Foundation, Turin.

Bramezza I., van den Berg L. and van der Borg J. (1994), The competitive position of the Randstad in the 1990s, in Cheshire P. and Gordon I. Ed., (1995), *Territorial Competition in an Integrating Europe*, Avebury, p.48-64.

Cameron G.C. and Clark B.D. (1966), Industrial movement and regional problem, University of Glasgow Social and Economic Studies, *Occasional Paper No.5* Edinburgh: Oliver & Boyd.

Cheshire P. and Gordon I. Ed., (1995), *Territorial Competition in an Integrating Europe*, Avebury.

Daniels, P W, 1969, Office decentralization from London - policy and practice. In: *Regional Studies*, 3, pp. 171-179.

Dennis R.T. (1978), The decline of manufacturing employment in Greater London: 1966-74, *Urban Studies*, 15, p.63-73.

Ebels, H J, 1997, *Oudere stadsdelen en de ruimtelijke effecten van bedrijfsverplaatsingen; een toespitsing op de niet-consumentverzorgende sectoren in Amsterdam en Rotterdam*, Amsterdam (Faculteit der Ruimtelijke Wetenschappen)

---

Universiteit van Amsterdam).

Forthergill S. and Guy N. (1990), *Retreat from regions: corporate change and the closure of factories*, Jessica Kingsley Publishers and Regional Studies Association, London.

Fielding A. and Lloyd (1992?), *Migration and Business relocation: the case of the South East*, London: HMSO, referred to 1980s)

Fingleton and Tyler (1989), *A cost based approach to the modelling industrial movement in Great Britain*, *Regional Studies*, Vol.24.5, pp.433-445.

Hayter R. (1997), *The dynamics of industrial location. The factory, the firm and the production system*. New York: Wiley.

Hessels, M, 1992, *Locational dynamics of business services; an intrametropolitan study on the Randstad Holland*, Utrecht (Faculteit der Ruimtelijke Wetenschappen).

Johnston R J, 1991, *Geography and geographers: Anglo-American human geography since 1945*, London (Edward Arnold).

Keeble D. (1968), Industrial decentralisation and the metropolis: the north-west London case, *Transactions, Institute of British Geographers*, 44, p.1-54.

Keeble D. (1971), Employment mobility in Britain, in: Chisholm M. and Manners G. (eds), *Spatial policy problems of the British economy*. Cambridge: Cambridge University Press, p.24-68.

Keeble D. (1972), Industrial movement and regional development in the United Kingdom, *Town Planning Review* 43/1, p.3-25.

Keeble D. (1974), *The movement of firms*, Amsterdam: The Open University.

Keeble D. (1975), Industrial mobility; in which industries has plant location changed most? – a comment, *Regional Studies* 9/3, p.297-299.

---

Keeble D. (1976, 1978), *Industrial location and planning in the United Kingdom*, London: Methuen & Co.

Keeble, D, 1979, Industrial geography. In: *Progress in human geography*, 3, pp. 318-323.

Kemper N. J. and Pellenbarg P.H. (1997), *Industrial mobility in the Netherlands*, SOM Research Report, Groningen

Klaassen L.H. and Molle W.T.M., Ed., (1983), *Industrial Mobility and Migration in the European Community*, Gower, Rotterdam.

Kruyt B. (1979), The changing spatial pattern of firms in Amsterdam: empirical evidence. *Tijdschrift voor Economische en Sociale Geografie* 70-3, p.114-157.

Lloyd P E and Dicken P, 1992, *Location in space; theoretical perspectives in economic geography*, New York (Harper Collins).

Louw, E, 1996, *Kantoorgebouw en vestigingsplaats; een geografisch onderzoek naar de rol van huisvesting bij locatiebeslissingen van kantoorhoudende organisaties*, Delft (Delftse Universitaire pers).

Markusen, A, 1999, Fuzzy concepts, scanty evidence, policy distance: the case for rigour and policy relevance in critical regional studies. In: *Regional Studies*, 33, pp. 869-884.

McLaughlin, G E, S Robock, 1949, *Why industry moves south: a study of factors influencing the recent location of manufacturing plants in the south*, Kingsport, (National Planning Association, Kingsport press).

Meester, W J, 1999, *Subjectieve waardering van vestigingsplaatsen door ondernemers*, Groningen (Faculteit der Ruimtelijke Wetenschappen).

Molle W.T.M. (1977), Industrial mobility – A review of empirical studies and an analysis of the migration of industry from the city of Amsterdam, *Regional Studies*, vol.11, pp.323-335.

Molle W.T.M. (1983), The Netherlands, in Klaassen L.H. and Molle W.T.M., Ed., (1983), *Industrial Mobility and Migration in the European Community*, Gower, Rotterdam.



---

Moore B., Rhodes J. and Tyler P. (1986), *The effects of Government regional economic policy*, HMSO, London.

Van Noort E.A. and Reijmen I.J.T. (1999), *Location Choice of SMEs*, EIM, Zoetermeer.

Ortona G. and Santagata W. (1983), Industrial mobility in the Turin metropolitan area 1961-1977, *Urban Studies* 20, p.59-71.

Pellenbarg P.H. (1985), *Bedrijfsrelokatie en ruimtelijke cognitie* (Firm relocation and spatial cognition), Sociaal-geografische Reeks 33, FRW/RUG, Groningen (PhD thesis University of Groningen).

Pen C.J. (2000), *Actors, causes, and phases in the decision-making process of relocated firms in the Netherlands* paper presented at the RSA conference.

Pen C J and Pellenbarg P.H. (1998), *Firm migration and central government policy; an overview*, paper presented at the RSA conference.

Prism Research and Liverpool University (1992). *Migration and Business relocation: the case of the South East*, London: HMSO.

Prism Research (2001), *Land & Property Study – Bournemouth, Dorset & Poole Economic Partnership*, Telford.

Rossi A. and Filipini P. (1995), The mobility of establishments and territorial competition: the case of the Zurich metropolitan area, in Cheshire P. and Gordon I. Ed., (1995), *Territorial Competition in an Integrating Europe*, Avebury, p.156-178.

Sant M. (1975), *Industrial movement and regional development: the British case*, Oxford: Pergamon Press.

Scott, A J, 2000, Economic geography: the great half-century, in *Cambridge journal of economics*, 24, pp. 482-504.

SISWO (1967), *Verplaatsing industriële bedrijven*. Deelrapport 1,2 SISWO, Amsterdam.

---

Smith D.M. (1971), *Industrial location: an economic geographical analysis*, New York: Wiley.

Steen, P J M van, 1998, *Bedrijvenlandschap 2000+; bedrijfsverplaatsingen en de vraag naar bedrijfslocaties in Nederland*, Groningen (Faculteit der Ruimtelijke Wetenschappen).

Taylor J and Wren C. (1997), UK regional policy: an evaluation, *Regional Studies*, vol.319, pp.835-848)

Townroe, P M, 1971, *Industrial location decisions; a study in management behaviour*, Birmingham (Centre for urban and regional studies University of Birmingham).

Townroe P.M. (1972), Some behavioural considerations in the industrial location decision, *Regional Studies* 6, p.261-272.

Townroe P.M. (1973), The supply of mobile industry: a cross-sectional analysis, *Regional and Urban Economics* 2/4, p.371-386.

Townroe, P M, 1976, *Planning industrial location*, London (Leonrad Hill books).

Townroe P.M. (1979), *Industrial movement: experience in the US and the UK*, Westmead: saxon House.

Townroe, P M, 1991, Rationality in industrial location decisions. In: *Urban Studies*, 28, pp. 383-392.

Van Dijk J. and Pellenbarg P.H. (1999), Eds, *The Demography of firms: progress and problems in empirical research*, Groningen: Netherlands Geographical Studies, p.123-140.

Van Dijk and Pellenbarg (2000), 'Firm relocation decisions in the Netherlands: An ordered Logit approach', *Regional Science*, 79 (2), pp.191-219.

Van Dijk J., Pellenbarg P.H. and van Wissen L.J.G.(2001), *Firm Migration*, Paper forthcoming.

Wood, P A, 1978, Industrial organisation, location, and planning. In: *Regional Studies*, 12, pp. 143-152.

