

Ewerlin, Denise

**Article**

## The influence of global talent management on employer attractiveness: An experimental study

Zeitschrift für Personalforschung (ZfP)

**Provided in Cooperation with:**

Rainer Hampp Verlag

*Suggested Citation:* Ewerlin, Denise (2013) : The influence of global talent management on employer attractiveness: An experimental study, Zeitschrift für Personalforschung (ZfP), ISSN 1862-0000, Rainer Hampp Verlag, Mering, Vol. 27, Iss. 3, pp. 279-304, [https://doi.org/10.1688/1862-0000\\_ZfP\\_2013\\_03\\_Ewerlin](https://doi.org/10.1688/1862-0000_ZfP_2013_03_Ewerlin)

This Version is available at:

<https://hdl.handle.net/10419/113669>

**Standard-Nutzungsbedingungen:**

Die Dokumente auf EconStor dürfen zu eigenen wissenschaftlichen Zwecken und zum Privatgebrauch gespeichert und kopiert werden.

Sie dürfen die Dokumente nicht für öffentliche oder kommerzielle Zwecke vervielfältigen, öffentlich ausstellen, öffentlich zugänglich machen, vertreiben oder anderweitig nutzen.

Sofern die Verfasser die Dokumente unter Open-Content-Lizenzen (insbesondere CC-Lizenzen) zur Verfügung gestellt haben sollten, gelten abweichend von diesen Nutzungsbedingungen die in der dort genannten Lizenz gewährten Nutzungsrechte.

**Terms of use:**

*Documents in EconStor may be saved and copied for your personal and scholarly purposes.*

*You are not to copy documents for public or commercial purposes, to exhibit the documents publicly, to make them publicly available on the internet, or to distribute or otherwise use the documents in public.*

*If the documents have been made available under an Open Content Licence (especially Creative Commons Licences), you may exercise further usage rights as specified in the indicated licence.*

Denise Ewerlin\*

## **The influence of global talent management on employer attractiveness: An experimental study\*\***

Due to the intensifying “war for talent”, companies are increasingly looking to position themselves as attractive employers. They are also increasingly communicating their global talent management (GTM) programs through their websites and job advertisements. However, to date, there is a dearth of research as to whether the presence of GTM programs increase the attractiveness of companies for talent, and to what extent this effect is shaped by the contents of GTM programs and the cultural background of talented individuals. This paper seeks to overcome these deficits by presenting an experimental investigation of the influence of GTM programs on employer attractiveness and how this is moderated by culture. It shows that employer attractiveness is not influenced by GTM programs per se, but rather by the contents of GTM programs and the cultural background of talented individuals.

### **Der Einfluss des Global Talent Managements auf die Arbeitgeberattraktivität: Eine experimentelle Untersuchung**

Vor dem Hintergrund des sich stetig verstärkenden „War for Talent“ versuchen Unternehmen vermehrt, sich als attraktiver Arbeitgeber am Arbeitsmarkt zu positionieren. Im Zuge dessen lässt sich eine zunehmende Kommunikation des Global Talent Managements (GTM) in Internetauftritten und Stellengesuchen beobachten. Bislang ist jedoch weder hinreichend empirisch untersucht, inwiefern das Vorhandensein eines GTMs die Attraktivität von Unternehmen für Talente erhöht, noch inwieweit die Inhalte des GTMs und die kulturelle Prägung der Talente diesen Effekt beeinflussen. Der Aufsatz reduziert dieses Forschungsdefizit, indem mittels einer experimentellen Untersuchung der – durch Landeskultur moderierte – Einfluss des GTM auf die Attraktivität von Unternehmen untersucht wird. Es zeigt sich, dass GTM nicht pauschal die Arbeitgeberattraktivität erhöht, sondern dass diese Wirkung sowohl von den Inhalten als auch der kulturellen Prägung der Talente abhängt.

**Key words:** **global talent management, employer attractiveness, war for talent, person-organization fit, experimental research**  
(JEL: M00, M12, M50, M53, M54)

---

\* For correspondence: Denise Ewerlin, Chair of Business Administration, in particular Organization Studies and Human Resource Management, Faculty of Business Administration and Economics, Heinrich-Heine-University Duesseldorf, Universitaetsstraße 1, 40225 Düsseldorf, Germany. E-mail: Denise.Ewerlin@hhu.de.

\*\* Article received: January 2, 2013

Revised version accepted after double blind review: August 10, 2013.

## 1. Introduction

The war for talent has become a key challenge for multinational corporations in recent years. The reasons for this are diverse. Globalization and the associated intensification of competition have increased the demand for qualified human resources (Schuler, Jackson, & Tarique, 2011b, p. 17). Simultaneously, demographic changes and the increasing migration of high-skilled employees to foreign countries have led to a decrease in labor supply in western industrial countries (Baruch, Budhwar, & Khatri, 2007, p. 99). Moreover, due to the growing number of company relocations, emerging market countries are facing a rapidly increasing demand for talent that cannot be met due to the insufficient amount of available qualified manpower. Boosted by the increasing relevance of knowledge as a resource, qualified employees worldwide have become a key factor in the battle for competitive advantage (e. g. Greening, & Turban, 2000, pp. 254-255; Hoye, & Lievens, 2007, p. 2024; Beechler, & Woodward, 2009, pp. 275-276; Scullion, & Collings, 2011, p. 7-10). GTM as a encompassing concept of “all organizational activities for the purpose of attracting, selecting, developing, and retaining the best employees in the most strategic roles [...] on a global scale” (Scullion, & Collings, 2011, p. 6) has gained center stage for human resource management.

As a consequence of these developments, companies are increasingly trying to position themselves as attractive employers on the labor market (Schuler, Jackson, & Tarique, 2011a, p. 511). As part of this, the increased communication of GTM programs through websites and job advertisements, but also particularly in sustainability and personnel reports can be observed. This indicates that companies expect that improving the visibility of their GTM programs will increase their attractiveness as employers. The link between the introduction of human resource concepts and employer attractiveness is highlighted in several comparable studies. For example, the introduction of diversity management in companies has been shown to have a positive effect on employer attractiveness (Williams, & Bauer, 1994, p. 302; Thomas, & Wise, 1999, p. 386). Furthermore, Lievens, Decaestecker, Coetsier and Geirnaert (2001, p. 45) found a positive correlation between the person-organization fit (P-O fit) and employer attractiveness, as well as a cultural influence on the level of employer attractiveness. Therefore it can be hypothesized that GTM programs tailored to talented individuals has a positive influence on employer attractiveness.

To date, there is a dearth of empirical studies that analyze how GTM programs increases the employer attractiveness of companies for talent<sup>1</sup> or how far the content of GTM programs and the cultural background of talented individuals influence this effect. However, these questions are relevant for several reasons. First, due to the “war for talent”, in the future talent will be able to choose between many attractive job offers. Second, the design of GTM programs will play an important role in talented individuals’ choice of employer, due to the fact that the decisive factor in selecting an employer is the P-O fit rather than the job offer itself (Rynes, & Cable, 2003). Third, knowledge about the influence of the design of GTM programs on employer attractiveness would enable companies to communicate more effectively with talent.

---

<sup>1</sup> The terms “talent” and “talented individuals” are used interchangeably.

The closer is the fit between talented individuals' demands and GTM programs, the greater is the number and quality of applicants and the greater is talent commitment (Piansoongnern, Anurit, & Bunchapattanasakda, 2008, p. 73). Finally, it can be assumed that the influence of GTM programs is moderated by cultural effects. This is because of the influence of culture on talented individuals' needs (Gunkel, 2006, p. 105). It is possible that a globally designed talent management can trigger different effects on employer attractiveness in different cultures. To use these effects and thus to also ensure a cultural fit between talent and GTM programs, an exploration of cultural influences on employer attractiveness is necessary. Against this background, the aim of this paper is to analyze the influence of GTM programs on employer attractiveness as moderated by culture.

## 2. Conceptualization of talent and global talent management

In order to describe GTM, it is necessary to consider the definition of talent (Tansley, Harris, Stewart, & Turner, 2006, p. 2). There are numerous definitions of talent. A study conducted in 2010 showed that although 87% of the surveyed companies defined "talent", none of the definitions were identical (Iles, Chuai, & Preece, 2010, p. 180). Both in practice and in academia, *talent* is commonly defined as a compilation of individual characteristics, thus producing a very wide connotation of talent that gives few clues as to how talent can be identified. At the same time, talent is often used interchangeably with the terms "high performer" or "high potential". Despite this variety of definitions, two frequently named elements can be identified.

The first relates to the capabilities or potential of a person and is thus linked to the original meaning of the word talent (Ready, Hill, & Conger, 2008, p. 69; Grossman, 2004, p. 209). It is generally assumed that a special capability of a talented individual leads him/her to achieve better results than a person without this capability (Grossman, 2004, p. 209). Such capabilities can include leadership skills (Ready, Hill, & Conger, 2008, p. 69), creativity, innovativeness and/or the potential to increase performance (Winkler, 2009, p. 7). The second focuses on performance. It primarily concerns the current fulfillment of responsibilities on the basis of specialist competencies (Darrough, & Melumad, 1995, p. 69; Davis, Cutt, Flynn, Mowl, & Orme, 2007, p. 1). Taken together, one can define talent as employees who have an above-average performance potential based on their talent and perform their responsibilities (very) well. In addition, it is necessary for them to be willing and able progress further.

Against this background, GTM focuses on employees who have been identified as talent by their company. However, no common definition of *global talent management* exists (Scullion, Collings, & Caliguri, 2010, p. 106). Nevertheless almost all definitions of GTM encompass the task of identifying, selecting, deploying, developing and retaining talent internationally in order to secure the sustained competitive advantage of the company (Capelli, 2008, pp. 1-3; Scullion, & Collings, 2011, p. 6). To fulfill this task multinational companies construct various programs, which are implemented with numerous instruments. Although these are company-specific, it is still possible to identify instruments that are part of practically all GTM concepts (Hatsum, 2010, p. 124). These are normally well-known HR measures (Zheng, 2009, p. 485; Garavan, 2012, p. 2430) that are however more nuanced, connected with each other and linked

to company strategy. Four functions or phases of GTM are generally identified in the literature.

The first function concerns the acquisition and identification of talent either internally or externally. The aim is usually to build up an international talent pool that, when required, can be tapped into quickly, reliably and on a company-wide basis (Stahl, Björkman, Farndale, Morris, Paauwe, Stiles, Trevor, & Wright, 2007, p. 10). Talent can be acquired and identified using several methods. For example, companies can present themselves at university and career fairs in order to increase their profile among potential talent. Moreover, by communicating the contents of their GTM program, they can make (already identified) talent aware of the special measures available for talent in the company, thus increasing the likelihood that these talented individuals will apply to the company. The second function focuses on the deployment of talent. The aim is to assign a talent to a concrete task or a concrete position. This entails quantitative and qualitative aspects, as well as spatial and temporal ones (Ready, & Conger, 2007, p. 70; Huang, & Tansley, 2012, p. 3674). At the center of the third function is the (further) development of talent. Development requirements can be identified on the basis of performance and potential assessments. Such requirements may concern specialist know-how, social competence and self-competence. A further aspect of this function is long-term career planning for talent. This has become very relevant against the background of the increasing career ambitions of talented individuals (Tranks, Rynes, & Bretz, 2002, p. 334). The fourth function concerns talent retention, which includes retaining and motivating talented individuals. This function is important because companies incur costs and a loss of knowledge through talent fluctuation.

### **3. Theoretical background and hypothesis development**

#### ***3.1 GTM program as a signal of an increase in employer attractiveness***

Due to the continuing shortage of specialist and managerial labor, it is becoming increasingly important for companies to position themselves as attractive employers in the eyes of job seekers (Lievens et al., 2001, p. 31). As job seekers only have limited knowledge of the companies, companies can influence the decisions of applicants by sending certain signals. This argument can be grounded in signaling theory, a theory that has become increasingly important in management research in recent years (e. g. Highhouse, Thornbury, & Little, 2007; Connelly, Certo, Ireland, & Reutzel, 2011; Martin, & Groen-in-'t-Woud, 2011). The theory provides a basis for analyzing the behavior of two parties who have access to different information (Spence, 1973, p. 356; Connelly et al., 2011, p. 39). The aim is to reduce information asymmetries between the parties by sending out signals. Such signals could for example be in the form of company-specific or job-specific information. The focus of signaling theory is on the credibility of these signals. Credibility is determined primarily through the receiver's interpretation of the signals (Martin, & Groen-in-'t-Woud, 2011, p. 88).

Particularly in the context of GTM it is important for companies to send out signals that are perceived positively by talent. Due to the increasing shortage of qualified employees, talented individuals can choose from a growing number of attractive job opportunities. This in turn is leading to an increase in uncertainty among talented in-

dividuals in their choice of company. Targeted signals are therefore necessary in order to influence the job applications of talented individuals. However, the challenges for companies are increasing because of the awareness among talented individuals of their value for companies. Companies thus need to react to the expectations of talented individuals in order to send effective signals. Studies have shown that in the choice of employer, company-specific factors are more crucial than job-related factors (Rynes, & Cable, 2003). In this respect, alongside company culture and sector(s) in which the company operates, GTM programs play an important role. The presence of GTM programs signal to talented individuals a special status within the company. The anticipated attention devoted to the needs of talent in turn increases employer attractiveness (Yaqub, & Khan, 2011, pp. 61-62). It can therefore be assumed that the presence of GTM programs will be seen by talent as a positive signal and will thus increase the employer attractiveness of the company.

Hypothesis 1: Companies with GTM programs are more attractive as employers than companies without GTM programs.

### ***3.2 The relevance of the person-organization fit and the influence of the individualism-collectivism dimension in the context of GTM***

It cannot be assumed however that GTM programs have an effect on employer attractiveness regardless of its content. Due to divergent needs on the part of talent, different GTM program contents lead to different levels of employer attractiveness. This can be justified on the basis of P-O fit. This describes the fit between a person and a company. The important question here is whether a job seeker finds a company more attractive to which he/she perceives a greater fit. This question has been the subject of numerous studies (e. g. Chatman, 1991, pp. 460-462; Kristof, 1996; Ng, & Burke, 2005, pp. 1197-1199; Hu, Su, & Chen, 2007, pp. 2512-2514). For example Schneider, Smith, Taylor and Fleenor (1998) found that individuals are attracted to companies with different intensities depending on their interests, needs, preferences and personality. The fit between person and organization can operate at different levels.

Two main aspects of fit can be found in the literature. The first concerns the supplementary fit, i.e. the alignment of the characteristics and attributes of a person with those of a company (Kristof, 1996, p. 2). This includes examining for example the congruence between the values, aims and/or norms of the individual and the organization (e. g. Chatman, 1991; Cable, & Judge, 1996; Kristof, 1996). The second relates to the complementary fit. One element of this fit concerns characteristics possessed by an individual that are lacking or needed in the company (demand-ability fit). A further element of the complementary fit is the fit between the needs of the individual and the company's offer (need-supply fit) (Kristof, 1996, p. 2). In the context of GTM, the adaptation of measures to the needs of talented individuals plays a crucial role. The P-O fit will therefore be investigated in terms of the need-supply fit in this paper.

Despite the strong influence of individual factors on the needs of talented individuals, there is a dearth of research on them (McDonnell, 2011, p. 172). Yet they play a key role in the context of GTM because it is only by fulfilling needs that the aims of GTM can be achieved. Although it is impossible to meet all the needs of talented in-



dividuals because of the individual nature of needs, it is vital in the international context of GTM to consider cultural differences in the needs of talent.

In an international context, the needs of talented individuals are not only influenced by individual preferences and personality, but also by the culture of the individuals. It can therefore be assumed that the instruments used by companies lead to different levels of employer attractiveness depending on the cultural background of talented individuals, thus making it sensible to offer different GTM instruments in different countries. Many studies have highlighted the need to offer culturally specific HRM instruments (Adler, & Jelinek, 1990; Bernardin, & Russell, 1993; Ramamoorthy, Gupta, Sardesai, & Flood, 2005). For example, Ramamoorthy and Carroll's (1998) study shows that a fit between HRM instruments and the cultural background of employees influences the effectiveness of the instruments.

A comprehensive analysis of the influence of different GTM contents is therefore only possible when the cultural background of talented individuals is included. In this paper, the constructs of individualism and collectivism are drawn on in order to consider cultural background. These constructs are chosen because they are the most widely researched cultural dimension (Sondergaard, 1994; Hofstede, 2001; Parkes, Bochner, & Schneider, 2001; Fiske, 2002; Oyserman, Coon, & Kammelmeyer, 2002) and the most important dimension in the working environment (Oyserman, Coon, & Kammelmeyer, 2002; Shulruf, Hattie, & Dixon, 2011, p. 52). In contrast to the other cultural dimensions of power distance, masculinity/femininity, uncertainly avoidance and long-term/short-term orientation, many studies have shown that individualism and collectivism "encourage and endorse different human resource management practices" (Ramamoorthy, & Carroll, 1998, p. 571; see also Adler, & Jelinek, 1990; Gomez-Mejina, & Welbourne 1991). These practices are part of this study because GTM programs combine these conventional practices in a special way to target talented people. Moreover, this dimension focuses on the relation of the individual to the group, a relation that is highly relevant in the context of GTM because of the special status of talent in the company. Simultaneously the most salient feature of individualism is valuing personal independence, which includes for example uniqueness and competitiveness. Collectivism is associated with a strong sense of duty to group, relatedness to others, seeking others' advice, harmony, and working with the group (Shulruf, Hattie, & Dixon, 2011, p. 52). These features are very important for the assessment of GTM instruments and programs, because on the one hand individuals are the focus, while on the other working the group is essential for talented people.

Collectivism and individualism are culturally-dependent psychological constructs that are used to identify people that are differentially influenced by culture in different countries (Shulruf, Hattie, & Dixon, 2011, p. 51). Individualistic and collectivistic cultures can be distinguished in terms of the extent to which interests and needs of individuals are put before the interests of a group (Hofstede, 1991; Triandis, 1995). The constructs can be used to classify both individuals and cultures. Hofstede (1991) assumed that individualism and collectivism is one-dimensional, bipolar variable in his research. However, several more recent investigations have shown that particularly on an individual level, individualism and collectivism is a multi-dimensional construct (e. g. Triandis, Bontempo, Villeral, Asai, & Lucca, 1988; Singelis, 1994; Ramamoorthy, &

Carroll, 1998, p. 572; Triandis, & Gelfand, 1998). On the basis of these findings, individualism and collectivism will be treated in this paper as a multidimensional variable that relates to the individual level of talent.

Individualistic people<sup>2</sup> can be ascribed a high level of autonomy. Their behavior is focused on themselves, independently of their network. Individualistic people put their own needs before those of others and only regard themselves to be a member of a group when it helps them to achieve their own goals and meet their own needs (Wagner, 1995). In contrast, the behavior of collectivistic people is oriented towards the interests of their network and the well-being of everyone is put before individual interests (Parkes, Bochner, & Schneider, 2001). There are thus large differences between individualistic and collectivistic people both in terms of their self-conception and the perception of their surroundings. Thus cultural background shapes the thought structures, behavior and values of individuals (Ramamoorthy et al., 2005, p. 754).

This implies both that there are differences in individuals' needs and that strongly individualistic people attribute more importance to their individual needs (Triandis, Brislin, & Hui, 1988, p. 269). In turn, these differences have implications for the demands placed on GTM programs. As a consequence of the differences between talented individuals in terms of the demands they place on GTM and the reactions they have to different GTM contents, it can be assumed that "[t]o the extent various HRM practices differ in encouraging individual interests and competitive behaviour, it is logical to expect that differences in individualism-collectivism orientations should be related to reactions to various HRM practices" (Ramamoorthy, & Carroll, 1998, p. 573). Starting points for differentiation in terms of contents are the aforementioned functions of GTM programs. Instruments to attract talent are primarily tailored to individual talent in the short-term and the assignment of talent is aligned to coordination and thus only operates at organizational level. In comparison, the functions development and retention offer various possibilities to increase employer attractiveness through the external communication of individual instruments. This paper will thus focus on the following orientations of GTM programs: career-oriented, compensation-oriented and work-organization oriented instruments.

In relation to talent development, career development instruments play a key role both for companies and talented individuals. Talented individuals normally pay more attention than do other employees to their career and the possibilities to develop their careers long term (Tranks, Rynes, & Bretz, 2002, p. 334). This relationship does not apply equally to individualistic and collectivistic talent. There are differences in the basis on which expectations of individuals' careers are formed. Individualistic people base their career expectations on their own performance (Ramamoorthy, & Carroll, 1998, p. 577) and thus assume that they will be promoted quicker if they perform well.

---

<sup>2</sup> In the paper, the term "individualistic people" is used to refer to individuals who have a high individualism score. Similarly, the term "collectivistic people" refers to people who have a high collectivism score. As the individualism-collectivism dimension is treated in the paper as a multidimensional variable, individuals have separate scores for individualism and collectivism.



Moreover, the orientation towards competitiveness and the sense of being unique among individualistic people increases the importance of career advancement as an individual goal (Triandis, Brislin, & Hui, 1988; Shulruf, Hattie, & Dixon, 2007, p. 394). Collectivistic people tend to regard advancement in a company more as a consequence of seniority (Ramamoorthy, & Carroll, 1998, p. 577), thus going against special career development in the context of GTM. GTM which identifies talent in relation to their capabilities and performance (see chapter 2) sends just signals of a performance-based development of the talented individuals. Hence the individualism value of the individual is relevant when appraising the career-oriented GTM program. The signals from the career-oriented GTM program are greater for individuals with a high individualism value than for individuals with a low value. Therefore the more individualistic is a person, the greater is the employer attractiveness of companies with a career-oriented GTM program. As seniority-based promotion goes against the key aim of GTM to promote employees with high potential, the collectivism value of a person has no moderating effect on the influence of career-oriented GTM programs on employer attractiveness. Due to the importance of career development for individualistic people, the following hypothesis can be formulated:

Hypothesis 2: The influence of a career-oriented GTM program on employer attractiveness is moderated by individualism. The more individualistic is a person, the greater is the employer attractiveness of companies with a career-oriented GTM program compared to companies without a GTM program.

Compensation-oriented instruments are important both for the attraction and retention of talent. Here, it is less salary level than the basis for salary calculation that is influenced by individualism and collectivism. Studies show that individualistic people prefer individual and performance-based pay (Ramamoorthy, & Carroll, 1998, p. 574; Tranks, Rynes, & Breetz, 2002, p. 334; Milkovich, Newman, & Gerhart, 2011). Moreover, Triandis, Brislin and Hui (1988, p. 269) found that individualistic people placed more importance on pay than on the network in which they operated. In contrast, collectivism is linked to a greater desire for pay based on group performance because this encourages equality and harmony within the group (Ramamoorthy, & Carroll, 1998, pp. 574-357). Moreover, there is evidence that collectivistic people are more satisfied with a lower salary where it serves the well-being of the group (Hui, Yee, & Eastman, 1995). It can therefore be assumed that salary is of secondary importance for collectivistic people. Therefore it can be argued that the collectivism value of a person does not have a strong effect on the influence of compensation-oriented GTM programs on employer attractiveness, because companies regularly offer individualistic compensation to employees in GTM programs. In contrast, the individualistic orientation of a person is highly relevant. This compensation can be performance-oriented or tailored to individual needs. Compensation based on group performance and therefore compensation which would be a positive signal for collectivistic people is not possible within a GTM program because companies utilize compensation to retain talented individuals. Thus it can be assumed that the individualistic value has a moderating effect on the influence of compensation-oriented GTM programs on employer attractive-

ness. This GTM program is perceived as a positive signal for people with high individualism scores therefore has a positive influence on employer attractiveness.

Hypothesis 3: The influence of a compensation-oriented GTM program on employer attractiveness is moderated by individualism. The more individualistic is a person, the greater is the employer attractiveness of companies with a compensation-oriented GTM program compared to companies without a GTM program.

Alongside compensation and career development, work-organization oriented instruments are also important for talent retention. Such instruments include for example working time flexibility, the distribution of responsibilities within a team or the communication and transfer of information between employees. In order to retain talent, instruments such as working time arrangements that improve work-life balance and distribution of responsibilities in the sense of team-orientation can be used. The increasing flexibility of working time, for example through home-office days or flexi-time arrangements, contradicts the high career-orientation of individualistic people. Numerous studies have shown that the utilization of work-life-balance programs, for example the use of home-office days, is negatively related to perceived career and compensation development. Being in the same place as co-workers, supervisors, and mentors makes it easier to be part of the informal political network which is necessary for career advancement (Hill, Ferris, & Martinson, 2003, p. 224; see also Kurland, & Bailey, 1999). At the same time participating in work-life balance programs has a negative effect on the visibility of employees within organizations (Bailyn, 1993) which is related to negative career consequences (Darcy et al 2012, pp. 114-115). Therefore career anxieties of individualistic people are created through spending less time in the office and being passed over for a promotion (Judiesch, & Lyness, 1999). Therefore, in contrast to people with a lower individualistic score, greater flexibility of working time through a work-organization oriented GTM program is not likely to increase employer attractiveness for individualistic people, because of their high career ambitions. Similarly, for an individualistic person, a strong team-orientation is likely to lead to uncertainty in the group and in the long run to a decrease in the satisfaction of the individual (Ramamoorthy, & Carroll, 1998, p. 573). In contrast, collectivistic people tend to prefer a reduction in the boundaries between work and private life (Smith, Dugan, & Trompenaars, 1996). Colleagues are regarded as members of a network. Networks play a very important role for collectivistic people. The possibility of weakening the boundaries between work and private networks through work-life balance instruments can lead to increased satisfaction and in the long term to increased employer attractiveness. Moreover, the possibility of working in a stable team leads to higher satisfaction among collectivistic people because of their strong network orientation (Suh, Diener, Oishi, & Triandis, 1998; Parkes, Borchert, & Schneider, 2001). A work-organization oriented GTM program which has the task of retaining talented people in the organization focuses on working time flexibility and the distribution of responsibilities within teams. While these characteristics are counter to the preferences of individualistic people, they are positively related to the preferences of collectivistic people. Based on the positive influence of work-organization oriented instruments on

collectivistic talented individuals and the negative influence on individualistic talented individuals the following hypotheses can be formulated:

Hypothesis 4a: The influence of a work-organization oriented GTM program on employer attractiveness is moderated by collectivism. The more collectivistic is a person, the greater is the employer attractiveness of companies with a work-organization oriented GTM program compared to companies without a GTM program.

Hypothesis 4b: The influence of a work-organization oriented GTM program on employer attractiveness is moderated by individualism. The less individualistic is a person, the higher is the employer attractiveness of companies with a work-organization oriented GTM program compared to companies without a GTM program.

In order to investigate the relationship between GTM programs and employer attractiveness, it is crucial to consider the fit between the talented individual and the GTM program offered, and thus to consider the P-O fit. The influence of the P-O fit on employer attractiveness has already been highlighted by several studies (e. g. Cable, & Judge, 1996; Lievens et al., 2001; Hu, Su, & Chen, 2007). The question therefore is whether the P-O fit is also a decisive factor in increasing employer attractiveness in the context of GTM. It can be assumed that without a fit between the GTM instruments offered and the requirements that a talented individual has on GTM, positive effects on employer attractiveness cannot be expected. GTM programs thus only have an indirect effect on employer attractiveness because the signals that a company sends out are initially used by the job seeker to compare his/her needs with the instruments offered. It is only in a second step and on the basis of this comparison that they lead to perceived employer attractiveness. Thus, the following hypothesis can be formulated:

Hypothesis 5: The influence of GTM programs with a content-related focus<sup>3</sup> on employer attractiveness is mediated by the subjectively perceived P-O fit.

Figure 1 depicts the hypotheses in graphical form. In the model, the signals that a company sends out in the form of GTM programs have a positive effect on its attractiveness as an employer (hypothesis 1). This effect varies depending on the GTM orientation and is moderated by the degree of individualism and collectivism of individuals (hypotheses 2-4). However, at a deeper level of analysis, it can be assumed that GTM programs only have an indirect effect on employer attractiveness. The effect is mediated through the subjectively perceived P-O fit of a talented individual as this individual uses the GTM signals to compare these with his own needs and his resulting demands (hypothesis 5).

---

<sup>3</sup> GTM programs with a content-related focus include work-organization oriented GTM programs, career-oriented GTM programs, and compensation-oriented GTM programs.

**Figure 1: Overview of the hypotheses**

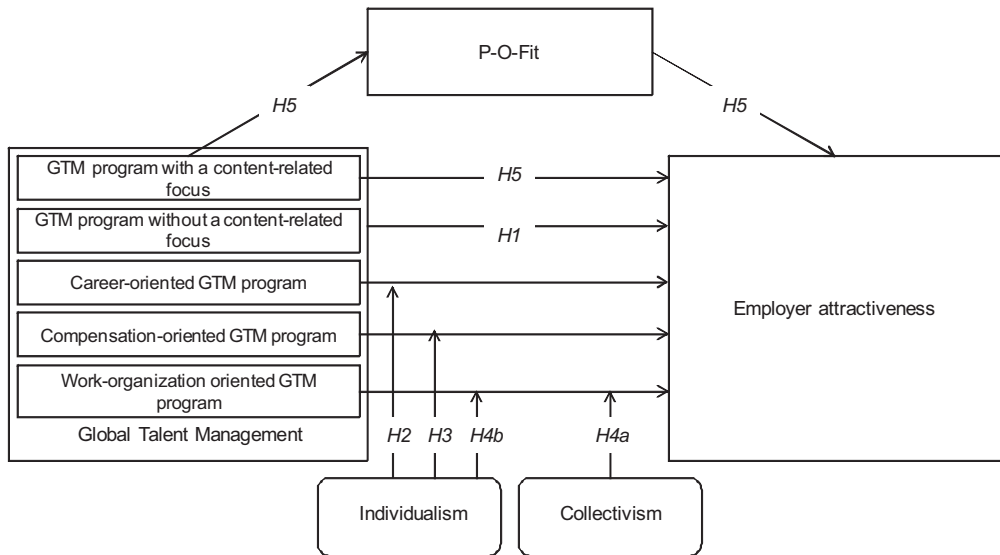

## 4. Research design

### 4.1 Participants and procedure

In order to study the influence of GTM programs on employer attractiveness, data were collected in autumn 2012 through an online survey. The survey was designed for students on business studies masters programs at universities in Germany and Great Britain. The students were informed of the survey and provided with the link to the survey either via mail from a lecturer at their university or through social networks. All participants were born in the respective country, had lived for no longer than one year in another country and were only familiar with the culture of their respective country of origin. A total of 217 students took part in the survey, of whom 130 were from Germany and 87 from Great Britain. Fifty-eight percent were female and this is representative of the proportion of female students in business studies programs in the two countries. The participants were on average 25.8 years old. The students had an average of 22.7 months work experience. Seventy-six point five percent of the students stated that they would be applying for jobs within the next year and would therefore enter the labor market as potential talent. This information is summarized in Table 1.

**Table 1: Descriptive data of the sample**

	Gender		Age		Work experience		Job applicant	
	m	w	M	SD	M	SD	Yes	No
Participants	91	126	25.8	4.39	22.7	30.74	166	51

Note: Work experience was measured in months; future job seeking was limited to a year. ; N = 217

A quantitative study was carried out in order to test the hypotheses. An experimental questionnaire design is suitable to study the influence of the independent variable GTM on the dependent variable employer attractiveness. The survey was structured in the form of a between-subject design. The survey thus consisted of a scenario that varied in relation to the different GTM program contents and a questionnaire that was identical for all participants. This contained questions relating to the dependent and moderating variables as well as questions regarding demographic data. The scenario-based design was operationalized by putting the participants in the situation of a job seeker who saw the following description of a company at their university:

On the notice board in your university you see this advertisement:

“The Company is an international conglomerate with multiple global businesses operating in various manufacturing and service sectors. In our company, 70.000 employees work with passion and expertise to develop solutions for sustainable progress. Their skills and commitment are the basis of our success. Hence we are always looking for motivated employees”. You remember that a former fellow student of yours has been working for a couple of months for this company and you call him to get further information. Your student is glad about your call and he is pleased to tell you about his experience. He says that he is very comfortable with the multifaceted duties that have been assigned to him. Also most of the supervisors are very friendly. But sometimes the size of the company makes it difficult for him to find his way around the various divisions.

The information was purposely formulated in general terms in order to avoid any association with a real company. Following the general description of the company, which represents the control version, that all participants received, the company's GTM program was described. The experimental conditions were varied between the four different GTM orientations. In one scenario, the GTM program had no focus with regards content.

Especially the possibility of being selected for the GTM program excites him. To get into this program the past attainment and the potential of the employee are rated annually. While just a few employees manage to get selected, he hopes be one of them because the small circle of talented individuals selected enjoys a high reputation in the company and a lot of other benefits.

The remaining three scenarios were added to this description and varied between (1) a career-oriented, (2) a compensation-oriented and (3) a work-organization oriented GTM program.

(1) The company attaches particular importance to the career of the identified talent. For this reason within the framework of GTM there are for example numerous training courses and individualized career support accessible to talent.

(2) The company attaches particular importance to a performance-oriented and above-average compensation of the identified talents. For this reason within the framework of GTM numerous compensation models are offered to talent.

(3) The company attaches particular importance to work-life balance of the identified talents and a high degree of team orientation within the GTM program. For this reason within the framework of GTM flexible working arrangements are offered to talent. Moreover the identified talents are embedded in a team, where they can work and make decisions together.

The control version contained no references to the presence of a GTM program. The participants were distributed to the four scenarios and the control version independently of time and place of participation. Therefore, participants and scenarios were assigned randomly. To control the randomization, a Kruskal Wallis test was conducted (Kruskal, & Wallis, 1952; Montgomery, 2012) which shows differences in the distribution of samples. As the test shows no significant differences for the relevant demographic variables, it can be assumed that the groups were randomly distributed and are comparable.

The survey was translated into the respective country language in order to avoid language differences in the answering behavior of participants. In order to ensure the translation equivalence of the survey from the original language English into German and in order to check the accuracy of the translation, the survey was translated back into English by a native speaker (Brislin, 1980; Brislin, 1986; Mullen, 1995; Hair, Black, Babin, Tatham, & Anderson, 2006).

#### **4.2 Measures**

Following the scenario, the dependent variable employer attractiveness was measured. This was done using Highhouse, Lievens und Sinar's (2003) scale. The five items ("This company is attractive to me as a place for employment", "For me, this company would be a good place to work", "I would not be interested in this company except as a last resort", "I am interested in learning more about this company", "A job at this company is very appealing to me"), all relating to general attractiveness (Cronbach's  $\alpha = 0.884$ ) were measured on a five-point likert scale (1 = "strongly disagree" to 5 = "strongly agree").

The dimensions individualism and collectivism were measured on the basis of the scale used by Shulruf, Hattie und Dixon (2007) and Shulruf (2008). The 26-item "Auckland Individualism-Collectivism Scale" (AICS) is based on the meta-analysis by Oyersmann, Coon und Kemmelmeier (2002) and consists of a scale each to measure individualism and collectivism. The individualism scale consists of 15 items and is divided into three sub-scales: competitiveness, uniqueness and responsibility. The collectivism scale consists of 11 items and two sub-scales: advice and harmony. All of the items were measured using a five-point likert scale (1 = "never or almost never" to 5 = "always or almost always") and measure individualism and collectivism on an individual level. Higher values therefore indicate a higher level of individualism and collectivism. The validity and reliability of AICS has been confirmed in various different cultures (Shulruf, Hattie, & Dixon, 2007), with a consistent factor structure and good internal consistency among the scales (Bernardo, 2010, p. 946). The reliability of the scales in this study is good for individualism (Cronbach's  $\alpha = 0.811$ ) and acceptable for collectivism (Cronbach's  $\alpha = 0.767$ ).

The P-O fit was then measured on the basis of Saks and Asforth's (1997) scale. The three items focus on the need-supply fit and were adapted linguistically to GTM, "This GTM is a good match for me", "This global talent management fulfills my needs" and "This global talent management measures up to the kind of treatment I am seeking". Reliability for this study was excellent (Cronbach's  $\alpha = 0.906$ ).



In order to test perception of manipulation within the scenarios (Sigall, & Mills, 1998) four items relating to GTM program orientation were measured. The participants were asked to what extent they agreed with the statements “The GTM attaches importance to career oriented measures”, “The GTM attaches importance to work-life balance and team-oriented measures”, “The GTM attaches importance to compensation-oriented measures” und “The GTM has no focus of content” (1 = “strongly disagree” to 5 = “strongly agree”).

The participants were also asked to estimate their job market prospects using a five-point likert scale (1 = “very bad” to 5 = “very good”). Other studies show that this variable is a relevant factor in the appraisal of employer attractiveness (Cable, & Judge, 1996, 297-298). Therefore it can be argued that talented individuals who perceive their job markets prospects to be favorable place higher demands on prospective employees which has consequences for their appraisal of employer attractiveness.

Following Bart (2001), the credibility of the described contents of the company was tested using a single item (“I think the described content is implemented in the company”) on a five-point likert scale (1 = “strongly disagree” to 5 = “strongly agree”).

Finally, demographic data were collected. These included gender as a dichotomous variable, age measured in years and cultural aspects. The participants were asked to state their place of birth and their cultural background including long stays abroad. Moreover, variables such as work experience were collected in order to gain an indication of the talent of participants.

### **4.3 Results**

A variance analysis was carried out in order to test the manipulation within the scenarios. This showed a significant relationship between the scenarios and the answers given to the manipulation check (GTM program without a content-related focus  $F(3.167) = 2.795$ ,  $p < .05$ ; career-oriented GTM program  $F(4.167) = 2.983$ ,  $p < .05$ ; compensation-oriented GTM program  $F(3.167) = 7.678$ ,  $p < .001$ ; work-organization oriented GTM program  $F(3.167) = 29.201$ ,  $p < .001$ ). It can thus be assumed that the participants comprehended the variation in the independent variable within the scenarios.

The means, standard deviations and correlations of the relevant variables in this study are shown in Table 2. As can be seen in the table, gender correlates weakly ( $r = .120$ ;  $p < .10$ ) with employer attractiveness. As expected in section 3.2 there is a strong correlation between P-O fit and employer attractiveness ( $r = .582$ ;  $p < .001$ ). Participants who said that they perceived a higher fit between GTM instruments and their own needs, also perceived a higher level of employer attractiveness. The relationship between credibility and employer attractiveness is also highly significant ( $r = .366$ ;  $p < .001$ ), so that as argued by signaling theory, credibility can be regarded as a key factor in assessing employer attractiveness. Moreover, there is a significantly positive relationship between the variation of the GTM program scenarios and employer attractiveness ( $r = .176$ ;  $p < .01$ ). It can thus be assumed that variation in GTM programs has an influence on employer attractiveness. The highly significant correlation between individualism and country ( $r = .338$ ;  $p < .001$ ) confirms the assumption that in-

dividualism operates not only on an individual level but also on a cultural one (Hofstede, 2001). Surprisingly, no significant relationship was found between country and collectivism. Individualism correlated highly significantly with the variables prospects on the labor market ( $r = .219, p < .01$ ) and P-O fit ( $r = .226; p < .01$ ) and significantly with the GTM program orientations ( $r = .146; p < .05$ ). This shows that individualism is not only important in terms of culture but also in relation to GTM programs. A correlation with country of origin was found not only for individualism but also for the variables age ( $r = .205; p < .01$ ), work experience ( $r = .191; p < .05$ ) and P-O fit ( $r = .205; p < .01$ ).

**Table 2: Means, standard deviations and correlations of the variables**

Variables	M	SD	1	2	3	4	5	6	8	9	10	11
1. Employer attractiveness	3.80	0.82										
2. Gender	1.56	0.50	.120*									
3. Age	25.72	4.71	-.042	-.057								
4. Country of origin	1.4	0.49	-.047	.028	.205**							
5. Work experience	23.11	30.86	-.017	.063	.473***	.191*						
6. Job market prospects	3.73	0.81	-.041	-.204**	.057	-.039	-.040					
8. Credibility	3.37	0.74	.366***	.127*	-.122*	-.057	.012	-.063				
9. P-O fit	3.31	0.92	.582***	.036	-.062	.205**	-.030	-.017	.300***			
10. Individualism	3.62	0.51	.072	-.081	-.057	.338***	-.066	.219**	0.022	.226**		
11. Collectivism	3.25	0.58	.107	.056	-.175*	-.051	-.096	-.002	0.088	-.092	-.093	
12. GTM (Scenarios)	2.88	1.41	.176**	.097*	-.046	.094	.012	.078	.114*	.255***	.146*	-.035

Note: n = 217, with the exception of work experience n = 175, gender was coded 1 = male, 2 = female. Country of origin was coded 1 = Germany, 2 = GB. Work experience was given in months, GTM contains 1=no GTM program, 2= GTM program without a content-related focus, 3= compensation-oriented GTM program, 4 = career-oriented GTM program, 5 = work-organization oriented GTM program. \*p < .10; \*\*p < .05; \*\*\*p < .01; \*\*\*\*p < .001

Hierarchical regression analyses were used to test the hypotheses. In a first step the variables were z-transformed in order to ensure comparability (Dawson, & Richter, 2006). In a second step dummy variables were formed from the variations of GTM programs in order to measure the influence of the different facets of GTM programs on employer attractiveness (work-organization oriented GTM program = 1; career-oriented GTM program = 1; compensation-oriented GTM program = 1; GTM program without a content-related focus = 1; no GTM = 0).

In order to test hypotheses 1 to 4b, the control variables (gender, age, country of origin, work experience, job market prospects, credibility) in model 1 and the independent variables of the four GTM program orientations and the cultural dimensions individualism and collectivism in model 2 were included in the regression analyses. In model 3 the four interaction systems (career-oriented GTM program \* individualism, compensation-oriented GTM program \* individualism, work-organization-oriented GTM program \* collectivism; work-organization oriented GTM program \* individualism) were included (see Table 3).

**Table 3: Results of the regression analysis to test hypotheses 1, 2, 3, 4a and 4b**

Variables	Model 1	Model 2	Model 3
<b>Control variables</b>			
Gender	.063	.059	.106
Age	-.078	-.051	-.049
Country of origin	-.044	-.074	-.109
Work experience	.020	.031	.034
Job market prospects	-.007	-.039	.022
Credibility	.350***	.337***	.266***
<b>Independent variables</b>			
GTM program without a content-related focus		-.069	-.050
Work-organization oriented GTM program		.120	.143
Career-oriented GTM program		-.030	-.004
Compensation-oriented GTM program		.006	.048
Individualism		.078	.043
Collectivism		.072	.067
<b>Interactions</b>			
Career-oriented GTM program * Individualism			.345***
Compensation-oriented GTM program * Individualism			.152*
Work-organization oriented GTM program * Collectivism			-.078
Work-organization oriented GTM program * Individualism			.101
<b>F</b>	4.740***	2.932**	3.678***
<b>R<sup>2</sup></b>	.145	.178	.271
<b>Adjusted R<sup>2</sup></b>	.114	.118	.198
<b>ΔR<sup>2</sup></b>		.004	.080

Note: Dependent variable: Employer attractiveness; Depicted are the standardized regression coefficients ( $\beta$ );  $n = 175$ ; Adjusted R<sup>2</sup> was calculated using Wherry's (1931) formula; The different GTM programs were dummy coded separately with no GTM program as reference category. + $p < .10$ ; \* $p < .05$ ; \*\* $p < .01$ ; \*\*\* $p < .001$

Model 1 ( $F = 4.740$ ;  $p < .001$ ) has an explanatory power of 11.4% of the variance. This is primarily due to the highly significant influence of credibility ( $\beta = .350$ ;  $p < .001$ ) that is based on the arguments of signaling theory. While credibility is highly significant in all of the models, no further effect of GTM programs without a content-related focus could be detected in model 2 ( $F = 2.932$ ;  $p < .01$ ). Thus the data did not support Hypothesis 1. The variables of model 3 ( $F = 3.678$ ;  $p < .001$ ) have an explanatory power of 19.8% of variance. The interaction between work-organization oriented GTM programs and collectivism and between work-organization oriented GTM programs and individualism which serves to test hypotheses 4a and 4b show no effect. In contrast, the interaction between career-oriented GTM programs and individualism is highly significant ( $\beta = .345$ ;  $p < .001$ ) and the interaction between compensation-oriented GTM programs and individualism is weakly significant ( $\beta = .152$ ;  $p < .10$ ). Although the latter interaction only approaches significance ( $p = .054$ ) this was likely caused by the sample size of the study and therefore a significance level of  $p < .10$  is used in this analysis. Hypotheses 2 and 3 could thus be confirmed.

Figures 2 and 3 show the moderating effects of individualism on the influence of career-oriented and compensation-oriented GTM programs on employer attractiveness respectively.

**Figure 2: Interaction effect between career-oriented GTM programs and individualism**

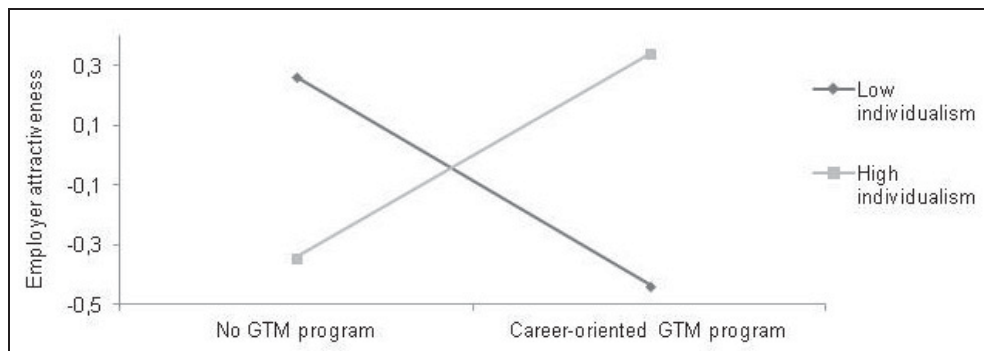

Note: The variables were z-standardized.

The study highlights that companies that do not offer a GTM program are perceived to be more attractive by individuals with a lower individualism score. For companies offering career-oriented GTM programs this effect is reversed: The attractiveness is greater for individuals with a high individualism score, while it falls to a greater extent among individuals with a low individualism score. This thus means that the more individualistic a person is, the greater a career-oriented global management will increase employer attractiveness.

Figure 3 also highlights that companies without a GTM program are perceived to be attractive by individuals with a low individualism score. However, if a company has a compensation-related GTM program, the employer attractiveness of this company for individualistic people increases by half a standard deviation. Less individualistic people perceive companies with compensation-oriented GTM programs to be less at-

tractive than companies without a GTM program. However attractiveness increases much less compared to the increase in attractiveness for people with a high individualism score.

**Figure 3: Interaction effect between compensation-oriented GTM programs and individualism**

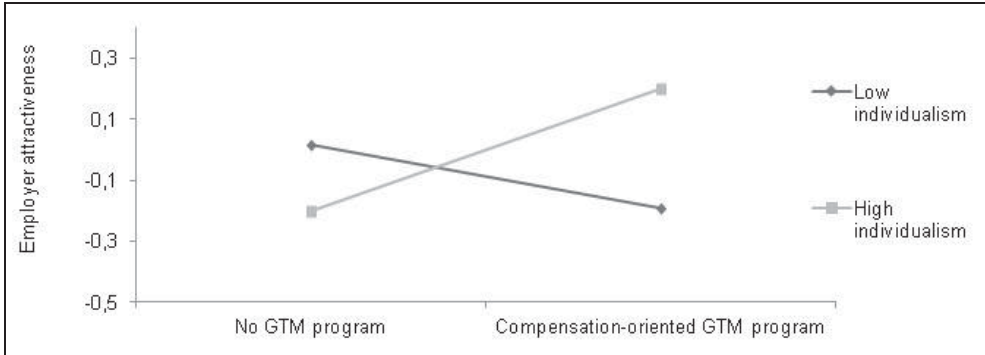

Note: The variables were z-standardized.

Four separate regression analyses were performed in order to test hypothesis 5 and thus to test the mediating effect of the P-O fit on the influence of a focused GTM program on employer attractiveness. As a rule three conditions need to be fulfilled in order to prove a mediator. The independent variable must have a significant effect both on the dependent variable and the mediator, the mediator must have a significant effect on the dependent variable and when the mediator is controlled for, the effect of the independent variable on the dependent variable must decrease or be offset (Baron, & Kenny, 1986, 1176). As shown in Figure 3, the model meets all of these conditions. While without including the P-O fit, a focused GTM program has a significant effect on employer attractiveness, this effect is offset when the P-O fit is controlled for. The P-O fit is therefore a mediator. The indirect effect is made up of the multiplication of the effects of GTM programs on the P-O fit and of the P-O fit on employer attractiveness and is significant ( $\beta = .125$ ;  $p < .01$ ). The mediator thus explains 74.9% (percent of the indirect effect of the direct effect) of the effect of GTM programs with a content-related focus on employer attractiveness.

**Figure 4: Mediating effect of the P-O fit on the influence of GTM programs with a content-related focus on employer attractiveness**

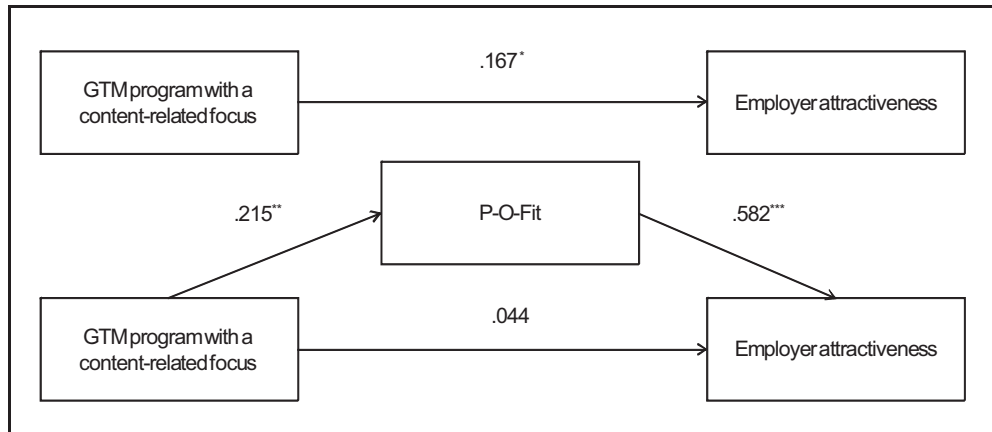

Note: Depicted are the standardized regression coefficients ( $\beta$ ), GTM programs with a content-related focus include work-organization oriented, career-oriented and compensation-oriented GTM programs,  $n = 171$ ;  $^*p < .10$ ;  $^*p < .05$ ;  $^{**}p < .01$ ;  $^{***}p < .001$

## Discussion

This study has aimed to investigate the influence of GTM programs on employer attractiveness modified by culture. The hypotheses on which the investigation was based were mainly confirmed. However, contrary to hypothesis 1, an increase in employer attractiveness through the introduction of GTM programs was not found. This shows that GTM programs do not send positive signals to all individuals and thus do not always increase employer attractiveness. The effect between the countries is possibly canceled out by not including cultural dimensions. This suggestion is supported by various effects that could be detected by integrating cultural dimensions in the study. On the basis of hypotheses 2 and 3 it was established that the signal that companies send out through GTM programs is received by potential talent, processed by them and included in their decision-making. Moreover, cultural differences in the effects of instruments on employer attractiveness were found. The effect of career-oriented GTM programs was strongly influenced by the individualistic nature of people. The focus on career-oriented instruments led to a strong increase in employer attractiveness for these people. The opposite effect was found for people with a low individualism score, who tended to prefer a company with no GTM program (figure 2). In relation to hypothesis 3 there was also a positive effect of compensation-oriented GTM programs on employer attractiveness among individualistic people. At the same time there was a much smaller decrease in employer attractiveness among less individualistic people than was the case with career-oriented instruments. In relation to work-organization oriented GTM programs, no direct or moderated effect on employer attractiveness could be found. Hypotheses 4 a and 4 b could therefore not be confirmed.



Finally, the result of hypothesis 5 shows to what extent the P-O fit, which depicts the fit between the talent's demands and the instruments offered, has an effect on employer attractiveness. The study showed that 74.9% of the influence is attributed to the subjectively perceived P-O fit. Individuals thus compare the three focused variations of GTM programs with their own demands. The higher the perceived fit, the more attractive they perceive the company as an employer. The adaptation of instruments to talent's demands is thus necessary both nationally and internationally in order to increase employer attractiveness through the communication of GTM instruments.

The results highlight that the differentiated use of GTM programs both in recruiting and retaining talent can have several positive effects. Multinational companies in particular are thus able to increase the number of applicants by designing cultural-specific GTM programs. Although individualism and collectivism were measured at the individual level in this study, the results still provide reference points for designing GTM programs at an international level. There is a clear and significant difference in the average score of individualism whereas the average score of collectivism shows just a small difference between Germany (individualism = 3.48 (SD = 0.48); collectivism = 3.27 (SD = 0.58)) and Great Britain (individualism = 3.83 (SD = 0.51); collectivism = 3.21 (SD = 0.59)). The relations between these values are similar to those measured at national level in various studies (e. g. Hofstede, 1980; House, Hanges, Javidan, Dorfman, & Gupta, 2004). It can thus be assumed that Great Britain is more strongly individualistic than Germany, while both countries are similar in terms of collectivism. However, the assessment of the fit between offered GTM program and the required instruments takes place at the level of the individual and is thus much more exact because of the individual measurement of the dimensions.

The results of the study thus provide the following suggestions for the cultural differentiation of GTM programs:

- Where GTM instruments are highly differentiated or GTM instruments are used in countries with a very homogenous cultures and a high individualism score, career-oriented instruments are most effective. While they lead to the highest increase in employer attractiveness for strongly individualistic people compared to the other instrument orientations, they lead to employer attractiveness falling to a greater extent for less individualistic people. It is therefore necessary to differentiate between cultures; otherwise employer attractiveness would decrease on average where individualism of the countries is uniformly distributed.
- Where GTM instruments are less differentiated or GTM instruments are used in countries with a very heterogenous culture, compensation-oriented instruments are suitable. These also lead to an increase in employer attractiveness in strongly individualistic cultures. In less individualistic cultures in contrast, there is little difference in the effect on employer attractiveness between companies with compensation-oriented GTM program and those without a GTM program. Differentiation is therefore to be recommended because of the strong increase in employer attractiveness. However where there is no differentiation the negative effect is not as strong as can be expected for career-oriented GTM programs.

The necessary level of differentiation is therefore dependent on the focus of GTM programs. It makes sense to adapt instruments to the backgrounds of talented individuals in order to achieve as high a possible P-O fit between the talent and the offered instruments. The intensity of individualistic orientation plays a key role here. No effect was found regarding collectivism.

Although the study focuses on the talent recruitment phase and thus primarily investigated the effective use of GTM instruments for this function, the results can at least give hints as to the general cross-cultural design of GTM programs. In order to effectively design GTM programs, the instruments need to be adapted to talent's requirements. Only when there is a fit, will the instruments be accepted and used by talent and only then can the instruments take effect. However, the review of the fit by talent plays a key role in assessment of employer attractiveness too, as was shown in this study by the evidence that the P-O fit is a mediator. As it can be assumed that the cultural influence on needs does not change considerably when individuals join a company, the relationship between cultural influence and design of instruments can be applied to the other GTM functions.

The study thus provides empirical insights into the influence of GTM programs on employer attractiveness and thus contributes to the *literature on GTM* on two counts. First, the nuanced assessment of instruments provides indications of their effectiveness and thus a reference point for the effective design of GTM programs. Second, through the analysis of the relationship between the contents of GTM programs and employer attractiveness, the study makes a contribution to the identification of cultural differences in talent's needs regarding GTM programs. Although such differences in needs and the demands to which they are linked have been largely neglected by the literature to date (McDonnell, 2011, p. 172), they are a key factor in researching the mechanisms of internationally deployed GTM programs. The importance of this factor can be explained through the P-O fit that operates as a mediator on the effect of GTM programs on employer attractiveness.

Alongside the contributions made to research, the results also have *managerial relevance*. The finding that GTM programs do not per se have positive influence on employer attractiveness is for example important for talent recruitment. The limited amount of literature that has considered this relationship has assumed that there is a direct effect here (Yaqub, & Khan, 2011, pp. 61-62). However, the results of this study suggest that the contents of GTM programs need to be adapted to talent's requirements. Thus tailored GTM programs increase employer attractiveness and also aid companies to expedite the self selection of talent by communicating the GTM programs that they deploy. This is preferable for companies because a P-O fit has many positive effects. A P-O fit is for example a predictor for the organizational commitment, employee performance and low fluctuation rates of future employees (O'Reilly, Chatman, & Caldwell, 1991; Kristof-Brown, Zimmermann, & Johnson, 2005). This can enable them to make the recruitment process more efficient and reduce the costs incurred in further recruitment rounds or through the selection of unsuitable candidates. However, it is important that companies deploy the instruments that they communicate because only a consistently designed GTM program can function effectively (McDonnell, & Collings, 2011, p. 70).

Despite these contributions, it is necessary to point to the *limitations of the study*. First, the focus on Masters students of business studies limits the generalizability of the results for students of other subjects and for talented individuals who are already in employment. At the same time, this focus ensures the homogeneity between the test groups that is required in experimental research, thus ensuring high internal validity (Sedlmeier, & Renkewitz, 2008, p. 137). Second, because of the chosen procedure to recruit the participants, the response rate and therefore the non response bias could not be reviewed. Moreover a limitation could result from the high correlation between the construct employer attractiveness and P-O-fit. Even if many studies use these scales at the same time, a relation between the constructs is not disputable. Third, there are limitations regarding the focus on the two countries included in the experiment. Although attention was paid to uniform distribution within the test groups and no significant influence of country of origin on employer effectiveness could be detected, possible distortions cannot be ruled out. The operationalization of culture as individualism and collectivism is a further limitation. Although these dimensions are regarded as the most important in the cross-cultural literature (Parkes, Bochner, & Schneider, 2001; Oyserman, Coon, & Kammelmeyer, 2002), they only represent one element of culture. They can therefore provide first suggestions but cannot fully explain cultural differences. This may provide one explanation as to the rather limited explanatory power of the regression model (19.8%). The personality of the individuals can be a further reason for the limited variance of the model. This was not measured because the study focused on comparing employer attractiveness in different cultures. However personality plays an important role in shaping individuals' needs and thus requires further research in this context.

The empirical study provides first suggestions for designing culturally dependent GTM programs. It also points to areas where *further research* is needed. More research is required to investigate how culture influences talent's demands regarding GTM programs. Such research needs to include further cultural dimensions and other countries in order to provide further recommendations as to how GTM programs needs to be culturally adapted. Moreover, studies need to include talented individuals who are already in work. Although the group focused on in this study form part of potential talent, it can be assumed that their demands on GTM programs may undergo some change when they start working. In order to obtain a more comprehensive picture of talent's demands, it would be necessary to research already identified talent and also other occupational groups. Finally it would be useful for future studies to include further variants of GTM programs in order to achieve more nuanced results as to the effective use of different instruments.

## References

- Adler, N. J., & Jelinek, M. (1990). Is "organizational culture" culture bond? *Human Resource Management*, 25(1), 73-90.
- Baron, R. M., & Kenny, D. A. (1986). The moderator-mediator variable distinction in social psychological research: Conceptual, strategic, and statistical considerations. *Journal of Personality and Social Psychology*, 51(6), 1173-1182.
- Baruch, Y., Budhwar, P. S., & Khatri, N. (2007). Brain drain: Inclination to stay abroad after studies. *Journal of World Business*, 42(1), 99-112.

- Bart, C. K. (2001). Measuring the mission effect in human intellectual capital. *Journal of Intellectual Capital*, 2(3), 320-330.
- Bailyn, L. (1993). *Breaking the mold: Women, men and time in the new corporate world*. New York: Free Press.
- Beechler, S., & Woodward, I. (2009). The global "war for talent". *Journal of International Management*, 15(3), 273-285.
- Bernardin, J. H., & Russell, J. E. A. (1993). *Human resource management: An experiment approach*. New York: McGraw-Hill/Irwin.
- Bernardo, A. B. I. (2010). Extending hope theory: Internal and external locus of trait hope. *Personality and Individual Differences*, 49(8), 944-949.
- Brislin, R. W. (1980). Translation and content analysis of oral and written material. In H. C. Triandis & J. W. Berry (Eds.), *Handbook of cross-cultural psychology* (pp. 389-444). Boston, MA: Allyn & Bacon.
- Brislin, R. W. (1986). The wording and translation of research instrument. In W. J. Lonner (Eds.), *Field methods in cross-cultural research* (pp. 137-164). Thousand Oaks: Sage Publications.
- Cable, D. M., & Judge, T. A. (1996). Person-organization fit, job choice decisions, and organizational entry. *Organizational Behavior and Human Decision Processes*, 67(3), 294-311.
- Capelli, P. (2008). *Talent on demand: Managing talent in an age of uncertainty*. Boston: Harvard Business School Press.
- Chatman, J. A. (1991). Matching people and organizations: Selection and socialization in public accounting firms. *Administrative Science Quarterly*, 36(3), 459-484.
- Connelly, B. L., Certo, T., Ireland, R. D., & Reutzel, C. (2011). Signalling theory: A review and assessment. *Journal of Management*, 37(1), 39-67.
- Darcy, C., McCarthy, A., Hill, J., & Grady, G. (2012). Work-life balance: One size fits all? An exploratory analysis of the differential effects of career stage. *European Management Journal*, 30(2), 111-120.
- Darrough, M. N., & Melumad, N. D. (1995). Divisional versus company-wide focus: The trade-off between allocation of managerial attention and screening of talent. *Journal of Accounting Research*, 33(1), 65-94.
- Davis, T., Cutt, M., Flynn, N., Mowl, P., & Orme, S. (2007). *Talent assessment: A new strategy for talent management*. Cornwall: Gower Publishing.
- Dawson, J. F., & Richter, A. W. (2006). Probing three-way interactions in moderated multiple regression: Development and application of a slope difference test. *Journal of Applied Psychology*, 91(4), 917-926.
- Fiske, A. P. (2002). Using individualism and collectivism to compare cultures – A critique of the validity and measurement of the constructs: Comment on Oyserman et al. (2002). *Psychological Bulletin*, 128(1), 78-88.
- Garavan, T. (2012). Global talent management in science-based firms: An exploratory investigation of the pharmaceutical industry during the global downturn. *International Journal of Human Resource Management*, 23(12), 2428-2449.
- Gomez-Mejina, L. R., & Welbourne, T. (1991). Compensation strategies in a global context. *Human Resource Planning*, 14(1), 29-41.
- Greening, D. W., & Turban, D. B. (2000). Corporate social performance as a competitive advantage in attracting a quality workforce. *Business Society*, 39(3), 254-280.
- Grossman, G. M. (2004). The distribution of talent and the pattern of consequences of international trade. *Journal of Political Economy*, 112(1), 206-239.
- Gunkel, M. (2006). *Country-compatible incentive design. A comparison of employee's performance reward preferences in Germany and the U.S.A.* Wiesbaden: Springer Verlag.
- Hair, J. F., Black, W. C., Babin, B. J., Tatham, R., & Anderson, R. E. (2006). *Multivariate data analysis* (6. ed.), Engelwood Cliffs, New York: Alpha Books.
- Hatun, A. (2010). *Next generation talent management*. Brasingstoke/Hampshire: Palgrave Macmillan.
- Highhouse, S., Lievens, F., & Sinar, E. F. (2003). Measuring attraction to organizations. *Educational and Psychological Measurement*, 63(6), 986-1001.
- Highhouse, S., Thornbury, E. E., & Little, I. S. (2007). Social-identity functions of attraction to organizations. *Organizational Behavior and Human Decision Process*, 103(1), 134-146.

- Hill, E. J., Ferris, M., & Mårtinson V. (2003). Does it matter where you work? A comparison of how three work venues (traditional office, virtual office, and home office) influence aspects of work and personal/family life. *Journal of Vocational Behavior*, 63(2), 220-241.
- Hofstede, G. (1980). *Culture's consequences: International differences in work-related values*. Newbury Park: Sage Publications.
- Hofstede, G. (1991). *Cultures and organizations: Software of the mind*. London: McGraw-Hill.
- Hofstede, G. H. (2001). *Culture's consequences. Comparing values, behaviors, institutions, and organizations across nations*. (2. ed.), Thousand Oaks et al.: Sage Publications.
- House, R. J., Hanges, P. J., Javidan, M., Dorfman, P. W., & Gupta, V. (2004). *Culture, leadership, and organizations. The GLOBE study of 62 societies*. Thousand Oaks, London, New Delhi: Sage Publications.
- Hoye, G. v., & Lievens, F. (2007). Social influences in organizational attractiveness: Investigation if and when word of mouth matters. *Journal of Applied Social Psychology*, 37(9), 2024-2047.
- Hu, C., Su, H.-C., & Chen, C.-I. B. (2007). The effect of person-organization fit feedback via recruitment web sites on applicant attraction. *Computers in Human Behavior*, 23(5), 2509-2523.
- Huang, J., & Tansley, C. (2012). Sneaking through the minefield of talent management: The notion of rhetorical obfuscation. *International Journal of Human Resource Management*, 23(17), 3673-3691.
- Hui, C.H., Yee, C., & Eastman, K. L. (1995). The relationship between individualism-collectivism and job satisfaction. *Applied Psychology: An International Review*, 44(3), 276-282.
- Iles, P., Chuai, X., & Preece, D. (2010). Talent management in HRM in multinational companies in Beijing: Definitions, differences and drivers. *Journal of World Business*, 45(2), 179-189.
- Judiesch, M. K., & Lyness, K. S. (1999). Left behind? The impact of leaves of absence on managers' career success. *Academy of Management Journal*, 42(6), 641-651.
- Kristof, A. L. (1996). Person-organization fit: An integrative review of its conceptualizations, measurement, and implications. *Personnel Psychology*, 49(1), 1-49.
- Kristof-Brown, A. L., Zimmerman, R. D., & Johnson, E. C. (2005). Consequences of individual's fit at work: A Meta-analysis of person-job, person-organization, person-group, and person-supervisor fit. *Personnel Psychology*, 58(2), 281-342.
- Kruskal, W. H., & Wallis, W. A. (1952). Use of ranks in one-criterion variance analysis. *Journal of the American Statistical Association*, 47(260), 583-621.
- Kurland, N. B., & Bailey, D. E. (1999). When workers are here, there, and everywhere: A discussion of the advantages and challenges of telework. *Organizational Dynamics*, 28(2), 53-58.
- Lievens, F., Decaestecker, C., Coetsier, P., & Geirnaert, J. (2001). Organizational attractiveness for prospective applicants: A person-organization fit perspective. *Applied Psychology: An International Review*, 50(1), 30-51.
- Martin, G., & Groen-in't-Woud, S. (2011). Employer branding and corporate reputation management in global companies: A signaling model and case illustration. In H. Scullion, & D. G. Collings (Eds.), *Global talent management* (pp. 87-110). New York: Routledge.
- McDonnell, A. (2011). Still fighting the „war for talent“? Bridging the science versus practice gap. *Journal of Business Psychology*, 26(2), 169-173.
- McDonnell, A., & Collings, D. G. (2011). The identification and evaluation of talent in MNEs. In H. Scullion, & D. G. Collings (Eds.), *Global talent management* (pp. 56-73). New York: Routledge.
- Milkovich, G. T., Newman, J., & Gerhart, B. A. (2011). *Compensation* (10. ed.). New York: McGraw-Hill/Irwin.
- Montgomery, D. C. (2012). *Design and analysis of experiments* (9. ed.). John Wiley & Sons Inc..
- Mullen, M. R. (1995). Diagnosing measurement equivalence in cross-national research. *Journal of International Business Studies*, 26(3), 573-596.
- Ng, E. S. W., & Burke, R. J. (2005). Person-organization fit and the war for talent: Does diversity management make a difference? *The International Journal of Human Resource Management*, 16(7), 1195-1210.
- O'Reilly, C., Chatman, J., & Caldwell, D. F. (1991). People and organizational culture: A profile comparison approach to assessing person-organization fit. *The Academy of Management Journal*, 34(3), 487-516.



- Oyserman, D., Coon, H. M., & Kemmelmeier, M. (2002). Rethinking individualism and collectivism: Evaluation of theoretical assumptions and meta-analyses. *Psychological Bulletin*, 128(1), 3-72.
- Parkes, L. P., Bochner, S., & Schneider, S. K. (2001). Person-organization fit across cultures: An empirical investigation of individualism and collectivism. *Journal of Applied Psychology: An international Review*, 50(1), 81-108.
- Piansoongnern, O., Anurit, P., & Bunchapattanasakda, C. (2008). Managing talented employees: A study of leading corporations in Europe. *European Journal of Social Sciences*, 6(1), 70-90.
- Ramamoorthy, N., & Carroll, S. J. (1998). Individualism/collectivism orientations and relations toward alternative human resource management practices. *Human Relations*, 51(5), 571-588.
- Ramamoorthy, N., Gupta, A., Sardessai, R. M., & Flood, P. C. (2005). Individualism/collectivism and attitudes towards human resource systems: A comparative study of American, Irish and Indian MBA students. *International Journal of Human Resource Management*, 16(5), 852-869.
- Ready, D. A., & Conger, J. A. (2007). Make your company a talent factory. *Harvard Business Review*, 85(6), 68-77.
- Ready, D. A., Hill, L. A., & Conger, J. A. (2008). Winning the race for talent in emerging markets. *Harvard Business Review*, 86(11), 62-72.
- Rynes, S. L., & Cable, D. M. (2003). Recruiting research in the 21st century: Moving to a higher level. In W. Borman, D. Ilgen, & R. Klimoski (Eds.), *Handbook of psychology, industrial and organization psychology* (12. ed., pp. 55-76). Hoboken, New Jersey: John Wiley & Sons Inc.
- Saks, A. M., & Ashforth, B. E. (1997). A longitudinal investigation of the relationships between job information sources, applicant perceptions of fit, and work outcomes. *Personnel Psychology*, 50(2), 395-426.
- Schneider, B., Smith, D. B., Taylor, S., & Fleener, J. (1998). Personality and organizations: A test of homogeneity of personality hypothesis. *Journal of Applied Psychology*, 83(3), 462-470.
- Schuler, R. S., Jackson, S. E., & Tarique, I. (2011a). Global talent management and global talent challenges: strategic opportunities for IHRM. *Journal of World Business*, 46(4), 506-516.
- Schuler, R. S., Jackson, S. E., & Tarique, I. (2011b). Framework for global talent management: HR actions for dealing with global talent challenges. In H. Scullion, & D. G. Collings (Eds.), *Global Talent Management* (pp. 17-36). New York: Routledge.
- Scullion, H., & Collings, D. G. (2011). Global talent management: Introduction. In H. Scullion, & D. G. Collings (Eds.), *Global Talent Management* (pp. 3-16). New York: Routledge.
- Scullion, H., Collings, D. G., & Caliguri P. (2010). Global talent management. *Journal of World Business*, 45(2), 105-108.
- Sedlmeier, P., & Renkewitz, F. (2008). *Forschungsmethoden und Statistik in der Psychologie*. München: Pearson.
- Shulruf, B. (2008). Theory and practice in the use and interpretation of Likert-type scales within a cross-cultural context. In L. Palcroft, & M. Lopez (Eds.), *Personality assessment: New research* (pp. 237-258). New York: Nova Publishing.
- Shulruf, B., Hattie, J., & Dixon, R. (2007). Development of a new measurement tool for individualism and collectivism. *Journal of Psychoeducational Assessment*, 25(4), 385-401.
- Shulruf, B., Hattie, J., & Dixon, R. (2011). Intertwinement of individualist and collectivist attributes and response sets. *Journal of Social, Evolutionary, and Cultural Psychology*, 5(1), 51-65.
- Sigall, H., & Mills, J. (1998). Measures of independent variables and mediators are useful in social psychology experiments: But are they necessary? *Personality and Social Psychology Review*, 2(3), 218-226.
- Singelis, T. M. (1994). The measurement of independent and interdependent self-construals. *Personality and Social Psychology Bulletin*, 20(5), 580-591.
- Smith, P. B., Dugan, S., & Trompenaars, F. (1996). National culture and the values of organizational employees: A dimensional analysis across 43 nations. *Journal of Cross-Cultural Psychology*, 27(2), 231-264.
- Sondergaard, M. (1994). Research note: Hofstede's consequences: A study of reviews, citations and replications. *Organizational Studies*, 15(3), 449-456.
- Spence, M. (1973). Job market signaling. *Quarterly Journal of Economics*, 87(3), 355-374.



- Stahl, G. K., Björkman, I., Farndale, E., Morris, S. S., Paauwe, J., Stiles, P., Trevor, J., & Wright, P. M. (2007). Global talent management: How leading multinationals build and sustain their talent pipeline. *INSTEAD Working Paper Series*, Fontainebleau.
- Suh, E., Diener, E., Oishi, S., & Triandis, H. C. (1998). The shifting basis of life satisfaction judgment across cultures: emotions versus norms. *Journal of Personality and Social Psychology*, *74*(2), 482-493.
- Tansley, C., Harris, L. M., Stewart, J., & Turner, P. A. (2006). *Talent management: Understanding the dimensions*. London.
- Thomas, K. M., & Wise, P. G. (1999). Organizational attractiveness and individual differences: Are diverse applicants attracted by different factors? *Journal of Business and Psychology*, *13*(3), 375-390.
- Tranks, C. Q., Rynes, S. L., & Bretz, R. D. Jr. (2002). Attracting applicants in the war for talent: Differences in work preferences among high achievers. *Journal of Business and Psychology*, *16*(3), 331-345.
- Triandis, H. C. (1995). *Individualism and collectivism*. Boulder, CO: Westview Press.
- Triandis, H. C., Bontempo, R., Villareal, M. J., Asai, M., & Lucca, N. (1988). Individualism and collectivism – Cross-cultural perspectives on self ingroup relationship, *Journal of Personality and Social Psychology*, *54*(2), 323-338.
- Triandis, H. C., Brislin, R., & Hui, H. C. (1988). Cross-cultural training across the individualism-collectivism divide. *International Journal of Intercultural Relations*, *12*(3), 269-289.
- Triandis, H. C., & Gelfand, M. J. (1998). Converging measurement of horizontal and vertical individualism and collectivism. *Journal of Personality and Social Psychology*, *74*(1), 118-128.
- Wagner, J. A. (1995). Studies of individualism-collectivism: Effects on cooperation in groups. *Academy of Management Journal*, *38*(1), 152-172.
- Wherry, R. J. (1931). A new formula for predicting the shrinkage of the coefficient of multiple correlation. *Annals of Mathematical Statistics*, *2*(4), 440-451.
- Williams, M. L., & Bauer, T. N. (1994). The effect of a managing diversity policy on organizational attractiveness. *Group & Organization Management*, *19*(3), 295-308.
- Winkler, J. (2009). *Talent management*. Hamburg.
- Yaqub, B., & Khan, M. A. (2011). The role of employer branding and talent management for organizational attractiveness. *Far East Journal of Psychology and Business*, *5*(1), 57-65.
- Zheng, C. (2009). Keeping talents for advancing service firms in Asia. *Journal of Service Management*, *20*(5), 482-502.