

Jones, Ronald Winthrop; Takemori, Shumpei

**Working Paper**

## Foreign monopoly and optimal tariffs for the small open economy

Diskussionsbeiträge - Serie II, No. 65

**Provided in Cooperation with:**

Department of Economics, University of Konstanz

*Suggested Citation:* Jones, Ronald Winthrop; Takemori, Shumpei (1988) : Foreign monopoly and optimal tariffs for the small open economy, Diskussionsbeiträge - Serie II, No. 65, Universität Konstanz, Sonderforschungsbereich 178 - Internationalisierung der Wirtschaft, Konstanz

This Version is available at:

<https://hdl.handle.net/10419/101582>

**Standard-Nutzungsbedingungen:**

Die Dokumente auf EconStor dürfen zu eigenen wissenschaftlichen Zwecken und zum Privatgebrauch gespeichert und kopiert werden.

Sie dürfen die Dokumente nicht für öffentliche oder kommerzielle Zwecke vervielfältigen, öffentlich ausstellen, öffentlich zugänglich machen, vertreiben oder anderweitig nutzen.

Sofern die Verfasser die Dokumente unter Open-Content-Lizenzen (insbesondere CC-Lizenzen) zur Verfügung gestellt haben sollten, gelten abweichend von diesen Nutzungsbedingungen die in der dort genannten Lizenz gewährten Nutzungsrechte.

**Terms of use:**

*Documents in EconStor may be saved and copied for your personal and scholarly purposes.*

*You are not to copy documents for public or commercial purposes, to exhibit the documents publicly, to make them publicly available on the internet, or to distribute or otherwise use the documents in public.*

*If the documents have been made available under an Open Content Licence (especially Creative Commons Licences), you may exercise further usage rights as specified in the indicated licence.*

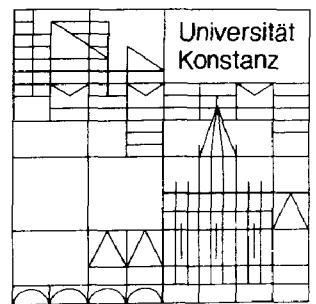

**Sonderforschungsbereich 178**  
**„Internationalisierung der Wirtschaft“**

Diskussionsbeiträge

Juristische  
Fakultät

Fakultät für Wirtschafts-  
wissenschaften und Statistik

---

Ronald W. Jones  
Shumpei Takemori

**Foreign Monopoly and Optimal Tarifes**  
**for the Small Open Economy**

FOREIGN MONOPOLY AND OPTIMAL TARIFFS  
FOR THE SMALL OPEN ECONOMY

Ronald W. Jones<sup>1</sup>  
Shumpei Takemori<sup>2</sup>

Serie II - Nr. 65

Mai 1988

(Revised Draft)

<sup>1</sup>Visiting from the University of Rochester

<sup>2</sup>University of Rochester

## 1. Introduction

A hallmark of the position faced by small open economies in markets characterized by perfect competition is the lack of ability to influence their terms of trade by levying a tariff. Barring externalities or distortions which support second-best arguments for commercial policy intervention, a small open economy's optimal tariff rate is zero. However, this prescription may be altered if the small country faces an external monopolistic supplier in its market for importables. Brander and Spencer (1981, 1984), Krugman (1986) and others have pointed to the potential for rent or profit-extraction when a country faces a monopolist who is making profits. Crucial to their discussion is the ability of the monopolist to discriminate among markets, such price discrimination made possible by natural barriers between countries. Our object in the present paper is to analyze both the ability of a small open economy to influence the price it pays to an outside monopolist for its importables and the desirability of doing so when careful attention is paid to the fact that by definition a small open economy shares a world market with many other (small or large) trading communities. Furthermore, the effectiveness of a tariff is highlighted by assuming that no natural barriers (transport costs) exist to provide segmentation among the markets supplied by

the foreign monopolist. Market segmentation emerges solely as a consequence of the tariff.<sup>1</sup> Indeed, the ability of a small country to influence supply price stems from its sovereign power to provide a market area isolated to some extent from other markets by its tariff wall. The degree of market segmentation may be a "given" to private firms, but is a crucial endogenous variable to governments even of economies with little ability to alter conditions in outside world markets. We argue that a small open economy can almost always manage to improve its terms of trade, although this may require it to impose a high tariff. Nonetheless, it may choose to follow a free-trade policy instead, even if there is no danger of tariff retaliation.

If the small open economy were effectively segmented from the rest of the monopolist's markets by high natural barriers (transportation costs), a tariff could be expected to have some effect on the price charged by the monopolist. Three cases are possible:

(i) The price charged by the monopolist could be depressed by the tariff (the home country improves its terms of trade), but by less than the level of the tariff so that the domestic price to consumers at home rises. We call this the "normal" result and deal with this case in sections 2 and 3 of the paper. Our general discussion is supplemented by devoting some attention to the special case of linear demand, which falls in the middle of the range of demand behavior yielding these normal results.

(ii) The price charged by the monopolist could be so depressed by the tariff that the domestic price of importables also falls. In competitive

---

<sup>1</sup>The importance of a tariff in allowing market segmentation is a theme developed earlier by Horst (1971), who focussed on transfer pricing by a foreign monopolist when it controls a subsidiary located in the home consuming country. The issue of transfer pricing is also considered by Katrak (1977).

settings this is referred to as the Metzler paradox. As we point out, this is a possible outcome, but requires a sufficiently bowed-out shape for the home demand curve. In any event, the implications of such a possibility are sketched out in section 4.

(iii) The monopolist might respond to the home tariff by raising its supply price. This case received some notoriety by its exposure in Brander and Spencer (1984), further analyzed in Jones (1987), and is generally associated with demand curves highly bowed in towards the origin. It provided the foundation in the Brander and Spencer analysis for the argument that a country might improve its terms of trade by granting a subsidy on imports instead of levying a tariff. Section 5 discusses this case.

Sections 2 through 5 proceed to examine each of these cases not only when markets are segmented by natural barriers, but as well when the only element providing market separation is the home country's tariff. As we demonstrate, a crucial characteristic affecting the manner in which markets in the rest of the world inhibit the monopolist's options in the small open economy is the extent and type of asymmetry between demand behavior at home and that found on average in the rest of the world. Section 2 of our paper focusses on the optimal choices made by the supplying monopolist when increasing protection at home effectively widens the monopolist's range of options. Section 3 completes the analysis of the "normal" case by turning to the choices available to the small tariff-levying country. Whereas the monopolist selects a supply price in order to maximize its profits, the home country chooses a tariff rate in order to maximize its real income. The existence of many other markets served by the monopolist serves to preclude more interactive strategic behavior by either the monopolist or the small country in this process.

The manner in which protective policies by the rest of the world affect the home country's real income and the monopolist's pricing decisions in the home market is analyzed in section 6. The paper concludes with summary remarks on optimal tariff policy by a small open economy facing a monopolistic supplier.

## 2. Optimal Pricing Strategy for the Monopoly Supplier

The initial setting is deliberately kept simple. An external monopolist is the only supplier of a product to a world market consisting both of a small open economy (referred to as the home country) and a large set of other countries (the rest of the world). Transport costs, which might be expected to provide a natural umbrella for market segmentation, are explicitly assumed away. As a further simplification, we assume not only that the monopolist faces no producer rivals elsewhere in the world, but also serves no domestic consumers in its own country.

The home country is small in the sense that any alteration in its demand is too negligible either to affect the marginal cost of the monopolist ( $c^*$ ) or to influence the monopolist's choice of supply price in markets in the rest of the world. The economy is specialized in its production of an export commodity which is freely traded on competitive world markets at a given price. This commodity is selected as the numeraire. If the home country follows a free-trade policy it faces price  $p^{**}$  for its importable, where  $p^{**}$  is the price chosen by the monopolist for all countries in an integrated world market. When demand conditions in the home country are not typical of the

average of those in the rest of the world, this  $p^{**}$  will not be the price the monopolist would desire to charge the home country if it could segment the home market and thus not allow agents at home or in the rest of the world to spoil the monopolist's other market.

In order to analyze the way in which a tariff introduces some leeway for the monopolist's desire to indulge in price discrimination, we examine first how monopoly profits would depend on the price it would charge to the small, open economy if there were complete market segmentation. Let  $p^*$  indicate the price charged by the monopolist to the home country, and  $p$  denote the price faced by consumers at home after the imposition of the tariff. The  $\pi^*(p^*)$  curve in Figure 1 shows the free-trade profit function for the monopolist. With marginal costs,  $c^*$ , representing average costs of the monopolist's sales to the small open economy, profits are:

$$(1) \quad \pi^* = (p^* - c^*)D(p, T).$$

where  $D(p, T)$  indicates that local demand depends upon the domestic price of importables for any given tariff rate. This demand curve would incorporate income effects, but since a rise in the tariff rate,  $T$ , would associate any given domestic price with a lower world price and thus a higher level of real income, the demand curve would shift outwards with a rise in  $T$ .<sup>2</sup>

---

<sup>2</sup>To simplify our algebraic treatment of the linear case, we will assume for that case only that the home marginal propensity to consume importables is zero, an assumption in line with treatments of the tariff issue in a partial equilibrium setting.



For convenience in what follows we restrict our attention to the use of a specific tariff, so that:

$$(2) \quad p = p^* + T$$

For a prescribed level of the tariff rate, differentiation of (1) reveals:

$$(3) \quad \frac{\partial \pi^*}{\partial p^*} = D \left\{ 1 - \frac{(p^* - c^*)}{p^* + T} \epsilon \right\},$$

where  $\epsilon$  is defined as the absolute value of the domestic elasticity of demand for importables supplied by the monopolist. For each value of  $T$ , this serves to define the monopolist's supply price,  $p_m^*$ , which maximizes profits:

$$(4) \quad p_m^* = \frac{T + c^* \epsilon}{\epsilon - 1}.$$

At initial free trade we indicate the supply price which maximizes profits as  $p_0^*$ , and the locus passing through the peaks of various tariff-restricted profit functions is shown by the curve MM in Figure 1, as at point A for tariff rate  $T_A$ . The tariff shifts the profit function downwards since any given  $p^*$  is now associated with a higher domestic price and thus a restricted volume of sales. By our previous assumption, in this and the succeeding two sections the MM curve is positively sloped, so that increasing the tariff would improve the terms of trade in a country whose market was segmented by high transport costs from the rest of the world. However, it is also assumed in this "normal" case that the terms-of-trade gain falls short of the tariff

wedge; maximum point A in Figure 1 lies strictly within the shaded area bounded by  $p_o^* - T_A$  and  $p_o^*$ .<sup>3</sup>

The behavior of the MM curve passing through the peaks of the tariff-restricted profit functions depends on the effect of protection on the elasticity of demand. Differentiation of (4) with respect to  $T$  yields:<sup>4</sup>

$$(5) \quad \frac{dp_m^*}{dT} = \frac{(\epsilon - 1) - (c^* + T)\frac{d\epsilon}{dT}}{(\epsilon - 1)^2}.$$

We are assuming, in the "normal" case, that a tariff raises demand elasticity sufficiently that expression (5) is negative but greater than -1. This is certainly the case for a linear demand curve but, as Brander and Spencer (1984) point out,  $dp_m^*/dT$  is positive in the case of constant demand elasticity (section 5).

The price which the monopolist selects to charge the home country is restricted if the monopolist sells in the rest of the world as well. If trade is unrestricted everywhere, markets are integrated and the monopolist must

---

<sup>3</sup>In the case of a linear demand curve of the form  $D = \frac{a}{b}(b - p)$ , the profit function is  $\pi^* = \frac{a}{b}(p^* - c^*)(b - p)$ . (Recall from footnote 2 that the marginal propensity to import is assumed to be zero for this linear case). As can easily be checked, the MM curve in this linear case connects  $c^*$  with peak point M by a positively sloped curve with positive second derivative. At any point such as A, the MM curve is twice as steep as a ray from  $c^*$  to A.

<sup>4</sup>In the case of ad valorem tariffs,  $p_m^*$  equals  $\frac{\epsilon}{(\epsilon - 1)} \cdot c^*$  so that an increase in the rate of duty lowers  $p_m^*$  if and only if it also raises the absolute value of demand elasticity. Thus in the constant elasticity case the MM curve in Figure 1 would be vertical if an ad valorem tariff is the protectionist instrument selected.

charge  $p^{**}$  in the small home country if it chooses to charge  $p^{**}$  in the rest of the world.<sup>5</sup> Once the home country protects its local market, a range for  $p^*$  is opened up. But it is only a range. The price charged to the small open economy,  $p^*$ , must lie in the closed interval  $[p^{**} - T, p^{**}]$ . Any  $p^*$  lower than this would allow agents in the small, protected, economy to buy from the monopolist and then, even after paying duty,  $T$ , to undercut the monopolist in the rest of the world. Any  $p^*$  higher than  $p^{**}$  would allow agents in the rest of the world to undersell the monopolist in the home country. Of course two caveats must be added. We assume the home tariff is non-discriminatory, so that  $T$  applies to any potential entrant. Furthermore, we assume that no agent at home can get a tariff rebate in order to re-export. This is crucial, for if the latter were possible, the monopolist could not afford to charge any price to the home country lower than  $p^{**}$ .

We label as the "benchmark" case the one in which the home country's demand elasticity is similar to that in the rest of the world. If so, free-trade peak  $p_0^*$  corresponds to  $p^{**}$  and the monopolist can choose any price in range  $[p_0^* - T, p_0^*]$ . For tariff level  $T_A$  in Figure 1 point A is selected, and by our assumption this represents an interior solution so that the foreign supply price is driven down by less than the tariff. (A curve, not drawn, showing domestic price in Figure 1 would thus be negatively sloped from the peak). Although in this benchmark case the monopolist would in the free-trade situation choose the same supply price in each market, whether or not the home market is segmented, a home tariff alters the monopolist's decision. It now chooses to charge a lower price in the home market; the tariff has raised the elasticity of demand at home.

---

<sup>5</sup> Imagine a  $\pi^{**}$  function representing the monopolist's profits in the rest of the world. This reaches a peak at price  $p^{**}$ .

To proceed from this benchmark case, assume now that home and foreign demand conditions differ. The two types of asymmetry are illustrated in Figure 2. An initial price,  $(p^{**})'$ , set by the monopolist in a tariff-free world corresponds to a state in which the elasticity of demand at home is higher than its average value in the rest of the world. As a consequence, the monopolist in an integrated market is forced to forego the opportunity to discriminate (by charging  $p_0^*$ ) because arbitrage possibilities open to home agents rule out such discriminatory behavior. The home tariff has two effects on the monopolist. It reduces its profit level and it enlarges the set of possible prices it can charge in the home country. The tariff-restricted profit function for tariff rate  $T_A$  reaches a peak at A, but this point is not open to the monopolist; instead, optimal monopoly choice in the range  $[(p^{**})' - T_A, (p^{**})']$  is shown by point B. In such a case the home country, by levying a tariff, improves its terms of trade by the full amount of the duty. Domestic prices remain at their initial level,  $(p^{**})'$ .

The alternative scenario has demand relatively less elastic at home than in world markets so that  $(p^{**})''$  is lower than  $p_0^*$ , the price the monopolist would choose in the home market if it could discriminate. In free trade the home country has been a "free rider" in that it benefits from the fact that potential arbitrage has allowed it to consume at the relatively low price,  $(p^{**})''$ . If the economy were to levy a tariff, its small size does not disturb world  $(p^{**})''$ . Instead, a range of choices is opened up to the monopolist, although it selects to maintain supply price to the home country at  $(p^{**})''$ . Profit level at E is lower than at the free-trade level, but in the restricted circumstances it represents the best the monopolist can do. The home country has not improved its terms of trade. Indeed, the higher domestic price now reduces its import volume and this entails real losses.

These alternative scenarios reveal that the optimal response for a monopolist depends radically on whether demand at home is more or less elastic than in the rest of the world. But it also reveals that the monopolist's optimal choice depends on the rate of protection. Even if a small tariff pushes the monopolist to one extreme end of the allowable range or the other, a sufficiently large tariff will encourage the monopolist to select a supply price strictly within the range provided by the tariff wall. We label this tariff rate  $T_S$ , the rate which offers a sufficient degree of market segmentation so that the monopolist's choice corresponds to that made in the benchmark case, and illustrate it for the two ways in which the home country's tastes differ from the average in the rest of the world:

(i) In Figure 3(a) the world price (and initial domestic price),  $p^{**}$ , lies above the price the monopolist would charge at home if markets were segmented,  $p_o^*$ . As tariffs are increased, so is the spread within which the monopolist is constrained by potential "second-hand" competition from its other customers. Tariff rate,  $T_S$ , provides the minimum sufficient degree of protection that allows the peak of a tariff-restricted profit function to come within the allowable range. Note that  $T_S$  exceeds the gap between initial price,  $p^{**}$ , and the price the monopolist would charge in a segmented home market if there were no tariffs,  $p_o^*$ . The tariff keeps shifting leftwards the peak along the monopolist's profit function, although by less than the tariff hike, so that the tariff band catches up with the MM curve only at a supply price,  $p_m^*(S)$ , significantly lower than  $p_o^*$ .

(ii) In Figure 3(b) world (and initial home country) price,  $p^{**}$ , lies below the rate the monopolist would charge at home if natural market segmentation were possible. The home country, in effect, has been a

free-rider on other countries' relatively high elasticity of demand. The band of prices within which the monopolist may choose its supply price again runs to the left of  $p^{**}$ . As tariffs are raised, however, the monopolist keeps selecting the high end of the range,  $p^{**}$ , until, at rate  $T_S$ , this corresponds to the peak of a tariff-restricted profit function at the point where MM intersects the vertical line showing  $p^{**}$ . Curve MM' has been constructed so that the horizontal gap between it and MM also represents the tariff. At rate  $T_S$  domestic price corresponds to  $\underline{S}'$ .

Figure 4 is designed to illustrate explicitly the optimal choice of supply price made by the monopolist in the two asymmetric situations shown in Figure 3 as well as in the benchmark case. The latter is illustrated in Figure 4(c), with world price,  $p^{**}$ , equal to the optimal choice for the supplying monopolist in a segmented but unprotected home market,  $p_0^*$ . The shaded area illustrates the range  $[p^{**} - T, p^{**}]$  of choice for the monopolist's supply price, and in the "normal" case the optimal choice lies within this range. (A positively sloped curve, not drawn, everywhere distance  $T$  above this curve would illustrate the domestic price behind the home tariff wall). By contrast in Figure 4(a) the monopolist would, in a segmented free-market scenario, have charged price  $p_0^*$  lower than the price charged to the rest of the world,  $p^{**}$ , but is prevented from doing so by the lack of natural barriers. As the home country levies a tariff, the monopolist can (and would) drop its supply price dollar for dollar to match the tariff hike until rate  $T_S$  is reached. For higher tariff rates, the monopolist continues to lower its supply price, but not by the full amount of the tariff cut - at rates higher than  $T_S$  the domestic price to consumers at home begins to rise. Finally, in Figure 4(b), for rates below  $T_S$  the monopolist keeps supply price

constant - the domestic price rises to take the full brunt of the tariff. Only for rates higher than  $T_S$  will the monopolist lower its supply price.<sup>6</sup>

Can the small open economy improve its terms of trade by imposing a tariff on its supplying monopolist? In all these cases the answer is "yes" - although in case (b) rates of duty below some critical level ( $T_S$ ) leave the terms of trade unaffected. This case is the one that most closely corresponds to the classic situation faced by a small open economy facing competitive suppliers for its importables: a tariff would serve only to raise domestic price and would have no effect on world prices. Here the small open economy's tariff likewise has no effect on world  $p^{**}$ , but it does open up a range of possible supply prices for the monopolist. But the monopolist would have liked to charge a higher price than  $p^{**}$  to the home country initially, and was prevented from doing so by the threat of entry into the home market from the customers it has supplied in the rest of the world. Although the tariff opens up a range of possible  $p^*$  supply prices, it does not increase the upper end of this range so that the monopolist clings to  $p^{**}$  until tariff rate  $T_S$  is set. For higher rates it pays the monopolist to lower supply price to the small open economy.

All this focusses on the choices open to the monopolist. Given that the home country can find tariff rates sufficiently high to improve its terms of trade, will it find it optimal to levy such tariffs? We turn now to this issue.

---

<sup>6</sup>In the case of linear demand, in the benchmark case (Figure 4(c)) the monopolist responds by lowering price fifty cents for each dollar of the tariff - the  $p_m^*$  curve is linear from  $p_o^*$  with slope  $-1/2$ .

### 3. The Optimal Tariff Rate

The benchmark case, in which symmetry between the home country's demand elasticity and the average elasticity in other countries' markets would encourage the monopolist to charge the same price in all even in naturally segmented markets, illustrates how tariff policy at home is concerned with comparing terms-of-trade effects and volume-of-trade effects. The standard textbook decomposition of the effect of a tariff change on home real income,  $y$ , is:

$$(6) \quad \frac{dy}{dT} = -D \frac{dp^*}{dT} + T \frac{dD}{dT}.$$

Local demand for importables (or the volume of imports) depends upon local price and the tariff rate, so that a further decomposition yields:

$$(7) \quad \frac{dy}{dT} = \frac{-D}{\left\{1 - \left(\frac{T}{p^* + T}\right)m\right\}} \left\{ \frac{dp^*}{dT} + \frac{T\varepsilon}{(p^* + T)} \frac{dp}{dT} \right\}.$$

where, as before,  $\varepsilon$  is the absolute value of home demand elasticity and  $m$  represents home marginal propensity to import. In the benchmark case for the "normal" scenario, an increase in  $T$  improves the terms of trade ( $dp^*/dT$  negative), but raises domestic price ( $dp/dT$  positive). Therefore real income rises for small tariffs, but as the tariff wedge gets larger, the negative volume-of-trade effect dominates. The result is the relationship between real



income and the tariff rate shown by the curve in Figure 5.<sup>7</sup> Thus in the benchmark case the optimum tariff is of finite level, but not so high as to choke off trade. The result is much the same as in the classical competitive case.<sup>8</sup>

Asymmetry in home tastes, leading to a discrepancy between world price,  $p^{**}$ , and the free-trade price the monopolist would charge at home in the case of natural market segmentation,  $p_0^*$ , leads to the variations shown in Figures 6(a) and 6(b). The two cases shown in Figure 6(a) correspond to Figure 4(a)'s depiction of the monopolist's choice for its optimal supply price,  $p^*$ , given that world  $p^{**}$  exceeds  $p_0^*$ . If the average elasticity of demand in the world is not too much lower than at home - situation prime (') - small tariffs improve the terms of trade dollar for dollar. Along this early stretch domestic price does not rise, but real income does. Therefore demand rises and the value of  $dy/dT$  in (7) gets slightly higher, accounting for the ever-steeper upward-rising curve from  $y_0'$  in Figure 6(a). However, the value of the tariff sufficient to reproduce full segmentation ( $T_S'$ ) is quite low. As a consequence the optimal tariff,  $T_{opt}'$ , is the same as in the benchmark case.

In situation double prime (") the world's demand elasticity is assumed to be even less. Therefore initially real income at home ( $y_0''$ ) is lower and a higher tariff wall is required before the degree of segmentation is sufficient for the monopolist to be able to reach the peak of its tariff-restricted profit function. This rate is also the optimal rate ( $T_{opt}''$ ). In the (") situation domestic price has remained constant for tariff increases up to this

---

<sup>7</sup>See, for example, the standard diagram in Caves and Jones (1985), p. 213.

<sup>8</sup>In the case of linear demand the optimum tariff for the benchmark case is one-third the height of the prohibitive tariff.

rate, but would rise thereafter. The cut-back in demand shown by the second term in equation (6) would at this high tariff rate have such a strong negative influence on real income as to dominate the continuing terms-of-trade improvement.<sup>9</sup>

Figure 6(b) illustrates three qualitatively different outcomes when the home country has benefitted from being part of an integrated world market in the free-trade state, free-riding on a higher average elasticity of demand in the rest of the world. In such a case the presumption is that providing the monopolist the opportunity to discriminate will harm the home country. In the triple-prime situation ("") in Figure 6(b) initial supply price  $p^{***}$  lies so far below  $p_0^*$  (in Figure 4(b)) that free trade is the optimal policy. For rates of duty below  $T_S''$  increases in protection do not affect the monopolist's supply price to the home country - this remains at the low  $p^{***}$ . As a consequence the domestic price keeps rising, serving to restrict imports when their value at home (given by  $p$ ) exceeds their cost to the country (given by  $p^*$ ). Thus the first term in (6) is not operative, while the second term is negative and getting ever-larger in absolute value. For rates higher than  $T_S'$ , some terms-of-trade gains are achieved, but these are dominated by the adverse volume-of-trade effect.

---

<sup>9</sup>With reference to Figure 6(a), in the linear case the tariff rate  $T'_{opt}$  is optimal if  $p^{***}$  lies above  $p_0^*$ , but not by "too much". The relevant range is

$p^{***} \in [p_0^*, p_0^* + \frac{b - p_0^*}{3}]$ , where  $b$  represents the domestic price that would choke

off all demand (see footnote 3). Prices in the rest of the world,  $p^{***}$ , lying above this range correspond to initial real income at home similar to  $y''$  in

Figure 6(a), and the optimal tariff rate is twice the gap between  $p^{***}$  and  $p_0^*$ .

Situation double-prime (") in Figure 6(b) is less extreme, in that initial  $p^{**}$  is now assumed not to be as far below  $p_0^*$  as in case ('). As a consequence, for some tariff increases past rate  $T_S''$  (the minimum rate sufficient to allow the degree of segmentation most desired by the monopolist), the improvement in the terms of trade then forthcoming outweighs the smaller volume-of-trade welfare losses. However, free trade still remains the optimal policy.

Finally, situation (') shows a free-trade value of real income,  $y_0'$ , only slightly higher than it would be ( $y_0$ ) if the monopolist could naturally engage in price discrimination. Once again, the small economy free rides on the higher demand elasticities found in other countries. Even though for small rates of duty (up to  $T_S'$ ) the home country cannot improve its terms of trade - and suffers real income losses as increases in the domestic price cut back import demand - beyond this segmentation rate the terms of trade improve sufficiently so that (i) locally the terms of trade effect outweighs the negative volume-of-trade effect and (ii) positive protection (at  $T_{opt}'$ ) emerges as superior to a policy of free trade.

In all these cases the small country can improve its terms of trade, even if this might require substantial protection when it benefits initially from a lower supply price than the monopolist would charge should markets be naturally segmented. Whether it is optimal to push protection this far is another matter. A small open economy facing a monopoly supplier and initially penalized because the average demand elasticity abroad is lower than at home can always benefit by employing a tariff to provide the opportunity for the monopolist to discriminate in its favor. Even with roles reversed - when home

demand is relatively inelastic compared with world values - a policy of protection still has net value if the dissimilarity in demand elasticities is not too pronounced.

#### 4. The Metzler Paradox Case

In the "normal" case described in the preceding two sections, optimal pricing strategy for a monopolistic supplier to a fully segmented small open economy calls for a reduction in the supply price as a tariff is raised, but by less than the increase in the tariff rate so that domestic price rises. Equation (5) suggests the bounds within which the tariff-induced change in demand elasticity must lie in order to get this "normal" response. However, for sufficiently bowed-out demand curves the monopolist would find it optimal to react to a tariff with such a deep cut in supply price that domestic price actually falls. This is the analogue in the case of monopoly supply to the Metzler tariff paradox for competitive settings, although there are no home domestic producers who thus fail to receive protection with the duty. Equation (5) reveals that  $dp_m^*/dT$  will be less than minus one when:<sup>10</sup>

$$(8) \quad \frac{d\epsilon}{dT} > \frac{\epsilon(\epsilon - 1)}{(c^* + T)}$$

---

<sup>10</sup>The linear case, of course, does not satisfy this condition. It can easily be shown that for the case of linear demand  $d\epsilon/dT$  equals  $\frac{2b}{(b - c^* - T)^2}$ , while

$\frac{\epsilon(\epsilon - 1)}{(c^* + T)}$  equals  $\frac{2(b + c^* + T)}{(b - c^* - T)^2}$ . The monopolist lowers its supply price by half of any tariff.

Figure 7 illustrates the two possibilities in this case, depending on whether average demand elasticity in the rest of the world is lower than at home, case (a), or higher than at home, case (b). The horizontal line showing marginal (and average) costs for the monopolist has been drawn in order to emphasize that the Metzler-type phenomenon for the monopolist only has limited range. Profits would be zero on its sales to the small home country if its supply price were driven as low as  $c^*$ , and it can always do better than this if demand is never driven to the vanishing point by a high price.<sup>11</sup>

If home demand elasticity is relatively high, case (a), the monopolist takes full advantage of the tariff wall to lower supply price as much as the tariff wall allows - although the constraint imposed by the potential competition of agents in the rest of the world limits the fall in  $p_m^*$  compared to the fall shown along the curve for the case of full market segmentation. The home country is in a position somewhat similar to the ("") situation of Figure 6(a), with the optimal tariff shown by  $T_S$  in Figure 7(a).

The case portrayed in Figure 7(b) is more complex. At the initial free-trade situation the monopolist would prefer to discriminate and charge a higher price ( $p_0^*$ ) in the home country than it does to its other customers. For small tariffs, up to point A, the monopolist keeps to its supply price,  $p^{**}$ , but slightly higher tariffs now encourage the monopolist to discriminate in favor of the home country, and its supply price falls more rapidly than the tariff up to point B. For tariff rates up to A the domestic price rises, and subsequently falls from A to B. At point B home welfare must be greater than with free trade since the domestic price is the same and the terms of trade

---

<sup>11</sup>Of course in order to avoid a complete choking off of demand, price must enter a range in which condition (8) is violated. We assume (8) holds only for an initial range of tariffs.

have improved. Further tariff hikes up to  $T_S$  cause foreign supply price to keep falling, but only by as much as the tariff. Figure 8 shows the optimal tariff at rate  $T_S$  for this case, a rate actually exceeding the rate that would maximize real income if markets were completely segmented.

The situation shown in Figure 7(b) and Figure 8 is interesting in that for low rates of duty (or free trade) the monopolist is restrained by its activities in the rest of the world from charging as high a supply price as it would like in the home market, but eventually this position gets reversed so that with tariff rates between  $T_B$  and  $T_S$  the monopolist is restrained from charging as low a price as it would like. The cause for restraint is different in these two situations. For low rates of duty the monopolist keeps  $p^*$  lower (than along the fully-segmented curve) because it does not want its customers in the rest of the world to undercut it in the small open economy, whereas for rates between  $T_B$  and  $T_S$  it sets its price at the low end of the allowable tariff range but no lower in order to forestall home country residents from re-selling in world markets. Unlike the situation shown in Figure 4(b) for the "normal" case, the home market is not effectively segmented for all tariff rates higher than  $T_A$ ; rates higher than  $T_B$  (and lower than  $T_S$ ) leave the monopolist charging higher supply prices than it would select with full segmentation.

##### 5. The Case for Import Subsidies

When importables are supplied by a foreign monopolist, Brander and Spencer (1984) and, earlier, De Meza (1979), have suggested that an import

subsidy may be more appropriate than a tariff. The reasoning supporting this view has a firm foundation when the home market is completely segmented and the demand curve is significantly bowed in towards the origin. Indeed equation (5) reveals the necessary requirement: the expression for  $dp_m^*/dT$  must be positive, and this in turn requires that

$$(9) \quad \frac{d\epsilon}{dT} < \frac{(\epsilon - 1)}{(c^* + T)}.$$

Thus, as already noted, a constant elasticity demand curve satisfies this requirement; a specific tariff would worsen the terms of trade (although, as discussed in footnote 4, an ad valorem tariff leaves supply price unaltered). In terms of Figure 1, the MM curve would be negatively sloped and, in Figure 4, the  $p_m^*$  curve emanating from  $p_o^*$  would have positive slope. If a tariff worsens the terms of trade, so goes the argument, an import subsidy would encourage the monopolist to lower its supply price.

When a small open economy shares an integrated world market with other countries, this argument needs to be qualified. The first point to make is that a pure subsidy on importables levied by the home country is an act of folly unless it is accompanied by an export tax or other barrier preventing agents at home from re-exporting to the rest of the world. If no such barriers are placed, the rest of the world would use the small open economy as the source through which to channel all imports from the monopolist. The home country's treasury would soon be emptied.

Suppose, instead, that an import subsidy is accompanied by an equivalent export tax. This, then, preserves the benefits of the subsidy to home consumers. However, a tariff accomplishes something which a subsidy does not:

it allows a degree of market segmentation. Let the home country levy a specific import subsidy at rate  $\underline{S}$ . The price to home consumers importing from the monopolist would be  $p^* - S$ . In order that third parties abroad not re-export to the home country at a profit it is necessary that  $p^{**} - S$  not fall short of this value, i.e., that  $p^{**} \geq p^*$ , since we assume the subsidy is non-discriminatory. But home agents can re-export the commodity to consumers in the rest of the world at price  $p^*$ , so that to prevent successful arbitrage in this direction,  $p^*$  must be  $\geq p^{**}$ . The upshot: the monopolist's supply price to the home country,  $p^*$ , must equal its price to the rest of the world,  $p^{**}$ . Tariffs lead to partial or complete market segmentation whereas import subsidies, even when matched by equivalent export taxes, do not.

Assume that the demand curve exhibits a sufficiently bowed-in shape to satisfy restriction (9), and that a tax on re-exports is imposed at a level matching the import subsidy. Three cases are shown in Figure 9, and in all of them we illustrate a rising curve passing through  $p_0^*$  to reflect our assumption that in a fully segmented market the country could benefit from improved terms of trade with a subsidy. If a subsidy is levied (and a matching export tax installed) when the country is part of an integrated world market, the monopolist has no option but to keep its supply price at  $p^{**}$  in all three cases. Thus a subsidy does not improve a country's terms of trade. Although it does not harm the country's terms of trade either, it imposes a welfare burden since, in this case,

$$(10) \quad \frac{dy}{dS} = -S \frac{dD}{dS},$$

and the lower domestic price which a subsidy allows encourages demand when,



for any finite level of the subsidy, the commodity is worth less at home ( $p$ ) than it costs to obtain from the monopolist ( $p^*$ ).

Turn, now, to the possible use of a tariff. In the benchmark case (c) a tariff does no good. The monopolist charges a supply price at the upper end of the tariff wedge, keeping  $p^*$  equal to  $p^{**}$  (equal to  $p_0^*$ ). In a fully segmented market the tariff would worsen the terms of trade, but the existence of an outside world trading at  $p^{**}$  prevents this. Similarly, in case (b) in which the outside world has a higher elasticity of demand than at home a tariff does not alter the terms of trade. In both these cases free trade is optimal. The situation in which the home country has a more elastic demand than is found, on average, in the rest of the world (case (a)) is once again one in which a tariff by the small open economy can be used to advantage. From free trade to tariff level  $T_{opt}$ , the tariff improves the terms of trade by the full amount of the tariff despite elasticity condition (9). It is clear that this is the optimal level since increases in the tariff rate beyond this level worsen the terms of trade.

These remarks suggest that the case for an import subsidy is rather weak when the home country faces a monopolistic supplier who services other countries. However, an import subsidy coupled with a tax on re-exports which is levied at a higher rate than the subsidy provides precisely the kind of market segmentation which may be beneficial to the small open economy. To expedite the argument, let us suppose the country levies an absolute ban on re-export of the monopolist's product, thus obviating the monopolist's concern that an agent at home whose purchases are heavily subsidized could turn around and threaten the monopolist's market in the rest of the world.

Reconsider the possibilities shown in Figure 9 when there is no longer any limitation on the down-side to the price,  $p^*$ , the monopolist would be encouraged to charge the home country if home consumers are subsidized at rate  $S$ . Both in the benchmark case, (c), and in the case (a) in which the monopolist's price in the rest of the world ( $p^{**}$ ) exceeds the price it would charge in a segmented home market, some level of import subsidy is now appropriate.<sup>12</sup> The relationship between home real income and import tariff rates shown in Figure 5 no longer suffices if, as now assumed for segmented markets, a small tariff worsens the terms of trade. Instead, the real income curve (not drawn) reaches a peak at some positive rate of subsidy. A sufficiently high re-export tax allows such a peak to be attained. The situation shown in Figure 9(b) is more problematic in that a finite subsidy is required before any terms-of-trade improvement can be brought about, so that free trade may be preferred to any subsidy level, even a level high enough to lower the monopolist's supply price below  $p^{**}$ .<sup>13</sup>

---

<sup>12</sup>In case (a), a re-export tax at rate  $(p^{**} - p_0^*)$  would suffice to permit the monopolist to charge segmented, free-trade price  $p_0^*$ . However, an import subsidy coupled with an even higher level of re-export tax can be an even better combination for the home country.

<sup>13</sup>The situation is somewhat analogous to Figure 6(b) if the tariff rate,  $T$ , in that diagram is replaced by the subsidy rate  $S$ . For example, if  $y_0''$  (or  $y_0'''$ ) is the free-trade real-income level, it is preferred to the level of real income attained at the peak of the segmented curve. The status [in Figure 9(b)] of being a free-rider on the world's high demand elasticity is not worth jeopardizing by segmenting the market and paying the subsidies required to engineer a terms-of-trade improvement.

## 6. Foreign Tariffs

Tariffs tend to segment markets, whether they are levied by the small open economy or by countries in the rest of the world. In this section we ask how a tariff, set at a uniform rate by all countries in the rest of the world, can affect the monopolist's pricing policy in the small open economy.

Although a tariff set by the small open economy cannot affect  $p^{**}$ , the rest of the world is large enough to affect its own terms of trade. Here we assume results are "normal" in that the rest of the world succeeds in lowering the monopolist's supply price from  $p_0^{**}$  to  $(p^{**})'$  but by less than the tariff so that price to consumers in the rest of the world increases. That is,

$$(11) \quad (p^{**})' < p_0^{**} < (p^{**})' + T^{**}.$$

where  $T^{**}$  indicates the foreign tariff. The supply price charged to the home country,  $p^*$ , can now lie anywhere in this range. It cannot lie below  $(p^{**})'$ , because then agents in the free-trade home country could undercut the monopolist in the rest of the world. And if  $p^*$  were set higher than the domestic price abroad, foreign agents could undersell the monopolist in the home market.

Figure 10 illustrates the free-trade profit function of the monopolist in the small open economy. In case (a) the original world price,  $p_0^{**}$ , lies above the price the monopolist would charge at home in segmented markets,  $p_0^*$ , indicating a relatively high value for home demand elasticity. This comparison is reversed in case (b). The foreign tariff,  $T^{**}$ , has, we assumed, lowered the monopolist's supply price abroad to  $(p^{**})'$  and raised foreign

domestic price to  $(p^{**})' + T^{**}$ . In case (a) the foreign monopolist now can increase its profits in the home market by dropping its supply price to the new lower supply price abroad (the move from A to B along the foreign profit function). This is of benefit to the home country. In case (b), by contrast, the monopolist moves from A' to B', charging a higher price to the home country. The home country is hurt even though the foreign tariff has improved the terms of trade for all the rest of the world. In this sense it cannot "free-ride" on the rest of the world's tariff, as it would in the competitive case. The monopolist takes advantage of the tariff wall set up in the rest of the world to charge a higher price to the home country, confident that this price cannot be undercut by agents in the rest of the world.

In both these cases the foreign tariff has introduced an element of partial segmentation in world markets. The monopolist can take advantage of this situation to increase its profits at home by moving its supply price closer to the level that would yield maximum profits in a fully segmented world.

## 7. Conclusion

In a world market characterized by perfectly competitive behavior, a small open economy cannot employ commercial policy instruments in order to improve its terms of trade. This conclusion provides the major argument for a free-trade policy for the small country. By contrast, if the small open economy faces a monopolistic supplier abroad for its importables, it almost always can set a tariff that improves its terms of trade. The reason is not

that the small country can affect the monopolist's pricing decisions in the world market. Instead, the tariff provides a degree of market segmentation so that the monopolist may find it possible and profitable to discriminate between the prices it charges in the small open economy and the rest of the world. The extent to which the monopolist desires to charge a different price in the home market depends on the relationship between import demand elasticity at home and its average value in other consuming countries. Thus a small open economy with a higher than average demand elasticity suffers from being in a free-trade integrated world market in which the price it pays for imports exceeds the price the monopolist would charge if it could engage in price discrimination. A tariff provides the means to allow the monopolist to charge a lower price to the small open economy.

Our analysis reveals that although a sufficiently high rate of protection almost always improves the terms of trade, it is not always in the small open economy's interests to pursue a policy of protection. This is especially the case if the rest of the world's demand elasticity is higher than that at home, so that in an integrated free-trade market the small open economy is a free-rider in the sense of paying a lower price than it would if the monopolistic supplier could segment markets.

Tariffs levied in the rest of the world also provide a degree of market segmentation in the home market. Although a protective stance by other countries may lower the monopolist's supply price to them, it will also lower it for the small open economy only if the small country has a higher demand elasticity so that it has paid a penalty for being part of an integrated world market.

If markets are fully segmented, an import subsidy might improve the terms of trade. However, in an integrated world the small open economy can reap the advantages of an import subsidy only if it imposes as well a tax to discourage re-exports. Indeed, a degree of market segmentation would be provided to the monopolist only if the re-export tax is levied at a higher rate than the subsidy. Once again it is net protection that is required to encourage price discrimination on the part of the monopolist.

Crucial in our analysis is the concern of the monopolist over potential entry into one or more of its markets. Existing literature analyses the possibility of other producers entering the market, e.g., domestic producers in the case of Brander and Spencer (1981). In this paper the threat of entry comes not from producers, but from consumers in other markets. It is the integration of markets worldwide which restricts the freedom of the monopolist to charge a different price in each national market. And it is the sovereign power of a country to isolate transactions within its own borders by exercise of commercial policy which expands the range of choice for the monopolist. As we have argued, this power can often be harnessed to national advantage even if the country forms only a small part of the monopolist's world market.

## References

- Brander, James A. and Barbara J. Spencer, 1981. "Tariffs and the Extraction of Foreign Monopoly Rents Under Potential Entry." Canadian Journal of Economics, 16, pp. 289-299.
- Brander, James A. and Barbara J. Spencer, 1984. "Trade Warfare: Tariffs and Cartels," Journal of International Economics, 16, pp. 227-242.
- Caves, Richard E. and Ronald W. Jones, 1985, World Trade and Payments, Fourth Edition.
- DeMeza, David, 1979, "Commercial Policy Towards Multinational Monopolies - Reservations on Katrak," Oxford Economic Papers, 31, pp. 334-337.
- Horst, Thomas, 1971, "The Theory of the Multinational Firm; Optimal Behavior Under Different Tariff and Tax Rates," Journal of Political Economy, 79, pp. 1059-1072.
- Jones, Ronald W., 1987, "Trade Taxes and Subsidies with Imperfect Competition," Economic Letters, 23, pp 375-379.
- Katrak, Homi, 1977, "Multinational Monopolies and Commercial Policy," Oxford Economic Papers, 29, pp. 283-291.
- Krugman, Paul, 1986, "New Trade Theory and the Less Developed Countries," a paper prepared for "Debt, Stabilization and Development," a conference in memory of Carlos Diaz-Alejandro, Helsinki.

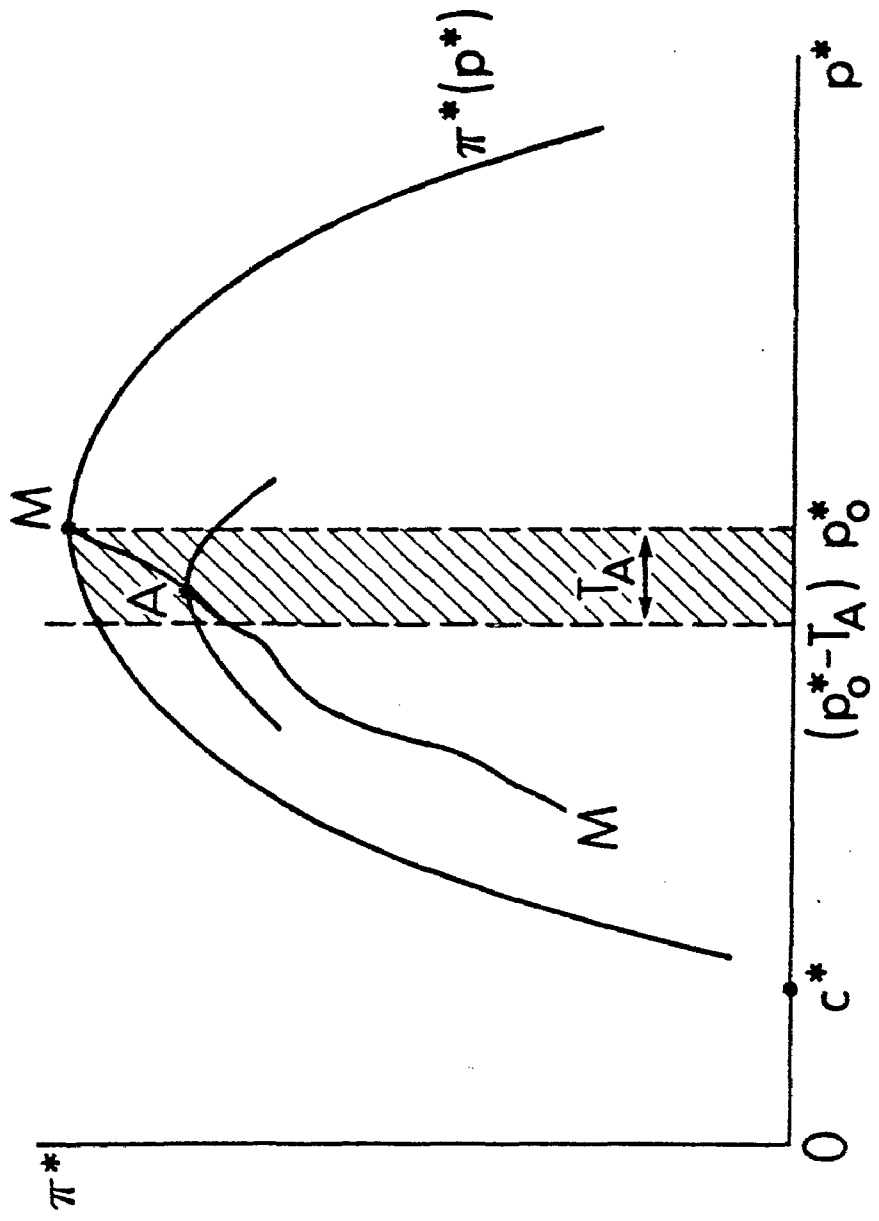

Figure 1



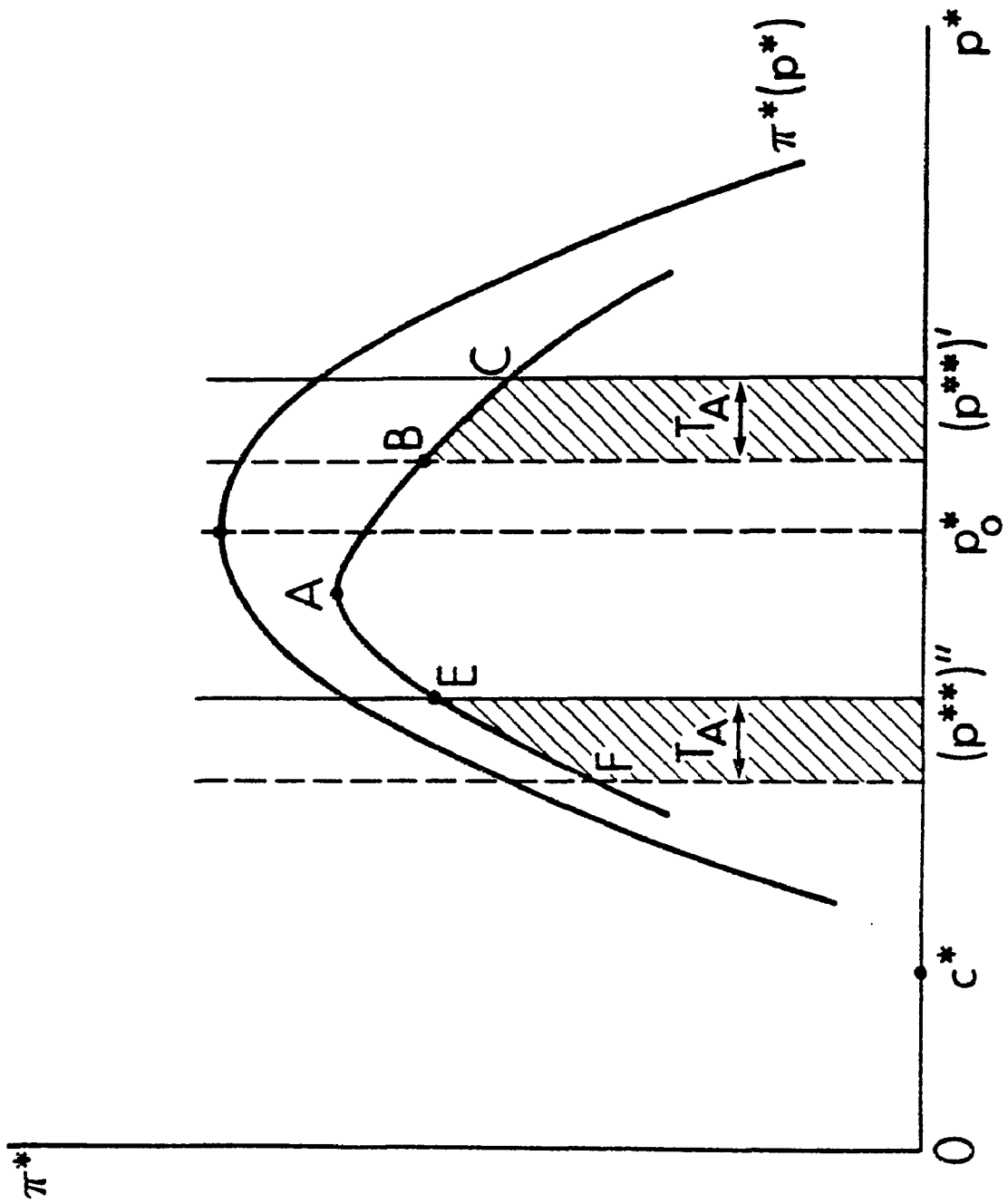

Figure 2

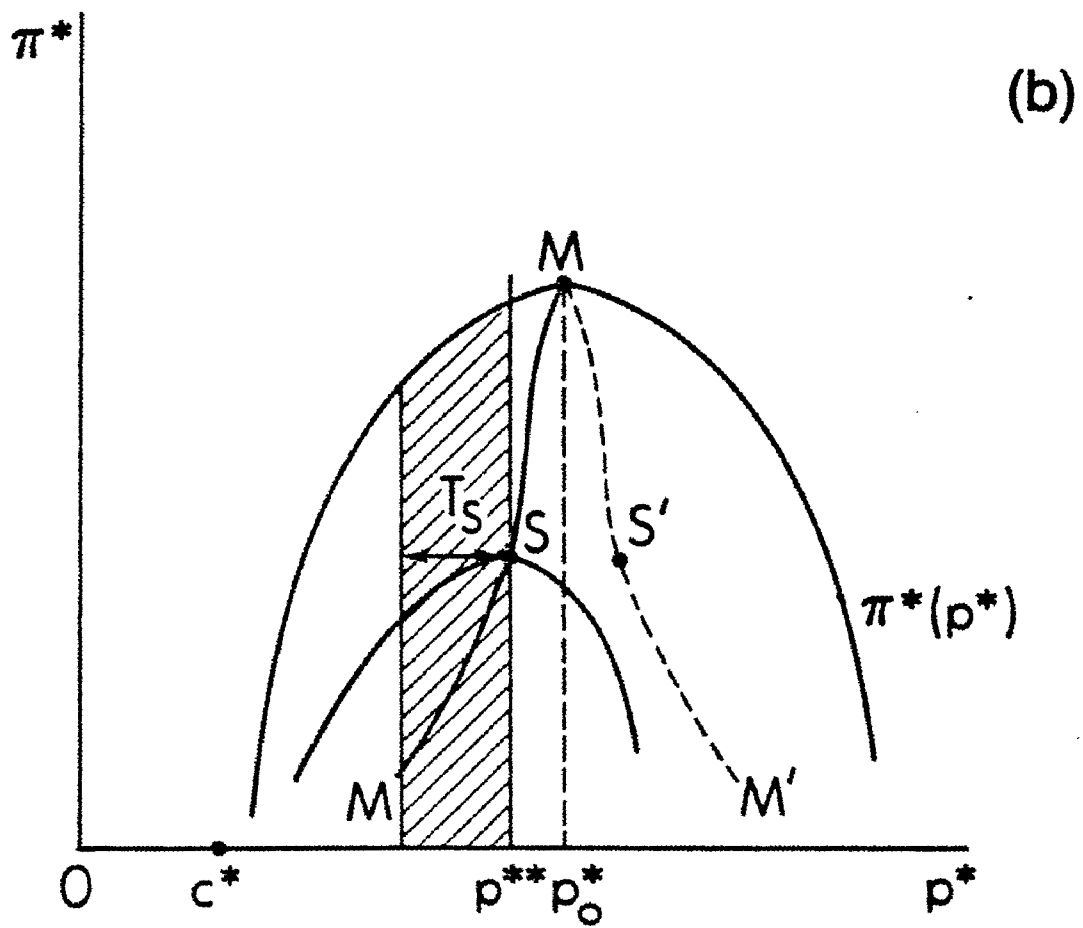
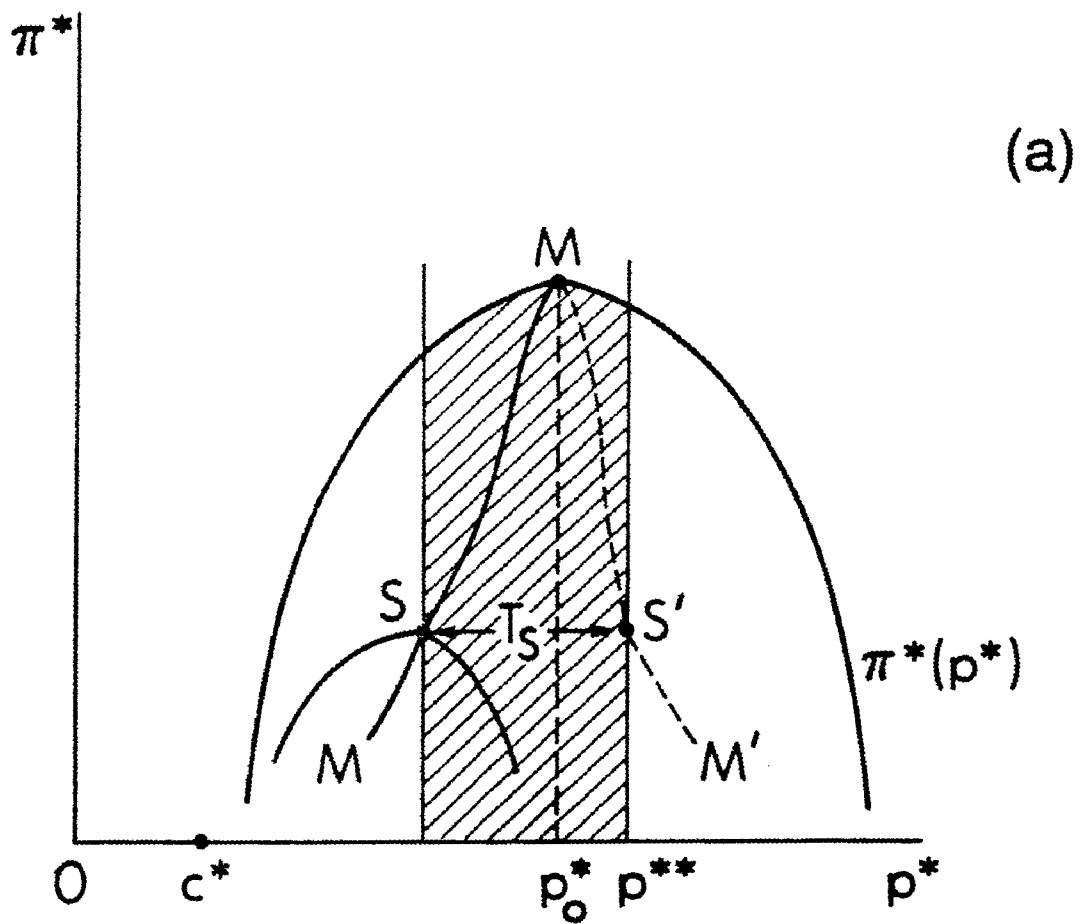

Figure 3

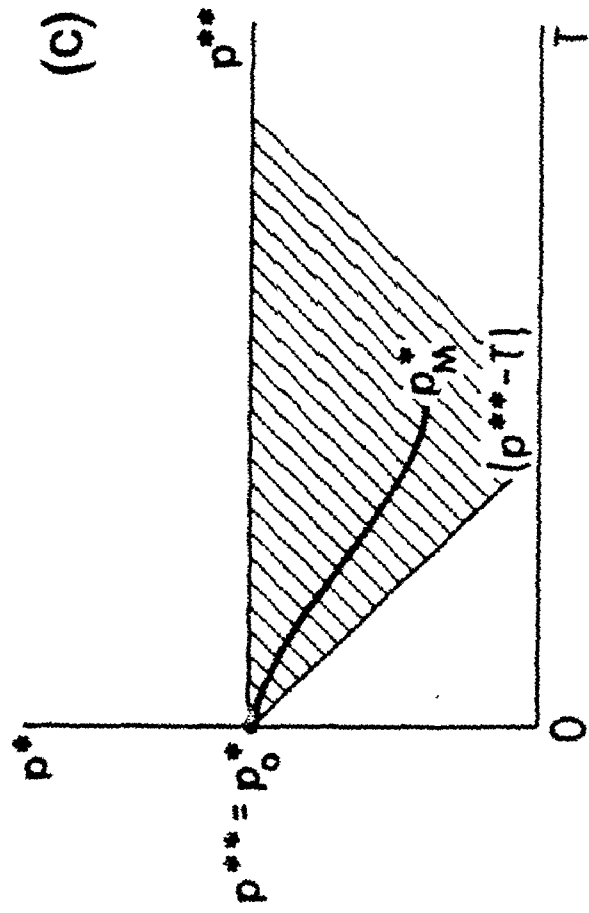
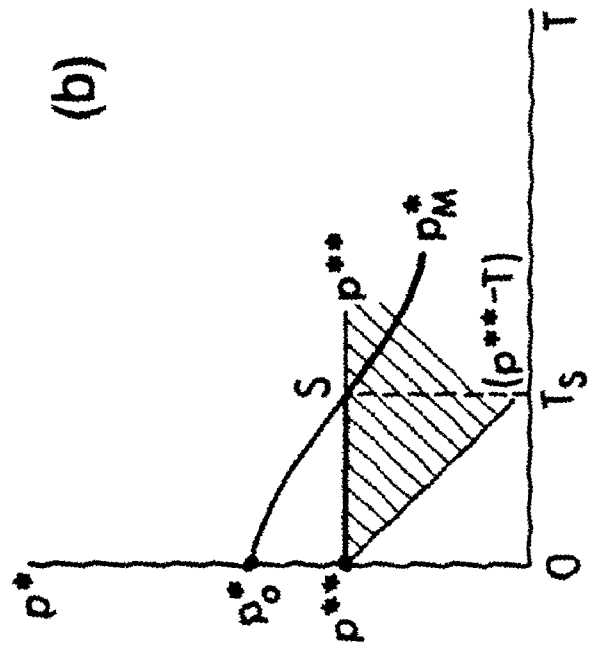
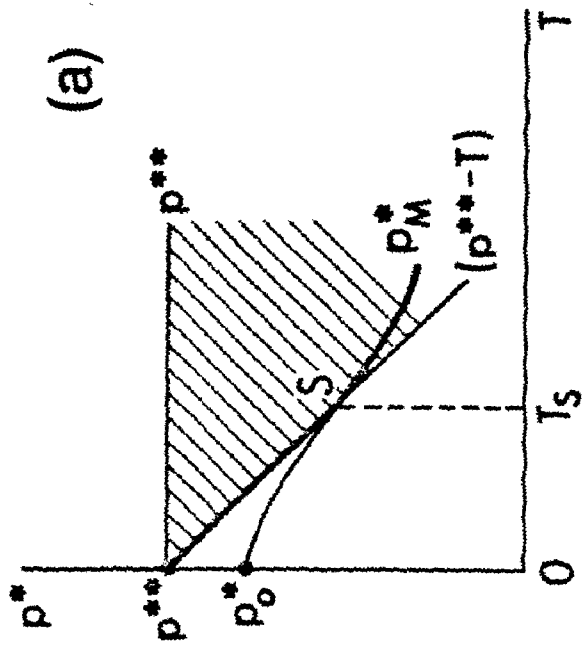

Figure 4

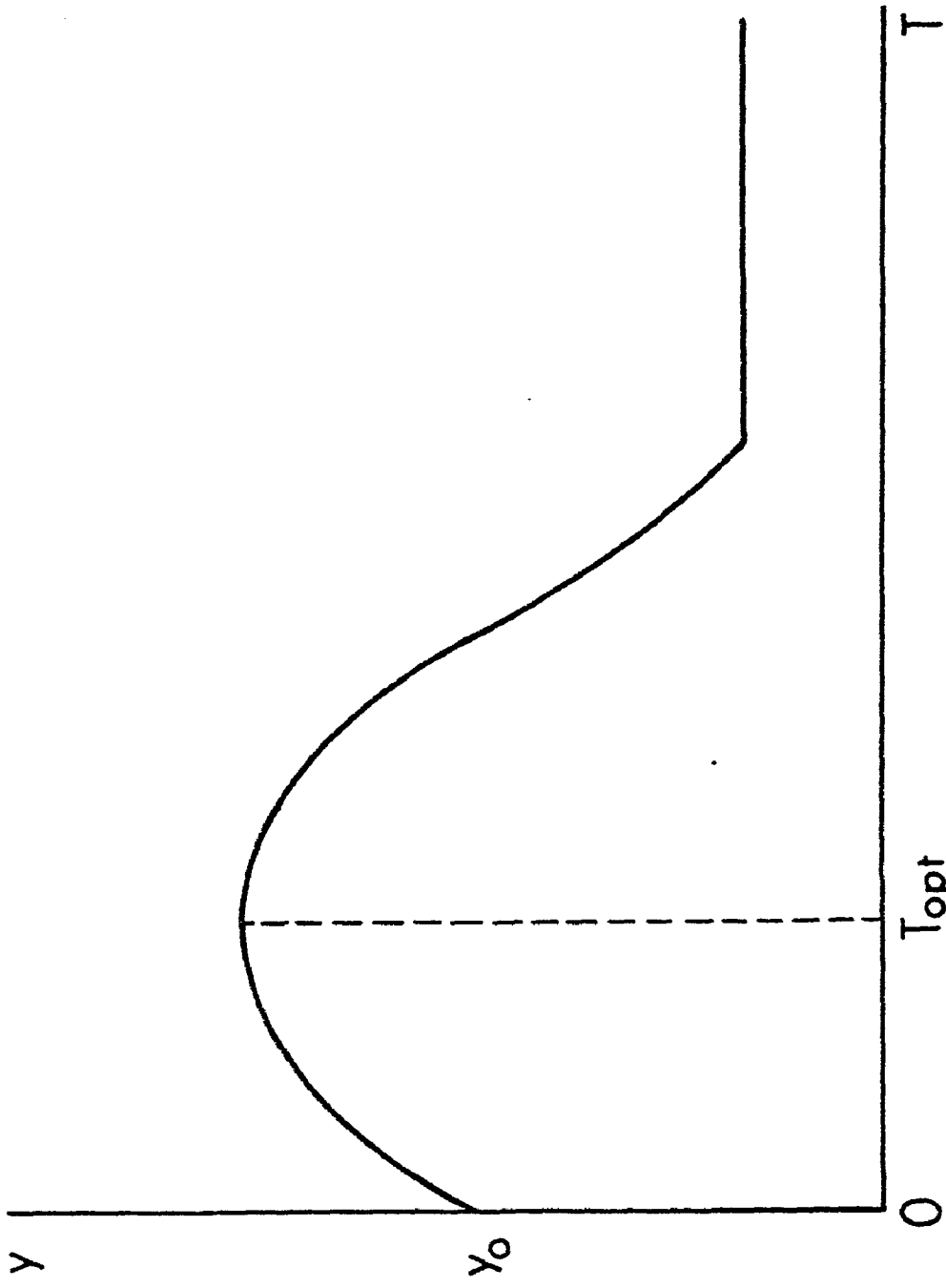

Figure 5

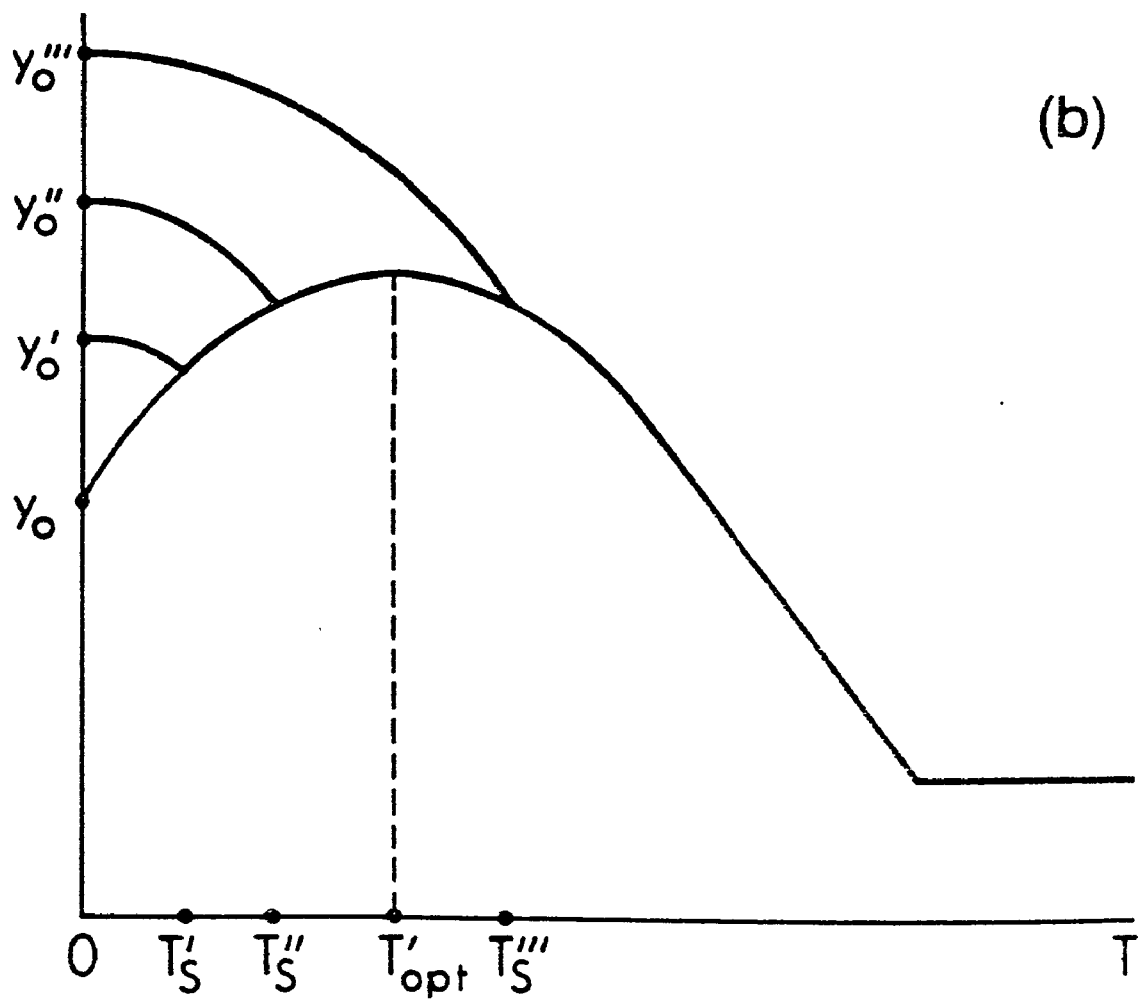
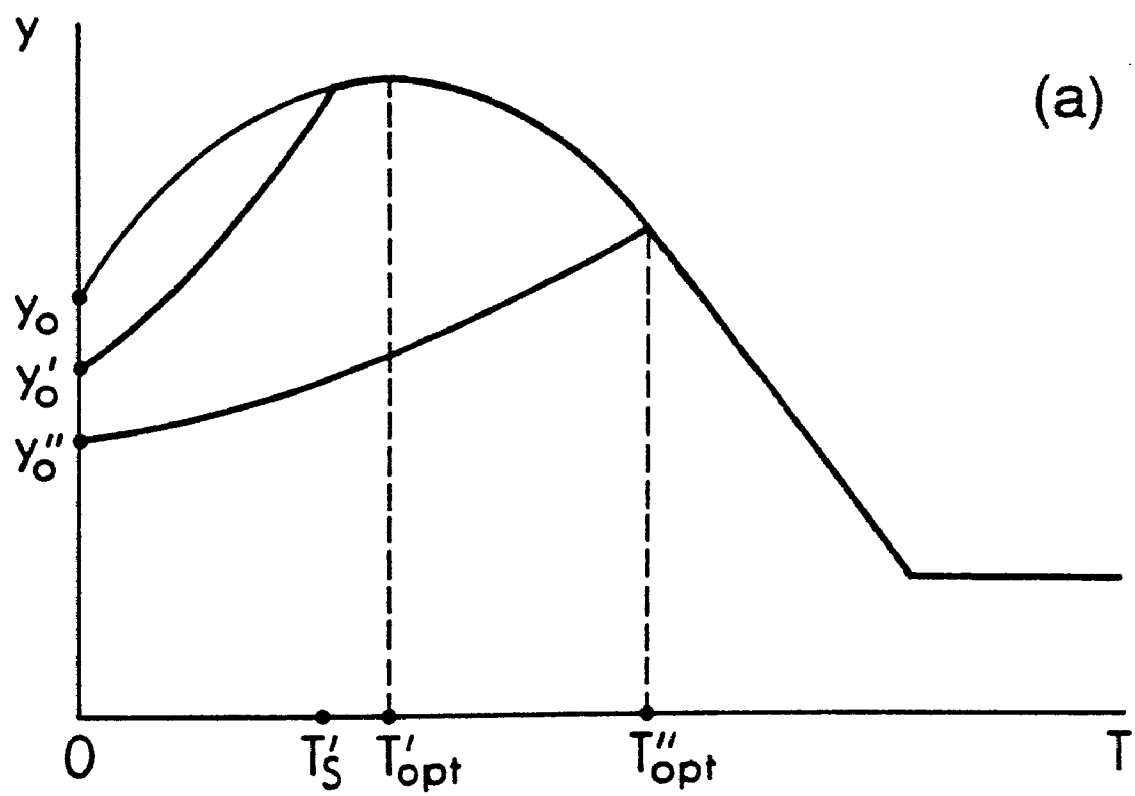

Figure 6

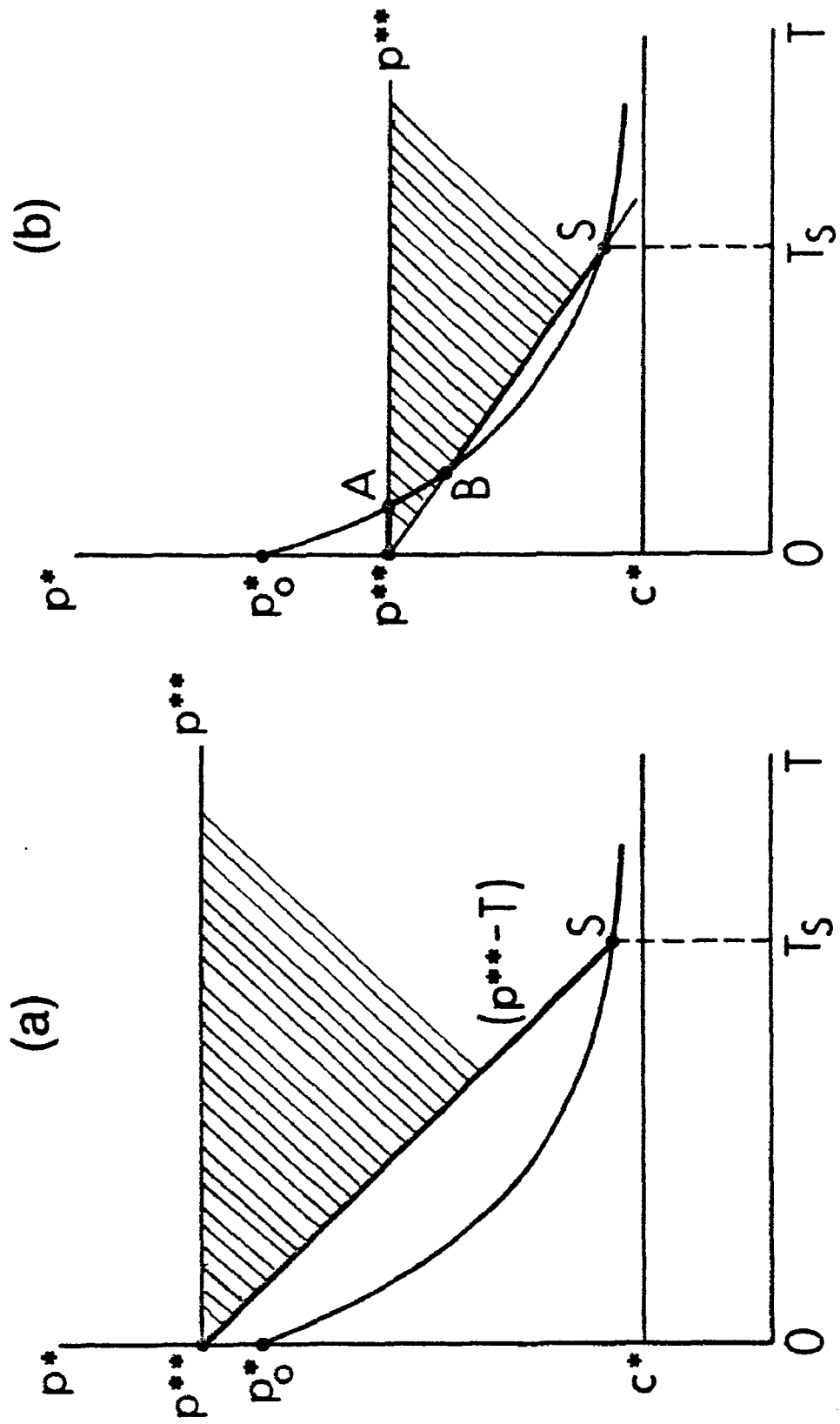

Figure 7

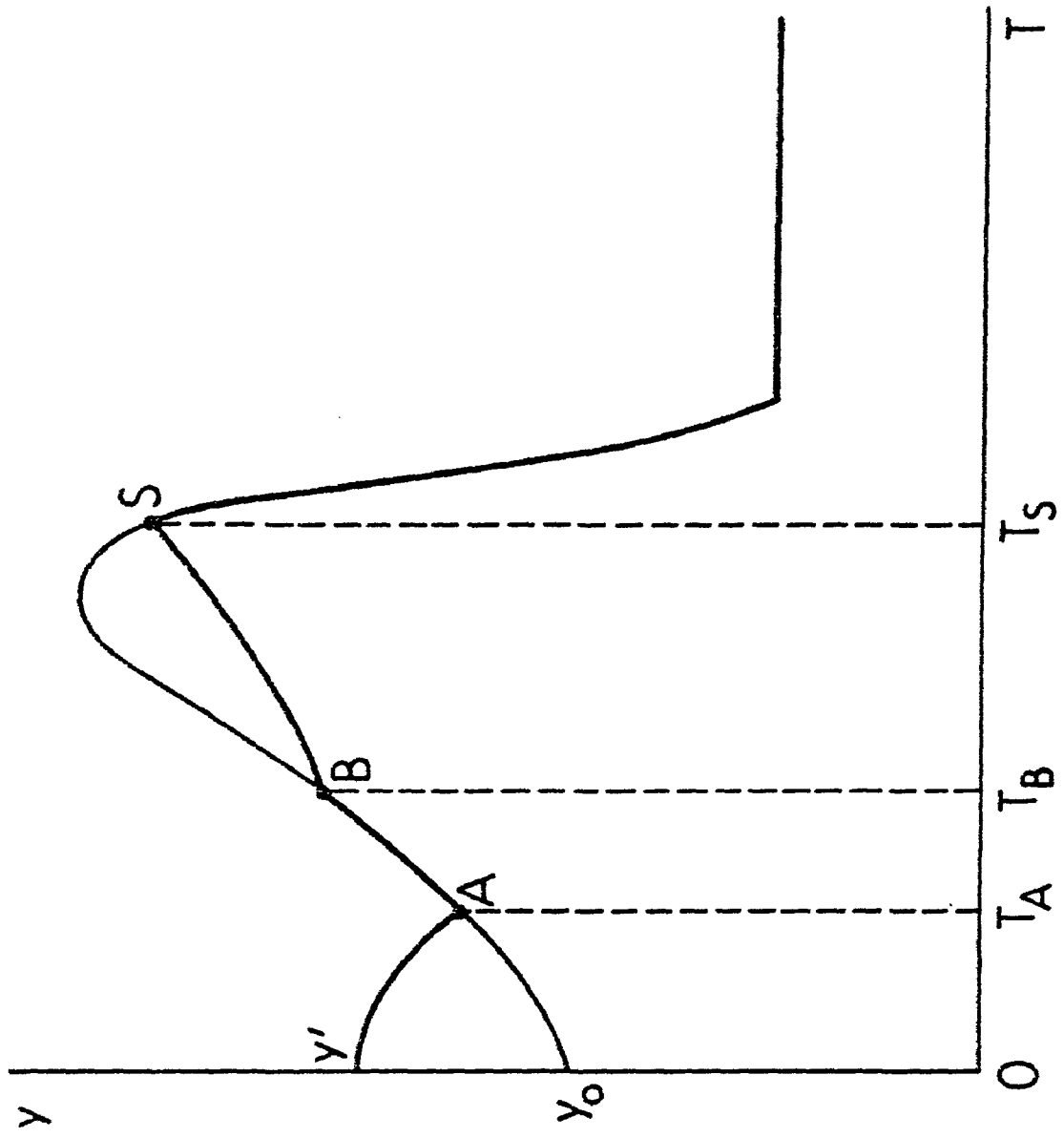
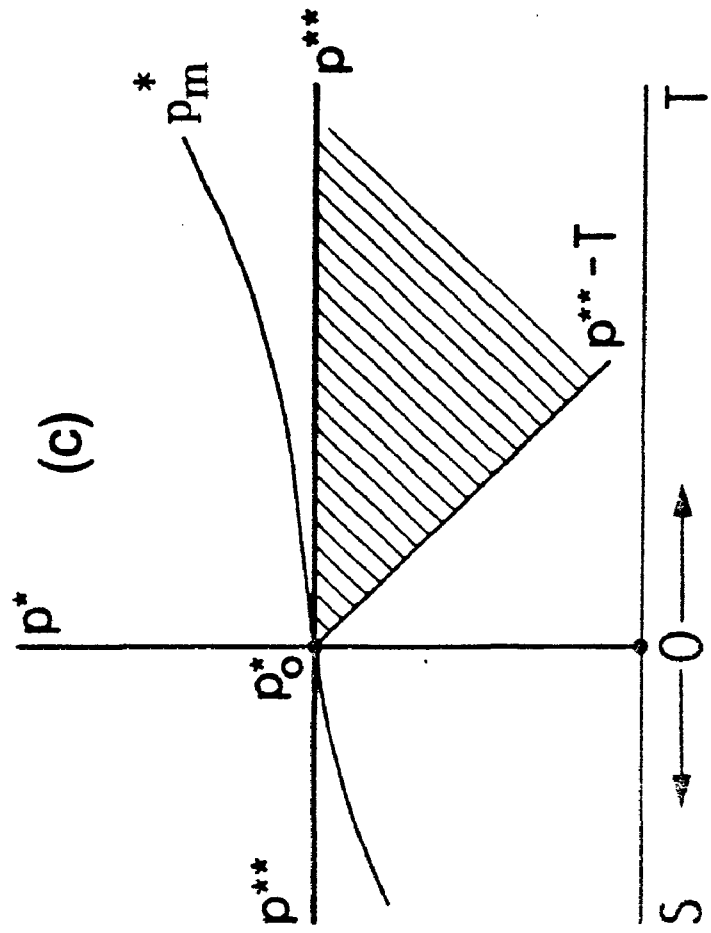
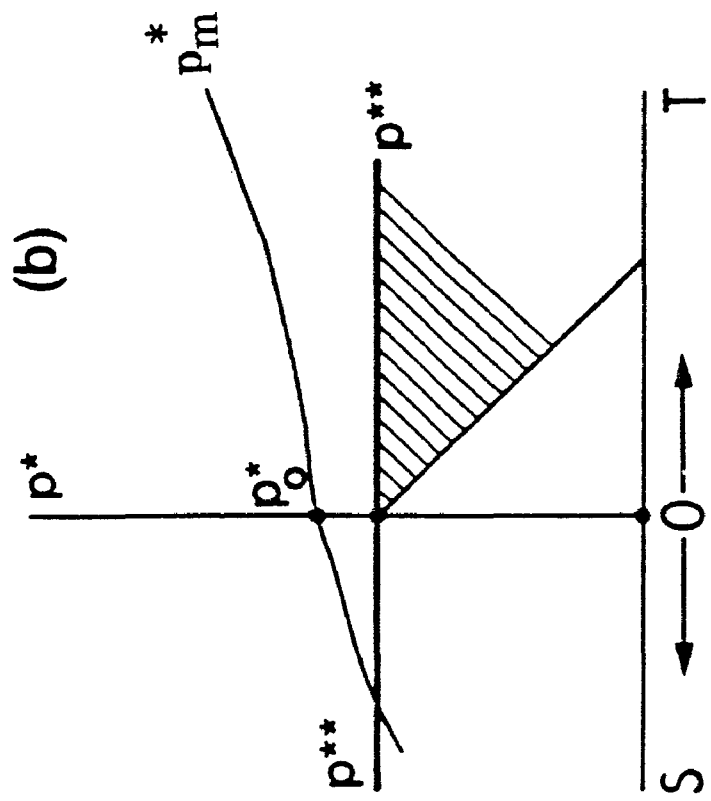
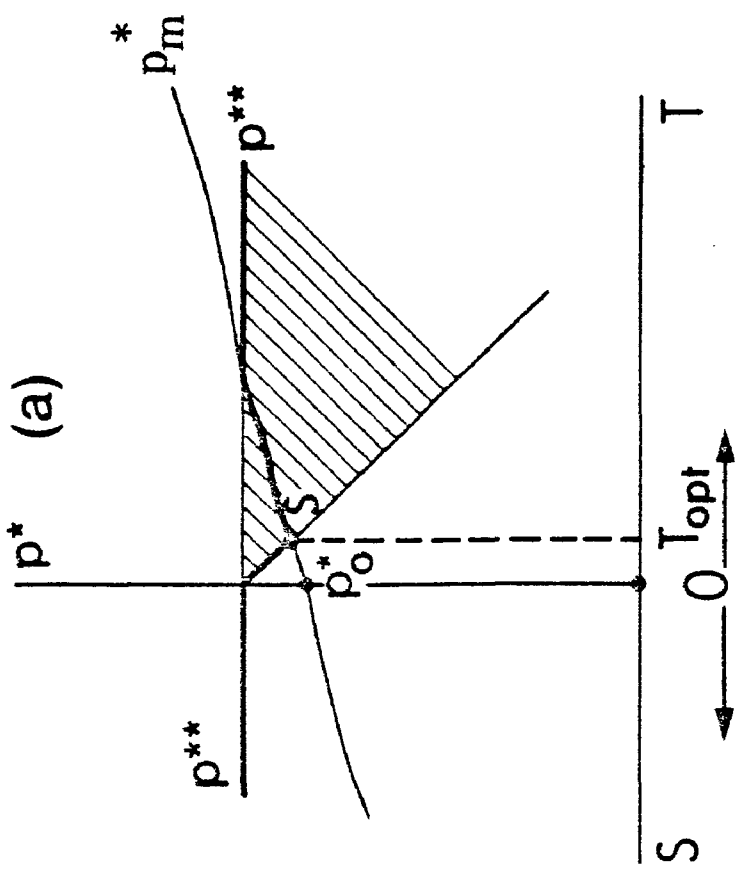

Figure 8





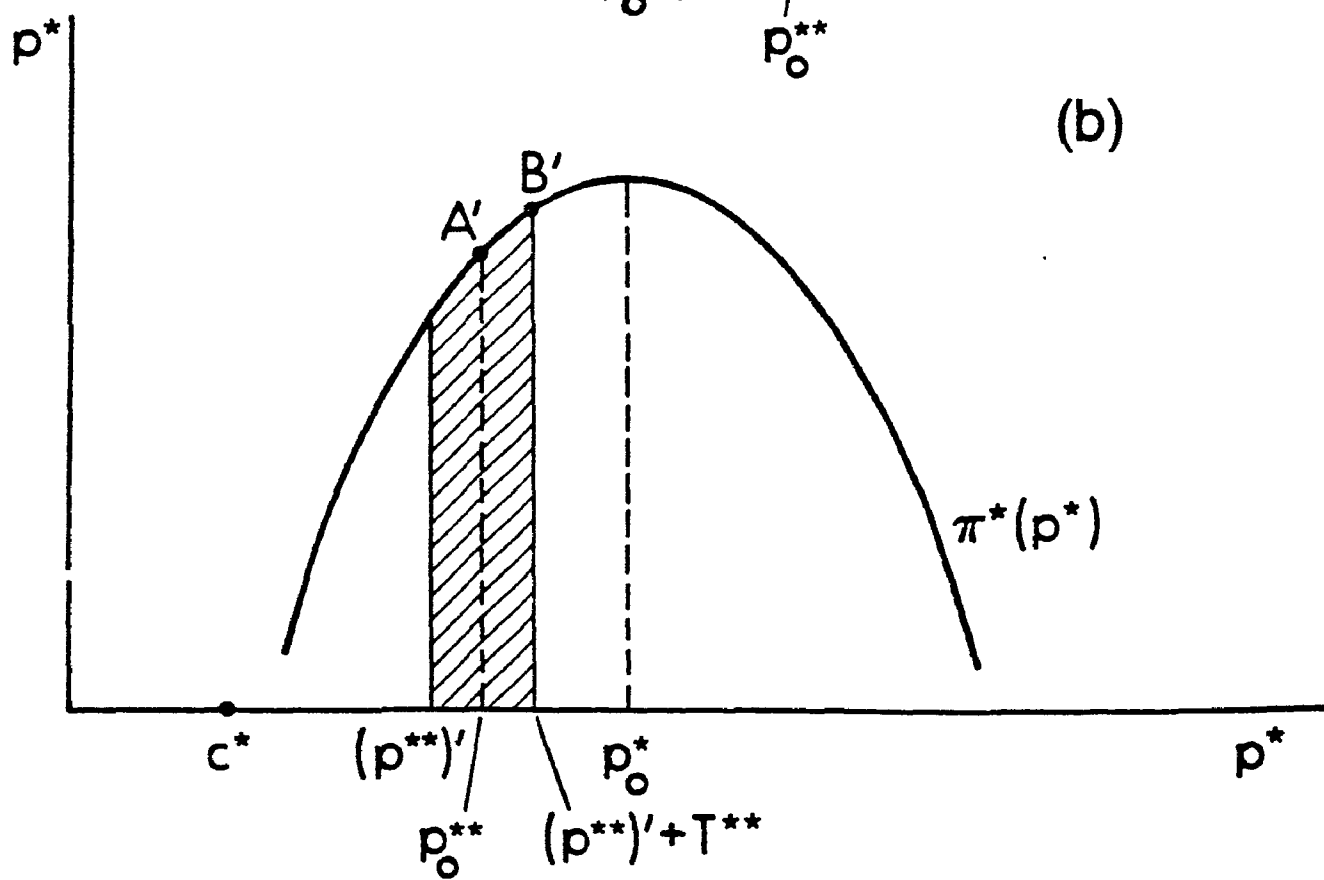
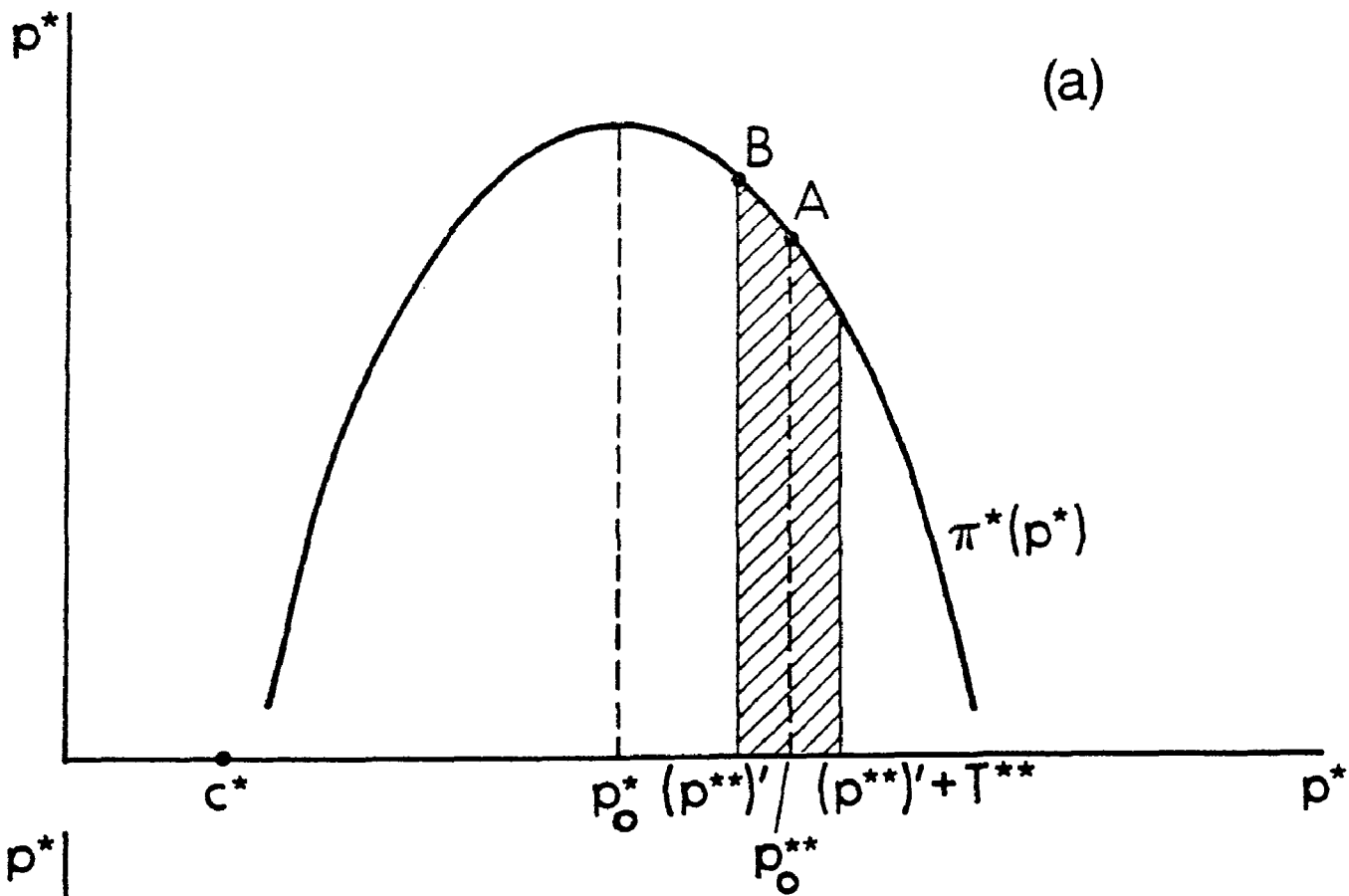

Figure 10